

NATIONAL BUREAU OF STANDARDS REPORT

NBS PROJECT

2321121

January 24, 1973

NBS REPORT

10 987

ON THE MEASUREMENT OF THREAD MEASURING WIRES

by

B. Nelson Norden



U.S. DEPARTMENT OF COMMERCE
NATIONAL BUREAU OF STANDARDS

NATIONAL BUREAU OF STANDARDS

The National Bureau of Standards¹ was established by an act of Congress March 3, 1901. The Bureau's overall goal is to strengthen and advance the Nation's science and technology and facilitate their effective application for public benefit. To this end, the Bureau conducts research and provides: (1) a basis for the Nation's physical measurement system, (2) scientific and technological services for industry and government, (3) a technical basis for equity in trade, and (4) technical services to promote public safety. The Bureau consists of the Institute for Basic Standards, the Institute for Materials Research, the Institute for Applied Technology, the Center for Computer Sciences and Technology, and the Office for Information Programs.

THE INSTITUTE FOR BASIC STANDARDS provides the central basis within the United States of a complete and consistent system of physical measurement; coordinates that system with measurement systems of other nations; and furnishes essential services leading to accurate and uniform physical measurements throughout the Nation's scientific community, industry, and commerce. The Institute consists of a Center for Radiation Research, an Office of Measurement Services and the following divisions:

Applied Mathematics—Electricity—Heat—Mechanics—Optical Physics—Linac Radiation²—Nuclear Radiation²—Applied Radiation²—Quantum Electronics³—Electromagnetics³—Time and Frequency³—Laboratory Astrophysics³—Cryogenics³.

THE INSTITUTE FOR MATERIALS RESEARCH conducts materials research leading to improved methods of measurement, standards, and data on the properties of well-characterized materials needed by industry, commerce, educational institutions, and Government; provides advisory and research services to other Government agencies; and develops, produces, and distributes standard reference materials. The Institute consists of the Office of Standard Reference Materials and the following divisions:

Analytical Chemistry—Polymers—Metallurgy—Inorganic Materials—Reactor Radiation—Physical Chemistry.

THE INSTITUTE FOR APPLIED TECHNOLOGY provides technical services to promote the use of available technology and to facilitate technological innovation in industry and Government; cooperates with public and private organizations leading to the development of technological standards (including mandatory safety standards), codes and methods of test; and provides technical advice and services to Government agencies upon request. The Institute also monitors NBS engineering standards activities and provides liaison between NBS and national and international engineering standards bodies. The Institute consists of a Center for Building Technology and the following divisions and offices:

Engineering Standards Services—Weights and Measures—Invention and Innovation—Product Evaluation Technology—Electronic Technology—Technical Analysis—Measurement Engineering—Fire Technology—Housing Technology⁴—Federal Building Technology⁴—Building Standards and Codes Services⁴—Building Environment⁴—Structures, Materials and Life Safety⁴—Technical Evaluation and Application⁴.

THE CENTER FOR COMPUTER SCIENCES AND TECHNOLOGY conducts research and provides technical services designed to aid Government agencies in improving cost effectiveness in the conduct of their programs through the selection, acquisition, and effective utilization of automatic data processing equipment; and serves as the principal focus within the executive branch for the development of Federal standards for automatic data processing equipment, techniques, and computer languages. The Center consists of the following offices and divisions:

Information Processing Standards—Computer Information—Computer Services—Systems Development—Information Processing Technology.

THE OFFICE FOR INFORMATION PROGRAMS promotes optimum dissemination and accessibility of scientific information generated within NBS and other agencies of the Federal Government; promotes the development of the National Standard Reference Data System and a system of information analysis centers dealing with the broader aspects of the National Measurement System; provides appropriate services to ensure that the NBS staff has optimum accessibility to the scientific information of the world, and directs the public information activities of the Bureau. The Office consists of the following organizational units:

Office of Standard Reference Data—Office of Technical Information and Publications—Library—Office of International Relations.

¹ Headquarters and Laboratories at Gaithersburg, Maryland, unless otherwise noted; mailing address Washington, D.C. 20234.

² Part of the Center for Radiation Research.

³ Located at Boulder, Colorado 80302.

⁴ Part of the Center for Building Technology.

NATIONAL BUREAU OF STANDARDS REPORT

NBS PROJECT

2321121

January 24, 1973

NBS REPORT

10 987

ON THE MEASUREMENT OF THREAD MEASURING WIRES

by

B. Nelson Norden



U.S. DEPARTMENT OF COMMERCE
NATIONAL BUREAU OF STANDARDS

On the Measurement of Thread Measuring Wires

Foreword

In view of the future NBS three-dimensional facility, we have sought to review some of our current calibration procedures and, where appropriate, evaluate the feasibility of transfer to the new facility. In cases where it is not feasible to transfer, to upgrade our former procedures. This report is the first in a series which will be referred to as calibration procedure reports. In many cases the facts which will be presented in this series of documents are widely known but their collection into concise reports will, it is hoped, serve the purposes of:

- (1) acquainting other individuals in our section with the nomenclature of calibrations now being performed,
- (2) serving as a focal point for discussion as to how we may either transfer or upgrade procedures,
- (3) permitting us to standardize many of our procedures so we may analyze our mechanical measurements to view the relative indexes of precision and, where appropriate, define new ones.

Some procedures are always in a state of flux, therefore, only current calibration procedures will be emphasized.

During recent months, with the installation of a computer time-sharing facility, we have adopted more automated procedures of data processing wherever possible. The advantages of this type of operation

are self-evident. The methods of accomplishing this processing are varied, but a few appropriate ways will be discussed at some later date.

In the specific case of the calibration of reference thread measuring wires, a version of the measurement assurance program has been adopted to assist in achieving the stated goals.

Introduction

To measure accurately the pitch diameter (PD)* of a threaded plug, a standard uniform practice has been established which utilizes small hardened steel cylinders or thread wires of correct size being placed in the thread grooves. In the optimum situation, the wires should touch the flanks of the thread at the midslope (Fig. 1). Assuming the thread is perfect, this size, called the "best size wire" for any given pitch, is given by the equation:

$$D = \frac{P}{2} \text{Sec } \alpha$$

where

D is diameter of wire

P is pitch

α is half angle of the thread.

The measured value for the pitch diameter depends upon the accuracy of the measuring device, the contact force, the thread form, and the diameter of the thread wires. It is necessary to know the value of the thread wire diameter to a high degree of accuracy since any error in the wire diameter is multiplied.

Borrowing nomenclature from the Simpsonian dialectic**, the concept,

*PD is the diameter of an imaginary cylinder whose surface passes through the thread at such points as to define equal areas in thread groove and thread ridge. This definition applies only to a straight thread. A tapered thread requires modification.

**See Appendix.

which is our job to quantify with a stated accuracy, is an average diameter of a cylinder under elastically deformed conditions. The object which currently embodies this concept is a highly finished hardened steel cylinder. The magnitude of the major errors in the object (model ambiguity) is dependent upon:

- (1) the taper (variations in diameter along the longitudinal axis)
- (2) variations from a true cylindrical contour (out of roundness)
- (3) surface finish
- (4) second order terms; i.e. various mechanical properties of the investigated object, such as the non-homogeneity of the material and the anisotropy of the elasticity, which have an effect upon the deformation properties of the cylinder. Heretofore, the magnitude of this uncertainty was assumed to be negligible.

The effect of the model ambiguity on the measurement process may be minimized by establishing certain limits:

- (1) for 60° thread measuring wires, variations in diameter over the one inch central interval of the wire shall not exceed 10 micro-inches as determined by measuring between a flat measuring contact and a cylindrical contact.

- (2) For 60° thread measuring wires, out-of-roundness shall not exceed 10 microinches over the central one inch of the wire as determined by measuring between a flat contact and a 60° V-groove. For 29° Acme, 29° Stub Acme, and Buttress thread wires, the cylindrical contour limit

should not exceed 50 microinches as determined by measuring between a flat contact and a V-groove cut on a cylinder having the same flank angles as the thread to be measured.

(3) The surface roughness rating should not exceed 2 microinches arithmetical average (AA).

(4) The wires are manufactured from high speed tool steel (M1 or M2) which results in a very uniform steel.

Only after the degree of model ambiguity is determined to be within specifications can a meaningful measurement process commence. For a wire which is to be used in measuring 60° threaded plugs, the measuring algorithm for our concept means measuring the wire diameter between a flat contact and a cylinder (with a surface roughness not greater than 2 microinches AA). The stipulated conditions for calibrating a 60° thread wire are outlined below for all USA standard 60° thread wires, 29° Acme, and Buttress thread measuring wires. (1)

<u>Pitch</u> <u>(TPI)</u>	<u>Measuring Force</u>	<u>Cylinder Size</u> <u>(Diameter)</u>
20 or less	2.5 lbs.	0.750 inch
Above 20 thru 40	1.0	0.750
Above 40 thru 80	0.5	0.125
Above 80 thru 140	0.25	0.050
Above 140	0.125	0.020

(1)From NBS Handbook H28

Wires which are to be used where the contact is line contact, such as occurs when measuring the pitch diameter of gears, are standardized at 1-pound force between plane parallel steel measuring surfaces.

When measuring a 60° threaded plug the wire presses on the flank with a force applied by the measuring instrument. Thus, it is desirable to calibrate the wire diameter under conditions which compensate for the deformation which will occur under actual use. The plane of the contacting anvil should be parallel to the cylindrical contact within 5 microinches. To avoid permanent deformation caused by exceeding the elastic limit of the wire, the measuring force must be limited.

The 60° thread wires that are used as reference masters are calibrated with an uncertainty of ± 5 microinches. The wires used for the actual measurement of gages, or working wires, are normally calibrated with an uncertainty of ± 10 microinches.

Calibration Methods

The NBS master wires are referenced back to the SI meter through interferometry utilizing the cadmium. The enclosed sample illustrates one such calibration for a 36 (TPI) wire (Fig. 2). The final diameter that will be reported is 0.016034 inch. The major sources of measurement error are random observational errors and, for larger diameter wires, poor measurements of the part temperature and ambient atmospheric conditions. The model ambiguity is negligible since uniformity (roundness and taper) checks are performed first.

In times past, the interferometric measurement was used in the calibration of all customer wires except working wires. To achieve the preassigned accuracy for reference wires, usually two or more independent measurements were required to adequately describe the process. Also, as is evident, many possibilities for error existed as well as the sheer amount of time involved for each wire calibration. There existed a definite need for a more economical and, to a large extent, self-checking system for the calibration of thread wires while maintaining overall system integrity and accuracy.

We have recently incorporated a modification of the measurement assurance program (MAP) in the calibration of customer master thread wires. This process involves a statistically based design which contains monitors of the standard deviation and other parameters of the process, while providing a check on the NBS master wires or comparator calibration. Since our NBS master wires have been calibrated a number of times over the past few years, we have a most probable value for each master which is more reliable than any single "customer calibration" value we could do. Since these measurements are spread over time, the protection against one class of systematics is assured. The process thus involves a mechanical transfer from the NBS masters to the customers' product. Since the NBS masters are measured in accordance with the specifications of H28 for the calibration of thread wires, the customer wires will be correctly assigned the appropriate diameter. The goal achieved by this system is higher overall confidence in the

assignment of diameter to the thread wires at possible reduced costs in the future for both NBS and the customer.

The actual least squares measurement process involves two NBS master wires and two unknowns with eight differences incorporated in thirty-two observations for each wire. The differences are independently designed so that drift cancellation is inherent. A computer program was developed to facilitate simple input interaction and rapid processing of the data. The output of the program gives performance parameters of the test along with finalized printout of the actual report. Human intervention is kept at a minimum which is a significant advantage.

The printout (Fig. 3) of one recent calibration is included for analysis. M1 and M2 are the NBS master wires whose dimensions are well known from previous calibrations. The sum of the masters is used in the least squares solution as a restraint and the difference is used as a check to determine if the measurement process is in statistical control. Most frequently there are two sets of test wires T1 and T2 to be calibrated and the measurement scheme is then:

M1	T1	T1	M1
M2	M1	M1	M2
T2	M2	M2	T2
T1	T2	T2	T1
T1	T2	T2	T1
T2	M1	M1	T2
M1	M2	M2	M1
M1	T2	T2	M1

where

M1 is the reading (in microinches) on a comparator for NBS master #1

M2 is reading for NBS master #2

T1 is reading for test wire #1

T2 is reading for test wire #2.

The delta column tells the observer at a glance when his observations are in statistical control by indicating how far the differences are from the least square solution. In some cases, a wire with bad geometry may be spotted here if it was missed in checking for the degree of model ambiguity. The M1-M2 column indicates the observed differences in the two NBS masters in microinches to permit a quick check of either master change or comparator scale constant drift. The Test 3 and Test 4 column is the correction value assigned to each unknown wire from the least squares adjustment of the data. The three sigma total random uncertainty in transfer is based on the established standard deviation of the instrument and the fact that one uses redundant measurements of the test wires. The next line performs various statistical checks to make sure the process is in control. The last line compares the observed check value with the accepted check value and performs a T-Test. If for any reason the process is not in control, the observer is informed and repeats the calibration. The total random uncertainty for our transfer process to date has been approximately 1.5 microinches. This value combined with the uncertainty in our masters (± 3 microinches), which may be considered the systematic component of the

process, allows us to maintain overall system accuracy of approximately ± 5 microinches for the calibration of reference wires.

Working Wires (three wire sets)

The calibration process which is currently in use for the calibration of customer "working" wires (calibrated with an uncertainty of ± 10 microinches) is a simplified mechanical transfer. It offers some of the same features of self-checking as the more elaborate system in that the three test wires are intercompared with two NBS masters which are known to the same uncertainty as the former masters. An example of the computer printout (Fig. 4) from that program with explanations is included. One expects a higher standard deviation because fewer measurements are taken. In this case we have been able to give the customer increased confidence with less time for performing the test and compiling the results.

Advantages of New Process for Calibration

of Customer Reference Wires

There is little doubt that this change makes the NBS and the customer's transfer processes simpler because mechanical comparison is much more convenient. The next question should be if the overall integrity and accuracy of the process is maintained. The answer to this question rests on experimental evidence which indicates that our transfer process is valid to approximately 1.5 microinches for various size wires; and, since the uncertainty of the NBS masters is known to be approximately ± 3 microinches, we can still retain our ± 5 microinch

accuracy for customer calibration uncertainty. Detailed evidence to support these values is available on request at NBS.

Another justification for one system versus another is usually economic justification. In view of this, a time study was initiated and the results are summarized for one wire calibration using four-color interferometry versus a two-wire calibration utilizing the "four ones" design which includes a check of the process and the masters. (The study was made on one subject and results tabulated from ten trials. Even when performed on another subject, the relative differences should remain constant with the uncertainty involved.)

The thermal equalization period during the interferometric method may seem like "dead" time, but this period is usually for calculation purposes and the value thus reflects that time. We see that a saving of approximately 25% actual man-hours involved is gained by the adoption of the new procedure.

Future Procedures

The major weaknesses in the current procedure are:

(1) An unusually large number of master wires are now being cataloged for our use. This is psychologically disturbing in that these are artifacts and would have to be reproduced if destroyed.

(2) We are still at the mercy of the four-color interferometric system for the calibration of any special wires which may arrive.

One hopeful solution which we have only briefly experimented with is the use of two different nominal masters coupled with the laser interferometer measuring system and a four-ones design for the

calibration of any wire. Here we will be limited by the geometric design of the anvils and the fitting of the data by the least squares adjustment of the 4-1 and calculation of any deformation corrections whicy may be necessary. This system becomes more appealing when one realizes that a digital/analog conversion could be used to record the data with subsequent processing of the data by computer. Thus, the ultimate device could be an automatic system utilizing the statistical design for data reduction to provide for checks of system reliability while self-checking the master wires. Until that time we will continue to upgrade our current procedures.

Conclusion

The major thrust of our revision in the calibration of thread wires has involved the switch to a statistical procedure which:

- (1) Allows higher overall confidence in the measurement process,
- (2) is economically more attractive in the calibration of certain types of wires,
- (3) is more automated in the data reduction step resulting in less possibility of human error.

In addition, a series of control charts was begun to obtain concensus values for the NBS master reference wires, and to monitor any future changes in the measuring system and/or the master wires.

Appendix

Investigated Object:

The material thing which is the subject of the measurement process.

Concept:

The parameters, length, mass, volume, etc., which appear in the equations of theoretical physics.

Unit:

The arbitrary scale on which the magnitude of the parameter is expressed.

Unit Error:

The difference between the scale on which the magnitude of the parameter is expressed and the scale on which it (arbitrarily) should be expressed.

Model:

The theory which relates a material property of the investigated object to the concept the object is presumed to embody and predicts the signal produced by the object.

Signal:

That physical property or influence by which the measuring algorithm detects and measures the embodiment of the concept of interest in the investigated object.

Model Ambiguity:

The difference between the embodiment of the concept in the investigated object to that embodiment presumed in the Model; i.e. the difference between the signal observed and the signal predicted.

Measurement Algorithm:

The prescription by which the magnitude of desired property is extracted from the object. It includes the instrument, all relevant procedures, environmental factors and calculations, etc., involved.

Algorithm Error:

The difference between the assumed response of the measurement algorithm to the signal from the object and its response during the measurement.

Measurement Station:

An independent location, apparatus or environment where a measurement algorithm is implemented.

Prototype:

An investigated object that is its own Model.

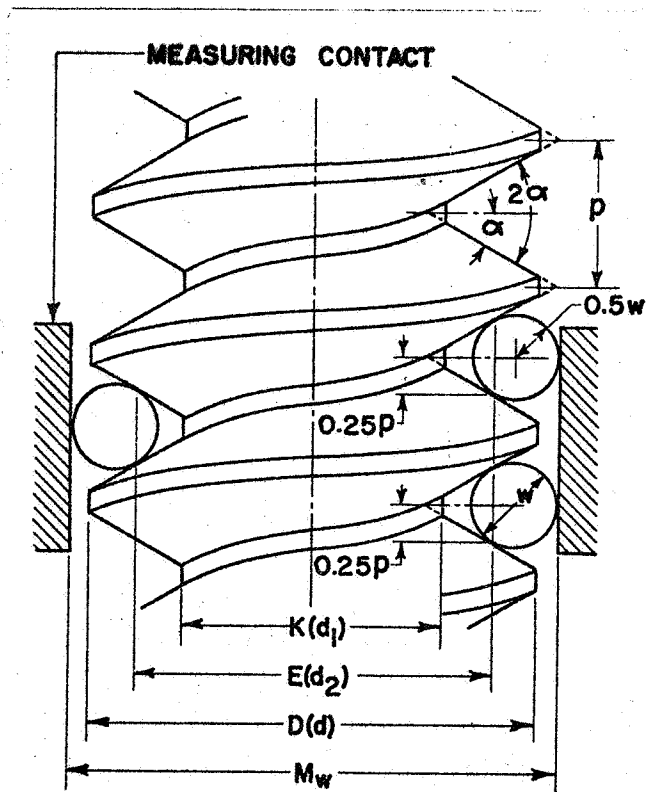

FIGURE 1

THREE - WIRE METHOD OF MEASURING PITCH
DIAMETER OF STRAIGHT THREAD PLUG GAGES.

Interferometric Measurement of a Thread Measuring Wire

Wire is measured between a flat steel contact and a 0.750" hardened steel precision cylinder under an applied force of 1.0 pound.

Nominal Size (NS) = .016040 , 36 Pitch

Cadmium Spectrum	Red	Green	Blue 1	Blue 2
Obs. Fract. (Anvil)	.25	.05	.40	.95
Obs. Fract. (Anvil and Wire)	.10	.55	.45	.80
Difference	15	50	95	15
Nom. Fractions (NF)	56	16	59	77
Obs. - Nom. $\left(\frac{a_i}{b_i} \right)$	59	34	36	38
Nom. - Obs. $\left(\frac{a_i}{b_i} \right)$	41	66	64	62

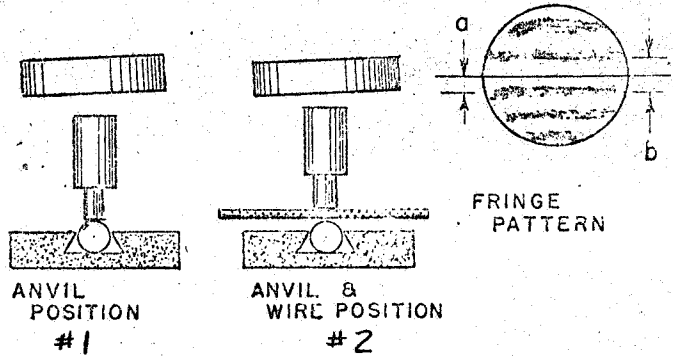

Nominal wire size (NS) .016040"
 Average deviation from nominal size -.000005"
 Thermal expansion corr. .000000"
 Wave length corr. -.000000"
 Slit & obliquity corr. 1.8 X NS + .000000"

Master wire size .016034"

Nominal fraction computation for cadmium

color	bands per inch	NS inch	orders (N)	NF
red	78,900.332 X	<u>.01604</u>	=	<u>1265.56</u>
green	99,885.021 X	<u>.01604</u>	=	<u>1602.16</u>
blue 1	105,834.73- X	<u>.01604</u>	=	<u>1697.59</u>
blue 2	108,589.37- X	<u>.01604</u>	=	<u>1791.77</u>

Conversion of order and fraction wavelength to inch

Cd	$\frac{\lambda_i}{2} (+ \text{ or } - \frac{N_i + a_i}{b_i})$	inch	μin
R	.0000127" X <u>-.41</u>	=	<u>-.52</u>
G	.0000100" X <u>-.66</u>	=	<u>-.66</u>
B1	.0000094" X <u>-.64</u>	=	<u>-.60</u>
B2	.0000092" X <u>-.62</u>	=	<u>-.57</u>
	Sum	=	<u>-.23.5</u>
$\frac{\text{Sum}}{4}$	Average deviation from nominal size	=	<u>-.59</u>
	Spread	=	<u>1.4 \mu\text{in}</u>

AMBIENT CONDITION

	reading	corr.	corr. reading
(T) temp.	<u>20.15 °C</u>	<u>+ .14</u>	<u>20.29 °C</u>
(P) barom.	<u>765.05 mm</u>	<u>- 3.15</u>	<u>761.90 mm</u>
vapor pressure	_____ °C wet		
(e)	_____ °C dry		<u>9</u> mm

T_c = Coeff. of linear thermal exp. = 11.5 $\mu\text{in}/\text{in}/^\circ\text{C}$ for steel

Wire expansion corr. = $(T_c) \times (NS) \times (20^\circ\text{C} - T) = \underline{11.5 \times .01604 \times -0.29 = -0.05 \mu\text{in}}$

Wavelength corr. = $(K) \times \text{times} \times (NS) = \underline{-0.46 \times .01604 = .0073 \mu\text{in}}$

$K = 0.36(760 - P) + 0.05(e - 10) + 0.93(T - 20) = .36(-1.9) + 0.05(-1) + .93(.29) = -0.46 \mu\text{in}/\text{inch}$

FIGURE 2

TIMEX=00001.2, HIT K, R, OR CK

?XBASIC THD41

RUN

DO YOU WISH INFO ON THE PROGRAM? (1=YES=0=NO)

!1

THIS PROGRAM IS WRITTEN TO ANALYZE 4-1 SERIES DATA FOR THE CALIBRATION OF THREAD WIRES. THE DATA IS INPUT THROUGH A SEPARATE DATA FILE NAMED DATAW.

THE PROGRAM WILL FUNCTION PROPERLY ONLY WHEN ALL FOUR WIRES HAVE THE SAME BASIC SIZE.

THE COMMAND IS CREATE DATAW, THEN BEGIN:

LINE NO PITCH

LINE NO MASTER #1 MEAS, MASTER #2, TEST #1, TEST #2

DO YOU WANT ALL OBSERVATIONS PRINTED? (1=YES=0=NO)

!0-1

CALIBRATING 60 DEG,29 DEG ACME,OR GEAR?(1=60,2=29,3=G)

!1

OBSERVATIONS

16	32	32	19
27	19	18	27
42	27	28	44
36	44	44	35
36	44	45	38
45	22	21	46
21	30	30	21
31	36	39	31

A(I)	DELTA(I)
-14.50	.708
8.50	-.083
15.50	.458
-8.50	-.083
-7.50	.917
24.00	.375
-9.00	-.417
-6.50	.125

PITCH*BEST SIZE*M1-M2***TEST-3*****TEST-4*****UNCER(3 SIGMA)*

26.0 .022206 -8.6 22.4 30.8 1.40

*OBS SD*****ACC SD*****F TEST*****F RATIO*****DEGREES OF FREEDOM

.616 .810 .578 3.02 5

OBS CORR***ACC CORR*****T-TEST

-8.583 -9.000 .891

017 BLOCKS SAVED
?XBASIC THDWE
RUN

DO YOU WISH INSTRUCTIONS? (1=YES, 0= NO)

!0

HAVE YOU CREATED YOUR DATA FILE? (1=YES,0=NO)

!1

HOW MANY WIRES EXCEED:

- (1) 10 MICROINCHES IN ROUNDNESS AS DETERMINED BY MEASURING BETWEEN FLAT CONTACT AND 60 DEGREE V-GROOVE FOR THE 60 DEGREE WIRES;
- (2) 50 MICROINCHES IN ROUNDNESS FOR 29 DEGREE ACME AS DETERMINED BY MEASURING BETWEEN FLAT CONTACT AND A 29 DEGREE V-GROOVE.

!0

TESTING 60 DEGREE OR 29 DEGREE ACME BEST? (1=60,0=29)

!1

*PITCH****SIZE****C-CORR***T1-T2***DEV FROM BWS****ACC M1-M2***OBS M1-M2

4.0	.144347	.216536	-.51	9.95	5.99	6.50
4.5	.128300	.192449	-.12	-.42	-22.98	-24.50
5.0	.115475	.173220	-1.34	5.01	-16.00	-18.00
6.0	.096232	.144358	-1.67	7.02	1.00	3.00
10.0	.057741	.086621	-2.32	6.33	2.00	2.00
11.0	.052498	.078765	-1.84	11.88	20.00	20.50
13.0	.044423	.066653	-1.00	11.96	4.00	5.00
14.0	.041250	.061891	.66	10.72	5.00	6.00
32.0	.018048	.027080	-2.34	5.48	5.00	6.00
48.0	.012014	.017999	1.17	-14.37	-10.00	-10.50
56.0	.010294	.015418	-.17	-15.57	.00	.50

STANDARD DEVIATION = 1.0 MICROINCH.

THREE SIGMA PLUS UNCERTAINTY OF MASTERS = 6.1 MICROINCHES.

AN EXPLANATION OF THE ABOVE IS AS FOLLOWS:

- SIZE IS THE AVERAGE VALUE OBTAINED FROM THE TEST.
- C-CORRECTION IS (DIAMETER*3)-(.866025/PITCH).
- T1-T2 IS THE DIFFERENCE IN VALUES OBTAINED BY CHECKING AGAINST MASTER1 VERSUS MASTER2. IF THE VALUE IS GREATER THAN 4 MICROINCHES, PLEASE RECHECK.
- DIFF FROM BWS MEANS DIFFERENCE FROM THE BEST WIRE SIZE. H28 ESTABLISHES A MAXIMUM DEVIATION OF 20 MICROINCHES. THEREFORE, CONSIDER THE UNCERTAINTY WHEN ONE WIRE SERIES IS SLIGHTLY OVER THAT LIMIT.
- ACC M1 - M2 MEANS THE CONSENSUS (ACCEPTED DIFFERENCE BETWEEN MASTER 1 AND MASTER 2.

DO YOU WISH REPORT TYPED? (1=YES,0=NO)

!0

4000 EXIT

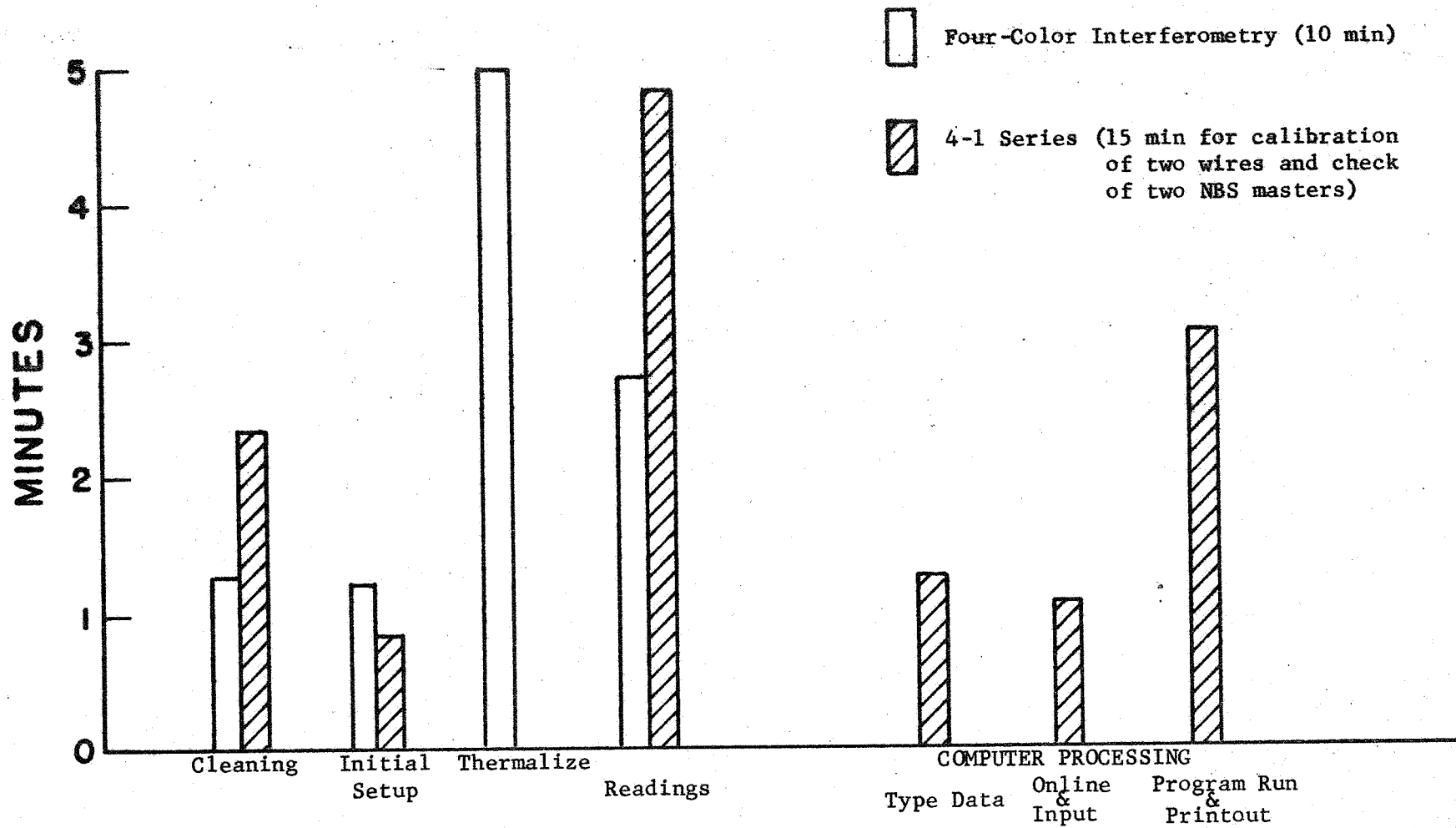

STEPS IN CALIBRATION OF WIRES

FIGURE 5

COMPARISON OF TIME FOR FOUR-COLOR INTERFEROMETRIC vs 4-1 SERIES FOR CALIBRATION OF 60° THREAD WIRES