

Final Technical Report

Laser-Based Instrumentation for Real-Time, In-Situ
Measurements of Combustible Gases, Combustion By-Products, & Suppression
Concentrations

SERDP PROJECT IDENTIFIER: 1/7, 1/78, 1/789

15 September 2002

The views and conclusions contained in this document are those of the Army Research Laboratory and should not be interpreted as representing the official policies, either expressed or implied, of the Strategic Environmental Research and Development Program.

Kevin L. McNesby, Ph.D.
Andrzej W. Miziolek, Ph.D.
R. Reed Skaggs, Ph.D.

U.S. Army Research Laboratory
Aberdeen Proving Ground, MD

*Sponsored by:
The Department of Defense
Strategic Environmental Research and Development Program*

Table of Contents

1. Title Page	1
2. Summary of Task Objectives	3
a. FY97-98	3
b. FY99-00	3
c. Technical Challenges	5
d. General Methodology	5
e. Technical Results	5
3. Detailed Description of Project	6
a. Species of Interest: Limits of Detection (LOD)	6
b. Laser Induced Breakdown Spectroscopy	6
c. 2F Tunable Diode Laser Absorption Spectroscopy (TDLAS)	7
<i>i.</i> Stand Alone Spectrometer System for HF Gas Measurement	7
<i>ii.</i> Results of HF Measurement Using Single Gas Stand Alone Spectrometer System	9
<i>iii.</i> Multi-position, Multi-gas Spectrometer System	10
<i>iv.</i> Results Using the Multi-Position, Multi-Gas Spectrometer System	11
d. Real Time Fuel/Ox Sensor	12
<i>i.</i> Background	13
<i>ii.</i> Measuring Broad Band Absorbers With Narrow Band Lasers	15
<i>iii.</i> Experimental Apparatus	17
<i>iv.</i> Results	19
e. Second Generation Sensor Development	20
<i>i.</i> Results of Prototype Testing of Second Generation Sensor System	22
<i>ii.</i> Sensitivity	23
<i>iii.</i> Future Developments	24
f. Technical Problems	25
g. Recommendations and Conclusions	25
4. References	26
5. Publications	29
6. Milestones	31
7. Significant Project Results – Discussion and Recommendations	33
8. Conclusion	34

2. Summary of Task Objectives

This final report summarizes results of a multi-year project the purpose of which was to implement laser-based instrumentation for real-time, in-situ measurements of combustible gases, combustion by-products, and suppression concentrations during suppression of flames and explosions on board Army combat vehicles. This effort directly addresses the statement of need for element 3.c of the Next Generation Fire Suppression Technology Program (NGP), administered by the DoD Strategic Environmental Research and Development Program (SERDP). The nominal project duration was from FY97 through FY99, although delays in accomplishing the goals set for the final year of the project required a no-cost extension through FY2000.

a. FY97-FY98

The first two years of the project (FY97-FY98) focused on adaptation of near-infrared tunable diode laser absorption spectroscopy (TDLAS) for measurement of byproducts produced during chemical flame suppression (e.g., HF) over a 250 ms fire suppression period, such as experienced in crew compartments of military vehicles. Part of the testing program involved evaluating rugged, low-cost fiber-optics and couplings for transporting the near-infrared laser radiation from the diode laser (located at a safe distance from the measurement location) to the measurement location, and retrieving the signal. An additional part of the program for the first two years involved the adaptation of laser induced breakdown spectroscopy (LIBS) for measuring suppression agent concentrations, starting with halogenated suppressants, and then using LIBS for measurement of oxygen concentrations.

Following laboratory characterization, these diagnostics would be installed in the crew compartment test fixture at Aberdeen Test Center for full scale fire suppressant testing. The ultimate goals of the first two years of the program were to understand why a suppressant is behaving well or poorly in full-scale suppression tests, for determining the repeatability of the tests, and for guiding optimization of agent distribution and dispersion. A simple schematic showing implementation of TDLAS and LIBS for gas measurement is shown in Figures 1 and 2.

b. FY99-FY00

The final year of the project (including the no-cost extension) concentrated on the development of a multi-point, field worthy, fiber-coupled, near-infrared tunable diode laser-based sensor for measurement and detection of combustible mixtures of oxygen and hydrocarbon fuels (heptane and JP-8). The goal of the project during this time was to build a sensor capable of quantitative measurement of fuel/oxygen concentrations before (minimum five data points prior to agent release), during, and after the suppression event

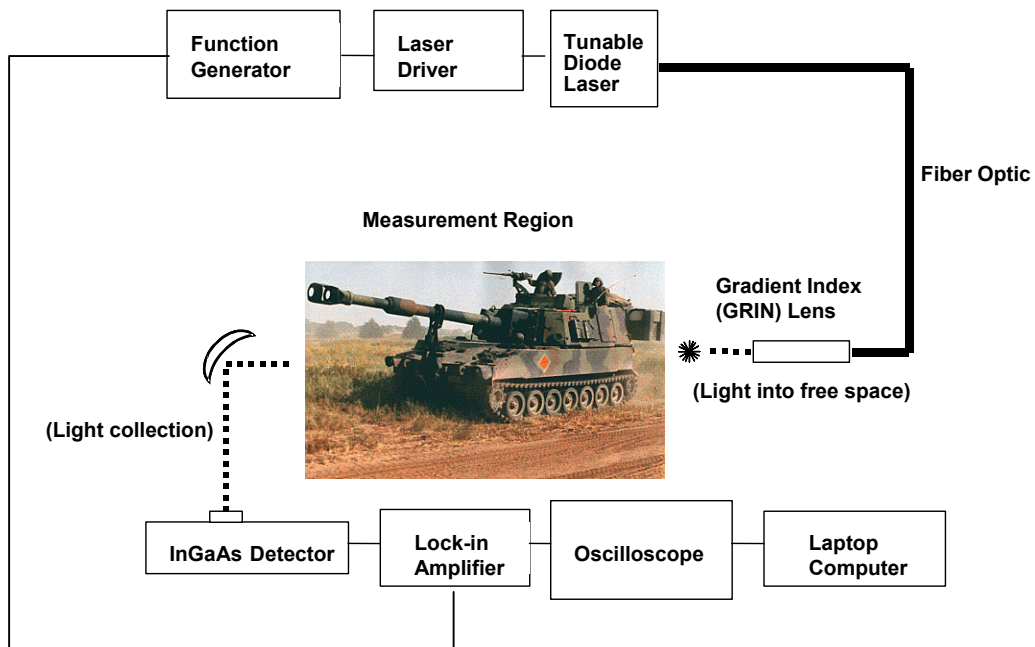

Figure 1: A schematic of a tunable diode laser absorption spectroscopy (TDLAS) measurement of gases produced during fire suppression on board Army vehicles.

(nominal event time equal to 250 milliseconds) with a time resolution better than 10 milliseconds. Detection of fuel and oxygen concentration is especially important after the suppression event in order to predict the possibility of reignition. Minimum acceptable detection limits for fuel/oxygen mixtures are approximately 600 ppm fuel (0.06%)

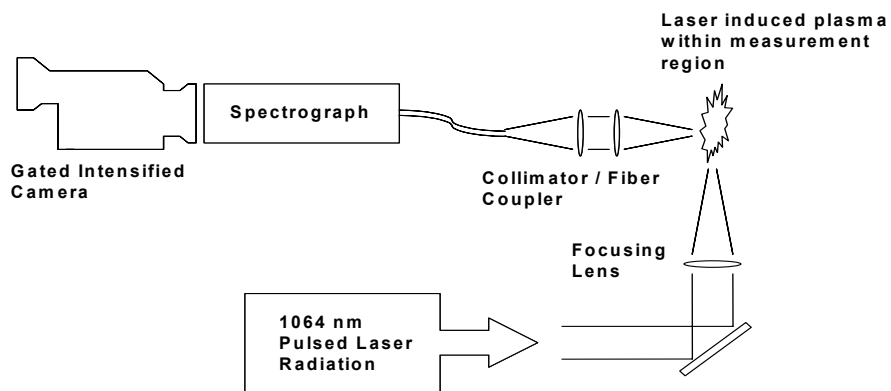

Figure 2: A schematic of a laser induced breakdown spectroscopy (LIBS) measurement for gas measurement during fire suppression on board Army vehicles.

and approximately 3000 ppm oxygen (0.3%), for a 10 centimeter pathlength at room temperature.

c. Technical Challenges

The technical challenges faced during the first two years of the project were grouped into two broad categories. First, several challenges needed to be overcome relating to the ability to measure and store data continuously with a new data point acquired every 10 milliseconds. Secondly, it was unclear how the sensor equipment would perform in the harsh environment for field testing, in which the sensor assembly in the vehicle was subjected to shock (explosion) and heat (fire). For the third year of the project, the main challenge was developing a method that enabled the narrow band light source (the diode laser) to measure a broad band absorber (JP-8 vapor), while maintaining the signal to noise enhancement achievable with phase sensitive detection. [1,2]

d. General Methodology

For the first two years of the project, the measurement techniques using near infrared tunable diode lasers were based on well established techniques [2,3] for phase sensitive detection of gases that exhibit well resolved rovibrational spectra. Typically, the protocol was measurement and calibration of a system (e.g., HF gas measurement by near-infrared TDLAS near a wavelength of 1.31 micrometers, using 2f detection) in lab, followed by reinstallation of this system at the measurement site. During this time, LIBS experiments were carried out in the laboratory to determine measurement linearity and limits of detection for gaseous fire suppressants. For the third year of the program, most of the effort was devoted to method development within the laboratory (measurement of fuel vapors using distributed feedback diode lasers), with minimum time being spent at full scale testing ranges.

e. Technical results

A brief summary of technical results (excluding publications describing this work, which are listed separately) follows:

1. Four-position near infrared tunable diode laser spectroscopy (NIR-TDLAS) system installed at the Aberdeen Test Center (ATC).
2. Tunable diode laser system for HF detection installed, calibrated, and tested in field and laboratory applications.
3. Comparative testing to determine limits of detection (LOD) of HF detection using NIR-TDLAS, FT-IR, and using ion-selective electrode completed.
4. Laboratory measurement of LIBS spectra of CF₃Br and FM-200 completed.
5. Measurement of near infrared spectra of mixtures of methane and FM-200 for single laser detection completed.
6. Field worthy, mobile tunable diode laser system, with fieldable calibration system, completed, tested for HF measurement.

7. Initial TDL-based oxygen measurements during crew compartment fire suppression system testing completed.
8. Time resolved measurements of HF dissipation during scavenging testing completed for FE-36 and FM-200.
9. Laboratory measurement of pyridine vapor using distributed feedback laser.
10. Simultaneous measurement of fuel/oxygen concentrations (100 ms per point) using distributed feedback diode laser for gasoline, DF-2, and JP-8.
11. Prototype Fourier transform laser spectrometer used to measure gasoline vapor concentrations.

3. Detailed Description of Project

In general the first two years of the project involved transitioning proven, laboratory based methods (TDLAS employing phase sensitive detection, laser induced breakdown spectroscopy) from the lab at the ARL to the crew compartment fire test facility at the Aberdeen Test Center.

a. Species of Interest: Limits of Detection (LOD)

Limits of detection (LOD) using TDLAS and using LIBS for several vapors are listed below. All LOD values listed are (to our knowledge) best achievable laboratory values. In our experience, LOD's in field measurement are always at least one order of magnitude worse than lab measurements.

<i>Method</i>	<i>Molecule</i>	<i>Wavelength</i>	<i>Approx. LOD</i>
TDLAS [4,5]	HF	1.31 um	.04 ppm-m
TDLAS [4,5]	O2	0.76 um	100 ppm-m
TDLAS [4,5]	CH4	1.65 um	.6 ppm-m
TDLAS [4,5]	CO	1.55 um	5 ppm-m
TDLAS [6]	JP-8	1.71 um	100 ppm-m
LIBS [7,8]	O2, CF3Br, CF3H	emission	1000 ppm-v

b. Laser Induced Breakdown Spectroscopy (LIBS)

A schematic showing the application of LIBS to gas measurement was shown in Figure 2. Briefly, a pulsed laser (typically Nd:YAG, pulse energy > 50 milliJoules) is brought to a focus in free space such that a breakdown occurs. The breakdown is believed to occur as follows. Initially, in the focal volume of the laser, the high electric field causes an ionization of a small number of gas molecules (usually air). Free electrons within this plasma may then absorb laser radiation (inverse Bremsstrahlung [9]) resulting in further ionization accompanied by collisional heating. Temperatures within the laser focal volume may reach 20000 K, resulting in atomization of any molecules within the focal volume [7,8]. After the laser pulse, rapid deceleration of the electrons within the plasma leads to an initial emission of broadband radiation (Bremsstrahlung

[9]) lasting tens to hundreds of nanoseconds, followed by emission of discrete wavelengths of light as the atomic species present in the plasma return to their ground states (tens to hundreds of microseconds).

The application of laser induced breakdown spectroscopy focused along two areas. First, the technique was used for measurement of linearity and determination of limits of detection for halogenated fire suppressants [7,8]. Figure 3 shows the LIBS spectra of several fluorinated fire suppressants, measured in the gas phase. The limits of detection for each gas, using LIBS, was approximately 1000 parts per million (ppm-volume). Figure 3 shows that the intensity of F emission measured using LIBS is nearly directly proportional to vapor concentration.

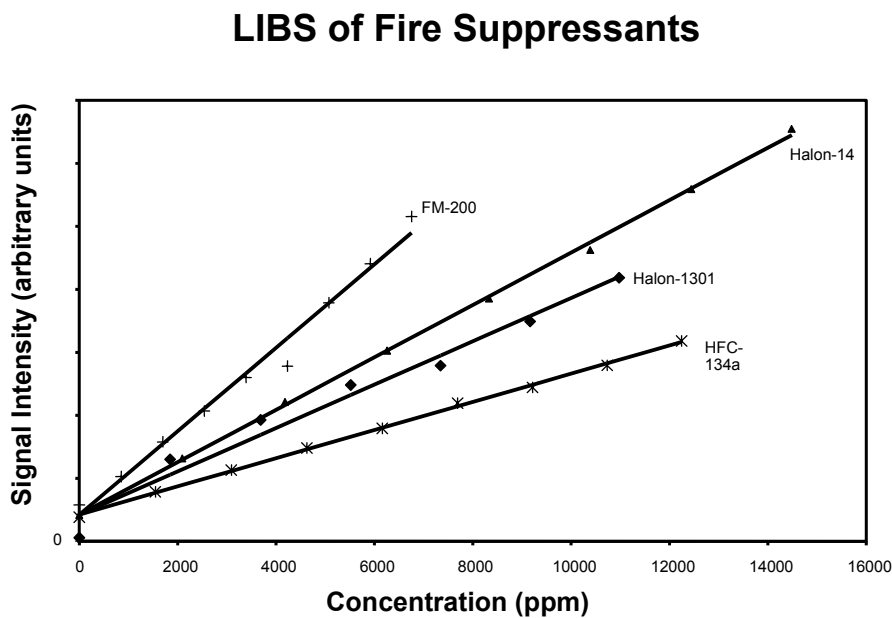

Figure 3: Laser induced breakdown spectra (LIBS) of several fluorinated fire suppressants, measured in the vapor phase. The signal intensity is the peak F emission near 400 nm.

c. 2F Tunable Diode Laser Absorption Spectroscopy (TDLAS)

i. Stand Alone Spectrometer System for HF Gas Measurement

The TDLAS effort was focused in two areas. The first of these was an effort designed to measure HF concentrations during fire suppression testing, using a stand alone spectrometer system assembled at the ARL. This system used a single, distributed feedback (DFB) tunable diode laser emitting near infrared radiation at a wavelength near

1.31 micrometers. This wavelength coincides with the P2 line of the first overtone absorption of HF gas, and is free of overlap by water lines present in most combustion environments [10]. Typically, the laser was modulated (wavelength tuned) at 100 Hz for a range of approximately 0.5 cm^{-1} , such that the center of this tuning range coincided with the center of the absorption by the P2 transition in HF gas (absorption linewidth approximately 0.1 cm^{-1}). Superimposed upon this “slow” modulation was a fast (50KHz – 100KHz) sinusoidal wavelength modulation. The wavelength range of the fast modulation was adjusted so that it was a small (<0.25) fraction of the absorption linewidth of the P2 transition (1st overtone) in HF gas. This dual modulated light beam was then launched onto an optical fiber, and the fiber used to transmit the beam from a control room (located a safe distance from the measurement site) to the measurement site. For field work, this usually meant the beam was transported approximately 100 meters to the measurement site. At the measurement site, the fiber was terminated with a gradient index (GRIN) lens, causing the light beam to be collimated while it passed through free space (the measurement region). After passing through free space for approximately 10-15 cm, the modulated light beam impinged upon a semiconductor, room temperature operation light detector (typically InGaAs). The signal from the biased (12V) photodetector was returned to the control room via a BNC cable, demodulated using a lock-in amplifier, and recorded on a laptop computer running LabView software. The amplitude (height) of the second derivative-like signal output by the lock-in amplifier was proportional to the amount of light-absorbing gas (HF) present in the measurement region. The steps involved in laser modulation and demodulation are shown in Figure 4.

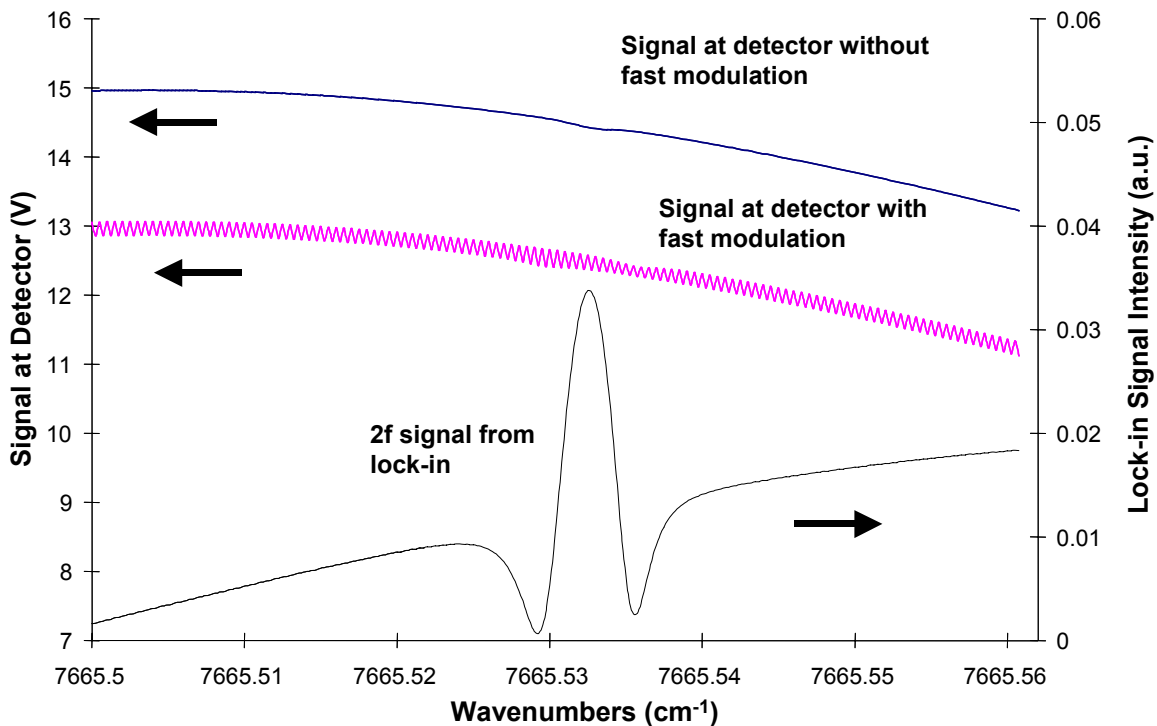

Figure 4: The signals produced at the detector as slow and fast laser modulations are combined, and the 2f signal produced by the lock-in amplifier, for a typical TDLAS measurement of HF gas.

The experimental protocol, lab results, field results, and data analysis methods are detailed in several publications[6,10-18] from our research group. Early in the experimental cycle, an effort was made to use a second optical fiber to capture the light after it had passed through the measurement region, allowing the photodetector to remain in the control room. However, it was found that the alignment of the two optical fibers for the “pitch and catch” setup at the measurement site (typically, the crew compartment of a Bradley Fighting Vehicle) was extremely sensitive. So, it was decided to place the photodetector at the measurement site, since tests showed that small misalignments in the open path fiber-to-detector line of sight were less important than small misalignments in open path fiber-to-fiber line of sight. Additionally, the costs associated with replacing either the fiber-to-detector or fiber-to-fiber setup within the vehicle were similar (hundreds of dollars). Using this system, measurement duration was 10 milliseconds (100 scans/second), however the time between measurements was approximately 100 milliseconds, caused by the delay in transferring information from the lock-in amplifier, to an oscilloscope, and from the oscilloscope to the laptop computer running LabView software.

ii. Results of HF Measurement Using Single Gas Stand Alone Spectrometer System

The single gas stand alone spectrometer system for HF gas measurement was used for three types of testing. Results from each type of testing have been reported in the open literature [10,11,15,17]. Briefly, the three tests were suppression of spark and ballistically initiated JP-8 fires (CF3Br, FM-200) in the crew compartment of a Bradley Fighting Vehicle hull, suppression of JP-8 pool fires (using a handheld extinguisher charged with FM-200), and suppression of heptane pan fires (using a mechanically actuated bottle charged with a series of fluorinated propanes). For the tests conducted in the crew compartment of the Bradley hull, measurements of HF gas (and other combustion products) were also measured using extractive Fourier transform infrared spectroscopy.

For these tests, the HF measurement location approximated the seating location of a passenger within the vehicle. Production of HF gas ranged from hundreds to thousands of ppm-m, depending on how quickly the fire was extinguished. For successful tests (fires extinguished with 250 ms of the suppressant being deployed, HF levels were typically in the hundreds of ppm range. For tests where the fire was not extinguished or suppression was not complete after 250 ms (resulting in suppressant being burned), the HF levels were often beyond the measurement range of both instruments (usually 5000 ppm for TDLAS). For the JP-8 pool fire measurements, the main goal was to obtain a measurement of the approximate exposure to HF experienced by a firefighter while suppressing the fire using a hand held extinguisher. For these tests, the HF measurement location was approximately 5 meters from the pool fire, allowing the firefighter full access to the pool fire, as he was attempting to extinguish the fire as rapidly as possible. For these tests, the HF gas concentration that was measured ranged from 0 to approximately 1000 ppm. As only one measurement site was used, the measurement was

largely a function of wind direction, although the time averaged exposure was always beyond acceptable levels.

For the heptane pan fires, an attempt was made to understand the temporal behaviour of HF gas concentration following an initial release of the commercial suppressant FE-36 (hexafluoropropane), with and without the addition of an acid gas scavenging agent that may also act as a flame suppressant (ammonium polyphosphate (APP)). The two mechanisms by which HF gas concentrations can be decreased during and following fire extinguishment by FE-36 or FM-200 are by 1) reducing the time required to extinguish the fire, thereby minimizing the time that the fluorine containing suppressant is exposed to flame temperatures, or 2) releasing a scavenging agent in conjunction with the fire suppressant chemical to remove HF after it is produced. A potential chemical scavenging agent of gaseous HF is ammonium polyphosphate (APP), which is a commercially available chemical (Phos-chek™) with fire retardant properties. One of the drawbacks to the release of a powder agent in an occupied space is the possibility of reduced visibility.

HF was produced in the full scale tests from a series of enclosed heptane/air pan fires extinguished by either FE-36 ($C_3F_6H_2$), FM-200 (C_3F_7H), FE-36 plus APP, or FM-200 plus APP. By measuring how much the HF concentrations were reduced in fires extinguished with FE-36/APP or FM-200/APP mixtures compared to fires extinguished by FE-36 or FM-200 alone, the effectiveness of APP as a HF reduction and potential scavenging agent was demonstrated. In addition, spectroscopic measurements of the amount of light attenuation (obscuration) that occurs as a hand held fire extinguisher containing powder fire fighting agent is released in the crew space of a M1 land combat vehicle were performed.

Results [17] from the full scale tests indicate that HF concentrations produced from fires extinguished by FE-36 plus APP and FM-200 plus APP were reduced in the test facility and that the presence of APP accelerated the reductions. It has been concluded that the combination of APP in an extinguisher containing FE-36 or FM-200 appears to reduce HF levels. Visibility reduction during extinguisher deployment was measured inside an actual combat vehicle for extinguishers containing FE-36 plus APP and $NaHCO_3$ plus N_2 .

Some results of these tests are shown in Figure 5. Measurements suggest that by following the temporal evolution of HF gas during fire suppression, it would be possible to determine whether the decrease in observed HF gas levels was due to acid gas scavenging or the fire being extinguished more rapidly because of the presence of the additional suppressant.

iii. Multi-Position, Multi-gas Spectrometer System

The second area of investigation involved the use of a fully automated, multi-position, multi-laser instrument housed in a small trailer adjacent to the control room at

the measurement site. This instrument, built for the Army by Southwest Sciences, Inc. (Santa Fe, NM) was originally designed to measure concentrations of CO, O₂, HF, and

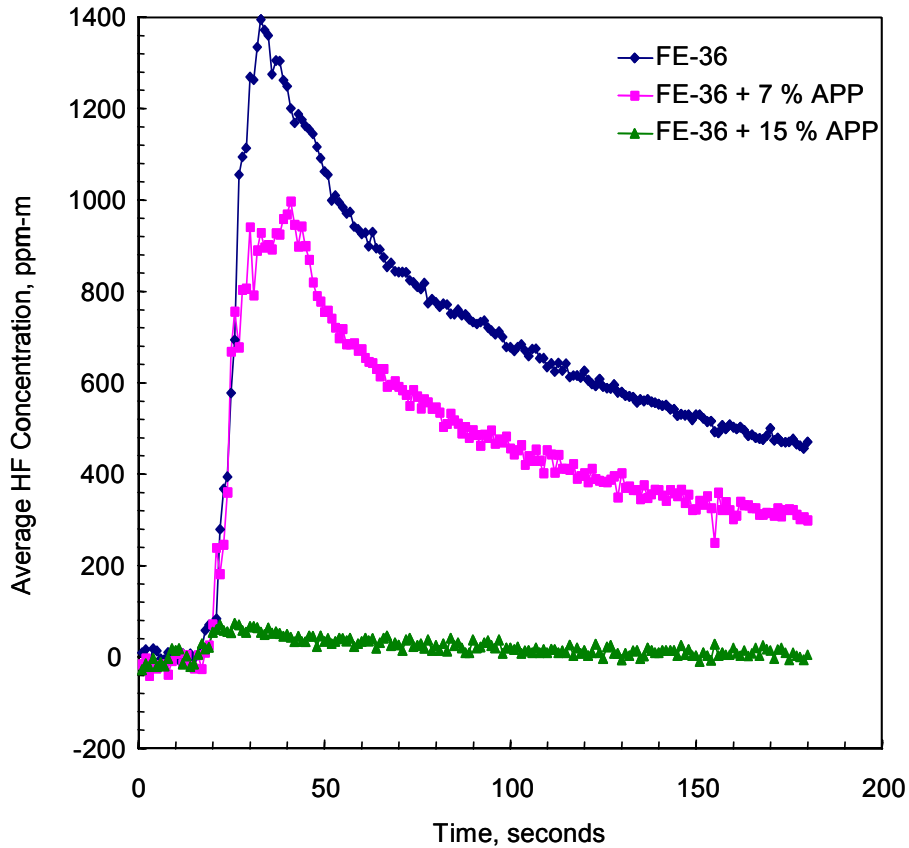

Figure 5: HF gas produced during suppression of heptane pan fires by FE-36 (hexafluoropropane) with and without the addition of APP (ammonium polyphosphate).

NO₂ at four different locations within the crew compartment of the Bradley Fighting Vehicle, achieving continuous measurement with data points every 10 milliseconds. This instrument used the same technique of dual modulation spectroscopy employed by the stand alone HF measurement system described earlier, but used a 10 KHz ramp for the “slow” modulation and a 1MHz sine wave for the “fast” modulation. During the course of development of this instrument, it was decided to focus exclusively on measuring HF and O₂ within the Bradley hull, during suppression by FM-200 of spark and ballistically initiated JP-8 fires.

iv. Results Using the Multi-position, Multi-gas Spectrometer System

Results using this system have been reported [10], but were limited to oxygen and HF measurements during chemical suppression of spark initiated P-8 fires. For these fires, a heated (~70 centigrade) spray of JP-8 liquid was begun within

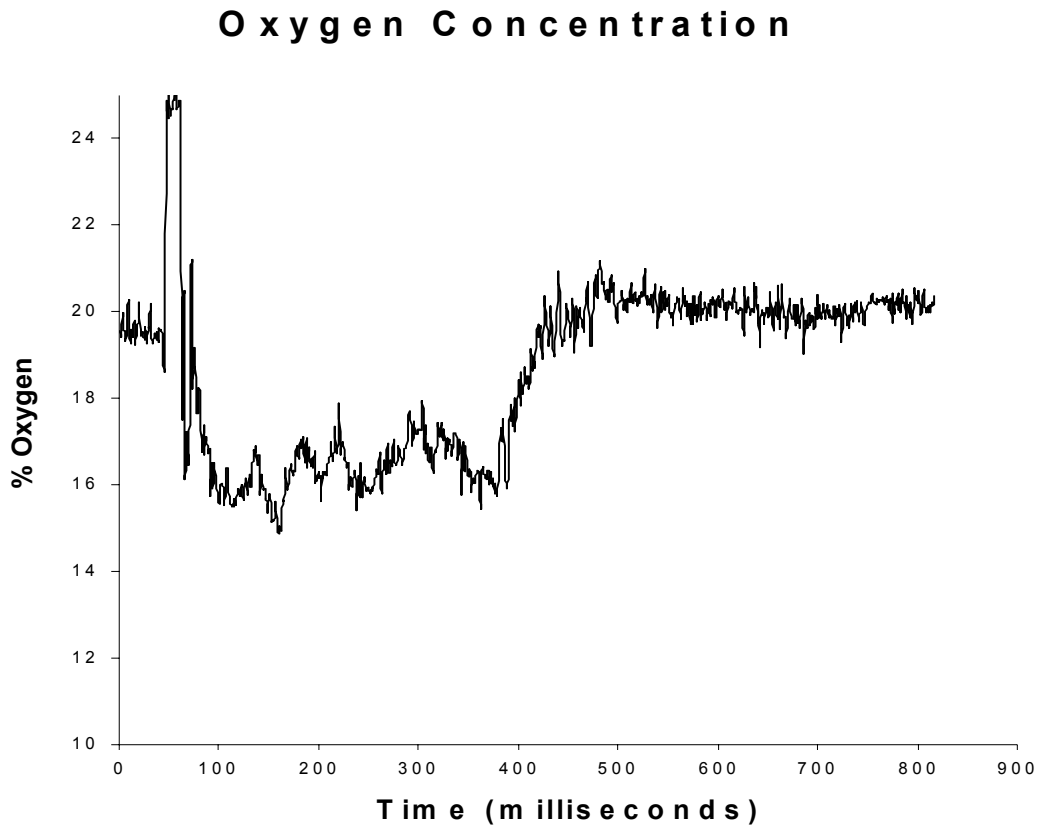

Figure 6: Oxygen concentration measured within the crew compartment of a Bradley Fighting Vehicle during suppression (by C_3F_8) of a spark initiated JP-8 spray fire.

the crew compartment of the Bradley hull (fuel nozzles located along one interior wall), and one second later this fuel spray was ignited by a series of spark plugs located along the wall of the interior of the vehicle. Approximately one second after ignition, the two onboard bottles containing the pressurized suppressant (FE-36 (C_3F_6H), FM-200 (C_3F_7H), C_3F_8) were released. At the crew seating location, a sharp drop in O_2 concentration occurred during the fire and suppression event. Following suppression, O_2 levels returned to ambient in a few seconds. It was not clear whether the decrease in O_2 levels during the fire and suppression event was due to combustion of oxygen or displacement of oxygen by the hot fuel vapors/expanding FM200 vapor. Results from a typical test measuring oxygen concentration as a function of time in the crew compartment of the Bradley fighting vehicle are shown in Figure 6.

d. Real time Fuel/Ox sensor

The last year of the funded project (FY99), plus almost a year (FY00) of additional work resulting from a no-cost extension, concentrated on measurement of

fuel/air mixtures using “real” fuels, e.g., JP-8 turbine fuel. Specifically, the work concentrated on development, within an initial one year period, of a multi-point, field worthy, fiber-coupled, near-infrared tunable diode laser-based sensor for measurement and detection of combustible mixtures of oxygen and hydrocarbon fuels (heptane and JP-8). The goal of this work was to provide quantitative measurement of fuel/oxygen concentrations before (minimum five data points prior to agent release), during, and after the suppression event (nominal event time equal to 250 milliseconds) with a time resolution better than 10 milliseconds. Detection of fuel and oxygen concentration is especially important after the suppression event in order to predict the possibility of reignition. The goal for the system was a LOD for fuel vapors of approximately 600 ppm fuel (0.06%) and approximately 3000 ppm oxygen (0.3%), for a 10 centimeter path length at room temperature.

The desired LOD for O₂ gas was routinely achievable using the TDLAS techniques described previously. The main challenge for the remaining year was the measurement of fuel vapors.

i. Background

Field worthy detectors for hydrocarbon vapor measurements typically rely upon infrared absorption (DOAS (differential optical absorption spectrometry), FT-IR (Fourier transform infrared) emission/absorption) [19,20] or electrochemical / electrothermal techniques [21]. These methods give good results, but have found limited use for measurements in fires. FT-IR and DOAS spectrometers are usually bulky, expensive, measurements require placement/alignment of interferometer/source optics and detector or retro-reflector, and are generally limited to a single line of sight. Placement of the instrument within the test environment (crew compartment) is not feasible (potential damage), looking across the entire measurement space does not isolate the region of interest, and although extractive sampling has been shown to be useful [22], it does not provide necessary temporal information. Additionally, the interferometer temporal resolution is limited by the mirror scan speed (although some new designs are approaching scan rates near 1 KHz) [23].

Nevertheless, use of FTIR and DOAS for measurement of the fundamental C-H stretch in hydrocarbon fuels near 3.4 μm can yield sensitivities in the parts per billion (ppb) range, and because the full spectrum may be measured (when using FT-IR), it is often possible to determine species of hydrocarbons present in a simple mixture. For stable, relatively safe sampling sites with an accessible line of sight, incoherent infrared absorption techniques (FT-IR, DOAS) are often the techniques of choice. Electrothermal/electrochemical detectors are generally inexpensive (\$2-5 thousand), are often one-man portable, and have sensitivities (~100's of parts per million (ppm)) well below lower explosion limits for most hydrocarbon vapors [24]. Time sensitivity is typically from 1 to 15 seconds. Some units may have accuracy problems when used in the presence of methane gas, and may be less sensitive to heavier hydrocarbon vapors [21]. For measurement sites requiring full portable instrumentation with time resolution from one to tens of seconds, these instruments can also provide excellent results.

Gas detection methods using near-infrared tunable diode lasers can use optical fibers and relatively inexpensive (room temperature operation) semiconductor detectors to separate electronics and laser sources from hazardous testing locations. Using modulation techniques and phase sensitive detection methods, temporal resolution routinely exceeds 1 ms per measurement. As previously mentioned, detection methods employed (typically wavelength modulation spectroscopy (WMS) and balanced ratiometric detection (BRD) techniques) [2,3] give good results for gas phase concentration measurements of small molecules with well resolved ro-vibrational absorption lines, such as hydrogen fluoride, methane, carbon monoxide, water, etc [25]. However, large and/or heavy molecules may not possess well resolved ro-vibrational absorption bands because of overlap between fundamental, combination, and/or overtone vibrations, and because of rotational constants which may be less than typical gas phase linewidths [26]. For mixtures of heavy molecules, e.g., the middle distillate fuels, the spectra may be even less structured. Figure 7 shows the near-infrared gas phase absorption spectrum of dry air saturated at 294K by the hydrocarbon fuels JP-8, DF-2, and gasoline (0.75 meter optical path), measured using a Fourier transform spectrometer.

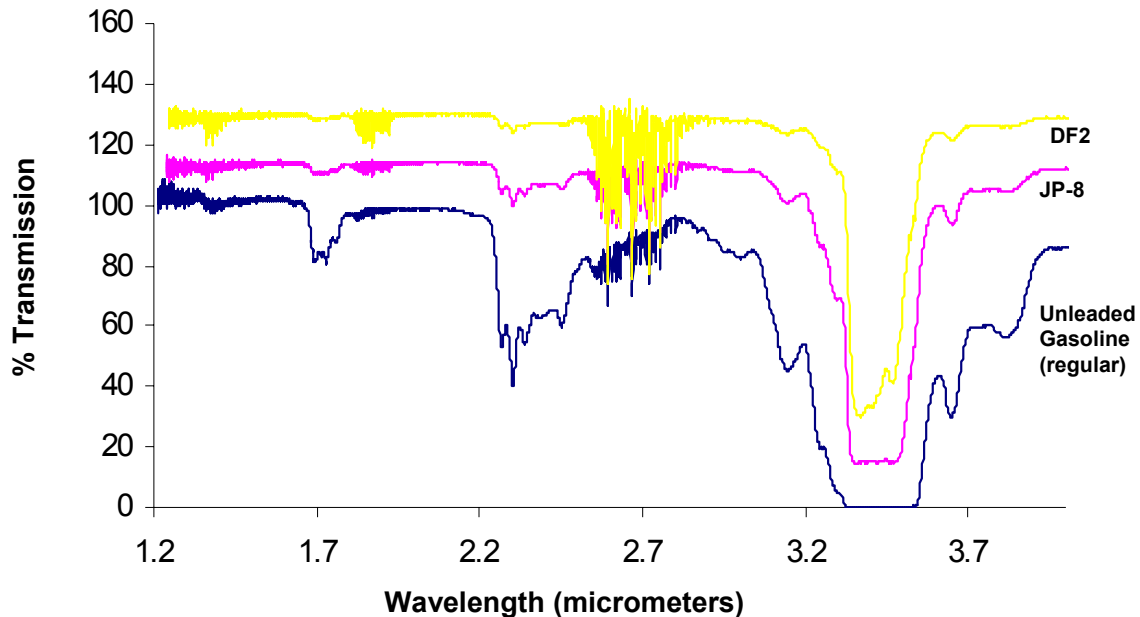

Figure 7: FT-IR spectra of dry air saturated at 294K with vapor from unleaded gasoline, JP-8, DF2. Spectra offset for clarity. Structured absorptions near 1.9 and 2.7 micrometers are from water vapor.

As suggested by the spectra shown in Figure 7, the vapors from each fuel fit criteria [27] to be classified as a gas having unstructured absorption spectra (often called a "broad band absorber"). Both WMS and BRD, as usually employed, are not suitable for gases that exhibit broad, unstructured absorption spectra [2,3,25]. For both

techniques, the main limitation for fuel sensing is the narrow tuning range of the diode laser. Because the tuning range of the DFB lasers is usually several orders of magnitude smaller than the width of the spectral feature in broad band absorbers (0.4 cm^{-1} vs. $>100 \text{ cm}^{-1}$), it is not possible using commercially available DFB lasers to tune from the region of maximum absorption to a region of zero absorption. A main goal of the project was to overcome this limitation for measurement of such molecules, while approaching the sensitivity and time response of WMS and BRD methods.

ii. Measuring Broad Band Absorbers with Narrow Band Lasers

The initial method developed for the project takes advantage of the residual amplitude modulation (RAM) that occurs as the wavelength of a semiconductor tunable diode laser is varied by modulating the laser injection current. Typically (for WMS and BRD), RAM is a nuisance, and what is important is the wavelength modulation. For this method, the RAM is what enables the technique to work, and the (relatively) small variation of wavelength during the modulation is largely ignored (but will be commented upon later). For this method, two different DFB lasers are driven using a sinusoidally varying injection current. Each laser injection current is modulated at the same frequency but out of phase by 180 degrees [27]. These light output of the two lasers is combined to produce the probe beam used for the line-of-sight measurement. When the power output amplitudes of each sinusoidally modulated laser are the same, the combined output of the two lasers will have an amplitude that is (ideally) invariant with time. The key to the method is selection of one laser wavelength coincident with a wavelength absorbed by the gas of interest, and selection of the second laser wavelength in a region where no absorption is anticipated. When the mixed, modulated probe beam is passed through a gas which preferentially absorbs the laser radiation from only one of the lasers, the signal at the detector is modulated at the injection current modulation frequency and, for small absorptions, has an amplitude whose magnitude is proportional to the concentration of absorbing gas.

The simple mathematical description begins by considering Beer's law [1] for narrow band laser radiation exiting an absorbing sample gas of concentration c molecules per cm^3 , for a path length of l cm. The absorption coefficient ($\text{cm}^2/\text{molecule}$) at the most intense region of absorption (the resonant wavelength, λ_R), is $\alpha(\lambda_R)$. $I_0(\lambda_R)$ is the intensity of the incident radiation at the resonant wavelength. $I(\lambda_R)$ is the intensity of radiation at the resonant wavelength after exiting the sample gas:

$$I(\lambda_R) = I_0(\lambda_R) \exp(-\alpha(\lambda_R)cl) \quad (1)$$

If the incident radiation at the resonant wavelength is now power modulated sinusoidally at frequency a , and time t , with depth of modulation D_R , the intensity of the radiation at the resonant wavelength after exiting the gas becomes:

$$I(\lambda_R) = I_0(\lambda_R)(1 + D_R \sin(at)) \exp(-\alpha(\lambda_R)cl) \quad (2)$$

To get a measurement of transmission off resonance (important to generate a differential signal and to discriminate against scattering by particles such as smoke), we add a second laser source at a wavelength not absorbed by the gas, λ_{NR} . This non-resonant wavelength is mixed with the resonant wavelength, power modulated at the same frequency but 180 degrees out of phase with the resonant wavelength modulation, and has a depth of modulation D_{NR} . If the radiation exiting the gas is now focussed on an (ideally) wavelength-insensitive detector, the power at this detector, $I(\lambda_R + \lambda_{NR})$, may be given by:

$$I(\lambda_R + \lambda_{NR}) = [I_0(\lambda_R)(1 + D_R \sin(at)) \exp(-\alpha(\lambda_R)cl) + I_0(\lambda_{NR})(1 + D_{NR} \sin(at + \pi))] \quad (3)$$

To process this signal, we multiply by a reference sine wave of amplitude p in phase with and at the same frequency, a , as the power modulation of the two lasers. We then integrate over C periods of power modulation:

$$C \int_0^\pi \{ [I_0(\lambda_R)(1 + D_R) \exp(-\alpha(\lambda_R)cl) - I_0(\lambda_{NR})(1 + D_{NR})] \sin(at) p \sin(at) \} dt \\ = (C/2) p \pi [I_0(\lambda_R)(1 + D_R) \exp(-\alpha(\lambda_R)cl) - I_0(\lambda_{NR})(1 + D_{NR})] \quad (4)$$

Rearranging, assuming $\exp(-\alpha(\lambda_R)cl) \ll 1$ and using A (Absorbance) is equal to $\alpha(\lambda_R)cl$:

$$2C \int_0^\pi \{ [I_0(\lambda_R)(1 + D_R) \exp(-\alpha(\lambda_R)cl) - I_0(\lambda_{NR})(1 + D_{NR})] \sin(at) p \sin(at) \} dt \\ = C p \pi [I_0(\lambda_R)(1 + D_R) - I_0(\lambda_{NR})(1 + D_{NR}) - I_0(\lambda_R)(1 + D_R)A] \quad (5)$$

For the special case where the power and depth of modulation of the two lasers are equal, Equation 5 becomes:

$$2C \int_0^\pi \{ [I_0(\lambda_R)(1 + D_R) \exp(-\alpha(\lambda_R)cl) - I_0(\lambda_{NR})(1 + D_{NR})] \sin(at) p \sin(at) \} dt \\ = -C p \pi [I_0(\lambda_R)(1 + D_R)A] \quad (6)$$

Equation 6 is just the output of a lock-in amplifier operating on the first harmonic for measurement of the amplitude of the sine wave created by the differential absorption (for small absorptions) of the mixed laser beam by the gas at concentration c and path length l . This output is proportional to the number of periods, C , over which the integration is carried, the amplitude, p , of the reference sine wave, the incident power, $I_0(\lambda_R)$, of the laser at the resonant wavelength, and the Absorbance, A (and hence gas concentration when pressure broadening of the spectral feature is not important). It is worth noting that Equation 6 also indicates that lock-in output is increased by increasing depth of modulation (D_R). As will also be discussed later, Equation 5 shows that it is important that the two laser power amplitudes and depths of modulation are as equal as possible, especially for small values of Absorbance. As mentioned previously, and implied by Equation (6), because the measurement relies on differential absorption to quantify gas concentrations, division of the raw signal at the detector by the average laser power should account for pseudo wavelength-independent signal intensity extinction from scatterers, such as smoke particles. However, it should also be mentioned that decreases in overall signal voltage will result in similar decreases in the signal to noise ratio of the measurement.

iii. Experimental Apparatus

A diagram of the experimental apparatus employing this method is shown in Figure 8. The two DFB laser diodes (Sensors Unlimited) used to produce the mixed wavelength probe beam have nominal wavelengths of 1.307 μm and 1.71 μm . The laser diodes are driven using an ILX LDC-3900 modular laser diode controller. The variable phase sinusoidal injection currents are supplied by two SRS Model DS345 function generators operating on a common timebase, Sinusoidally modulated (100 KHz, modulation depth adjusted to near 100%) laser diode radiation from each diode laser is mixed onto a common fiber using a fiber optic coupler (Gould Fiberoptics) and launched into free space using a single mode fiber that is terminated by a gradient index (GRIN) lens (Sentech Corp.). The output beam is directed into a variable pathlength gas cell (Laser Photonics L5210) set at the minimum setting of 4 meters. Radiation exiting the 4 meter path length cell is detected using a New Focus Model 2034 InGaAs large element photodetector (maximum responsivity near 1600 nm). The detector signal is demodulated at the laser injection current modulation frequency using a lock-in amplifier (SRS 830), displayed on an oscilloscope (LeCroy 7200), and recorded on a laptop computer (Dell Latitude) running LabView software (National Instruments). JP-8 and

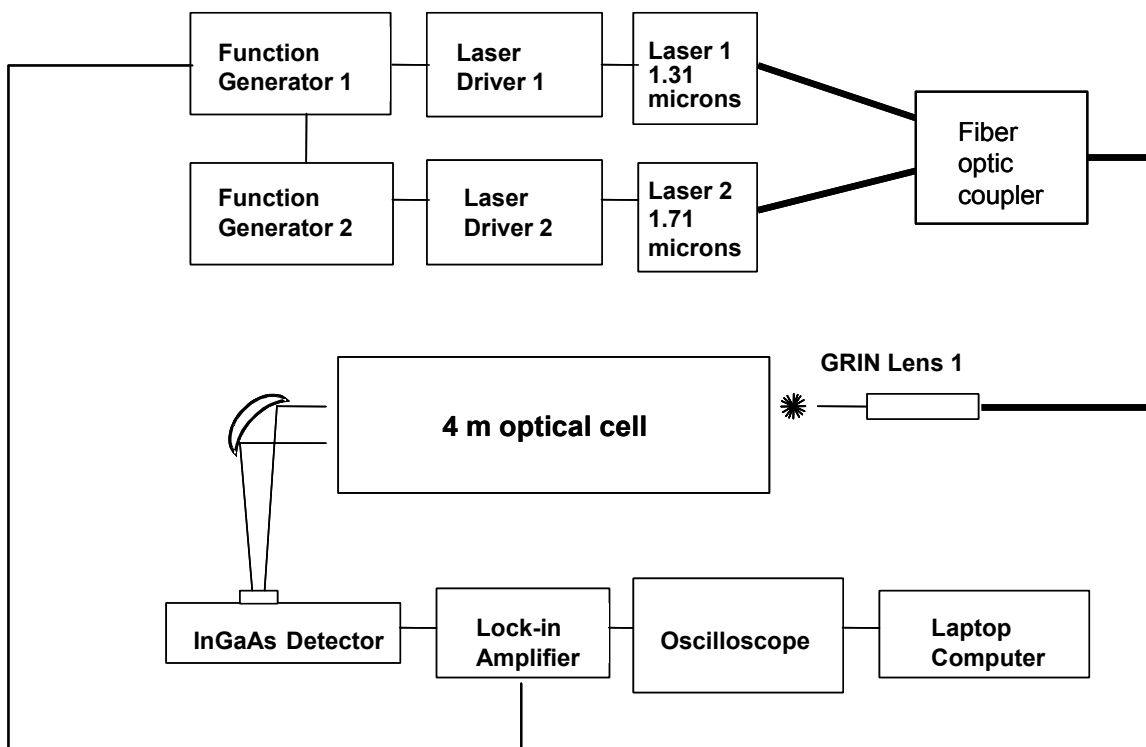

Figure 8: A diagram of the laser mixing apparatus used to measure fuel vapor concentrations.

DF-2 were milspec grade and obtained from the fuel depot at the Aberdeen Proving Ground. The gasoline was regular grade obtained during the summer months at a commercial vendor in Aberdeen, MD. All were used as supplied. Air was saturated with fuel vapor using a bubbler apparatus based upon a nitrogen sparger. Air flow through the stainless steel frit immersed in the fuel was typically 100-250 cm³/minute. Near infrared spectra shown in Figures 1 and 3 were recorded using a Bomem DA-8 (using a liquid nitrogen-cooled InSb detector) interfaced to a Wilkes 0.75 meter path length cell.

iv. Results

Figure 9 shows the vapor phase absorption spectrum of air saturated by vapor at 294K from JP-8, DF-2, and gasoline between wavelengths of 1.3 and 1.75 μm superimposed upon the emission from the optical fiber carrying the mixed wavelength laser beam. Both sets of spectra were measured using a FT-IR spectrometer (Bomem DA-8). The near infrared tunable diode laser radiation was transported using optical fibers to the external source port on the FT-IR spectrometer. This figure shows that the emission of the laser at 1.71 μm falls near the most intense region of the C-H stretch (first overtone) absorption for the three fuels studied, and that the 1.3 μm laser falls in a region where there is no measurable absorption of the laser radiation by the fuels studied. Because of the narrow emission linewidth of the lasers, the reported lineshape in this figure is just the instrument lineshape (in this case, sinc) of the FT-IR spectrometer [28].

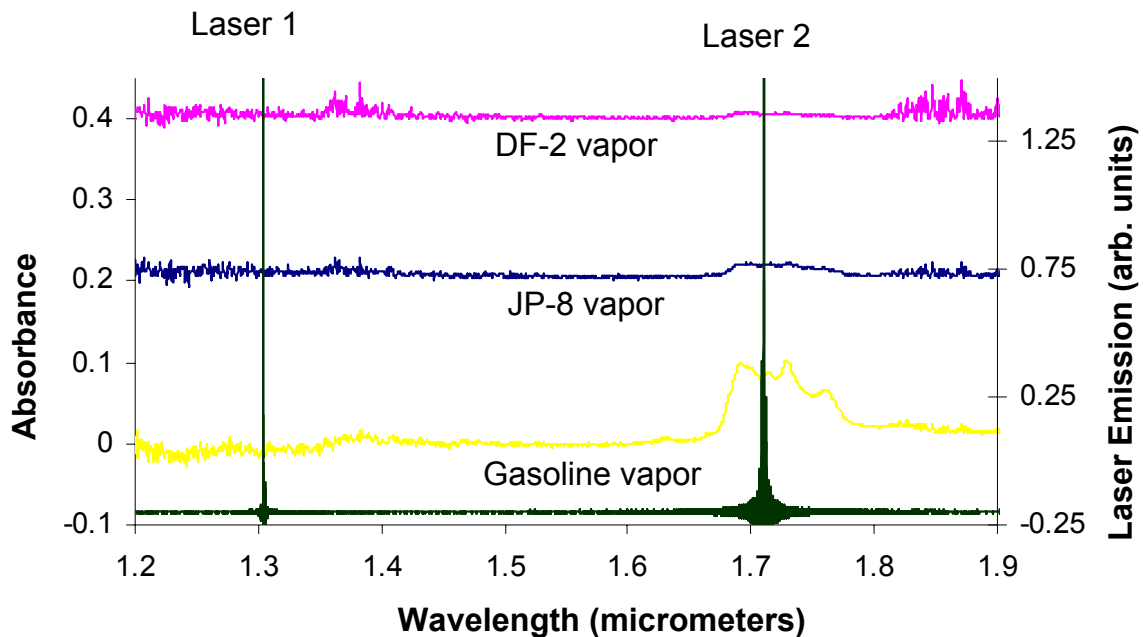

Figure 9: The vapor phase absorption spectrum of air saturated by vapor at 294K from JP-8, DF-2, and gasoline between wavelengths of 1.3 and 1.75 μm superimposed upon the emission from the optical fiber carrying the mixed wavelength laser beam.

Figure 10 shows the gasoline vapor concentration (measured using the mixed laser sensor) as dry air saturated by gasoline vapor slowly displaces (several hundred $\text{cm}^3/\text{minute}$) the dry air in a 13.7 liter volume optical cell (4 meter path length). Also shown in this figure is the change in oxygen concentration that occurs during the displacement (DFB laser- based oxygen sensor courtesy of Oxigraf, Inc., Mountain View, CA). This figure shows the sensor response as the vapor concentration approaches and exceeds the lower explosive limit (LEL) for most hydrocarbon vapors (e.g., for JP-8 the LEL is approximately 9500 ppm [24,29]). Each data point is the average of the lock-in amplifier output measured over 10 ms. All measurements were made at atmospheric pressure.

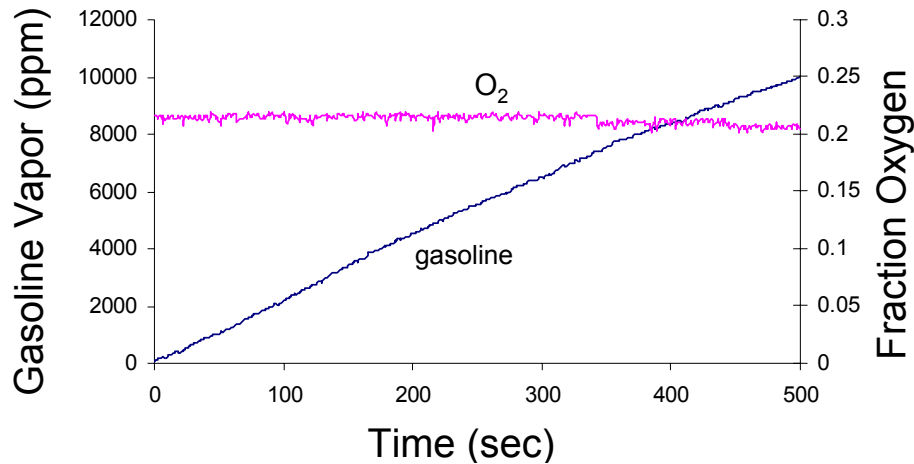

Figure 10: Gasoline vapor concentration (measured using the mixed laser sensor) as dry air saturated by gasoline vapor slowly displaces (several hundred $\text{cm}^3/\text{minute}$) the dry air in a 13.7 liter volume optical cell. Also shown in this figure is the change in oxygen concentration that occurs during the displacement (DFB laser- based oxygen sensor courtesy of Oxigraf, Inc., Mountain View, CA).

Figure 11 shows the measured fuel vapor concentration as the dry air in the 13.7 liter volume optical cell is displaced by air saturated (at 294K) by JP-8 vapor. The difference in peak hydrocarbon levels between runs shown in Figure 11 is caused by the gradual removal of lighter hydrocarbons from the JP-8. For brevity, results on DF2 are not presented, since the results for DF-2 were similar to those for JP-8. The partial pressures at atmospheric pressure (measured using a capacitance manometer) for gasoline, JP-8, and DF-2 fuels were found to be approximately 13, 3.5, and 1.75 torr ($\pm 20\%$), respectively. We measured the C-H stretch first overtone absorption coefficient for the fuel vapors to be approximately $2.7 (\pm 4) \times 10^{-21} \text{ cm}^2/\text{molecule}$, which is in reasonable agreement to that for the first overtone of the C-H stretch for methane ($8.7 \times 10^{-22} \text{ cm}^2/\text{molecule}$) [4]. We estimate the limit of detection for each of these fuel vapors, using the mixed laser sensor, to be approximately 100 ppm-meter.

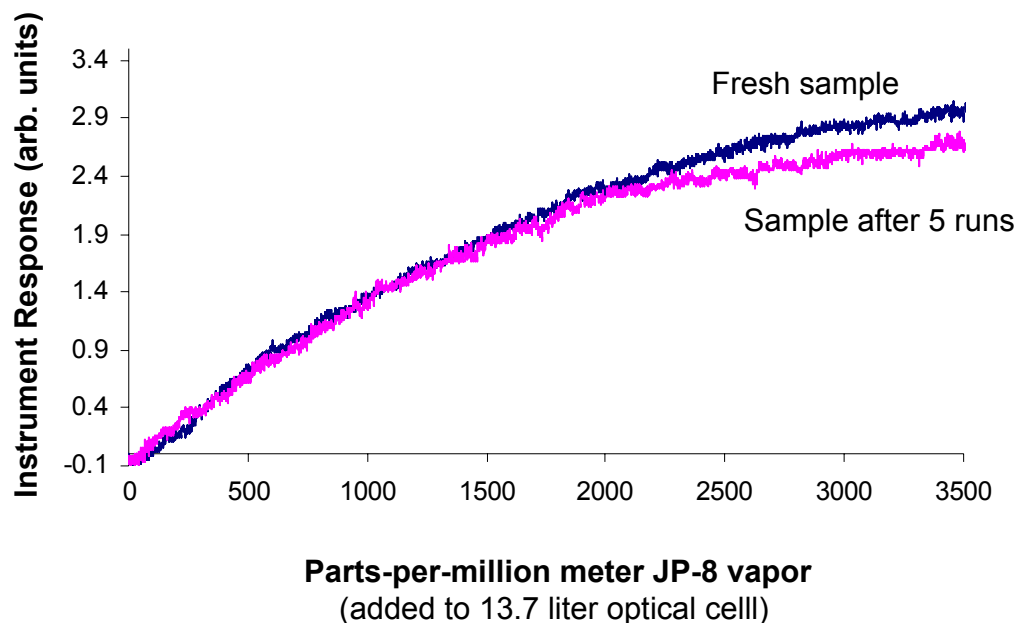

Figure 11: Ageing of JP-8 (loss of lighter hydrocarbons) caused by repeated fills of the optical cell used for testing the mixed laser fuel vapor sensor.

Two factors led us to decide that measurement of the full absorption envelope for the C-H stretching vibration was necessary, and that our first generation sensor system was inadequate for general fuel vapor sensing. First, careful examination of the C-H overtone bands for each of the fuels tested (JP-8, diesel, and gasoline) shows that the contours of the absorption features, when normalized to each other, were not superimposable. So, being limited to sampling vapors from different fuels using the same single wavelength would be a potential source of error. Second, changes in temperature, storage conditions (ageing) and changes in fuel composition between vendors may cause changes in the contour of the unstructured absorption envelope. Therefore, it was necessary to develop a technique with the simplicity of the first generation sensor but with the capability of expansion to measure the full C-H absorption envelope of the fuel vapor.

e. Second Generation Sensor Development

Perhaps the best method for detection and measurement of vapor phase “broad band” absorbers is Fourier transform infrared (FT-IR) spectroscopy [28]. In conventional Fourier transform spectrometers, each “discrete” wavelength of light emitted by the glowbar source (most Fourier transform spectrometers use a resistively heated tungsten coil) is power modulated by a Michelson interferometer so that the output, as measured at the detector, is sinusoidal, with a frequency in the KHz (acoustic) range. The amplitude and frequency of this cosine wave are a function of moving mirror displacement and of the wavelength of the incident light. As an example of the relationship between spectral resolution and mirror displacement, to resolve the line separation of the fundamental ro-vibrational transition in CO gas it is necessary to move

one of the mirrors in the interferometer approximately 1 cm. Although highly refined, the net effect of this design is to limit the use of these instruments mainly to the laboratory, necessitate complicated electromechanical mirror transport systems, and limit measurement applications to repeatable or static events. Details of FT-IR spectroscopy are widely available in several standard texts on the subject [30].

The approach employed in our second generation sensor uses an array of addressable microphotonic semiconductor lasers, each emitting light at a different wavelength, and power modulated at different frequencies (typically between 100 and 150 KHz). When the modulated light is combined onto a single path, and the combined beam brought to focus on a detector, the signal reported by the detector has the contour of an interferogram. This interferogram is analyzed by standard Fast Fourier Transform (FFT) techniques to yield the amplitudes of the individual component cosine waves [31]. These amplitudes are proportional to the average power of light at each wavelength reaching the detector. Figure 12 shows the interferogram generated by a two laser mixed beam. Laser 1 emits radiation near a wavelength of 1.31 micrometers and was power modulated at 100 KHz, with a depth of modulation near 95%. As with the first generation sensor, this laser wavelength was chosen because it is not absorbed by hydrocarbon vapor or by water vapor. Laser 2 emits laser radiation near a wavelength of 1.71 micrometers and was power modulated at 110 KHz, with a depth of modulation near 95%. Also as with the first generation sensor, this laser wavelength was chosen because it is approximately at the center of the 1st overtone C-H stretching vibration of most middle distillate fuel vapors.

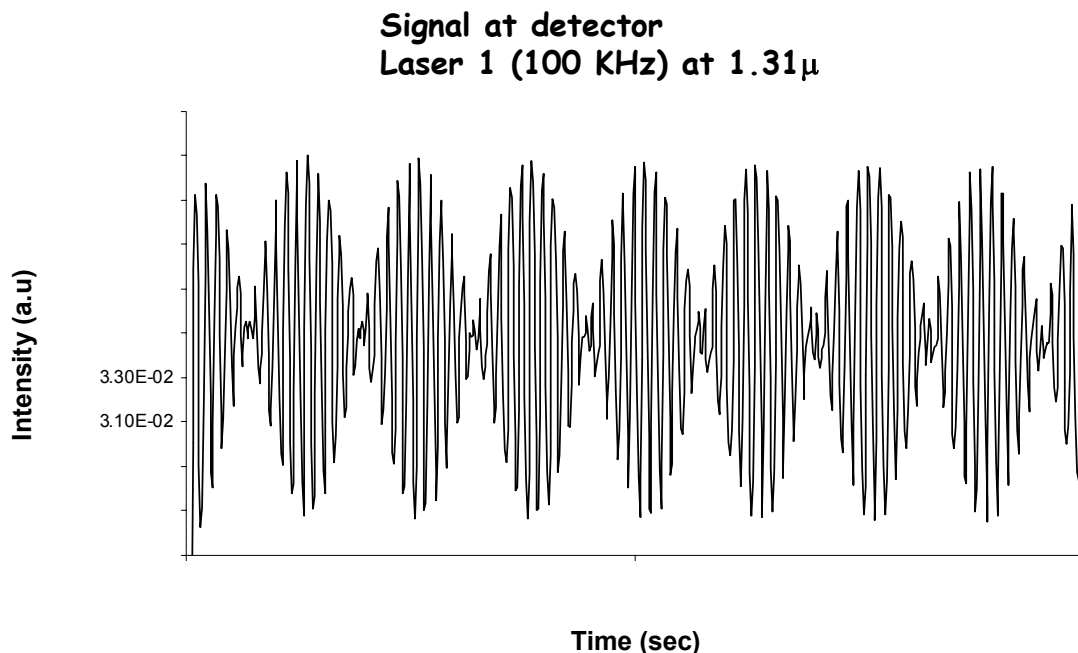

Figure 12: The two laser interferogram measured at the detector for the second generation fuel vapor sensor.

The output from each fiber coupled laser is launched onto a single, common, single mode optical fiber using a commercially available fiber coupler (Gould Fiber Optics). Each laser is power modulated, each at a different frequency, using digital function generators (Stanford Research Systems DS-345) operating on a common time base. This modulated light beam is passed through a GRIN lens into free space, and the transmitted light detected using an InGaAs (New Focus model 2011) detector. The signal at the detector is demodulated (Agilent Infinium Oscilloscope) using a Fast Fourier Transform (FFT), in a manner similar to that of commercially available Fourier transform infrared (FT-IR) spectrometers [31]. Time for each measurement is user controlled by varying the frequency of power modulation. Resolution is user controlled by varying the number of periods of power modulation measured per “scan”. The experimental apparatus for the Fourier transform laser spectroscopy (FT-LS) system is described in Figure 13.

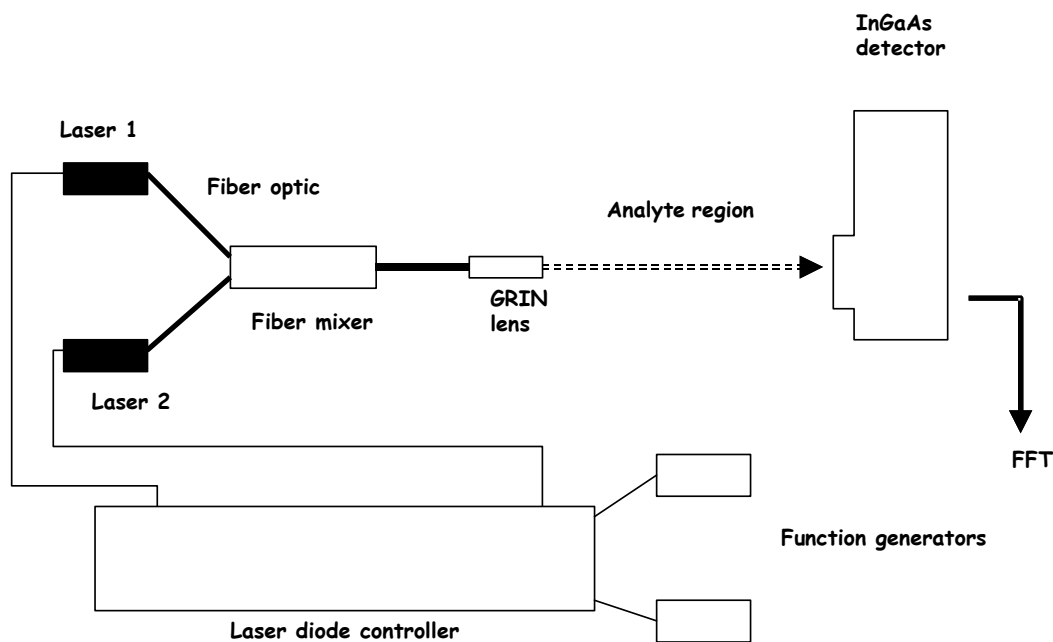

Figure 13: A schematic of the experimental apparatus used for Fourier transform laser spectroscopy (FT-LS).

i. Results of Prototype Testing of Second Generation Sensor System

As with the first generation sensor, the second generation sensor was tested by measuring gasoline vapor concentration as dry air saturated by gasoline vapor slowly displaces (several hundred $\text{cm}^3/\text{minute}$) the dry air in a 13.7 liter volume optical cell (4 meter path length). Figure 14 shows the sensor response as the vapor concentration approaches and exceeds the lower explosive limit (LEL) for most hydrocarbon vapors

(e.g., for JP-8 and most other middle distillate fuels the LEL is approximately 10000 ppm [24,29]). For the absorbance measurement, the background for each laser was the demodulated signal prior to the onset of fuel vapor flow. The flow apparatus was characterized using our first generation sensor, and using that calibration the absorbance reported here is reasonably linear with concentration (within 5%), but was not explicitly measured for these experiments. All of the factors that determine quality of conventionally measured FT-IR spectra are of importance here (modulation depth, apodization, phase, etc. [28]). Most of the efforts for the prototype were focused on making sure the lasers were modulated in phase, using a common timebase. We did not investigate effects of varying the modulation depth or of varying the laser power. Dynamic range effects were not investigated, although we anticipate some improvement relative to Michelson interferometer based instruments because the Fourier frequencies for each laser are no longer coupled to the laser wavelength. Time for each measurement point was approximately one second. All measurements were made at atmospheric pressure.

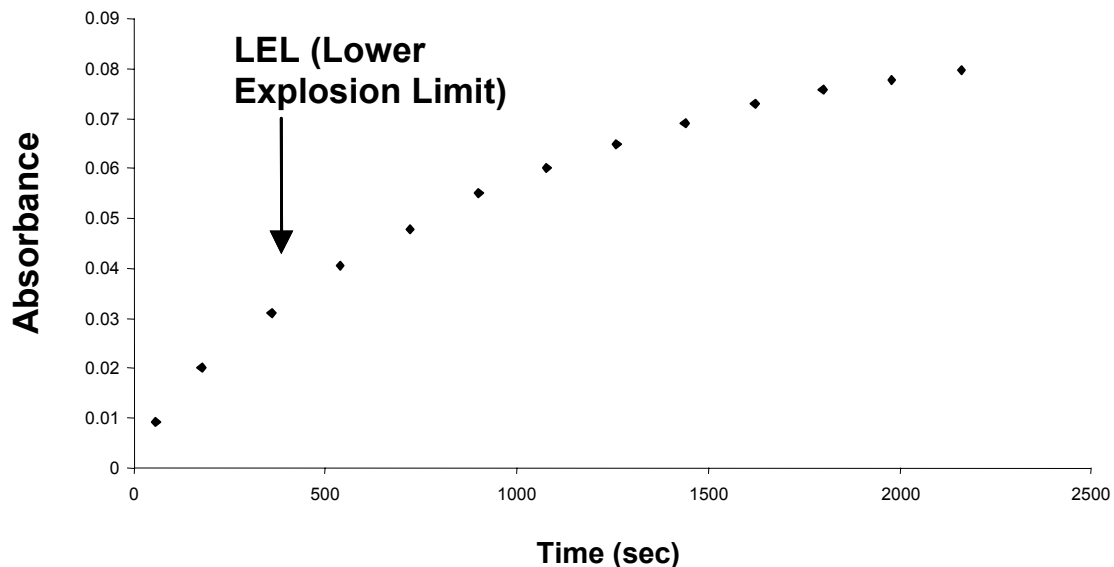

Figure 14: Absorption of laser radiation at 1.71 micrometers as air in 2m cell is displaced by air saturated with gasoline vapor. For the absorbance calculation, the background was the demodulated signal for each laser prior to the onset of fuel vapor flow.

ii. Sensitivity

The absorption coefficients for most VOC's in the near-infrared spectral region (~1 to 2 micrometer wavelength, two (or more) vibrational quanta per transition) are

typically lower by an order of magnitude than for the mid-infrared spectral region (~2-30 micrometer wavelength, typically 1 vibrational quantum per transition) [32]. In our lab we have measured the near infrared absorption coefficients between wavelengths of 1.0 and 30 micrometers for several VOC's (see Figure 7). For the military fuel JP-8 (a mixture of several hundred hydrocarbons) we have measured [using a Bomem DA-8 FT-IR spectrometer] the maximum absorption coefficient in the spectral region between a wavelength of 1.6 and 1.825 micrometers to be approximately 3×10^{-21} cm²/molecule [4]. Using the prototype FT-LS instrument described above [33] we obtained a detection limit of approximately 200 ppm-m (parts per million per meter path) for JP-8 vapor in air, or approximately 50 times worse than the detection limit using a commercial FT-IR spectrometer. It is worth noting that for the prototype sensor described here, we observed that the power modulation of each diode laser was not purely cosinusoidal (harmonics in the FFT output), even though the driver current was supplied by the SRS DG535 function generators. We anticipate that as the number of lasers being power modulated is increased, the contributions to signal from frequencies other than driver frequencies may limit resolution. We have considered designing a custom driver waveform to give the best cosinusoidal power modulation, but have yet to actually try this.

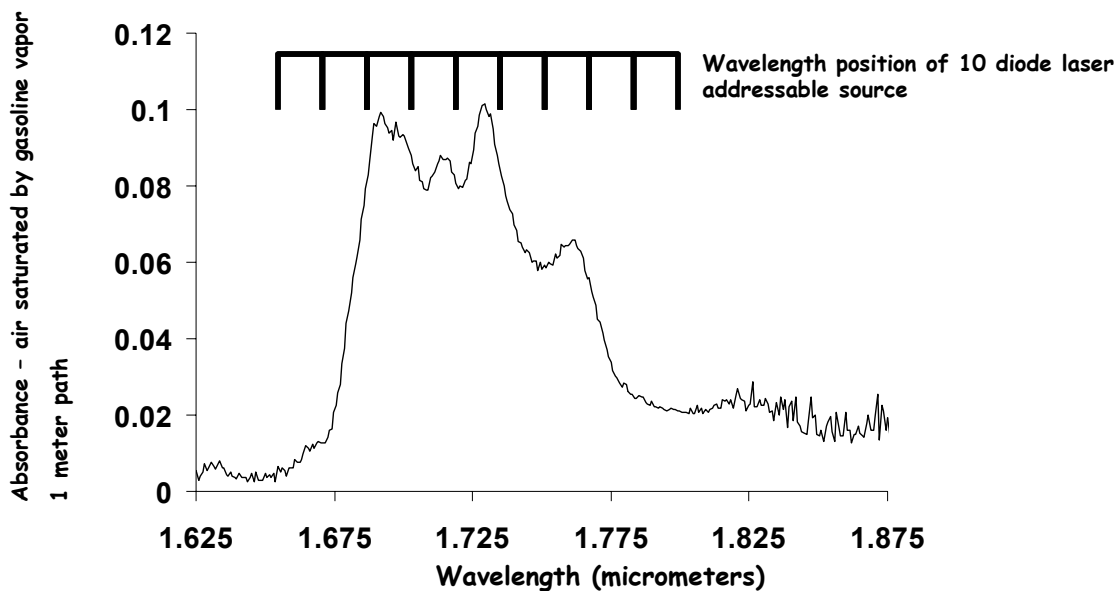

Figure 15: Schematic of a 10-laser FT-LS source in the near infrared (under development), providing reasonable coverage of the full overtone C-H absorption envelope for hydrocarbon vapors.

iii. Future Developments

We are presently pursuing development of a 10-laser FT-LS source in the near infrared, providing reasonable coverage of the full overtone C-H absorption envelope for hydrocarbon vapors. The basic idea for this sensor is illustrated in Figure 15. Analysis similar to PLS techniques already employed for FT-IR spectral data could be used to identify mixture components [34]. Such an instrument may be readily assembled from

commercially available tel-com equipment. Here, the main impediment is finding a vendor for the individual laser diodes. The problem is that low demand for lasers outside of the fiber windows near 1350 nm and 1550 nm limits availability.

Provided that the cost of addressable light sources continues to decrease, arrays covering larger spectral windows may become available. While several options exist for wavelength separation, we believe that the highly developed FT-IR market may influence the design of new solid state spectrometers, and that this approach may warrant further consideration.

f. Technical Problems

The main technical difficulties associated with this project center on the availability of DFB lasers. With the contraction of the tel-com market at the beginning of this century, many fabrication facilities discontinued manufacture of lasers at user specified wavelengths, producing lasers only within the tel-com bands near 1330 nm and 1550 nm. Although some of the decrease in availability of domestically manufactured near-infrared DFB lasers has been made up by foreign manufacturers (in particular, NEC of Japan), obtaining lasers for gas sensing (in particular, O₂ near 760 nm) remains challenging. The difficulty in obtaining lasers at custom wavelengths exacerbates what we perceive to be the main challenge for gas sensing using near infrared DFB lasers – namely, sensing of molecules and mixtures of gases that do not present well resolved vibrational spectra. We believe we have made reasonable efforts towards solving this problem (see sections 3d and 3e above), but the difficulty in obtaining lasers at custom wavelengths makes full demonstration of a truly addressable source difficult.

g. Recommendations and Conclusion

Gas sensing using near-infrared lasers will probably continue gaining market share, although it seems likely that a transition will occur in which a single laser detecting a single gas is replaced either by an addressable source, or by a single, broadly tunable laser. Near infrared devices for gas sensing will likely continue to be used because of the ease of transmission through optical fibers, room temperature operation, high signal to noise ratio through phase sensitive detection techniques, and because of the large tel-com infrastructure that continues development of electronics that may easily be adapted to gas sensing. However, room temperature operation mid-infrared lasers (quantum cascade and interband cascade designs) offer all of the advantages of phase sensitive detection available with near-infrared DFB's, with the huge advantage of gas sensing using the fundamental vibrational transition. It seems likely that future microphotonic sensors will employ suites of arrays of near- and mid-infrared devices, and that these devices will gradually displace conventional Michelson interferometer based systems in the laboratory and in the field.

4. References

- [1] J. Reid and D. Labrie, "Second-Harmonic Detection with Tunable Diode Lasers - Comparison of Experiment and Theory", *Appl. Physics*, **B 26**, pp. 203-210, (1981).
- [2] D.S. Bomse, A.C. Stanton, and J.A. Silver, "Frequency modulation and wavelength modulation spectroscopies: comparison of experimental methods using a lead-salt diode laser", *Appl. Optics*, Vol. 31, 718-731 (1992).
- [3] P.C.D. Hobbs, "Ultrasensitive laser measurements without tears", *Appl. Optics*, Vol. 36, pp. 903-21, (1997).
- [4] I. Linnerud, P. Kaspersen, and T. Jaeger, "Gas monitoring in the process industry using diode laser spectroscopy", *Applied Physics B*, Vol. 67, pp. 297-305, (1998).
- [5] R. Martinelli, R. Menna, D. Cooper, C. Carlisle, H. Riris, "Near-infrared InGaAs/InP distributed-feedback lasers for spectroscopic applications", *Proc. SPIE Vol. 2148*, p292-307, *Laser Diode Technology and Applications VI*, P.C. Chen, L.A. Johnson, H. Temkin; Eds. (1994).
- [6] K.L. McNesby, R.T. Wainner, R.G. Daniel, R. R. Skaggs, J. B. Morris, A.W. Miziolek, W.M. Jackson, I.A. McLaren, "Detection and Measurement of Middle-Distillate Fuel Vapors by Use of Tunable Diode Lasers", *Applied Optics*, Vol. 40, pp. 840-845 (2001).
- [7] Lancaster, E.D., McNesby, K.L., Daniel, R.G., Miziolek, A.W., "Spectroscopic Analysis of Fire Suppressants and Refrigerants by Laser Induced Breakdown Spectroscopy", *Applied Optics*, Vol. 38, p1476 (1999).
- [8] Williamson, C.K., McNesby, K.L., Daniel, R.G., and Miziolek, A.W., "Laser-Induced Breakdown Spectroscopy for Real-Time Detection of Halon Alternative Agents," *Analytical Chemistry* **70**, 1186-1191, (1998).
- [9] M.Q. Brewster, *Thermal Radiative Transfer and Properties*, Wiley Interscience, New York (1992), p. 253.
- [10] K.L. McNesby, R.R. Skaggs, A.W. Miziolek, M. Clay, S. Hoke, and C.S. Miser, "Diode Laser-Based Measurements Of Hydrogen Fluoride Gas During Chemical Suppression Of Fires" *Applied Physics B*, Vol. 67, p443, (1998).
- [11] K.L. McNesby, R.G. Daniel, S.H. Modiano, A.W. Miziolek, *Optical Measurement of Toxic Gases Produced During Firefighting Using Halons*, *Applied Spectroscopy*, vol. 51, pp. 678-683, 1997.

- [12] K.L. McNesby, R.G. Daniel, A.W. Miziolek, and S.H. Modiano, "Optical Measurement of Toxic Gases Produced During Firefighting Using Halons", ARL-TR-1349, April 1997.
- [13] McNesby, K.L., Skaggs, R.R., Miziolek, A.W., Daniel, R.G., and Miser, C.S., "Near-Infrared Tunable Laser Diagnostics In Laboratory Scale Flames," *Proceedings of Laser Applications To Chemical and Environmental Analysis Topical Meeting*, p. 203, 1998.
- [14] McNesby, K.L., Skaggs, R.R., Miziolek, A.W., Clay, M., Hoke, S., and Miser, C.S., "Diode Laser-Based Measurements Of Hydrogen Fluoride Gas During Chemical Suppression Of Fires," *ARL-TR -1785*, 1998.
- [15] Skaggs, R.R., Daniel, R.G., Miziolek, A.W., McNesby, K.L., Herud, C., Bolt, W.R., and Horton, D., "Diode Laser Measurements of HF Concentrations from Heptane/Air Pan Fires Extinguished by FE-36 And FE-36 Plus Ammonium Polyphosphate," ARL-TR, submitted 1998.
- [16] Skaggs, R.R., Daniel, R.G., Miziolek, A.W., McNesby, K.L., Herud, C., Bolt, W.R., and Horton, D., "Diode Laser Measurements Of HF Concentrations Produced from Heptane/Air Pan Fires Extinguished By FE-36, FM-200, FE-36 Plus APP, or FM-200 Plus APP," *Proceedings of the 1998 JANNAF Combustion Meeting*, CPIA Publication 685, p.161, 2000.
- [17] Skaggs, R.R., Daniel, R.G., Miziolek, A.W., McNesby, K.L., Herud, C., Bolt, W.R., and Horton, D., "Diode Laser Measurements Of HF Concentrations Produced From Heptane/Air Pan Fires Extinguished By FE-36, FM-200, FE-36 Plus APP, Or FM-200 Plus APP," *Applied Spectroscopy*, Vol. 53, p. 1143 (1999).
- [18] Skaggs, R.R., Daniel, R.G., Miziolek, A.W., McNesby, K.L., Herud, C. Bolt, W.R., and Horton D., "Diode Laser Measurements of HF Concentrations From Heptane/Air Pan Fires Extinguished by FE-36 And FE-36 Plus Ammonium Polyphosphate," *1998 Proceedings of the International Society for Optical Engineering: Photonics East*, in press, 1999.
- [19] *Infrared Methods for Gaseous Measurements - Theory and Practice*, J. Wormhoudt, Ed., Marcel-Dekker, New York, 1985;
- [20] Guenther P.L.; Stedman D.H.; Bishop G.A.; Beaton S.P.; Bean J.H.; Quine R.W., " A hydrocarbon detector for the remote sensing of vehicle exhaust emissions", *Review of Scientific Instruments*, Vol. 66, pp. 3024-3029 (1995)
- [21] <http://www.brandtinst.com/biosystems/appnotes/equiv3.htm>
- [22] S.H. Modiano, K.L. McNesby, P.E. Marsh, W. Bolt and C. Herud, "Quantitative measurements by Fourier transform infrared spectroscopy of toxic gas production during inhibition of JP-8 fires by CF₃Br and C₃F₇H", *Appl. Optics*, Vol. 35, pp. 4004-4008 (1996).

- [23] P.R. Griffiths, B.L. Hirsche, and C.J. Manning, "Ultra-rapid-scanning Fourier transform infrared spectrometry", *Vib. Spectroscopy*, Vol. 19, pp.165-176 (1999).
- [24] D.W. Naegeli and K.H. Childress, "Lower Explosion Limits and Compositions of Middle Distillate Fuel Vapors", *Proceedings of the Fall Meeting of the Society of Automotive Engineers*, SAE paper # 982485, (1998), pp. 1-7; also see Kuchta, J. M. and R. G. Clodfelter, "Aircraft mishap fire pattern investigations. Final Report" APWAL-TR-85-2057, Aero Propulsion Laboratory, (1985); M. R. Baer and R. J. Gross, "Extended Modeling Studies of the TWA 800 Center-Wing Fuel Tank Explosion", Sandia National Laboratories Report SAND2000-0445. 44 pp., March 2000.; J. Shepherd, "Learning from a Tragedy: Explosions and Flight 800", *Engineering and Science*, No. 2, pp. 18-29, 1998.
- [25] P. Werle, "A review of recent advances in semiconductor laser based gas monitors", *Spectrochimica Acta Part A*, Vol. 54, pp.197-236 (1998).
- [26] G. Hertzberg, *Infrared and Raman Spectra*, Van Nostrand Rheinhold Co., New York, 1945.
- [27] K.L. McNesby, R.T. Wainner, R.G. Daniel, A.W. Miziolek, W.M. Jackson, I.A. McLaren "High-Sensitivity Laser Absorption Measurements of Broadband Absorbers in the Near-Infrared Spectral Region" *Applied Optics*, Vol. 39, pp. 5006-5011, (2000).
- [28] P.R. Griffiths and J.A. de Haseth, *Fourier Transform Infrared Spectrometry*, Wiley-Interscience, New York, 1986.
- [29] K.L. McNesby, R.T. Wainner, R.G. Daniel, R.R. Skaggs, J.B. Morris, A.W. Miziolek, W. M. Jackson, I.A. McLaren "Detection and Measurement of Middle-Distillate Fuel Vapors by Use of Tunable Diode Lasers" *Applied Optics*, Vol. 40, pp. 840-845, (2001).
- [30] J.R. Ferraro and L.J. Basile, *Fourier Transform Infrared Spectroscopy : Applications to Chemical Systems*", Vols. 1-3, Academic Press, New York, 1978; also see Ref. 29.
- [31] J.W. Cooley and J.W. Tukey, "An Algorithm for the Machine Calculation of Complex Fourier Series", *Math. Comput.*, Vol. 19, p. 297 (1965).
- [32] L.S. Rothman, R.R. Gamache, R.H. Tipping, C.P. Rinsland, M.A.H. Smith, D. Chris, V. Benner, M. Devi, J.-M Flaud, C. Camy-Peyret, A. Perrin, A. Goldman, S.T. Massie, L.R. Brown, R.A. Toth, "The Hitran Molecular Database: Editions of 1991 and 1992", *J. Quant. Spectrosc. Radiat. Transfer*, Vol. 48, p. 469, (1992).

[33] K.L. McNesby and A.W. Miziolek, "Fourier Transform Laser Spectroscopy", accepted for publication in *Applied Optics*.

[34] Xiang Zhu, Daniel T. Cassidy, "Liquid detection with InGaAsP semiconductor lasers having multiple short external cavities", *Applied Optics-LP*, Volume 35, Issue 24, 4689-4693 (1996).

5. Publications

K.L. McNesby, R.G. Daniel, A.W. Miziolek, and S.H. Modiano, "Optical Measurement of Toxic Gases Produced During Firefighting Using Halons", ARL-TR-1349, April 1997.

K.L. McNesby, R.G. Daniel, S.H. Modiano, A.W. Miziolek, Optical Measurement of Toxic Gases Produced During Firefighting Using Halons, *Applied Spectroscopy*, vol. 51, pp. 678-683, 1997.

R.G. Daniel, K. L. McNesby, R.R. Skaggs, P. Sagar, and A.W. Miziolek, "Spectroscopy of Inhibited Counterflow Diffusion Flames", 1997 JANNAF Propellant Development & Characterization Subcommittee Meeting, West Palm Beach, FL.

K.L. McNesby, R.R. Skaggs, A.W. Miziolek, M. Clay, S. Hoke, and C.S. Miser, "Diode Laser-Based Measurements Of Hydrogen Fluoride Gas During Chemical Suppression Of Fires" *Applied Physics B*, Vol. 67, p443, (1998).

Williamson, C.K., McNesby, K.L., Daniel, R.G., and Miziolek, A.W., "Laser-Induced Breakdown Spectroscopy for Real-Time Detection of Halon Alternative Agents," *Analytical Chemistry* **70**, 1186-1191, (1998).

McNesby, K.L., Skaggs, R.R., Miziolek, A.W., Daniel, R.G., and Miser, C.S., "Near-Infrared Tunable Laser Diagnostics In Laboratory Scale Flames," *Proceedings of Laser Applications To Chemical and Environmental Analysis Topical Meeting*, p. 203, 1998.

McNesby, K.L., Skaggs, R.R., Miziolek, A.W., Clay, M., Hoke, S., and Miser, C.S., "Diode Laser-Based Measurements Of Hydrogen Fluoride Gas During Chemical Suppression Of Fires," *ARL-TR -1785*, 1998.

Skaggs, R.R., Daniel, R.G., Miziolek, A.W., McNesby, K.L., Herud, C., Bolt, W.R., and Horton, D., "Diode Laser Measurements of HF Concentrations from Heptane/Air Pan Fires Extinguished by FE-36 And FE-36 Plus Ammonium Polyphosphate," ARL-TR.

Skaggs, R.R., Daniel, R.G., Miziolek, A.W., McNesby, K.L., Herud, C., Bolt, W.R., and Horton, D., "Diode Laser Measurements Of HF Concentrations Produced from Heptane/Air Pan Fires Extinguished By FE-36, FM-200, FE-36 Plus APP, or FM-200 Plus APP," *Proceedings of the 1998 JANNAF Combustion Meeting*, CPIA Publication 685, p.161, 2000.

Skaggs, R.R., Daniel, R.G., Miziolek, A.W., McNesby, K.L., Herud, C., Bolt, W.R., and Horton, D., "Diode Laser Measurements Of HF Concentrations Produced From Heptane/Air Pan Fires Extinguished By FE-36, FM-200, FE-36 Plus APP, Or FM-200 Plus APP," *Applied Spectroscopy*, Vol. 53, p. 1143 (1999).

Lancaster, E.D., McNesby, K.L., Daniel, R.G., Miziolek, A.W., "Spectroscopic Analysis of Fire Suppressants and Refrigerants by Laser Induced Breakdown Spectroscopy", *Applied Optics*, Vol. 38, p1476 (1999).

Skaggs, R.R., Daniel, R.G., Miziolek, A.W., McNesby, K.L., Herud, C. Bolt, W.R., and Horton D., "Diode Laser Measurements of HF Concentrations From Heptane/Air Pan Fires Extinguished by FE-36 And FE-36 Plus Ammonium Polyphosphate," *1998 Proceedings of the International Society for Optical Engineering: Photonics East*, 1999.

McNesby, K.L., Skaggs, R.R., Miziolek, A.W., and McLaren, I.A., "Diode Laser-Based Detector for Fast Detection of Binary Gas Mixtures," *Proceedings of the 1999 Halon Options Technical Working Conference, Albuquerque, 1999*.

McNesby, K.L., Wainner, R.T., Miziolek, A.W., Jackson, W.M., McLaren, I.A., "High Sensitivity Laser Absorption Measurements of Broad Band Absorbers in the Near-Infrared Spectral Region", *Applied Optics-LP*, Volume 39, Issue 27, 5006-5011 September 2000.

McNesby, K.L., Miziolek, McLaren I.A., "Rapid High Sensitivity Laser Absorption Measurements of Broad Band Absorbers in the Near Infrared Spectral Region," *Proceedings of Laser Applications To Chemical and Environmental Analysis Topical Meeting*, p. 80, 2000.

K.L. McNesby, R.T. Wainner, R.G. Daniel, R.R. Skaggs, J.B. Morris, A.W. Miziolek, W.M. Jackson, and I.A. McLaren, "Detection and measurement of middle distillate fuel vapors using tunable diode lasers", *Applied Optics*, Vol. 40, pp. 840-845 (2001).

K.L. McNesby, A.W. Miziolek, and I.A. McLaren, "Rapid high sensitivity laser absorption measurements of broad band absorbers in the near infrared spectral region" in *Laser Applications to Chemical and Environmental Analysis*, OSA (Optical Society of America) Technical Digest, pp. 80-83 (2000)

A.W. Miziolek, K.L. McNesby, R.T. Wainner, R.S. Harmon, P.D. French, "LIBS: An emerging chemical sensor technology for field use in warfare and peacetime applications", 2000 Army Science conference.

K.L. McNesby, R.G. Daniel, A.W. Miziolek, R.T. Wainner, W.M. Jackson, I.A. McLaren, "Measurement of middle distillate fuel vapor concentrations using diode laser spectroscopy", *Proceedings of Halon Options Technical Working Conference (HOTWC)*, May, 2000.

K.L. McNesby, "Flame and Temperature Measurement Using Vibrational Spectroscopy", Encyclopedia of Spectroscopy and Spectrometry, pp. 548 to 559 (Academic Press, London, 2000).

K.L. McNesby and A.W. Miziolek, "Fourier Transform Laser Spectroscopy", accepted for publication in *Applied Optics*, July, 2000.

6. Milestones

FY 97 Milestones

1. Complete comparison of LIBS vs near-ir lasers for oxygen detection.

Status: Met

2. Evaluate LIBS for P, Si, -NH_x, and metal-containing suppressants, as well as other new fire suppression chemicals of tri-service interest.

Status: Met

3. Procure near-ir lasers for two additional gases.

Status: Met

4. Complete installation of additional near-ir lasers at ATC.

Status: Met

5. Complete transition of LIBS sensor technology from ARL to ATC.

Status: Unmet. After testing of LIBS for characterization of suppressants, fuels, and oxidizers, it was found that current fiber coupled laser systems did not meet sufficient durability requirements for transmission of laser radiation necessary for air breakdown (approximately 100 mJ/pulse, 10 nsec pulse length).

FY 98-99 Milestones

1. Measurement of near infrared absorption survey spectra (using a FT-NIR spectrometer) of heptane and JP-8 at several temperatures.

Status: Met

2. Procurement of laser diodes whose output wavelength is coincident with an absorption transition in these gases as determined by the survey spectra.

Status: Met

3. Procurement of fiber signal splitters, GRIN lens-tipped fibers, and InGaAs detectors for multipoint detection.

Status: Met

4. Procurement of additional lasers and equipment for multiplexing applications and for multipoint measurements.

Status: Met

5. Procurement of additional fibers for multiple point LIBS.

Status: Unmet. Suitable fibers for transmission of pulsed laser radiation were unavailable.

6. Complete evaluation of demodulation techniques for multiplex TDLAS.

Status: Partially met. Modulation techniques for measurement of gases with unstructured absorption spectra became a main focus of this project. The work performed in this area resulted in three publications (see sections 3d and 3e of this document), although the authors believe the effort at measuring broad band absorbers has not been suitably concluded.

7. Software development for multiplex spectral measurement, demodulation, and real time display of concentrations of fuel and oxidizer.

Status: Partially met. See milestone 6 above. Real time display used commercial software (LabView), employing custom VI interface programs.

8. Procurement of demodulation electronics. Demonstration of continuous 10 ms time resolution, data storage capabilities.

Status: met

9. Laboratory calibration of diode laser 2f spectra for O₂, heptane, and JP-8.

Status: Partially met. Oxygen calibration was straightforward, and was referenced against an Oxygraph oxygen meter. Middle distillates and heptane were measured using the "broadband absorber" techniques described in sections 3d and 3e of this document.

10. Initial testing of the fuel/oxygen sensor on static heptane/air and JP-8/air mixtures. Comparison testing against the NIST "phi meter".

Status: Partially met. JP-8/air mixtures were successfully measured in lab. Comparison testing with NIST phi-meter was never performed.

11. Extension of initial sensor to multipoint detection capability.

Status: Unmet. Use of the splitter required for multipoint detection caused the mixed laser beam to lose modulation balance. We were not able to correct this within the project duration.

12. Complete initial multipoint measurements of fuel/oxidizer mixtures (laboratory based) for determination of flammable mixture detection.

Status: Partially met. Single point detection successful. Use of the splitter required for multipoint detection caused the mixed laser beam to lose modulation balance. We were not able to correct this within the project duration.

13. Initial fuel/oxygen sensor installation, testing at ATC facility. Initial LIBS installation, testing at ATC facility.

Status: Partially met. Initial fuel/air testing at ATC successful for single point measurement. Multipoint installation failed because splitter required for multipoint detection caused the mixed laser beam to lose modulation balance. We were not able to correct this within the project duration.

14. Initial field testing of LIBS for multipoint measurement of halon alternative compounds. Comparison with DIRRACS method.

Status: Unmet. Suitable fibers for transmission of pulsed laser radiation were unavailable.

15. Demonstration of multiplex detection of fuel/oxygen mixtures during real scale fire suppression testing.

Status: Partially met. Single point detection only.

16. Demonstration of LIBS for multiple point detection of FM-200 in crew compartment.

Status: Unmet. Suitable fibers for transmission of pulsed laser radiation were unavailable.

7. Significant Project Results – Discussion and Recommendations

We believe this project to have been successful, although the achieved results differed appreciably from those outlined in the initial proposals. The project fell short of initial expectations in that diode lasers are currently fielded at ATC (Aberdeen Test Center) only for HF and oxygen measurement. Real time fuel measurement, demonstrated successfully in the laboratory at the ARL (Army Research Laboratory), has not been successfully transitioned to ATC. The reasons for this are twofold. First, although we developed two methods for laser based measurements of “broadband absorbers” (gases with poorly resolved vibrational structure), we have been unable to achieve sensitivities for these gases similar to those attainable for detection of light hydrocarbons, e.g., methane. Additionally, for multipoint detection we were unable to maintain the modulation balance on which our first technique was dependent. We are still engaged in refining our techniques for measuring gases that do not exhibit well resolved vibrational structure. Second, measurement of these heavy hydrocarbon vapors requires near-infrared DFB lasers near a wavelength of 1.7 micrometers. These lasers must be custom fabricated. For such custom orders, it is necessary to wait until several customers need lasers in this wavelength region, making the wafer growth economically feasible.

Laser induced breakdown spectroscopy (LIBS) has never been transitioned to field use within armored vehicles at ATC. The main reason for this is that optical fibers necessary for delivering pulsed radiation to the measurement site were found to be unreliable (failure at less than 200 shots). It’s worth noting that several manufacturers are now offering fibers for delivering pulsed radiation at 1.06 micrometers. The current highest power delivery fiber of which we are aware (3M, “Powercore” fibers, up to 80 mJ/pulse at 10 nsec) may enable LIBS of gases at remote locations.

Given these shortcomings, we still believe the project to be successful. First, we demonstrated the first measurement of “broadband absorbers” using phase sensitive detection. Additionally, the project resulted in development of Fourier transform laser spectroscopy, in which an array of lasers are used to create an addressable source that mimics the output of a Michelson interferometer, but with no moving parts, and with the Fourier frequencies decoupled from the light wavelengths. Secondly, and perhaps even more important, the project has demonstrated the use of laser induced breakdown spectroscopy (LIBS) for quantitative measurement of gases. The use of LIBS for this project provided much impetus for expanding this technique into investigations of detection methods for toxic and explosive materials, including chem./bio agents.

Thirdly, the project has resulted in a greater understanding of toxic gas formation (specifically HF gas) during fire suppression onboard armored vehicles. The combination of diode laser measurements and of extractive FT-IR measurements during real scale testing has lent credence to both methods. Tunable diode laser measurements have shown how the rate of formation of HF gas is affected by varying fire suppressants, and by chemicals added to decrease HF formation.

8. Conclusion

We believe microphotonic sensors, employing TDL spectroscopy and LIBS, will play a major role in the next generation of sensor equipment. Equipment design and experimental results from this project have enhanced the effort towards this next generation of sensors. We hope to continue our work in TDL spectroscopy and LIBS, and to continue development of sensors of use to the Army.