

UNITED STATES DEPARTMENT OF COMMERCE • Charles Sawyer, Secretary
NATIONAL BUREAU OF STANDARDS • E. U. Condon, Director

Precision Resistors and Their Measurement

by James L. Thomas



National Bureau of Standards Circular 470

Issued October 8, 1948

Available from the Superintendent of Documents, U. S. Government Printing Office, Washington 25, D. C.
Price 20 cents

Preface

There are few fields of scientific investigation in which accurate measurements of electrical resistance are not required. For this purpose the Wheatstone bridge, in one of its several forms, is almost universally used. This instrument is comparatively simple to use and at the same time has a very high sensitivity. Unfortunately, however, sensitivity and accuracy are not synonymous, and some knowledge of the practical limitations of resistance-measuring bridges is needed by all users. This circular is intended to supply such information. Although the presentation is essentially nontechnical, it is believed that the subject matter will be of value to any one interested in the accurate measurement of resistance.

In addition to information about the use of resistance bridges, this circular presents methods for their calibration. The subject matter is limited to direct-current calibrations, and the methods discussed are those regularly used at this Bureau when an accuracy of 0.01 percent or better is required. No attempt is made to present a complete discussion of methods of resistance measurement or to consider the relative merits of various methods. Those presented are comparatively simple, being based largely on substitution procedures, yet they are capable of yielding results of high accuracy.

E. U. CONDON, *Director.*

Contents

	Page
Preface.....	ii
I. Introduction.....	1
1. Definition of resistance.....	1
2. Importance of resistance measurements.....	1
3. Types of resistors.....	2
II. Resistance Materials and Construction Methods.....	2
1. Resistance alloys.....	2
2. Spools, winding and adjustment.....	4
3. Sheet-metal resistors.....	5
4. Accelerated aging.....	6
5. Annealed resistors.....	6
6. Effects of humidity.....	7
7. Load coefficients.....	9
8. Stability of resistors with time.....	9
III. Methods of Comparison of Resistors.....	10
1. Ammeter-voltmeter methods.....	10
2. Ohmmeters.....	11
3. Potentiometer method.....	11
4. Differential-galvanometer method.....	12
5. Bridge methods.....	13
IV. Special Apparatus for Precision Measurements.....	19
1. Direct-reading ratio set.....	19
2. Universal ratio set.....	26
V. Calibration of Precision Bridges.....	28
1. Calibration of Wheatstone bridges.....	28
2. Calibration of thermometer bridges.....	29
VI. Resistivity of Solid Conductors.....	31
1. Resistivity, definition and units.....	31
2. Measurement of resistivity.....	31
VII. References.....	32

Precision Resistors and Their Measurement

By James L. Thomas

Abstract

This circular contains information on the construction and characteristics of wire-wound resistors of the precision type. There are also included descriptions of the methods used at this Bureau for the test of precision resistors and the calibration of precision resistance measuring apparatus. Although the presentation is nontechnical, there is a considerable amount of information on the characteristics and limitations of apparatus of this type that should be of interest to any one making accurate measurements of electrical resistance.

I. Introduction

1. Definition of Resistance

The modern concept of electrical resistance is based largely on the work of G. S. Ohm, who in 1826 published an equation that was formulated on the basis of his experiments with direct-current circuits. In modern terminology this equation is

$$I = \gamma \frac{A}{l} E, \quad (1)$$

where E is the potential difference across a conductor of length l and cross-sectional area A when a current, I , flows. The factor γ depends upon the material of the conductor and is now called conductivity (see sec. VI). The above equation was abbreviated by Ohm as

$$I = \frac{E}{\mathcal{L}}, \quad (2)$$

where \mathcal{L} is the length of a hypothetical wire having unit conductivity and cross-sectional area. \mathcal{L} was then the length of a wire across which unit current would produce a unit of potential difference, that is, \mathcal{L} was Ohm's unit of resistance and his experimental equation can be abbreviated as

$$E = RI. \quad (3)$$

This equation is almost universally referred to as Ohm's Law, although some writers contend that the longer form should be so designated. Although experimentally determined for individual conductors, Ohm's Law was soon applied to the entire circuit if E designates the net electromotive force in the circuit.

2. Importance of Resistance Measurements

Although Ohm found that the ratio of potential difference across a conductor to the current flow-

ing in it is dependent on the material and dimensions of the conductor, more precise experiments showed it to depend upon temperature and even upon the presence of stress in the conductor. Instead of incorporating such quantities in our equation for the current, we say that the resistance is a function of temperature and stress, and for a given conductor we must state the values of temperature and stress for which a value of resistance is given.

The fact that resistance is a function of temperature is made use of in temperature measurements, the resistance of a wire being measured at known temperatures or fixed points and then at the unknown temperatures. Also, changes in resistance with dimensions are utilized for measuring small displacements, and change in resistance with stress is utilized for the measurement of liquid pressures. In addition to such phenomena, a large number of physical and chemical phenomena are investigated by means of measurements of electromotive forces, and the measurement of electromotive force is customarily carried out by measurements of resistance ratios. Electric current is readily measured in terms of the potential difference across a known resistor. In fact, a large proportion of electrical quantities is measured by methods that involve the measurement of resistance.

In some cases the resistance of a conductor depends upon the magnitude of the current flowing through it. That is to say, Ohm's law is not applicable, and the resistance must be determined under the conditions of use. Also, the resistance of all conductors is to some extent a function of frequency, and the resistance must often be determined in such a way as to allow for the effect of frequency. However, the content of this circular is limited largely to direct-current measurements of resistors which follow Ohm's law, with special emphasis on precision measurements, i. e., measurements to 0.01 percent or better.

3. Types of Resistors

Resistors are used for many purposes with a correspondingly large range of types and accuracies of adjustment. They are used as electric heaters, as current-limiting devices such as motor starters, for component parts of radio, telephonic and similar equipment, and in electrical instruments of greater or less precision. For some applications adjustments must be made to perhaps 10 to 20 percent, whereas in others the resistors must be within 0.01 percent or less of their nominal values.

For use as heaters, resistors are usually made of special alloy wire that will withstand high temperatures for long periods of heating. The most used alloy for this purpose is of nickel and chromium, with or without the addition of a considerable amount of iron. These alloys can be kept at a "red heat" in air for long periods of time without damage from oxidation. High-resistance units for radio circuits are often made from a nonconducting binder, such as clay, with which is mixed sufficient powdered graphite to make the material slightly conducting; or from a nonconducting rod on the surface of which is deposited a conducting film. For resistors to be used in precision instruments the important quality desired is stability with time and temperature, and special alloys have been developed, which are discussed in section II.

II. Resistance Materials and Construction Methods

1. Resistance Alloys

Manganin. Since their introduction in about 1890, alloys of copper, manganese, and nickel have come into almost universal use as resistance materials for precision resistors and for resistance measuring apparatus. The most common of these alloys is "manganin" which has the nominal proportions of 84 percent of copper, 12 percent of manganese and 4 percent of nickel. This material has a resistivity of 45 to 50 microhm-cm, a thermoelectromotive force against copper of 2 or 3 $\mu\text{V}/^\circ\text{C}$., and, when properly heat treated, is very stable in resistance with time.

The electrical properties of alloys of copper, manganese, and nickel over a large range of proportions were investigated in 1925 by Pilling [1]¹ and later for alloys made of high-purity ingredients by Dean and Anderson [2]. Both of these investigations showed that an alloy having a temperature coefficient that averaged zero over the interval 0 to 100° C. would be obtained with approximately 10 percent each of manganese and nickel, the remainder being copper. A series of alloys also having zero temperature coefficients could be obtained by increasing separately either the manganese or the nickel up to as much as

Stability with time and temperature are also the important characteristics required for resistors that are to be used as reference standards for the calibration of other resistors.

Standard resistors are usually commercially available only in decimal multiples or fractions of the unit, usually from 0.0001 ohm to 10,000 ohms. These are of two general types of construction, either two-terminal or four-terminal types. For values of resistance where the resistance of the contacts, made in connecting to the resistor, is not negligible, it is customary to use four-terminal resistors. Whether or not the contact resistances are negligible depends upon the accuracy desired, but in general standard resistors of 1-ohm and less are of the four-terminal type, higher valued resistors needing only two terminals. Special standard resistors are required if an accuracy of better than 0.01 percent is required. These are usually sealed to protect the resistors from the effects of oxygen and moisture in the atmosphere, whereas resistors for an accuracy of 0.1 percent do not require such protection. Although precision resistors are ordinarily adjusted to their nominal values to 0.01 percent or better, they gradually change in resistance with time. For work to this accuracy it is desirable to have standards recalibrated occasionally, applying if necessary corrections corresponding to their departure from nominal values.

20 or 30 percent, with a corresponding reduction in copper.

On the basis of small temperature coefficients there would appear to be a wide choice of compositions for alloys of the manganin type. However, in order to keep the thermoelectric power against copper as low as possible it is necessary to keep the nickel content low, as the thermoelectric power increases rapidly in proportion to the amount of nickel above 2 or 3 percent. Also, if the nickel is kept constant and the percentage of manganese is increased the curvature of the resistance-temperature curve increases. This means that although the resistance might have the same value at 0° and 100° C., the departure from this value at intermediate temperatures increases with the manganese content. It is therefore desirable for general use to have an alloy that is as low as possible in both nickel and manganese.

The published data on copper-manganese-nickel alloys give average temperature coefficients over a temperature interval of some 80 to 100° C. These data do not show the best compositions for use at ordinary laboratory temperatures. If it is desired to keep the thermoelectric power against copper as small as possible, the alloy should have a content of about 2 percent of nickel and 14 percent of manganese in order to obtain at the

¹ Figures in brackets indicate the literature references at the end of this paper.

same time a small temperature coefficient of resistance at ordinary room temperatures. On the other hand, if the thermoelectric power is of no importance the resistance of an alloy of about 20 percent of nickel and 10 percent of manganese would be most constant with temperature in the ordinary range of laboratory temperatures. The accepted composition of manganin, 84 percent of copper, 12 percent of manganese and 4 percent of nickel is reasonably close to the optimum for a general purpose resistance alloy. Fortunately the proportions need not be exact, as the melting losses make the composition somewhat difficult to control.

If the resistance of a sample of manganin is plotted against temperature, the curve will be found to be of the general shape of that shown in figure 1.

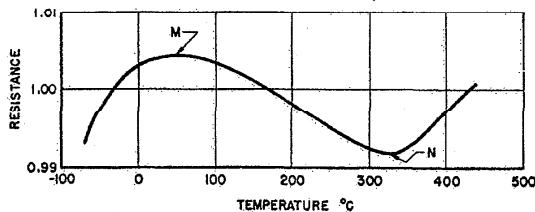

FIGURE 1. Resistance-temperature curve for manganin.

The maximum, *M*, of this curve is in the neighborhood of room temperature, being generally between 20° and 50° C, while the minimum, *N*, is at about 350° C. Somerville [3] found the difference in resistance between the maximum and the minimum to be about 1½ percent of the value at the maximum.

For an interval at least 15° to 20° C on each side of the maximum, the resistance-temperature curve for manganin is symmetrical with respect to a vertical axis. Its equation can be accurately represented by

$$R_t = R_{25} [1 + \alpha(t - 25) + \beta(t - 25)^2], \quad (4)$$

where R_t is the resistance at $t^\circ\text{C}$ and R_{25} is the resistance at 25° C. The coefficient α is the slope of the resistance-temperature curve at 25° C, and for manganin of good quality α has a value of 10×10^{-6} or less. The value of β , which determines the curvature at any point in the interval, is usually between -3×10^{-7} and -6×10^{-7} . This means that 10° C either side of the maximum the resistance is less than at the maximum by from 30 to 60 parts per million (ppm).

The temperature at which the maximum of resistance occurs is a function of the thermal and mechanical treatment of the manganin as well as of its composition. Different size wires drawn from the same melt will have maxima at different temperatures, that is, at any given temperature their coefficients of resistance will not be the

same. From the ingot, manganin is usually worked cold with an occasional softening by heating to a "red heat." If this annealing is done in air there is a selective oxidation of the surface that breaks down the alloy and leaves a coating with a relatively high conductivity. This surface layer may be removed by "pickling" in an acid, but again the action of the acid is somewhat selective, and the surface layer is left with a slightly different composition from that of the interior. These complications add to the difficulty of the control of the quality of manganin wire. In addition, the completed resistance coils are usually baked at about 150° C for 24 to 48 hours in order to stabilize the resistance. This baking also affects the temperature coefficient of the wire by amounts depending upon the size of the wire and the length of time of the baking. All of these factors make it difficult to produce resistors with the maximum at the best temperature, usually between 20° and 25° C. However, precision resistors of good quality usually can be obtained with temperature coefficients in that interval of not more than 10 ppm/° C.

Temperature coefficients of resistance change little with time, and if changes do occur in their values there is very probably an accompanying large change in resistance. Standards that are stable in resistance need not have redeterminations of their temperature coefficients. Although the data are meager and only the order of magnitude is known, it appears that for manganin resistors a change in resistance of one part in a thousand will be required to change the slope of the temperature-resistance curve at room temperature by one or two parts in a million per degree centigrade.

Constantan.—A series of alloys of nickel and copper containing 40 to 60 percent nickel, with a small amount of manganese to improve their mechanical properties, all have practically the same electrical properties. These alloys are sold as "constantan," or under various trade names, for use as thermocouple materials, and have thermoelectric powers against copper of about $40 \mu\text{V}/^\circ\text{C}$. However, except for their large thermoelectric powers the electrical properties of these alloys are remarkably similar to those of manganin.

The resistance-temperature curve for constantan is similar to that for manganin shown in figure 1. Its maximum is at or near room temperature with the minimum around 500° C. The difference in resistance between the maximum and minimum is somewhat less than for manganin, and the curvature in the neighborhood of the maximum is also less. As a consequence, constantan changes somewhat less in resistance over the ordinary range of atmospheric temperatures than does manganin. Its stability with time is about the same as that of manganin. At room temperature the resistivity

of constantan is 45 to 50 microhm-cm as it is for manganin.

Resistance coils of constantan are sometimes used instead of manganin in values of 1,000 ohms and above. They may also be used in smaller denominations in cases where no difficulty will arise from the large thermal emf's, as for example in alternating current circuits.

Therlo.—When manganin was first developed a small amount of nickel was added to the copper and manganese in an attempt to reduce the thermoelectric power of the alloy against copper. With the proportion of nickel now used the thermoelectric power against copper at room temperature is almost the same, although of opposite sign, as when the nickel is omitted. However, the nickel improves the mechanical properties of the alloy and probably reduces the surface action during forging and annealing.

The development of therlo was another attempt to reduce the thermoelectric power of copper-manganese alloys against copper. Instead of nickel, an equal percentage by weight of aluminum was added to the copper and manganese. As its name implies, the resulting alloy had a very small thermoelectric power against copper at room temperatures, less than $1\mu\text{v}/^\circ\text{C}$. Its other electrical properties are almost identical with those of manganin. However, as the thermoelectric power of manganin against copper is only of the order of 2 or $3\mu\text{v}/^\circ\text{C}$, the improvement was of little significance.

At the National Bureau of Standards [4] an investigation has been made of copper manganese-aluminum alloys of the therlo type. There it was found that for a resistance alloy the best composition is 85 percent of copper, 9.5 percent of manganese, and 5.5 percent of aluminum. This alloy has nearly the same resistivity as manganin, its temperature coefficient at 25°C can be brought to zero by a suitable heat treatment, and the change in the temperature coefficient with temperature is about half that of manganin, at least in the ordinary range of room temperatures. Its thermoelectric power against copper at 25°C is only about 10 percent of that of manganin, and this thermoelectric power may be further reduced by the addition of a very small percentage of iron, without materially affecting the other properties of the alloy. The stability of such alloys with time was found to be equal to that of manganin. Except for unusual applications, the difference between manganin and therlo is of little importance and the alloys may be used interchangeably.

Gold-chromium.—An alloy of recent introduction, which appears to be very promising for some applications, is gold with slightly over 2 percent of chromium [5]. This alloy has a resistivity at room temperatures of about 20 times that of copper. By baking at fairly low temperatures the temperature coefficient can be made extremely

small. Resistors of this material have been produced such that the total change in resistance in the interval 20° to 30°C did not exceed a few parts in ten million. The thermoelectric power of this gold-chromium alloy against copper is several times that of manganin, being 7 or $8\mu\text{v}/^\circ\text{C}$ at 25°C . The stability of this alloy with time has not been thoroughly tested but preliminary results were promising.

For many applications the extremely small temperature coefficient of gold-chromium alloy makes its use desirable. However, the temperature coefficient must be adjusted for each coil by baking, and the cost of this adjustment limits the use of the material. Although the temperature coefficient may be made small at room temperature, the interval over which the coefficient is small is not more than 20° or 30°C . The temperature-resistance curve is similar to that for manganin, as shown in figure 1, but with *M* and *N* much closer together in temperature and in resistance.

Other Alloys.—It is probable that all resistance alloys that have small temperature coefficients at room temperature have temperature-resistance curves that are cubics, similar to that of manganin shown in figure 1. These curves are nearly straight in the neighborhood of the inflection points between the maxima and minima. The ideal resistance alloy for use in instruments would have this inflection point at room temperature with a zero slope. Moreover, the maximum and minimum should be at widely separated temperatures so that the zero slope would be obtained over the usual range of atmospheric temperatures. Of the alloys already discussed, only gold-chromium has the inflection point in the neighborhood of ordinary room temperatures, the others having small slopes because of use near the point of maximum resistance. None of these have small coefficients over a very large temperature interval.

Alloys of nickel and chromium are commercially available that have practically linear temperature-resistance curves over an interval of several hundred degrees centigrade, which interval includes ordinary atmospheric temperatures. Although the temperature coefficient is constant, it is too large for use in apparatus where the highest accuracy is required. Recent attempts to reduce the coefficients of these alloys by the addition of comparatively small amounts of other materials, such as copper and aluminum, appear very promising. It is quite possible that an alloy and heat treatment will be developed such that no correction for temperature will need be made, at least throughout the range of laboratory temperatures.

2. Spools, Winding and Adjustment

In the beginning of the electrical instrument industry, wire coils were wound on wooden spools

like those that are still used for thread. However, because of the demand for increased accuracy, these wooden spools have been entirely replaced by metal spools for resistors of high quality. The reason for the change to metal has been twofold. In the first place, the wooden spools absorb moisture in amounts dependent upon the humidity in the air, and expand or contract therefrom. This results in varying stresses applied to the wire, with accompanying changes in resistance.

A more important reason for the use of metal spools is the fact that they more readily dissipate the heat produced in a coil by the passage of the current. The wire is wound in rather intimate thermal contact with the metal spools, and the heat is readily transferred to the spools. The entire surface of the spools, both inside and outside, is effective in dissipating heat to the surrounding air. However, for wooden spools the area that is effective in dissipating heat is largely the exposed outer surface of the resistance wires. When metal spools are used, the temperature rise for a given heat dissipation depends primarily upon the size of the spool and only to a minor extent upon the size of the wire. However, the wire size should be selected so as to cover the spool as completely as possible, and if necessary the turns should be spaced to prevent bunching of the coil at one end of the spool.

For many alternating-current applications, the use of metal spools is undesirable or even out of the question. For such applications, when wire-wound coils are required, wooden spools may be used, although for these purposes ceramic spools have come into rather general use. The objections to ceramic spools for resistors of high precision are their poor heat conductivity and the fact that their temperature coefficients of linear expansion are very much smaller than for the resistance wire.

Metal spools are ordinarily of brass, which has a coefficient of thermal expansion nearly the same as that of the resistance alloys. This avoids large changes in stress in the coils because of temperature changes. The spools are ordinarily mounted with their axes vertical, and both ends should be left at least partially open in order to allow a ready flow of convection currents of air through the spools. Before being wound, the spools are enameled or covered with a single layer of silk, which is impregnated with shellac varnish and allowed to air dry.

The resistance wire is generally double-silk or silk and cotton covered, and often the wire is enameled before these coatings are applied. The correct length of resistance wire is cut, doubled at its center, and the center is attached by means of a thread near one end of the insulated metal spool. The two halves are then wound side-by-side (bifilarly) after which the free ends are tied down with silk thread.

High-quality resistors are wound with only one

layer of wire. Although this requires the use of smaller wire than for multilayer coils, there are several advantages. In the first place, the heat dissipation is more satisfactory for a single-layer coil, since a considerable temperature rise may be obtained in the center of a multilayer coil as a result of the passage of the current through the coil, and the load coefficients are usually large. Moreover, multilayer coils are more subject to change in resistance because of changes in atmospheric humidity (see section II, 6), and are usually found to be less stable in resistance with time.

After being wound, the coils are artificially aged by baking in air at about 150° C for 48 hours, after which they are kept for a considerable period of time before final adjustment. Some manufacturers impregnate coils before baking with a shellac varnish, while others impregnate them after baking with special waxes. The final adjustment is usually accomplished in two steps. The excess wire is cut off in order to make the resistance just slightly less than the nominal value. Copper lead-wires, which are usually somewhat larger in diameter than the resistance wire, are then silver-soldered to the ends of the coil. Final adjustment is made by filing or scraping the resistance wire near the end, care being taken to see that the metal cuttings are not forced into the insulation. Any filed part is finally painted with shellac varnish, which is allowed to air dry. For coils of the highest precision the interval between baking and final adjustment should be as long as practicable, an entire year being desirable.

3. Sheet-Metal Resistors

Precision resistors having values of 0.1 ohm or below are usually made of sheet manganin brazed or silver-soldered to heavy copper terminal posts.

Potential leads are attached as shown in figure 2. Here C and C are copper rods, with binding posts at the top, attached to the sheet of resistance material, S . The resistance material may be a single sheet of manganin or several sheets in parallel. The sheets are often not straight but are bent in an S-shape in order that greater lengths can be used. Additional binding posts P , P are used as potential terminals and are connected by copper wires soldered at some point on the copper terminal bars. For a resistor of this type the resistance is measured between the two branch points. This is to say, the resistance is equal to the ratio of the potential difference between the potential terminals P , P to the current flowing in and out the current terminals C , C . For standards, sheet-metal resistors are mounted in perforated containers with hard rubber or bakelite tops. These are often used in oil baths in order to facilitate the dissipation of the heat

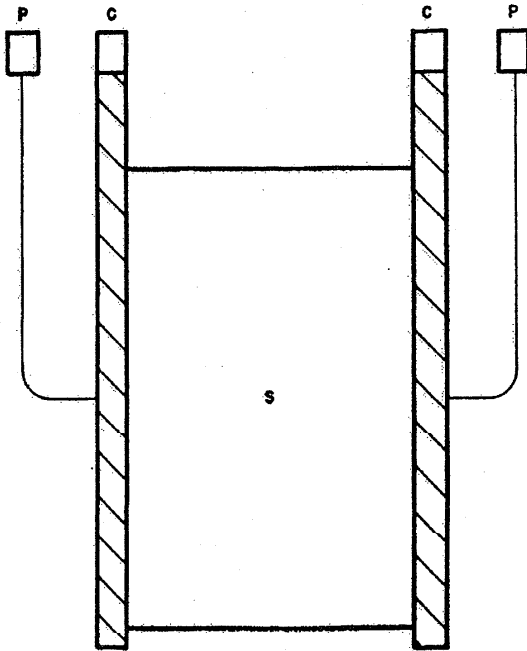

FIGURE 2. Sheet-metal resistor.

caused by the flow of current through the resistance element.

An accelerated aging of these resistors is obtained by heating in air at 150°C for 48 hours, as is done for wire-wound resistors. Final adjustment of the resistance may be accomplished by changing the points of attachment of the potential leads, the resistance decreasing as the points of attachment are lowered. Increases in resistance may be obtained by scraping or by drilling holes in the resistance material. Small changes can be obtained by filing the copper current posts, but the direction of the change is dependent upon the location of the potential leads.

Adjustment of sheet metal resistors is often accomplished by making U-shaped saw cuts in the sheet, with the open ends of the U's pointing in the direction of flow of the current. The U-shaped tabs so formed are bent outward and to them are attached the potential leads. Adjustment is made by increasing the length of the U cut. Lengthening one cut will increase the four-terminal resistance, whereas lengthening the other cut will decrease the resistance.

Not only may the resistance of a four-terminal resistor of the type shown be altered by changes in the points of attachment of the potential leads, but it is possible to change the temperature coefficient of resistance in the same way. In fact, the temperature coefficient is lowered at the same time as the resistance if the points of attachment

are lowered on the current posts [6]. This effect is large when the resistance of the copper terminal posts is high in proportion to that of the resistance element. For standards of very low resistance, large temperature coefficients may result unless the potential branch points are carefully located.

4. Accelerated Aging

After being wound, resistance coils are impregnated with a shellac varnish and given an accelerated aging by baking. The temperature for baking is limited by the silk insulation, which should not be heated above about 150°C , and the coils are usually baked at this temperature for 48 hours. As a result of the baking the resistance of a coil may decrease, sometimes as much as 1 or 2 percent, and a sufficient length of wire must be used to compensate for this change. After being baked, the resistance of the coils is much more stable with time than is that of unbaked coils. This aging process is often called "annealing", but it is doubtful that the improvement in stability results from the relieving of internal stresses in the wire, as happens during true annealing. In the two or three months immediately following their baking, resistance coils will ordinarily increase in resistance by an amount that is usually of the order of 0.01 percent. They then are ready for final adjustment.

Sheet-metal resistors are usually painted with a lacquer or shellac varnish as a protection of the surface. This coating limits the temperature to which these resistors can be raised during aging, and they are usually treated in the same way as insulated wire-wound coils, being baked at 150°C for 48 hours. Sheet resistors may be heated at high temperatures before being lacquered, but such treatment is apparently no improvement over baking at 150°C , as far as subsequent stability is concerned.

5. Annealed Resistors

As has already been stated, the usual baking of wire-wound and sheet-metal resistors is not done at a sufficiently high temperature to anneal the resistance material. As baking at 150°C improves the stability with time, it would be logical to expect greater stability if the heating were carried on at a sufficiently high temperature to obtain actual annealing. In the case of manganin this takes place between 500° and 600°C .

The annealing of metal is a complicated process, but the first step is probably a reforming of the metallic crystals to the shape they had before being cold-worked. This results in the relieving of many of the internal stresses that resulted from the distortions of the crystals. The amount of this restoration of the metal to its preworked condition depends upon both the annealing tem-

perature and the time. In general, the higher the temperature the shorter the time required for a given annealing. If the annealing is continued after crystals have been restored to their original condition, there may result an actual uniting of adjacent crystals, with an accompanying decrease in the mechanical strength of the material.

For base-metal alloys, annealing should take place in a vacuum or in an inert atmosphere to avoid a reaction between the metal and the surrounding air. Such reaction might take place inside the metal at the intercrystalline boundaries as well as at the surface of the metal. These reactions do not necessarily decrease the stability of resistance with time if the products are stable. There may, however, be a selective reaction that makes the material inhomogeneous, and this might have a considerable effect on the resistivity and temperature coefficients.

When a resistor is made by winding wire on a spool, the wire usually will not straighten if it is removed from the spool. This means that parts of the wire have been stressed past their elastic limit and a permanent deformation has taken place. For such a bent wire the portions farthest from the center of the spool have been elongated past their elastic limit, while the filaments nearest the center of the spool have been compressed beyond the elastic limit. Intermediate filaments are subjected to stresses that depend upon the changes in their length, which resulted from the bending. The stress distribution is from a maximum in tension to zero and then to a maximum in compression. These stresses are superimposed upon the stresses that were produced in the wire as it was being fabricated.

These internal stresses in a wire result in a slight change in the shape of its cross section. In addition to this change there is a change in resistivity, which results from the presence of the stress [7]. The resistivity is therefore not uniform across the wire, and the difference between parts of the wire may amount to nearly 1 percent in the case of manganin, and perhaps more for other alloys. Although the resistivity changes considerably when a wire is bent, there is not necessarily much change in resistance, as the change in resistance of the parts under compression may compensate for the change in the parts under tension.

The effect of annealing of a coil of wire is to reduce the internal stresses, thus making the resistivity more nearly uniform in the wire. It is probable that a slow annealing takes place at room temperatures, and the accompanying reduction in the internal stresses may be one reason for the change with time of the resistance of a coil of wire. Another cause for change might well be some reaction between the wire and the surrounding atmosphere. Both of these sources of

instability would be avoided or reduced if a coil were annealed and mounted in a vacuum.

Annealed resistors mounted in vacuo have been tested at the National Bureau of Standards and found to be very stable. It is difficult, however, to seal the coils in suitable containers for high evacuation. Equally good results have been obtained with annealed coils mounted in sealed metal containers filled with dry air. Whatever the effect of the air, an equilibrium condition is soon obtained when the supply of air is limited. Probably the most stable resistors that have been made are a group of annealed 1-ohm manganin resistors mounted in double-walled air-filled containers, now being used at the National Bureau of Standards [8] for maintenance of the unit of resistance.

Although good annealing improves the stability of sealed resistors, it is apparently of no special value for unsealed coils. When mounted in open containers, annealed resistors cannot be expected to be any better than, if as good as, those baked at 150° C. This is true even if the resistors are varnished or enameled after the annealing. None of these coatings is impervious to the atmosphere, and they merely retard any reaction between the air and the resistance material.

6. Effects of Humidity

It has long been known that wire-wound resistors undergo seasonal variations in resistance, being higher in resistance in summer and lower in winter. This effect is most noticeable in high resistance coils of small wire, and even in high-grade resistors may amount to several hundredths of a percent of the resistance. The effect is to a large extent a result of changes in average humidity, and is greatest in climates where there is a large difference in humidity between winter and summer. This seasonal change was first observed in the case of manganin resistors made with silk-covered wire. The accepted explanation was that the resistance changes resulted from dimensional changes of the shellac with which the coils were impregnated, as the shellac absorbed or gave off water vapor.

The effect of moisture on resistors has been thoroughly investigated by Dike [9], who came to the conclusion that the effect of changes in humidity is to change the tension in the silk with which the wire is customarily insulated. This change in tension changes the pressure transmitted to the wire by the insulation and hence changes the resistance. He also found that the effect of humidity on cotton insulation is opposite to that on silk, and by using a mixture of cotton and silk fibres for insulating the wire he was able to eliminate most of the seasonal changes in resistance that result from changes in humidity.

For standard resistors the effect of humidity

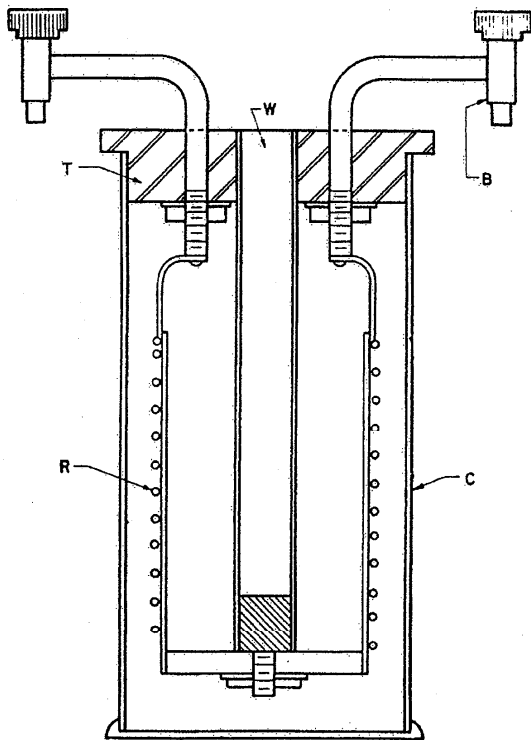

FIGURE 3. National Bureau of Standards standard resistor.

may be also eliminated by mounting the coils in sealed containers. This procedure was first advocated by Rosa [10] who designed the resistor shown in figure 3, known as the NBS type of standard resistor. In this figure, *R* represents the manganin coil mounted on a silk-insulated brass spool and baked as described in section II, 4. This coil is supported from the hard-rubber top, *T*, by means of the thermometer tube, *W*, which is so arranged that a thermometer can be inserted from the outside. The copper lead wires, which are silver-soldered to the ends of the resistance coil, are in turn soft-soldered to the copper binding posts, *B*. The hard-rubber top is screwed into the metal container, *C*, which is filled with a good quality light mineral oil. The binding posts, thermometer well and the threads by which the hard-rubber top is connected to the container are all sealed with shellac, which is not soluble in oil.

The purpose of the oil is to give good thermal contact between the resistor and the case and to facilitate the dissipation of the heat developed in the resistor by the current through it. In addition, the oil in effect increases the heat capacity of the resistor, thus increasing the current that it can carry temporarily without over-

heating. The objection to the oil is the fact that it may in time become somewhat acid, and the acid may corrode the resistance wire or injure the insulation.

The advantage of ready dissipation of heat combined with the advantage of hermetic sealing is found in the double-walled type of standard resistor [8] developed at the Bureau. In this type the container is made of coaxial cylinders only slightly different in diameter with the space between the cylinders sealed. The resistance element is mounted in this sealed space in good thermal contact with the smaller cylinder, which serves as the inside wall of the container. One of these resistors is shown in figure 4. The outside diameter of the container is 9 cm and its length 13 cm. The series of holes near the top are just above the double-walled part and are intended to increase the facilities for cooling, and the containers are left open at the bottom for the same purpose. These double-walled resistors readily give up heat to an oil bath yet are not affected by humidity changes. The sealed space in which the coil is mounted is filled with dry air, and no oil comes in contact with the resistance material.

The seasonal changes in resistance of standard resistors that arise from changes in humidity are readily eliminated, as has just been discussed, by sealing in metal containers. This arrangement is not satisfactory for large instruments and measuring apparatus, which are not readily sealed. If the cases of such equipment are reasonably tight a drier, such as calcium chloride, may be kept inside the case. This procedure is somewhat hazardous, since if not replaced with a sufficient frequency the drier may become dissolved in

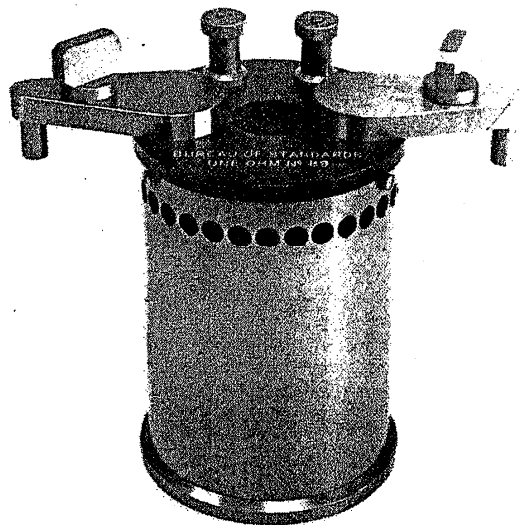

FIGURE 4. Double-walled standard resistor.

adsorbed water and be spilled on the coils. The use of silica gel avoids this danger. A more satisfactory method is to mount a heater in the apparatus and, by means of a thermostat, maintain the temperature of a metal box containing important resistors at a constant value, above that of the laboratory. In this way the relative humidity is kept always low and seasonal variations may be reduced. Additional advantages are that no temperature corrections need be applied when calibration is made under conditions of use, and that resistors will usually be more stable in resistance if kept at a constant temperature instead of being allowed to follow variations in laboratory temperatures.

7. Load Coefficients

The load coefficient of a resistor is defined as the proportional change in resistance caused by the production of heat in the resistor at the rate of one watt. This change, however, is a function of time. When a current starts flowing in a wire-wound resistor the wire very quickly takes up a temperature above that of the spool on which the wire is mounted. The amount of this change depends upon the thermal contact between the wire and the spool. If the current continues to flow, this initial difference in temperature is maintained, but the coil and spool continue to rise in temperature together. The maximum temperature that will then be attained depends upon the facilities for dissipation of heat by the spool, and often upon the facilities for cooling the material to which heat from the spool flows.

Suppose we have a standard resistor of the NBS type resting on a table and we send through it a sufficient current to liberate one watt in the coil. Within about 30 seconds the temperature of the coil will rise to a steady value about 1°C above that of its spool. Spool and coil will then continue to rise in temperature at the rate of about 10° or 15°C per hour, and if allowed to continue will in about 2 hours reach a steady temperature of some 10° to 20°C above that of the room. This may cause a permanent change in resistance, which, however, ordinarily amounts to only a few parts in a million. If, instead of being mounted in an oil-filled container, the same resistor had been left open in the air of the room, its final rise in temperature would probably have been less by some 50 percent and would have been reached in 15 to 20 minutes.

The rise in temperature of the resistance coil will be accompanied by a change in resistance, whose amount depends upon the temperature coefficient of resistance of the wire and also upon changes in stress in the wire because of dimensional changes of the coil and its support. For single-layer manganin coils mounted on brass spools the relative changes in dimensions are small, and the change in resistance results primarily from temperature

changes of resistivity. For such resistors the effect of the heating may usually be taken into account by measuring the temperature change and calculating the change in resistance from the temperature coefficients of the resistor. For sheet-metal resistors the effect of stress changes may be important and the calculated change cannot be relied upon.

It should be evident from the above discussion that the load coefficient of a resistor is a rather indefinite quantity, varying with time of flow of the current and with the environment of the resistor. To be of value it should be measured under conditions of use. Measurement is usually made by passing the desired current through the resistor and a second resistor connected in series, measuring the ratio of resistance both with negligible and with the required heating. This ratio may be measured by means of a bridge or a potentiometer, and the comparison resistor should be one that is not appreciably affected by the test current. A resistor of one-tenth or less the resistance of that under test should be used, and its load will be one-tenth or less than for the resistor under test. For the reference lower-valued resistor one that is known to have a small load coefficient should be chosen. If such a resistor is not available one with a low temperature coefficient should be selected, on the assumption that its load coefficient is correspondingly low, and its load coefficient should be roughly determined to make sure that it is small. This can be done by balancing the resistor in any bridge using a small test current. From an external source a large current is then sent through the resistor under test for several minutes, after which the extra circuit is disconnected and the bridge circuit is again balanced. This last balance must be made quickly before the heat from the large current is dissipated.

If a resistor is being used under conditions where the load changes its resistance, the amount of the change may often be determined experimentally. To do this the heating may be doubled, by increasing the current by 40 percent, and the resulting change noted. To a first approximation this doubling of the heating doubles the change in resistance, and twice the change should be subtracted algebraically from the final value. Such a procedure is especially satisfactory in the case of Wheatstone bridges, as the procedure will correct back to zero test current, whichever branch or branches are being changed by the current.

8. Stability of Resistors With Time

In applications where stability with time is of importance, as for instance for standard resistors or precision measuring apparatus, manganin is used almost exclusively. In such applications low temperature coefficients of resistance and small thermal emf's against copper are usually also required,

and few alloys other than manganin are suitable. Consequently, a discussion of the stability of resistors is largely a discussion of the stability of manganin.

Most national standardizing laboratories keep a selected group of manganin resistors, which are regularly intercompared and used for maintenance of the unit of resistance. The relative values of such standards are remarkably constant, the individual resistances not changing by more than one or two parts in a million per year with reference to one another and for some groups very much less. It is supposed that the average of a group remains constant to a high degree, but such stability can be only assumed. No method of measurement has been used that would detect with certainty changes of less than 10 or 20 parts in a million in the group as a whole. The international ohm was defined as the resistance of a mercury column of specified dimensions at the temperature of melting ice. However, such resistors have not been constructed with sufficient accuracy to demonstrate the performance of manganin resistors used to maintain the unit. Likewise, absolute ohm determinations have not been sufficiently reproducible to give such information. If the unit as maintained by means of manganin resistors were tested every ten years by comparing against mercury ohm or absolute ohm determinations, the apparent change would probably not exceed 10 or 20 parts per million. This could be just as well attributed to errors in realizing the unit experimentally as to

changes in the unit as maintained by the manganin resistors.

The average user of standard resistors is interested in the stability that may be expected from standards available commercially. In this connection, an analysis made in 1941 at this Bureau is relevant. Of nearly 600 standard resistors that had been submitted more than once to this Bureau for test, the average yearly change in resistance, without regard to sign, was found to be 8 ppm. Of the total only 2 percent averaged greater than 60 ppm per year, and for nearly 90 percent of all standards tested the annual change was 10 ppm or less. If signs were neglected there was no significant difference between the average yearly change of sealed and unsealed resistors. This would appear to mean that sealing merely reduces seasonal variations without improving the long-time stability. However, if regard is taken of sign, the performance of sealed and unsealed resistors was quite different. In this case the average yearly change was about -0.3 ppm for sealed and about $+5$ ppm for unsealed standards. That is to say, sealed standards about as often decrease as increase in resistance with time, whereas the change in unsealed standard resistors is predominantly upward. In connection with the sealed resistors it is interesting to note that practically the same result would have been obtained if the unit of resistance had been maintained by supposing the average value of the 400 sealed resistors had remained constant, as was obtained by assuming the average of a group of 10 selected resistors of special construction to be constant.

III. Methods of Comparison of Resistors

1. Ammeter-Voltmeter Methods

Precise measurements of electrical resistance are made with comparative ease with bridge methods, an accuracy of a few parts in a million being readily obtained in the comparison of nominally equal resistances of say 10 or 100 ohms. Although the actual measurements are rather simple, special apparatus is required. For many types of resistors high accuracy is not desired and the measurements may be made with deflecting instruments, which are usually available in electrical laboratories. The most common method, where an accuracy of 1 or 2 percent is sufficient, is the ammeter-voltmeter method. In this method a measured current is passed through the resistor under test, and the potential difference across its terminals is also measured. The current is measured with an ammeter and the potential difference by means of a voltmeter, the resistance in ohms being the ratio of the voltmeter reading in volts to the ammeter reading in amperes, in accordance with Ohm's Law.

The accuracy that may be attained by the ammeter-voltmeter method depends upon the accuracy of the two instruments. However, there are a few precautions that must be observed. Referring to figure 5, if the voltmeter, V , is con-

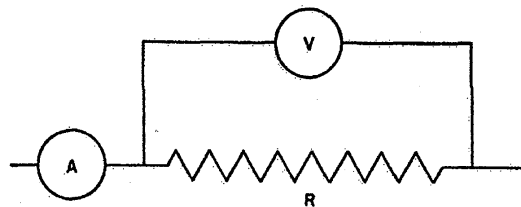

FIGURE 5. Connection for ammeter-voltmeter measurement of resistance.

nected as shown across the resistor, R , the current read by the ammeter, A , is the sum of the current through R and the current through the voltmeter. If the resistance of the voltmeter is large as compared with R , the current through the voltmeter

may be neglected and R may be calculated as the ratio of the instrument readings. If the resistance of the voltmeter is not large as compared with R , the latter may be calculated from the equation

$$R = \frac{E}{I(1 - E/IR_v)} \quad (5)$$

where R_v is the resistance of the voltmeter, its reading being E volts, and the ammeter reading I amperes. If the resistance of the ammeter is known or if it is negligible as compared with the unknown resistance, the voltmeter may be connected across both the resistance and the ammeter, as shown in figure 6. In this case the ratio of

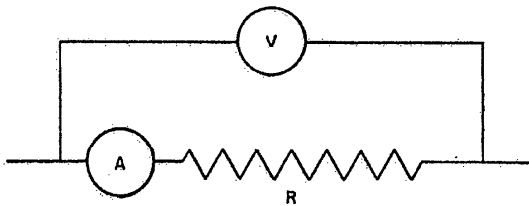

FIGURE 6. Alternate connection for ammeter-voltmeter measurement of resistance.

voltmeter to ammeter readings gives the total resistance between the points of attachment of the voltmeter, that is, the resistance of the ammeter and of the connecting leads is included. That is

$$R = \frac{E}{I} - R_A \quad (6)$$

where R_A is the resistance of the ammeter and of all lead wires between the points of attachment of the voltmeter leads.

With suitably calibrated instruments it is possible to measure resistance to 0.1 or 0.2 percent provided the instruments are of such ranges that large deflections are obtained. For this accuracy it is usually necessary to calibrate the voltmeter with the same leads as those that are to be used in the resistance measurements.

2. Ohmmeters

Ohmmeters are instruments for indicating directly on a scale, with a minimum of manipulation or computation, the resistance of the circuit connected across their terminals. They are available in a wide range from milliohmmeters reading to 0.001 ohm to megohmmeters reading to 50,000 megohms. Their accuracy is limited both by the calibration and reading of the indicating instrument and in the simple ohmmeter by their dependence upon a fixed value of voltage. They are, therefore, in general, not suited for applications

requiring high precision such as the determination of temperature rise or of the conductivity of line conductors. When used with circuits that are highly inductive or capacitive, the precautions appropriate for such resistance measurements should be observed.

Ohmmeters may be classified according to either their principles of operation, their source of energy, or their range.

The principles commonly used are: Simple ohmmeter, ratio ohmmeter, Wheatstone bridge.

In the simple ohmmeter a source, the voltage of which is assumed to be definite and to correspond to the calibration of the instrument, is applied to the unknown resistor and the resulting current causes an indicating instrument to deflect over a scale. This scale is so graduated that the pointer indicates directly the resistance in ohms (or megohms). In many cases provision is made by a magnetic or electric shunt to adjust the instrument at one point, usually at zero resistance, to fit the existing value of the voltage. In some of these instruments the final indication is by a vacuum-tube voltmeter, which measures the drop produced in a very high resistance by the current through the specimen.

In the ratio meter or "crossed-coil" type of ohmmeter, the current through the unknown resistor flows in one of the coils, while the other carries a current that is proportional to the voltage. The current is led to the coils by ligaments, which exert a negligible torque so that the moving system takes up a position that depends on the relative magnitude of the currents in the two coils. The scale can therefore be laid off to indicate resistance directly, and the indication will be independent of the voltage used, provided that the resistor under test obeys Ohm's Law.

The designation "ohmmeter" is also applied (though perhaps incorrectly) to certain forms of the Wheatstone bridge in which the dial that adjusts the balance is calibrated to read directly the value of the unknown resistance.

3. Potentiometer Method

It was pointed out in section III,1 that the ammeter-voltmeter method for measuring resistance is complicated by the current drawn by the voltmeter. Such complications may be avoided by using a voltmeter of some type that requires no current from the circuit being measured, i. e., electrostatic or vacuum tube voltmeters.

Potentiometers are also suitable for the measurement of potential difference when it is desired to avoid drawing a current from the source of potential difference. They are especially good in cases where an accuracy of 0.1 percent or better is required, as such accuracy is difficult to attain with deflecting instruments. Where a potentiometer is available, the ammeter-voltmeter method may

be modified so as to use the potentiometer to measure the current through the unknown resistor as well as the potential difference across it. This requires the replacement of the ammeter with a standard resistor, and the measurement of the potential difference across the standard resistor yields the value of the current if this potential difference is divided by the value of the resistance of the standard.

Actually, if a suitable standard resistor is available, it is unnecessary to calculate the current through the unknown resistor. If the same current flows through the known and the unknown resistor, the ratio of the potential differences across the two is the same as the ratio of the resistances. Hence

$$X = S \frac{V_x}{V_s} \quad (7)$$

where X and S are the values of the unknown and standard resistances, V_x and V_s are the measured potential differences across X and S respectively. Care must be exercised in using this method to insure that the current through X and S remains constant during measurement. This may be verified by measuring the potential differences alternately several times.

High accuracy in the measurement of resistance can be attained with the potentiometer method if a good potentiometer and good standard resistors are used. It has an advantage over the ordinary Wheatstone bridge in that the resistance in terms of which the unknown is measured may be that of an actual standard resistor instead of one of the coils of the bridge. Standard resistors are so mounted that they are ordinarily more constant in resistance and hence more accurately known than are unsealed coils usually used in bridges. The potentiometer method, however, is more difficult to use as the currents through the potentiometer and in the measuring circuit must both be kept constant, whereas the balance of a Wheatstone bridge is independent of the current flowing through it. In comparing resistors, the accuracy of a potentiometer is not dependent upon the accuracy of calibration of the standard cell used with the instrument.

A type of measurement for which the potentiometer method is especially well suited is for the measurement of four-terminal resistors, which are parts of complicated networks, where connections to the resistors must be made through other resistors. The resistances in the potential leads, which connect to the potentiometer, have no effect upon the balance of the potentiometer. There may be, however, a reduction in sensitivity unless the damping resistor for the galvanometer may be changed to allow for these extra resistances.

4. Differential-Galvanometer Method

The differential galvanometer was formerly used rather extensively for the comparison of equal resistances. Such a galvanometer has two separate windings made as nearly the same as possible, so that when equal emf's are applied to the terminals of the windings, equal and opposite torques are produced on the deflecting element. The windings are constructed with two wires side-by-side, wound at the same time and as nearly as possible symmetrically with respect to the magnetic circuit.

For the moving-magnet galvanometer the field coils are wound in duplicate, and a small movable coil is usually connected in series with one winding. This moving coil is adjusted in position to compensate for any lack of equality of the fields produced by the two windings. Unfortunately this adjustment is different for different conditions of use. Moreover the differential galvanometer of the moving-magnet type has the same handicaps as others of the moving-magnet type. That is to say, the damping is difficult to control and elaborate precautions must be taken to avoid magnetic disturbances from external sources.

Many of the troubles of the moving-magnet galvanometer are avoided in the D'Arsonval, or moving-coil galvanometer, and this coil may be made in duplicate for differential use. However, this requires two sets of leads from the moving element, which are difficult to arrange, and which also in effect stiffen the suspensions and lower the sensitivity. With the need for greater and greater precision, the differential galvanometer has been gradually discarded, but it still is very satisfactory for some types of measurements.

In theory, the use of the differential galvanometer is very simple. A current, I , is passed through the standard, S , and the unknown, X , connected in series, and one winding, G , of the galvanometer is connected to the terminals of each resistor, as shown in figure 7. If the galvanometer circuits were exactly alike in resistance and opposite in their magnetic effects there would be no deflection if X and S were equal. These conditions on resistance and magnetic effect are difficult to

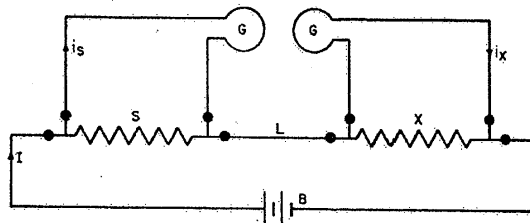

FIGURE 7. Connections of differential galvanometer.

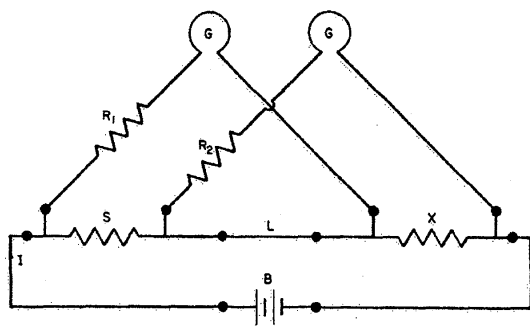

FIGURE 8. Kohlrausch's connection of differential galvanometer.

meet, and it is necessary to devise methods of use for which the conditions need be only approximately met, if high accuracy is to be attained. Such is that due to Kohlrausch [11], and known as his method of overlapping shunts.

For Kohlrausch's method the circuit is as shown in figure 8. The two galvanometer windings, G , are connected respectively across X and S , and in addition each shunt bridges the resistance, L , which is used to connect X and S in series. The resistance of L is usually small as compared with the other resistances. In series with the galvanometer windings are connected the resistors, R_1 and R_2 , one or both of which are adjustable. In addition, a special switch not shown must be used, which will interchange the battery B and the lead resistance L . This must be done without materially changing the current furnished by the battery. The effect of the interchange is to reverse the current through both galvanometer windings. The values of the adjustable standard, S , and the rheostat, R_1 or R_2 , are adjusted until there is no deflection of the galvanometer for either position of the battery, or until the deflection is the same in magnitude and direction for both battery positions. Under either condition of adjustment, S and X are equal.

In actual practice, where S and X are standard resistors under comparison, the larger is made adjustable by a precision rheostat connected in parallel, and the amount of the shunt required to make X and S equal allows an easy calculation of the difference in resistance between the two. The balance is exact even if the two circuits of the galvanometer are not exactly alike electrically or magnetically.

5. Bridge Methods

By far the largest proportion of measurements of electrical resistance are made by means of bridge methods. For resistors above 1 ohm the simple Wheatstone bridge is used, whereas for 1-ohm resistors and below the Kelvin double-

bridge is more suitable. The choice between the simple and the double bridge is usually made on the basis of the required accuracy.

It is difficult to attach a copper lead wire to a resistor by means of binding posts or other clamped connections without introducing an unknown contact resistance of the order of 0.0001 ohm. For resistors above 1 ohm such an uncertainty is usually negligible, whereas for a resistor of say 0.01 ohm the uncertainty is 1 percent. For standard resistors the contact resistance is often reduced by amalgamating the contact surfaces. For clean well-fitted contacts the resistance then amounts to only a few microhms, but the resistance of such contacts will rise with time as the copper combines with the mercury to form a granular material. This material should be removed every few months by scraping and wiping the surfaces.

Where accuracy is required, low-valued resistors are usually of the four-terminal type. For these, two leads are soldered or brazed to each end of the resistance material, as shown in figure 9. The



FIGURE 9. Four-terminal resistor.

resistance in question is that between the branch points at the two ends. That is to say, the resistance is the ratio of the potential difference between the terminals P, P to the current flowing in and out the current terminals, C, C . Methods of measurement are used such that any effect from the lead resistances is avoided or reduced to a negligible amount. For such a purpose the potentiometer method is suitable as no appreciable current is drawn through the potential leads, and the potential drop between branch points is independent of the magnitude of the lead resistances in the current circuit. Double-bridge methods balance out the lead resistances or connect them in high-resistance branches where they are negligible.

Simple Wheatstone bridge.—The simple Wheatstone bridge is primarily a group of four resistors connected in series-parallel as shown in figure 10. A current, I , is passed through the two parallel branches, and G is a detector connected to the junctions of the resistors as shown. It may be readily shown that if there is no potential difference across the detector, G , the relation between the resistances of the four arms is as follows:

$$\frac{X}{S} = \frac{A}{B} \quad (8)$$

or

$$X = S \frac{A}{B} \quad (9)$$

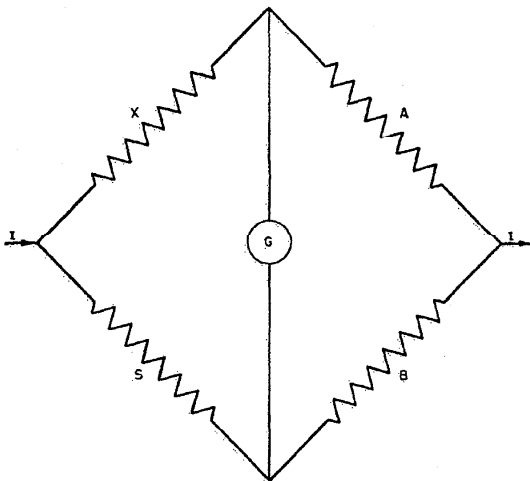

FIGURE 10. Wheatstone bridge.

The detector, G , is usually a galvanometer, and the lack of a potential difference across it is evidenced by a lack of motion of the galvanometer coil if a switch or key in series with G is opened or closed, or better, if the battery circuit is opened or closed. Opening or closing of the battery circuit should be avoided, however, if there is inductance or capacitance in the circuit of the unknown resistance or in any arm of the Wheatstone bridge. In measuring the resistance of a field winding of an electric motor, for example, the galvanometer may be damaged if its circuit is left closed and the battery circuit of the bridge is opened. In this case the current should be left on until a steady state is reached before testing the bridge balance by opening and closing the galvanometer circuit.

From the above equation it is evident that the resistance of any one of the four arms, say X , can be calculated if the resistances of the other three are known, or if one of the three and the ratio of the other two are known. The usual general purpose Wheatstone bridge is made in such a way that any one of several known resistors may be selected for use as either A or B and hence their ratio may have any one of a number of values. S is then a known resistor whose value may be adjusted in small steps over a wide range of resistance.

In commercial instruments the ratio arms A and B are usually coils that are connected into the bridge by inserting suitable plugs. As there are resistances in these plug contacts, which may be rather variable, it is desirable to use relatively high values of resistance for A and B in order to reduce the uncertainty in the resistance of the ratio arms. On the other hand, high-resistance coils are more affected by humidity and are less stable in resistance with time and therefore retain their calibra-

tion for a shorter time. Other things being equal, ratio coils of from 10 to 100 ohms are therefore about the best compromise.

The choice of resistance for the adjustable arm of a Wheatstone bridge is influenced by the same factors as the choice of resistances for the ratio arms. That is to say, the lower the value the greater the stability in resistance but the more troublesome the contact resistances become, and in the adjustable arm several contact resistances are required. Steps smaller than 0.1 ohm, which allow readings of the adjustable arm to about 0.01 ohm by interpolation from galvanometer deflections, are seldom used as it is not wise to rely upon the combined effect of the several contacts of the arm to be definite to much better than 0.01 ohm.

Wheatstone bridges for the measurement of resistance to 0.1 percent are available commercially at moderate prices. To this accuracy these can usually be relied upon without the application of corrections to the readings. However, for measurements to 0.01 percent, corrections to the readings of the ratio arms and of the rheostat arm must usually be applied, and the bridge must be maintained at the temperature of calibration within a few degrees. Primarily because of the effects of changes in humidity, calibrations of a Wheatstone bridge must be made rather frequently if an accuracy of 0.01 percent is to be attained. This is especially true where there is a marked change in ambient conditions. For example, between winter and summer the ratio coils and the rheostat arm may each change by 0.01 percent or more, and the errors may be additive rather than compensating. The use of air-conditioned laboratories improves the performance markedly, but even then it is advisable to make occasional spot checks by measuring standard resistors. Whenever possible, ratio arms below 10 ohms or above 1,000 ohms should be avoided, as should rheostat readings in excess of 1,000 ohms. This means that the Wheatstone bridge is best suited for the measurement of resistance in the range 10 to 10,000 ohms.

When an accuracy greater than 0.01 percent is required, special bridges are required or special techniques are used. One of the best of the special methods is that of substitution, in which the unknown resistor is replaced with a standard resistor or resistors having the same nominal resistance as that of the unknown. The bridge that is being used is then relied upon to determine only the difference between the standard and the unknown, and this difference need not be accurately measured. If the unknown and standard differ by 0.1 percent, the difference need be determined to only 1 percent to give the unknown to 10 parts in a million in terms of the standard. Nearly any good bridge can be so used without calibration, provided contact resistances are sufficiently constant that readings can be repeated to the desired precision. It is evident that the calibration of the measuring

bridge is of least importance when the standard and unknown resistances are nearest equal. Standard resistors are usually available only in decimal multiples or submultiples of an ohm and for many resistance measurements the lack of a suitable standard prevents the use of the substitution method.

Mueller bridge.—For the accurate measurement of odd-sized resistances, one of the best bridges is that designed by E. F. Mueller [12] of the National Bureau of Standards for use in resistance thermometry. This is a special bridge intended for the accurate measurement of resistances up to about 110 ohms. The effects of humidity changes are greatly reduced by mounting the resistors in a compartment that is electrically heated and whose temperature is maintained at 35° C by means of a thermostat. As this is a temperature to which the laboratory temperature seldom rises, the relative humidity in the compartment housing the resistors is kept low and variations in the low humidities have little effect on the resistances of the coils.

For the Mueller bridge the ratio arms are equal, and the arms can be interchanged to test the equality. A small slide wire is connected between the ratio coils, and the sliding contact is used as the branch point for the bridge as shown in figure 11. The operator can set the ratio arms to equality by properly proportioning the resistance of the slide wire between the two ratio arms by changing

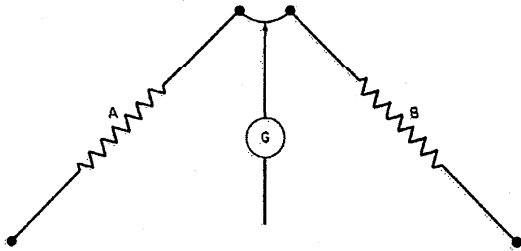

FIGURE 11. Ratio arms of Mueller bridge.

the setting of the slide contact. This setting is correct if no change in the bridge results when the arms A and B are interchanged. The remaining two arms are the adjustable rheostat and the unknown resistor, which must be of the four-terminal type. Resistance thermometers are usually of the four-lead type, and other resistors should be provided with four leads when they are to be measured on a bridge of this type. The method of connection of the unknown resistance is as shown in figure 12. *R* is the adjustable rheostat arm that will be discussed in detail later. *X* is a four-terminal resistor with lead wires L_1 , L_2 , L_3 , and L_4 connected to the binding posts 1, 2, 3, and 4, respectively. If the galvanometer is connected to binding post 2,

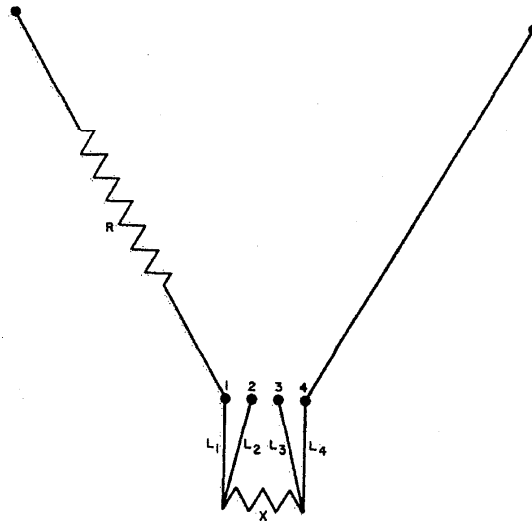

FIGURE 12. Connection of bridge to 4-lead thermometer.

the resistor *X* and the lead resistor L_4 are connected into the right-hand arm, and the lead resistor L_1 is in the adjustable arm, *R*. With equal ratio arms, *R* and *X* would be equal for a balance of the bridge only if L_1 and L_4 are equal. Instead of adjusting L_1 and L_4 to exact equality, their connections are interchanged and a second bridge balance is obtained, the average of the two balances being that which would be obtained with L_1 and L_4 equal. When L_1 and L_4 are interchanged, it is necessary to shift the branch point from lead 2 to lead 3 in order to keep *X* in the right-hand arm. In actual use, instead of the lead wires being interchanged, the internal connections of the bridge arms to the binding posts 1 and 4 are interchanged to obtain the same result. This interchange is effected by means of an amalgamated switch for which the uncertainty in contact resistance is only a few microhms.

The rheostat arm of the Mueller bridge is adjustable in steps as small as 0.0001 ohm. In order that such steps should not be masked by changes in contact resistance, special types [13] of decades are used. The 0.0001-ohm-per-step decade is approximately as shown in figure 13. With the

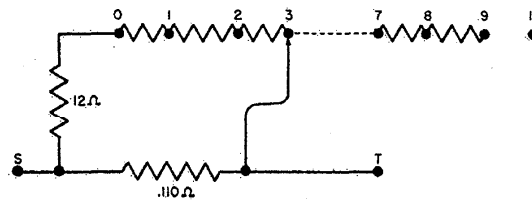

FIGURE 13. Shunt-type decade.

switch contact on the 0 stud, the resistances of 12 ohms and 0.110 ohm are connected in parallel, and the resistance between the terminals *S* and *T* is about 0.1090 ohm. When the switch contact is moved to stud 1, the 12-ohm branch is increased sufficiently to increase the parallel resistance from 0.1090 to 0.1091 ohm, an increase of 0.0001 ohm. Likewise when the switch is moved to 2 the parallel resistance increases to 0.1092 ohm, etc. Thus the resistance between the terminals *S* and *T* may be increased in steps of 0.0001 ohm, although the value is not zero when the switch is set to read zero.

The 0.001- and 0.01-ohm-per-step decades are made in the same way as the 0.0001-ohm decade. When these three decades are connected in series and all set to zero, there is a series resistance of about 1.6 ohms. However, since the bridge has equal ratio arms an equal resistance of 1.6 ohms may be included in the *X*-arm, and the value of *X* is measured by observing the increase in the resistance of the rheostat arm when *X* is inserted in its arm. A short-circuiting plug is provided with the bridge that connects together the terminals 1 and 4 of figure 12. The bridge is then balanced with and without this shorting plug, and the difference in the readings of the rheostat arm gives the resistance of *X*, and leads.

The purpose of the shunted type of decade that was described above is to reduce the effect of variations in contact resistances and transient emf's in the switch. Referring again to figure 13, it is seen that the switch contact is in the high resistance branch. The ratio of resistance for the two branches is about 100 to 1, and it may be readily shown by differentiation that the effect of a variation of switch contact resistance is reduced by the square of this ratio. Thus a contact variation as high as 0.01 ohm would vary the resistance from *S* to *T* by only 1 microhm, which is negligible in the rheostat arm where the minimum steps are 100 microhms. For the 0.001 and 0.01 decades, the ratio of currents in the branches is less than 100 to 1, and less variation in the switch-contact resistance can be tolerated.

The 1-ohm and 0.1-ohm steps of the rheostat arm are not made of the shunt type, as the resistance with the dial set on zero would be rather large. The contact resistances for the 1-ohm dial are thrown into the ratio arm *A*, as shown in figure 14. The bridge current is introduced through the 10 1-ohm coils of this decade, and the switch merely changes the point of connection of the ratio arm, without opening the circuit of the 1-ohm decade. In this case a variation of the switch contact resistance changes the resistance of ratio arm *A*. This effect is reduced by using high resistance ratio arms, *A* and *B* each being 1,000 ohms. The 0.1-ohm-per-step dial is arranged in the same way as the 1-ohm-per-step dial, with the switch contact in series with the *B* ratio arm. With the 0.1-ohm dial set at zero, all 10 of the

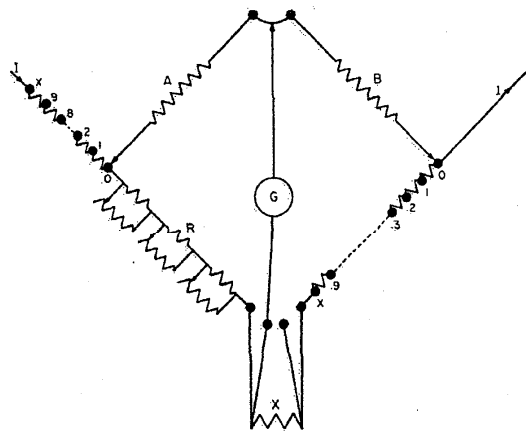

FIGURE 14. Switch connections for Mueller bridge.

0.1-ohm resistors are in series in the *X*-arm. When the dial reading is increased, the resistance is removed from the *X*-arm, the effect being the same as if equal resistance were added to the rheostat arm, *R*, since the bridge has equal arms. This may be seen from the following consideration. Assume that the bridge is balanced with the unknown resistor and the 10 steps of the 0.1-ohm dial all connected in the *X*-arm. If now *X* is increased by 0.1 ohm, the *X*- and *R*-arms may be brought again to equality by either increasing *R* by 0.1 ohm or by decreasing the resistance in series with *X* by 0.1 ohm. The readings of the dial in the *X*-arm are such that increases in readings of the dial correspond to decreases in the resistance in the *X*-arm.

The 10-ohm-per-step decade of the rheostat, not shown, is the only one that has contact resistances directly in series with the arm. A special type of dial that has amalgamated contacts is used for this purpose. Such contacts are uncertain by only a few microhms, which may be tolerated in the rheostat arm where the minimum steps are 100 microhms. For Mueller bridges available commercially, the galvanometer and battery are interchanged from the positions assumed in the above discussion. This in no way affects the validity of the conclusions.

Adjustable-ratio bridges. As has already been stated, the Wheatstone bridge shown in figure 10 is balanced if

$$X = S \frac{A}{B}, \quad (10)$$

and this balance may be realized by keeping *A* and *B* fixed and adjusting *S*, or by keeping *S* fixed and adjusting the ratio *A/B*. In most commercial Wheatstone bridges the balance is obtained with *S*. However, for comparing nominally equal resistances, bridges are sometimes constructed in which the ratio is adjustable.

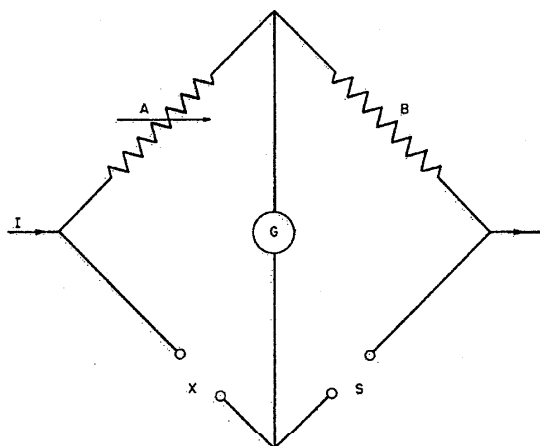

FIGURE 15. Limit bridge.

An adjustable-ratio bridge is very convenient for use in sorting large numbers of resistors that must be equal within given tolerances. Such a bridge may be constructed as shown in figure 15, where A and B are the two arms of a resistance ratio that is adjusted by changing A . A resistor is connected to the binding posts S , and the resistors that are to be compared with it are connected in turn to the X terminals. If the resistors are to be the same to, say, 0.1 percent, the arm A is made to have either of two values, which give ratios, A/B , of 0.999 or 1.001. This could be realized by making B 100 ohms and A either 99.9 ohms or 100.1 ohms, the latter accomplished, for instance, by making A equal to 100.1 ohms and having a plug to short-circuit 0.2 ohm of this total. The procedure is then to observe the direction of deflection of the galvanometer with either ratio setting and then change to the other ratio. If this causes a reversal of the direction of deflection of the galvanometer, the correct balance of the bridge is between the two ratio settings. In other words the ratio of X/S is between the two ratios 0.999 and 1.001, i. e., the two are equal within ± 0.1 percent.

Besides this use in limit bridges, adjustable ratio bridges may be used for precise measurements of resistors in terms of nominally equal standards. Such bridges when used in conjunction with the substitution method permit very accurate measurements of resistance. Such an adjustable ratio is the "direct-reading ratio set" described in section IV, 1, where the appropriate techniques are also discussed.

Kelvin double-bridge.—As has been already stated, four-terminal resistors are used in order to avoid uncertainties arising from variations in contact resistances. For precision work, resistors of 1 ohm or below are usually of the four-terminal type.

For measurement, a four-terminal resistor is usually connected in series with a four-terminal standard. The ratio of the potential differences across the two resistors is then determined when a current flows through the two. This ratio may be determined by means of a potentiometer or in terms of a resistance ratio by means of the Kelvin double-bridge.

The circuit of the Kelvin double bridge is shown in figure 16, where X and S denote the unknown and standard resistors, each with both current and potential terminals. The two are connected by means of a conductor L , preferably of low resistance as compared with X or S . The resistors A and B and also a and b provide resistance ratios that must be known, as must also be the value of S . This bridge is balanced if there is no change in the deflection of the galvanometer when the current circuit is opened or closed. When balanced the following relation holds between the values of the resistance:

$$X = S \frac{A}{B} + \frac{b \left(\frac{A}{B} - \frac{a}{b} \right)}{a + b + L} L. \quad (11)$$

This equation would be exactly the same as that for a simple Wheatstone bridge if the last term on the right side were zero or negligibly small as compared with the term $S A/B$. That last term can be made zero by making $a/b = A/B$, irrespective of the value of the link resistance, L . However, the smaller the value of L , the less important is any lack of equality between the ratios A/B and a/b .

In actual use two methods are employed for balancing the double-bridge. The resistors A and B , and also a and b may be fixed ratio coils so chosen that $A/B = a/b$ and the bridge balanced by varying S , which is an appropriate adjustable standard; or S may be a fixed standard resistor and the bridge balanced by adjusting the ratios A/B and a/b , keeping these ratios at all times equal.

When a double-bridge is to be balanced by means

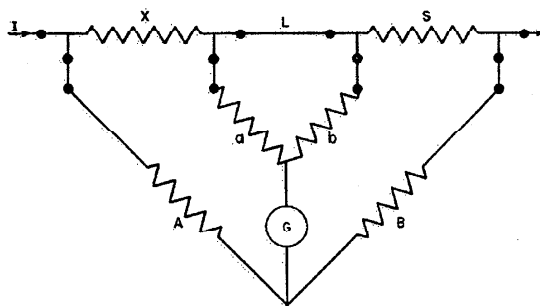

FIGURE 16. Kelvin double-bridge.

of an adjustable standard, care should be taken in connecting up such a standard in order to keep the resistance small between it and the unknown. Adjustable standards are usually made such that the position of one or both of the potential terminals is adjustable. As a result, varying amounts of resistance are left at the ends in series with the used part of the resistor. The adjustable standard should be connected in the circuit in the way that connects the larger part of unused resistance in the external circuit rather than between resistors so as to form part of the link resistance, L .

When a fixed standard is used for S , and the bridge is balanced by adjusting the ratios A/B and a/b , the most convenient arrangement is to have the ratios adjustable together. This is accomplished by having the same dial handle operate two dials together so that both ratios are changed simultaneously. This arrangement requires special apparatus, but such double-ratio sets are commercially available.

If not "ganged" together, the two ratios are changed separately but always by the same amount. Actually, however, it is not necessary to be able to adjust the auxiliary ratio, a/b , in known steps, and any convenient adjustable ratio, such as a slide wire, may be used. In this case the balance of the double bridge is by successive approximation. It is first balanced by adjusting the main ratio, A/B , after which the circuit is opened at the link, L , and a balance now obtained by varying the auxiliary ratio a/b . The link circuit is again closed and a new balance obtained with the main ratio. The procedure is repeated until the same balance is obtained with or without the link circuit's being open. Ordinarily the final balance is obtained after only a few sets of adjustments, and accurate results may be so attained. Since only one ratio need be known any apparatus having such a ratio, as for example a simple Wheatstone bridge, may be used in conjunction with a slide wire and a fixed standard resistor to make good measurements by the double-bridge method.

In work of the highest accuracy, account must be taken of the resistance of the leads that are used to connect the ratio arms to the unknown and standard resistors. There is also lead resistance in these resistors, between the branch points and the terminal binding posts, which is not necessarily negligible. One way of taking these lead resistances into account is to use such high resistances in the ratio arms that the connecting leads have a negligible effect. Usually, however, this reduces the sensitivity of balance of the bridge. A better arrangement is to make the lead resistances adjustable and select their ratio in such a way as to balance out their effects. A convenient method of adjusting the lead resistances is as follows: Referring to figure 17, the

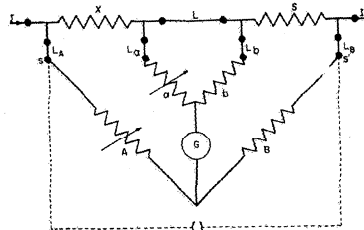

FIGURE 17. Kelvin double-bridge.

ratio A and B are such that their ratio is known only for the resistance between the two binding posts o and o' . The lead resistors L_A and L_B and the internal leads in X and S add to the resistance of A and B . This ordinarily prevents the ratio of the bridge arms from being the same as the known ratio of A to B . In other words

$$\frac{A+L_A}{B+L_B} \neq \frac{A}{B} \quad (12)$$

except under the condition that L_A and L_B are respectively negligible as compared with A and B , or under the condition that the ratio of the leads is the same as the ratio of A to B . That is

$$\frac{A+L_A}{B+L_B} = \frac{A}{B} \quad (13)$$

if

$$\frac{L_A}{L_B} = \frac{A}{B} \quad (14)$$

If the lead resistances are small as compared with A and B , the second equation need be only approximately satisfied.

The same considerations apply to the lead resistance L_a and L_b in the auxiliary ratio arms. Their effect may be made negligible by making their ratio the same as the ratio a/b .

The following procedure for balancing the bridge and eliminating the effects of the leads by adjusting their ratio may be followed. Arrangement is made for readily opening and closing the circuit at L and for short-circuiting the main ratio arms by connecting together s and s' . Shorting s to s' is the equivalent of reducing A and B both to zero, leaving only the lead resistances in the arms. If the ratios are ganged and nominally equal, the bridge is balanced in the following steps:

1. With the circuit as shown, the ratios A/B and a/b are adjusted until the galvanometer indicates a balance. This gives

$$\frac{A+L_A}{B+L_B} = \frac{X}{S} \text{ approximately.} \quad (15)$$

2. The main ratio A/B is now short-circuited

Circulars of the National Bureau of Standards

and the bridge is again balanced, by changing the ratio of the lead resistances. This may be done by adjusting the length of one lead wire, or a small rheostat may be used in series with one of the leads. This step makes the ratio of the lead resistances the same as X/S and hence to a first approximation also to A/B .

3. The short is removed from the main ratio and the link opened. The bridge then becomes the simple Wheatstone bridge shown in figure 18. To a first approximation

$$X/S = A/B = a/b = L_A/L_B, \quad (16)$$

and the simple bridge is unbalanced only if the resistances of the leads L_a and L_b are not in this same ratio. They are made in this ratio by adjusting L_a or L_b until the simple bridge shows a balance.

4. The link, L , is restored, giving again the double-bridge, and a second balance is obtained by varying the ratios A/B and a/b . This balance is more nearly correct than the first, as the leads have been approximately adjusted to their proper ratio.

5. The entire procedure is repeated until no further change is required in the settings of the main ratio, under which condition

$$X/S = A/B = a/b, \quad (17)$$

or

$$X = SA/B = Sa/b. \quad (18)$$

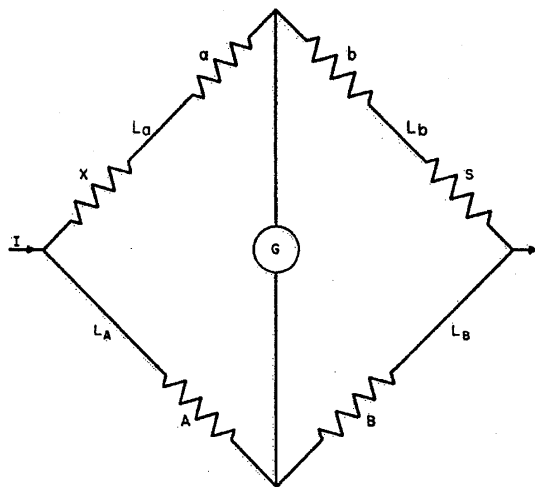

FIGURE 18. *Equivalent Wheatstone bridge.*

In case a/b is obtained from a slide wire, or a ratio that is adjustable but not known, the same procedure is followed as that outlined above. In this case, however, the balance for step 3 is obtained by varying the ratio a/b , if necessary making a fine adjustment of the ratio by varying the lead resistances L_a and L_b .

IV. Special Apparatus for Precision Measurements

1. Direct-Reading Ratio Set

The problem of calibrating precision resistance apparatus usually involves the comparison of resistors in the instrument with standard resistors of the same nominal value. This is most readily done by some substitution method, which is usually a method for determining differences between the resistances of the unknowns and of the standards. For well-adjusted instruments, the differences are small and need to be determined only approximately. For example, if the difference between the standard and unknown is 0.01 percent, the difference need be determined to one part in a million in terms of the standard.

One of the most convenient instruments for

the measurement of such differences in ratio is the "direct-reading ratio set." With this comparatively inexpensive instrument and a group of standard resistors, it is possible to calibrate accurately most types of resistance apparatus such as Wheatstone bridges, potentiometers, resistance boxes, etc.

The direct-reading ratio set is merely an adjustable resistance ratio with which bridges may be assembled, the remainder of the bridges being ordinary laboratory equipment. In its simplest form the ratio set is as shown in figure 19. The resistor B is a 100-ohm coil, which constitutes the fixed arm of the ratio. The adjustable arm consists of a fixed resistor of 99.445 ohms and three dials, D_1 , D_2 , and D_3 . The dial D_1 consists of ten steps of 0.1 ohm each, and D_2 and D_3 have

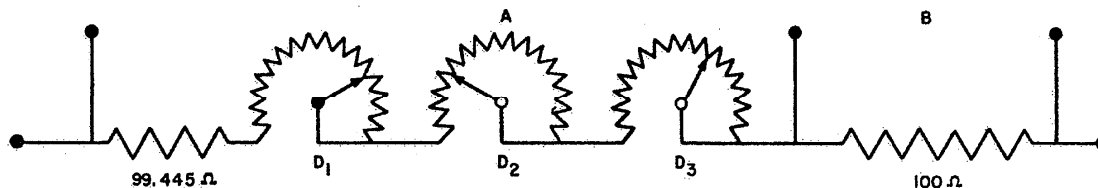

FIGURE 19. *Direct-reading ratio set.*

ten steps each of 0.01 and 0.001 ohm respectively. When at their center positions, the resistance of the three dials is 0.555 ohm, and with the fixed coil of 99.445 ohms the total of the arm is 100 ohms. Starting from these center positions, a step on D_1 will either raise or lower the A -arm by 0.1 ohm. The ratio of A to B is then changed from 100/100 to 100.1/100 or to 99.9/100, that is to say, it is raised or lowered by 0.1 percent. Likewise, steps on D_2 and D_3 change the ratio by steps of 0.01 and 0.001 percent respectively. By interpolation of the steps on the lowest dial, changes of 0.0001 percent may be determined.

Although the ratio set described above is correct in theory, variations in the resistances of the contacts of the dial switches would make the readings uncertain by several steps on the lowest dial when ordinary dial switches are used. The use of mercury switches will reduce the variations to a few microhms, but such switches are somewhat difficult to operate and keep in condition.

To avoid difficulties from variations in switch-contact resistances the design is usually modified so as to reduce their effect. This is done by placing the switches in high-resistance shunt circuits that require comparatively large changes in resistance to obtain small changes in the parallel resistance, as was done in the rheostat of the Mueller bridge (see section III, 5). The shunt circuits may be made sufficiently high that switch contact variations are negligible even when switches of moderate quality are used. An example of a shunted dial for obtaining steps of 0.1 ohm is shown in figure 20. With the dial set at 0 the resistance of the shunt arm totals 133.636 ohms, and this in parallel with the 30-ohm branch gives a total resistance of 24.5 ohms. When the dial is moved to stud 1, the resistance of the parallel combination increases by 0.1 ohm to 24.6 ohms, which requires that the shunt arm be 136.666 ohms. That is to say, between studs 0 and 1 there is a resistance of 3.030 ohms. Likewise

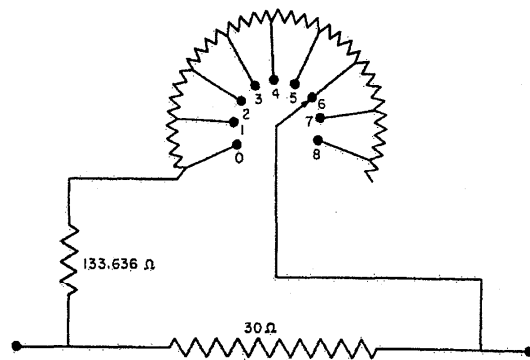

FIGURE 20. Shunt-type decade.

between studs 1 and 2 there is a resistance of 3.145 ohms so that when the dial is at 2, the shunt arm totals 139.811 ohms and the parallel combination is 24.7 ohms. The successive steps of the dial are not of equal magnitude, but the parallel resistance may be changed by 0.1-ohm steps from 24.5 to 25.5 ohms. For this the steps on the dial average about 3.6 ohms each.

Since a change in the high-resistance arm of about 3.6 ohms is required to change the parallel resistance by 0.1 ohm, it is obvious that switch contact variations in the high resistance arm will have their effect reduced by a factor of about 36 to 1. Their effect could be still further reduced by increasing the resistance of the shunt, the effect being reduced as the square of the ratio of the current in the high resistance branch to the total current.

In the same way, it is possible to make a decade for changing in 0.01-ohm or 0.001-ohm steps by means of a 150-ohm shunt in parallel with a 30-ohm resistor, the 150-ohm shunt to be changed in steps that average about 0.36 or 0.036 ohm respectively. Three decades with appropriate shunts and a 25-ohm series resistor could be used to obtain the equivalent of the A -arm of figure 19, but with the ratio not appreciably affected by normal variations in switch contact variations. An equivalent instrument is available commercially and, together with a group of standard resistors, is one of the most useful pieces of apparatus for the measurement of electrical resistance, especially for the calibration of resistance apparatus. Some of the procedures will now be described.

Comparison of two-terminal resistance standards, substitution methods.—In nearly all measurements where the highest possible accuracy is desired, a substitution method is used. That is, the change required to restore balance after replacing a standard with an unknown is measured. In comparing two-terminal standard resistors by substitution, the direct-reading ratio set is very rapid and convenient, and accurate results may be obtained. For this comparison a Wheatstone bridge is set up as shown in figure 21. A and B are the two arms of the ratio set, and Y is an auxiliary resistance of the same nominal value as the standard resistors under comparison. The two resistors are in turn placed in the mercury cups Q , and the bridge balanced by varying the ratio A/B . The difference in the ratio for the two balances gives the percentage difference between the two standard resistors. Thus, if the difference in the ratio for the two balances is one step on the 0.001 dial, one resistor is 0.001 percent higher than the other. If we are comparing 1,000-ohm coils, for example, the difference is 0.001 percent of 1,000 ohms, i. e., 0.01 ohm. Which coil is the larger is determined by observing whether the ratio is increased or decreased when the standard resistor is replaced by the unknown resistance. Actually the dif-

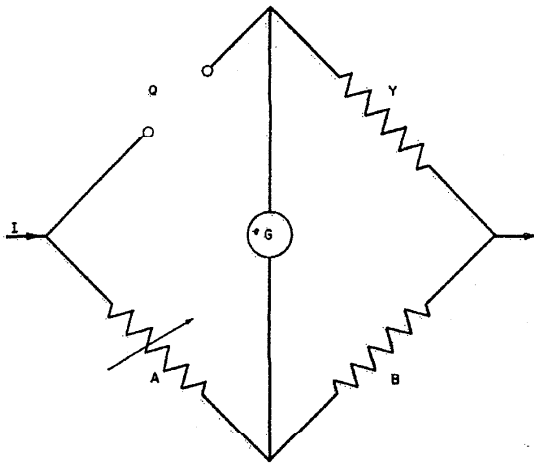

FIGURE 21. Wheatstone bridge for substitution method.

ference is determined in percentage of the arm *Y*, but for small differences any departure of *Y* from its nominal value is of no consequence.

Although the dials of a direct-reading ratio set change the ratios in decimal parts of a percent, it is desirable to mark the dials in parts per million. Thus the steps on the 0.001-percent dial would be marked, 0, 10, 20, etc., and the 0.01-percent dial would be 0, 100, 200, etc. Readings of the instrument and data taken from it are then whole numbers of moderate sizes rather than decimals. In the discussion that follows, it is assumed that the ratio set is marked in parts per million, and that corrections to resistors are also expressed in parts per million. Bridge readings and corrections to standards are then readily added and subtracted and calculations are greatly simplified.

In comparing nearly equal resistances by substitution, the lack of correct adjustment of the coils of a well-made ratio set will cause errors of much less than 1 part in a million. The variation in the contact resistance of the dial switches may be appreciable unless they are kept clean. The switches should be frequently cleaned and lubricated with a little good-quality light oil. When kept in good condition, the resistance of the three switch contacts should not vary as much as a thousandth of an ohm. From the values of the coils on the 0.001 percent dial, we see that a variation of a thousandth of an ohm will cause variations in the ratio of 1/3.6 of a part in a million.

In comparing resistances by the substitution method, the two balances of the ratio set should be made quickly so that temperature changes will not cause variations in the ratio set between readings. It is best to have all coils of the ratio set made from the same lot of resistance material. If this is done and manganin coils are used, a

change in temperature of 1 deg C should not change the ratio more than 2 or 3 parts in a million.

In spite of these sources of error, it is probably possible to compare standard resistors ranging from about 10 ohms to 1,000 ohms to within 1 or 2 parts in a million by the use of this ratio set. This, of course, requires that the set be well constructed, that a fairly sensitive galvanometer be used and that the resistances differ by not more than about a tenth of a percent. With resistances less than 10 ohms, the resistance of the mercury cup contacts may cause trouble. For this reason standard resistors smaller than 10 ohms are now almost always four-terminal resistors. Methods of comparing such resistors will be discussed later.

Another method for comparing nominally equal two-terminal standard resistors, which is practically equivalent to the preceding substitution method, is what might be called a double substitution method. In this latter arrangement, the two resistors under comparison are used to form two arms of a Wheatstone bridge, the ratio set forming the other two arms. The resistors are both mounted in mercury cups so that they may be interchanged without affecting lead resistances in series with them. After a balance is obtained by adjusting the ratio set, the resistors are interchanged, and a new balance is obtained. The percentage difference between the two resistors is half the difference between the two readings of the ratio set. This method is used for the same range of resistances as those measured by the simple substitution method, and about the same accuracy may be attained.

Comparison of four-terminal resistances with two-terminal resistance.—The direct-reading ratio set is convenient for the comparison of two-terminal with four-terminal resistances. Although the occasion seldom arises for the comparison of two-terminal with four-terminal standard resistors, it is often necessary to compare a standard resistor of one type with a resistance coil of the other type. Thus, in measuring the coils of many pieces of electrical apparatus it is impossible to make connection with the coils except through comparatively large connecting resistances. However, it is generally possible to make potential connections to the two ends of the coils and measure them as four-terminal conductors. In doing so, it is often convenient to compare them with two-terminal standard resistors.

In figure 22, *X* is a four-terminal resistor to be measured, having the current terminals T_1 and T_2 , and potential terminals P_1 and P_2 . The potential leads may contain considerable resistance in addition to that of the leads. *A* and *B* are the two arms of the direct-reading ratio set, and M_1 and M_2 are mercury cups into which either a two-terminal standard resistor or a short circuiting link may be placed.

Suppose we start with the galvanometer con-

nected at P_1 , a standard resistor nominally equal to X inserted in M_1 , and with M_2 shorted. We then have a simple Wheatstone bridge, which is balanced by varying the setting of the ratio set. After this balance is obtained, the galvanometer connection is shifted to P_2 , and the standard resistor is placed in M_2 , M_1 being shorted with the link. We again have a Wheatstone bridge but with the standard resistor and unknown interchanged. This interchange has been obtained without making any change in the resistance of the leads of the measuring circuit, except for possible variations in the resistances of the mercury cup contacts, which will be small if the mercury contacts are clean. The bridge is now again balanced by means of the ratio set. The percentage difference between the unknown and the standard resistor is half the difference in reading of the ratio set for the two balances. Unless the resistances under comparison are fairly large, it will be necessary to take into account the resistance of the short-circuiting link. This is done by subtracting the link resistance from the resistance of the standard resistor and considering that the resistor has this new value and is being interchanged with a link of zero resistance.

The resistance of the link can be measured as follows: Connect the link between two 1-ohm resistors to form two arms of a Wheatstone bridge, using the direct-reading ratio set for the other two arms, as shown in figure 23. L is the link, and A and B are the arms of the ratio set. Two balance readings are taken, first with the galvanometer connected at one end of L and then at the other. Half the difference in the readings is the value of the link resistance in percentage of the 1-ohm arms. If the link resistance is large, it may be necessary to use larger resistances in place of the 1-ohm coils. This method is very convenient for the measurement of small resistances such as links, connecting wires, switch contact resistances, etc. It is not a precision method but usually is sufficiently accurate for the measurement of resistances such as those just mentioned, which are to be used in series with larger resistances.

Substitution method for decades.—In the calibration of precision rheostats the occasion often arises for the measurement of a series of resistors of the same nominal value. This is readily done by the substitution method, using a standard resistor of the same value as the steps of the rheostat, reading differences on a direct-reading ratio set. The procedure is illustrated in figure 24. In this figure PR is the precision rheostat to be calibrated, and let us assume that the 10-ohm-per-step dial is to be checked. PB is then a plug box or any decade with 10-ohm steps, and M is a pair of mercury cups in which is placed a standard 10-ohm resistor. The arm Y is a 100-ohm resistor whose value need not be accurately

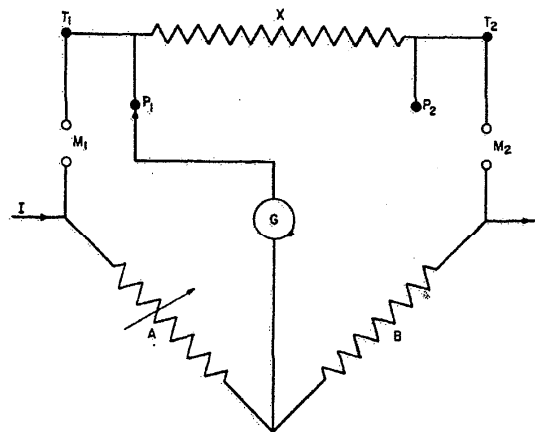

FIGURE 22. Measurement of 4-terminal resistor.

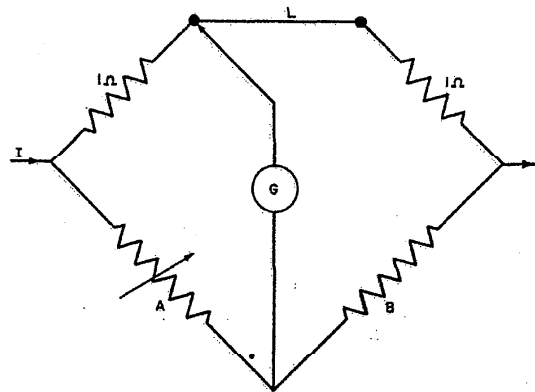

FIGURE 23. Measurement of lead resistance.

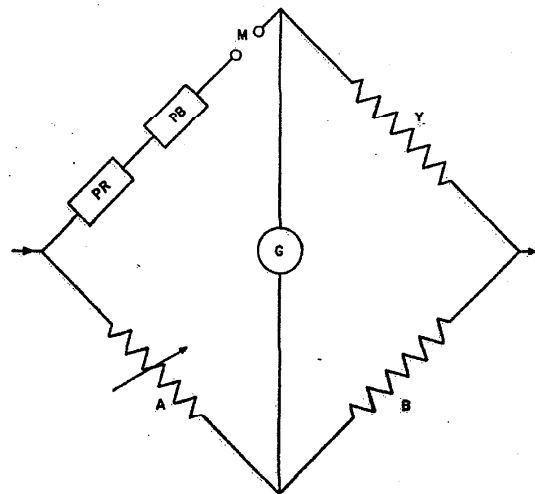

FIGURE 24. Test of decades by substitution.

known, and A and B are the two arms of a direct reading ratio set. The reading of the rheostat under calibration is set at zero, the plug box is set at 90 and the 10-ohm resistor is placed in M , making the total nominal resistance of the arm 100 ohms.

After the bridge has been balanced by changing the setting of A , the standard resistor is removed and the mercury cups shorted with an amalgamated copper link, and also the reading of PR is changed from 0 to 10 ohms. This has in effect substituted a 10-ohm step of PR for the 10-ohm standard resistor. The change in the reading of A required to again obtain a balance of the bridge is a measure of the difference between the step on the rheostat and the standard resistor, such difference being a percentage of 100 ohms. The second 10-ohm step on the rheostat is obtained by leaving PR at its 10-ohm reading, again placing the standard resistor in M and reducing the PB resistance to 80 ohms. These three resistors still total 100 ohms, nominally. The standard is now again replaced by a short-circuiting link, and PR is set to read 20 ohms, the resulting change being read from A . The change was produced by the substitution of the second 10-ohm step of the precision rheostat for the 10-ohm standard.

The procedure is continued, the steps of PR being successively substituted for the standard resistor. It should be noted that the steps of the auxiliary plug box, PB , are also being replaced by the standard resistor as PR is being increased and PB decreased in reading, the standard being cut in and out of the circuit. Data are therefore obtained for calibration of both PR and PB in terms of the standard resistor. Hence by this method, two precision rheostats may be calibrated simultaneously.

When 10-ohm steps are calibrated in a 100-ohm arm, the accuracy is reduced by one order. That is to say, differences in readings of the ratio set must be obtained to 0.0001 percent if the 10-ohm steps are to be determined to 0.001 percent. The method has the advantage that changes in the over-all resistance of the rheostat are determined under the conditions of use, which is often not the

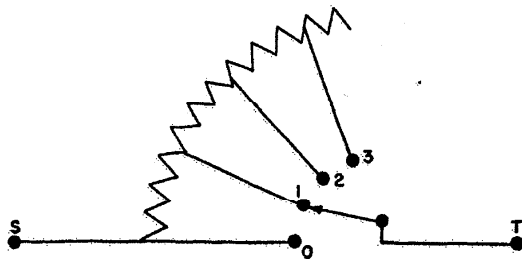

FIGURE 25. Dial connections.

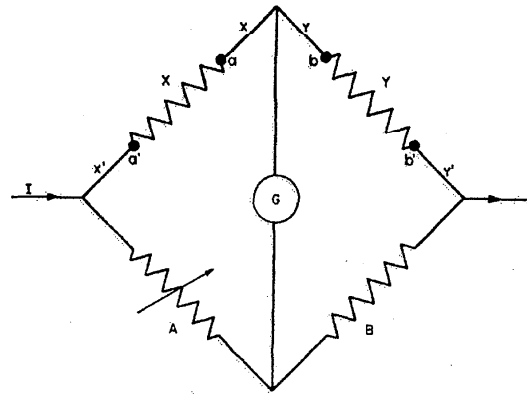

FIGURE 26. Lead resistances in Wheatstone bridge.

case when the individual resistors are measured directly. This may be seen by reference to figure 25, which represents the connections to one dial of the rheostat. The switch contact may be set on the contact studs marked 0, 1, 2, 3, etc., thus connecting 0, 1, 2 or more resistors between the dial terminals S and T . It should be noted that the resistors are usually connected in series and lead wires are connected from the junctions of the resistors to the switch contact studs. If the resistors are calibrated by measuring between studs 0 and 1, 1 and 2, 2 and 3, etc., two of these leads are included with each resistor. In actual use all the leads to the coils in use are not in the circuit, but only one lead is used for any setting of the dial. The above method of calibration determines the step as in actual use, the only additional data required being the resistance between terminals with the dial set at zero. This is readily measured by the method just described for the determination of link resistances. For any setting, this "zero resistance" must be added to the sum of the steps as determined by substitutions.

Comparison of four-terminal resistance standards.—Before taking up the question of the comparison of four-terminal standard resistors, let us consider briefly the effect of the lead wires of a simple Wheatstone bridge. In figure 26, X and Y are nominally equal resistances, and A and B are the two arms of a direct-reading ratio set. The conductors $x, y, x',$ and y' are used to connect up the bridge, and we will also denote their resistances by $x, y, x',$ and y' , respectively. The ratio of the resistances of the two arms containing X and Y is not in general the same as the ratio of X to Y because of the resistance of these connecting leads. If we could select leads such that the ratios x/y and x'/y' were the same as X/Y , the ratio of the two arms would be independent of the actual values of the lead resistances. That is, the balance would be the same as if the resistances of

the leads were negligibly small. It is possible to make the leads adjustable and make the ratios x/y and x'/y' the same as X/Y . In fact, such an arrangement is used at the National Bureau of Standards to reduce the effect of the leads when using the Kelvin double bridge. Instead of adjusting the leads, it is possible to balance the bridge with fixed leads, and then find what this balance would have been with the proper ratio of lead resistances, or with negligibly small lead resistances.

X and Y were assumed to have practically equal resistances. Instead of connecting the galvanometer as shown, suppose we balance the bridge with the upper galvanometer connection first at a and then at b . The average of the two readings is the value that would have been obtained had the conductors x and y been equal or negligibly small in resistance. Thus, by taking two readings we can take into account the effect of these two connecting resistances. This average balance reading is not the correct reading, however, unless also $x'=y'$, which is probably not true. We must now find what this balance would have been with $x'=y'$. To do this suppose we shift the current connections from the points shown to the points a' and b' . In doing so we remove the lead resistances x' and y' from the X and Y arms and connect them in series with the ratio arms A and B . If x' and y' are not equal, we will change the balance of the bridge by removing them from the arms X and Y . We will have still further changed this balance by adding them to the ratio arms A and B . Which of these changes is the greater depends upon the relative sizes of the two pairs of arms. If A and B are equal to X and Y , the changes will be equal. That is, with all arms nominally equal the balance would be changed a certain amount if the battery connections were shifted to a' and b' . This change is twice that which would have been obtained had we only removed x' and y' from the X and Y arms. The average of the readings before and after changing the battery connections is then the reading that would have been obtained with $x'=y'$ or both negligibly small.

Suppose, however, that A and B are ten times as large as X and Y . Then connecting x' and y' in series with A and B produces only a tenth as large a change as is caused by their removal from X and Y . Then ten-elevenths of the change in balance when the battery connections are shifted is due to the removal of x' and y' from the X and Y arms, and the remaining one-eleventh is due to the connection of the leads in the ratio arms. This enables us to calculate what the balance would be with x' and y' equal or negligibly small. As an example, suppose X and Y are each 10 ohms, and the arms of the direct-reading ratio set are 100 ohms. Assume that with the battery connected as shown in figure 26 and the galvanometer at a , the reading of the ratio set with the

bridge balanced is 5497 millionths, and with the galvanometer connection changed to b , the reading is 5613. Let us further assume that when we change the battery leads to $a' b'$, leaving the galvanometer connected at b , the balance reading changes to 5835. Then with leads of the proper ratio, or leads with negligibly small resistances, the balance would have been at $(5,613+5,497)/2+10/11(5,835-5,613)$; i. e., at 5,757.

As a matter of fact, this scheme for taking into account the connecting leads is practically never used in comparing two-terminal resistors. As the substitution method requires no consideration of the lead resistances, except to see that they are reasonably small, it is generally used. However, in comparing four-terminal resistances with a simple Wheatstone bridge we follow exactly the steps outlined above. Figure 27 shows a bridge set up for this purpose. A and B are the two arms of the direct-reading ratio set. X and Y are the four-terminal resistors under comparison, with current terminals $T_1, T_2, T_1',$ and T_2' , and potential terminals $P_1, P_2, P_1',$ and P_2' . The bridge is balanced when connected as shown, and a second balance is obtained after shifting the galvanometer connection to P_2' . The third balance is obtained after now changing the current connections from T_1 and T_1' to P_1 and P_1' , and calculations are made as above. The two arms X and Y are now interchanged and the three readings again obtained. From these two sets of readings, we get two balance points on the ratio set. Half the difference between these two balance readings is the percentage difference between the two four-terminal resistors.

Although the direct-reading ratio set was developed for use in the comparison of nominally equal resistances, it can be readily adapted for the comparison of resistances of any ratio provided some independent means is available for accurately

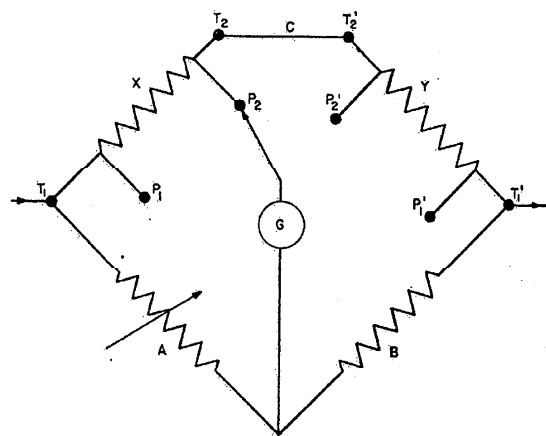

FIGURE 27. Comparison of 4-terminal resistors.

realizing the same resistance ratio. As an example of such a use let us consider the calibration of a 25-ohm resistor by comparison with a 100-ohm standard.

As has been described above, the direct-reading ratio set consists of the arm *A*, which is adjustable in small steps from values slightly below to slightly above 100 ohms. The *B*-arm is ordinarily a fixed 100-ohm arm. Suppose we change the *B*-arm by connecting an additional 300 ohms in series. The ratio *A/B* then becomes 100:400, which is adjustable in the same percentage steps as was the 100:100 ratio. Using two sets of mercury cups, let us set up the bridge shown in figure 28. The 25-ohm resistor is placed at *X* and the 100-ohm standard at *S*, and the bridge is balanced by adjusting *A*, and let us call this reading *A*. Also let *A*₀ be the reading *A* would have had if the *X* and *S* arms had been exactly in the ratio 25:100. If *c*₂ and *c*₃ designate the proportional corrections of *X* and *S*, the actual balance *A*, of the bridge, will be

$$A = A_0 + c_2 - c_3. \quad (19)$$

Since *A* is obtained experimentally and *c*₃ is known, this equation could be solved for *c*₂ if *A*₀ were also known. To obtain *A*₀, the arms *X* and *S* must be replaced by a resistance ratio of exactly 1:4.

To realize a 1:4 ratio it is necessary merely to have five resistors that are reasonably nearly equal. If one of these five is connected in place of *X* and the other four in series in place of *S*, the ratio will be only approximately 1:4. However, if the five resistors are placed one after the other in *X*, the remaining four each time being connected in *S*, the average of the five ratios will be 1:4 to a very high accuracy. In other words, the average of the five readings of *A* with the five resistors in turn at *X*, the remaining four in series in the *S*-arm, will be *A*₀, the reading of *A* for an exact 1:4 ratio. This value of *A*₀ can be substituted in eq 19 to allow the calculation of *c*₂, the proportional correction to the unknown 25-ohm resistor.

Another method of obtaining *A*₀ would be to balance the ratio set with one resistor at *X* and the other four at *S*, thus obtaining *A* of eq 19. The five resistors could then be substituted in any bridge and their differences determined. The terms *c*₂ and *c*₃ are then the amounts in proportional parts that the resistor in *X* and those in *S* differ respectively from the average value of the five.

To get an accurate value of the 1:4 ratio, the five resistors should have large enough resistances that the lead resistances of the *X* and *S* arms are negligible, or the lead resistances should be in the ratio 1:4. They may usually be so set with a sufficient accuracy by shorting *X* and *S* and adjusting the bridge circuit so obtained to a balance by changing the length of the lead wires. The five

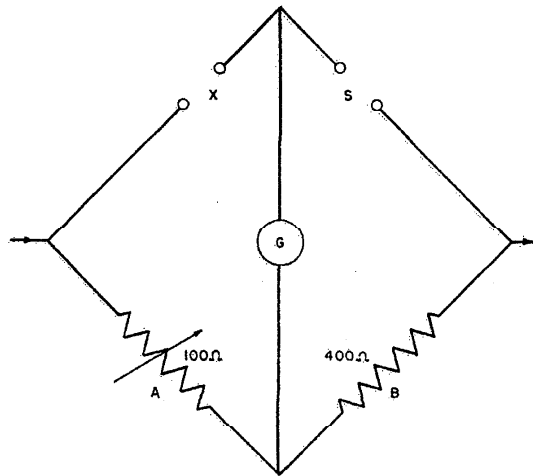

FIGURE 28. Bridge with 1:4 ratio.

resistors do not need to be equal to a very high precision. However, they must not differ by more than 0.1 percent if the average of the five ratios is to be correct to one part in a million.

A procedure analogous to this method of obtaining a ratio of 1:4 may be followed to determine any ratio 1:*n*, where *n* is an integer, by taking the average of *n*+1 ratios. It may also be used to determine any ratio *r*:*n*, where both *r* and *n* are integers. Starting with *r*+*n* equal resistors, *r* in one arm and *n* in the other, the resistors are rotated in a cyclic order until each resistor occupies each position once. The average of the *r*+*n* readings is the reading that would be obtained if all resistors were equal. Moreover, the resistors in either arm may be in parallel rather than in series.

In the calibration of high resistances, use may be made of the fact that the proportional correction to a group of nominally equal resistors is the same when they are connected in parallel as when connected in series. For example the ten 100,000-ohm sections of a megohm box may be connected in parallel and measured against a 10,000-ohm standard resistor. If the parallel group is high in resistance by 0.01 percent, the series resistance of 1 megohm will also be high by 0.01 percent. Here it is assumed that the ten sections are sufficiently near to equality that in the expansion

$$\frac{1}{1+c} = 1 - c + c^2 - c^3, \text{ etc.} \quad (20)$$

the second and higher powers of *c* are negligible, where *c* is the proportional amount by which the resistance of any section differs from the average of all. If this condition is satisfied, the ratio of

the resistance of n resistors in parallel to their resistance in series is exactly $1:n^2$.

The methods that have just been presented assume the use of a direct-reading ratio set. These methods, however, are entirely satisfactory when use is made of any ratio set that has small and definite steps. Such a set may be assembled from ordinary laboratory apparatus. For example, the adjustable 100-ohm arm might be made of a 105-ohm coil with a parallel decade box reading about 2,500 ohms. A change in reading of the decade box by 0.1 ohm would change the 100-ohm arm by about 1 ppm. The changes in the parallel resistance are not directly proportional to the change in the high resistance arm, but they may be readily calculated. This adjustable 100-ohm arm, together with a fixed 100-ohm resistor, constitutes an adjustable ratio set.

2. Universal Ratio Set

Precision standard resistors are usually made only in integral multiples or submultiples of an ohm. Consequently odd-valued resistors usually cannot be measured by a substitution method, except in a few cases where standard resistors can be combined to give a resistance nearly that of the unknown. The comparison of odd-valued resistors with standards is then not possible with a direct-reading ratio set, but a ratio set is required that is accurately adjustable over a wide range, at least from a 1:1 to a 5:1, or preferably to a 10:1 ratio.

A very convenient wide-range ratio set is one used at the National Bureau of Standards and called a "universal ratio set" [14]. This instrument is one having a constant resistance, between two external terminals, of about 2,111 ohms. An arrangement of dials is such that in effect a potential connection may be made at any point of the 2,111 ohms to the nearest 0.01 ohm. The ratio of the resistance between the potential point and one terminal of the set to the resistance between the potential point and the other terminal is therefore adjustable in small steps over a very large range. The device is the equivalent of a long slide wire with a movable contact, and its uses are analagous.

Suppose it were desired to measure a resistance of say 6.8 ohms by comparing it with a 10-ohm standard resistor. The two resistors could be connected in series and the combination connected across a slide wire as shown in figure 29, X being the unknown, S the standard, and W a slide wire. If a galvanometer, G , is connected to terminal a of the unknown and to the slide wire, a Wheatstone bridge is obtained that will balance with the slide wire at some point, 1, near the end. If now the galvanometer connection is changed successively to b , c , and d , successive balances will be obtained with the slide wire at 2, 3, and 4, respectively. The ratio X/S is then the same as

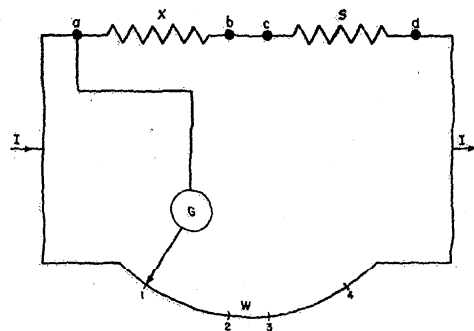

FIGURE 29. Comparison of resistors with slide wire.

$R_{1,2}/R_{3,4}$ where $R_{1,2}$ and $R_{3,4}$ are the resistances of the slide wire between the points 1 and 2, and 3 and 4, respectively.

It is very difficult to make a wire of sufficient length and uniformity that the ratio $R_{1,2}/R_{3,4}$ can be accurately determined. Instead of a slide wire, the universal ratio set makes use of a group of wire wound resistors so that the resistances between the balance points 1, 2, 3, and 4 can be accurately known. The arrangement of its dials is as follows. The highest dial consists of twenty 100-ohm resistors in series, with the dial contact acting as the potential connection to the instrument, as shown in figure 30. As the dial is rotated in a clockwise direction, the 100-ohm resistors are successively changed from the right to the left side of the contact. To change resistance from the right to left side in 10-ohm steps, two more dials are used, each having ten 10-ohm steps as seen in figure 31. These two dials are operated by the same handle but with one dial increasing as the other decreases in resistance. The total resistance between S and T remains constant for any setting of the 10-ohm decades,

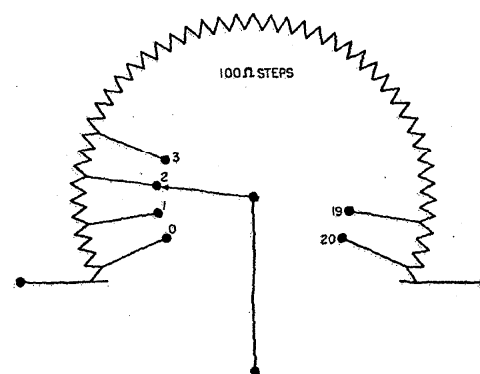

FIGURE 30. 100-ohm dial of universal ratio set.

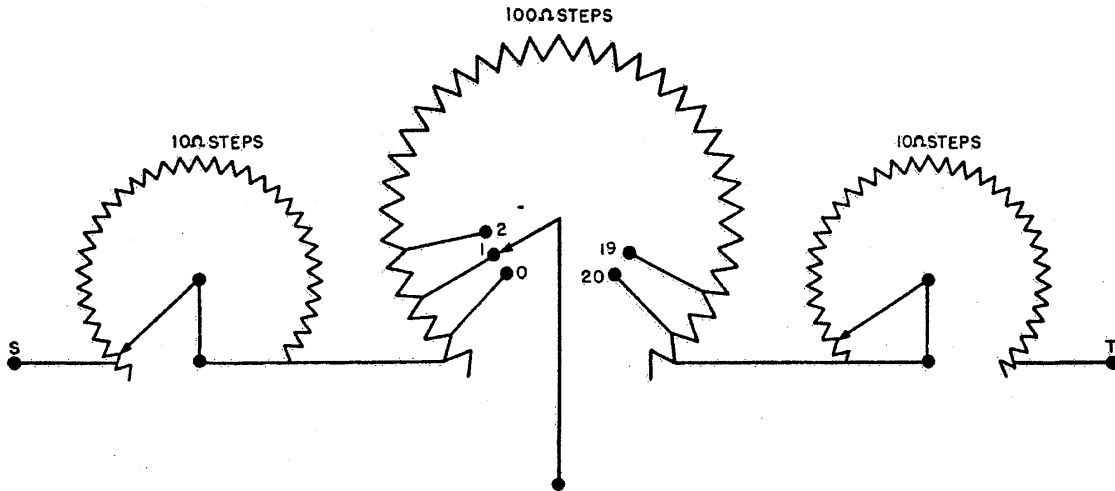

FIGURE 31. 100- and 10-ohm dials of universal ratio set.

and of course it is unaffected by the position of the 100-ohm dial switch that is merely a potential contact.

Steps of 1, 0.1, and 0.01 ohm-per-step are obtained in the same way as the 10-ohm steps, that is with two decades of each denomination operating together, one on each side of the 100-ohm dial. This scheme for the change of the potential point along a fixed resistance is essentially the same as that of the Feussner type potentiometer. The large number of contacts in series limits its use for precision work to circuits having a rather high resistance.

The universal ratio set is used only for the determination of resistance ratios and hence may be calibrated in terms of any unit. It is most conveniently calibrated in terms of an average step on the highest or lowest dial. This is done by comparing each step of a decade with the ten steps of the preceding dial starting with the smallest dials. Only the steps on one side of the 100-ohm dial need be tested, as the function of the other group is to keep the total resistance constant. A check of the constancy of the over-all resistance needs to be made for all readings of the double dials.

The use of a universal ratio set is the same as that of a slide wire as described in conjunction with figure 29, for the measurement of odd-sized resistances. It may be used in the measurement of four-terminal resistors and is especially convenient for the tests of potentiometers. The test of a potentiometer consists in the measurement of the ratio of the emf-dial resistance to the standard-cell resistance for all settings of the emf and standard-cell dials. These resistors are of the four-terminal type with potential connections brought out to emf and standard-cell binding posts. The method is satisfactory even when

some resistance is common to both the standard-cell and main-dial resistance. The arrangement for such a test is shown in figure 32. The ratio set, URS, which is shown as a slide wire, is connected in parallel with the potentiometer, the connection to the latter being made to the battery binding posts, BA+ and BA-. Readings on URS are made with the galvanometer connected successively to the SC and emf binding posts, for all settings of the emf dials. It should be noted that changes in the emf dials are merely changes in potential points and do not affect the readings obtained for the SC dial.

Potentiometers are provided with rheostats in the battery circuit for adjusting the potentiometer current. A change in this battery rheostat will change the differences in readings obtained on the universal ratio set but not the ratio of the differences. It is possible to make the ratio set direct-reading by adjusting the battery rheostat until the difference on the ratio set for the standard-cell posts is a decimal multiple, preferably 1,000, of the reading of the standard-cell dial. Corrections for the emf dials may then be read directly from differences across the emf terminals.

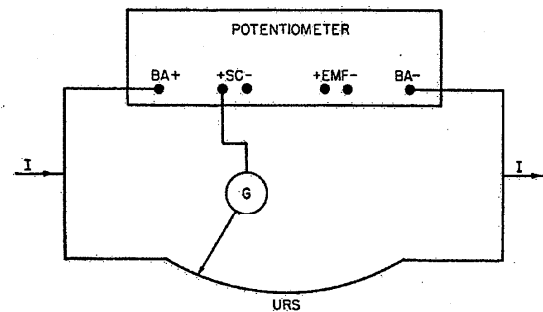

FIGURE 32. Check of potentiometer with universal ratio set.

V. Calibration of Precision Bridges

1. Calibration of Wheatstone Bridges

The circuit of a commercial precision Wheatstone bridge is usually as shown in figure 33. The two ratio arms A and B may have any one of several values, the choice being made by inserting a plug in series with the desired resistor. The rheostat arm, R , consists of four to six decades of not less than 0.1 ohm nor more than 10,000-ohm steps. The unknown resistor is connected to heavy binding posts, X , and a battery and galvanometer are connected to the external binding posts BA and GA . The switches S_B and S_G open and close the battery and galvanometer circuits.

In calibrating a bridge of this type, it is necessary to determine the resistance of the ratio arms between the branch points 2 and 3 or 3 and 4 rather than between the external binding posts, as the resistances from the branch points to the binding posts are usually not negligible. Also it is necessary to find the resistance between 1 and 4 with the rheostat dial, R , set at zero, as well as the corrections to the readings of the rheostat dials themselves. It is also necessary to measure the lead resistances between the branch points 1 and 2, as these are in series with the unknown resistance connected at X . The bridge balance determines the entire resistance of the X -arm, and the leads must be subtracted in order to obtain X itself. These four types of resistance measurements are made by application of some of the general principles previously discussed.

To measure the ratio arm B , for example, it is necessary to determine the four-terminal resistor having branch points 3 and 4. This is easily done by comparing it with a two-terminal standard of the same nominal value, making application of the method outlined in section IV, 1 and using the circuit shown in figure 34. The resistors a and b are the arms of a direct-reading ratio set, or any two ratio arms that may be adjusted in small known steps. As shown, one side of the galvanometer is in effect connected to the branch point 4, through the rheostat arm, R , which may be set at zero. The standard resistor is placed in the mercury cups, M_1 , and a short-circuiting link is placed across the other mercury cups, M_2 . After a balance is obtained by adjusting arm a , the standard and shorting link are interchanged and the galvanometer connection is shifted in effect to point 3 by connecting to the other X binding post. Half the change in the ratio that results gives the difference between the B -arm and the standard resistor.

The resistance of the A ratio arm may be measured in exactly the same way as for the B arm by making connection to the other GA terminal instead of the one shown. Some difficulty may arise from variations of the contact

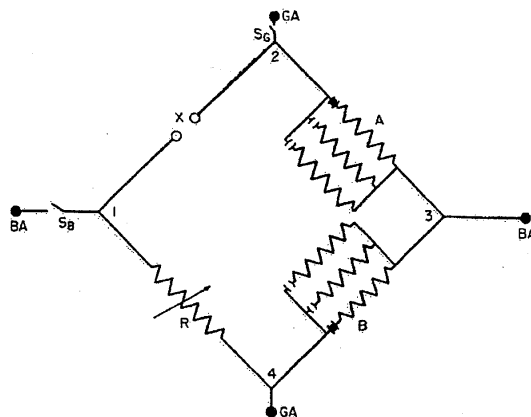

FIGURE 33. Wiring arrangement of Wheatstone bridge.

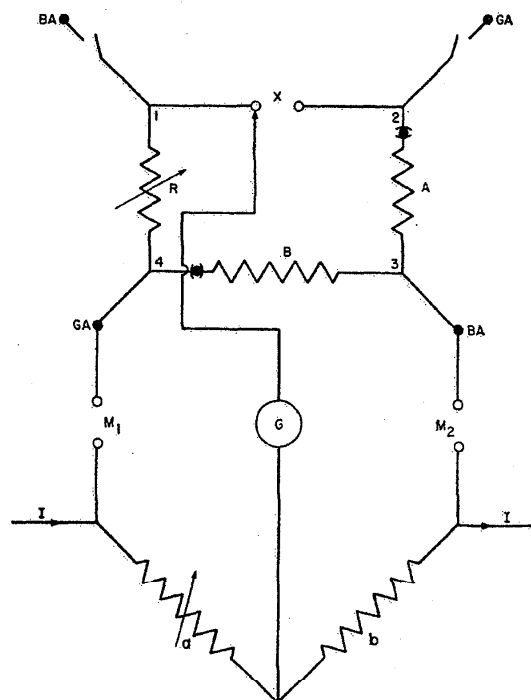

FIGURE 34. Check of ratio arm of Wheatstone bridge.

resistance of the galvanometer key, which will now be in the measuring circuit. This may be avoided by interchanging the adjacent X terminal and the GA terminal. The galvanometer would then be shifted from one X binding post to the GA binding post instead of from one X binding

post to the other. That is to say, the current and potential connections at point 2 may be interchanged. This will place the variable galvanometer switch resistance in series with the galvanometer where it will not affect the bridge balance.

The rheostat arm, R , may be calibrated like any other precision rheostat as described in section IV, 1. Connection should be made through the appropriate X and GA terminals. The resistance of the rheostat arm with all dials set at zero may be measured by connecting the arm between two equal resistors, using a direct-reading ratio set to connect up a Wheatstone bridge. The change in the reading of the ratio set is determined when the galvanometer connection is changed from one branch point of the rheostat arm to the other. This is the same as the method given in section IV, 1 for the measurement of lead resistances. In a similar way, the lead resistances in the X arm may be determined, taking readings with the galvanometer connection to branch points 1 and 2 and to the external X binding posts, with the latter connected by a shorting wire. The calculation must be made in two parts in order to exclude the resistance of the shorting wire.

For calculating X from the calibration data, it is convenient to express the corrections to the readings of the rheostat arm in ohms and to express the corrections to the ratio arms in proportional parts. The calculation in proportional parts involves merely a division of the correction in ohms by the nominal value in ohms. The value of X for a given balance is calculated from the equation

$$X = \frac{A}{B}(1+a-b)(R+r+r_0) - X_0 \quad (21)$$

In this equation a and b are the proportional corrections to the ratio arms A and B respectively, $R+r$ is the sum of the dial readings and corrections, and r_0 is the resistance of the rheostat arm with all dials at zero. The term X_0 is the resistance in ohms of the lead wires in the X -arm of the bridge. The factor $(1+a-b)$ is an approximation for $(1+a)/(1+b)$ and is accurate if a and b are small as compared with unity. If neither a nor b exceeds 0.001, the error from neglecting the second-order terms does not exceed two parts in a million.

2. Calibration of Thermometer Bridges

Because of the space limitations and structural difficulties, platinum resistance thermometers usually have resistances of less than 100 ohms. The common values are about 2.5 or 25 ohms, the actual values being so chosen that the change in resistance is very close to 0.01 or 0.1 ohm per degree centigrade change in temperature. In

order to read to 0.001° C, it is necessary to read these thermometers respectively to 0.00001 or 0.0001 ohm. For such measurements, bridges of special design are usually used.

In this country thermometer bridges for precision work are usually made with equal ratio arms. These arms are interchangeable, so that the use of an average value eliminates errors from lack of equality of the ratio arms, or the ratio arms may be interchangeable and adjustable so that they may be made equal at any time. With such interchangeable ratio arms, actual calibrations of them are unnecessary. The calibration of a thermometer bridge requires only a calibration of the rheostat arm.

In order to measure platinum resistance thermometers, which as stated above are usually not very high in resistance, with a bridge having equal ratio arms, it is necessary to have the rheostat arm adjustable in small steps. In fact, steps as low as 0.0001 or 0.00001 ohm are needed for work of the highest precision. In order to obtain such small steps, contact resistances cannot be used directly in the rheostat arm. Hence recourse is had to decades of the Waidner-Wolff type described above in section III, 5, in which the changes in resistance result from changes in the values of high-resistance shunts on comparatively small resistances. Switches are placed in the high-resistance shunts, where variations in their resistance will have a negligible effect. Decades of the Waidner-Wolff type cannot be set to have zero resistance, but the small changes start from an appreciable minimum value. However, for equal-arm bridges, compensating resistance may be placed in the X -arm. The value of the unknown is then measured by the increase in reading of the rheostat arm when the unknown is connected into the circuit.

The use of a resistance thermometer to measure temperature involves merely the determination of resistance ratios. Hence in calibrating thermometer bridges it is necessary to determine only relative values of resistance, which does not require the use of standard resistors. This calibration is readily made by the user, especially for bridges having equal ratio arms.

The calibration of such thermometer bridges requires as auxiliary equipment only an adjustable resistor that has the same range as that of the bridge rheostat. This resistor needs to be accurately adjustable, although the resistance need not be known for any position. Such an adjustable resistor may be assembled, for example, from a decade box with minimum steps of 0.1 ohm in series with an 0.1- or 1-ohm resistor, which is in turn shunted by a slide wire or a rheostat of fairly high resistance. This adjustable resistor is connected across the X -terminals of the bridge and is used to balance the bridge after the rheostat arm is set to certain required readings. The shunted 0.1- or 1-ohm should be attached to the X -termi-

nals so as to be adjacent to the rheostat arm. If a slide wire is used for the shunt, the sliding connection should be used as the galvanometer branch point so that its variable resistance will be in the galvanometer branch where it will not affect the balance. This, in effect, throws the shunted resistance partly in the X and partly in the rheostat arm. We then have the equivalent of the bridge shown in figure 35, the ratio arms A and B being

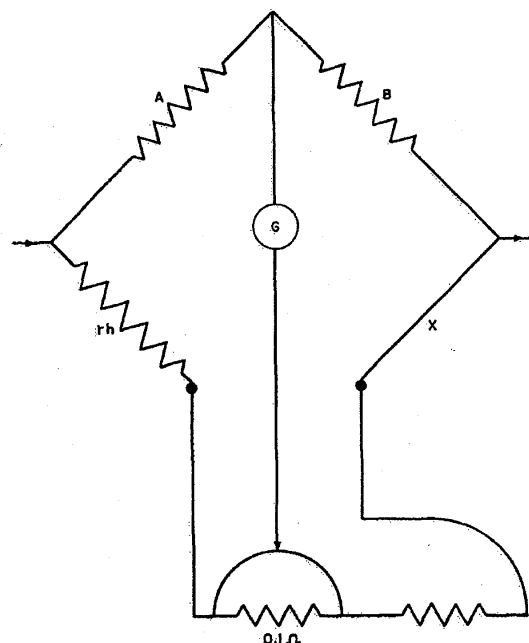

FIGURE 35. Calibration of rheostat arm of thermometer bridge.

accurately adjusted to equality. For a balance the rheostat arm, rh , and the X -arm must be also equal. If then X is changed by any amount, as by the insertion of a resistance thermometer in series, the rheostat would have to be changed by an equal amount to again balance the bridge. Thus, actual values of the rheostat arm need not be known if changes in the arm are accurately determined.

The procedure for checking the rheostat arm is usually as follows. The resistances of all steps in the arm are determined in terms of an average step on the smallest dial. The steps of the smallest dial are first intercompared to see that they are equal within 0.1 step, which is as accurately as the steps may be readily read by interpolation from galvanometer deflections. An easy way to intercompare the steps on the lowest dial is to set it at 0, the other dials being at any convenient

setting, and balance the bridge by adjusting X . The galvanometer deflection is now read when the lowest dial reading is changed from 0 to 1. Leaving this dial on 1, the bridge is again balanced with the X -rheostat, and the galvanometer deflection then again read for a shift of the lowest rheostat dial from 1 to 2. These alternate balances with rh and X are continued until the value of all the steps on the smallest dial of rh are determined in terms of galvanometer deflections. Unless one of the steps is defective, these should be the same to the nearest 0.1 step.

The steps on the second dial of rh should each equal the 10 steps of the lowest dial. They are measured in terms of the lowest dial by setting the lowest dial at 10 and the second dial at 0, the other dials being at any convenient value, usually small in order to obtain good sensitivity. With the lowest dial at 10 and the next larger dial at 0, the bridge is balanced by adjusting the value of X , after which the smallest dial is turned to 0 and the other dial shifted from 0 to 1. If there is now any galvanometer deflection, it is because the first step on the second dial is not the same as 10 steps on the smallest. The amount that they differ, in terms of steps of the lowest dial, is determined by reading the galvanometer deflection and evaluating this deflection by reading the additional change in deflection resulting from a change of the smallest dial setting from 0 to 1.

To measure the second step on the second dial its reading is left at 1 and the lowest dial now set at 10, a balance being obtained with X . The lowest dial is now set back to 0 and the other increased to 2, thus substituting the second step of the higher dial for 10 steps on the lower. The lack of balance is again translated into fractions of a step on the lowest dial by interpolation, using galvanometer deflections. This procedure is continued, each step of the second dial being compared in turn with the 10 steps of the lowest dial. A table is now made showing the value, in terms of steps of the lowest dial, of the first step of the second dial, the sum of the first two steps, sum of the first three steps, etc. This table will give the resistance corresponding to any reading of this dial in terms of steps on the smallest dial, which we might call "bridge units".

The values of the steps on the next higher dial are now determined in the same way but in terms of the 10 steps on the second dial, the unit again being a step on the smallest dial. The continuation of this process gives the resistance of each step of each dial in terms of the 10 steps on the preceding dial, from which finally is calculated the resistance for each setting of each dial in terms of bridge units.

The resistances as determined may be used with any resistance thermometer without converting their values to ohms. It is sufficient to standardize the resistance thermometer on this

same bridge, by measuring its resistance at known temperatures. However, it is often desirable to convert the values to ohms in order that the bridge may be used for the measurement of resistance other than that of thermometers. This is done by measuring the resistance of a standard by balancing the bridge with the standard resistor connected to the X -terminals. All readings of the rheostat should then be multiplied by the ratio of the resistance of the standard in ohms (rather, the difference between its resistance and that of the shorting connector) to its resistance in bridge units in order to convert the rheostat calibration to ohms.

The above procedure may be used for the calibration of the rheostat arm of any Wheatstone bridge, in terms of steps of the lowest decade and then in ohms, by comparison with a standard resistor. When used with equal ratio arms, the

“zero” resistance of the rheostat need not be determined, if two bridge balances are obtained, the first with the unknown connected to the X -terminals and the second with the unknown resistance short-circuited.

Many precision thermometer bridges provide a shorting plug for short-circuiting the resistor connected to the X -terminals. The galvanometer connects to the center of the shorting connector so that equal amounts of its resistance are inserted in the X and rheostat arms thus giving the same balance as if the shorting connector had a negligible resistance. With this method it is unnecessary to know the resistance of the shorting connector, although such resistance may usually be estimated with sufficient accuracy from its length and gauge size.

VI. Resistivity of Solid Conductors

1. Resistivity, Definition and Units

In the experimental work that led to the formulation of his law, Ohm found that the resistance, R , of a conductor is directly proportional to its length, l , and inversely proportional to its cross-sectional area, A . These experimental facts may be written in the form of an equation as

$$R = \rho \frac{l}{A}, \quad (22)$$

where ρ is a constant of proportionality whose value depends upon the material of the conductor and upon the units used in measuring l and A . This constant of proportionality is called resistivity.

The above equation, which defines resistivity may be written

$$\rho = R \frac{A}{l}. \quad (23)$$

No name has been assigned to the unit of resistivity, and consequently the unit is specified by stating the units used in measuring R , A , and l . This has resulted in the use of a large number of units, as each of R , A , and l may be expressed in more than one unit or subunit. From the above equation for ρ , it is seen that the value of ρ is numerically equal to that of R for a conductor having unit length and unit cross-sectional area. A cube is such a conductor, and this has led to the rather common expressions for the unit of resistivity “ohms per cubic inch” or “microhms per cubic centimeter”. These expressions are undesirable, because they imply that resistivity is the ratio of resistance to volume. It is logically better to say “ohms times square inches per inch”, “microhms times square centimeters per centimeter” or more briefly “ohm-inches” and “microhm-centimeters”.

2. Measurement of Resistivity

For a uniform conductor, it is merely necessary to measure the resistance of a known length of the conductor and then measure its cross-sectional area in order to determine its resistivity. For conductors of small cross section, it is usually possible to use a sufficient length that the resistance may be accurately measured with a simple Wheatstone bridge. For conductors of large cross section, it is customary to measure the resistance with a Kelvin double bridge in order to avoid errors from contact resistances. Wherever possible, the cross-sectional area is calculated from micrometer measurements. For conductors of small or irregular cross section, micrometer measurements are not sufficiently accurate, and the average area is determined from mass and density measurements.

For a uniform conductor the cross section, A , is

$$A = \frac{V}{l}, \quad (24)$$

where V is the volume and l the length of the conductor. But since, from the definition of density, D ,

$$V = \frac{m}{D} \quad (25)$$

where m is the mass, the preceding equation may be written

$$A = \frac{m}{lD}. \quad (26)$$

For many purposes it is sufficient to assume the density as that given in tables. If this is not sufficiently accurate, the specific gravity is determined from weighings in air and in water, and from these data and the density of the water, the

density of the conductor is determined by the equation

$$D = \frac{w_a}{w_a - w_w} D_w, \quad (27)$$

where w_a and w_w are the weights of the specimens in air and water, respectively, and D_w is the density of the water. At a temperature of 21° C, the density of water is 0.998 gm/cm³ and this value decreases uniformly to 0.997 gm/cm³ at about 25° C.

Instead of calculating A separately, the value of A from eq 26 may be substituted into eq 23, giving

$$\rho = \frac{R}{l} \times \frac{m}{l} \times \frac{1}{D}. \quad (28)$$

From this equation it is seen that the resistivity, ρ , equals the product of resistance per unit length and mass per unit length, divided by density. The length need not be the same for the resistance and mass measurements if the material is uniform. For two conductors having the same density, the ratio of their resistivities is the same as the ratio of their values for the product $R/l \times m/l$. This product is called "mass resistivity", and is a constant that is characteristic of the material of a conductor, being D times as large as the ordinary, or volume, resistivity. The mass resistivity is often specified in the purchase of conductors for electrical uses, and it is sometimes more readily measured than is volume resistivity. However, it is doubtful that this advantage is sufficient to compensate for the confusion that arises from the use of two types of resistivity.

It is usual commercial practice to specify percentage conductivity rather than resistivity, especially in the purchase of copper conductors. Conductivity is the reciprocal of resistivity, and percentage conductivity is obtained by dividing the resistivity of the given sample into that of the standard and multiplying by 100.

By international agreement, the resistivity of annealed copper is taken as 1.7241 microhm-cm at 20° C [15]. This value was selected from measurements of the resistivity of a large number of samples of high-purity commercial copper wire from both American and European refiners. The value was agreed upon as a standard for reference and was not intended to be the value for absolutely pure material. Copper has been produced with a conductivity of several percent greater than 100, which probably indicates a material of higher purity than that of the standard.

Some effort has been made to secure international agreement for a standard for the resistivity of aluminum, but so far copper is the only metal for which such a value has been adopted.

The measurement of the resistivity of a liquid may often be made by comparison with another

liquid of known resistivity. In this case measurements of dimensions may be avoided, as the known and unknown are given the same dimensions by placing them in turn in the same container or "conductivity cell." The ratio of their resistivities is then the same as the ratio of their resistances. Mercury is often used as the liquid of known resistivity, since its value is accurately known.

Although the resistivity of mercury is known to a high accuracy, its use as a liquid of known resistivity may lead to errors of considerable magnitude. In comparing the resistivity of liquids by placing them in turn in the same cell and measuring their resistance, it is tacitly assumed that the current distribution through the cell is the same for both liquids. This may be incorrect unless the liquids have very nearly the same resistivity, as the distribution of current in the cell depends to some extent upon the resistance of the metal electrodes. For high-resistivity liquids the resistance of the electrodes may play a negligible part in determining the current distribution, but in the case of mercury, which is a relatively good conductor, the current distribution may depend to a considerable degree upon the dimensions of the electrodes and upon the resistivity of the metal of which they are made.

In determining the resistance of a liquid, it is necessary to use an alternating-current bridge. When a direct current is used, the ions in the liquid will drift towards the electrodes thus making the density nonuniform. Moreover, polarization will often be produced by the liberation of gases at the electrodes. When measured with alternating current a conductivity cell is found to be electrically the equivalent of a resistor and a capacitor in parallel. This requires a balance of reactance as well as of resistance when the cell is measured in an alternating current Wheatstone bridge.

VII. References

- [1] N. B. Pilling, *Trans. Am. Electrochem. Soc.* **48**, 171 (1925).
- [2] R. S. Dean and C. T. Anderson, *Trans. Am. Soc. Metals* **29**, 899 (1941).
- [3] A. A. Somerville, *Phys. Rev.* **31**, 261 (1910).
- [4] J. L. Thomas, *J. Research NBS* **16**, 149 (1936) RP863.
- [5] J. L. Thomas, *J. Research NBS* **13**, 681 (1934) RP737.
- [6] F. Wenner and J. L. Thomas, *BS J. Research* **12**, 147 (1934) RP639.
- [7] P. H. Bridgman, *Proc. Am. Acad. Arts Sci.* **52**, 573 (1917).
- [8] J. L. Thomas, *J. Research NBS* **36**, 107 (1946) RP1692.
- [9] P. H. Dike, *Rev. Sci. Inst.* **7**, 273 (1936).
- [10] E. B. Rosa, *BS Bul.* **5**, 413 (1908-09) S107.
- [11] F. Kohlrausch, *Wied. Ann.* **20**, 76 (1883).
- [12] E. F. Mueller, *BS Bul.* **13**, 547 (1916) S288.
- [13] E. F. Mueller and F. Wenner, *J. Research NBS* **15**, 485 (1935) RP842.
- [14] F. Wenner and E. Weibel, *BS Bul.* **11**, 27 (1914) S223.
- [15] *BS Circular C31* (1914).

WASHINGTON, March 30, 1948.

Circulars of the National Bureau of Standards

U. S. GOVERNMENT PRINTING OFFICE: 1948