

CROSSMATCH[®]
TECHNOLOGIES

Protecting People, Property and Privacy

Certification of Iris Capture Devices

James L. Cambier Ph.D.
Cross Match Technologies
Palm Beach Gardens FL



- **ISO 19794-6, NIST SP 500-280 and other publications define recommended and/or mandatory performance criteria for capture of iris images**
- **The documents generally do not provide a detailed interpretation of the specifications or procedures for how to test conformance**
- **Perhaps what is needed is something analogous to the FBI Appendix F specification and test procedures for fingerprint images**
- **The intent of this presentation is to illustrate our interpretation of selected iris capture criteria and show some test methods we have developed**

- **Optical and Imaging Performance**
 - Spatial (optical) resolution
 - Pixel resolution
 - Signal-to-noise ratio
 - Illumination properties – wavelength, spectral distribution, safety
- **Hardware/Software Design**
 - Capture distance/volume
 - Exposure time
 - Capture speed, frame rate
 - Scan type, pixel depth, image margins
 - Connectivity, power
 - Emissions, immunity
- **Physical properties**
- **Environmental**
- **Packaging**

- **Generic test configuration**
 - Assembled from off-the-shelf instruments and free software
 - Vendor must supply software for image capture of test target
 - Test optical resolution, spatial resolution, SNR, etc.
- **Automated test system**
 - Test fixture for IScan2 dual iris camera
 - Integrated test target with back-illumination
 - Automated test software
 - Originally developed for factory testing
 - Test optical resolution, spatial resolution, SNR, illumination function
- **Illumination properties**
 - Off-the-shelf equipment
 - Spectral distribution
 - Eye safety

- **Procedures for MTF, SNR, Frame rate, pixel resolution**
- **Can be used with any camera device**
- **Camera vendor must provide software to capture image of test target and save in a file**
- **Test target is defined by ISO 12233 and is commercially available, but back illumination system may be needed**
- **Recommended measurement software is ImageJ, available at rsbweb.nih.gov/ij/download.html**
- **Optical resolution measurement requires ImageJ plug-in called SE_MTF, available at rsbweb.nih.gov/ij/plugins/se-mtf/index.html**

ISO 12233 Test Target

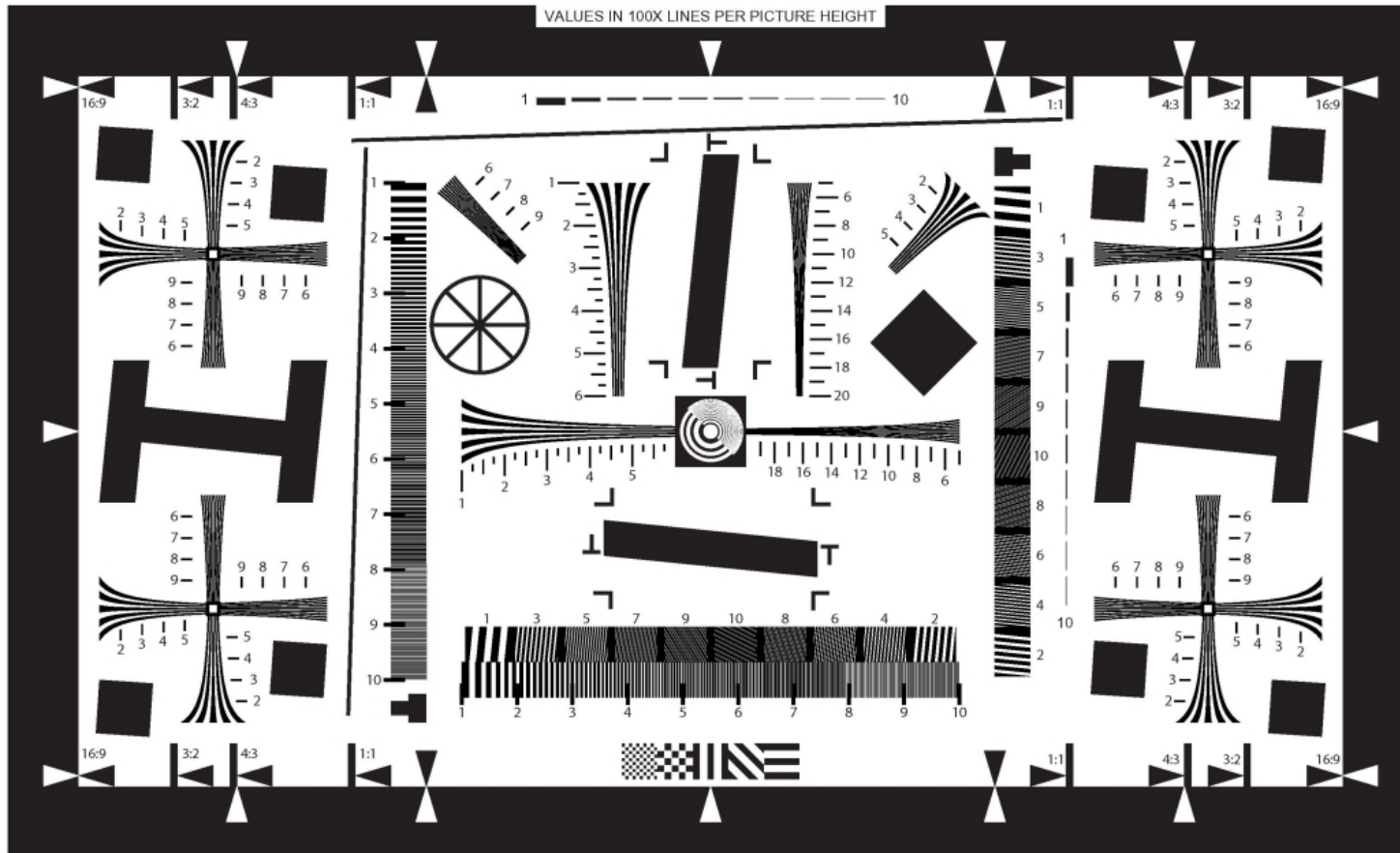

Drawn by Stephen H. Westin ©Cornell University This test chart is for use with ISO 12233 Photography - Electronic still picture cameras - Resolution measurements Chart Serial No. _____ Printed by _____

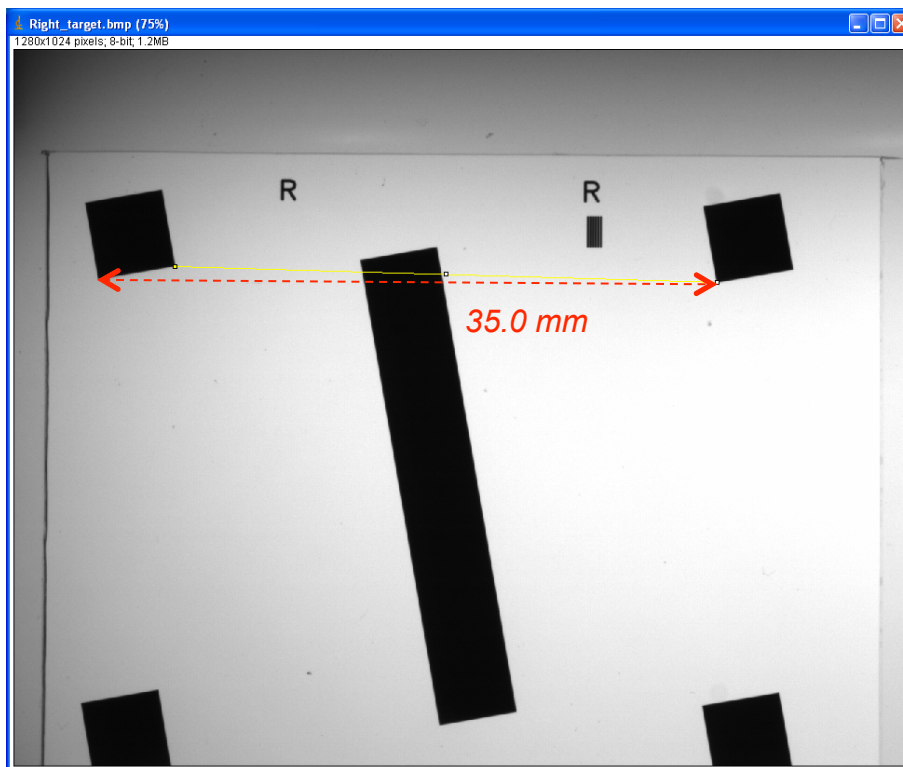
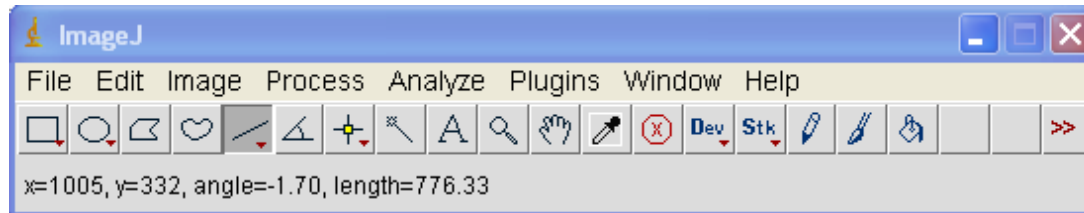

Measure known distance on target in pixels using ImageJ then compute pixels/mm

Measure both horizontal and vertical distances if pixels are not square

Distance = 35 mm

ImageJ line length = 776.33 pixels

Spatial Resolution is $776.33/35 = 22.2$ pixels/mm

This example uses CMT test target. Same procedure can be used with ISO 12233 target.

Two alternative measurements

- **Contrast Transfer Function (CTF)**
 - Uses target consisting of bar (“square wave”) patterns
 - Frequency stated as line pairs per mm (lp/mm)
 - Best approach for livescan fingerprint systems
 - Specified as relative contrast at a particular frequency
- **Modulation Transfer Function (MTF)**
 - Uses target consisting of sinusoidal patterns
 - Frequency stated as cycles per mm (cycles/mm)
 - Typically used for FP card scanners

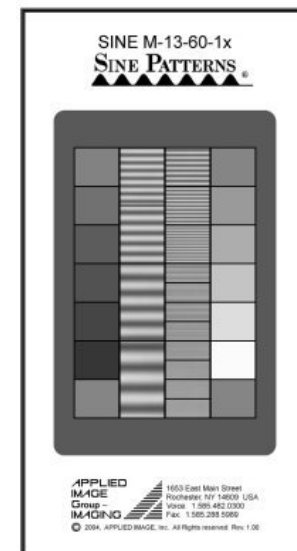
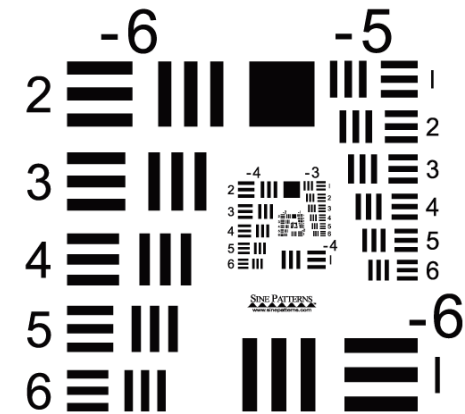

- **CTF is based on bar patterns**
- **MTF is based on sinusoidal patterns**
- **At a given frequency, CTF is related to MTF by the Coltman equation:**

$$C(f) = \frac{4}{\pi} \left[M(f) - \frac{M(3f)}{3} + \frac{M(5f)}{5} - \frac{M(7f)}{7} + \frac{M(9f)}{9} \dots \right]$$

- **If f is $\geq 1/3$ of the cutoff frequency (typically the Nyquist frequency defined by the pixel resolution) then a good approximation is**

$$C(f) = \frac{4}{\pi} M(f)$$

REF: Nill, N. Conversion between sine wave and square wave spatial frequency response of an imaging system, Technical Report MTR 01B000021, MITRE Corp., 2001 http://www.mitre.org/work/tech_papers/tech_papers_01/nill_conversion/index.html

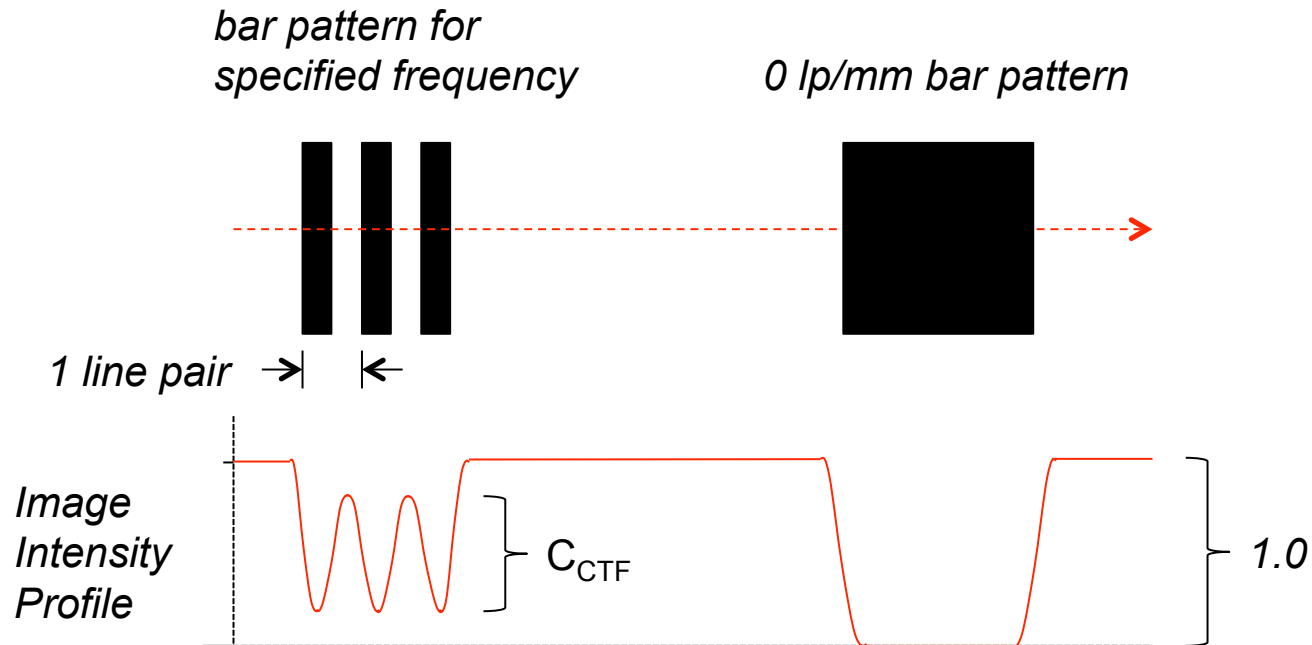

- At a particular bar spacing we measure the contrast relative to that for “zero frequency” edge (0 lp/mm)
- Contrast C_{CTF} is the relative amplitude for the bar pattern corresponding to the specified frequency
- For iris devices the specification is 60% contrast ($C_{CTF} = 0.60$) at 4 lp/mm (2 lp/mm in the revised version of ISO 19794-6)

- **Traditional MTF uses sinusoid patterns**
- **“Slant Edge” test method allows measurement of MTF from an angled edge pattern**
- **Provides MTF as a continuous function of frequency, not just at discrete frequencies**
- **Test pattern can be ISO 12233 and freely available software (ImageJ) can calculate MTF from the slant edge image**

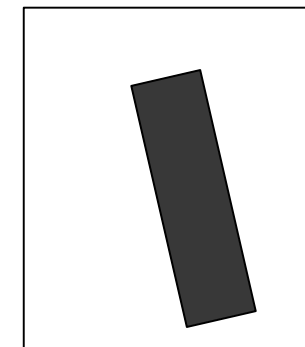
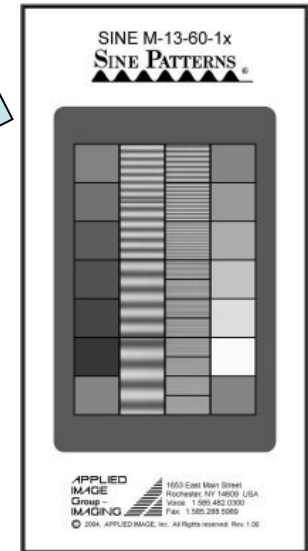

REFERENCES

1. Burns, P., Slanted-edge MTF for digital camera and scanner analysis, Eastman Kodak Company, Rochester NY
www.losburns.com/imaging/pbpubs/26pics2000burns.pdf
2. rsbweb.nih.gov/ij/plugins/se-mtf/index.html

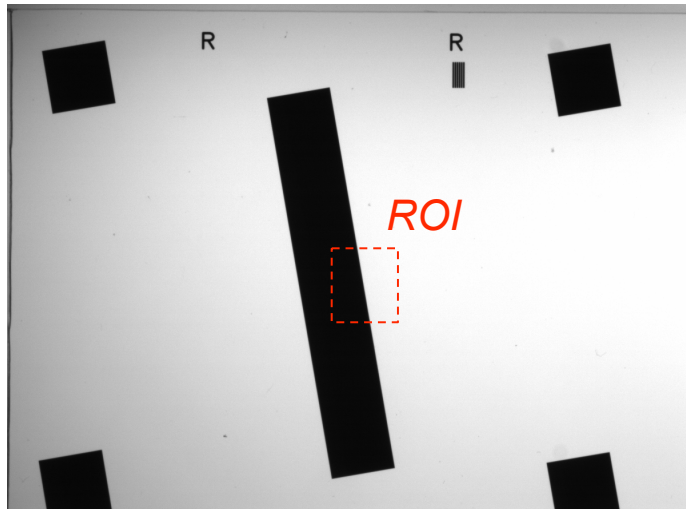

Slant Edge Target

This approach measures MTF using the slant edge target then converts it to CTF

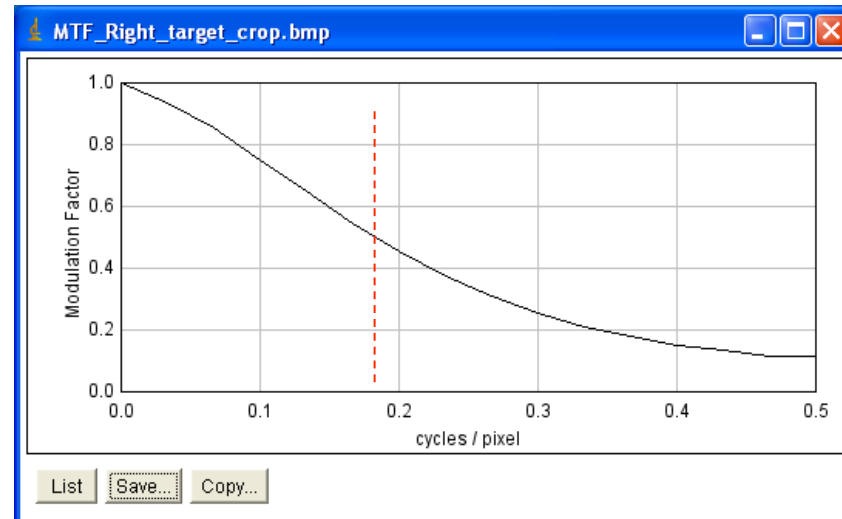

ImageJ MTF Plot

$$\frac{4 \text{ cycles}}{\text{mm}} \times \frac{1 \text{ mm}}{22.2 \text{ pixels}} = 0.18 \text{ cycles/pixel}$$

$$\text{At } 0.18 \text{ cycles/pixel } C_{MTF} = 0.51 \text{ or } 51\%$$

$$\text{Equivalent } C_{CTF} \text{ at } 4 \text{ lp/mm} = 0.51 \times 4 / \pi = 0.65 \text{ or } 65\%$$

- **NIST MobileID Best Practices recommends SNR > 36 dB.**
- **Uses a small region of a test target image where:**
 - **Local average of intensity is constant**
 - **No saturation occurs**
- **Use ImageJ histogram function to compute mean (μ) and standard deviation (σ) of pixel intensity within the 16 x 16 block of pixels**
- **Compute signal-to-noise (in dB) as**

$$SNR = 20 \log \frac{\mu}{\sigma}$$

- **For Appendix F, μ and σ are measured in 0.25 x 0.25 in. areas for a bright image and a dark image and SNR's are calculated for each square as**

$$SNR_{dark} = \frac{\mu_{brt} - \mu_{dark}}{\sigma_{brt}} \quad \text{and} \quad SNR_{brt} = \frac{\mu_{brt} - \mu_{dark}}{\sigma_{dark}}$$

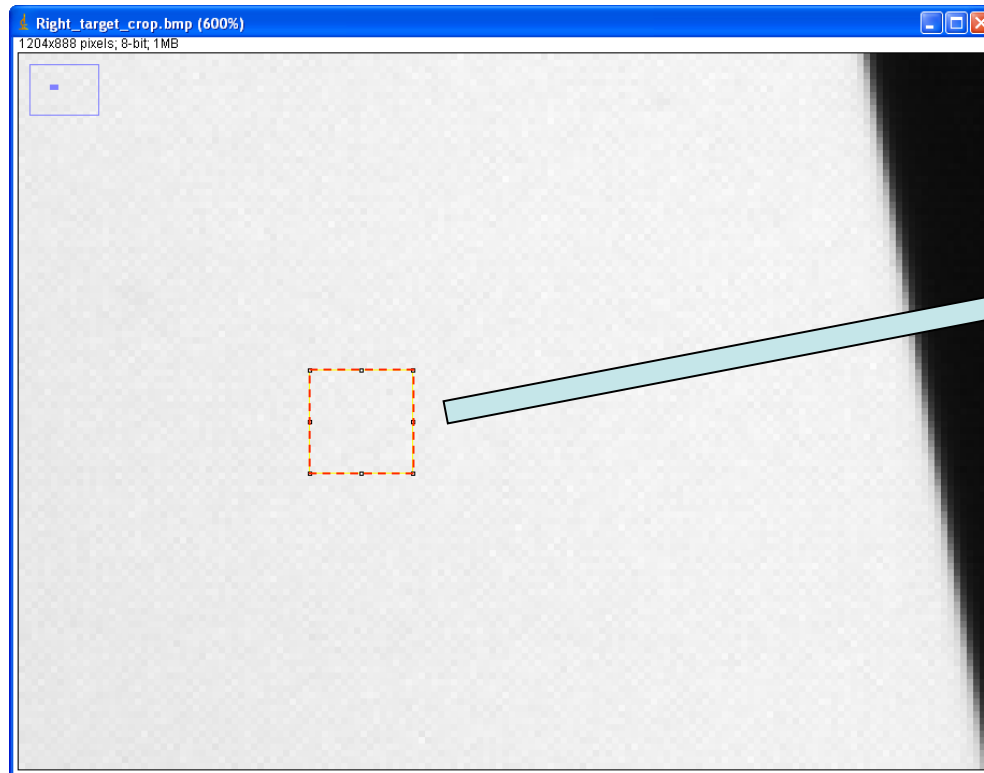

Portion of image of slant edge target with 16 x 16 pixel sample window

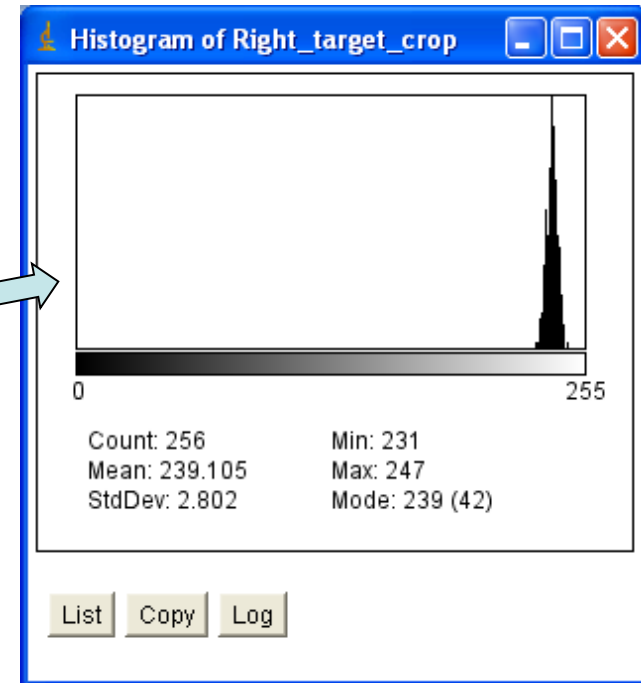

Histogram of sample window

$$\begin{aligned}
 SNR &= 20 \log \frac{239.105}{2.802} \\
 &= 38.6 \text{ db}
 \end{aligned}$$

Test fixture for automated testing of MTF, SNR, pixel resolution and frame rate



Back-illuminated test target is used to obtain highly uniform intensity for SNR measurement (camera LEDs are turned off)



Parameter	Left	Right	Criteria
Modulation	66.79	65.97	<--(Modulation > 60)
SNR	40.77	39.36	<--(SNR > 38)
Frame rate	7	7	<--(Frames/sec)
Spatial resolution	21.85	22.24	<--(Pixels/mm)
Peak Focus	239	241	

Automatic Test System is designed to measure camera parameters that are most likely to be affected by manufacturing errors, shipping damage, contamination, or improper software configuration

Automated test program measures (for each camera):

- 1. Optical resolution (Modulation)*
- 2. Signal-to-noise ratio (SNR)*
- 3. Frame rate (Frames/sec)*
- 4. Spatial resolution (Pixels/mm)*

- **Some specifications impose limits on frame rate and exposure time to assure timely operator feedback and minimize motion blur, particularly for mobile devices.**
- **A method was developed to measure these parameters without access to internal hardware or software design data, operating parameters, etc. other than the sensor scan time for a single line. An upper limit on line time can be estimated as $1/(\text{frame rate} * \text{image height})$.**
- **Method is appropriate for CMOS cameras with rolling shutter in which only a subset of the pixel lines are exposed at any one time.**

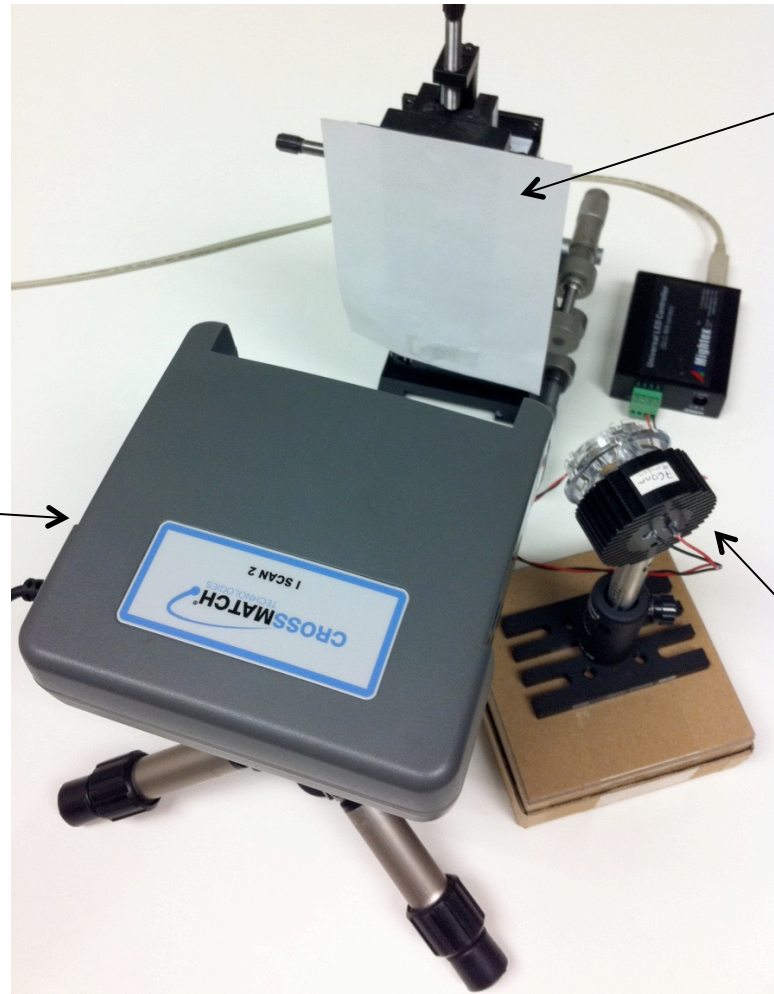

White screen

*Camera – internal
LEDs turned off*

Pulsed LED source - < 1ms



*Pulse rate 7.2 Hz => 7.2 frames/sec
Height of bright bar is 240 lines – the number of lines that are exposed during the 1 ms illumination pulse.*

Line time = 0.12667 msec so

Exposure = 240 x 0.12667 – 1.0 = 29.4 msec



Pulse rate 14.4 Hz - presence of two stationary bright bars means that this is twice the frame rate, confirming that 7.2 fps is correct frame rate.

- **Laser safety standard IEC 60825 has been revised to delete LED safety content**
- **IEC 62471 is a lamp safety standard that was updated in 2006 to cover LED illumination**
- **Standard contains weighted radiance functions that account for dependence on wavelength of retinal thermal hazard, infrared radiation hazard, and skin thermal hazard**
- **Calculations are based on measurements from precisely calibrated spectrometers, and are fairly complex**
- **Recommendation is that eye safety tests be conducted by an independent laboratory that specializes in such tests**

- **NIST MobileID Best Practices Report (SP 500-280) states that**
“The camera’s near infrared illuminator(s) must have a controlled spectral content, such that the overall spectral imaging sensitivity, including the sensor characteristics, transfers at least 35% of the power per any 100nm-wide sub-band of the 700-900nm range.”
- **Purpose is to assure reliable operation for all eye colors.**
- **Measurement must be based on tabulated irradiance as a function of wavelength, which can be obtained from a spectrometer that is calibrated using a standard light source**
- **Irradiance data might also be generated as part of the eye safety analysis**

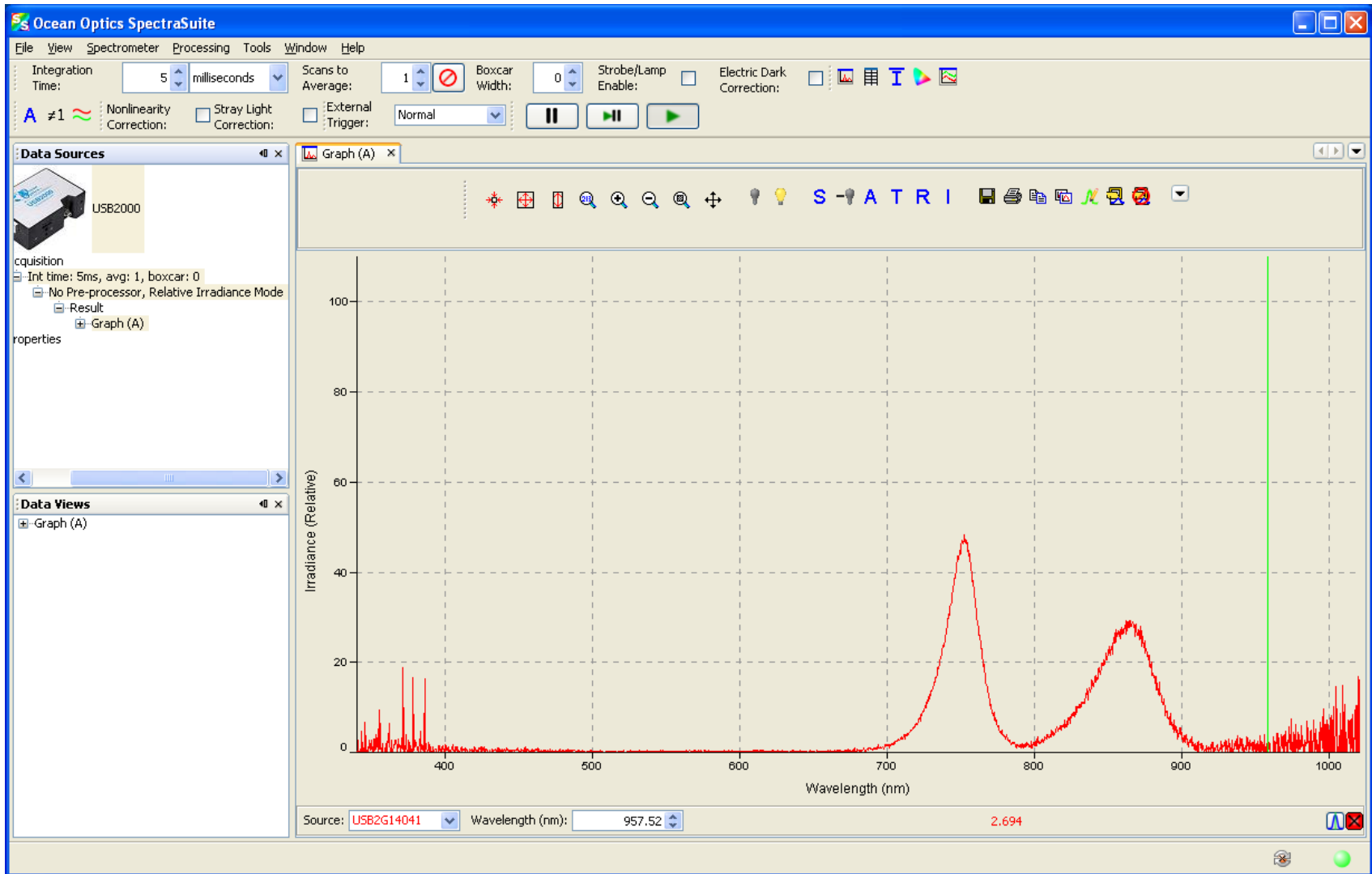

- **Relative spectral data is not generated at regular or integral wavelength values – resample to regular integral values of λ**
- **Correct for spectral response of IR pass filter**
- **Correct for spectral response of image sensor**
- **Calculate integrated spectral power in 100 nm wide bands centered between 750 and 850 nm**

Iscan2 Spectral Distribution

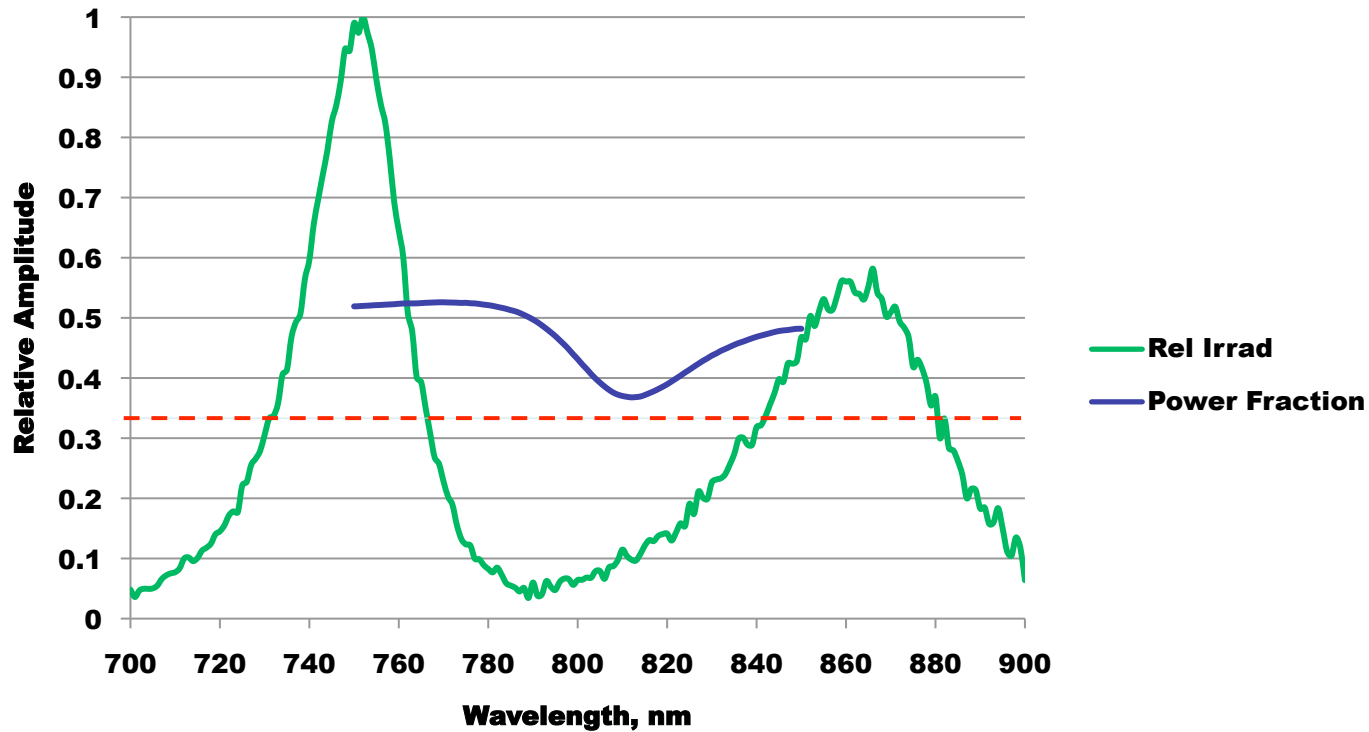

- **Capture volume refers to a 3-dimensional region in which the *center* of the iris must be located in order for capture to occur**
- **The camera field of view must be large enough to accommodate this variation in iris position and still include the entire iris plus the image margins (0.5 x iris diameter left and right and 0.25 x iris diameter above and below by current specification)**
- **The camera depth of field must be sufficient to capture usable iris images across the depth of the capture volume**

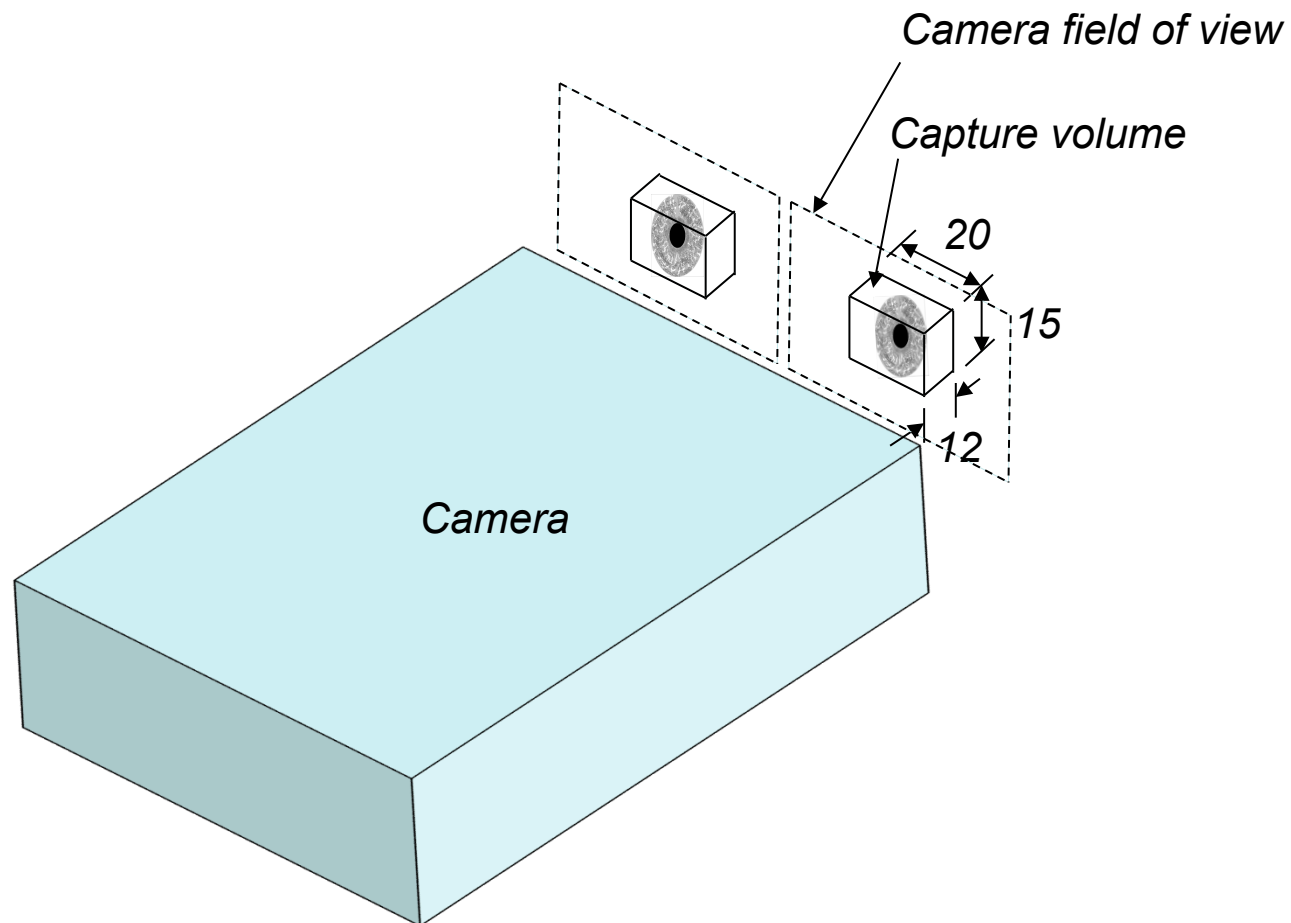

Capture Volume Test Fixture

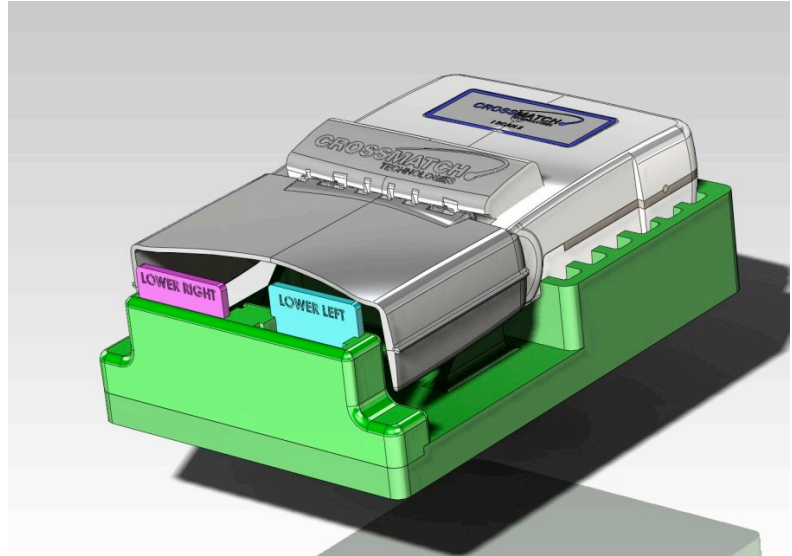
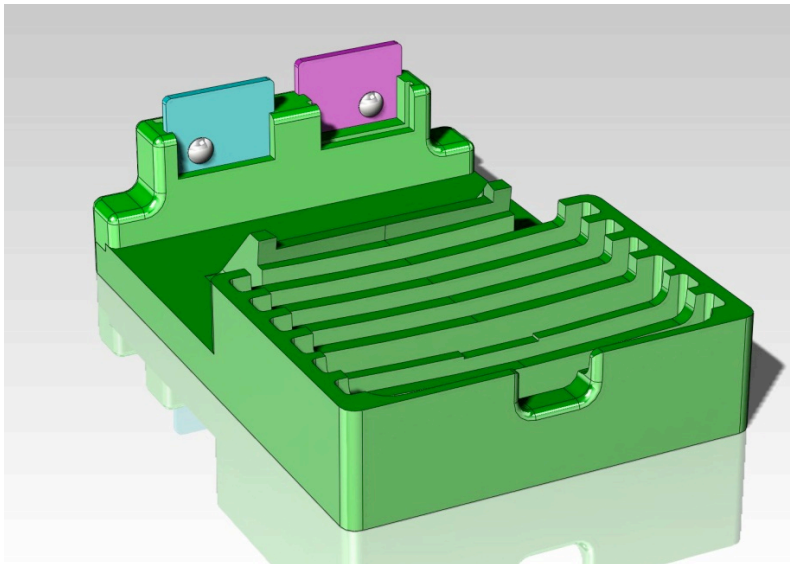

Test Requirement	IScan2 Method	Generic Method
Spatial Resolution	Auto test appl	Test target and ImageJ
Pixel Resolution	Auto test appl	Test target and ImageJ
Signal-to-Noise Ratio	Auto test appl	Test target and ImageJ
Exposure & Frame rate	Test fixture	Test fixture
Eye safety	3rd party test	3rd party test
Spectral distribution	Calibrated Spectrometer	Calibrated Spectrometer
Capture volume	Test fixture	Test fixture



CROSSMATCH[®]
TECHNOLOGIES

Protecting People, Property and Privacy

Thank you!

James L. Cambier Ph.D.
VP & CTO, Iris Technology
james.cambier@crossmatch.com
+1 (561)626-7531