



NIST
National Institute of
Standards and Technology
U.S. Department of Commerce

Report of the 98th National Conference on Weights and Measures

as adopted by the 98th
National Conference on Weights and Measures
2013

NIST Special
Publication **1171**

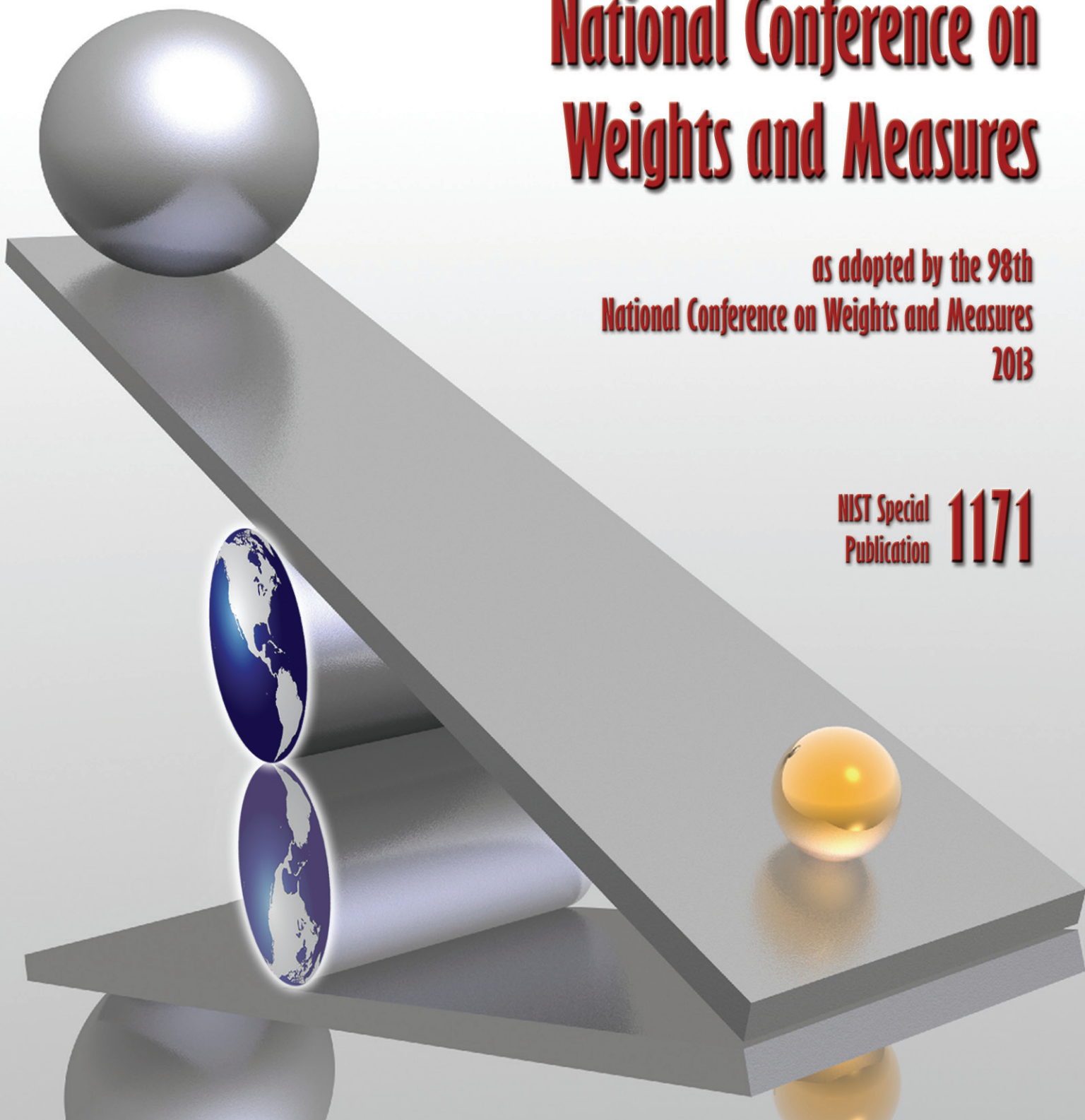

NIST Technical Publications

Periodical

Journal of Research of the National Institute of Standards and Technology—Reports NIST research and development in metrology and related fields of physical science, engineering, applied mathematics, statistics, biotechnology, and information technology. Papers cover a broad range of subjects, with major emphasis on measurement methodology and the basic technology underlying standardization. Also included from time to time are survey articles on topics closely related to the Institute's technical and scientific programs. Issued six times a year.

Nonperiodicals

Monographs—Major contributions to the technical literature on various subjects related to the Institute's scientific and technical activities.

Handbooks—Recommended codes of engineering and industrial practice (including safety codes) developed in cooperation with interested industries, professional organizations, and regulatory bodies.

Special Publications—Include proceedings of conferences sponsored by NIST, NIST annual reports, and other special publications appropriate to this grouping such as wall charts, pocket cards, and bibliographies.

National Standard Reference Data Series—Provides quantitative data on the physical and chemical properties of materials, compiled from the world's literature and critically evaluated. Developed under a worldwide program coordinated by NIST under the authority of the National Standard Data Act (Public Law 90-396). NOTE: The Journal of Physical and Chemical Reference Data (JPCRD) is published bimonthly for NIST by the American Institute of Physics (AIP). Subscription orders and renewals are available from AIP, P.O. Box 503284, St. Louis, MO 63150-3284.

National Construction Safety Team Act Reports—This series comprises the reports of investigations carried out under Public Law 107-231, the technical cause(s) of the building failure investigated; any technical recommendations for changes to or the establishment of evacuation and emergency response procedures; any recommended specific improvements to building standards, codes, and practices; and recommendations for research and other appropriate actions to help prevent future building failures.

Building Science Series—Disseminates technical information developed at the Institute on building materials, components, systems, and whole structures. The series presents research results, test methods, and performance criteria related to the structural and environmental functions and the durability and safety characteristics of building elements and systems.

Technical Notes—Studies or reports which are complete in themselves but restrictive in their treatment of a subject. Analogous to monographs but not so comprehensive in scope or definitive in treatment of the subject area. Often serve as a vehicle for final reports of work performed at NIST under the sponsorship of other government agencies.

Voluntary Product Standards—Developed under procedures published by the Department of Commerce in Part 10, Title 15, of the Code of Federal Regulations. The standards establish nationally recognized requirements for products, and provide all concerned interests with a basis for common understanding of the characteristics of the products. NIST administers this program in support of the efforts of private-sector standardizing organizations.

Order the **following** NIST publications—*FIPS and NISTIRs*—from the National Technical Information Service, Springfield, VA 22161.

Federal Information Processing Standards Publications (FIPS PUB)—Publications in this series collectively constitute the Federal Information Processing Standards Register. The Register serves as the official source of information in the Federal Government regarding standards issued by NIST pursuant to the Federal Property and Administrative Services Act of 1949 as amended, Public Law 89-306 (79 Stat. 1127), and as implemented by Executive Order 11717 (38 FR 12315, dated May 11, 1973) and Part 6 of Title 15 CFR (Code of Federal Regulations).

NIST Interagency or Internal Reports (NISTIR)—The series includes interim or final reports on work performed by NIST for outside sponsors (both government and nongovernment). In general, initial distribution is handled by the sponsor; public distribution is handled by sales through the National Technical Information Service, Springfield, VA 22161, in hard copy, electronic media, or microfiche form. NISTIR's may also report results of NIST projects of transitory or limited interest, including those that will be published subsequently in more comprehensive form.

NIST Special Publication 1171

Report of the 98th National Conference on Weights and Measures



Louisville, Kentucky – July 14 through 18, 2013
as adopted by the 98th National Conference on Weights and Measures 2013

Editors:

Tina Butcher
Linda Crown
Richard Harshman
David Sefcik
Lisa Warfield

Carol Hockett, Chief
Office of Weights and Measures
Physical Measurement Laboratory

<http://dx.doi.org/10.6028/NIST.SP.1171>

March 2014



U.S. Department of Commerce
Penny Pritzker, Secretary

National Institute of Standards and Technology
Patrick D. Gallagher, Under Secretary of Commerce for Standards and Technology and Director

The National Conference on Weights and Measures is supported by the National Institute of Standards and Technology and is attended by officials from various states, counties, and cities, as well as representatives from the U.S. Government, other nations, industry, and consumer organizations.

Certain commercial entities, equipment, or materials may be identified in this document in order to describe an experimental procedure or concept adequately. Such identification is not intended to imply recommendation or endorsement by the National Institute of Standards and Technology, nor is it intended to imply that the entities, materials, or equipment are necessarily the best available for the purpose.

Abstract

The 98th Annual Meeting of the National Conference on Weights and Measures (NCWM) was held July 14 -18, 2013, at the Seelbach Hilton Louisville, Louisville, Kentucky. The theme of the meeting was “On the Path to Tomorrow.”

Reports by the NCWM Board of Directors, Standing Committees, and Special Purpose Committees constitute the major portion of this publication, along with the addresses delivered by Conference officials and other authorities from government and industry.

Special meetings included those of the Scale Manufacturers Association, Meter Manufacturers Association, Packaging and Labeling Subcommittee, Task Group on Printer Ink and Toner Cartridges, Fuels and Lubricants Subcommittee, Associate Membership Committee, Taximeter Technology Advancements, and Making Sense of Electronic Receipts.

Key words: laws and regulations; legal metrology; meters; scales; specifications and tolerances; training; type evaluation; uniform laws; weights and measures.

Note: The policy of the National Institute of Standards and Technology is to use metric units of measurement in all of its publications. In this publication, however, recommendations received by the NCWM technical committees have been printed as they were submitted and, therefore, may contain references to inch-pound units where such units are commonly used in industry practice. Opinions expressed in non-NIST papers are those of the authors and not necessarily those of the National Institute of Standards and Technology. Non-NIST speakers are solely responsible for the content and quality of their material.

National Institute of Standards and Technology Special Publication 1171
Natl. Inst. Stand. Technol. Spec. Pub.1171, 596 pages (March 2014)
<http://dx.doi.org/10.6028/NIST.SP.1171>
CODEN: NSPUE2

National Conference on Weights and Measures

Annual Report of the 98th NCWM

Table of Contents

	Page
Abstract	ii
Past Chairman.....	v
Organizational Chart.....	ix

General Session

President’s Address – Dr. Willie May, NIST, Associate Director of Laboratory Programs/Principal Deputy ...	GEN-1
Chairman’s Address – Stephen Benjamin, North Carolina	GEN-23
Chairman Elect’s Address – John Gaccione, Westchester County, New York	GEN-25
Awards and Recognition	
Contribution Award	GEN-29
Distinguished Service Award Recipients.....	GEN-29
Lifetime Achievement Award.....	GEN-29
Attendance Recognitions	GEN-29

Standing Committee Reports

Board of Directors (BOD)..... BOD-1

Appendix A. Report of the Activities of the International Organization of Legal Metrology (OIML) and Regional Legal Metrology Organizations	BOD-A1
Appendix B. Associate Membership Committee (AMC) Agenda and Draft Meeting Minutes.....	BOD-B1

Laws and Regulations Committee (L&R)L&R-1

Appendix A. Item 231-2: NIST Handbook 130, Uniform Packaging and Labeling Regulation Section: 10.3. Aerosols and Similar Pressurized Containers	L&R-A1
Appendix B. Item 232-1: NIST Handbook 130, Uniform Engine Fuels and Automotive Lubricants Regulation, Section 1. Definitions of “Diesel Liter Equivalent (DLE) and Diesel Gallon Equivalent (DGE)”;	
and Item 237-4: NIST Handbook 130, : NIST Handbook 130, Uniform Engine Fuels and Automotive Lubricants Regulation, Sections 3.13. Oil, 3.13.1.4. Engine Service Category, 3.33.1.4.1. Vehicle or Engine Manufacturer Standard, and 3.13.1.4.2. Inactive or Obsolete Service Categories	L&R-B1
Appendix C. Item 232-2: NIST Handbook 130, Uniform Method of Sale of Commodities, Sections 2.33. Oil, 2.33.1.4. Engine Service Category, 2.33.1.4.1. Vehicle or Engine Manufacturer Standards, and 2.33.1.4.2. Inactive or Obsolete Service Category; and	

	Item 237-4:	NIST Handbook 130, Uniform Engine Fuels and Automotive Lubricants Regulation, Sections 3.13. Oil, 3.13.1.4. Engine Service Category, 3.33.1.4.1. Vehicle or Engine Manufacturer Standard, and 3.13.1.4.2. Inactive or Obsolete Service Categories	L&R-C1
Appendix D.	Item 232-5:	NIST Handbook 130, Uniform Method of Sale of Commodities, Section 2.XX. Retail Sale of Electricity/Vehicle.....	L&R-D1
Appendix E.	Item 237-2:	NIST Handbook 130, Uniform Engine Fuels and Automotive Lubricants Regulation, NIST Handbook 130, Uniform Method of Sale of Commodities, Section 2.XX. Retail Sale of Electricity/Vehicle.....	L&R-E1
Appendix F.	Item 260-4:	NIST Handbook 133, Section 4.3. Paper Plates and Sanitary Paper Products	L&R-F1
Appendix G.	Item 237-8:	NIST Handbook 130, Uniform Engine Fuels and Automotive Lubricants Regulation, 4.3. Dispenser Filters.....	L&R-G1
Specifications and Tolerances Committee (S&T)			S&T-1
Appendix A.	Item 337-1 and 337-2:	NIST Handbook 44, Background and Justification for Handbook 44 Definition of “Diesel Gallon Equivalent (DGE)” or Natural Gas as a Vehicular Fuel Approval	
	Item 320-6:	NIST Handbook 44, Appendix D – Definitions (Reference Weigh Car).....	S&T-A1
Appendix B.	Item 336-1:	NIST Handbook 44, Draft Tentative Code Applicable to Weigh-In-Motion Systems Used for Vehicle Enforcement Screening and proposed definitions to be added to NIST Handbook 44, Appendix D to support the Weigh-In-Motion Systems used for Vehicle Enforcement Screening – Draft Code	S&T-B1
Professional Development Committee (PDC)			PDC-1
Appendix A.	Professional Certification Program Curriculum Work Plan.....		PDC-A1
Appendix B.	History of Professional Certification Program.....		PDC-B1
Appendix C.	History of Instructor Improvement		PDC-C1
National Type Evaluation Program Committee (NTEP)			NTEP-1
Appendix A.	NTEP Statistics Report		NTEP-A1
Appendix B.	Belt-Conveyor Scale Meeting Summary		NTEP- B1
Appendix C.	NTETC Grain Analyzer Sector Meeting Summary		NTEP-C1
Appendix D.	NTETC Measuring Sector Meeting Summary.....		NTEP-D1
Appendix E.	NTETC Software Sector Meeting Summary		NTEP-E1
Appendix F.	NTETC Weighing Sector Meeting Summary		NTEP-F1
Nominating Committee			NOM-1
Attendees			ATTEND-1

Past Chairmen of the Conference

Conference	Year	Location	Chairman
1 st	1905	Washington, D.C.	Dr. S. W. Stratton, Bureau of Standards
2 nd	1906	Washington, D.C.	Dr. S. W. Stratton, Bureau of Standards
3 rd	1907	Washington, D.C.	Dr. S. W. Stratton, Bureau of Standards
4 th	1908	Washington, D.C.	Dr. S. W. Stratton, Bureau of Standards
	1909	Conference Not Held	
5 th	1910	Washington, D.C.	Dr. S. W. Stratton, Bureau of Standards
6 th	1911	Washington, D.C.	Dr. S. W. Stratton, Bureau of Standards
7 th	1912	Washington, D.C.	Dr. S. W. Stratton, Bureau of Standards
8 th	1913	Washington, D.C.	Dr. S. W. Stratton, Bureau of Standards
9 th	1914	Washington, D.C.	Dr. S. W. Stratton, Bureau of Standards
10 th	1915	Washington, D.C.	Dr. S. W. Stratton, Bureau of Standards
11 th	1916	Washington, D.C.	Dr. S. W. Stratton, Bureau of Standards
	1917	Conference Not Held	
	1918	Conference Not Held	
12 th	1920	Washington, D.C.	Dr. S. W. Stratton, Bureau of Standards
13 th	1921	Washington, D.C.	Dr. S. W. Stratton, Bureau of Standards
14 th	1922	Washington, D.C.	Dr. S. W. Stratton, Bureau of Standards
15 th	1923	Washington, D.C.	Dr. George Burgess, Bureau of Standards
16 th	1924	Washington, D.C.	Dr. George Burgess, Bureau of Standards
17 th	1925	Washington, D.C.	Dr. George Burgess, Bureau of Standards
18 th	1926	Washington, D.C.	Dr. George Burgess, Bureau of Standards
19 th	1927	Washington, D.C.	Dr. George Burgess, Bureau of Standards
20 th	1928	Washington, D.C.	Dr. George Burgess, Bureau of Standards
21 st	1928	Washington, D.C.	Dr. George Burgess, Bureau of Standards
22 nd	1929	Washington, D.C.	Dr. George Burgess, Bureau of Standards
23 rd	1930	Washington, D.C.	Dr. George Burgess, Bureau of Standards
24 th	1931	Washington, D.C.	Dr. George Burgess, Bureau of Standards
	1932	Conference Not Held	
	1933	Conference Not Held	
	1934	Conference Not Held	
25 th	1935	Washington, D.C.	Dr. Lyman Briggs, National Bureau of Standards
26 th	1936	Washington, D.C.	Dr. Lyman Briggs, National Bureau of Standards
27 th	1937	Washington, D.C.	Dr. Lyman Briggs, National Bureau of Standards
28 th	1938	Washington, D.C.	Dr. Lyman Briggs, National Bureau of Standards

Conference	Year	Location	Chairman
29 th	1939	Washington, D.C.	Dr. Lyman Briggs, National Bureau of Standards
30 th	1940	Washington, D.C.	Dr. Lyman Briggs, National Bureau of Standards
31 st	1941	Washington, D.C.	Dr. Lyman Briggs, National Bureau of Standards
	1942	Conference Not Held	
	1943	Conference Not Held	
	1944	Conference Not Held	
	1945	Conference Not Held	
32 nd	1946	Washington, D.C.	Dr. E. U. Condon, National Bureau of Standards
33 rd	1947	Washington, D.C.	Dr. E. U. Condon, National Bureau of Standards
	1948	Conference Not Held	
34 th	1949	Washington, D.C.	Dr. E. U. Condon, National Bureau of Standards
35 th	1950	Washington, D.C.	Dr. E. U. Condon, National Bureau of Standards
36 th	1951	Washington, D.C.	Dr. E. U. Condon, National Bureau of Standards
37 th	1952	Washington, D.C.	Dr. E. U. Condon, National Bureau of Standards
38 th	1953	Washington, D.C.	Dr. E. U. Condon, National Bureau of Standards
39 th	1954	Washington, D.C.	Dr. E. U. Condon, National Bureau of Standards
40 th	1955	Washington, D.C.	Dr. E. U. Condon, National Bureau of Standards
41 st	1956	Washington, D.C.	Dr. A. V. Astin, National Bureau of Standards
42 nd	1957	Washington, D.C.	Dr. A. V. Astin, National Bureau of Standards
43 rd	1958	Washington, D.C.	J. P. McBride, MA
44 th	1959	Washington, D.C.	C. M. Fuller, CA
45 th	1960	Washington, D.C.	H. E. Crawford, FL
46 th	1961	Washington, D.C.	R. E. Meek, IN
47 th	1962	Washington, D.C.	R. Williams, NY
48 th	1963	Washington, D.C.	C. H. Stender, SC
49 th	1964	Washington, D.C.	D. M. Turnbull, WA
50 th	1965	Washington, D.C.	V. D. Campbell, OH
51 st	1966	Denver, CO	J. F. True, KS
52 nd	1967	Washington, D.C.	J. E. Bowen, MA
53 rd	1968	Washington, D.C.	C. C. Morgan, IN
54 th	1969	Washington, D.C.	S. H. Christie, NJ
55 th	1970	Salt Lake City, UT	R. W. Searles, OH
56 th	1971	Washington, D.C.	M. Jennings, TN
57 th	1972	Washington, D.C.	E. H. Black, CA
58 th	1973	Minneapolis, MN	G. Johnson, KY
59 th	1974	Washington, D.C.	J. Lewis, WA
60 th	1975	San Diego, CA	S. Andrews, FL

Conference	Year	Location	Chairman
61 st	1976	Washington, D.C.	R. Thompson, MD
62 nd	1977	Dallas, TX	E. Prideaux, CO
63 rd	1978	Washington, D.C.	J. Lyles, WA
64 th	1979	Portland, OR	K. Simila, OR
65 th	1980	Washington, D.C.	C. Vincent, TX
66 th	1981	St. Louis, MO	E. Stadolnik, MA
67 th	1982	Atlanta, GA	E. Heffron, MI
68 th	1983	Sacramento, CA	C. Greene, NM
69 th	1984	Boston, MA	S. Hindsman, AR
70 th	1985	Washington, D.C.	E. Delfino, CA
71 st	1986	Albuquerque, NM	G. Mattimoe, HI
72 nd	1987	Little Rock, AR	F. Nagele, MI
73 rd	1988	Grand Rapids, MI	D. Guensler, CA
74 th	1989	Seattle, WA	J. Bartfai, NY
75 th	1990	Washington, D.C.	F. Gerck, NM
76 th	1991	Philadelphia, PA	N. D. Smith, NC
77 th	1992	Nashville, TN	S. Colbrook, IL
78 th	1993	Kansas City, MO	A. Nelson, CT
79 th	1994	San Diego, CA	T. Geiler, MA
80 th	1995	Portland, ME	J. Truex, OH
81 st	1996	New Orleans, LA	C. Gardner, NY
82 nd	1997	Chicago, IL	B. Bloch, CA
83 rd	1998	Portland, OR	S. Malone, NE
84 th	1999	Burlington, VT	A. Thompson, AK
85 th	2000	Richmond, VA	W. Diggs, VA
86 th	2001	Washington, D.C.	L. Straub, MD
87 th	2002	Cincinnati, OH	R. Murdock, NC
88 th	2003	Sparks, NV	R. Andersen, NY
89 th	2004	Pittsburgh, PA	D. Ehrhart, AZ
90 th	2005	Orlando, FL	W. Diggs, VA
91 st	2006	Chicago, IL	D. Onwiler, NE
92 nd	2007	Salt Lake City, UT	M. Cleary, CA
93 rd	2008	Burlington, VT	J. Cardin, WI
94 th	2009	San Antonio, TX	J. Kane, MT
95 th	2010	St. Paul, MN	R. Jennings, TN
96 th	2011	Missoula, MT	T. Tyson, KS
97 th	2012	Portland, ME	K. Floren, CA

Past Chairmen – 2013 Final Report

Conference	Year	Location	Chairman
98 th	2013	Louisville, KY	S. Benjamin, NC

2012 – 2013 Organizational Chart

NCWM Board of Directors			
OFFICE	NAME	AFFILIATION	TERM ENDS
Chairman	Stephen Benjamin	North Carolina	2013
Chairman-Elect	John Gaccione	Westchester County, New York	2013
NTEP Committee Chair	Kurt Floren	Los Angeles County, California	2013
Treasurer	Mark Coyne	City of Brockton, Massachusetts	2013
Active Membership – Western	Jerry Buendel	Washington	2017
Active Membership – Central	Ronald Hayes	Missouri	2015
Active Membership – Southern	Terence McBride	Memphis, Tennessee	2013
Active Membership – Northeastern	James Cassidy	City of Cambridge, Massachusetts	2014
At-Large	Stephen Langford	Cardinal Scale Manufacturing, Co.	2013
At-Large	Steve Giguere	Maine	2016
Associate Membership	Gordon Johnson	Gilbarco, Inc.	2013
Honorary NCWM President	Dr. Patrick D. Gallagher	NIST Director	NA
Executive Secretary	Carol Hockert	NIST, Office of Weights and Measures	NA
Executive Director	Don Onwiler	NCWM	NA
Board of Directors Advisor	Gilles Vinet	Measurement Canada	NA
NTEP Administrator	Jim Truex	NCWM	NA
National Type Evaluation Program Committee (NTEP)			
OFFICE	NAME	AFFILIATION	TERM ENDS
Committee Chair	Kurt Floren	Los Angeles County, California	2013
Member	Stephen Benjamin	North Carolina	2014
Member	John Gaccione	Westchester County, New York	2015
Member	Ronald Hayes	Missouri	2015
Member	James Cassidy	Massachusetts	2016
NTEP Administrator	Jim Truex	NCWM Headquarters	NA
Finance Committee			
OFFICE	NAME	AFFILIATION	TERM ENDS
Committee Chair	John Gaccione	Westchester County, New York	2013
Member	Mark Coyne	City of Brockton, Massachusetts	2013

Organizational Chart – 2013 Final Report

Member	Ron Hayes	Missouri	2014
Member	Gordon Johnson	Gilbarco, Inc.	2013
Executive Director	Don Onwiler	NCWM Headquarters	NA

Laws and Regulations Committee (L&R)

OFFICE	NAME	AFFILIATION	TERM ENDS
Committee Chair	Judy Cardin	Wisconsin	2013
Member	Raymond Johnson	New Mexico	2014
Member	Tim Lloyd	Montana	2015
Member	Richard Lewis	Georgia	2016
Member	Louis Sakin	Towns of Hopkinton/Northbridge, Massachusetts	2017
Associate Membership Representative	Rob Underwood	Petroleum Marketers Association of America	2013
Canadian Technical Advisor	Lance Robertson	Measurement Canada	NA
NIST Technical Advisor	David Sefcik	NIST, Office of Weights and Measures	NA
NIST Technical Advisor	Lisa Warfield	NIST, Office of Weights and Measures	NA

Professional Development Committee (PDC)

OFFICE	NAME	AFFILIATION	TERM ENDS
Committee Chair	Julie Quinn	Minnesota	2013
Member	Dale Saunders	Virginia	2014
Member	Cheryl Ayer	New Hampshire	2015
Member	Kristin Macey	California	2016
Member	Stacy Carlsen	Marin County, California	2017
Associate Membership Representative	Steven Grabski	Walmart Stores, Inc.	2013
Safety Liaison	TBD		NA
NIST Technical Advisor	TBD		NA
Certification Coordinator	Ross Andersen		NA

Specifications and Tolerances Committee (S&T)

OFFICE	NAME	AFFILIATION	TERM ENDS
Committee Chair	Kenneth Ramsburg	Maryland	2013
Member	Paul Moyer	Nebraska	2014
Member	Brett Gurney	Utah	2015
Member	Mahesh Albuquerque	Colorado	2016

Member	Jane Zulkiewicz	Town of Barnstable	2017
Canadian Technical Advisor	Luciano Burtini	Measurement Canada	NA
NIST Technical Advisor	Tina Butcher	NIST, Office of Weights and Measures	NA
NIST Technical Advisor	Rick Harshman	NIST, Office of Weights and Measures	NA

Nominating Committee

OFFICE	NAME	AFFILIATION	TERM ENDS
Committee Chair	Kurt Floren	Los Angeles County, California	2013
Member	Judy Cardin	Wisconsin	2013
Member	Thomas Geiler	Barnstable, Massachusetts	2013
Member	Joe Gomez	New Mexico	2013
Member	Maxwell Gray	Florida	2013
Member	Randy Jennings	Tennessee	2013
Member	Tim Tyson	Kansas	2013

Credentials Committee

OFFICE	NAME	AFFILIATION	TERM ENDS
Committee Chair	Brett Saum	San Luis Obispo County, California	2013
Member	Craig VanBuren	Michigan	2014
Member	Jerry Butler	North Carolina	2015
Coordinator	Thomas Geiler	Barnstable, Massachusetts	2013

Appointive Officials			
OFFICE	NAME	AFFILIATION	TERM ENDS
Chaplain	Stephen Langford	Cardinal Scale Manufacturing, Co.	2013
Parliamentarian	Louis Straub	Fairbanks Scale, Inc.	2013
Presiding Officer	John Albert	Missouri	2013
Presiding Officer	Jack Walsh	Town of Wellesley	2013
Presiding Officer	Tim Chesser	Arkansas Bureau of Standards	2013
Presiding Officer	Angela Godwin	Ventura County, California	2013
Sergeants-at-Arms	John Cook	Kentucky	2013
Sergeants-at-Arms	Chester Watson	Kentucky	2013

Associate Membership Committee			
OFFICE	NAME	AFFILIATION	TERM ENDS
Chair	Robert Murnane, Jr.	Seraphin Test Measure	2013
Vice Chair	Paul A. Lewis, Sr.	Rice Lake Weighing Systems, Inc.	2013
Secretary/Treasurer	Darrell Flocken	Mettler-Toledo, Inc.	2013
Member	Darrell Flocken	Mettler-Toledo, Inc.	2013
Member	Michael Gaspers	Farmland Foods, Inc.	2013
Member	Paul A. Lewis, Sr.	Rice Lake Weighing Systems, Inc.	2014
Member	Robert Murnane, Jr.	Seraphin Test Measure	2014
Member	Steven Grabski	Walmart Stores, Inc.	2015
Member	Christopher Guay	Procter and Gamble, Co.	2015
Member	Thomas McGee	PMP Corporation	2015
Member	Rob Underwood	Petroleum Marketers Association of America	2015
Member	Pete O'Bryan	Foster Farms	2016

Fuels and Lubricants Subcommittee		
OFFICE	NAME	AFFILIATION
Chair	Ronald Hayes	Missouri
NIST Technical Advisor	Kenneth Butcher	NIST, Office of Weights and Measures
NIST Technical Advisor	David Sefcik	NIST, Office of Weights and Measures
Public Sector Member	Mahesh Albuquerque	Colorado
Public Sector Member	Stephen Benjamin	North Carolina
Public Sector Member	Matthew Curran	Florida
Public Sector Member	Steven Harrington	Minnesota
Public Sector Member	Randy Jennings	Tennessee
Public Sector Member	Kristin Macey	California
Public Sector Member	William Spitzley	Michigan
Private Sector Member	Chuck Corr	Archer Daniels Midland Company
Private Sector Member	Kevin Ferrick	API
Private Sector Member	K.W. Gardner	ExxonMobil Corporation
Private Sector Member	Bill Geubelle	Conoco Phillips
Private Sector Member	Philip Guillemette	Flint Hills Resources, LP
Private Sector Member	John Harkins	Sunoco, Inc.
Private Sector Member	Marilyn Herman	Herman and Associates
Private Sector Member	Jerome Horn	Chevron Global Downstream, LLC
Private Sector Member	Patrick Kelly	API
Private Sector Member	R. Scotti Lee	Automotive Oil Change Association
Private Sector Member	Roger Leisenring, Jr.	KiOR
Private Sector Member	Russ Lewis	Marathon Petroleum, LLC
Private Sector Member	James McGetrick	BP Products
Private Sector Member	Kristin Moore	Renewable Fuels Association
Private Sector Member	Robert Nelson	Shell Oil Products
Private Sector Member	Manuch Nikanjam	Chevron Global Downstream, LLC
Private Sector Member	Keith Penn	Colonial Pipeline Company
Private Sector Member	Derek Regal	Tesoro Companies, Inc.
Private Sector Member	Robert Reynolds	Downstream Alternatives, Inc.
Private Sector Member	Rebecca Richardson	MARC IV Consulting
Private Sector Member	Prentiss Searles	American Petroleum Institute
Private Sector Member	Shane Skelton	American Petroleum Institute
Private Sector Member	Curtis Williams	CP Williams Energy Consulting, LLC
Private Sector Member	William Woebkenberg	Mercedes-Benz Research and Development NA

Packaging and Labeling Subcommittee

OFFICE	NAME	AFFILIATION
Chair	Christopher Guay	Procter and Gamble, Co.
NIST Technical Advisor	David Sefcik	NIST, Office of Weights and Measures
Public Sector Member (CWMA)	Nicholas Owens	Stark County Weights and Measures
Public Sector Member (NEWMA)	Frank Greene	Connecticut
Public Sector Member (SWMA)	Bill Tedder	North Carolina
Public Sector Member (WWMA)	Angela Godwin	County of Ventura
Private Sector Member	Krister Hard af Segerstad	IKEA North America Services, LLC
Private Sector Member	Zina Juroch	Pier 1 Imports
Private Sector Member	Pete O’Bryan	Foster Farms
Private Sector Member	Stratt Pinagel	Walmart Stores, Inc.

Natural Gas Steering Committee

OFFICE	NAME	AFFILIATION
Chair	Mahesh Albuquerque	CDLE – Oil and Public Safety
NIST Technical Advisor	Juana Williams	NIST Office of Weights and Measures
L&R Committee Rep.	Judy Cardin	Wisconsin
S&T Committee Rep.	Mahesh Albuquerque	Colorado
Public Sector Member	Douglas Horne	Clean Vehicle Education Foundation

Promotional Tool Kit Task Group

OFFICE	NAME	AFFILIATION
Chair	Stephen Benjamin	North Carolina
Public Sector Member	Kurt Floren	Los Angeles County
Public Sector Member	Jerry Buendel	Washington
Private Sector Member	Henry Oppermann	Weights and Measures Consulting
Private Sector Member	John Hughes	Rice Lake Weighing Systems

Task Group on Retail Motor Fuel Dispenser Price Posting and Computer Capability

OFFICE	NAME	AFFILIATION
Chair	Fran Elson-Houston	Ohio
NIST Technical Advisor	Juana Williams	NIST, Office of Weights and Measures
Public Sector Member	Shelly Miller	Wisconsin
Public Sector Member	Ken Ramsburg	Maryland
Public Sector Member	Jerry Buendel	Washington State Department of Agriculture
Private Sector Member	Rex Brown	Petroleum Equipment Institute
Private Sector Member	John Eichberger	National Association of Convenience Stores
Private Sector Member	Gordon Johnson	Gilbarco, Inc.
Private Sector Member	Phil Katselnik	Dresser Wayne
Private Sector Member	Mike Roach	VeriFone
Private Sector Member	Richard Suiter	Richard Suiter Consulting
Private Sector Member	Rob Underwood	Petroleum Marketers Association of America

Multiple Dimensions Measuring Device Work Group

OFFICE	NAME	AFFILIATION
Chair	Robert Kennington	Quantronix, Inc.
NIST Technical Advisor	TBD	NIST, Office of Weights and Measures
Public Sector Member	Fran Elson-Houston	Ohio
Public Sector Member	Luciano Burtini	Measurement Canada
Public Sector Member	Justin Rae	Measurement Canada
Private Sector Member	Scott Wigginton	United Parcel Service

NTETC Belt-Conveyor Sector

OFFICE	NAME	AFFILIATION
Chair	Bill Ripka	Thermo Fisher Scientific
Technical Advisor	John Barton	NIST, Office of Weights and Measures
NTEP Administrator	Jim Truex	NCWM Headquarters
Public Sector Member	Tina Butcher	NIST, Office of Weights and Measures
Public Sector Member	Ken Jones	California
Private Sector Member	Rafael Jimenez	Association of American Railroads Transportation Technology Center, Inc.
Private Sector Member	Lars Marmsater	Merrick Industries, Inc.
Private Sector Member	Peter Sirrico	Thayer Scale/Hyer Industries
Private Sector Member	Thomas Vormittag	

NTETC Grain Analyzer Sector		
OFFICE	NAME	AFFILIATION
Chair	Cassie Eigenmann	DICKEY-john Corporation
Co-Technical Advisor	Jack Barber	J B Associates
Co-Technical Advisor	G. Diane Lee	NIST, Office of Weights and Measures
NTEP Administrator	Jim Truex	NCWM Headquarters
Public Sector Member	Tina Butcher	NIST, Office of Weights and Measures
Public Sector Member	Karl Cunningham	Illinois
Public Sector Member	Ivan Hankins	Iowa
Public Sector Member	Thomas Hughes	Missouri
Public Sector Member	Richard Pierce	USDA, GIPSA Technical Services Division
Private Sector Member	Jeffrey Adkisson	Grain and Feed Association of Illinois
Private Sector Member	James Bair	North American Miller's Association
Private Sector Member	Rachel Beiswenger	TSI Incorporated
Private Sector Member	Martin Clements	The Steinlite Corporation
Private Sector Member	Andrew Gell	Foss North America
Private Sector Member	Charles Hurburgh, Jr.	Iowa State University
Private Sector Member	Jess McCluer	National Grain and Feed Association
Private Sector Member	Thomas Runyon	Seedbuero Equipment Co.

NTETC Measuring Sector

OFFICE	NAME	AFFILIATION
Chair	Michael Keilty	Endress + Hauser Flowtec AG, USA
Technical Advisor	Marc Buttler	NIST, Office of Weights and Measures
NTEP Administrator	Jim Truex	NCWM Headquarters
Public Sector Member	Dennis Beattie	Measurement Canada
Public Sector Member	Tina Butcher	NIST, Office of Weights and Measures
Public Sector Member	Jerry Butler	North Carolina
Public Sector Member	TBD	Maryland
Public Sector Member	John Roach	California
Private Sector Member	Steve Bar	Bennett Pump Company
Private Sector Member	Rodney Cooper	Tuthill Transfer Systems
Private Sector Member	Constantine Cotsoradis	Flint Hills Resources
Private Sector Member	Paul Glowacki	Murray Equipment, Inc.
Private Sector Member	Gordon Johnson	Gilbarco, Inc.
Private Sector Member	Dmitri Karimov	Liquid Controls
Private Sector Member	Yefim Katselnik	Dresser Wayne
Private Sector Member	Douglas Long	RDM Industrial Electronics
Private Sector Member	Andrew MacAllister	Daniel Measurement and Control
Private Sector Member	Daniel Maslowski	LTS Sales
Private Sector Member	Wade Mattar	Invensys/Foxboro
Private Sector Member	Richard Miller	FMC Technologies Measurement Solutions, Inc.
Private Sector Member	Andre Noel	Neptune Technology Group, Inc.
Private Sector Member	Henry Oppermann	Weights & Measures Consulting, LLC
Private Sector Member	Johnny Parrish	Brodie International
Private Sector Member	Dan Peterson	Yokogawa Corporation of America
Private Sector Member	Richard Tucker	RL Tucker Consulting, LLC

NTETC Software Sector		
OFFICE	NAME	AFFILIATION
Chair	James Pettinato	FMC Technologies Measurement Solutions, Inc.
Technical Advisor	Doug Bliss	Mettler-Toledo, Inc.
Secretary	Teri Gulke	Liquid Controls, LLC
NTEP Administrator	Jim Truex	NCWM Headquarters
Public Sector Member	Dennis Beattie	Measurement Canada
Public Sector Member	Michael Frailer	Maryland
Public Sector Member	Ken Jones	California
Public Sector Member	Joe Morrison	Ohio
Public Sector Member	Eric Morabito	New York
Public Sector Member	Edward Payne	Maryland
Public Sector Member	John Roach	California
Public Sector Member	Zacharias Tripoulas	Maryland
Public Sector Member	Ambler Thompson	NIST, Office of Weights and Measures
Private Sector Member	Mary Abens	Emerson Process Management
Private Sector Member	John Atwood	Tyson Foods
Private Sector Member	Gary Benjamin	NCR Corporation
Private Sector Member	Kevin Detert	Avery Weigh-Tronix
Private Sector Member	Cassie Eigenmann	DICKEY-john Corporation
Private Sector Member	Andre Elle	Endress + Hauser Flowtec AG
Private Sector Member	Andrew Gell	Foss North America
Private Sector Member	Keith Harper	Gencor Industries, Inc.
Private Sector Member	Tony Herrin	Cardinal Scale Manufacturing Co.
Private Sector Member	Paul A. Lewis, Sr.	Rice Lake Weighing Systems, Inc.
Private Sector Member	Rick Lydon	Sick, Inc.
Private Sector Member	Richard Miller	FMC Technologies Measurement Solutions, Inc.
Private Sector Member	Christopher (Adam) Oldham	Gilbarco, Inc.
Private Sector Member	Michael Parks	Vulcan Materials Company
Private Sector Member	Mike Roach	VeriFone
Private Sector Member	Robin Sax	CompuWeigh Corporation
Private Sector Member	David Vande Berg	Vande Berg Scales
Private Sector Member	John Wind	Bizerba USA, Inc.
Private Sector Member	Kraig Wooddell	Hobart

NTETC Weighing Sector

OFFICE	NAME	AFFILIATION
Chair	Darrell Flocken	Mettler-Toledo, Inc.
Technical Advisor	Rick Harshman	NIST, Office of Weights and Measures
NTEP Administrator	Jim Truex	NCWM Headquarters
Public Sector Member	L. Cary Ainsworth	USDA, GIPSA
Public Sector Member	Bryon School	USDA, GIPSA, FGIS
Public Sector Member	Luciano Burtini	Measurement Canada
Public Sector Member	Tina Butcher	NIST, Office of Weights and Measures
Public Sector Member	Fran Elson-Houston	Ohio
Public Sector Member	Ken Jones	California
Public Sector Member	Jack Kane	Montana
Public Sector Member	Edward Payne	Maryland
Public Sector Member	Zacharias Tripoulas	Maryland
Public Sector Member	Tim Tyson	Kansas
Public Sector Member	Juana Williams	NIST, Office of Weights and Measures
Private Sector Member	Steven Beitzel	Systems Associates, Inc.
Private Sector Member	Greg Bredahl	Thermo Fisher Scientific
Private Sector Member	Neil Copley	Thurman Scale Co.
Private Sector Member	Hayden Cornish	Schenck Process
Private Sector Member	Mitchell Eyles	Flintec, Inc.
Private Sector Member	Robert Feezor	Scales Consulting and Testing
Private Sector Member	Scott Henry	Motorola Solutions, Inc.
Private Sector Member	Sam Jalahej	Totalcomp, Inc.
Private Sector Member	Rafael Jimenez	Association of American Railroads Transportation Technology Center, Inc.
Private Sector Member	Stephen Langford	Cardinal Scale Manufacturing, Co.
Private Sector Member	Paul A. Lewis, Sr.	Rice Lake Weighing Systems, Inc.
Private Sector Member	L. Edward Luthy	Stock Equipment Company/Schenck Process Transport N.A.
Private Sector Member	Nigel Mills	Hobart Corporation
Private Sector Member	Wayne Pugh	OCS Checkweighers, Inc.
Private Sector Member	Louis Straub	Fairbanks Scales, Inc.
Private Sector Member	Jerry Wang	A&D Engineering, Inc.
Private Sector Member	Walter Young	Emery Winslow Scale Company

Western Weights and Measures Association (WWMA) www.westernwma.org					
States	Alaska Arizona California	Colorado Hawaii Idaho	Montana Nevada New Mexico	Oregon Utah	Washington Wyoming
Contact	Brett Saum San Luis Obispo County Weights and Measures, California			(805) 781-5922 bsaum@co.slo.ca.us	
Annual Meeting	September 22 - 26, 2013			Kalispell, Montana	
Central Weights and Measures Association (CWMA) www.cwma.net					
States	Illinois Indiana Iowa	Kansas Michigan Minnesota	Missouri Nebraska	North Dakota Ohio	South Dakota Wisconsin
Contact	Sherry Turvey Kansas Department of Agriculture			(785) 862-2415 sherry.turvey@kda.ks.gov	
Annual Meeting	May 20 - 23, 2013			Overland Park, Kansas	
Interim Meeting	September 16 - 19, 2013			St. Charles, Missouri	
Southern Weights and Measures Association (SWMA) www.swma.org					
States	Alabama Arkansas Delaware District of Columbia	Florida Georgia Kentucky Louisiana Maryland	Mississippi North Carolina Oklahoma South Carolina	Tennessee Texas U.S. Virgin Islands	Virginia West Virginia
Contact	Stephen Benjamin North Carolina Department of Agriculture			(919) 733-3313 steve.benjamin@ncagr.gov	
Annual Meeting	October 7 - 9, 2013			Charleston, West Virginia	
Northeastern Weights and Measures Association (NWMA) www.newma.us					
States	Connecticut Maine	Massachusetts New Hampshire	New Jersey New York	Pennsylvania Puerto Rico	Rhode Island Vermont
Contact	James Cassidy City of Cambridge Weights and Measures Department, Massachusetts			(617) 349-6133 jcassidy@cambridgema.gov	
Annual Meeting	May 6 - 9, 2013			Saratoga Springs, New York	
Interim Meeting	October 16 - 17, 2013			Norwich, Connecticut	

President's Address

National Institute of Standards and Technology

Louisville, Kentucky

July 16, 2013

Dr. Willie E. May

Associate Director for Laboratory Programs/Principle Deputy

Dr. Willie E. May presented the following presentation on the behalf of the National Institute of Standards and Technology.



98th NCWM Annual Meeting
"On the Path to Tomorrow"
Louisville, Kentucky July 14-18, 2013

NIST Update

Dr. Willie E. May

Associate Director for Laboratory Programs and Deputy Director

National Institute of Standards and Technology

NIST
National Institute of Standards and Technology

National Institute of Standards and Technology (NIST)

- Non-regulatory agency within U.S. Department of Commerce

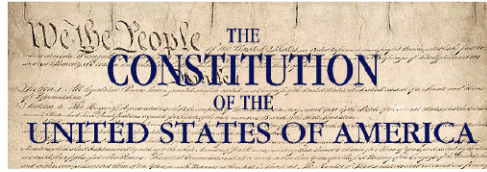

Article I, Section 8: The Congress shall have the power to ...*coin money, regulate the value thereof, and of foreign coin, and fix the standard of weights and measures*

- Founded in 1901 as National Bureau of Standards

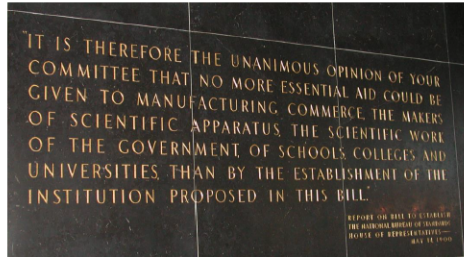

Unique Mission within the Federal Government ...
 to promote U.S. innovation and industrial competitiveness by advancing **measurement science, standards, and technology** in ways that enhance economic security and improve our quality of life

NIST-at-a-Glance

Major Assets

- ~ 3,000 Employees; 1800 Scientists and Engineers
- ~ 2,800 Associates and Facilities Users
- ~ 400 NIST Staff on ~1,000 national and international standards committees

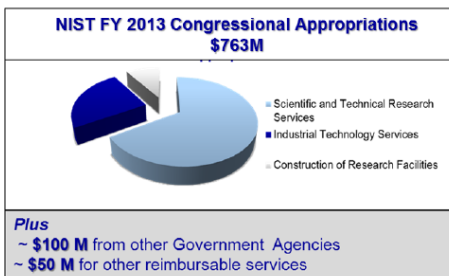

NIST has two main campuses.....



Gaithersburg, MD
 62 buildings; 578 acres



Boulder, CO
 26 buildings; 208 acres

- + two sites housing NIST radio stations:**
- Ft. Collins; 390 acres
 - Kauai; US Navy 30 acre site

and five joint institutes

- JILA – *applied physics*
- JQI – *quantum science*
- IBBR – *biotech*
- HML – *marine science*
- NCCOE – *cybersecurity*

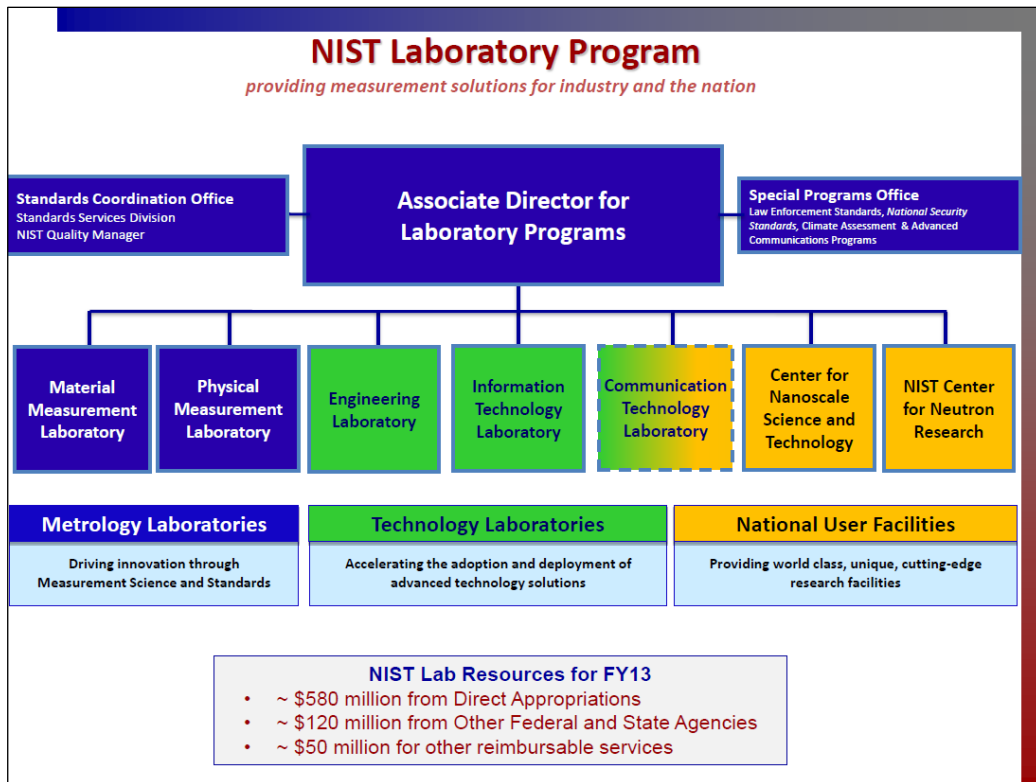

NIST: A Premier Scientific Institution

A world-leading measurement science and standards program

- Work resulting in 4 + 1 Nobel Prizes since 1997
- Kyoto Prize winner in 2011
- MacArthur Fellowship winner in 2003
- National Medal of Science winners in 1998 and 2007
- ~ 60 National Academy Members (10 current)
- ~ 120 National Society Fellows
- ~ 60 National/International Awards/yr



Bill Phillips
1997 Nobel Prize
in Physics



Eric Cornell
2001 Nobel Prize
in Physics



John Hall
2005 Nobel Prize
in Physics



David Wineland
2012 Nobel Prize
in Physics



John Cahn
2011 Kyoto Prize
in Materials Science

NIST (NBS) established in 1901

“It is therefore the unanimous opinion of your committee that no more essential aid could be given to

- manufacturing
- commerce
- the makers of scientific apparatus
- the scientific work of Government
- schools, colleges, and universities

than by the establishment of the institution proposed in this bill.”

Organic Act of 1901; Updated in 2008

Functions and activities of the Institute include:

- custody and dissemination of national standards
 - comparison of US national standards with those of other nations
- determination of physical constants and the properties of materials,
- solutions to measurement and standards problems of other government agencies
- providing (Innovation) assistance to industry
 - development of measurements, measurement methods and basic measurement technology
 - development of technology and procedures needed to improve quality, modernize manufacturing processes, ensure product reliability and cost-effectiveness, promote more rapid commercialization ...
 - operation of National User Facilities

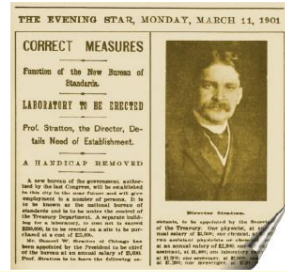

**House Committee on Coinage,
Weights and Measures ... on the
establishment of the National
Bureau of Standards (now NIST)
May 3, 1900**

Since our inception, in addition to maintaining the more traditional National physical standards, **we have also focused a significant portion of our research and measurement services activities on addressing contemporary societal needs.**

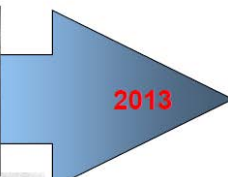

NIST Strategic Investment Priorities

- Advanced Manufacturing
- Advanced Materials
- the Environment and Consumer Safety
- Energy
- Bioscience and Health
- Information Technology & Cybersecurity
- Physical Infrastructure
- Forensics & Homeland Security

Topics Discussed Last Year at 2012 NCWM Conference

- Need for “Weights and Measures” throughout the Ages
- NIST: Our Mission, Scope of Activities, and New Organizational Structure
 - Activities in biology and healthcare
- NCWM and NIST: Partners in Measurement Service Delivery
- Measuring our Worth

Today’s Topics for Discussion

How NIST is carrying its dual responsibilities as the U.S. National Metrology Institute

- establishing and disseminating the U.S. National Standards for Measurement
 - critical to fair trade/commerce
 - an estimated 80% of global merchandise trade is influenced by testing and other measurement-related requirements of regulations and standards
- playing an increasingly critical role in supporting the U.S. Innovation Infrastructure

BOTH are critical to our economic security and quality of life.

NIST and NMI’s Around the World *are Working to link our global measurement system to the fundamental constants of nature*

Unit		Reference value used to define the unit		
		<i>in current SI</i>	<i>in the new SI</i>	
second,	s	$\Delta\nu(^{133}\text{Cs})_{\text{hfs}}$	$\Delta\nu(^{133}\text{Cs})_{\text{hfs}}$	Cs hyperfine splitting
metre,	m	c	c	speed of light in vacuum
kilogram,	kg	$m(\mathcal{K})$	h	Planck constant
ampere,	A	μ_0	e	elementary charge
kelvin,	K	T_{TPW}	k	Boltzmann constant
mole,	mol	$M(^{12}\text{C})$	N_{A}	Avogadro constant
candela,	cd	K_{cd}	K_{cd}	luminous efficacy of a 540 THz source

DNA as an Intrinsic Force Standard

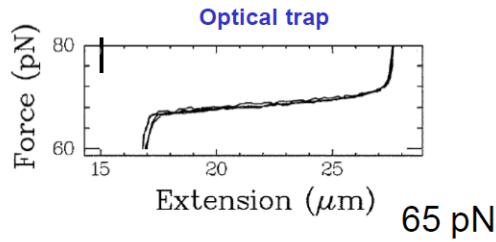
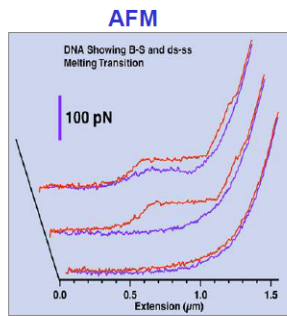

- DNA can be manufactured to atomic precision anywhere in the world.
- The force required to induce DNA transition is used as a biophysics “standard” – but firm metrological basis does not exist
- NIST is working to measure the DNA transition force with traceable metrology using approaches based on both optical and AFM techniques.



Redefinition of the kilogram



Currently:

“The kilogram is the unit of mass; it is equal to the mass of the international prototype of the kilogram.”

3rd CGPM, 1901

However:

New York Times
 (27 May 2003)

Scientists Struggling to Make the Kilogram Right Again

...The kilogram is getting lighter, scientists say, sowing potential confusion over a range of scientific endeavor...

Scatter in IPK copies

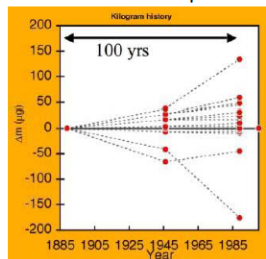

Current e-Kg scatter

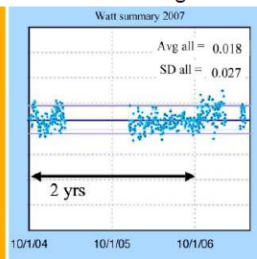

Same vertical scale!

Electronic kilogram project

Mass is the only SI unit still defined by a physical artifact

- NIST and other NMIs are working to redefine this unit in terms of natural phenomena
- The “Watt Balance”—compares precise measure of voltage and resistance with force and velocity
- Int. Gen. Com Weights and Measures has recommended this redefinition



© Robert Rathke

Demonstration of Underlying Principles for Operation of the “Watt Balance” during 2013 UK Royal Society Summer Science Exhibit

To view the embedded material, click this link:
http://www.youtube.com/watch?feature=player_embedded&v=oQsbxT8DQ4U

https://www.youtube.com/watch?feature=player_embedded&v=oQsbxT8DQ4U



Si-sphere for the re-determination of N_A
PTB



$$N = V_{\text{Sphere}} / V_{\text{Atom}}$$

$$n = N / N_A = m / M$$

$$N_A = (M / m) (V_{\text{Sphere}} / V_{\text{atom}})$$

$$M = x(^{28}\text{Si}) \cdot M(^{28}\text{Si}) + x(^{29}\text{Si}) \cdot M(^{29}\text{Si}) + x(^{30}\text{Si}) \cdot M(^{30}\text{Si})$$

Challenge: Target uncertainty of $U_{M,\text{rel}} \leq 1 \cdot 10^{-8}$

CCQM Paris 20.04.-23.04. 2009
(2)

N_A connects to the Planck Constant

$$h = \frac{c \alpha^2 A_r(e) M_u}{2 R_\infty N_A}$$

Constant	Symbol	2006 CODATA value	Relative standard uncertainty
Electron relative atomic mass	$A_r(e)$	$5.485\,799\,0943(23) \times 10^{-4}$	4.2×10^{-10}
Molar mass constant	M_u	0.001 kg/mol	defined
Rydberg constant	R_∞	$10\,973\,731.568\,527(73) \text{ m}^{-1}$	6.6×10^{-12}
Planck constant	h	$6.626\,068\,96(33) \times 10^{-34} \text{ Js}$	5.0×10^{-8}
Speed of light	c	299 792 458 m/s	defined
Fine structure constant	α	$7.297\,352\,5376(50) \times 10^{-3}$	6.8×10^{-10}
Avogadro constant	N_A	$6.022\,141\,79(30) \times 10^{23} \text{ mol}^{-1}$	5.0×10^{-8}

This provides an independent connection to approaches to the kilogram based on the Planck constant, but requires a total relative uncertainty of $\leq 10^{-8}$ total relative uncertainty

Recent Planck Value Measurements Worldwide

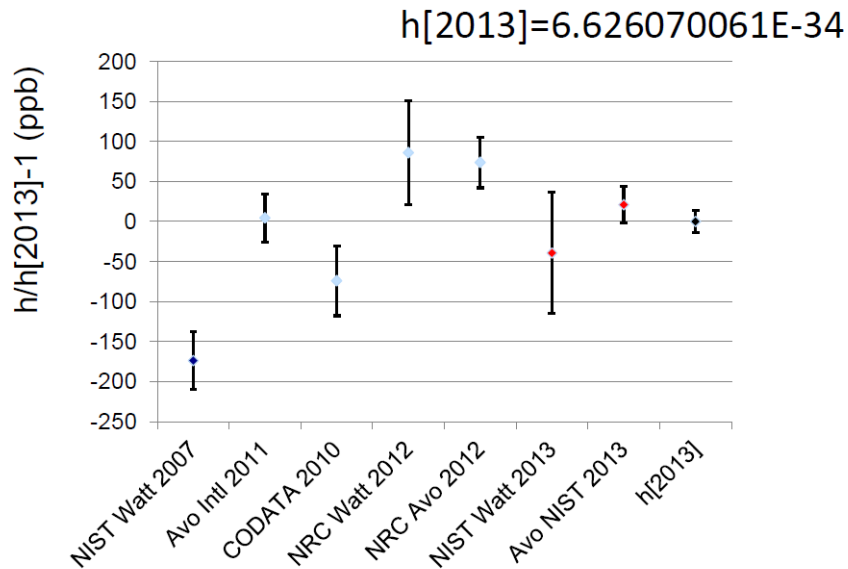

Benefits of the Redefinition of the SI

- The new “Quantum” SI will be fixed by well recognized fundamental constants and properties of atoms
 - This will have achieved the original goals of the Treaty of the Meter – **a set of units based on invariants of nature**
- Will be consistent with all existing legal metrology including OIML R111
- Will allow instrumentation to improve relative accuracy of mass measurements at masses other than 1 kg

Recent progress indicates that we are on a path to a potential redefinition in the next 4-5 years

Dissemination of New SI Kilogram

- Establish traceability to and dissemination of new kg definition
- Unique approach to develop dissemination system that directly ties current air-based kg definition to vacuum-based future definition using magnetic levitation
- Develop stable mass standards and methods for controlling surface and environmental factors

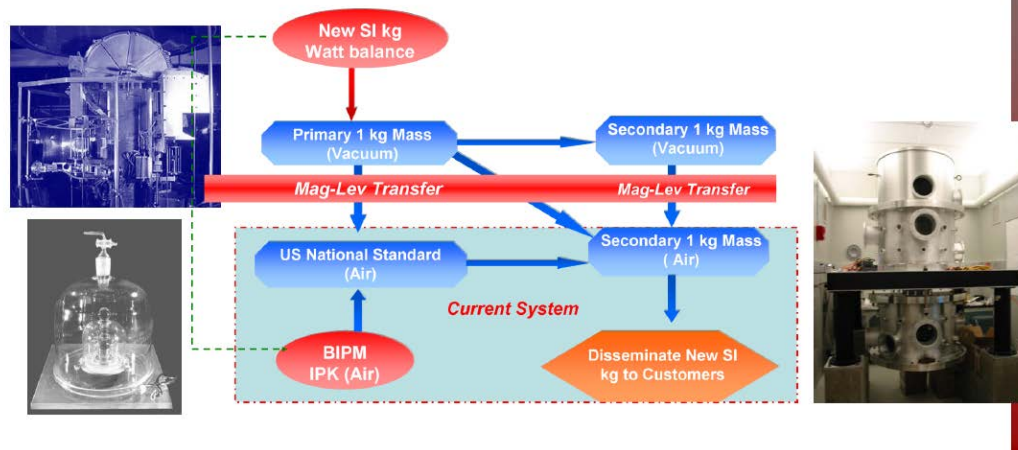

NIST Labs should support NIST’s Mission through ...

NIST Basic and Applied Research underpins Scientifically-Sound, Metrologically-Based Competencies and Measurement Capabilities

that are

Internationally Vetted and Recognized

to provide

- **NIST Measurement Services**
 - Standard Reference Materials
 - Standard Reference Data
 - Calibrations
 - ...
- Validated Reference/Test Methods and Measurement Guides
- Measurement Services for other government agencies
- Value-assignment of high priority customer-provided samples or materials
- *Peer Reviewed Publications for measurement technology transfer*
- *Documentary Standards*

base-funded

reimbursable

CIPM Mutual Recognition Arrangement

... was established in 1999 in response to a growing need for an open, transparent and comprehensive scheme to give users **reliable quantitative information on the comparability of national metrology services** and to provide the technical basis for wider agreements negotiated for **international trade, commerce and regulatory affairs**.

Requires:

1. Declaring and documenting calibration and measurement capabilities (CMCs)
2. Evidence of *successful* participation in formal, *relevant* international comparisons
3. Demonstration of system for assuring quality of each NMI's measurement services

CIPM Mutual Recognition Arrangement

... was established in 1999 in response to a growing need for an open, transparent and comprehensive scheme to give users **reliable quantitative information on the comparability of national metrology services** and to provide the technical basis for wider agreements negotiated for **international trade, commerce and regulatory affairs**.

- Originally signed in by directors of NMIs of 38 member states of the Metre Convention
- It formalized existing *ad hoc* relationships, especially in the international chemical measurements community
- The MRA has now been signed by the representatives of over 85 institutes

NIST Role in CIPM MRA

Began as an “unfunded mandate” with intense involvement in:

- Documentation of our capabilities for measurement service delivery
 - NIST has ~**2,300** of the ~26,000 Calibration and Measurement Capabilities (CMCs) published in the CIPM MRA Appendix C .
- Key Comparisons
 - NIST has participated in ~**370** Key Comparisons since the inception and has been the coordinating laboratory for over 80 of these
- Establishing Internationally-recognized Quality Systems for our Measurement Services

CIPM MRA, once looked upon as an “unfunded mandate”, has enabled us to identify “spikes” in the increasingly “flat world” and establish strategic collaborations for both research and standards development purposes.

➡ **Better services for our customers**

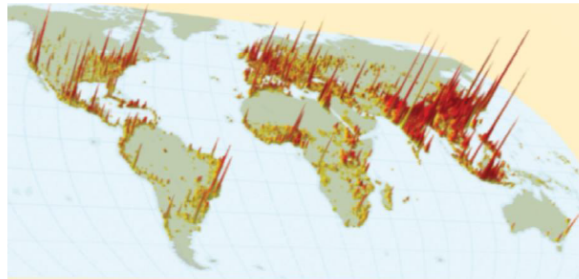

Graphic Source: “The World is Spiky” by Richard Florida, published in The Atlantic Monthly, October 2005

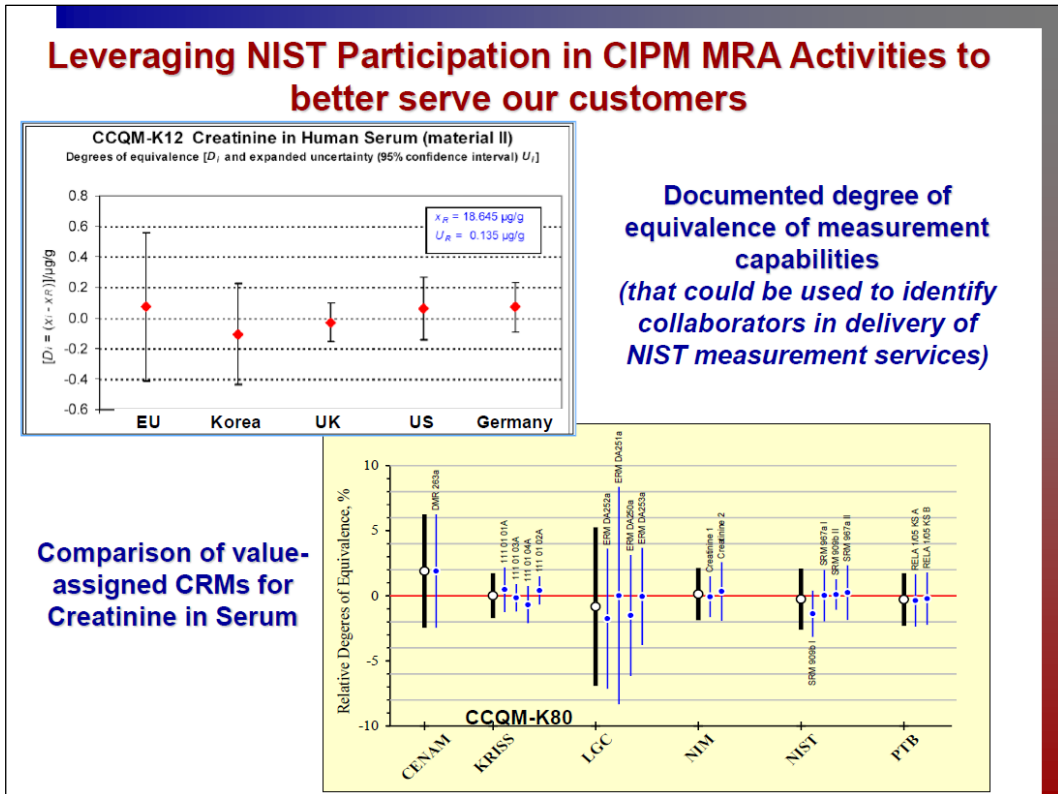

U.S. Innovation Agenda – NIST has an increasing role

Advanced Manufacturing

- NIST Labs
 - Precision Measurements
 - Bio and Nanomanufacturing
 - Smart Manufacturing
 - Advanced Materials
- National Advanced Manufacturing Program Office
 - AMTech
 - NNMI
- Manufacturing Extension Partnership
 - MTAC

Cybersecurity

- Executive Order – Framework for Critical Infrastructure
- National Cybersecurity Center of Excellence

Advanced Communications

Forensic Science

Healthcare

We (NIST) want to make sure that our programs are focused on **what we “Should Do” rather than what we “Could Do”** to strengthen U.S. Manufacturing, new Materials Discovery and Innovation."

U.S. Innovation Agenda – NIST has an increasing role

Both the **American Competitiveness Initiative** & the **America COMPETES Act** called for substantially increased funding for NIST laboratory Programs

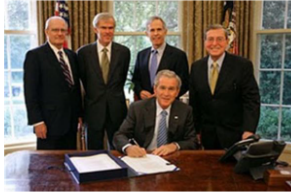

Base Growth by Focus Area (2006 - 2013)

	\$ Millions
• Advanced Communications	+ 5.0
• Advanced Manufacturing and Materials	+ 51.0
• Bioscience and Health	+ 14.7
• Cybersecurity and IT	+ 44.0
• Energy	+ 21.2
• Greenhouse Gas Measurements	+ 15.2
• Measurement Science/Service	+ 9.0
• Nanotechnology	+ 17.8
• NCNR capacity increase	+ 16.3
• National Physical Infrastructure and Construction	+ 14.4
• Quantum Science	+ 10.8
• Restoration of Core Programs	+ 20.0
• STEM Activities	+ 3.0

Healthcare: Lack of Standards has Economic and Quality-of-Life Implications

U.S. Spends ~ \$2.5 trillion on Health Care Annually of which 10-15% is associated with measurements

- ~ 70% of health care decisions are based on results from clinical laboratory measurements
 - *Yet, standards exist for only 10% of the 700 routinely performed clinical laboratory tests*
- **60 million CT tests performed annually to measure changes in lesions are limited by ability to discern only large changes in size/metabolism**
 - *This is a direct consequence to lack of standards to monitor equipment performance*
- **Costs of repeat measurements amounts to 1.5 B US\$ per year in Germany according to the German Health Report of 1998 (www.gbe-bund.de)**

Measurement Bias also Affects Quality of Life and leads to

- **Incorrect diagnosis and treatment**
- **Impairment of patient well-being**

NIST has maintained Standards for 13+ Health Status Markers for 25+ years

Reference Systems are Currently in Place for Many Well-Defined Markers that are:

- Relatively small well-defined molecular or elemental species
- Typically, can be determined using isotope-dilution GC or ICP ID/MS-based methodologies

<u>Marker</u>	<u>Disease State</u>
Calcium	Cancer, Blood Clotting
Chloride	Kidney Function
Cholesterol	Heart Disease
Creatinine	Kidney Function
Glucose	Diabetes
Lithium	Antipsychotic Treatment
Magnesium	Heart Disease
Potassium	Electrolyte Balance
Sodium	Electrolyte Balance
Triglycerides	Heart Disease
Urea	Kidney Function
Uric Acid	Gout
Vitamins	Nutrition Status

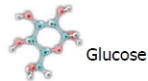

Isotope Dilution/Mass Spectrometry-based Definitive Methods

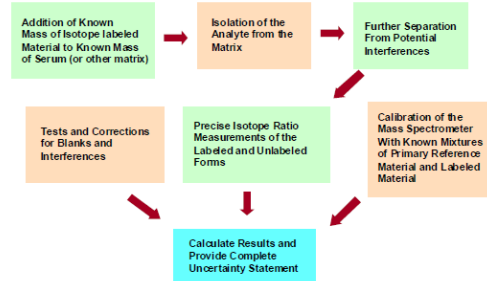

Laboratory Medicine: NIST Program Expansion Plans

Reference systems for markers that typically exhibit:

- High molecular mass (>20,000 daltons)
- Heterogeneity, low concentration, instability of analyte form
- Cannot all be determined using GC- ID/MS or ICP/MS-based methodologies
- Such as the following:

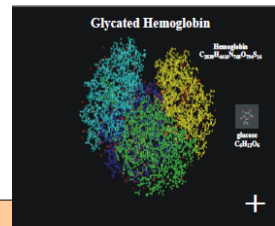

Protein Analysis

- Single Blood Protein Biomarkers
 - **Troponin-I** *Myocardial Infarction*
 - C-Reactive Protein *Risk of Heart Attack*
 - **PSA** *Prostate Cancer*
 - Albumin *Kidney Function*

Genetic Testing

- Single Gene Mutations
 - Genetics Directed Therapy
 - **Her2-Nu** *Breast cancer*
 - CYP2C9 and VKORC1 *Warfarin Dosage*
 - Kras *Colon Cancer*
 - Diagnostics
 - DNA Triplet Repeat *Fragile X*
 - CAG Repeats *Huntington's Disease*
- Genome Sequencing to support Direct to Consumer Genetic Testing

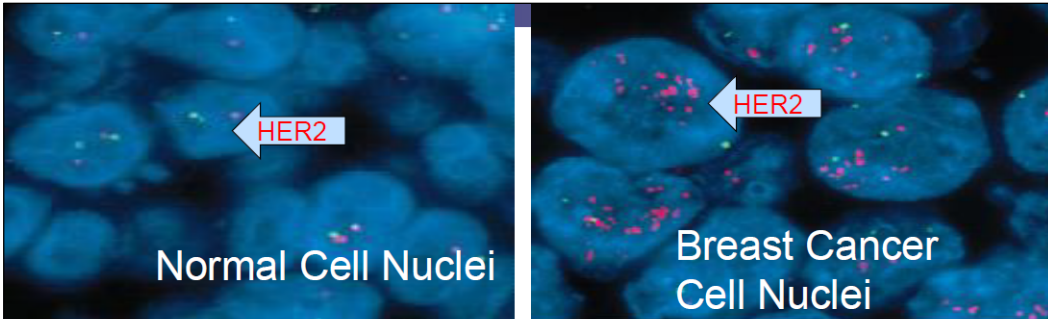

Normal Cell Nuclei

Breast Cancer Cell Nuclei

“The College of American Pathologists and the American Society of Clinical Oncology, which issued guidelines for the HER-2 estimated that around 40% of HER-2 testing may be inaccurate” (20% false positive; 20% false negative)

HER-2 Tests
180,000/year

- False positive** → **Get Herceptin unnecessarily**
Up to 36,000
 - Expensive
 - Numerous side effects
- False negative** → **Herceptin Treatment withheld**
Up to 36,000
 - Inappropriate treatment
 - Increased morbidity
 - Increased mortality

<http://online.wsj.com/article/SB119941325367266813.html>

Helping Ensure the “Science” in Forensic Science

A landmark forensics report by U.S. National Research Council of the National Academies was issued in Feb. 2009.

“With the exception of nuclear DNA analysis, no forensic method has been rigorously shown to have the capacity to consistently, and with a high degree of certainty, demonstrate a connection between evidence and a specific individual or source.”

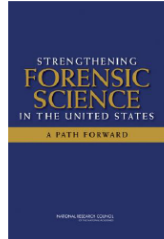

New Role for NIST:

- **National Commission on Forensic Science**
 - Was established via MoU on Feb. 8, 2013 between DOJ and NIST
 - to help improve the reliability of forensic science data/information and to develop policy recommendations for the U.S. Attorney General.
 - to be comprised of forensic science practitioners, academic researchers, prosecutors, defense attorneys, judges, and other relevant stakeholders
- **NIST will:**
 - Co-Chair the Commission
 - Administer Guidance Groups of subject-matter experts for specific forensic science disciplines
 - Validate select existing forensic science methods and guidance
 - Develop and critically evaluate new methods

Forensics at NIST

NIST has a long and rich history of work in support of law enforcement.

Currently providing research and measurement services such as validated test methods, Standard Reference Materials, and Reference Data in areas such as:

- crime scene investigations
- computer forensics
- fire investigations
- drug detection
- drunk driving testing
- biometrics (fingerprints and handwriting analysis)
- firearms/ballistics
- standards for body armor, nonlethal weapons
- explosives detection technologies
- sports integrity/fairness
- genetics and DNA-based identification



that support the Departments of Defense, Justice, and Homeland Security in carrying out their programs.

Why the focus on advanced communications?

- Technology advances in communications have revolutionized how we work, entertain, govern, and defend ourselves.
- Multiple near and long-term challenges must be addressed
 - Spectrum scarcity;
 - Broadband access driving needs for ever-higher bandwidth;
 - The vulnerability of all Internet-capable devices to a variety of security threats; and
 - The threat of natural disasters and terrorism on communications infrastructure.

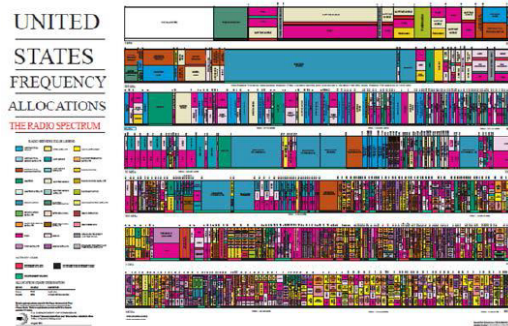

Response – The Center for Advanced Communication

NIST and NTIA will work together to establish the Center for Advanced Communications

- MOU between NIST and NTIA to establish the Center signed on May 24th, 2013

Planned Center Objectives:

- Enhancing mission effectiveness of both agencies by better coordinating research and testing functions of NIST and NTIA
- Promoting interdisciplinary research, development, and testing in advanced communication-related areas (radiofrequency technology, digital information processing, cybersecurity, etc.)
- Providing a single focal point for engaging both industry and other government agencies



Program Update: Improving Critical Infrastructure Cybersecurity a.k.a. Cybersecurity Executive Order (EO)

“...America must also face the rapidly growing threat from cyber attacks. I signed a new executive order that will strengthen our cyber defenses by increasing information sharing, and developing standards to protect our national security, our jobs, and our privacy...”

- President Obama in the 2013 State of the Union Address

- Leverages two key NIST roles – as a convener and as a technical agency
- NIST to develop standards framework to reduce cyber risks to critical infrastructure (the "Cybersecurity Framework").
- Partnership with industry, standards organizations and government agencies
- Short time frame – draft framework in 8 months, first framework in 1 year.



Credit: K. Taino/NIST & Shutterstock



Author: Pikkao
Creative Commons License

Program Update: Improving Critical Infrastructure Cybersecurity a.k.a. Cybersecurity Executive Order (EO)

“...America must also face the rapidly growing threat from cyber attacks. I signed a new executive order that will strengthen our cyber defenses by increasing information sharing, and developing standards to protect our national security, our jobs, and our privacy...”

- President Obama in the 2013 State of the Union Address

- Leverages two key NIST roles – as a convener and as a technical agency
- NIST to develop standards framework to reduce cyber risks to critical infrastructure (the "Cybersecurity Framework").
- Partnership with industry, standards organizations and government agencies
- Short time frame – draft framework in 8 months, first framework in 1 year.



Credit: K Talbot/NIST & Shutterstock



Author: Pkkiao
Creative Commons License

Program Update: National Cybersecurity Center of Excellence (NCCoE)

- National Cybersecurity Excellence Partners (NCEP)

- | | |
|----------------------|------------------------------------|
| - Cisco Systems Inc, | - RSA |
| - Hewlett-Packard, | - Splunk |
| - HyTrust | - Symantec |
| - Intel | - Vanguard Integrity Professionals |
| - McAfee | - Venafi |
| - Microsoft | |

- In process of setting up FFRDC as governance structure.



Lack of recognition is a good thing!

The weights and measures system in the U.S. works so well that its accuracy is taken for granted.



It’s not always pleasant, but it’s fair -- Thanks to your efforts.

... and We’re Here to Help !!!

We are continuing the ramp up of our training efforts

- IACET Accredited Training Program
- 20 new regional instructors trained at NIST last April
- Developing new hands-on and online courses
- 9 classes being offered around the country between now and November



Challenges to Weights and Measures Officials and the NCWM

- Doing more with less
- New Technologies (GPS for Taxis, weighing in motion scales)
- New Fuels (hydrogen, electricity, LNG, CNG)

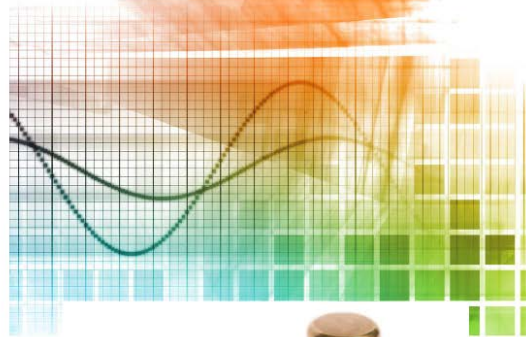

© Aasaf Eliason/shutterstock.com

But through it all, we're here to help !!!!



Thanks for Your Attention

Willie E. May
*Associate Director for Laboratory Programs & Deputy Director
National Institute of Standards and Technology
100 Bureau Drive
Gaithersburg, Maryland 20899-1000*

*(301) 975-2300
wem@nist.gov*



Questions and Comments?



THIS PAGE INTENTIONALLY LEFT BLANK

Chairman’s Address

National Conference on Weights and Measures

Louisville, Kentucky

July 16, 2013

Stephan Benjamin

North Carolina Department of Agriculture and Consumer Services

Thank you Commissioner Comer and Dr. May for being with us today:

Good morning and welcome to the 98th Annual Meeting of the National Conference on Weights and Measures (NCWM). It has been my honor and privilege to serve as Chairman this past year. I’ll admit it has been a challenge at times, but it has been a rewarding experience.

My theme this year was “On the Path to Tomorrow.” With that in mind, I would like to briefly review some of the accomplishments of NCWM this past year. We just launched our new website, which has a number of new features and is friendly to mobile devices. The Professional Certification Program launched two new tests, Small Capacity Weighing Systems Class III and Package Checking Basic and they are working on two more. We have advertised for a new staff position that will allow for the expansion of the VCAP program and provide another option for NTEP evaluations.

I have mentioned some of these items as I attended the regional meetings this year. While there, I often heard a comment or two about membership. How the number of members has declined the last few years along with the budgets of the weights and measures programs as well as our industry members. The Board of Directors has worked for a number of years to make improvements in our services and benefits, in part, to make membership attractive; to make it of value to a member. While membership numbers are great, what keeps us successful is *participation*.

This is most obvious with the Standing Committees and the Board of Directors, as we sit before you through open hearing and voting sessions. Then we have our Subcommittees, the NTEP Sectors, Work Groups and Task Groups. You will find a list of these willing participants in the front of each Publication 15 and 16. In the last newsletter, there was a list of Subject Matter Experts or SMEs that have contributed to the Professional Certification Program. I would even extend this list of participants to the Regional Associations as they mirror the NCWM structure.

My point is that participation is critical to this organization. There are many places for you or members of your staff to contribute, even if one cannot attend the Interim or Annual meetings. The SMEs and NTEP Sectors are excellent examples of this and include a good mix of regulators and industry. NCWM and National Institute of Standards and Technology (NIST), Office of Weights and Measures (OWM) have the ability to host conference calls and web-meetings. These have been used by Work Groups and Task Groups which has allowed for a lot of work to be done between meetings and involve new people who otherwise could not attend.

So, I would like to thank all of you that have stepped up and participated in one or more of the many committees, subcommittees or other groups within NCWM and the Regional Associations, and I hope you continue to do so. I would encourage all of you to seriously consider accepting one of these roles if you are asked; or volunteering for one if you have an interest or expertise. It is also an opportunity to both learn and teach.

The newly formed Training Manual task group, for example, is in need of members. Their efforts are complimentary to the Professional Certification Program, so it would benefit many outside this room when they are successful with their task.

General – 2013 Final Report
Chairman’s Address

Don’t be shy! I was the manager of our fuel quality program when I became the Director of the Standards Division in August 2004. I knew very little about the Conference then. I had attended one Interim Meeting in January 2005 before I was asked to serve on the Laws and Regulations Committee. I will admit I hesitated to accept the appointment. However, I decided what better way for me to learn this new world of weights and measures and start making contacts with my peers and industry. Participation is part of where the NCWM’s strength lies.

In closing, what we do here at NCWM, both at this meeting and outside of it, in our committees and work groups, is a team effort. I would like to thank the membership and the Board of Directors for their support this past year. The NCWM staff went through a lot of changes, but they were always professional and accomplished their goals. Thank you to our Associate Members and Measurement Canada as they actively participate in our processes. Finally, I would like to recognize our partners in the NIST Office of Weights and Measures, for without their technical expertise and daily work in the areas of Weights and Measures and Legal Metrology we would be hard pressed to move forward on many of the issues that come before us.

Thank you all for allowing me to be your chairman this past year and I look forward to working with John this coming year.

Chairman Elect’s Address
National Conference on Weights and Measures
Louisville, Kentucky
July 16, 2013
John Gaccione
Westchester County, New York

Good morning and thank you.

I begin by thanking Steve Benjamin. Steve made being Chairman look easy. But the reality is that Steve never stopped working for the National Conference on Weights and Measures (NCWM). NCWM continues to be a well-respected organization because of Steve. Thank you, Steve, for all of your guidance in preparing me in my new role as NCWM Chair.

I would also like to thank all the members of the Conference for electing me Chairman of NCWM. I am humbled, and it is an honor I do not take lightly.

More thanks go to Kurt Floren and Tim Tyson for their advice and help. And to all the previous chairpersons for their hard work and dedication in bringing the Conference to where it is today, an organization that is respected, recognized, and a model for other organizations on how to get things done.

Thank you NCWM staff: Don, LuAnne, Elisa, and Jim. Everyone should take a moment to see how much they do and how well they do it. And thanks also go to Carol Hockert and the National Institute of Standards and Technology (NIST) staff for their never ending assistance.

With that, I promise I will be brief, “not boxers,” briefs.

Going slightly off course, I wanted to share with everyone a column that some of you may have seen, but what it says is important.

It appeared in the “About.com Guide” (<http://moneyover55.about.com/b/2012/08/13/weights-measures-and-the-election.htm>), August 13, 2012.

Weights, Measures, and the Election

by Dana Anspach, she writes:

As I'm driving to work today the radio morning show began talking about my state's Weights and Measures Department. Apparently they go around testing gas pumps to see if in fact we are getting what we pay for at the pump. I had no idea such a department existed. The conclusion? Of the pumps tested about 200 some pumps were overcharging... but 800 were giving us more than we paid for.

Until I heard this, it never even crossed my mind to wonder if I was being ripped off at the gas pump. How the heck would I know if in fact 16.3 gallons was delivered? I simply trusted the system.

It wasn't until this morning's drive that it hit me that the reason I can trust the system is because some of my tax payer dollars pay for the Weight and Measures department. I wonder how many

other things my tax payer dollars pay for that I am simply unaware of, and would in fact, be in favor of?

Words well written and worth repeating. Spread the word.

Today we face challenges that were never dreamed about 10 or 15 years ago.

Right now you can:

- Catch up on television news, order lunch and earn points towards future purchases while filling up at the gas pump.
- Fuel up with an “alternative” to good old gasoline and diesel.
- Stand in an aisle in a store and compare prices with other nearby stores and on the Internet, and read consumer reviews about a product.
- Go into a grocery store, scan and bag your own purchases long before you reach the cashier. Or from home, place an order with the supermarket or grocery store and have it delivered to your door step.
- Track a purchase on its long journey from its supplier to your home.
- Charge your electric vehicle while at your workplace or at transportation hub or while shopping.
- Look at the label on an item and know not just its weight and who packaged it, but its nutritional value, its country of origin and under what conditions it was grown, prepared, and packaged.
- Encounter a new method of sale for how a commodity is sold.

Every day, we see how rapidly change occurs.

NCWM must be ready to meet these new challenges.

While we continue to ensure a fair and equitable marketplace, we must recognize that change and new technology arrive at a much faster pace than it did in the past.

With that my theme for the coming year is “*Meeting Tomorrow's Challenges Today.*”

I constantly remind my own staff that “change is good”. Change is not easy.

Change many times leads to a new, more efficient way of getting things done. Change allows the formulation of new ideas. Change allows us to meet tomorrow's challenges.

Paraphrasing President John Kennedy, “We chose to do things, not because they are easy, but because they are hard, because the results will measure the best of our energies and skills.”

Are we ready for those new challenges? I believe we are; with everyone's participation, NCWM is ready to meet new challenges.

Thank you all, please arrive home safely, and see you in Albuquerque.

And now, my appointments:

Specifications and Tolerances Committee: Matt Curran, Florida

Laws and Regulations Committee: Craig Vanburen, Michigan

Steve Grabski, Walmart

Professional Development Committee: Julie Quinn, Minnesota

Richard Shipman, Rice Lake Weighing Systems

Nominating Committee: Stephen Benjamin, Chair, North Carolina

Charles Carroll, Massachusetts

Tim Tyson, Kansas

Tim Chesser, Arkansas

Joe Gomez, New Mexico

Frank Greene, Connecticut

Angela Godwin, Ventura County, California

Chaplain: Steve Langford, Cardinal Scales

Parliamentarian: Lou Straub, Fairbanks Scales

THIS PAGE INTENTIONALLY LEFT BLANK

2013 National Conference on Weights and Measures Special Award Recipients

Contribution Award:

Maureen Henzler, Kansas Department of Agriculture

Distinguished Service Awards:

Mike Belue, Retired, Belue Associates

Wes Diggs, Retired, Virginia

Ken Simila, Retired, Oregon

Lou Straub, Fairbanks Scales

Juana Williams, NIST Office of Weights and Measures

Lifetime Achievement Award:

Dr. Charles (Charley) H. Greene, Retired, New Mexico

Attendance Recognition:

5 Years

- | | |
|----------------------|---|
| • David Calix | NCR Corporation |
| • Ryanne Hartman | Michigan Department of Agriculture |
| • William Hornbach | Chevron Products Company |
| • Henry Kellogg | Compucom |
| • Michael Kerr | Southern Company Services |
| • Russ Lewis | Marathon Petroleum Company LP |
| • Tim Lloyd | Montana Weights and Measures Bureau |
| • Girard Lukowiak | City of East Orange, New Jersey |
| • James McGetrick | BP Products |
| • Paul Moyer | Nebraska Division of Weights and Measures |
| • Rebecca Richardson | MARC IV Consulting |
| • Mike Roach | VeriFone |

10 Years

- | | |
|------------------------|--|
| • Joe Benavides | Texas Department of Agriculture |
| • Paul Glowacki | Murray Equipment, Inc. |
| • Raymond Johnson, Jr. | New Mexico Department of Agriculture |
| • Brett Saum | San Luis Obispo County Weights and Measures,
California |
| • Jack Walsh | Town of Wellesley, Massachusetts |

15 Years

- | | |
|-------------------|---|
| • Stacy Carlsen | Marin County Weights and Measures, California |
| • Ed Luthy | Schenck Process |
| • Curtis Williams | CP Williams Energy Consulting, LLC |

General – 2013 Final Report
Awards

20 Years

- Marilyn Herman
- Neal Nover

Herman and Associates
WinWam Software

25 Years

- Richard Tucker

RL Tucker Consulting, LLC

35 Years

Ross Andersen

no affiliation

Report of the Board of Directors (BOD)

Mr. Stephen Benjamin, Chairman
North Carolina

100 INTRODUCTION

This is the report of the Board of Directors (hereinafter referred to as the “Board”) for the 98th Annual Meeting of the National Conference on Weights and Measures (NCWM). This report is based on the Interim Report offered in the NCWM Publication 16, testimony heard at public hearings, comments received from the regional weights and measures associations and other parties, the addendum sheets issued at the Annual Meeting, and actions taken by the membership at the voting session of the Annual Meeting. The Informational items presented below were adopted as presented when the Committee’s report was approved.

Table A identifies the agenda and appendix items. Agenda items are identified in the Report by Reference Key Number, Item Title, and Page Number. Item numbers are those assigned in the Interim Meeting agenda. A Voting item is indicated with a “**V**” after the item number. An item marked with an “**T**” after the reference key number is an Informational item. An item marked with a “**D**” after the reference key number is a Developing item. The developing designation indicates an item has merit; however, the item was returned to the submitter for further development before any action can be taken at the national level. An agenda “Item Under Consideration” is a statement of proposal and not necessarily a recommendation of the BOD. Suggested revisions are shown in **bold** face print by ~~striking out~~ information to be deleted and underlining information to be added. Table B lists the results of any Voting Items.

Note: It is the policy to use metric units of measurement in publications; however, recommendations received by NCWM technical committees and regional weights and measures associations have been printed in this publication as submitted. Therefore, the report may contain references to inch-pound units.

Subject Series List

Introduction	100 Series
Activity Reports.....	110 Series
Strategic Planning, Policies, and Bylaws.....	120 Series
Financials.....	130 Series
Other Items – Developing Items.....	140 Series

**Table A
Table of Contents**

Reference Key	Title of Item	BOD Page
100	INTRODUCTION	1
110	ACTIVITY REPORTS.....	3
110-1	I Membership and Meeting Attendance	3
110-2	I NCWM Newsletter and Website.....	5
110-3	I Meetings Update	6
110-4	I Participation in International Standard Setting	7
110-5	I Associate Membership Committee (AMC) Activity	8
120	STRATEGIC PLANNING, POLICIES, AND BYLAWS.....	9
120-1	I Strategic Planning	9
120-2	I Regional Support	10
120-3	I Standing Committees Support	11
120-4	V Section L. Classifications for Agenda Items, Section M. Developing Items	13
130	FINANCIALS	15
130-1	I Financial Report.....	15

APPENDICES

- A — Item 110-4: Report of the Activities of the International Organization of Legal Metrology (OIML) and Regional Legal Metrology Organizations A1
- B — Item 110-5: Associate Membership Committee (AMC) Agenda and Draft Meeting Minutes..... B1

**Table B
Voting Results**

Reference Key Number	House of State Representatives		House of Delegates		Results
	Yeas	Nays	Yeas	Nays	
120-4	Unanimous Voice Vote of all Membership				Adopted

Table C
Glossary of Acronyms and Terms

Acronym	Term	Acronym	Term
AMC	Associate Membership Committee	NIST	National Institute of Standards and Technology
CTT	Conformity to Type	NTEP	National Type Evaluation Program
ISWM	International Society of Weighing and Measuring	OIML	International Organization of Legal Metrology
MAA	Mutual Acceptance Arrangement	OWM	Office of Weights and Measures
L&R	Laws and Regulations Committee	PDC	Professional Development Committee
NCWM	National Conference on Weights and Measures	VCAP	Verified Conformity Assessment Program

Details of All Items
(In order by Reference Key)

110 ACTIVITY REPORTS

110-1 I Membership and Meeting Attendance

Membership levels remain fairly steady, not yet rebounding to levels experienced before the decline in the economy and organizational budgets.

NEWMA members support continued outreach to other organizations such as the presentation Mr. Jim Truex provided to International Society of Weighing and Measuring (ISWM) this year. Associate Membership Committee (AMC) members are in a position to draw in more members from other industries, too. A member commented that the NCWM Board should be more aggressive to get new members. There was concern for maintaining a quorum at the Annual Meeting during continued economic stress. Special deals or professional recruitment may make sense to get more members to attend Annual and Interim Meetings. NEWMA supports the development of a toolkit to help jurisdictions garner legislative support and avoid privatization of weights and measures programs (see Item 110-5). The Professional Certification Program should get more people involved and that may increase membership.

The Board recognized that the pool of potential members, especially regulatory officials, has significantly decreased as a result of downsized or eliminated programs resulting from budget cuts. The Board does believe that membership levels will significantly increase once the Professional Certification Program is fully developed and can be referenced for registered service agencies and inspector pay grades. The price structure for the exams is set to heavily favor membership as an alternative to paying non-member exam fees.

The following is a comparison of NCWM membership levels for the past ten years.

Membership Levels for the Past 10 Years

Member Type:		6/12	6/11	6/10	6/09	6/08	6/07	6/06	6/05	6/04
Associate	818	842	813	814	822	848	863	837	828	837
Foreign Associate	50	58	62	53	53	56	53	61	41	42
Total Associate										
NIST	16	16	16	12	14	15	14	12	9	18
Other Federal	10	11	11	12	10	9	9	13	12	18
State	558	589	567	565	696	831	825	812	847	828
Local	486	487	495	524	558	554	565	492	490	527
Foreign Government	13	14	14	12	24	22	31	23	31	21
Total Government										
Retired	198	195	202	196	196	232	221	215	225	225
Grand Total	2149	2212	2180	2188	2,373	2,567	2,581	2,465	2,483	2,516

Annual Membership Totals

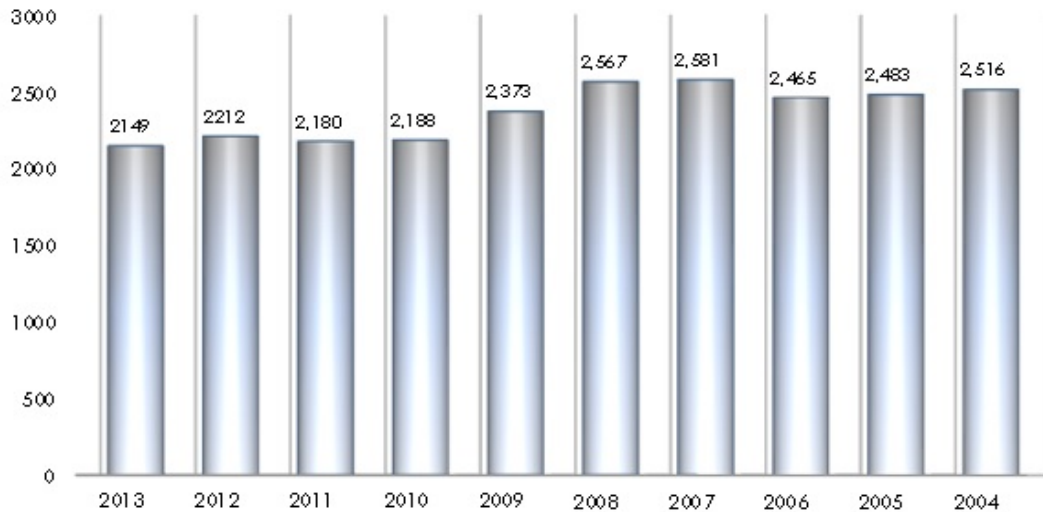

The attendance for the 2012 and 2013 Interim Meetings in New Orleans, Louisiana, and Charleston, South Carolina, respectively was very strong. Attendance also improved for the 97th Annual Meeting, in Portland, Maine, and those levels were maintained very closely for the 98th Annual Meeting in Louisville, Kentucky. Participation has been

very good for the Sunday afternoon special work sessions of Subcommittees and Task Groups. These sessions benefit the standards development process, and add value for stakeholders who attend Interim and Annual Meetings. See Item 110-3 for information on future meetings.

110-2 I NCWM Newsletter and Website

Newsletter:

The Board continuously considers ways to monitor and improve the content of the newsletter and website. Members are encouraged to bring ideas and articles forward for inclusion in newsletters. Of particular interest are articles that would be pertinent to field inspectors and the service industry.

Website Improvements:

At the 2012 Annual Meeting, the Board of Directors approved a number of enhancements to the website. Some of these new features include:

- Add a mobile-friendly version for popular features including the NTEP database search;
- Add the option of instant PDF download for NCWM Publication 14 sales;
- Add the ability to apply online for NTEP certification;
- Improve the shopping cart experience; and
- Full website integration with the Professional Certification Program testing site for an automated customer experience.

The new website was functional in May 2013.

NEWMA voted to invest \$1,500 to add online meeting registration and dues payments to their website as part of the project scope for NCWM's new website. That project is complete and now all four regional associations have ecommerce using NCWM's merchant services account for credit card processing.

Many members have expressed appreciation for the mobile-friendly version for searching and downloading NTEP Certificates of Conformance in the field via smart phones etc., noting that field officials probably visit that area of the website more often than any other. There was a suggestion that the website include a list of duties for each staff person and provide a welcome and introduction to new staff persons.

A member asked that all of the safety articles from past newsletters be posted in one location on the website for easier access to download. This request has been implemented and the articles may be accessed at: www.ncwm.net/resource/safety/articles.

Comments and suggestions for improvements to the newsletter and website should be directed to NCWM at (402) 434-4880 or info@ncwm.net.

Online Position Forum:

The purpose of the Online Position Forum is to help members prepare for the deliberations and voting at the Annual Meeting in July by having a better idea of positions others may have.

Activity on the site increased somewhat in the second year for the Online Position Forum, but it remains light. The Board believes that participation will increase in time as members become more comfortable with it and as committee agenda items generate interest. Improvements were made following the first experience in 2011 so that comments are more easily viewed.

The Online Position Forum is not a voting system. Comments and positions entered there are not binding. It is simply a method to present positions, opinions, and supporting documents. All active, associate, and advisory members have the opportunity to login, view committee agenda items, enter positions and comments, and even upload supporting .pdf documents for each agenda item of standing committees or the Board.

NCWM notifies members when the forum is ready for them to enter their comments each spring. The comment period will end on May 31. The options for each agenda item are:

- Support;
- Support with Comments;
- Oppose with Comments;
- Neutral; or
- Neutral with Comments.

Beginning in 2014, the Forum will be reconfigured so that members can view the comments and positions that others have submitted prior to submitting their own. However, the site is not a blog. Once a member submits positions, that member cannot submit more positions.

NEWMA supports continuing the Online Position Forum and remains hopeful that more members will participate in the future.

Social Networking:

Over the past year, NCWM has posted many news articles and other items of interest to the weights and measures community on the social networks. This has increased interest in the social network accounts with LinkedIn, Facebook, and Twitter. These accounts were formed to improve NCWM's outreach and raise awareness of our organization. By opening these accounts, NCWM is now more visible in internet search engines and will be more identifiable to tech-savvy stakeholders. They will find links to weights and measures related news stories and they will be kept informed throughout the Interim and Annual Meetings of special announcements including any changes in schedule. Members who participate in these social networks are encouraged to follow NCWM as a means of creating even more exposure with their friends and colleagues.

Compliments were offered to NCWM for posting links to pertinent news pieces related to weights and measures on the NCWM Facebook, LinkedIn, and Twitter accounts and to NIST for posting them to the Directors e-mail listserv.

Professional Certification Program:

Individuals may submit requests for NCWM Professional Certification Exams at www.ncwm.net. Exams are free for members and \$75 for non-members. The NCWM website is now fully integrated with the online testing service. As orders are received, the applicant receives an automated e-mail with credentials and instructions for accessing the exam. An applicant who does not pass the exam in the first attempt may have one retake. After that, it will be necessary to reapply.

NEWMA noted that the Professional Certification Program is a tremendous opportunity for training and education. Members are looking forward to additional exams.

Certification is now available in three areas, including:

- Retail Motor Fuel Dispensing Systems;
- Package Checking Basic; and
- Small Capacity Weighing Systems Class III.

See the Professional Development Committee Report for information on additional exams under development.

110-3 I Meetings Update

Interim Meetings:

- January 19 - 22, 2014 Hotel Albuquerque, Albuquerque, New Mexico
- January 18 - 21, 2015 Hilton Daytona Beach, Daytona Beach, Florida
- January 2016 Hotel to be selected in San Diego or Orange County, California

Annual Meetings:

- July 13 - 17, 2014 The Westin Book Cadillac Hotel, Detroit, Michigan
- July 19 - 23, 2015 Sheraton Society Hill Hotel, Philadelphia, Pennsylvania

NCWM strives to plan meetings in locations that offer comfortable rooms and a variety of entertainment and dining options close by. The following is a brief description of future planned events.

The 2014 Annual Meeting will be held at the Westin Book Cadillac Hotel in downtown Detroit, Michigan. This Italian Renaissance-style hotel is in the National Register of Historic Places. There are restaurants in the area to assure attendees of evening enjoyment.

The Board has selected Philadelphia, Pennsylvania, for the 100th NCWM Annual Meeting in 2015. The Sheraton Society Hill Hotel provides easy access to the rich history and evening food and entertainment.

The top three cities for the 2016 Interim Meeting were ranked in order of preference by the Board with San Diego, California; first, Orange County/Los Angeles, California, area; second, and Phoenix, Arizona; third. If there is enough competition in San Diego to secure desired rates, NCWM will limit site visits to that city.

100th NCWM Annual Meeting:

The Board hopes to make the 2015 Annual Meeting a very special event and one that you won't want to miss. In addition to addressing the business of the organization, NCWM will be celebrating its 100th Annual Meeting; 110 years after our first meeting in 1905. A small work group is developing plans for the 100th NCWM Annual Meeting in 2015. Originally, the Board looked at Washington, DC, Boston, Massachusetts, and Philadelphia, Pennsylvania, because of their historic significance. At NEWMA's request, proposals were also requested from Baltimore, Maryland. The final decision was the Sheraton Society Hill in Philadelphia. The Work Group will consider special events to commemorate and bring excitement to the occasion. Suggestions may be forwarded to Ms. Elisa Robertson, NCWM Office Manager, at (402) 434-4872 or elisa.robertson@ncwm.net.

110-4 I Participation in International Standard Setting**Conformity to Type**

International Organization of Legal Metrology (OIML) is considering development of a Conformity to Type (CTT) program. An OIML Seminar on CTT was held in June 2011 in Utrecht, The Netherlands. NCWM was invited to share its experience with the NTEP Conformity Assessment Program and in particular, the Verified Conformity Assessment Program (VCAP). The presentation was given by Mr. Onwiler, NCWM Executive Director. NCWM is hopeful that the VCAP Audit Reports can also satisfy the needs of the OIML CTT at a significant savings to certificate holders. Mr. Flocken, Mettler-Toledo, LLC, made a presentation with perspectives from the manufacturing industry. Dr. Ehrlich, National Institute of Standards Technology (NIST), Office of Weights and Measures (OWM), was in attendance and participated in the discussions. An OIML subcommittee has been formed to research and make recommendations on the development of an OIML CTT program.

Mutual Acceptance Arrangement (MAA)

Mr. Truex, NTEP Administrator, attended the Committee on Participant Review in Germany in 2011. Resolutions were developed at that meeting for the amendment of B10, the certificate system under the MAA. The spirit of the resolutions was to allow utilizing authorities to voluntarily accept manufacturer test data under the MAA. The resolutions were adopted in 2012. (See the NTEP Committee Interim Meeting Report for more detail and Board of Director's Report, Appendix A.)

Dr. Ehrlich, NIST, OWM, gave a report of OIML activities at the 2013 NCWM Interim Meeting. Mr. Ralph Richter gave a report of the OIML activities at the 2013 NCWM Annual Meeting in Louisville, Kentucky. This report is included as an Appendix A to the Report of the Board of Directors

110-5 I Associate Membership Committee (AMC) Activity

The Associate Membership Committee is organized in accordance with the Bylaws of the National Conference on Weights and Measures, Inc. In addition, AMC operates by its own Bylaws which are available on the Committee pages of www.ncwm.net. AMC meets at least two times per year in conjunction with NCWM Interim and Annual Meetings. It consists of between 5 and 10 members who, amongst themselves, elect officers to serve as Chairman, Vice Chairman, and Secretary/Treasurer. AMC has established a reputation of promoting and improving NCWM and has demonstrated its desire to improve understanding of weights and measures activities in public and private sectors.

The membership dues for Associate members (\$90) are higher than that for Active or Advisory members (\$75). The extra \$15 is not for NCWM, but rather is placed in a separate account referred to as the AMC Training Fund. AMC receives applications and awards training scholarships in accordance with their "Guidelines for Selection and Approval of Training Funds" that are posted on the Committee's portion of www.ncwm.net. Downloadable scholarship applications and reimbursement forms are also available there or applications may be made online.

AMC training fund selection criteria are as follows:

1. Training fund request forms that are complete, specific, and detailed will receive priority attention for approval. Based on the degree of missing or ambiguous information provided, individual requests may not be given any consideration during the AMC review process.
2. Training requests that benefit higher numbers of participants are generally preferred over those for fewer or single-person benefit. Multi-state training that encourages uniformity will also be given priority consideration.
3. In general, attending meetings will not be considered training, especially requests for travel expense or attendance fees for NCWM Annual, Interim, or Regional meetings.
4. As a lower priority, requests for the purchase of training materials will be considered, but requests for purchase of assets (such as LCD projectors) will not.
5. Reasonable funding for travel and expenses will be considered if it is necessary to acquire an "expert trainer" that would benefit a high number of weights and measures officials. This will be an option when qualified volunteers are not available.

Members of AMC have become concerned that the funds are underutilized in recent years. Regulatory agencies are encouraged to make use of these funds to improve training opportunities and the expertise of inspection personnel.

AMC members are also looking for new, perhaps innovative ways to play a more effective role in the NCWM structure in an effort to further improve the organization. Some new initiatives that AMC is discussing include:

- **Promotional Tool-Kit:** AMC has offered funds to assist NCWM in creating a "tool kit" that weights and measures administrators could use to improve awareness and support through adequate funding of their programs. This tool kit could consist of many elements for targeting media, consumers, government administrators, and legislators. AMC has proposed a work group to pursue this project.
- **Tradeshaw Seminars:** AMC is interested in organizing training or awareness seminars at industry type tradeshaws with the idea of reaching out to the smaller industry groups that are impacted by the work of NCWM. This effort would be good for the smaller industries as well as providing possible increase in NCWM membership and participation.

AMC meetings are open to all registered NCWM meeting attendees. All Associate Members are encouraged to attend these meetings, become familiar with the Committee, and offer ideas for how it can further pursue its objectives. (See Appendix B of the Board report for the AMC Meeting Minutes.)

The NEWMA Board of Directors has expressed appreciation specifically for the support that the AMC has provided through training funds, and they look forward to the development of the Promotional Toolkit.

120 STRATEGIC PLANNING, POLICIES, AND BYLAWS

120-1 I Strategic Planning

The Executive Director presents a strategic plan progress report each year at the fall Board meeting. The Board conducts a strategic planning session in January at its quarterly meeting just prior to the Interim meeting. The Board made several updates and changes to the Strategic Plan in January 2013. Members are able to review the Strategic Plan at online at www.ncwm.net. NEWMA has pledged assistance for NCWM to achieve its goals. The Board welcomes member input.

Five NCWM Strategic Plan Goals:

1. Enhance NCWM as a national and international resource for measurement standards development.
2. Expand the role of NCWM as a resource for state and local weights and measures programs.
3. Promote uniform training for individuals involved in weights and measures.
4. Continue to improve NTEP.
5. Preserve the financial stability of NCWM.

NCWM as a National and International Resource:

Strategy 1: This goal was initially to implement the Online Position Forum. That was completed in 2011 and the strategy is now to make improvements to the program and promote increased use of it by our membership. Several ideas have been implemented to generate interest. Additionally, guidance has been developed to assist committees in how to preview and use comments in a consistent manner.

The following new strategies were added to this goal:

Strategy 2: Identify, communicate and collaborate with other regulatory, industry, and standards development organizations, foreign and domestic, to strengthen awareness of NCWM and draw on mutual resources toward mutual goals.

Strategy 3: Increase consumer group participation in NCWM through outreach efforts.

Expand the Role of NCWM as a Resource to Officials:

Initially, a strategy under this goal was to conduct annual surveys of the states to gather specific information for benchmarking purposes. In 2013, the strategy was modified to provide flexibility on the frequency and subject matter for surveys.

Many programs are experiencing severe budget cuts that are diminishing their effectiveness. The AMC has expressed interest in assisting with the development of a “tool kit” that can be used by program administrators to generate awareness and support for their programs. This toolkit will contain materials including data supporting a regulatory presence, industry contacts that can be called upon to explain the necessity of a regulatory presence to ensure a level playing field for businesses and consumer protection, and a short video production.

Promote Uniform Training:

The Professional Certification Program is a top priority under this goal. Two new exams were added in 2012 and several more are in development. Mr. Ross Andersen continues to serve as Certification Exam Coordinator working with the PDC and subject matter experts. The Board believes this arrangement will greatly assist the PDC in developing a full line of certification exams.

Some states are expressing interest in using the Professional Certification Program as a prerequisite to registering/licensing service agents. There is discussion that the exams may be more difficult for service agents who have not received the level of Handbooks 44 (*Specifications, Tolerances, and Other Technical Requirements for*

Weighing and Measuring Devices), 130 (*Uniform Laws and Regulations in the Areas of Legal Metrology and Engine Fuel Quality*), and 133 (*Checking the Net Content of Packaged Goods*) training that regulatory officials receive. If the exams are too difficult, it could provide a costly delay to service agencies that are trying to establish employees as qualified to work independently and with the privileges of being registered or licensed. The counter argument would be that the Professional Certification Program should elevate concerns over the quality of service agents as well as regulatory officials. See more discussion on this in the PDC report.

Several amendments were made to the various strategies in this goal and a new strategy was added to create a national directory of weights and measures officials at all levels of government. NCWM will need to determine an effective method to compile the information.

Continue to Improve NTEP:

NCWM surveyed regulatory officials this past year to determine how they access NTEP Certificates of Conformance in the field. This will be used as a benchmark. As technology advances, NCWM will have a better understanding for how it can make Certificates of Conformance more accessible. In 2013, NCWM will offer a mobile friendly version of the website which will benefit those who access the NTEP database with their smart phones.

A strategy of high priority under this goal is to maintain viable support for NTEP laboratories. Mr. Truex, NTEP Administrator, monitors the number of full-time equivalents associated with the authorized laboratories and tracks evaluation time and backlog statistics to ensure that NTEP evaluations can be completed in a timely manner. He reports these statistics quarterly to the NTEP Committee and Board of Directors.

NCWM has a contingency plan in place to ensure evaluation services are maintained for NTEP applicants in the event that insufficient services were available under the current authorized laboratory system. The Board is monitoring its available resources toward that end in hopes that NCWM will eventually be in a position to implement the worst-case scenario, should the need arise. Another strategy toward this goal is the continued development of the Verified Conformity Assessment Program which has already successfully addressed load cells and has moved on to the next device-type category. (See the NTEP Committee Report for more details.)

Preserve Financial Stability:

This goal was originally to “ensure” financial stability. Financial reports of the past several years indicate that NCWM is financially stable barring any unexpected circumstances. However, NCWM must recognize that it does not have sufficient reserves at this time to fully implement the NTEP contingency plan that was developed to ensure continued evaluation services if the authorized state laboratories fell victim to budget cuts. The Board has studied NCWM’s needs for reserves for NTEP and other potential exposures. This is being balanced with continued efforts to improve services in support of customers and membership. NCWM finances are reviewed annually.

120-2 I Regional Support

Meeting Documents on Regional Websites:

In the fall of 2011, NCWM made efforts to be the clearinghouse for all new proposals being submitted to the regional associations. Since then, staff has been looking for ways to further streamline the process while improving documents, reports, and communication. NCWM provides the regional committees with a report template that contains all of the regions carryover items and new proposals. The templates are improved each year based on feedback and efforts to streamline the reporting process for everyone.

The report templates in 2013 have been modified based on extensive discussions at the 2012 Committee Orientation sessions. Regional committees should find them to be less confusing for presenting the discussions, recommendations, and regional decisions. NEWMA committee chairs expressed that the process is now much easier to work with and also members have a clearer understanding of the issues. Downloading agenda items for interim and annual meetings is made much easier. They also stated that the new format for NCWM Publication 15 works very well and the deadline works well.

All of the regional websites are hosted through NCWM. NCWM has worked in recent years with the website company to add ecommerce to the regional websites using NCWM’s merchant services to process credit card

payments. This additional programming is at the regions' expense, but there is no additional administrative fee above the standard flat rate of \$200 per year assessed by NCWM to provide support. As of 2013, all four regions have now added the ecommerce option for online meeting registrations and membership dues (where applicable).

NEWMA Board of Directors expressed appreciation for the efforts of NCWM staff to update regional websites for all committee issues and making the process of filling out Form 15 for submitters much easier and clearly understood.

120-3 I Standing Committees Support

Committee Orientation:

NCWM conducts Committee Orientation for committee chairs and new committee members every fall at NIST, OWM in Gaithersburg, Maryland. The location enables full participation by all NIST Technical Advisors. The focus is on leadership, administrative processes, roles and responsibilities, and review of *NCWM Committee Handbook*. Additionally, the Committee chairs and NIST Technical Advisors review agenda items for the new members so that they are prepared in advance for the technical discussions and Open Hearings.

At the 2012 Committee Orientation, additional improvements were made to the *NCWM Committee Handbook* and to the report templates that regional committees use to submit their reports for inclusion in NCWM Publication 15.

Task Groups, Subcommittees, Steering Committees:

Task groups, subcommittees and steering committees are created by appointment by the NCWM Chairman. A task group is given a specific charge and it reports to the appropriate NCWM standing committee. A task group will disband at the completion of its assignment. A subcommittee is charged with ongoing responsibilities in support of a standing committee in a specific field of expertise. A steering committee is charged with unbiased fact-finding that will assist NCWM membership in decision processes for difficult issues. A steering committee will disband upon completion of its specific charge.

NCWM offers resources to these task groups and subcommittees including meeting space at Interim and Annual Meetings, conference calling and web meeting services, dedicated e-mail listservs, a dedicated web page for posting and archiving documents related to their work, and broadcast e-mail services to reach targeted audiences. Additionally, NIST, OWM has provided technical advisors and web meeting forums. All of these tools enable year-around progress of task group and subcommittee work.

Because NCWM task groups and subcommittees report directly to NCWM Standing Committees or Board of Directors, any new proposals may appear in NCWM Publication 15 without first being vetted through a regional association. Any such proposals are properly vetted through the open hearings of NCWM. This structure enables more efficient standards development.

Two new groups are being established this year; the Promotional Tool Kit Task Group and the Natural Gas Steering Committee. Descriptions are provided below.

The Board expresses great appreciation to the volunteers who serve in support of the work of this organization.

- **Natural Gas Steering Committee (NEW):**

The Laws and Regulations (L&R) Committee heard spirited debate at the 2013 Interim Meeting Open hearings on a proposal to recognize the Diesel Gallon Equivalent and Diesel Liter Equivalent as the method of sale for compressed and liquefied natural gas; similar to the Gasoline Gallon and Liter Equivalents that were recognized in 1994. Opponents argue that a method of sale by mass is preferred.

NCWM Chairman Stephen Benjamin formed a new Natural Gas Steering Committee to address rising issues as the compressed and liquefied natural gas markets rapidly expand. The Steering Committee will report to the Laws and Regulations Committee. Its charge is to gather information that will assist NCWM Membership in the decision process as model standards are developed for the sale of compressed natural gas.

Chair

Mr. Mahesh Albuquerque
CDLE- Oil and Public Safety
Denver, CO
E-mail: mahesh.albuquerque@state.co.us

- **Promotional Tool Kit Task Group (NEW):**

This group will develop tools that may be used by weights and measures agencies to promote awareness and support and adequate funding for their programs. The tools will target three separate audiences:

- Consumers;
- Regulated Industries; and
- Legislators, Governors, and Agency Administrators.

Tools may include case studies, data, short-segment video productions, public service announcements, etc.

Chair

Mr. Stephen Benjamin
North Carolina Department of Agriculture
Raleigh, NC
E-mail: steve.benjamin@ncagr.gov

- **Weights and Measures Training Manual Task Group:**

This new group reports to the PDC and is assigned to develop a training manual that can be used to ensure proper training methods and evaluation of training success for all aspects of field enforcement.

Chair

Mr. Michael Cleary
Retired
Sacramento, CA
E-mail: mcleary55@sbcglobal.net

- **Retail Motor Fuel Dispenser Price Posting and Computer Capability Task Group:**

The group reports to the Specifications and Tolerances (S&T) Committee and is developing specifications for multi-tier and discount pricing at retail. For more information, contact:

Chair

Ms. Fran Elson-Houston
Ohio Department of Agriculture
Division of Weights and Measures
8995 East Main Street
Reynoldsburg, OH 43068
Phone: (614) 728-6290
Fax: (614) 728-6290
E-mail: houston@agri.ohio.gov

- **Fuels and Lubricants Subcommittee:**

This group reports to the L&R Committee. For more information, contact:

Chair

Mr. Ronald Hayes
Missouri Department of Agriculture
1616 Missouri Blvd
P.O. Box 630
Jefferson City, MO 65102
Phone: (573) 751-4316
Fax: (573) 751-0281

E-mail: ron.hayes@mda.mo.gov

- **Packaging and Labeling Subcommittee:**
The group reports to the L&R Committee. For more information, contact:

Chair

Mr. Christopher Guay
Procter and Gamble, Co.
One Procter and Gamble Plaza
Cincinnati, OH 45202
Phone: (513) 983-0530
Fax: (513) 983-8984
E-mail: guay.cb@pg.com

NEWMA reported appreciation from a member regarding the formation of the Packaging and Labeling Subcommittee as this is an area of weights and measures focus has been sidetracked due to budget issues.

120-4 V Section L. Classifications for Agenda Items, Section M. Developing Items

(This item was adopted.)

Source:

NCWM Board of Directors (2013)

Purpose:

Clarify definitions of agenda item status designations.

Item Under Consideration:

Amend NIST Handbook 44, *Specifications, Tolerances, and Other Technical Requirements for Weighing and Measuring Devices* and NIST Handbook 130, *Uniform Laws and Regulations in the Areas of Legal Metrology and Engine Fuel Quality* Introduction as follows:

L. Classifications for Agenda Items.

At the Interim Meeting, the Committee ~~can~~will classify proposals in one of the following ways as:

1. "Voting" – ~~these are items proposed for a vote by the NCWM membership and are indicated with a "V" after the item number in the agenda~~ These are items the Committee believes are fully developed and ready for final consideration of the voting membership. Each item has either received majority support from the Committee or the Committee has reached agreement that it is ready for voting status to let NCWM membership decide. The Committee has the ability to remove items from the voting agenda at the Annual Meeting by changing the status prior to a vote of the NCWM membership. The Committee may amend voting items during the course of the Annual Meeting based on additional information received following the Interim Meeting and testimony received at the Annual Meeting. These items may also be amended by the voting membership during the voting session of the Annual Meeting following the procedures outlined in the NCWM Bylaws; or
2. "Informational" – ~~these are items which require further study, comment, and development and are indicated with an "I" after the item number in the agenda~~ These items are deemed by the Committee to have merit. They typically contain a proposal to address the issue at hand and a meaningful background discussion for the proposal. However, the Committee wants to allow more time for review by stakeholders and possibly further development to address concerns. The committee has taken the responsibility for any additional development of Informational items. For particularly difficult items, the Committee may assign the item to an existing subcommittee under its charge or request that the NCWM Chair appoint a special task group

that reports to the Committee. At the Annual Meeting, the Committee may change the status of the items, but not to Voting status because the item has not been published as such in advance of the meeting; or

3. “Developing” - These items are deemed by the Committee to have merit, but are found to be lacking enough information for full consideration. Typically the item will have a good explanation of the issue, but a clear proposal has yet to be developed. By assigning Developing status, the Committee has sent the item back to the source or assigned it to some other entity outside the scope of the Committee with the responsibility of further development. The Committee Report will provide the source with clear indication of what is necessary to move the item forward for full consideration. The item will be carried in the Committee agenda in bulletin board fashion with contact information for the person or organization that is responsible for the development. Since the Committee is not required to receive testimony on developing items, this status should be carefully implemented so as not to weaken the standards development process; or
34. “Withdrawn” – these are items which will no longer be considered by the Committee and are indicated with a “W” after the item number in the agenda. These are items that the Committee has found to be without merit. The committee's determination to withdraw should not be based on the Committee's opinion alone, but on the input received from stakeholders. The committee's report will contain an explanation for the withdrawal of the item. Once an item appears in NCWM Publication 16 as Withdrawn, the status of that item may not be amended. The item may be reintroduced through the regional associations for consideration as a new item.

M. Developing Items.

~~In the past the Committee had either carried undeveloped proposals forward as informational, or withdrawn them. Conference members felt that carrying undeveloped informational items on its agenda for years posed an unnecessary drain on NCWM resources. Alternatively, the Conference was also concerned that withdrawing items prematurely resulted in the Committee discarding valuable work that had gone into identifying and presenting the items. NCWM was also interested in providing a mechanism to inform parties about items that were developing in different localities or in the regional associations.~~

~~At the 1998 Annual Meeting, NCWM established a process for disseminating information on items that may have merit but are insufficiently developed for Committee action. NCWM established a new “Developing” designation to allow the Committee to notify the submitter that while this item may have merit, it has not been adequately developed for action at the national level. NCWM agreed that developing items should be submitted by the regional associations with a recommendation that they be presented as “D” items on the national agenda.~~

~~The Committee will present “D” items in list format at the end of its report and include a point of contact (including the name and telephone number of the submitter) so that interested parties can obtain additional information. No comments will be taken on a developing item unless the Committee agrees to receive the new information in advance of the hearing. In these cases, the Chairman will announce in advance that an item will be discussed in the session. The use of this “D” designator is seen as an item management tool, as well as a way to keep the membership informed of emerging items.~~

(Re-letter remaining sections)

Background/Discussion:

There is inconsistency in understanding among NCWM members and regional associations of the purpose and impact of recommending or assigning an item status to an agenda item. The NCWM Board of Directors discussed the various status designations and developed additional guidance for use by NCWM standing committee members.

That guidance is now part of the *NCWM Committee Handbook*, has been presented to committee members at fall orientation sessions, and has been refined as a result of those meetings with the help of committee chairs and NIST technical advisors.

An example of this clarification is the distinction between “Developing” items and “Informational” items. For “Developing” items, the Committee is not responsible for Developing the item and has assigned that responsibility to some person or organization outside of the Committee; usually the source. Items designated as “Informational” may also require development, but the Committee is taking responsibility for the item, either directly or through a subcommittee or task group appointed by the NCWM Chair that reports directly to the Committee.

Committee members understand that items designated as “Informational” or “Developing” in NCWM Publication 16 cannot be upgraded to “Voting” status that same year. In the course of those discussions, it has been suggested that an item designation of “withdrawn” by a committee following the NCWM Interim Meeting may be upgraded by the Committee to “Informational” or “Developing” at any time prior to adoption of the Committee’s final report at the NCWM Annual Meeting. These matters are not specifically addressed in NCWM policy and have sparked concern and discussion. The Board proposes including additional guidance in the Introduction section of NIST Handbooks 44 and 130 in an effort to improve understanding and application of item status recommendations by regional associates and NCWM standing committees.

NCWM committee members are told in orientation and in the *NCWM Committee Handbook* that they “own” an item right up to the point where there is a call for a vote. However, it is not standard practice to modify the status of a withdrawn item after that designation is established by the Committee in January. Once a committee designates an item as withdrawn, stakeholders may discontinue paying attention. The Board is concerned that a policy allowing that status to be reversed prior to adoption of the report in July may cause the Committee to be subjected to undue pressure. The Board proposes as part of this amendment to clarify that Withdrawn items must remain Withdrawn. If an item does have merit, it may be reintroduced through the regions in the fall as a new item.

Members expressed that the language should be the same in both NIST Handbooks 44 and 130. The proposed language clearly relates the current interpretation of the definitions.

At the 2013 Annual Meeting, the Board modified the proposal to avoid unintended consequences for items that are changed to Withdrawn at an Annual Meeting. The originally proposed version of new Section L, paragraph 4 was as follows:

34. “Withdrawn” – ~~these are items which will no longer be considered by the Committee and are indicated with a “W” after the item number in the agenda~~These are items that the Committee has found to be without merit. The committee's determination to withdraw should not be based on the Committee's opinion alone, but on the input received from stakeholders. The committee's report will contain an explanation for the withdrawal of the item. Once an item appears in NCWM Publication 16 or the Annual Meeting addendum sheets as Withdrawn, the status of that item may not be amended. The item may be reintroduced through the regional associations for consideration as a new item.

The Board removed the phrase, “or the Annual Meeting addendum sheets” from the proposal, commenting that a Committee decision at an Annual Meeting to change the status of an item to Withdrawn should not be a final decision until the Committee report is adopted. Prior to that vote, the Committee itself may change its mind or the voting membership may amend the item.

130 FINANCIALS

130-1 I Financial Report

NCWM operates on a fiscal year of October 1 through September 30. Budgets are set to be conservative on projected revenues and realistic on anticipated expenses.

Below is a graphic view of past 10 fiscal years based on year-end audit reports. The spike in expenses in 2008 reflects the cost transition from contracted management services to hired employees and, procured office space, furniture, computers, etc. The graph shows significant savings in the following years of 2009 - 2011 even though NCWM has invested significantly in new initiatives during that time. Those initiatives include NCWM and regional website development, the Online Position Forum, the Professional Certification Program, and other improvements to services. The Board of Directors continues to monitor its ability to fully implement contingency plans based on potential costs compared to reserve funds.

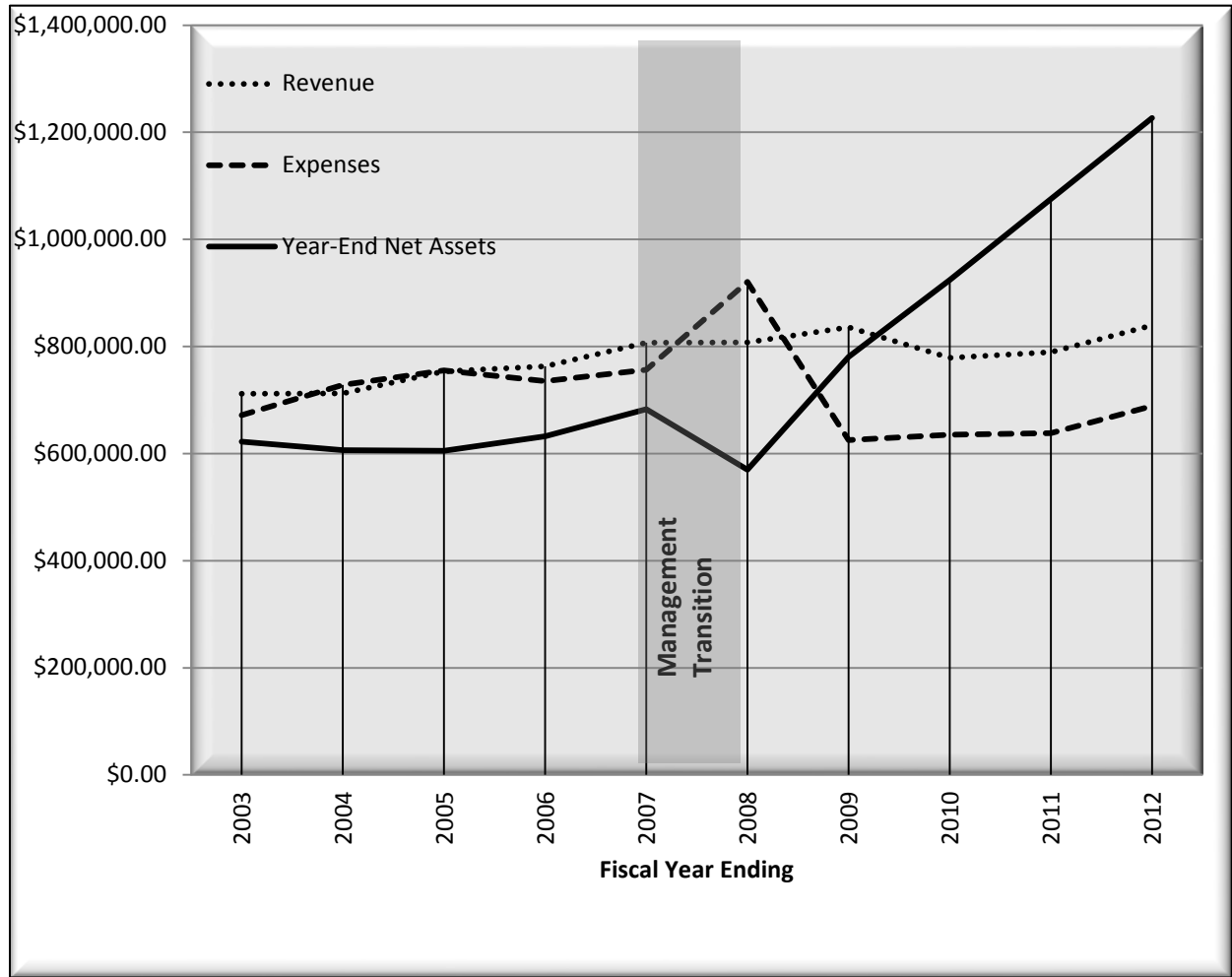

The following is the balance sheet as of March 31, 2013, in comparison with the same time the previous year. Assets in the balance sheet are inflated by the NIST Training Initiative Grant that was awarded to NCWM later in 2012. Those funds are earmarked for specific training activities. Assets are also inflated by the Associate Membership Fund. This money is accumulated through the additional \$15 dues paid by NCWM Associate Members and is spent at the discretion of the Associate Membership Committee in accordance with Committee Bylaws.

ASSETS	<u>June 30, 2013</u>	<u>June 30, 2012</u>
Current Assets	\$	\$
Checking/Savings		
Associate Member Fund	26,602.49	20,626.30
NIST Training Grant	52,253.27	0.00
Certificates of Deposit	1,149,123.91	1,126,348.07
Checking	35,697.28	34,796.11
Savings	194,742.49	129,601.52
Total Checking/Savings	<u>\$ 1,458,419.44</u>	<u>\$ 1,311,372.00</u>
Accounts Receivable	145.78	10.00
Other Current Assets	27,165.24	38,808.22
Other Assets	11,889.11	7,352.30
TOTAL ASSETS	<u>\$ 1,497,619.57</u>	<u>\$ 1,357,542.52</u>
LIABILITIES & EQUITY		
Liabilities		
Current Liabilities	19,747.93	21,499.43
Total Liabilities	<u>19,747.93</u>	<u>21,499.43</u>
Equity		
Unrestricted Net Assets	1,243,897.98	1,095,673.51
Net Income	233,973.66	240,369.58
Total Equity	<u>1,477,871.64</u>	<u>1,336,043.09</u>
TOTAL LIABILITIES & EQUITY	<u>\$1,497,619.57</u>	<u>\$ 1,357,542.52</u>

Mr. Stephen Benjamin, North Carolina | Chairman
 Mr. John Gaccione, Westchester County, New York | Chairman-Elect
 Mr. Kurt Floren, Los Angeles County, California | NTEP Committee Chair
 Mr. Mark Coyne, City of Brockton, Massachusetts | Treasurer
 Mr. Jerry Buendel, Washington | Active Membership - Western
 Mr. Ronald Hayes, Missouri | Active Membership - Central
 Mr. Terence McBride, Memphis, Tennessee | Active Membership - Southern
 Mr. James Cassidy, City of Cambridge, Massachusetts | Active Membership - Northeastern
 Mr. Stephen Langford, Cardinal Scale Manufacturing, Co. | At-Large
 Mr. Steve Giguere, Maine | At-Large
 Mr. Gordon Johnson, Gilbarco, Inc. | Associate Membership

Ms. Carol Hockert, NIST, OWM | Executive Secretary
 Mr. Don Onwiler, NCWM Headquarters | Executive Director
 Mr. Gilles Vinet, Measurement Canada | Board of Directors Advisor
 Mr. Jim Truex, NCWM Headquarters | NTEP Administrator

Board of Directors

THIS PAGE INTENTIONALLY LEFT BLANK

Appendix A

Report of the Activities of the International Organization of Legal Metrology (OIML) and Regional Legal Metrology Organizations

National Institute of Standards and Technology (NIST), Office of Weights and Measures (OWM)

INTRODUCTION

The NIST, OWM is responsible for coordinating United States participation in OIML and other international legal metrology organizations. Learn more about OIML at www.oiml.org and about NIST, OWM at www.nist.gov/owm. Dr. Charles Ehrlich, Program Leader of the International Legal Metrology Program, can be contacted at (301) 975-4834 by fax at (301) 975-8091 or charles.ehrlich@nist.gov.

Note: OIML publications are available without cost at www.oiml.org.

Table A
Table of Contents

Title of Content	BOD – A Page
INTRODUCTION	1
I. REPORT ON THE ACTIVITIES OF THE OIML TECHNICAL COMMITTEES	3
TC 3/SC 5 Conformity Assessment (United States)	3
TC 5/SC 1 Environmental Conditions (Netherlands)	3
TC 5/SC 2 Software (Germany and BIML)	3
TC 6 Prepackaged Products (South Africa)	3
TC 8 Measurement of Quantities of Fluids (Japan)	4
TC 8/SC 1 Static Volume and Mass Measurement (Germany)	4
TC 8/SC 3 Dynamic Volume and Mass Measurement for Liquids Other Than Water (United States and Germany)	4
TC 8/SC 5 Water Meters (United Kingdom)	5
TC 8/SC 6 Measurement of Cryogenic Liquids (United States)	5
TC 8/SC 7 Gas Metering (Netherlands)	5
TC 17/SC 8 Quality Analysis of Agricultural Products (Australia)	6
OIML Mutual Acceptance Arrangement (MAA)	6
II. REPORT ON THE 47TH CIML MEETING IN BUCHAREST, ROMANIA IN OCTOBER 2012.....	6
III. REPORT ON THE 14TH OIML CONFERENCE IN BUCHAREST, ROMANIA, IN OCTOBER 2012	7
IV. FUTURE OIML MEETINGS	8
V. REGIONAL LEGAL METROLOGY ORGANIZATIONS.....	8

Table B
Glossary of Acronyms and Terms

Acronym	Term	Acronym	Term
ANSI	American National Standards Institute	ISO	International Standardization Organization
APEC	Asia-Pacific Economic Cooperation	IWG	International Work Group
APLMF	Asia-Pacific Legal Metrology Forum	LMWG	Legal Metrology Work Group
APMP	Asia-Pacific Metrology Program	MAA	Mutual Acceptance Agreement
B	Basic Publication	MTL	Manufacturers' Testing Laboratory
BIML	International Bureau of Legal Metrology	NIST	National Institute of Standards and Technology
BIPM	International Bureau of Weights and Measures	NTEP	National Type Evaluation Program
CD	Committee Draft ¹	OIML	International Organization of Legal Metrology
CIML	International Committee of Legal Metrology	OWM	Office of Weights and Measures
CTT	Conformity to Type	PG	Project Group
D	Document	R	Recommendation
DD	Draft Document ²	SC	Technical Subcommittee
DoMC	Declaration of Mutual Confidence	SIM	Inter-American Metrology System
DR	Draft Recommendation ²	TC	Technical Committee
DV	Draft Vocabulary ³	USNWG	U.S. National Work Group
GA	General Assembly	VIM	International Vocabulary of Metrology
IEC	International Electrotechnical Commission	VIML	International Vocabulary of Legal Metrology
IQ Mark	International Quantity Mark	WD	Working Draft ³
<p>¹ CD: a draft at the stage of development within a technical committee or subcommittee; in this document, successive drafts are numbered 1 CD, 2 CD, etc.</p> <p>² DD, DR, and DV: a draft document approved at the level of the technical committee or subcommittee concerned and sent to BIML for approval by CIML</p> <p>³WD: precedes the development of a CD; in this document, successive drafts are number 1 WD, 2 WD, etc.</p>			

Details of All Items
(In order by Reference Key)

I. REPORT ON THE ACTIVITIES OF THE OIML TECHNICAL COMMITTEES

This section reports on recent activities and the status of work in the OIML Technical Committees (TCs), Technical Subcommittees (SCs), and Project Groups (PGs) of specific interest to members of the National Conference on Weights and Measures (NCWM). Schedules of future activities of the TC/SC Secretariats, PG Convenors, the U.S. National Work Groups (USNWGs), and the International Work Groups (IWGs) and Project Groups of the TCs and SCs are also included.

TC 3/SC 5 Conformity Assessment (United States)

The OIML Basic Publications B 3 *Certificate System* and B 10 *Mutual Acceptance Arrangement (MAA)* were recently revised to incorporate updated practices, and to provide full consistency (including terminology) between the two documents. At the International Committee of Legal Metrology (CIML) Meeting in Bucharest, Romania, in October 2012 an Amendment to B 10 was approved that allows for the voluntary use of test data from manufacturer's test laboratories (MTLs) under specially supervised conditions. A Workshop is planned for the 2013 CIML Meeting (in Vietnam) to gather experiences of the various users and other stakeholders in the MAA. The 2nd Committee Draft (2 CD) of a new OIML document entitled *The Role of Measurement Uncertainty in Conformity Assessment Decisions in Legal Metrology* is under development by the Secretariat. Please see the MAA section in the National Type Evaluation Program (NTEP) Committee Report of this publication for more details on the activities of TC 3/SC 5. For more information on the activities of this subcommittee, please contact Dr. Charles Ehrlich at (301) 975-4834 or charles.ehrlich@nist.gov.

TC 5/SC 1 Environmental Conditions (Netherlands)

The Secretariat distributed the 2 CD revision of OIML Document D 11 *General requirements for measuring instruments - Environmental conditions*, in January 2012. This is a very important document in the OIML system and is used by all of the OIML TCs as a general reference for technical and testing requirements on all measuring instruments. The United States submitted comments on the 2 CD in March 2012. Before distribution of the 2 CD, the United States participated in a meeting of TC 5/SC 1 to discuss the D 11 document in Utrecht, The Netherlands. Highlights of the discussions in Utrecht included: expanding the terminology section, updating several testing sections to reflect the latest International Electrotechnical Commission (IEC) reference standards, and including a new environmental class ("E3") for a non-mains local source of electrical power supply. The OIML Expert Report E 5 *Overview of the Present Status of the Standards Referred to in OIML D 11 – General Requirements for Electronic Measuring Instruments* was recently published and updates all of the IEC references for testing requirements in D 11. The DD of D 11 passed its CIML preliminary ballot in December 2012. It is expected that this new revision of D 11 will be approved by the CIML and be published later in 2013. Please contact Mr. Ralph Richter at (301) 975-3997 or ralph.richter@nist.gov, if you would like further information on this project.

TC 5/SC 2 Software (Germany and BIML)

The OIML D 31 *General Requirements for Software-controlled Measuring Instruments* has been published and will serve as guidance for software requirements in International Recommendations by OIML TCs. The United States participated in the technical work on this document and submitted votes and comments on several drafts of the document. A new project on software verification was approved by CIML, and the United States is waiting for the first draft of this document. Please contact Dr. Ambler Thompson at (301) 975-2333 or ambler@nist.gov if you would like to discuss OIML software efforts.

TC 6 Prepackaged Products (South Africa)

After an online CIML vote was conducted, it was decided that the TC 6 project to develop an OIML International Quantity Mark (IQ Mark) would be terminated. The United States had already voted in favor of terminating this

project on the grounds that the effort to manage and certify quality control systems would have added unnecessary extra costs, with no value added, to all participating suppliers. At the same time, another CIML vote (same deadline) was conducted on a proposal for a new TC 6 project *Guidance for defining the system requirements for a certification system for prepackages*. The United States voted against this proposal on the grounds that even such an OIML Guidance Document could be construed as endorsing an OIML IQ Mark program. The results of the CIML vote on this proposal, and the best way forward are still being decided.

A meeting of TC 6 was held in Tokyo, Japan, in October 2012. Besides the IQ Mark project, two other important projects were heavily discussed: a revision of OIML Recommendation (R) 87 *Quantity of Product in Prepackages* (the OIML equivalent to NIST Handbook 133, *Checking the Net Contents of Packaged Goods*) and a revision of OIML R 79 *Labeling Requirements for Prepackaged Products*. The NIST Statistical Engineering Division (SED) has been participating in a small ad-hoc work group to improve the statistics in R 87. A 1st Committee Draft of R 87 has been developed and circulated for comment by the Secretariat. Also, the Secretariat has developed and circulated for comment a 3rd Committee Draft of R 79. The comment period for both of these CDs ended in March 2013. Both drafts contain proposed revisions that NIST OWM believes are unnecessarily complex, and, therefore, subject to easy misinterpretation, and another that appeared to go beyond the scope of package labeling requirements. After consulting with the Chairman of the NCWM Packaging and Labeling Subcommittee about the proposed revisions to both R 87 and R 79, the United States voted “no” on R 79 (votes are not taken on 1st Committee Drafts, so only comments were submitted on R 87). The main reason for opposing both drafts is that they include proposed definitions for prepackage, packaging material, and product that are likely to result in confusion for consumers and packers alike.

For more information on the activities of this subcommittee, and to participate in the U.S. review of these CDs, please contact Mr. Ken Butcher at (301) 975-4859 or kbutcher@nist.gov.

TC 8 Measurement of Quantities of Fluids (Japan)

The CIML has approved projects to revise the following TC 8 documents: R 63 *Petroleum Measurement Tables* (1994) and R 119 *Pipe Provers for Testing of Measuring Systems for Liquids Other Than Water* (1996). Both of these documents are important for other OIML recommendations involving liquid measurement. Please contact Mr. Ralph Richter at (301) 975-3997 or ralph.richter@nist.gov, if you would like copies of the documents or to participate in any of these projects.

TC 8/SC 1 Static Volume and Mass Measurement (Germany)

The United States chairs the Project Group that is drafting new sections of OIML R 71, *Fixed Storage Tanks* and R 85, *Automatic Level Gages for Measuring the Level of Liquid in Fixed Storage Tanks* to add specific requirements for specialized tanks. OIML R 80-2, *Road and Rail Tankers, Test Methods*, is being developed by Germany. Please contact Mr. Ralph Richter at (301) 975-3997 or ralph.richter@nist.gov, if you would like to receive copies of the documents, or to participate in any of these projects.

TC 8/SC 3 Dynamic Volume and Mass Measurement for Liquids Other Than Water (United States and Germany)

Subcommittee work is continuing on the development of OIML R 117-2, *Dynamic Measuring Systems for Liquids Other Than Water, Part 2, Test Methods*, and R 117-3, *Test Report Format*. New annexes for measuring systems for foaming potable liquids, for pipelines, and for aircraft refueling are being developed. The Project Group for the development of R 117 also continues to hold international web-meetings to accelerate the work on this high priority document.

A meeting of the full TC 8/SC 3 subcommittee was hosted by the European Committee of Manufacturers of Petroleum Measuring Systems (CECOD) and the Syndicat de la Mesure at their Paris headquarters in November 2012. The subcommittee meeting was attended by 31 participants, including official representatives from 15 countries. Additionally, several representatives of major manufacturers of these systems and liaison organizations actively participated in the meeting. These technical experts provided a depth of experience and technical expertise that proved highly valuable during the meeting. The 2 CD of R 117-2 is planned to be

distributed in April 2013, and a meeting of the R 117 Project Group will be held October 1 - 3, 2013, in London, England. If you have any questions or would like to participate in the next phases of this project, please contact Mr. Ralph Richter at (301) 975-3997 or ralph.richter@nist.gov.

TC 8/SC 5 Water Meters (United Kingdom)

OIML, the International Standardization Organization (ISO), and the European Committee for Standardization (CEN) are working together to harmonize requirements for water meters using OIML R 49, *Water Meters Intended for the Metering of Cold Potable Water and Hot Water Parts 1, 2, and 3* as the base document. The 3 CD of the harmonized document was distributed in June of 2012. The United States submitted comments on the 3 CD in September 2012 and participated in a meeting of the Joint Working Group of these three organizations in London in October 2012. The American Water Works Association Committee on Water Meters is assisting in these efforts. The DR of R 49 passed its CIML preliminary ballot in May 2013, and R 49 is expected to receive final approval by the CIML in October 2013. Please contact Mr. Ralph Richter at (301) 975-3997 or ralph.richter@nist.gov, if you would like copies of documents or to participate in this project.

TC 8/SC 6 Measurement of Cryogenic Liquids (United States)

The Secretariat for R 81, *Dynamic Measuring Devices and Systems for Cryogenic Liquids* is working to complete project 1 to update: (1) electronic tests in accordance with the latest edition of OIML D 11 and/or the latest IEC and ISO standards; (2) technical requirements to include new developments in hydrogen measurements; and (3) current recommendations for density equations. OIML R 81 (1998) will be reformatted into two distinct parts in the format that is recommended for OIML Recommendations. The Secretariat asked members of TC 8/SC 6 and the USNWG to review and formally comment on the first committee draft of revised R 81, Part 1: Metrological and technical requirements and Part 2: Metrological controls and performance tests in May 2013. To obtain more information or to participate in this project, please contact Ms. Juana Williams at (301) 975-3989 or juana.williams@nist.gov.

TC 8/SC 7 Gas Metering (Netherlands)

OIML R 137-1 and R 137-2, *Gas Meters; Part 1: Metrological and Technical Requirements and Part 2: Metrological Controls and Performance Tests* were published in May 2012. Extensive United States comments on the 1 CD, the 2 CD, and the DR were developed in cooperation with the measurement committees of the American Gas Association. The OIML R 137 document is especially important to the U.S. interests because the American National Standards Institute (ANSI) B 109 committee on gas measurement is using the published R 137 to create a new performance-based standard for gas meters in the United States. Meetings of the working group that is developing this new standard ANSI B 109.0 were held in Charleston, South Carolina, in January 2013 and in Plano, Texas, in March 2013. Please contact Mr. Ralph Richter at (301) 975-3997 or ralph.richter@nist.gov, if you would like to participate in these efforts or if you would like to obtain a copy of any of these gas measurement documents.

The Project Group that is developing OIML R 139, *Compressed gaseous fuel measuring systems for vehicles*, distributed the 1 CD of the revised R 139 in May 2012. This standard is important to U.S. stakeholders, especially in the effort to maximize harmonization between domestic and international legal metrology requirements used for the delivery of alternative fuels such as hydrogen gas and compressed natural gas (CNG). The United States submitted comments on the 1 CD in August 2012, and participated in a Project Group meeting in November 2012 in Delft, The Netherlands. The United States voted “yes” with comments on the 2 CD of R 139 in April 2013. To obtain more information or to participate in this project, please contact Ms. Juana Williams at (301) 975-3989 or juana.williams@nist.gov.

TC 9 Instruments for Measuring Mass (United States)

The CIML approved a work item to revise OIML R 60:2000, *Metrological Regulation for Load Cells*. This revision is planned to cover everything from the basic principles of R 60 (e.g., tolerances and accuracy classes) to exploring the addition of new requirements. The United States distributed a 1st Committee Draft of R 60 Parts 1 and 2 (Metrological and technical requirements and Metrological controls and performance tests) to TC 9 members in August 2012. Comments on the 1 CD were due in November 2012 and were incorporated into a 2 CD. The 2 CD

was circulated in June 2013. For more information on these efforts, please contact Mr. John Barton at (301) 975-4002 or john.barton@nist.gov.

TC 9/SC 2 Automatic Weighing Instruments (United Kingdom)

The DR of OIML R 106, Part 1, *Automatic Rail Weighbridges*, was approved by a direct CIML online vote in April 2011, and R 106-1 was published in February 2012. The DR of R 106-2 was approved by the CIML in May 2012 and is awaiting publication by the BIML. To receive copies of these documents or to obtain more information on the work of this subcommittee, please contact Mr. John Barton at (301) 975-4002 or john.barton@nist.gov.

The Secretariat is in the process of revising OIML R 50, *Continuous Totalizing Automatic Weighing Instruments (Belt Weighers)*. The United States submitted comments on the 5 CD, Parts 1 and 2, of this Recommendation in October 2012. The Secretariat is now developing a DR of R 50-1 and R 50-2 for submission to the BIML as a CIML preliminary ballot. Comments have been returned on Part 3 of this Recommendation, and the Secretariat distributed the 2 CD of Part 3 in July 2013. For more information on this effort, please contact Mr. John Barton at (301) 975-4002 or john.barton@nist.gov.

TC 17/SC 1 Humidity (China and United States)

The Co Secretariats are working with a small International Project Group to revise OIML R 59, *Moisture Meters for Cereal Grains and Oilseeds*. All drafts have been distributed to the USNWG, which for the most part is a subset of the National Type Evaluation Program Grain Analyzer Sector. A preliminary 6 CD was developed based on international comments received on the 5 CD, and a meeting of TC 17/SC 1 was held in Orlando, Florida, to address those comments. Per discussions during that meeting, Germany submitted suggestions for additional software requirements that were included in the 6 CD. The 6 CD was distributed in March 2013 with comments returned in June 2013. Meetings of TC 17/SC 1 and TC 17/SC 8 will be held at NIST in Gaithersburg, July 23 - 25, 2013. Please contact Ms. G. Diane Lee at (301) 975-4405 or diane.lee@nist.gov if you would like to participate in this IWG.

TC 17/SC 8 Quality Analysis of Agricultural Products (Australia)

This subcommittee was formed to study the issues and write a working draft document *Measuring Instruments for Protein Determination in Grains*. Australia is the Secretariat. At a TC 17/SC 8 meeting hosted by NIST, the subcommittee discussed comments concerning the maximum permissible errors and harmonization of the TC 17/SC 8 Recommendation for protein with the TC 17/SC 1 Recommendation for moisture. International comments on the 2 CD were received and compiled. These comments were discussed at a meeting of TC 17/SC 8 in Orlando, Florida. The Secretariat completed the 3 CD based on the meeting discussion in Orlando. The United States submitted comments on the 3 CD in October 2012. Meetings of TC 17/SC 1 and TC 17/SC 8 was held at NIST in Gaithersburg, July 23 - 25, 2013. Please contact Ms. G. Diane Lee at (301) 975-4405 or diane.lee@nist.gov, if you would like to participate in this IWG.

OIML Mutual Acceptance Arrangement (MAA)

The report on the OIML MAA can be found in the NTEP section of this document. For further information on the MAA and its implementation, please contact Dr. Charles Ehrlich at (301) 975-4834 or e-mail charles.ehrlich@nist.gov.

II. REPORT ON THE 47TH CIML MEETING IN BUCHAREST, ROMANIA IN OCTOBER 2012

Mr. Peter Mason, CIML member from the United Kingdom and President of the CIML, opened the meeting and gave the President's Report.

Mr. Stephen Patoray, who has been serving as BIML Director since January 2011, provided several reports on financial and administrative matters at the BIML, including improvements that have been implemented since his arrival at the BIML. After consideration of an external auditor's review of the 2011 OIML accounts, the CIML approved the 2011 accounts, and instructed its President to present them to the 14th OIML Conference.

Mr. Patoray announced that there are seven new OIML Corresponding Members (all from Africa): Gambia, Liberia, Malawi, Mauritania, Namibia, Nigeria, and Sierra Leone. He also announced that Colombia would soon become an OIML Member State.

Dr. Grahame Harvey (Australia), currently serving as CIML 1st Vice President, announced that he was stepping down as the CIML Member from Australia due to financial considerations in Australia. Because of this, he also announced that he would not be running for reelection as CIML 1st Vice President. Discussions during the course of the CIML meeting eventually led to the appointment of the CIML 2nd Vice President (Roman Schwartz of PTB in Germany) to the position of 1st Vice President, with the decision to leave the position of 2nd Vice President unfilled until a new election could be held at the 2013 CIML meeting.

It was decided that the OIML Translation Center already has enough money to cover paying for a backlog of English to French translations of OIML publications, and that in the future such translations should be paid out of a regular budget line item. No formal action was taken on this item.

The CIML adopted 25 Resolutions in Bucharest, Romania. The most noteworthy resolutions included:

- the proposed 2013-2016 budget was agreed to be forwarded to the OIML Conference (including a line item for indirect support to developing countries, in areas such as training videos);
- the draft revision of the OIML Financial regulations were adopted (with minor amendments);
- Corresponding Members may now participate as Observing Members on OIML Technical Committees, Subcommittees, and Project Groups (without having to pay a fee);
- the revision of OIML B 6 *Directives for the Technical Work* was approved (subject to any necessary editorial changes that the United States submitted);
- the extension of the OIML Mutual Acceptance Arrangement to include test data from manufacturer's test labs (MTLs) on a voluntary basis was approved; and
- the NIST wording pertaining to a Resolution on the New SI was accepted.

The CIML approved the following Draft Publications in Bucharest, Romania:

- Revision of OIML D 1 Considerations for a law on metrology,
- Revision of OIML R 46 Electrical energy meters - Part 1: Metrological and technical requirements and Part 2: Metrological controls and performance tests,
- Revision of OIML R 106-2 Automatic rail weighbridges - Part 2: Test report format.

The CIML granted a special approval to OIML R 126, *Evidential breath analyzers*. Previously, in the preliminary ballot stage of R 126, the DR received five negative votes, some of which contained objections requiring substantial changes to the draft. Because the Secretariat of TC 17/SC 7 did not see any possibility to prepare a further draft that would remove the objections expressed in the preliminary ballot and because it was agreed that the revised text is a substantial improvement over the old version of OIML R 126 – the CIML decided to approve R 126 and then immediately start a revision process on the Recommendation.

III. REPORT ON THE 14TH OIML CONFERENCE IN BUCHAREST, ROMANIA, IN OCTOBER 2012

The OIML Conference adopted 16 Resolutions in Bucharest, many of which had to do with formalizing the adoption of Resolutions from the CIML Meeting on budgetary, policy, and administrative matters.

The audited accounts for 2008 - 2011 were approved, and it was decided that the budget surpluses (net results) from the 2009 - 2012 financial period were to be kept in reserve. The proposed budget for the calendar years 2013 - 2016 was also approved.

The following OIML Recommendations and Documents, approved by the CIML between 2009 and 2012, were officially sanctioned by the Conference:

- D 1:2012 Considerations for a law on metrology;
- D 16:2011 Principles of assurance of metrological control;
- R 35-2:2011 Material measures of length for general use. Part 2: Test methods;
- R 35-3:2011 Material measures of length for general use. Part 3: Test report format;
- R 46-1 and R 46-2:2012 Active electrical energy meters;
- R 80-1:2009 Road and rail tankers with level gauging. Part 1: Metrological and technical requirements;
- R 106-1:2011 Automatic rail-weighbridges. Part 1: Metrological and technical requirements – Tests;
- R 106-2:2012 Automatic rail-weighbridges. Part 2: Test report format;
- R 120:2010 Standard capacity measures for testing measuring systems for liquids other than water;
- R 126:2012 Evidential breath analyzers;
- R 134-2:2009 Automatic instruments for weighing road vehicles in motion and measuring axle loads. Part 2: Test report format;
- R 137-1&2:2012 Gas meters. Part 1: Metrological and technical requirements and Part 2 Metrological controls and performance tests;
- Am R 138:2009 – Amendment to R 138:2007 *Vessels for commercial transactions*;
- R 143:2009 Instruments for the continuous measurement of SO₂ in stationary source emissions;

The Conference also sanctioned the OIML Strategy as documented in OIML B 15:2011. The Conference instructed the CIML to implement this strategy while taking into account the budgetary resources.

IV. FUTURE OIML MEETINGS

The CIML accepted the invitation of Vietnam to host the 48th CIML Meeting next year in Ho Chi Minh City during the week of October 7 - 11, 2013.

The next OIML Conference will be held in 2016; the venue and dates for this Conference will be decided by the CIML at a future date.

V. REGIONAL LEGAL METROLOGY ORGANIZATIONS

Meeting of the Inter-American Metrology System (SIM) General Assembly and the SIM Legal Metrology Work Group (LMWG)

The SIM General Assembly (GA) was held in San Jose, Costa Rica, in November 2012. Mr. Jose Dajes Castro, from INDECOPI in Lima, Peru, serves as the SIM President. Mr. Marcos Senna at mjsenna@inmetro.gov.br, of INMETRO in Brazil, recently announced his resignation as the Chairman of the SIM LMWG. A new Chairman is

being sought. The organization is working to build capacity in legal metrology for SIM member countries. Please contact Mr. Ralph Richter at (301) 975-3997 or ralph.richter@nist.gov for more information on SIM.

Asia-Pacific Legal Metrology Forum (APLMF)

The 19th Meeting of APLMF was held November 5-9, 2012, in Cebu, The Philippines. Sixteen APLMF Member Economies participated in this meeting. The People’s Republic of China holds the Presidency and Secretariat of APLMF. Mr. Changcheng, APLMF President and Vice Minister of AQSIQ, chaired the meeting. APLMF activities are facilitated through its seven work groups. The most active is the work group on Training Coordination chaired by Australia.

The main objectives of APLMF are to coordinate regional training courses in legal metrology and to provide a forum for exchange of information among legal metrology authorities. The APLMF Secretariat spent a considerable amount of time, with the assistance of the United States, developing a proposal to obtain support from the Asia-Pacific Economic Cooperation (APEC) – Trade and Investment Liberalization and Facilitation funding in order to support the delivery of the training in 2012. Changes in APEC priorities are making it more difficult to achieve funding. While feedback from the previously-held training courses has been positive, it is becoming clear that in order to continue to receive funding for the training, APLMF needs to do a more thorough job of assessing and documenting the impact of the training courses on the economies that receive the training.

Discussions in Cebu included a review of the events and training courses held since the last APLMF meeting; these included:

- An APLMF-APMP Joint Symposium on “Metrology for Economic and Social Sustainability” (Beijing);
- An APLMF Training Course on “Traceability in Rice Moisture Measurement” (Indonesia, ‘self-funded’);
- A Training Course on “Verification of Non-automatic Weighing Instruments (Papua New Guinea);
- A Workshop on Technical Regulation and Harmonization of Bulk Fuel Trade Transactions in the APEC Region, Part 1 – “Improving the Custody Transfer of Liquid Fuel in the Asia-Pacific Region” (Singapore) (Ralph Richter of the NIST Office of Weights and Measures was the trainer); and
- A Workshop on Technical Regulation and Harmonization of Bulk Fuel Trade Transactions in the APEC Region, Part 2 – “Verification of bulk fuel using volumetric methods” (Thailand).

The United States was represented at the meeting in Cebu by Dr. Charles Ehrlich, who serves as Chairman of the APLMF work group on Mutual Recognition Arrangements. Dr. Ehrlich gave an extensive report and with updates on the OIML MAA and presented the United States Country Report. The 2013 APLMF meeting will be held in Yogyakarta, Indonesia, November 5 - 8, 2013.

THIS PAGE INTENTIONALLY LEFT BLANK

Appendix B

Associate Membership Committee (AMC) Agenda and Draft Meeting Minutes

Robert Murnane, Chair
Associate Membership Committee

Table A Table of Contents

Title of Content	BOD – B Page
AGENDA	1
AMC DRAFT MEETING MINUTES	2
Call to Order	2
Meeting Minutes.....	2
Financial Condition	2
Board of Directors Report.....	2
Professional Development Committee (PDC) Report	3
Laws and Regulations (L&R) Committee Report.....	3
AMC Fund Disbursement Report.....	3
Filling Vacant Positions.....	3
Old Business	3
New Business	4
Adjournment.....	5
Individuals in Attendance	5

Details of All Items (In order by Reference Key)

AGENDA

- I. Call to Order
- II. Approval of Meeting Minutes
- III. Financial Condition
- IV. NCWM Industry Representative Reports
 - (a) Board of Directors Report
 - (b) Professional Development Committee Report
 - (c) Laws and Regulations Committee Report
- V. AMC Fund Disbursement Requests
- VI. Filling Vacant Positions
- VII. Old Business
- VIII. New Business
- IX. Adjournment

AMC Draft Meeting Minutes

July 16, 2013
Louisville, KY

Call to Order

Chairman Robert Murnane called the meeting to order at 5:00 p.m.

Meeting Minutes

A copy of the 2013 Interim Meeting Minutes was distributed. These minutes were reviewed and a motion was made by Mr. Flocken and seconded by Mr. Johnson to approve the minutes as written. With no further discussion, the minutes were approved.

Financial Condition

A copy of the financial report was distributed; Chairman Murnane reported that the AMC fund has a balance of \$26,602.49. Ms. Jucoch questioned what the plans are for the current balance. Chairman Murnane explained the process for scholarships, and how the money is approved through the online form for requests for training. There were also questions regarding where the money comes from to support the balance. Chairman Murnane reports that \$15 from each membership is deposited in the AMC account.

Mr. Flocken stated that the annual dues are expected to increase the balance. Mr. Lewis reports one of the benefits of being a member is you get discount on NTEP certification fees. Chairman Murnane reported that there are discounts for testing as well.

Mr. Johnson reports there are currently 2156 members in the Conference; 803 associate members depending on the issue.

The financial report was reviewed and a motion was made by Mr. Johnson and seconded by Mr. Flocken to approve the financial report as written.

Board of Directors Report

Mr. Johnson, AMC representative on NCWM Board of Directors, gave a report regarding Board activities:

Mr. Johnson reports that the Conference has lost some very experienced weights and measures officials.

Terrence McBride had to resign from the BOD due to budget/travel issues with his program, and Clark Cooney of Oregon retired.

The SWMA Meeting will be in Charleston, West Virginia, October 7 - 9, 2013, and the Measuring Sector Meeting will meet after the SWMA Meeting.

AMC – Nothing new other than they are waiting for a response to a request for any kind of assistance on the new tool kit – whether funds or other support.

Several states and NIST are requesting help with travel expenses for training. The states and NIST can provide the training, but lack of travel funds is limiting attendance at these important training programs.

NIST – Package Inspection Training, help is needed in funding the purchase of materials (groceries) for these classes.

NIST/WMD – Ms. Carol Hockert reported that Mr. Marc Butler resigned. She is looking to fill this position as soon as possible.

Work GROUP Updates – The Taximeters Work Group is looking for a statement from NIST regarding the use of alternative devices. A newsletter article may help address what tools the states have when looking at devices that are not covered in NIST Handbook 44 or NTEB approved.

NCWM Treasurers Report – The NCWM is in good financial shape.

Activity Reports – Current membership is 2156.

Annual and Interim Meetings – 2015 Planning for the 100th meeting is in process – Need AMC input. Chairmen Murnane ask that we discuss under new business

Toolkit Work Group – NCWM Chair, Mr. Steve Benjamin met with the NEWMA and CWMA. First priorities for these groups are for a video and templates (CWMA). Mr. Benjamin will meet with the SWMA and WWMA this week. A task group will meet Sunday afternoon.

NTEP Staffing – NCWM advertised a new position for additional NTEP personnel. There is a lot of interest and candidates.

Professional Development Committee (PDC) Report

Mr. Steve Grabski mentioned that getting the trainers out traveling will be a big help. Chairman Murnane mentions that he appreciates the work that the PDC has completed. Pretty much everyone present at the Conference for business has a course that pertains to him or her.

Laws and Regulations (L&R) Committee Report

Mr. Grabski will be move to the L&R Committee from PDC; No updates for the L&R Committee.

AMC Fund Disbursement Report

Chairmen Murnane reports the Washington request was paid, and the California request is still pending. California's training will take place in August.

Filling Vacant Positions

Mr. Paul Lewis agreed to fill the Associate Chair.

Mr. Bill Callaway agreed to fill Vice Chair.

Mr. David Calix agreed to fill Secretary Treasure.

Associate Committee Member - Darrel Flocken – will stay on as a committee member.

Associate Committee Member - Chairman Murnane – will stay on as a committee member.

Old Business

Mr. Gurney reports there is a request for training for the Northern Mariana Islands a U.S. territory; they are looking for training on package inspections. Mr. Don Onwiler and NIST put their heads together on who could do this training and decided on Mr. Gurney. The Northern Mariana Islands will be putting a request together for approximately \$4300; they want the AMC to think it over.

Chairmen Murnane asked, “Does NIST have an online course for the training? Are the Northern Mariana Islands members of the Conference? Could the training be completed through a webinar or WebEx?” Chairmen Murnane

asks that they check into online training and then apply online. Mr. Gurney stated originally there were going to be approximately 25 people needing training, and then there were some issues with getting all the folks to the training. Mr. Flocken stated that the more information that can be provided in the application the better and it can be look at as a cost vs. value. Mr. Lewis states that they should make sure they request enough funds; AMC will not approve extra funds. Chairmen Murnane ask that Mr. Gurney get the information regarding WebEx, Webinar, NIST and online training, put in the application and the Committee will vote on it.

Mr. Oppermann believes that it is a worthwhile request. Chairmen Murnane asked if NIST is available for the training.

Mr. Onwiler reports that the Northern Mariana Islands does not have a NCWM membership at this time. Mr. Onwiler stated that NCWM does have a WebEx account that he uses to host meetings for NCWM groups. Chairmen Murnane reported that there may be an issue if they are not members, and Mr. Lewis stated not all the inspectors that are trained with AMC funds are members.

Mr. Gurney will get the information for the requested training and put in a request for funds when all details become available.

New Business

Chairman Murnane stated that Ms. Julie Quinn (Minnesota) is requesting money to send people on travel. Mr. Floken stated that we will pay for travel for trainers, but not for travel for people to get training.

Chairmen Murnane states that it's difficult to control. You don't know what the benefits are and what we will get out of it. We will pay for trainers to travel and facilities but not for trainees to get training.

Chairmen Murnane stated we will buy the items for packing checking and tools.

Chairmen Murnane asked, "Is there something that the AMC wants to do for the NCWM's 100th Meeting?" Mr. Lewis asked, "Do we want to make a pin or a paper weight?"

Mr. Flocken stated that the SMA was looking into sponsoring a lunch but we cannot do that. The Conference will not accept sponsorship.

Mr. Flocken stated he would rather spend the money on training as it's designed.

Mr. Onwiler reported that the Conference will not accept any sponsorship, the policy is very clear, if a group wants to go off and do something on their own, NCWM cannot endorse it and that activity would violate a gentlemen's agreement against hospitality suites. The work group is asking to suspend the rules for one event. The decision has not been made.

Chairmen Murnane stated he would like for the policy to stand, if the news media were to get ahold of it and spin it the wrong way it would look very bad for the Conference.

Mr. Onwiler stated NIST put together the very first handbook standards adopted by NCWM as a gift to the attendees of NCWM's 100-Year Anniversary Event.

Is there a difference between providing food and beverage vs. providing a gift? Mr. Onwiler does not know if that would be allowed, but that's still sponsorship, and it's a board decision. Mr. Onwiler encourages that we voice comments to the Board regarding sponsorship.

Mr. Lewis states members are welcome to set up their own booth and give away items. Mr. Onwiler stated that NCWM is not sponsoring it.

Mr. Onwiler wants the 100th to be a success.

Chairmen Murnane does not want to relax the rules, and we want to stay above reproach at all times. We don't want companies to have hospitality suites serving shrimp cocktails all night that's negative for the Conference.

Mr. Flocken stated that he supports what Chairmen Murnane says. Mr. Flocken stated giving away a gift or pin is not money well spent. We need to save the money for training opportunities.

Ms. Hemida asked, "Can we call suppliers and put on training for the Conference?" Chairmen Murnane stated that the training would be more beneficial at the regional level. Most of the folks attending the National meeting are not the ones needing training.

Ms. Hemida asks why not come up with something about the history of weights and measures past 100 years of events. How did we get to where we are now – a video or a DVD of five to seven minutes of the history?

Chairmen Murnane asked how about weights and measure history as a video, understanding the history of weights and measures.

Mr. Oppermann reported that Mr. Onwiler told him the estimated cost is \$1000/min. We would not need a very lengthy video.

Ms. Juroch asked if the Smithsonian has anything on the history of scales.

You have to touch everything, scales, gas pumps, all parts of weights and measures.

Chairmen Murnane and the group liked the DVD idea; Ms. Hemida will get with Mr. Onwiler and let us know on the feedback.

Adjournment

Mr. Oppermann said thank you Chairmen Murnane for his effort and his contribution.

Mr. Lewis moved to adjourn the meeting, a motion was made, and the meeting was adjourned at 5:58 p.m.

Respectfully submitted by,
Mr. David Calix
Secretary, AMC

Individuals in Attendance

Mr. David Calix – NCR
Mr. Paul Lewis – Rice Lake
Mr. Gordon Johnson – Gilbarco
Ms. Zina Juroch – Pier 1 Imports
Mr. Henry Oppermann – W+M Consulting
Mr. Darrell Flocken – Mettler-Toledo LLC
Mr. Louis Straub – Fairbanks Scales
Mr. Rob Upright – Vishay Transducers
Mr. Steven Grabski – Walmart Stores
Ms. Maile Hemida – Hogan Lovell’s USUP
Mr. Adam Bolain – HJ Heinz
Mr. Russ Lewis – Marathon Petroleum
Mr. Curt Williams – CP Williams Energy Consulting
Mr. John Hughes – Rice Lake Weighing Systems
Mr. Pete O’Bryan – Foster Farms
Mr. Bill Callaway – Crompco
Mr. Bob Murnane – Seraphin

Appendix A

Report of the Activities of the International Organization of Legal Metrology (OIML) and Regional Legal Metrology Organizations

National Institute of Standards and Technology (NIST), Office of Weights and Measures (OWM)

INTRODUCTION

The NIST, OWM is responsible for coordinating United States participation in OIML and other international legal metrology organizations. Learn more about OIML at www.oiml.org and about NIST, OWM at www.nist.gov/owm. Dr. Charles Ehrlich, Program Leader of the International Legal Metrology Program, can be contacted at (301) 975-4834 by fax at (301) 975-8091 or charles.ehrlich@nist.gov.

Note: OIML publications are available without cost at www.oiml.org.

Table A
Table of Contents

Title of Content	BOD – A Page
INTRODUCTION	1
I. REPORT ON THE ACTIVITIES OF THE OIML TECHNICAL COMMITTEES	3
TC 3/SC 5 Conformity Assessment (United States)	3
TC 5/SC 1 Environmental Conditions (Netherlands)	3
TC 5/SC 2 Software (Germany and BIML)	3
TC 6 Prepackaged Products (South Africa)	3
TC 8 Measurement of Quantities of Fluids (Japan)	4
TC 8/SC 1 Static Volume and Mass Measurement (Germany)	4
TC 8/SC 3 Dynamic Volume and Mass Measurement for Liquids Other Than Water (United States and Germany)	4
TC 8/SC 5 Water Meters (United Kingdom)	5
TC 8/SC 6 Measurement of Cryogenic Liquids (United States)	5
TC 8/SC 7 Gas Metering (Netherlands)	5
TC 17/SC 8 Quality Analysis of Agricultural Products (Australia)	6
OIML Mutual Acceptance Arrangement (MAA)	6
II. REPORT ON THE 47TH CIML MEETING IN BUCHAREST, ROMANIA IN OCTOBER 2012.....	6
III. REPORT ON THE 14TH OIML CONFERENCE IN BUCHAREST, ROMANIA, IN OCTOBER 2012	7
IV. FUTURE OIML MEETINGS	8
V. REGIONAL LEGAL METROLOGY ORGANIZATIONS.....	8

Table B
Glossary of Acronyms and Terms

Acronym	Term	Acronym	Term
ANSI	American National Standards Institute	ISO	International Standardization Organization
APEC	Asia-Pacific Economic Cooperation	IWG	International Work Group
APLMF	Asia-Pacific Legal Metrology Forum	LMWG	Legal Metrology Work Group
APMP	Asia-Pacific Metrology Program	MAA	Mutual Acceptance Agreement
B	Basic Publication	MTL	Manufacturers' Testing Laboratory
BIML	International Bureau of Legal Metrology	NIST	National Institute of Standards and Technology
BIPM	International Bureau of Weights and Measures	NTEP	National Type Evaluation Program
CD	Committee Draft ¹	OIML	International Organization of Legal Metrology
CIML	International Committee of Legal Metrology	OWM	Office of Weights and Measures
CTT	Conformity to Type	PG	Project Group
D	Document	R	Recommendation
DD	Draft Document ²	SC	Technical Subcommittee
DoMC	Declaration of Mutual Confidence	SIM	Inter-American Metrology System
DR	Draft Recommendation ²	TC	Technical Committee
DV	Draft Vocabulary ³	USNWG	U.S. National Work Group
GA	General Assembly	VIM	International Vocabulary of Metrology
IEC	International Electrotechnical Commission	VIML	International Vocabulary of Legal Metrology
IQ Mark	International Quantity Mark	WD	Working Draft ³
<p>¹ CD: a draft at the stage of development within a technical committee or subcommittee; in this document, successive drafts are numbered 1 CD, 2 CD, etc.</p> <p>² DD, DR, and DV: a draft document approved at the level of the technical committee or subcommittee concerned and sent to BIML for approval by CIML</p> <p>³WD: precedes the development of a CD; in this document, successive drafts are number 1 WD, 2 WD, etc.</p>			

Details of All Items
(In order by Reference Key)

I. REPORT ON THE ACTIVITIES OF THE OIML TECHNICAL COMMITTEES

This section reports on recent activities and the status of work in the OIML Technical Committees (TCs), Technical Subcommittees (SCs), and Project Groups (PGs) of specific interest to members of the National Conference on Weights and Measures (NCWM). Schedules of future activities of the TC/SC Secretariats, PG Convenors, the U.S. National Work Groups (USNWGs), and the International Work Groups (IWGs) and Project Groups of the TCs and SCs are also included.

TC 3/SC 5 Conformity Assessment (United States)

The OIML Basic Publications B 3 *Certificate System* and B 10 *Mutual Acceptance Arrangement (MAA)* were recently revised to incorporate updated practices, and to provide full consistency (including terminology) between the two documents. At the International Committee of Legal Metrology (CIML) Meeting in Bucharest, Romania, in October 2012 an Amendment to B 10 was approved that allows for the voluntary use of test data from manufacturer's test laboratories (MTLs) under specially supervised conditions. A Workshop is planned for the 2013 CIML Meeting (in Vietnam) to gather experiences of the various users and other stakeholders in the MAA. The 2nd Committee Draft (2 CD) of a new OIML document entitled *The Role of Measurement Uncertainty in Conformity Assessment Decisions in Legal Metrology* is under development by the Secretariat. Please see the MAA section in the National Type Evaluation Program (NTEP) Committee Report of this publication for more details on the activities of TC 3/SC 5. For more information on the activities of this subcommittee, please contact Dr. Charles Ehrlich at (301) 975-4834 or charles.ehrlich@nist.gov.

TC 5/SC 1 Environmental Conditions (Netherlands)

The Secretariat distributed the 2 CD revision of OIML Document D 11 *General requirements for measuring instruments - Environmental conditions*, in January 2012. This is a very important document in the OIML system and is used by all of the OIML TCs as a general reference for technical and testing requirements on all measuring instruments. The United States submitted comments on the 2 CD in March 2012. Before distribution of the 2 CD, the United States participated in a meeting of TC 5/SC 1 to discuss the D 11 document in Utrecht, The Netherlands. Highlights of the discussions in Utrecht included: expanding the terminology section, updating several testing sections to reflect the latest International Electrotechnical Commission (IEC) reference standards, and including a new environmental class ("E3") for a non-mains local source of electrical power supply. The OIML Expert Report E 5 *Overview of the Present Status of the Standards Referred to in OIML D 11 – General Requirements for Electronic Measuring Instruments* was recently published and updates all of the IEC references for testing requirements in D 11. The DD of D 11 passed its CIML preliminary ballot in December 2012. It is expected that this new revision of D 11 will be approved by the CIML and be published later in 2013. Please contact Mr. Ralph Richter at (301) 975-3997 or ralph.richter@nist.gov, if you would like further information on this project.

TC 5/SC 2 Software (Germany and BIML)

The OIML D 31 *General Requirements for Software-controlled Measuring Instruments* has been published and will serve as guidance for software requirements in International Recommendations by OIML TCs. The United States participated in the technical work on this document and submitted votes and comments on several drafts of the document. A new project on software verification was approved by CIML, and the United States is waiting for the first draft of this document. Please contact Dr. Ambler Thompson at (301) 975-2333 or ambler@nist.gov if you would like to discuss OIML software efforts.

TC 6 Prepackaged Products (South Africa)

After an online CIML vote was conducted, it was decided that the TC 6 project to develop an OIML International Quantity Mark (IQ Mark) would be terminated. The United States had already voted in favor of terminating this

project on the grounds that the effort to manage and certify quality control systems would have added unnecessary extra costs, with no value added, to all participating suppliers. At the same time, another CIML vote (same deadline) was conducted on a proposal for a new TC 6 project *Guidance for defining the system requirements for a certification system for prepackages*. The United States voted against this proposal on the grounds that even such an OIML Guidance Document could be construed as endorsing an OIML IQ Mark program. The results of the CIML vote on this proposal, and the best way forward are still being decided.

A meeting of TC 6 was held in Tokyo, Japan, in October 2012. Besides the IQ Mark project, two other important projects were heavily discussed: a revision of OIML Recommendation (R) 87 *Quantity of Product in Prepackages* (the OIML equivalent to NIST Handbook 133, *Checking the Net Contents of Packaged Goods*) and a revision of OIML R 79 *Labeling Requirements for Prepackaged Products*. The NIST Statistical Engineering Division (SED) has been participating in a small ad-hoc work group to improve the statistics in R 87. A 1st Committee Draft of R 87 has been developed and circulated for comment by the Secretariat. Also, the Secretariat has developed and circulated for comment a 3rd Committee Draft of R 79. The comment period for both of these CDs ended in March 2013. Both drafts contain proposed revisions that NIST OWM believes are unnecessarily complex, and, therefore, subject to easy misinterpretation, and another that appeared to go beyond the scope of package labeling requirements. After consulting with the Chairman of the NCWM Packaging and Labeling Subcommittee about the proposed revisions to both R 87 and R 79, the United States voted “no” on R 79 (votes are not taken on 1st Committee Drafts, so only comments were submitted on R 87). The main reason for opposing both drafts is that they include proposed definitions for prepackage, packaging material, and product that are likely to result in confusion for consumers and packers alike.

For more information on the activities of this subcommittee, and to participate in the U.S. review of these CDs, please contact Mr. Ken Butcher at (301) 975-4859 or kbutcher@nist.gov.

TC 8 Measurement of Quantities of Fluids (Japan)

The CIML has approved projects to revise the following TC 8 documents: R 63 *Petroleum Measurement Tables* (1994) and R 119 *Pipe Provers for Testing of Measuring Systems for Liquids Other Than Water* (1996). Both of these documents are important for other OIML recommendations involving liquid measurement. Please contact Mr. Ralph Richter at (301) 975-3997 or ralph.richter@nist.gov, if you would like copies of the documents or to participate in any of these projects.

TC 8/SC 1 Static Volume and Mass Measurement (Germany)

The United States chairs the Project Group that is drafting new sections of OIML R 71, *Fixed Storage Tanks* and R 85, *Automatic Level Gages for Measuring the Level of Liquid in Fixed Storage Tanks* to add specific requirements for specialized tanks. OIML R 80-2, *Road and Rail Tankers, Test Methods*, is being developed by Germany. Please contact Mr. Ralph Richter at (301) 975-3997 or ralph.richter@nist.gov, if you would like to receive copies of the documents, or to participate in any of these projects.

TC 8/SC 3 Dynamic Volume and Mass Measurement for Liquids Other Than Water (United States and Germany)

Subcommittee work is continuing on the development of OIML R 117-2, *Dynamic Measuring Systems for Liquids Other Than Water, Part 2, Test Methods*, and R 117-3, *Test Report Format*. New annexes for measuring systems for foaming potable liquids, for pipelines, and for aircraft refueling are being developed. The Project Group for the development of R 117 also continues to hold international web-meetings to accelerate the work on this high priority document.

A meeting of the full TC 8/SC 3 subcommittee was hosted by the European Committee of Manufacturers of Petroleum Measuring Systems (CECOD) and the Syndicat de la Mesure at their Paris headquarters in November 2012. The subcommittee meeting was attended by 31 participants, including official representatives from 15 countries. Additionally, several representatives of major manufacturers of these systems and liaison organizations actively participated in the meeting. These technical experts provided a depth of experience and technical expertise that proved highly valuable during the meeting. The 2 CD of R 117-2 is planned to be

distributed in April 2013, and a meeting of the R 117 Project Group will be held October 1 - 3, 2013, in London, England. If you have any questions or would like to participate in the next phases of this project, please contact Mr. Ralph Richter at (301) 975-3997 or ralph.richter@nist.gov.

TC 8/SC 5 Water Meters (United Kingdom)

OIML, the International Standardization Organization (ISO), and the European Committee for Standardization (CEN) are working together to harmonize requirements for water meters using OIML R 49, *Water Meters Intended for the Metering of Cold Potable Water and Hot Water Parts 1, 2, and 3* as the base document. The 3 CD of the harmonized document was distributed in June of 2012. The United States submitted comments on the 3 CD in September 2012 and participated in a meeting of the Joint Working Group of these three organizations in London in October 2012. The American Water Works Association Committee on Water Meters is assisting in these efforts. The DR of R 49 passed its CIML preliminary ballot in May 2013, and R 49 is expected to receive final approval by the CIML in October 2013. Please contact Mr. Ralph Richter at (301) 975-3997 or ralph.richter@nist.gov, if you would like copies of documents or to participate in this project.

TC 8/SC 6 Measurement of Cryogenic Liquids (United States)

The Secretariat for R 81, *Dynamic Measuring Devices and Systems for Cryogenic Liquids* is working to complete project 1 to update: (1) electronic tests in accordance with the latest edition of OIML D 11 and/or the latest IEC and ISO standards; (2) technical requirements to include new developments in hydrogen measurements; and (3) current recommendations for density equations. OIML R 81 (1998) will be reformatted into two distinct parts in the format that is recommended for OIML Recommendations. The Secretariat asked members of TC 8/SC 6 and the USNWG to review and formally comment on the first committee draft of revised R 81, Part 1: Metrological and technical requirements and Part 2: Metrological controls and performance tests in May 2013. To obtain more information or to participate in this project, please contact Ms. Juana Williams at (301) 975-3989 or juana.williams@nist.gov.

TC 8/SC 7 Gas Metering (Netherlands)

OIML R 137-1 and R 137-2, *Gas Meters; Part 1: Metrological and Technical Requirements and Part 2: Metrological Controls and Performance Tests* were published in May 2012. Extensive United States comments on the 1 CD, the 2 CD, and the DR were developed in cooperation with the measurement committees of the American Gas Association. The OIML R 137 document is especially important to the U.S. interests because the American National Standards Institute (ANSI) B 109 committee on gas measurement is using the published R 137 to create a new performance-based standard for gas meters in the United States. Meetings of the working group that is developing this new standard ANSI B 109.0 were held in Charleston, South Carolina, in January 2013 and in Plano, Texas, in March 2013. Please contact Mr. Ralph Richter at (301) 975-3997 or ralph.richter@nist.gov, if you would like to participate in these efforts or if you would like to obtain a copy of any of these gas measurement documents.

The Project Group that is developing OIML R 139, *Compressed gaseous fuel measuring systems for vehicles*, distributed the 1 CD of the revised R 139 in May 2012. This standard is important to U.S. stakeholders, especially in the effort to maximize harmonization between domestic and international legal metrology requirements used for the delivery of alternative fuels such as hydrogen gas and compressed natural gas (CNG). The United States submitted comments on the 1 CD in August 2012, and participated in a Project Group meeting in November 2012 in Delft, The Netherlands. The United States voted “yes” with comments on the 2 CD of R 139 in April 2013. To obtain more information or to participate in this project, please contact Ms. Juana Williams at (301) 975-3989 or juana.williams@nist.gov.

TC 9 Instruments for Measuring Mass (United States)

The CIML approved a work item to revise OIML R 60:2000, *Metrological Regulation for Load Cells*. This revision is planned to cover everything from the basic principles of R 60 (e.g., tolerances and accuracy classes) to exploring the addition of new requirements. The United States distributed a 1st Committee Draft of R 60 Parts 1 and 2 (Metrological and technical requirements and Metrological controls and performance tests) to TC 9 members in August 2012. Comments on the 1 CD were due in November 2012 and were incorporated into a 2 CD. The 2 CD

was circulated in June 2013. For more information on these efforts, please contact Mr. John Barton at (301) 975-4002 or john.barton@nist.gov.

TC 9/SC 2 Automatic Weighing Instruments (United Kingdom)

The DR of OIML R 106, Part 1, *Automatic Rail Weighbridges*, was approved by a direct CIML online vote in April 2011, and R 106-1 was published in February 2012. The DR of R 106-2 was approved by the CIML in May 2012 and is awaiting publication by the BIML. To receive copies of these documents or to obtain more information on the work of this subcommittee, please contact Mr. John Barton at (301) 975-4002 or john.barton@nist.gov.

The Secretariat is in the process of revising OIML R 50, *Continuous Totalizing Automatic Weighing Instruments (Belt Weighers)*. The United States submitted comments on the 5 CD, Parts 1 and 2, of this Recommendation in October 2012. The Secretariat is now developing a DR of R 50-1 and R 50-2 for submission to the BIML as a CIML preliminary ballot. Comments have been returned on Part 3 of this Recommendation, and the Secretariat distributed the 2 CD of Part 3 in July 2013. For more information on this effort, please contact Mr. John Barton at (301) 975-4002 or john.barton@nist.gov.

TC 17/SC 1 Humidity (China and United States)

The Co Secretariats are working with a small International Project Group to revise OIML R 59, *Moisture Meters for Cereal Grains and Oilseeds*. All drafts have been distributed to the USNWG, which for the most part is a subset of the National Type Evaluation Program Grain Analyzer Sector. A preliminary 6 CD was developed based on international comments received on the 5 CD, and a meeting of TC 17/SC 1 was held in Orlando, Florida, to address those comments. Per discussions during that meeting, Germany submitted suggestions for additional software requirements that were included in the 6 CD. The 6 CD was distributed in March 2013 with comments returned in June 2013. Meetings of TC 17/SC 1 and TC 17/SC 8 will be held at NIST in Gaithersburg, July 23 - 25, 2013. Please contact Ms. G. Diane Lee at (301) 975-4405 or diane.lee@nist.gov if you would like to participate in this IWG.

TC 17/SC 8 Quality Analysis of Agricultural Products (Australia)

This subcommittee was formed to study the issues and write a working draft document *Measuring Instruments for Protein Determination in Grains*. Australia is the Secretariat. At a TC 17/SC 8 meeting hosted by NIST, the subcommittee discussed comments concerning the maximum permissible errors and harmonization of the TC 17/SC 8 Recommendation for protein with the TC 17/SC 1 Recommendation for moisture. International comments on the 2 CD were received and compiled. These comments were discussed at a meeting of TC 17/SC 8 in Orlando, Florida. The Secretariat completed the 3 CD based on the meeting discussion in Orlando. The United States submitted comments on the 3 CD in October 2012. Meetings of TC 17/SC 1 and TC 17/SC 8 was held at NIST in Gaithersburg, July 23 - 25, 2013. Please contact Ms. G. Diane Lee at (301) 975-4405 or diane.lee@nist.gov, if you would like to participate in this IWG.

OIML Mutual Acceptance Arrangement (MAA)

The report on the OIML MAA can be found in the NTEP section of this document. For further information on the MAA and its implementation, please contact Dr. Charles Ehrlich at (301) 975-4834 or e-mail charles.ehrlich@nist.gov.

II. REPORT ON THE 47TH CIML MEETING IN BUCHAREST, ROMANIA IN OCTOBER 2012

Mr. Peter Mason, CIML member from the United Kingdom and President of the CIML, opened the meeting and gave the President's Report.

Mr. Stephen Patoray, who has been serving as BIML Director since January 2011, provided several reports on financial and administrative matters at the BIML, including improvements that have been implemented since his arrival at the BIML. After consideration of an external auditor's review of the 2011 OIML accounts, the CIML approved the 2011 accounts, and instructed its President to present them to the 14th OIML Conference.

Mr. Patoray announced that there are seven new OIML Corresponding Members (all from Africa): Gambia, Liberia, Malawi, Mauritania, Namibia, Nigeria, and Sierra Leone. He also announced that Colombia would soon become an OIML Member State.

Dr. Grahame Harvey (Australia), currently serving as CIML 1st Vice President, announced that he was stepping down as the CIML Member from Australia due to financial considerations in Australia. Because of this, he also announced that he would not be running for reelection as CIML 1st Vice President. Discussions during the course of the CIML meeting eventually led to the appointment of the CIML 2nd Vice President (Roman Schwartz of PTB in Germany) to the position of 1st Vice President, with the decision to leave the position of 2nd Vice President unfilled until a new election could be held at the 2013 CIML meeting.

It was decided that the OIML Translation Center already has enough money to cover paying for a backlog of English to French translations of OIML publications, and that in the future such translations should be paid out of a regular budget line item. No formal action was taken on this item.

The CIML adopted 25 Resolutions in Bucharest, Romania. The most noteworthy resolutions included:

- the proposed 2013-2016 budget was agreed to be forwarded to the OIML Conference (including a line item for indirect support to developing countries, in areas such as training videos);
- the draft revision of the OIML Financial regulations were adopted (with minor amendments);
- Corresponding Members may now participate as Observing Members on OIML Technical Committees, Subcommittees, and Project Groups (without having to pay a fee);
- the revision of OIML B 6 *Directives for the Technical Work* was approved (subject to any necessary editorial changes that the United States submitted);
- the extension of the OIML Mutual Acceptance Arrangement to include test data from manufacturer's test labs (MTLs) on a voluntary basis was approved; and
- the NIST wording pertaining to a Resolution on the New SI was accepted.

The CIML approved the following Draft Publications in Bucharest, Romania:

- Revision of OIML D 1 Considerations for a law on metrology,
- Revision of OIML R 46 Electrical energy meters - Part 1: Metrological and technical requirements and Part 2: Metrological controls and performance tests,
- Revision of OIML R 106-2 Automatic rail weighbridges - Part 2: Test report format.

The CIML granted a special approval to OIML R 126, *Evidential breath analyzers*. Previously, in the preliminary ballot stage of R 126, the DR received five negative votes, some of which contained objections requiring substantial changes to the draft. Because the Secretariat of TC 17/SC 7 did not see any possibility to prepare a further draft that would remove the objections expressed in the preliminary ballot and because it was agreed that the revised text is a substantial improvement over the old version of OIML R 126 – the CIML decided to approve R 126 and then immediately start a revision process on the Recommendation.

III. REPORT ON THE 14TH OIML CONFERENCE IN BUCHAREST, ROMANIA, IN OCTOBER 2012

The OIML Conference adopted 16 Resolutions in Bucharest, many of which had to do with formalizing the adoption of Resolutions from the CIML Meeting on budgetary, policy, and administrative matters.

The audited accounts for 2008 - 2011 were approved, and it was decided that the budget surpluses (net results) from the 2009 - 2012 financial period were to be kept in reserve. The proposed budget for the calendar years 2013 - 2016 was also approved.

The following OIML Recommendations and Documents, approved by the CIML between 2009 and 2012, were officially sanctioned by the Conference:

- D 1:2012 Considerations for a law on metrology;
- D 16:2011 Principles of assurance of metrological control;
- R 35-2:2011 Material measures of length for general use. Part 2: Test methods;
- R 35-3:2011 Material measures of length for general use. Part 3: Test report format;
- R 46-1 and R 46-2:2012 Active electrical energy meters;
- R 80-1:2009 Road and rail tankers with level gauging. Part 1: Metrological and technical requirements;
- R 106-1:2011 Automatic rail-weighbridges. Part 1: Metrological and technical requirements – Tests;
- R 106-2:2012 Automatic rail-weighbridges. Part 2: Test report format;
- R 120:2010 Standard capacity measures for testing measuring systems for liquids other than water;
- R 126:2012 Evidential breath analyzers;
- R 134-2:2009 Automatic instruments for weighing road vehicles in motion and measuring axle loads. Part 2: Test report format;
- R 137-1&2:2012 Gas meters. Part 1: Metrological and technical requirements and Part 2 Metrological controls and performance tests;
- Am R 138:2009 – Amendment to R 138:2007 *Vessels for commercial transactions*;
- R 143:2009 Instruments for the continuous measurement of SO₂ in stationary source emissions;

The Conference also sanctioned the OIML Strategy as documented in OIML B 15:2011. The Conference instructed the CIML to implement this strategy while taking into account the budgetary resources.

IV. FUTURE OIML MEETINGS

The CIML accepted the invitation of Vietnam to host the 48th CIML Meeting next year in Ho Chi Minh City during the week of October 7 - 11, 2013.

The next OIML Conference will be held in 2016; the venue and dates for this Conference will be decided by the CIML at a future date.

V. REGIONAL LEGAL METROLOGY ORGANIZATIONS

Meeting of the Inter-American Metrology System (SIM) General Assembly and the SIM Legal Metrology Work Group (LMWG)

The SIM General Assembly (GA) was held in San Jose, Costa Rica, in November 2012. Mr. Jose Dajes Castro, from INDECOPI in Lima, Peru, serves as the SIM President. Mr. Marcos Senna at mjsenna@inmetro.gov.br, of INMETRO in Brazil, recently announced his resignation as the Chairman of the SIM LMWG. A new Chairman is

being sought. The organization is working to build capacity in legal metrology for SIM member countries. Please contact Mr. Ralph Richter at (301) 975-3997 or ralph.richter@nist.gov for more information on SIM.

Asia-Pacific Legal Metrology Forum (APLMF)

The 19th Meeting of APLMF was held November 5-9, 2012, in Cebu, The Philippines. Sixteen APLMF Member Economies participated in this meeting. The People's Republic of China holds the Presidency and Secretariat of APLMF. Mr. Changcheng, APLMF President and Vice Minister of AQSIQ, chaired the meeting. APLMF activities are facilitated through its seven work groups. The most active is the work group on Training Coordination chaired by Australia.

The main objectives of APLMF are to coordinate regional training courses in legal metrology and to provide a forum for exchange of information among legal metrology authorities. The APLMF Secretariat spent a considerable amount of time, with the assistance of the United States, developing a proposal to obtain support from the Asia-Pacific Economic Cooperation (APEC) – Trade and Investment Liberalization and Facilitation funding in order to support the delivery of the training in 2012. Changes in APEC priorities are making it more difficult to achieve funding. While feedback from the previously-held training courses has been positive, it is becoming clear that in order to continue to receive funding for the training, APLMF needs to do a more thorough job of assessing and documenting the impact of the training courses on the economies that receive the training.

Discussions in Cebu included a review of the events and training courses held since the last APLMF meeting; these included:

- An APLMF-APMP Joint Symposium on “Metrology for Economic and Social Sustainability” (Beijing);
- An APLMF Training Course on “Traceability in Rice Moisture Measurement” (Indonesia, ‘self-funded’);
- A Training Course on “Verification of Non-automatic Weighing Instruments (Papua New Guinea);
- A Workshop on Technical Regulation and Harmonization of Bulk Fuel Trade Transactions in the APEC Region, Part 1 – “Improving the Custody Transfer of Liquid Fuel in the Asia-Pacific Region” (Singapore) (Ralph Richter of the NIST Office of Weights and Measures was the trainer); and
- A Workshop on Technical Regulation and Harmonization of Bulk Fuel Trade Transactions in the APEC Region, Part 2 – “Verification of bulk fuel using volumetric methods” (Thailand).

The United States was represented at the meeting in Cebu by Dr. Charles Ehrlich, who serves as Chairman of the APLMF work group on Mutual Recognition Arrangements. Dr. Ehrlich gave an extensive report and with updates on the OIML MAA and presented the United States Country Report. The 2013 APLMF meeting will be held in Yogyakarta, Indonesia, November 5 - 8, 2013.

THIS PAGE INTENTIONALLY LEFT BLANK

Appendix B

Associate Membership Committee (AMC) Agenda and Draft Meeting Minutes

Robert Murnane, Chair
Associate Membership Committee

Table A Table of Contents

Title of Content	BOD – B Page
AGENDA	1
AMC DRAFT MEETING MINUTES	2
Call to Order	2
Meeting Minutes.....	2
Financial Condition	2
Board of Directors Report.....	2
Professional Development Committee (PDC) Report	3
Laws and Regulations (L&R) Committee Report.....	3
AMC Fund Disbursement Report.....	3
Filling Vacant Positions.....	3
Old Business	3
New Business	4
Adjournment.....	5
Individuals in Attendance	5

Details of All Items (In order by Reference Key)

AGENDA

- I. Call to Order
- II. Approval of Meeting Minutes
- III. Financial Condition
- IV. NCWM Industry Representative Reports
 - (a) Board of Directors Report
 - (b) Professional Development Committee Report
 - (c) Laws and Regulations Committee Report
- V. AMC Fund Disbursement Requests
- VI. Filling Vacant Positions
- VII. Old Business
- VIII. New Business
- IX. Adjournment

AMC Draft Meeting Minutes

July 16, 2013
Louisville, KY

Call to Order

Chairman Robert Murnane called the meeting to order at 5:00 p.m.

Meeting Minutes

A copy of the 2013 Interim Meeting Minutes was distributed. These minutes were reviewed and a motion was made by Mr. Flocken and seconded by Mr. Johnson to approve the minutes as written. With no further discussion, the minutes were approved.

Financial Condition

A copy of the financial report was distributed; Chairman Murnane reported that the AMC fund has a balance of \$26,602.49. Ms. Jucoch questioned what the plans are for the current balance. Chairman Murnane explained the process for scholarships, and how the money is approved through the online form for requests for training. There were also questions regarding where the money comes from to support the balance. Chairman Murnane reports that \$15 from each membership is deposited in the AMC account.

Mr. Flocken stated that the annual dues are expected to increase the balance. Mr. Lewis reports one of the benefits of being a member is you get discount on NTEP certification fees. Chairman Murnane reported that there are discounts for testing as well.

Mr. Johnson reports there are currently 2156 members in the Conference; 803 associate members depending on the issue.

The financial report was reviewed and a motion was made by Mr. Johnson and seconded by Mr. Flocken to approve the financial report as written.

Board of Directors Report

Mr. Johnson, AMC representative on NCWM Board of Directors, gave a report regarding Board activities:

Mr. Johnson reports that the Conference has lost some very experienced weights and measures officials.

Terrence McBride had to resign from the BOD due to budget/travel issues with his program, and Clark Cooney of Oregon retired.

The SWMA Meeting will be in Charleston, West Virginia, October 7 - 9, 2013, and the Measuring Sector Meeting will meet after the SWMA Meeting.

AMC – Nothing new other than they are waiting for a response to a request for any kind of assistance on the new tool kit – whether funds or other support.

Several states and NIST are requesting help with travel expenses for training. The states and NIST can provide the training, but lack of travel funds is limiting attendance at these important training programs.

NIST – Package Inspection Training, help is needed in funding the purchase of materials (groceries) for these classes.

NIST/WMD – Ms. Carol Hockert reported that Mr. Marc Butler resigned. She is looking to fill this position as soon as possible.

Work GROUP Updates – The Taximeters Work Group is looking for a statement from NIST regarding the use of alternative devices. A newsletter article may help address what tools the states have when looking at devices that are not covered in NIST Handbook 44 or NTEB approved.

NCWM Treasurers Report – The NCWM is in good financial shape.

Activity Reports – Current membership is 2156.

Annual and Interim Meetings – 2015 Planning for the 100th meeting is in process – Need AMC input. Chairmen Murnane ask that we discuss under new business

Toolkit Work Group – NCWM Chair, Mr. Steve Benjamin met with the NEWMA and CWMA. First priorities for these groups are for a video and templates (CWMA). Mr. Benjamin will meet with the SWMA and WWMA this week. A task group will meet Sunday afternoon.

NTEP Staffing – NCWM advertised a new position for additional NTEP personnel. There is a lot of interest and candidates.

Professional Development Committee (PDC) Report

Mr. Steve Grabski mentioned that getting the trainers out traveling will be a big help. Chairman Murnane mentions that he appreciates the work that the PDC has completed. Pretty much everyone present at the Conference for business has a course that pertains to him or her.

Laws and Regulations (L&R) Committee Report

Mr. Grabski will be move to the L&R Committee from PDC; No updates for the L&R Committee.

AMC Fund Disbursement Report

Chairmen Murnane reports the Washington request was paid, and the California request is still pending. California's training will take place in August.

Filling Vacant Positions

Mr. Paul Lewis agreed to fill the Associate Chair.

Mr. Bill Callaway agreed to fill Vice Chair.

Mr. David Calix agreed to fill Secretary Treasure.

Associate Committee Member - Darrel Flocken – will stay on as a committee member.

Associate Committee Member - Chairman Murnane – will stay on as a committee member.

Old Business

Mr. Gurney reports there is a request for training for the Northern Mariana Islands a U.S. territory; they are looking for training on package inspections. Mr. Don Onwiler and NIST put their heads together on who could do this training and decided on Mr. Gurney. The Northern Mariana Islands will be putting a request together for approximately \$4300; they want the AMC to think it over.

Chairmen Murnane asked, “Does NIST have an online course for the training? Are the Northern Mariana Islands members of the Conference? Could the training be completed through a webinar or WebEx?” Chairmen Murnane

asks that they check into online training and then apply online. Mr. Gurney stated originally there were going to be approximately 25 people needing training, and then there were some issues with getting all the folks to the training. Mr. Flocken stated that the more information that can be provided in the application the better and it can be look at as a cost vs. value. Mr. Lewis states that they should make sure they request enough funds; AMC will not approve extra funds. Chairmen Murnane ask that Mr. Gurney get the information regarding WebEx, Webinar, NIST and online training, put in the application and the Committee will vote on it.

Mr. Oppermann believes that it is a worthwhile request. Chairmen Murnane asked if NIST is available for the training.

Mr. Onwiler reports that the Northern Mariana Islands does not have a NCWM membership at this time. Mr. Onwiler stated that NCWM does have a WebEx account that he uses to host meetings for NCWM groups. Chairmen Murnane reported that there may be an issue if they are not members, and Mr. Lewis stated not all the inspectors that are trained with AMC funds are members.

Mr. Gurney will get the information for the requested training and put in a request for funds when all details become available.

New Business

Chairman Murnane stated that Ms. Julie Quinn (Minnesota) is requesting money to send people on travel. Mr. Flocken stated that we will pay for travel for trainers, but not for travel for people to get training.

Chairmen Murnane states that it's difficult to control. You don't know what the benefits are and what we will get out of it. We will pay for trainers to travel and facilities but not for trainees to get training.

Chairmen Murnane stated we will buy the items for packing checking and tools.

Chairmen Murnane asked, "Is there something that the AMC wants to do for the NCWM's 100th Meeting?" Mr. Lewis asked, "Do we want to make a pin or a paper weight?"

Mr. Flocken stated that the SMA was looking into sponsoring a lunch but we cannot do that. The Conference will not accept sponsorship.

Mr. Flocken stated he would rather spend the money on training as it's designed.

Mr. Onwiler reported that the Conference will not accept any sponsorship, the policy is very clear, if a group wants to go off and do something on their own, NCWM cannot endorse it and that activity would violate a gentlemen's agreement against hospitality suites. The work group is asking to suspend the rules for one event. The decision has not been made.

Chairmen Murnane stated he would like for the policy to stand, if the news media were to get ahold of it and spin it the wrong way it would look very bad for the Conference.

Mr. Onwiler stated NIST put together the very first handbook standards adopted by NCWM as a gift to the attendees of NCWM's 100-Year Anniversary Event.

Is there a difference between providing food and beverage vs. providing a gift? Mr. Onwiler does not know if that would be allowed, but that's still sponsorship, and it's a board decision. Mr. Onwiler encourages that we voice comments to the Board regarding sponsorship.

Mr. Lewis states members are welcome to set up their own booth and give away items. Mr. Onwiler stated that NCWM is not sponsoring it.

Mr. Onwiler wants the 100th to be a success.

Chairmen Murnane does not want to relax the rules, and we want to stay above reproach at all times. We don't want companies to have hospitality suites serving shrimp cocktails all night that's negative for the Conference.

Mr. Flocken stated that he supports what Chairmen Murnane says. Mr. Flocken stated giving away a gift or pin is not money well spent. We need to save the money for training opportunities.

Ms. Hemida asked, "Can we call suppliers and put on training for the Conference?" Chairmen Murnane stated that the training would be more beneficial at the regional level. Most of the folks attending the National meeting are not the ones needing training.

Ms. Hemida asks why not come up with something about the history of weights and measures past 100 years of events. How did we get to where we are now – a video or a DVD of five to seven minutes of the history?

Chairmen Murnane asked how about weights and measure history as a video, understanding the history of weights and measures.

Mr. Oppermann reported that Mr. Onwiler told him the estimated cost is \$1000/min. We would not need a very lengthy video.

Ms. Juroch asked if the Smithsonian has anything on the history of scales.

You have to touch everything, scales, gas pumps, all parts of weights and measures.

Chairmen Murnane and the group liked the DVD idea; Ms. Hemida will get with Mr. Onwiler and let us know on the feedback.

Adjournment

Mr. Oppermann said thank you Chairmen Murnane for his effort and his contribution.

Mr. Lewis moved to adjourn the meeting, a motion was made, and the meeting was adjourned at 5:58 p.m.

Respectfully submitted by,
Mr. David Calix
Secretary, AMC

Individuals in Attendance

Mr. David Calix – NCR
Mr. Paul Lewis – Rice Lake
Mr. Gordon Johnson – Gilbarco
Ms. Zina Juroch – Pier 1 Imports
Mr. Henry Oppermann – W+M Consulting
Mr. Darrell Flocken – Mettler-Toledo LLC
Mr. Louis Straub – Fairbanks Scales
Mr. Rob Upright – Vishay Transducers
Mr. Steven Grabski – Walmart Stores
Ms. Maile Hemida – Hogan Lovell’s USUP
Mr. Adam Bolain – HJ Heinz
Mr. Russ Lewis – Marathon Petroleum
Mr. Curt Williams – CP Williams Energy Consulting
Mr. John Hughes – Rice Lake Weighing Systems
Mr. Pete O’Bryan – Foster Farms
Mr. Bill Callaway – Crompco
Mr. Bob Murnane – Seraphin

Report of the Laws and Regulations (L&R) Committee

Judy Cardin, Chair
Wisconsin Weights and Measures

200 INTRODUCTION

This is the report of the Laws and Regulations Committee (hereinafter referred to as the “Committee”) for the 98th Annual Meeting of the National Conference on Weights and Measures (NCWM). This report is based on the Interim Report offered in the NCWM Publication 16, “Committee Reports,” testimony at public hearings, comments received from the regional weights and measures associations and other parties, the NCWM 2013 Online Position Forum, the addendum sheets issued at the Annual Meeting, and actions taken by the membership at the voting session of the Annual Meeting. The Informational items shown below were adopted as presented when this report was approved.

Table A identifies the agenda items and appendix items. The agenda items in the Report are identified by Reference Key Number, title, and page number. The first three digits of the Reference Key Numbers of the items are assigned from the subject series listed below. Voting items are indicated with a “**V**” after the item number. Items marked with an “**I**” are Informational. Items marked with a “**D**” are Developing items. The developing designation indicates an item has merit; however, the item is returned to the submitter for further development before any further action is taken by the Committee. Items marked “**W**” have been Withdrawn from consideration. Table B provides a list of acronyms used in this report, and Table C provides a summary of the results of the voting on the Committee’s items and the report in its entirety.

This report contains recommendations to amend National Institute of Standards and Technology (NIST) Handbook 130, 2013 Edition, “Uniform Laws and Regulations,” or NIST Handbook 133, “Checking the Net Contents of Packaged Goods,” Fourth Edition (January 2013). Proposed revisions to the handbook(s) are shown in **bold face print** by ~~striking out~~ information to be deleted and underlining information to be added. New items proposed for the handbooks are designated as such and shown in **bold face print**. Text presented for information only is shown in *italic* print. When used in this report, the term “weight” means “mass.”

Note: The policy of NIST is to use metric units of measurement in all of its publications; however, recommendations received by the NCWM technical committees have been printed in this publication as they were submitted and, therefore, some may contain only reference to inch-pound units.

Subject Series List

Introduction	200 Series
NIST Handbook 130 – General	210 Series
Uniform Laws.....	220 Series
Uniform Weights and Measures Law.....	221 Series
Uniform Weighmaster Law.....	222 Series
Uniform Engine Fuels and Automotive Lubricants Inspection Law.....	223 Series
Uniform Regulations	230 Series
Uniform Packaging and Labeling Regulation	231 Series
Uniform Regulation for the Method of Sale of Commodities.....	232 Series
Uniform Unit Pricing Regulation	233 Series
Uniform Regulation for the Voluntary Registration of Servicepersons and Service Agencies for Commercial Weighing and Measuring Devices.....	234 Series
Uniform Open Dating Regulation.....	235 Series

Uniform Regulation for National Type Evaluation..... 236 Series
 Uniform Engine Fuels and Automotive Lubricants Regulation 237 Series
 Examination Procedure for Price Verification..... 240 Series
 NCWM Policy, Interpretations, and Guidelines, Section 2 250 Series
 NIST Handbook 133..... 260 Series
 Other Items – Developing Items..... 270 Series

Table A
Table of Contents

Reference Key	Title of Item	L&R Page
200	INTRODUCTION.....	1
221	NIST HANDBOOK 130 – WEIGHTS AND MEASURES LAW	5
221-1	V Section 1. Definitions.....	5
231	NIST HANDBOOK 130 – UNIFORM PACKAGING AND LABELING REGULATION	11
231-1	W Sections 6.12. Supplementary Quantity Declarations and 6.14. Qualification of Declaration Prohibited.....	11
231-2	I Section 10.3. Aerosols and Similar Pressurized Containers	15
232	NIST HANDBOOK 130 – UNIFORM REGULATION FOR THE METHOD OF SALE COMMODITIES	18
232-1	I Section 2.27. Retail Sales of Natural Gas Sold as a Vehicle Fuel.....	18
232-2	I Section 2.33. Oil, 2.33.1.4. Engine Service Category, 2.33.1.4.1. Vehicle or Engine Manufacturer Standard, and 2.33.1.4.42. Inactive or Obsolete Service Categories	21
232-3	V Section 2.33. Oil, 2.33.1.4.5. Tank Trucks or Rail Cars and 2.33.1.6. Documentation	24
232-4	V Section 2.XX. Printer Ink and Toner Cartridges Labeling.....	28
232-5	V Section 2.XX. Retail Sale of Electricity/Vehicle	34
232-6	I Section 2.30. E85 Fuel Ethanol Flex Fuel Blends.....	40
237	NIST HANDBOOK 130 – UNIFORM ENGINE FUELS AND AUTOMOTIVE LUBRICANTS REGULATION	41
237-1	I Section 1. Definitions - Diesel Liter Equivalent (DLE) and Diesel Gallon Equivalent (DGE)41	
237-2	I Sections 2.1.3. Minimum Antiknock Index (AKI), Section 2.1.4. Minimum Motor Octane Number, and Section 3.2.5. Prohibition of Terms – Table 1.	42
237-3	I Section 2.1.4. Minimum Motor Octane Number	45
237-4	I Section 3.13 Oil, 3.13.1.4. Engine Service Category, 3.33.1.4.1. Vehicle or Engine Manufacturer Standard, and 3.13.1.4.42. Inactive or Obsolete Service Categories	47
237-5	V Section 3.13.1.4.5. Tank Trucks or Rail Cars and 3.13.1.6. Documentation	50
237-6	W Section 3.15. Biodiesel and Biodiesel Blends.....	54
237-7	W Sections 3.2. Automotive Gasoline and Automotive Gasoline-Oxygenate Blends, 3.8. E85 Fuel Ethanol, and 3.9. M85 Fuel Methanol	60
237-8	I Section 4.3. Dispenser Filters	62
237-9	I Section 1. Definitions, Section 2. Standard Fuel Specifications, and Section 3. Classification and Method of Sale of Petroleum Items.....	62
260	NIST HANDBOOK 133.....	66
260-1	V Section 2.3.8. Moisture Allowance – Pasta Products.....	66
260-2	V Section 3.10. Animal Bedding	72
260-3	W Gravimetric Testing of Printer Ink and Toner Cartridges	72
260-4	V Section 4.3. Paper Plates and Sanitary Paper Products	73
270	OTHER ITEMS – DEVELOPING ITEMS.....	73
270-1	D Fuels and Lubricants Subcommittee	73

270-2 D Packaging and Labeling Subcommittee 74
 270-3 D Moisture Allowance Task Group (MATG)..... 75
 270-4 D Handbook 130, Engine Fuels and Automotive Lubricants, Section 4.3. Dispenser Filters 76
 270-5 D Handbook 130, Section 4.3. Paper Plates and Sanitary Paper Products..... 78
 270-6 D Section 3.10. Animal Bedding 81

Appendices

A — **Item 231-2:** NIST Handbook 130, Uniform Packaging and Labeling Regulation, Section 10.3. Aerosols and Similar Pressurized Containers A1

B — **Item 232-1:** NIST Handbook 130, Uniform Method of Sale of Commodities, Section 2.27. Retail Sales of Natural Gas Sold as Vehicle Fuel; and
Item 237-1: NIST Handbook 130, Uniform Engine Fuels and Automotive Lubricants Regulation, Section 1. Definitions of “Diesel Liter Equivalent (DLE) and Diesel Gallon Equivalent (DGE)”..... B1

C — **Item 232-2:** NIST Handbook 130, Uniform Method of Sale of Commodities, Sections 2.33. Oil, 2.33.1.4. Engine Service Category, 2.33.1.4.1. Vehicle or Engine Manufacturer Standards, and 2.33.1.4.2. Inactive or Obsolete Service Category; and
Item 237-4: NIST Handbook 130, Uniform Engine Fuels and Automotive Lubricants Regulation, Sections 3.13. Oil, 3.13.1.4. Engine Service Category, 3.33.1.4.1. Vehicle or Engine Manufacturer Standard, and 3.13.1.4.2. Inactive or Obsolete Service Categories C1

D — **Item 232-5:** NIST Handbook 130, Uniform Method of Sale of Commodities, Section 2.XX. Retail Sale of Electricity/Vehicle..... D1

E — **Item 237-2:** NIST Handbook 130, Uniform Engine Fuels and Automotive Lubricants Regulation, NIST Handbook 130, Uniform Method of Sale of Commodities, Section 2.XX. Retail Sale of Electricity/Vehicle E1

F — **Item 260-4:** NIST Handbook 133, Section 4.3. Paper Plates and Sanitary Paper Products F1

G — **Item 237-8:** NIST Handbook 130, Uniform Engine Fuels and Automotive Lubricants Regulation, Section 4.3. Dispenser Filters G1

Table B
Glossary of Acronyms and Terms

Acronym	Term	Acronym	Term
ACEA	European Automobile Manufacturers Association	ISO	International Organization for Standardization
ASTM	ASTM International	L&R	Laws and Regulations
API	American Petroleum Institute	LNG	Liquefied Natural Gas
AKI	Minimum Antiknock Index	MATG	Moisture Allowance Task Group
AOCA	Automotive Oil Change Association	MAV	Maximum Allowable Variation
BOV	Bag on Valve	MON	Motor Octane Number
BTU	British Thermal Unit	NAA	National Aerosol Association
CFR	Code of Federal Regulations	NADA	National Automobile Dealers Association
CNG	Compressed Natural Gas	NARUC	National Association of Regulatory

Acronym	Term	Acronym	Term
			Utility Commissioners
CRC	Coordinating Research Council	NBB	National Biodiesel Board
CWMA	Central Weights and Measures Association	NCWM	National Conference on Weights and Measures
DGE	Diesel Gallon Equivalent	NEWMA	Northeastern Weights and Measures Association
DLE	Diesel Liter Equivalent	NIST	National Institute of Standards and Technology
DOT	Department of Transportation	NPA	National Pasta Association
EPA	Environmental Protection Agency	NTEP	National Type Evaluation Program
EVF&S	Electric Vehicle Fueling and Submetering	OEM	Original Equipment Manufacturer
EVSE	Electric Vehicle Supply Equipment	OWM	Office of Weights and Measures
FALS	Fuels and Lubricants Subcommittee	PALS	Packaging and Labeling Subcommittee
FDA	Food and Drug Administration	PEV	Plug-in Electric Vehicle
FPI	Foodservice Packaging Industry	PUC	Public Utility Commissions'
FPLA	Fair Packaging and Labeling Act	RON	Research Octane Number
FTC	Federal Trade Commission	SAE	Society of Automotive Engineers
GGE	Gasoline Gallon Equivalent	SG	Specific Gravity
GLE	Gasoline Liter Equivalent	SWMA	Southern Weights and Measures
GM	General Motors	UPLR	Uniform Packaging and Labeling Regulation
GUM	Guide to the Expression in Uncertainty Measurement	UWML	Uniform Weights and Measures Law
IEC	International Electrotechnical Association	USNWG	U.S. National Work Group
ILMA	Independent Lubricant Manufacturers Association	VIM	International Vocabulary of Metrology
ILSAC	International Lubricants Standardization and Approval Committee	WWMA	Western Weights and Measures Association

Table C
Voting Results

Reference Key Number	House of State Representatives		House of Delegates		Results
	Yeas	Nays	Yeas	Nays	
221-1	34	0	34	0	Adopted
232-3	35	0	35	0	Adopted
232-5	34	0	34	0	Adopted
237-5	35	0	35	0	Adopted
260-1	28	6	29	4	Adopted

Details of All Items
(In order by Reference Key)

221 NIST HANDBOOK 130 – WEIGHTS AND MEASURES LAW

221-1 V Section 1. Definitions

(This item was adopted.)

Source:

National Institute of Standards and Technology, Office of Weights and Measures (OWM) (2012)

Purpose:

Bring the Uniform Weights and Measures Law into agreement with current international agreement on terminology on these metrology-related definitions.

Item Under Consideration:

Amend NIST Handbook 130, Uniform Weights and Measures Law as follows:

1.14. Calibration. – ~~An A set of operations which establishes, operation that,~~ under specified conditions, ~~the in a first step, establishes a relation relationship~~ between the quantity values ~~indicated by a measuring instrument or measuring system, or values represented by a material measure, and the corresponding known values of a measurand.~~ with measurement uncertainties provided by measurement standards and corresponding indications with associated measurement uncertainties and, in a second step, uses this information to establish a relation for obtaining a measurement result from an indication.

(Added 2005) (Amended 2013)

1.15. Metrological Traceability. – The property of ~~the a measurement~~ result ~~of a measurement or the value of a standard~~ whereby the result ~~it~~ can be related to a reference ~~stated references, usually national or international standards,~~ through a documented ~~an~~ unbroken chain of calibrations, each contributing to the measurement uncertainty. ~~comparisons all having stated uncertainties.~~

(Added 2005) (Amended 2013)

1.16. Measurement Uncertainty. – A non-negative parameter ~~associated with the result of a measurement that characterizes characterizing~~ the dispersion of the quantity values ~~that could reasonably be being~~ attributed to a measurand, the measurand. based on the information used.

(Added 2005) (Amended 2013)

1.19. Standard, Reference Measurement. – A measurement standard, ~~generally of the highest metrological quality available at a given location, from which measurements made at that location are derived.~~ designated for the calibration of other measurement standards for quantities of a given kind in a given organization or at a given location. The term “reference measurement standards” usually means the physical standards of the state that serve as the legal reference from which all other standards for weights and measures within that state are derived.

(Added 2005) (Amended 2013)

1.20. Standard, Working Measurement. – A measurement standard that is ~~usually calibrated against a reference standard, and is~~ used routinely to calibrate or ~~check material measures, measuring instruments or reference materials.~~ verify measuring instruments or measuring systems. The term “working measurement standards” means the physical standards that are traceable to the reference standards through ~~comparisons—calibrations or verifications~~, using acceptable laboratory procedures, and used in the enforcement of weights and measures laws and regulations.

(Added 2005) (Amended 2013)

1.21. Metrological Traceability Chain. – Sequence of measurement standards and calibrations that is used to relate a measurement result to a reference.

(Added 2013)

1.22. Metrological Traceability to a Measurement Unit. – Metrological traceability where the reference is the definition of a measurement unit through its practical realization.

(Added 2013)

Background/Discussion:

The 1993 version of the *International Vocabulary of Metrology* (VIM) was updated in 2008 to reflect changes in international agreement about several of the key definitions it contains, in order to better align the definitions with the philosophy of the *Guide to the Expression of Uncertainty in Measurement* (GUM). The current definitions of five entries in the Uniform Weights and Measures Law (UWML) were taken from the 1993 version of the VIM, and so do not reflect the changes introduced in the 2008 version of the VIM. The changes proposed below are to update those five entries so that they reflect current international agreement on terminology. Two new definitions that are related to the other five definitions are also being proposed to be added.

By incorporating these seven definitions, the UWML will be brought into agreement with current international agreement on these metrology-related definitions. Since the GUM is referenced in ISO/IEC 17025 (General requirements for the competence of testing and calibration laboratories), which is used as the basis for accrediting State metrology laboratories, incorporating these updated definitions into the UWML will also underpin the long-term harmonization of vocabulary between the NCWM and the international standards used to regulate the testing and calibration laboratories upon which NCWM depends (such as for National Type Evaluation Program [NTEP]).

Harmonization of NCWM terminology with internationally accepted terminology helps promote global acceptance of U.S. products abroad. Proposed modifications could interfere with commonly used NCWM terminology/concepts, but the presenter of this proposal believes that is not the case here.

Previous Item Under Consideration:

1.14. Calibration. – An ~~set of operations which establishes, under specified conditions, the relationship between values indicated by a measuring instrument or measuring system, or values represented by a material measure, and the corresponding known values of a measurand.~~ operation that, under specified conditions, in a first step, establishes a relation between the quantity values with measurement uncertainties provided by measurement standards and corresponding indications with associated measurement uncertainties and, in a second step, uses this information to establish a relation for obtaining a measurement result from an indication.

NOTE 1: A calibration may be expressed by a statement, calibration function, calibration diagram, calibration curve, or calibration table. In some cases, it may consist of an additive or multiplicative correction of the indication with associated measurement uncertainty.

NOTE 2: Calibration should not be confused with adjustment of a measuring system, often mistakenly called “self-calibration,” nor with verification of calibration.

NOTE 3: Often, the first step alone in the above definition is perceived as being calibration.

(Added 2005) (~~Amended 20XX~~)

1.15. Metrological Traceability. – ~~The property of the result of a measurement or the value of a standard whereby it can be related to stated references, usually national or international standards, through an unbroken chain of comparisons all having stated uncertainties.~~ **property of a measurement result whereby the result can be related to a reference through a documented unbroken chain of calibrations, each contributing to the measurement uncertainty.**

NOTE 1: For this definition, a “reference” can be a definition of a measurement unit through its practical realization, or a measurement procedure including the measurement unit for a non-ordinal quantity, or a measurement standard.

NOTE 2: Metrological traceability requires an established calibration hierarchy.

NOTE 3: Specification of the reference must include the time at which this reference was used in establishing the calibration hierarchy, along with any other relevant metrological information about the reference, such as when the first calibration in the calibration hierarchy was performed.

NOTE 4: For measurements with more than one input quantity in the measurement model, each of the input quantity values should itself be metrologically traceable and the calibration hierarchy involved may form a branched structure or a network. The effort involved in establishing metrological traceability for each input quantity value should be commensurate with its relative contribution to the measurement result.

NOTE 5: Metrological traceability of a measurement result does not ensure that the measurement uncertainty is adequate for a given purpose or that there is an absence of mistakes.

NOTE 6: A comparison between two measurement standards may be viewed as a calibration if the comparison is used to check and, if necessary, correct the quantity value and measurement uncertainty attributed to one of the measurement standards.

NOTE 7: The ILAC considers the elements for confirming metrological traceability to be an unbroken metrological traceability chain to an international measurement standard or a national measurement standard, a documented measurement uncertainty, a documented measurement procedure, accredited technical competence, metrological traceability to the SI, and calibration intervals (see ILAC P 10:2002).

NOTE 8: The abbreviated term “traceability” is sometimes used to mean “metrological traceability” as well as other concepts, such as “sample traceability” or “document traceability” or “instrument traceability” or “material traceability”, where the history (“trace”) of an item is meant. Therefore, the full term of “metrological traceability” is preferred if there is any risk of confusion.

(Added 2005) (~~Amended 20XX~~)

1.16. Measurement Uncertainty. – ~~A parameter associated with the result of a measurement that characterizes the dispersion of the values that could reasonably be attributed to the measurand.~~ **non-negative parameter characterizing the dispersion of the quantity values being attributed to a measurand, based on the information used.**

NOTE 1: Measurement uncertainty includes components arising from systematic effects, such as components associated with corrections and the assigned quantity values of measurement standards, as well as the definitional uncertainty. Sometimes estimated systematic effects are not corrected for but, instead, associated measurement uncertainty components are incorporated.

NOTE 2: The parameter may be, for example, a standard deviation called standard measurement uncertainty (or a specified multiple of it), or the half-width of an interval, having a stated coverage probability.

NOTE 3: Measurement uncertainty comprises, in general, many components. Some of these may be evaluated by Type A evaluation of measurement uncertainty from the statistical distribution of the quantity values from series of measurements and can be characterized by standard deviations. The other components, which may be evaluated by Type B evaluation of measurement uncertainty, can also be characterized by standard deviations, evaluated from probability density functions based on experience or other information.

NOTE 4: In general, for a given set of information, it is understood that the measurement uncertainty is associated with a stated quantity value attributed to the measurand. A modification of this value results in a modification of the associated uncertainty.

(Added 2005) (~~Amended 20XX~~)

1.19. Standard, Reference Measurement. – ~~A standard, generally of the highest metrological quality available at a given location, from which measurements made at that location are derived.~~ **measurement standard designated for the calibration of other measurement standards for quantities of a given kind in a given organization or at a given location.** The term “reference standards” means the physical standards of the state that serve as the legal reference from which all other standards for weights and measures within that state are derived.

(Added 2005) (~~Amended 20XX~~)

1.20. Standard, Working Measurement. – ~~A standard that is usually calibrated against a reference standard, and is used routinely to calibrate or check material measures, measuring instruments or reference materials.~~ **measurement standard that is used routinely to calibrate or verify measuring instruments or measuring systems.** The term “working standards” means the physical standards that are traceable to the reference standards through comparisons, using acceptable laboratory procedures, and used in the enforcement of weights and measures laws and regulations.

NOTE 1: A working measurement standard is usually calibrated with respect to a reference measurement standard.

NOTE 2: In relation to verification, the terms “check standard” or “control standard” are also sometimes used.

(Added 2005) (~~Amended 20XX~~)

1.21. Metrological Traceability Chain. – **Sequence of measurement standards and calibrations that is used to relate a measurement result to a reference.**

NOTE 1: A metrological traceability chain is defined through a calibration hierarchy.

NOTE 2: A metrological traceability chain is used to establish metrological traceability of a measurement result.

NOTE 3: A comparison between two measurement standards may be viewed as a calibration if the comparison is used to check and, if necessary, correct the quantity value and measurement uncertainty attributed to one of the measurement standards.

(Added 20XX)

1.22. Metrological Traceability to a Measurement Unit. – **Metrological traceability where the reference is the definition of a measurement unit through its practical realization.**

NOTE 1: The expression “traceability to the SI” means “metrological traceability to a measurement unit of the International System of Units”.

(Added 20XX)

2011 CWMA Interim Meeting: Four officials commented that they do not support this proposal and asked why the international vocabulary could not align with NCWM. An official asked that NIST, OWM provide examples of problems caused by the lack of alignment with these two publications. CWMA did not forward the item to NCWM.

2011 WWMA Annual Meeting: An official supported the efforts to harmonize the relationship with international counterparts and believes this item should be supported on those grounds. The Committee supported the idea of the proposal but would like to have staff review this item before proceeding. WWMA forwarded the item to NCWM, recommending it as an Informational Item.

2011 NEWMA Interim Meeting: The Committee recognized that uniformity of definitions in the international marketplace will result in less confusion. NEWMA forwarded the item to NCWM, recommending it as a Developing Item.

2011 SWMA Annual Meeting: No comments were heard. The Committee recommended allowing more time for internal review by members. SWMA forwarded the item to NCWM, recommends it be forwarded to NCWM as an Informational Item.

2012 NCWM Interim Meeting: The submitter explained that the proposal allows for alignment with the international definitions. There is concern that the international language does not conform to existing language in NIST Handbook 130. The language appears to be too complicated and could cause misinterpretation. The Committee recommended that this language be returned to the submitter for language review and formatting. They would like the submitter to share the revised document at the 2012 CWMA and NEWMA Annual meetings. The 2012 L&R Committee designated this item as a Developing Item.

2012 NEWMA Annual Meeting: NEWMA supported this item and recommended that the item remain as a Developing Item.

2012 CWMA Annual Meeting: A NIST Technical Advisor submitted modified definitions and provided additional background information as follows:

Background of each definition (May 2012)

1.14. Calibration: Justification to amend the definition:

This revision updates the current definition by clarifying that a calibration not only involves comparing indications of measuring instruments with corresponding values (and uncertainties) of measurement standards, but also involves using these comparisons in an “inverse” manner, in order to be able to assign a measured value and measurement uncertainty to an item being measured by the measuring instrument, based on the indication of the measuring instrument. By updating this definition, UWML will recognize that calibration involves a two-step process.

1.15. Metrological Traceability: Justification to amend the definition:

This revision will update the current definition in four significant ways. First, in the 2008 VIM, “measurement result” means a value and an uncertainty (not just a value, as it meant in the 1993 VIM), so that traceability now applies to both the value and the uncertainty. Second, it is recognized that any acceptable “reference” can be used, and it doesn’t have to be a national or international standard. Third, the unbroken chain has to be documented, which wasn’t specified in the 1993 definition. And fourth, the chain is a chain of calibrations, and not just comparisons. This is to recognize that a comparison alone is not sufficient for traceability, since a comparison does not result in values being transferred along the chain (as a calibration does). Also, the term “Metrological” is added in front of “Traceability” in order to distinguish this type of traceability from other types (e.g., document traceability). By updating this definition, the UWML will be consistent with international practice, such as used in documents from the International Organization for Standardization (ISO) and

International Electrotechnical Commission (IEC) that pertain to accreditation requirements for (state) metrology laboratories (e.g., ISO/IEC 17025).

1.16. Measurement Uncertainty: Justification to amend the definition:

This revision updates the current definition by first clarifying that a measurement uncertainty cannot be negative, and also by removing “that could reasonably be attributed”, which some people found to be confusing. The term “Measurement” was added in order to distinguish this type of uncertainty from other types. The advantage to updating this definition is that the revisions will bring it in to agreement with the 2008 VIM definition.

1.19. Standard, Reference Measurement: Justification to amend the definition:

This revision will update the current definition in two ways. First, it would no longer be required that a reference measurement standard be of the highest quality available (for example, it could be lower in a metrological traceability chain). Second, it is specified that a reference measurement standard is intended to be used for calibration of other measurement standards (as opposed to being used to make routine measurements). The term “Measurement” was added to the term in order to distinguish this type of reference standard from other types. Updating this definition will reflect current international agreement about reference measurement standards that is consistent with the 2008 VIM.

1.20. Standard, Working Measurement: Justification to amend the definition

This revision will update the current definition in two ways. First, a working standard would no longer be required to be directly calibrated by a reference standard (it could, for example, be calibrated by another working standard). Also, this revision will clarify that a working standard can be used for both calibration and verification. The word “Measurement” was added in order to distinguish this type of standard from other types of working standards. By updating this definition, the UWML will reflect current international agreement about working measurement standards that is consistent with the 2008 VIM.

1.21. Metrological Traceability Chain: Justification to add the following definition to the UWML:

This is a new definition for that is intended to support the revision to the definition of “metrological traceability” by explaining what is meant in the definition by “chain.” By adding this definition, the UWML will reflect current international agreement on traceability that is consistent with ISO and IEC documents that pertain to accreditation requirements for (state) metrology laboratories.

1.22. Metrological Traceability to a Measurement Unit: Justification to add the following definition to the UWML:

This is a new definition that is intended to support the revision to the definition of “metrological traceability” by explaining what is meant by the expression “traceability to the SI”. For example, “(metrological) traceability to the SI” means metrological traceability to the definition of the measurement unit “kilogram” (kg) through the practical realization of the kg at NIST, obtained by calibration of a NIST mass artifact, having a mass of about 1 kg, against the international kilogram in Paris. By adding this definition to the UWML, it will reflect current international agreement on traceability that is consistent with ISO and IEC documents that pertain to accreditation requirements for (state) metrology laboratories.

CWMA requested that the submitter of the proposal provide a presentation at the 2012 NCWM Annual Meeting to brief the Conference on the changes and effects to each definition to help provide clarity. CWMA recommended that the item remain as a Developing Item.

2012 NCWM Annual Meeting: Dr. Charles Ehrlich (NIST, OWM) clarified the purpose of this item. He will provide a presentation at the 2013 NCWM Interim meeting that will further explain each proposed definition. The Committee updated its report to include Dr. Ehrlich’s explanations for each definition as presented at the CWMA Annual Meeting and updated the Item under Consideration to reflect the most recent modifications by Dr. Ehrlich.

2012 WWMA Annual Meeting: There was concern that the proposed definitions are too technical/scientific. The Uniform Weights and Measures Law is for the commercial area. It would be difficult to explain the proposed definitions to a layman or lawyer. The Committee believed this proposal was fully developed. There was also concern that NCWM would be adapting to foreign language standards. Dr. Ehrlich will make a presentation at the

NCWM 2013 Interim meeting and will perhaps respond to the concerns. The proposed language would greatly impact the laboratory. Most state laboratories have budgetary constraints and may not be able to conform without repercussions. It may also impact some laboratory accreditations/certifications. The Committee recommended that the states provide additional input to Mr. Raymond Johnson (New Mexico) and Tim Lloyd (Montana) prior to the January 2013 Interim Meeting. WWMA recommended that the item be an Informational Item.

2012 SWMA Annual Meeting: A weights and measures consultant commented that the current definitions are very well thought out and carefully worded definitions. Concern was expressed with the highly technical nature of the definitions and whether these definitions should be in weights and measures law. The average regulator may not be able to decipher the meaning of the definitions or properly interpret and apply them. It was suggested that the definitions may be more appropriate in metrology manuals. SWMA recommended that the item be a Developing Item.

2013 NCWM Interim Meeting: Dr. Ehrlich gave a brief presentation addressing concerns that were raised at the Regional Meetings. The Committee determined that this item was developed and proposed it be a Voting Item.

At the 2013 NEWMA Meeting: A comment was heard that these definitions are more than metrology and they also involve field operations. NEWMA supported this proposal as written and recommended that it be a Voting Item.

At the 2013 CWMA Meeting: There were no comments on this item, and it was recommended as a Voting Item.

At the 2013 NCWM Annual Meeting: The Committee recommended the item be presented for a Vote.

Interested parties should contact Dr. Charles Ehrlich (NIST, OWM), at (301) 975-4834 or charles.ehrlich@nist.gov, or contact Ms. Lisa Warfield (NIST, OWM) at (301) 975-3308 or lisa.warfield@nist.gov.

231 NIST HANDBOOK 130 – UNIFORM PACKAGING AND LABELING REGULATION

231-1 W Sections 6.12. Supplementary Quantity Declarations and 6.14. Qualification of Declaration Prohibited

(This item was withdrawn.)

Source:

Central Weights and Measures Association (2011)

Purpose:

Provide clearer language to guide industry and state officials when federal agencies are inconsistent in their interpretations.

Item Under Consideration:

Amend NIST Handbook 130, Uniform Packaging and Labeling Regulation as follows:

6.12. Supplementary Quantity Declarations. – The required quantity declaration may be supplemented by one or more declarations of weight, measure, or count, such declaration appearing other than on a principal display panel. Such supplemental statement of quantity of contents shall not include any term qualifying a unit of weight, measure, or count that tends to exaggerate the amount of commodity contained in the package (e.g., “giant” quart, “larger” liter, “full” gallon, “when packed,” “minimum,” **“equivalent,” “lasts the same as,”** or words of similar import).

(Amended 20XX)

6.14. Qualification of Declaration Prohibited. – In no case shall any declaration of quantity be qualified by the addition of the words “when packed,” “minimum,” or “not less than “equivalent,” or “lasts the same as” or any words of similar import (e.g., “approximately”), nor shall any unit of weight, measure, or count be qualified by any term (such as “jumbo,” “giant,” “full,” or the like) that tends to exaggerate the amount of commodity.

(Amended 1998, Amended 20XX)

Background/Discussion:

Manufacturers are using the terms such as “equivalent” or “lasts the same as” to qualify net weight statements. Clearer language is needed to provide consumers with better information. Industries and state officials need better guidance for product labeling. The Federal Trade Commission (FTC) does not consider the terms “equivalent,” or “lasts the same as” to be exaggerated or misleading.

2010 CWMA Interim Meeting: A n official presented an example of a label (below) that was perceived as mislabeled. It was agreed that no conflicting information regarding the net weight statement should be in the lower one-third of the principal display panel. CWMA forwarded the item to NCWM, recommending it as a Voting Item.

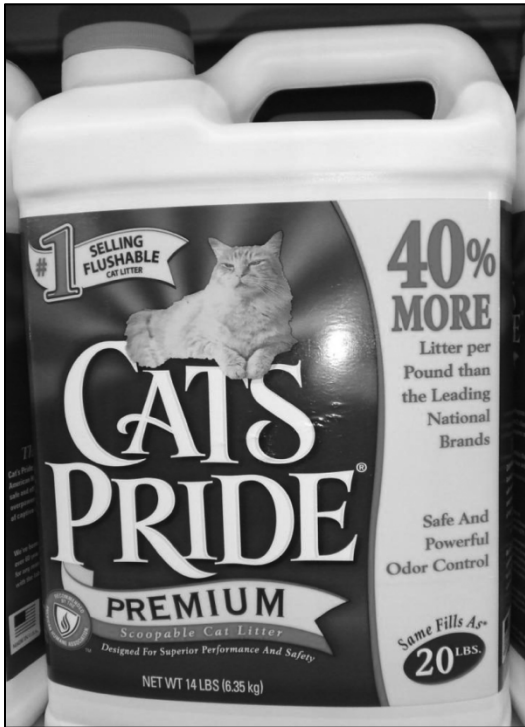



2011 NCWM Interim Meeting: It was reported that this language was lifted straight out of the Fair Packaging and Labeling Act (FPLA) and regulators might encounter problems with their investigations if the language is modified. The NIST Technical Advisor commented that the language “lasts the same as” or “equivalent” is in the marketplace, which may be misleading to consumers. The Committee was reminded that the lower 30 % of the principal display panel should be free of supplementary quantity declarations as specified in the Uniform Packaging and Labeling Regulation (UPLR) Section 6.12. Supplementary Quantity Declarations.

The NIST Technical Advisor remarked that the section was amended in 1998 to include the term “approximately” (which is not included in the FPLA) as a prohibited term. There has been no indication that the differences between the UPLR and FPLA are being challenged. It was also recommended that FTC be notified that this is an issue before the Conference. The Committee received a letter from a manufacturer stating that the company will voluntarily remove “lasts the same as” from their package label. The 2011 L&R Committee designated this item as an Informational Item to allow for review and comment by all regions.

2011 NEWMA Annual Meeting: There was a recommendation to obtain additional data from the submitter of the proposal along with clarification from the FTC on their letter dated November 4, 2010 (refer to the *Report of the 96th National Conference on Weights and Measures* [SP 1125, 2011], Appendix A). No additional comments were heard on this item. The NEWMA L&R Committee recommended that this item be Informational.

2011 CWMA Annual Meeting: The submitter of the proposal commented that the terms “last the same as” and “equivalent to” are not quantity statements and should not be in the net quantity of the principle display panel area. The CWMA L&R Committee finds that this will be helpful for enforcement issues and recommended that this item be Informational.

2011 NCWM Annual Meeting: There were no comments heard on this item. The Committee received a letter (refer to the *Report of the 96th National Conference on Weights and Measures* [SP 1125, 2011], Appendix A) from Clorox, stating the term “lasts the same as” is being removed from their packaging. The Committee would like to receive additional input from the fall 2011 regional meetings on this item.

2011 CWMA Interim Meeting: Several officials voiced support of the item and wanted clear cut guidelines for enforcement. Additionally, officials would like to see the FTC follow suit in federal law. One official recommended that the item be referred to the Package and Labeling Subcommittee (PALS). CWMA supports this item and recommends that it be a Voting Item.

2011 WWMA Annual Meeting: There were no comments. The Committee concurs with the FTC findings that the terms are not misleading. The added terms are deemed a quality statement rather than a quantity statement. WWMA recommended that the item be Withdrawn.

2011 NEWMA Interim Meeting: No comments were made and the Committee maintained a neutral position. NEWMA recommended that the item remain as an Informational Item.

2011 SWMA Annual Meeting: There were no comments heard from the floor. The Committee supported the proposal as written. SWMA recommended that the item be a Voting Item.

2012 NCWM Interim Meeting: An industry representative commented that exaggerated and misleading terms need to be addressed. He contends that in the marketplace it is becoming commonplace to see supplemental information appearing on the front of the principal display panel. Mr. Guay, PALS Chair, recommended that PALS develop this item to provide additional guidance. The NCWM L&R Committee designated this item as an Informational Item and assigned its development to PALS.

NEWMA and the CWMA Annual Meetings: Both regions supported the development of this item through PALS. At the CWMA Meeting Mr. Guay remarked that the PALS had just been formed and have not had the opportunity to meet. During the 2012 NCWM Annual Meeting, Mr. Guay provided the Committee with governing principles regarding claims on packages and to develop a series of recommendations regarding best practices for these types of label statements

2012 CWMA Interim Meeting: The NCWM L&R Committee member from the CWMA remarked that PALS was assigned to develop this item by the NCWM L&R Committee. A regulatory official asked the Committee to press forward with this item because problems were growing. CWMA supported this item and recommended that the item remain as an Informational Item and that PALS should address the proposal since compliance issues have been identified.

2012 WWMA Annual Meeting: A regulatory official commented that some terms are “performance” based, but to a quantity statement. PALS Chairman, Mr. Guay recommended that the item be renamed and reworded. The Committee believed the intent of the item is valid; however, after hearing Mr. Guay’s comments it agrees the item needs to be rewritten. The Committee concurs with FTC findings that the terms are not misleading. The Committee recommends that PALS continue to work on such issues and once developed PALS should submit a new proposal. WWMA recommended that the item be Withdrawn.

2012 SWMA Annual Meeting: SWMA withheld comment until the PALS reviews the item and makes a recommendation. SWMA recommended that the item be an Informational Item.

2012 NEWMA Interim Meeting: NEWMA recommended that the item be an Informational Item.

2013 NCWM Interim Meeting: Mr. Guay recommended that this item be Withdrawn because they have changed and expanded the scope to include other types of quantity and quality statements. PALS will submit a similar proposal in the future once it is developed. The Committee concurs with PALS and Withdrew this item in its entirety.

2013 CWMA and NEWMA Annual Meetings: Both associations were in support of the Withdrawal of this item. At the 2013 NCWM Annual Meeting no further action was taken by the Committee since the Committee had previously agreed to “Withdraw” the item.

Additional letters, presentations and data may have been part of the Committee's consideration. Please refer to (refer to Appendix A in the *Report of the 96th National Conference on Weights and Measures* [SP 1125, 2011]) to review these documents.

231-2 I Section 10.3. Aerosols and Similar Pressurized Containers

Source:

Commonwealth of Massachusetts Division of Standards (2012)

Purpose:

To allow the quantity statement in terms of weight for packages utilizing the Bag on Valve (BOV) technology where the propellant is not expelled when the valve is activated. NIST Handbook 130, Section 10.3. Aerosols and Similar Pressurized Containers require aerosols and similar pressurized containers that expel the propellant along with the product to disclose the net quantity in terms of weight.

Item Under Consideration:

Amend NIST Handbook 130, Uniform Packaging and Labeling Regulation as follows:

10.3. Aerosols and Similar Pressurized Containers. – The declaration of quantity on an aerosol **package including Bag on Valve (BOV) technology** and **other** similar pressurized packages shall disclose the net quantity of the commodity (including propellant), in terms of weight, that will be expelled when the instructions for use as shown on the container are followed.

Note: Packages that utilize the Bag on Valve (BOV) technology shall be enforceable after month/day/20XX.

(Amended 20XX)

Background/Discussion:

There are a number of products in the marketplace bearing quantity statements in terms of fluid measure that utilize the BOV technology. Packages using BOV technology are non-aerosol by definition because the propellant is not dispensed with the product. Consumers cannot do price and quantity comparison between product packaged using BOV technology and similar product in aerosol packaging because the aerosol packaged product includes the propellant in the net weight and the propellant is dispensed with the product. In the example below, two similar products are pictured, however the one on the left is labeled by net weight, and the one on the right is labeled by liquid measure.



BOV technology is environmentally friendlier because the propellant is not dispensed with the product. Products utilizing the BOV technology only expel the product as the product is contained in a bag which is surrounded by the propellant inside the container. In April 2011, NIST, OWM received a letter supporting labeling of certain products such as the "Pure Citrus" product pictured above by liquid measure.

2011 CWMA Interim Meeting: The Committee agreed that the proposal did not include a specific recommendation for the language for the amendment to NIST Handbook 130, Section 10.3. Aerosols and Similar Pressurized Containers. The Committee did not forward the item to NCWM and recommended that the item be returned to the submitter for Development.

2011 WWMA Annual Meeting: A comment from industry stated there are products in the marketplace that are similar but delivered in a different fashion. This should be looked at to account for new technology in the marketplace. The NIST Technical Advisor read from the NEWMA 2011 Annual Meeting Report that recommends the words “non-aerosol” be printed on the label so that inspectors know to test by fluid measure. The Committee believes there may be some confusion to the different unit pricing units but that consumers will be able to determine that there is new technology to expel the product. BOV technology exists in the marketplace and a proper method of sale is needed. The Committee recommended forwarding the item to NCWM as a Voting Item with the language modifications reflected below:

10.3. Aerosols and Similar Pressurized Containers. – The declaration of quantity on an aerosol package and on a similar pressurized package shall disclose the net quantity of the commodity (including propellant), in terms of weight, that will be expelled when the instructions for use as shown on the container are followed.

10.3.1. Products labeled non Aerosols in Similar Pressurized Containers (Bag on Valve [BOV] – Does not expel propellant with product.) The declaration of quantity shall disclose the net quantity of the commodity in terms of fluid measure.

After the recommendation, additional comments were accepted. An official was troubled with the wording “non-aerosol” and thought the intent of the proposal was to allow people to comparison shop between aerosols and non-aerosols. An official stated that the product could be measured by the liquid. A retired NIST, OWM employee questioned how it was measured. An official wanted to know whether the entire product was expelled when empty. An official stated that this was not ready for status as a Voting Item. The Committee met briefly and changed its recommendation. WWMA forwarded the item to NCWM, recommending it as a Developing Item.

2011 NEWMA Interim Meeting: It was stated that testing for content could be problematic and that marking on the package should be net weight of product only, not including propellant, which is not part of product. The Committee believes there is better comparison of net contents of product being sold if words “NON-AEROSOL PRODUCT” are added to product label. NEWMA forwarded the item to NCWM recommending it as a Voting Item with the following revision: add to the container language “A NON-AEROSOL PRODUCT.”

2011 SWMA Annual Meeting: Concern was expressed by an industry weights and measures consultant over an acceptable test procedure that would be used if volume was permitted. The NIST Technical Advisor noted that no specific language has been proposed and that the UPLR Section 6.4., Terms: Weight, Measures, Volume or Count declares that “any net content statement that does not permit price and quantity comparison is forbidden.” It was further noted that NIST Handbook 130, Section 10.3. Aerosols and Similar Pressurized Containers applies to aerosols and similar pressurized containers. One manufacturer has provided input to this proposal. The National Aerosol Association (NAA) has been contacted for input into this proposal. Preliminary comment by NAA is that BOV technology or versions of it has been around since the 1990s. The NAA Board of Directors member believes BOV technology is considered an aerosol, basing his opinion on a California Air Resources Board Regulation. The SWMA Committee requested that specific language be developed for this item and a complete response from the NAA. They also noted that test procedures will need to be discussed if a volume statement is to be considered. SWMA forwarded the item to NCWM recommending it as a Developing Item.

2012 NCWM Interim Meeting: The Committee reviewed several letters from different manufacturers that use BOV technology recommending liquid volume as the appropriate method of sale for products in BOV style packaging. Concern was expressed that consumers would not be able to make value comparisons if similar items had different units of measure.

Mr. Van Slyke (Lock Lord Bissell & Liddell LLP/Blue Magic, Inc.) provided a presentation indicating that they believe BOV does not fall under the aerosol guidelines. The reasoning is that a BOV container does not expel propellant with the product; therefore, it inherently has less net weight. They believe that consumers do not have sufficient information to know differences between aerosols and BOV products. Mr. Van Slyke recommended two solutions amending the UPLR language as follows:

10.3. Aerosols and Similar Pressurized Containers. – The declaration of quantity on an aerosol package and on a similar pressurized package shall disclose the net quantity of the commodity (including propellant), in

terms of weight, that will be expelled when the instructions for use as shown on the container are followed, **provided however that containers that separate propellant from the expelled product so that propellant is not expelled (such as containers using bag-on-valve technology) may be labeled either with weight or volume of the quantity of the commodity that will be expelled.**

or

10.3. Aerosols and Similar Pressurized Containers. – The declaration of quantity on an aerosol package and on a similar pressurized package shall disclose the net quantity of the commodity (including propellant), in terms of weight, that will be expelled when the instructions for use as shown on the container are followed.

10.3.1 Containers that separate propellant from the expelled product so that the propellant is not expelled (such as containers using bag-on-valve technology) shall be prominently labeled NON-AEROSOL. The declaration of quantity shall disclose the net quantity of the commodity in terms of fluid measure.

Mr. Douglas Raymond (National Aerosol Association [NAA]) gave a presentation reporting the association's position that a container using BOV technology is an aerosol, and its net quantity needs to be declared in terms of net weight. He remarked that BOV has been around for twenty plus years and is not new to the marketplace. Various products are packaged using the BOV technology (e.g., sunscreen, wound washes, shaving cream, and car products). Different aerosol forms use liquid gas, compressed gases, and in barrier forms using Sepro, bladder, and BOV. Mr. Raymond also stated that BOV and non-BOV products are designed to expel their products equally. He stated that classifying a BOV container as a non-aerosol is misleading and a safety concern since this product is pressurized.

A regulatory official agreed that BOV containers should be labeled and tested by net weight. He remarked that test procedures need to be clarified for BOV containers. For example; should the bag be removed from the canister to recover the product?

Concern was also expressed that consumers would be confused if they encountered similar products with different unit pricing and if the products contents are labeled differently. The BOV proposal that was represented during the 2012 NCWM Interim Meeting was based upon the views of the room air fresheners industry only.

The Committee would like to have a better understanding of the variety and type of products in the marketplace and what is under current development. Clarification is needed for the term "similar products" for example, what products meet this classification as defined in NIST Handbook 130, UPLR, Section 10.3. Aerosols and Similar Pressurized Containers. The Committee is also requesting from NIST, OWM clarification on the definition of aerosol and a review for any updates to NIST Handbook 130, Interpretations and Guidelines, Section 2.2.7. Aerosol Packaged Products. The 2012 L&R Committee designated this as an Informational Item.

2012 NEWMA Annual Meeting: There was discussion about conflict between the declaration of content labels in the marketplace between aerosols and bag on valve (BOV) products. NEWMA recommended that the item remain as an Informational Item.

2012 CWMA Annual Meeting: A NIST Technical Advisor stated that the Food and Drug Administration (FDA) compliance department is reviewing to see if there is a conflict with their regulations. NIST has been in contact with the National Aerosol Association (NAA), and they will have a representative at the 2012 NCWM Annual Meeting. The CWMA recommended that the item remain as an Informational Item.

2012 NCWM Annual Meeting: Mr. Douglas Raymond representing the National Aerosol Association (NAA) reported that the association is working with marketers, companies, and other trade associations; and NAA will provide an update on their position on this item at the 2013 NCWM Interim Meeting. The Committee received and reviewed five letters on this matter.

2012 CWMA Interim Meeting: The NCWM L&R Committee Member from the CWMA provided an update. The Committee supported the work of the NAA to recommend consensus language for a definition of aerosol containers and a recommendation for BOV method of sale for the NCWM L&R to consider. CWMA was neutral and recommended that this be an Informational Item.

2012 WWMA Annual Meeting: Industry and regulatory attendees agreed there are a variety of products sold with BOV packaging. Inspectors may have difficulty identifying and testing BOV items if they are not clearly marked and “BOV” on the label. The Committee is unsure on how BOV is defined and believes a test procedure may be needed for BOV packages if they do not follow NIST Handbook 130, UPLR Section 10.3. Aerosols and Similar Pressurized Containers. The Committee would like to hear the updated position from NAA. WWMA recommended that this be an Informational Item.

2012 SWMA Annual Meeting: SWMA withheld comment until NAA presents proposed language with a recommendation at the 2013 NCWM Interim Meeting. SWMA recommended that the item be an Informational Item.

2012 NEWMA Interim Meeting: NEWMA recommended that the item be an Informational Item.

2013 NCWM Interim Meeting: The Committee received and reviewed several letters from BOV manufacturers. The letter from National Aerosol Association (NAA) contained draft language that proposes dual labeling for the method of sale on the product label. The Committee discussed that there is no applicable volumetric test procedure. It was stated that allowing two methods of sales is in opposition of the OIML TC 6 Committee on Prepackaged Products which resolved that aerosols should be declared by weight. The Committee was in agreement that if industry could develop a test procedure they would readdress the issue. The Committee revised the item under consideration to include terminology to include “bag on valve.” The Committee recommends this item be an Informational Item to allow time for manufacturers to provide feedback on the time frame for labeling to change over and to research a volumetric test procedure.

2013 CWMA and NEWMA Annual Meetings: There was no additional information provided. Both regions are recommending this as an Informational Item.

Mr. Hank Pickens (Beaumont) provided a presentation at the 2013 NCWM Annual Meeting describing the procedures and reasoning for BOV to be labeled by volumetric measure. Mr. Pickens opposes NAA’s proposal for BOV to have a dual unit label. Douglas Raymond (National Aerosol Association [NAA]) is in support of a weight statement due to the challenge in testing this product. Mr. Raymond remarked that BOV products can be in liquid, paste, and powder form. A NIST Technical Advisor remarked that a volumetric method of sale would be in conflict with federal law regardless of whether it is an aerosol or not. Mr. David Sefcik (NIST, OWM) has agreed to host a meeting at NIST in Gaithersburg, Maryland, and bring interested federal agencies (i.e., FDA, FTC, and EPA) and stakeholders together. The Committee would like to see the outcome from this meeting that NIST will be hosting.

Additional letters, presentations and data may have been part of the Committee’s consideration. To review the supporting documentation please refer to Appendix B in the *Report of the 96th Annual NCWM Conference* [SP 1125, 2011], Appendix A in the *Report of the 97th National Conference on Weights and Measures* [SP 1160, 2012], and Appendix A of this report (*Report of the 98th National Conference on Weights and Measures* [2013]) to review supporting documentation.

232 NIST HANDBOOK 130 – UNIFORM REGULATION FOR THE METHOD OF SALE OF COMMODITIES

232-1 I Section 2.27. Retail Sales of Natural Gas Sold as a Vehicle Fuel

Source:

Clean Vehicle Education Foundation (2013)

Purpose:

Enable consumers to make cost and fuel economy comparisons between diesel fuel and natural gas.

Item Under Consideration:

Amend NIST Handbook 130, Uniform Regulation for the Method of Sale of Commodities as follows:

2.27. Retail Sales of Natural Gas Sold as a Vehicle Fuel.

2.27.1. Definitions.

2.27.1.1. Compressed Natural gas (CNG). – A gaseous fuel composed primarily of methane that is suitable for compression and dispensing into a fuel storage container(s) for use as an engine fuel.

2.27.1.2. Gasoline liter equivalent (GLE). – Gasoline liter equivalent (GLE) means 0.678 kg of compressed natural gas.

2.27.1.3. Gasoline gallon equivalent (GGE). – Gasoline gallon equivalent (GGE) means 2.567 kg (5.660 lb) of compressed natural gas.

2.27.1.4. Diesel liter equivalent (DLE). – means **0.756 kg of natural gas.**

2.27.1.5. Diesel gallon equivalent (DGE). – means **2.894 kg (6.38 lb) of natural gas.**

2.27.1.6. Liquefied natural gas – A gaseous fuel composed primarily of methane that has had carbon dioxide removed and nitrogen reduced to 0.5 % by volume and is suitable for liquefaction at –162 °C (–259 °F) and dispensed into a insulated cryogenic fuel storage container(s) for use as an engine fuel.

2.27.1.7. Diesel liter equivalent (DLE). – Diesel liter equivalent means **0.7263 kg of liquefied natural gas.**

2.27.1.8. Diesel gallon equivalent (DGE) – Diesel gallon equivalent means **2.749 kg (6.06 lb) of liquefied natural gas.**

(Amended 20XX)

2.27.2. Method of Retail Sale and Dispenser Labeling.

2.27.2.1. Method of retail sale. – All compressed natural gas kept, offered, or exposed for sale and sold at retail as a vehicle fuel shall be in terms of ~~the gasoline liter equivalent (GLE) or gasoline gallon equivalent (GGE);~~

(a) the gasoline liter equivalent (GLE) or gasoline gallon equivalent (GGE), or

(b) the diesel liter equivalent (DLE) or diesel gallon equivalent (DGE).

(Amended 20XX)

2.27.2.2. Dispenser labeling. – All retail compressed natural gas dispensers shall be labeled with the conversion factor in terms of kilograms or pounds. The label shall be permanently and conspicuously displayed on the face of the dispenser and shall have ~~either the statement “1 Gasoline Liter Equivalent (GLE) is equal to 0.678 kg of Natural Gas” or “1 Gasoline Gallon Equivalent (GGE) is equal to 5.660 lb of Natural Gas” consistent with the method of sale used.;~~

(a) either the statement “One Gasoline Liter Equivalent (GLE) is equal to 0.678 kg of Natural Gas” or “One Gasoline Gallon Equivalent (GGE) is equal to 5.660 lb of Natural Gas” consistent with the method of sale used.

(b) either the statement "One Diesel Liter Equivalent (DLE) is equal to 0.756 kg of Natural Gas" or "1 Diesel Gallon Equivalent (DGE) is equal to 6.312 lb of Natural Gas" consistent with the method of sale used.

(Amended 20XX)

2.27.2.3. Method of retail sale. – All liquefied natural gas kept, offered, or exposed for sale and sold at retail as a vehicle fuel shall be in terms of diesel liter equivalent (DLE) or diesel gallon equivalent (DGE).

(Added 20XX)

2.27.2.4. Dispenser labeling – All retail liquefied natural gas dispensers shall be labeled with the conversion factor in terms of kilograms or pounds. The label shall be permanently and conspicuously displayed on the face of the dispenser and shall have the statement "One Diesel Liter Equivalent (DLE) is equal to 0.7263 kg of Natural Gas" or "One Diesel Gallon Equivalent (DGE) is equal to 6.06 lb of Natural Gas" consistent with the method of sale used.

(Added 20XX)

Background/Discussion:

The gasoline gallon equivalent (GGE) unit was defined by NIST/NCWM in 1994 (refer to Appendix B in this report, *Report of the 98th National Conference on Weights and Measures [2013]*) to allow users of natural gas vehicles to readily compare costs and fuel economy of light-duty natural gas vehicles with equivalent gasoline powered vehicles. For the medium and heavy duty natural gas vehicles in widespread use today, there is a need to officially define a unit (already in widespread use) allowing a comparison of cost and fuel economy with diesel powered vehicles. Also natural gas is sold as a vehicle fuel as either Compressed Natural Gas (CNG) or Liquefied Natural Gas (LNG) and each method of sale is measured in mass. Therefore, the generic term natural gas is proposed to be used in Handbooks 44 and 130 without the existing term "compressed." (The mathematics justifying the specific quantity (mass) of natural gas in a DLE and DGE is included in Appendix B, *Report of the 98th National Conference on Weights and Measures [2013]*.)

The official definition of a DLE and a DGE will likely provide justification for California, Wisconsin, and other states to permit retail sales of LNG for heavy-duty vehicles in these convenient units.

Additional Contacts: Clean Energy, Seal Beach, California, NGV America, Washington, DC, Clean Vehicle Education Foundation, Acworth, Georgia.

2012 CWMA Interim Meeting: A regulatory official commented that there is no standard for Diesel Gallon Equivalent (DGE), LNG and CNG are being sold in Wisconsin and other states as DGE in order to compete with diesel sales. As a result, a standard is urgently needed. DGE sales are occurring in the marketplace without a standard. The Committee recommended that FALS review the conversion factors for DGE and LGE for accuracy. CWMA supported this item and forwarded the item to NCWM recommending it as a Voting Item.

2012 WWMA Annual Meeting: The Committee worked in tandem with the S&T Committee since it had a related item. Ms. Kristin Macey (California) opposed the item because it would cause complications in the marketplace. The Committee believed the item had merit but would like to know whether the values accurately represent the actual value of various types of natural gas products. It acknowledged there are different compositions and sources; for example, LNG has a higher methane composition. Is there a possibility of additional conversion factors based on British Thermal Units (BTUs) from different sources? WWMA forwarded the item to NCWM recommending it as an Informational Item.

2012 SWMA Annual Meeting: An industry representative recommended the item be designated as Developing. A regulatory official questioned why industry is not installing the right equipment rather than putting a label on a nozzle. The Committee recommended that this item be reviewed by the FALS, in part to check the accuracy of the diesel conversion. The Committee also suggested that the 1994 standard for the gasoline gallon equivalent (GGE) be reviewed. SWMA forwarded the item to NCWM, recommending it as an Informational Item.

2012 NEWMA Interim Meeting: NEWMA reviewed the CWMA comments. A General Motors representative indicated that there is a lot of discussion on a point of reference. There was comment that both methods of labeling may be required on a dispenser. The labeling issue may create more confusion for the consumer. NEWMA recommended review by the FALS. NEWMA forwarded the item to NCWM, recommending it as an Informational Item.

2013 NCWM Interim Meeting: A presentation in support of this item was given by Mr. Doug Horne (Clean Vehicle Education Foundation). Several comments were heard regarding the references and databases used to develop the calculations. Concern was expressed with the conversion factors used. Concern was also expressed that the LNG method of sale should be by weight. A NIST, OWM S&T Technical Advisor recommends that L&R and S&T work in a joint session since there is a companion Item 337-1, NIST Handbook 44, *Specifications, Tolerances and Other Technical Requirements for Weighing and Measuring Devices*, Appendix D – Definitions: Diesel Liter and Diesel Gallon Equivalents (DLE, DGE), on the S&T agenda. A collaborative effort between the two Committees will ensure that the proposed equivalent unit is dispensed accurately at the dispenser. Several attendees spoke in support of the collaborative effort. The Committee will request that the NCWM Board of Directors create a Steering Committee that consists of experts and stakeholders to review this proposal. L&R will prepare a list of comments that they would like the Steering Committee to review and address. The L&R Committee recommends this as Informational Item.

At the 2013 NCWM Annual Meeting the Committee was informed that the Natural Gas Steering Committee chaired by Mr. Mahesh Albuquerque would be reviewing this item.

Additional letters, presentations and data may have been part of the Committee’s consideration. Please refer to Appendix B, of this document (*Report of the 98th National Conference on Weights and Measures [2013]*) to review these documents.

232-2 I Section 2.33. Oil, 2.33.1.4. Engine Service Category, 2.33.1.4.1. Vehicle or Engine Manufacturer Standard, and 2.33.1.4.1.2. Inactive or Obsolete Service Categories

Source:

Automotive Oil Change Association (AOCA) (2013)

Purpose:

Prevent consumer confusion and government-sponsored product bias regarding legitimate, manufacturer-recommended products, and to prevent installers and retailers from being held responsible for labeling requirements with respect to packaged goods.

Item Under Consideration:

Amend NIST Handbook 130, Uniform Regulation for the Method of Sale of Commodities as follows:

2.33. Oil.

2.33.1. Labeling of Vehicle Engine (Motor) Oil. - Vehicle engine (motor) oil shall be labeled.

2.33.1.1. Viscosity. – The label on any vehicle engine (motor) oil container, receptacle, dispenser, or storage tank, and any invoice or receipt from service on an engine that includes the installation of vehicle engine (motor) oil dispensed from a receptacle, dispenser, or storage tank, shall contain the viscosity grade classification preceded by the letters “SAE” in accordance with SAE International’s latest version of SAE J300, “Engine Oil Viscosity Classification.”

2.33.1.2. Intended Use. – The label on any vehicle engine (motor) oil container shall contain a statement of its intended use in accordance with the latest version of SAE J183, “Engine Oil Performance and Engine Service Classification (Other than “Energy Conserving”).”

2.33.1.3. Brand. – The label on any vehicle engine (motor) oil container and the invoice or receipt from service on an engine that includes the installation of vehicle engine (motor) oil dispensed from a receptacle, dispenser, or storage tank shall contain the name, brand, trademark, or trade name of the vehicle engine (motor) oil.

2.33.1.4. Engine Service Category. – The label on any vehicle engine (motor) oil container, receptacle, dispenser, or storage tank and the invoice or receipt from service on an engine that includes the installation of vehicle engine (motor) oil dispensed from a receptacle, dispenser, or storage tank shall contain the engine service category, or categories, displayed in letters not less than 3.18 mm ($\frac{1}{8}$ in) in height, as defined by the latest version of SAE J183, “Engine Oil Performance and Engine Service Classification (Other than “Energy Conserving”),” or API Publication 1509, “Engine Oil Licensing and Certification System,” **European Automobile Manufacturers Association (ACEA) European Oil Sequences.**

2.33.1.4.1. Vehicle or Engine Manufacturer Standard. – **The label on any vehicle engine (motor) oil container, receptacle, dispenser, or storage tank and the invoice or receipt from service on an engine that includes the installation of vehicle engine (motor) oil dispensed from a receptacle, dispenser, or storage tank shall identify the specific vehicle or engine manufacturer standard, or standards, met in letters not less than 3.18 mm ($\frac{1}{8}$ in) in height. If the vehicle (motor) oil only meets a vehicle or engine manufacturer standard, the label must clearly identify that the oil is only intended for use where specifically recommended by the vehicle or engine manufacturer.**

2.33.1.4.1-2. Inactive or Obsolete Service Categories. – The label on any vehicle engine (motor) oil container, receptacle, dispenser, or storage tank and the invoice or receipt from service on an engine that includes the installation of vehicle engine (motor) oil dispensed from a receptacle, dispenser, or storage tank shall bear a plainly visible cautionary statement in compliance with the latest version of SAE J183, Appendix A, whenever the vehicle engine (motor) oil in the container or in bulk does not meet an active API service category as defined by the latest version of SAE J183, “Engine Oil Performance and Engine Service Classification (Other than “Energy Conserving”).” **If a vehicle engine (motor) oil is identified as only meeting a vehicle or engine manufacturer standard, the labeling requirements in Section 2.33.1.4.1. Vehicle or Engine Manufacturer Standard apply.**

2.33.1.4.5. Tank Trucks or Rail Cars. – Tank trucks, rail cars, and other types of delivery trucks that are used to deliver vehicle engine (motor) oil are not required to display the SAE viscosity grade and service category or categories as long as the bill of lading or other documentation provides that information.

~~All references to invoice or receipt will be enforceable effective on July 1, 2013.~~

(Added 2012) (**Amended 20XX**)

Background/Discussion:

The vast majority of engine oil used at professional fast lube facilities is the most current category of API (American Petroleum Institute) licensed oil. However, older, specialty, and some non-American vehicles take engine oil not listed as active under API’s private regulatory scheme; some are former API licensed oils now considered “obsolete” or “inactive” and some are simply licensed by another organization like the European Automobile Manufacturers Association (ACEA). However, if original equipment manufacturers (OEM) recommend those engine oils for their vehicles, consumers have a right to use them regardless of API’s blessing, and installers and retailers should be able to sell them without obstruction.

Automotive Oil Change Association (AOCA) amendment is necessary because a cautionary statement appearing on service receipts without explanation will inappropriately mislead consumers with older and uncommon model vehicles into believing they shouldn’t use OEM-recommended engine oil. The average fast lube customer does not recognize API or SAE (Society of Automotive Engineers) to mean anything in particular but “CAUTION” and “OBSOLETE” in big capital letters could only be understood as negative. Scaring consumers in this way will not

only push them to buy more expensive engine oil they do not need but also engender distrust in their installer service providers for recommending and/or using OEM-recommended engine oil.

The average age of cars in the current fleet is nearly 11-years old and it is not unusual for fast lubes to have customers with vehicles twice that age; for example, there are millions of opportunities for consumers to be misled into rejecting proper engine oil. The fact is American consumers are hanging onto their vehicles longer than API is hanging onto its service categories. When API designates a motor oil category as inactive, this does not mean consumers with vehicles designed to use that category turn in their cars or otherwise want to buy a more expensive grade of motor oil going forward. Therefore, a category of motor oil designed to work for particular makes and models of vehicles should not be burdened with the chilling effect of a cautionary statement absent a specific clarification acknowledging the preeminence of the OEM's recommendations.

The new standard phase-in factor must be considered as well. When API publishes a new edition of 1509, *Engine Oil Licensing and Certification Systems*, and/or creates a new service category, a reasonable phase-in period for bulk oil stock is necessary to accommodate older vehicle owners' needs; for example, it may be in those customers' best interests, both functionally and economically, to use motor oil developed in accordance with an earlier edition or service category so long as the automobile manufacturer originally recommended it, and its continued use has no impact on any remaining warranty coverage. Although it is common for API to retain a couple of the most recent service categories as "active," API could choose to make all but the most recent service category "obsolete." For fast lube operators to automatically upgrade bulk oil stock at API-determined intervals would be tantamount to giving API control over the price of oil change services regardless of what the market can bear.

And what about packaged engine oil products already on the shelf or in the distribution chain when API makes a unilateral decision to deactivate an engine oil category? As a practical matter, tens of thousands of retailers and installers cannot re-mark millions of packages to coincide with API's timing or take the financial hit for sending it all back in violation of purchase agreements. Attempting to enforce the labeling requirement at this level would be a nightmare for everyone involved. The way to avoid this problem is to adopt AOCA's amendment so that the requirement for proper labeling of packaged containers of engine oil rest with the party in control of the packaging – the manufacturers.

Without the amendment, the labeling requirement will be very difficult to enforce given the inventory of packaged goods remaining after an active engine oil category has been declared inactive or obsolete.

Fast lubes would experience catastrophic business loss if customers with older and uncommon model vehicles were alienated. Maintenance costs for consumers with older model cars could easily double if they are confused into believing they need the latest category of engine oil.

AOCA contends that the proposed amendment will accomplish three important goals: 1) prevent unintended consumer confusion and product stigma from using a cautionary statement by reestablishing the connection to OEM recommendations; 2) provide the necessary exemption to protect retailers and installers for selling lawful packaged inventory; and 3) which leads to an increase in practical enforcement prospects.

The most analogous regulatory situation to the one at issue in AOCA's proposed amendment is found in the Federal Trade Commissions (FTC) Test Procedures and Labeling Standards for Recycled Oil (16 CFR 311). In that rulemaking process, FTC specifically rejected requiring recycled engine oil to be labeled "recycled" because of the stigma associated with the term at that time (see 72 FR 14410 – 14413 & FN11 [1 H.R. Rep. No. 96-1415, 96th Cong. 2d Sess. 6 (1980), reproduced at 1980 U.S. Code Cong. & Ad. News 4354, 4356. "Oil should be labeled on the basis of performance characteristics and fitness for its intended use, and not on the basis of the origin of the oil."]). The National Automobile Dealers Association (NADA) also commented in favor of this approach: "NADA further stated that by not requiring that "substantially equivalent" recycled oils be labeled "recycled" or "re-refined," used oil processors are able to market their products effectively." (72 FR at 14411) No "recycled" or other potentially derogatory designation is required so long as the finished product meets the appropriate API standard.

2012 CWMA Interim Meeting: AOCA stated that the oil change industry is small businesses without legal staff so they need clear guidance that is easily understood. These businesses follow the OEM recommendations, which recommend oils that do not follow API or SAE standards. The language should acknowledge that some

manufacturers approve and recommend their own oil (i.e., General Motors [GM] and Audi-Volkswagen). AOCA thought that the current language required all OEM oils that did not meet a specific API performance standard to be labeled as obsolete. A GM representative confirmed that GM produces their own oil, Dexos (the best oil for any car), which does not have an API certification. A FALS member shared the API motor oil guide, (refer to Appendix C of this report) which labels specific categories of oil as obsolete. If a manufacturer does not label the oil with an API obsolete category, the product is not considered to be obsolete. OEM manufacturers that were named do not label their oil with an obsolete category, and so oil changers do not need to worry about the obsolete label being used on OEM motor oils. AOCA asked if there would be a grace period to sell product purchased prior to January 2013. States regulators clarified that nothing is written in the regulation, and grace periods would be determined on a state by state basis. AOCA reiterated that the language should clearly state that OEM oils that do not have API certification are not obsolete. She asked that the Committee recommend this clarifying language. AOCA also stated that installers should not be responsible for labeling on packaged products received. A regulatory official stated that retailers in other industries are responsible for labeling on packages received, and it would be an unfair market advantage to allow some retailers to use products that were illegally labeled. Since the current language is not clear about exactly what oils are obsolete, the Committee recommended that FALS make a recommendation at the NCWM Interim Meeting. CWMA forwarded the item to the NCWM recommending it as a Voting Item with the stipulation that FALS develop the language.

2013 CWMA Annual Meeting: Mr. Kevin Ferrick (API) opposed the proposed language for this item; stating if a product meets an obsolete standard the customer deserves to know this. CWMA would like to see additional information from the FALS.

2012 WWMA Annual Meeting: Ms. Kristin Macey (California) opposed the item because it removes retailer accountability. Mr. Ferrick who opposed the additional language also provided a presentation and written comments for the WWMA. Mr. Kurt Floren (Los Angeles County, California) also opposed the item for reasons stated by Ms. Macey. WWMA did not forward the item to NCWM.

2012 SWMA Annual Meeting: An API Representative voiced API's opposition to the item and provided the written testimony in dispute of the comments and claims made by the submitter (refer to Appendix C, in this *Report of the 98th National Conference on Weights and Measures* [2013]).

2012 NEWMA Interim Meeting: API stated it opposes the item and that specifics have been submitted in writing. API suggested this proposal and Item 237-4 be Withdrawn. General Motors indicated the proposal appears to allow older formulations of engine oil, but newer formulations give better performance, even in older vehicles. GM prefers current formulation of engine oil. NEWMA did not forward the item to NCWM.

2013 NEWMA Annual Meeting: Mr. Ferrick indicated that API submitted comments regarding their opposition to this item and requested that this item be Withdrawn. NEWMA would like to see additional information from FALS.

2013 NCWM Interim Meeting: A state opposed this item and would like to see it Withdrawn. The FALS Chairman remarked that there are several engine oils designed for specific model vehicles, and FALS is trying to resolve this issue. A Committee member remarked that a statement of accountability should be within the language. The Committee would like to see additional language developed by FALS and made this an Informational Item.

2013 NCWM Annual Meeting: The FALS submitted modified language for Sections 2.33.1.4. Engine Service Category, 2.33.1.4.1. Vehicle or Engine Manufacturer Standard, and 2.33.1.4.1.2. Inactive or Obsolete Service Categories. The Committee would like to have regional input on this modified language to review at the 2014 NCWM Interim Meeting.

232-3 V Section 2.33. Oil, 2.33.1.4.5. Tank Trucks or Rail Cars and 2.33.1.6. Documentation

(This item was adopted.)

Source:

Automotive Oil Change Association (2013)

Purpose:

Make compliance and enforcement practical, efficient, and fair.

Item Under Consideration:

Amend NIST Handbook 130, Uniform Regulation for the Method of Sale of Commodities as follows:

2.33. Oil.**2.33.1. Labeling of Vehicle Engine (Motor) Oil.** – Vehicle engine (motor) oil shall be labeled.

2.33.1.1. Viscosity. – The label on any vehicle engine (motor) oil container, receptacle, dispenser, or storage tank, and any invoice or receipt from service on an engine that includes the installation of vehicle engine (motor) oil dispensed from a receptacle, dispenser, or storage tank, shall contain the viscosity grade classification preceded by the letters “SAE” in accordance with the SAE International’s latest version of SAE J300, “Engine Oil Viscosity Classification.”

2.33.1.2. Intended Use. – The label on any vehicle engine (motor) oil container shall contain a statement of its intended use in accordance with the latest version of SAE J183, “Engine Oil Performance and Engine Service Classification (Other than “Energy Conserving”).”

2.33.1.3. Brand. – The label on any vehicle engine (motor) oil container and the invoice or receipt from service on an engine that includes the installation of vehicle engine (motor) oil dispensed from a receptacle, dispenser, or storage tank shall contain the name, brand, trademark, or trade name of the vehicle engine (motor) oil.

2.33.1.4. Engine Service Category. – The label on any vehicle engine (motor) oil container, receptacle, dispenser, or storage tank and the invoice or receipt from service on an engine that includes the installation of vehicle engine (motor) oil dispensed from a receptacle, dispenser, or storage tank shall contain the engine service category, or categories, displayed in letters not less than 3.18 mm ($\frac{1}{8}$ in) in height, as defined by the latest version of SAE J183, “Engine Oil Performance and Engine Service Classification (Other than “Energy Conserving”)” or API Publication 1509, “Engine Oil Licensing and Certification System.”

2.33.1.4.1. Inactive or Obsolete Service Categories. – The label on any vehicle engine (motor) oil container, receptacle, dispenser, or storage tank and the invoice or receipt from service on an engine that includes the installation of vehicle engine (motor) oil dispensed from a receptacle, dispenser, or storage tank shall bear a plainly visible cautionary statement in compliance with the latest version of SAE J183, Appendix A, whenever the vehicle engine (motor) oil in the container or in bulk does not meet an active API service category as defined by the latest version of SAE J183, “Engine Oil Performance and Engine Service Classification (Other than “Energy Conserving”).”

2.33.1.5. Tank Trucks or Rail Cars. – Tank trucks, rail cars, and other types of delivery trucks that are used to deliver vehicle engine (motor) oil are not required to display the SAE viscosity grade and service category or categories ~~as long as the bill of lading or other documentation provides that information on such tank trucks, rail cars, and other types of delivery trucks.~~

2.33.1.6. Documentation. – When the engine (motor) oil is sold in bulk, an invoice, bill of lading, shipping paper, or other documentation must accompany each delivery. This document must identify the quantity of engine (motor) oil delivered as defined in Section 2.33.1.1. Viscosity; Section 2.33.1.2. Intended Use; Section 2.33.1.3. Brand; Section 2.33.1.4. Engine Service Category; the name and address of the seller and buyer; and the date and time of the sale. For inactive or obsolete service categories, the documentation shall also bear a plainly visible cautionary statement as required in Section 2.33.1.4.1. Inactive or Obsolete Service Categories, documentation must be retained at the retail establishment for a period of not less than one year.

~~All references to invoice or receipt will be enforceable effective on July 1, 2013.~~

(Added 2012) (Amended 2013)

Background/Discussion:

There is a chain of engine oil purchasers involved in the sale of bulk engine oil, all of whom need accurate and adequate information about the commodity so that they can make price and quantity comparisons. The engine oil distributor is a purchaser with respect to engine oil manufacturers, the installer is a purchaser with respect to engine oil distributors, and the consumer is a purchaser with respect to installers. Installers like fast lube operators can only provide accurate and adequate information about bulk engine oil to consumers if their distributors provide it at the point of delivery. It would be manifestly unfair to expect installers to legally vouch in writing for the quality of distributors' engine oil products absent a corresponding written verification requirement.

The original language for consideration (refer to the *Report of the 97th National Conference on Weights and Measures* [SP 1160, 2012], L&R Committee Report) creating a Method of Sale, Section 2.33.1.4.2. Tank Trucks or Rail Cars and Engine Fuels and Automotive Lubricants Regulation Section and 3.13.1.4.2. Tanks Trucks or Rail Cars inadvertently created a loophole for distributors to avoid providing necessary product documentation at the time of delivery.

Whether or not NCWM waives tank truck labeling is not the issue. The problem lies in the controversy this provision allows. If a distributor displays the SAE viscosity grade and service category on a tank truck, then he/she does not have to provide a bill of lading. This poses a serious risk to installers, like fast lubes, because the regulation requires them to vouch for viscosity grade, service category, and brand on customer receipts but doesn't guarantee the installers will receive that same information in writing from their distributors – the parties with actual control over product quality/identity.

There is no practical way for fast lubes or NCWM to enforce this “either/or” regulatory scenario. If a distributor arrives at an installer's facility without documentation, how can the installer hold the distributor to it under NIST Handbook 130? The distributor can simply claim his/her truck is adequately marked. Installers are not professional truck inspectors; they cannot be expected to act as enforcement agents in this scenario. Meanwhile, in order for local weights and measures officials to hold a distributor accountable, they would have to arrive on the scene at the time of delivery, which coincidence is unlikely at best. Any subsequent official inquiry would take place after the distributor has had the opportunity to subsequently mark any unmarked truck at issue. Moreover, risk of distributor failure in providing necessary documentation is high because most do not and never have been willing to provide bills of lading or other documentation to fast lubes at the time of delivery. Additionally, the imperative for any installer labeling and/or receipt information requirements to be matched by corresponding requirements for engine oil distributors includes “brand.” Installers cannot purport to verify via any form of documentation information that distributors have not documented at delivery. Handbook 130 (2013), Uniform Method of Sale, Section 2.33. Oil and Uniform Engine Fuels and Automotive Lubricants Regulation and Section 3.13. Oil required installers to verify brand in writing and; therefore, distributors should be required to verify it too. For NCWM to require otherwise would be manifestly unfair to installers by subjecting them to liability for the bad acts of distributors without any paperwork trail to rely upon in their own defense.

No one has more at stake than installers. Should a product quality problem occur with packaged goods, it is relatively easy to trace the goods back to the manufacturer. However, this is not the case with motor oil transported in bulk; it all looks alike; it may have “changed hands” numerous times before reaching the fast lube facility, and even with testing can be impossible for a fast lube to verify because oil companies use chemical markers that only they can identify. Since motor oil specifications have become so precise, and so expensive, fast lube operators stand to lose thousands of dollars every time a distributor delivers a lesser product.

Moreover, when a distributor delivers the wrong product, it is the fast lube operator who gets stuck holding the bag for consumer claims, which can be excessive if the “wrong” product did or could cause engine damage. It takes weeks before a bad load is detected, which by then anywhere from 500 to 700 customers have been serviced. What is the remedy? All of the customers must be called back and re-serviced for free before any damage has the opportunity to occur. Requiring distributors to provide the same documentation required of installers represents the

minimum necessary step to at least protect installers from misrepresentation claims when a distributor “mis-delivers” bulk oil.

API and Independent Lubricant Manufacturers Association (ILMA) have been publicly quoted as supporting the requirement that distributors provide documentation at delivery as if the new paragraphs at issue already mandate it under all circumstances. See Lube Report (August 1, 2012) www.imakenews.com/lng/e_article002489327.cfm?x=b11,0,w.

The Environmental Protection Agency’s (EPA) Federal Used Oil Management Standards require detailed transporter chain of custody documentation (40 CFR Part 279). See also *EPA’s Chain-of-Custody Procedures for Samples and Data* (www.epa.gov/apti/coc/), which makes clear that failure to maintain a proper chain of custody regarding samples and/or data will destroy any ability to defend oneself if challenged.

According to the USDA, segregation and documentation for specialty (bulk) crops continue from the elevator to the final producer or consumer. (*Traceability in the U.S. Food Supply: Economic Theory and Industry Studies* [USDA Economic Research Service 2004]).

Under the Food and Drug Administration (FDA) Food Modernization Act (Public Law 111-353, www.gpo.gov/fdsys/pkg/PLAW-111publ353/pdf/PLAW-111publ353.pdf), documenting the production and distribution chain of food products is required so that “in case of a problem, a product can be traced back to the source.”

The Department of Transportation (DOT) overlaps with EPA regarding the Federal Hazardous Waste Manifest System (40 CFR Part 262, www.ecfr.gov/cgi-bin/text-idx?tpl=/ecfrbrowse/Title40/40cfr262_main_02.tpl), which mandates detailed documentation of hazardous waste from cradle to grave; for example, from generator to transporter to end user/disposal.

The submitter provided the following websites as evidence that “mis-delivery of liquid products must happen with some recognized frequency because the subject is big business for the insurance industry.”

- www.johannesagency.com/petroleum
- canalinsurance.com/coverage/truckers-general-liability
- www.marianoagency.com/programs/transportation,
- falcingno.com/products-a-services/environmentalchemical
- www.iaaofillinois.org/convention2011/documents/SpeakerOutlines/CGL%20and%20Auto%20Endorsements.pdf
- www.safapeoria.com/data/uploadDirectory/applications/commercialauto/EMPIRE%20FIRE%20AND%20MARINE/Motor%20Carrier/motor%20carrier.pdf
- www.big-ins.com/generalapps/SupplAppFuelMkrs2003.pdf
- www.insurancecommunityuniversity.com/UniversityResources/InsuranceGlossaryFREE/InsuranceGlossaryM/MisdeliveryofLiquidProductsCoverageCommercial.aspx

2012 CWMA Interim Meeting: The Automotive Oil Change Association (AOCA) stated that the current language would allow the distributor to either label the truck or tank car or the bill of lading. The language should clearly state that distributor needs to provide the retailer with a bill of lading or other documentation that includes product identity information. A FALS member acknowledged the current language could be construed to say that the distributor does not need to provide this documentation, and that was not the intent. The Committee recommends that FALS provide concise language that states that a bill of lading or other documentation with appropriate product information must be provided to the retailer. FALS should submit proposed language to the NCWM L&R

Committee for the Interim Meeting. CWMA forwarded the item to NCWM recommending it as a Voting Item with the stipulation that FALS develop the clarifying language as requested.

2012 WWMA Annual Meeting: Mr. Ferrick (API) provided a presentation to the WWMA and written comments to the Committee. Mr. Ferrick remarked that the submitted proposal was rather wordy, however; he does not disagree with the language. Ms. Kristin Macey (California) supported the submitted proposal. The Committee agreed that the submitted proposal is too lengthy and presented alternative language for consideration. The Committee regretted that the submitter was not present to answer questions and concerns. WWMA forwarded the item to NCWM recommending it as an Informational Item as modified and presented below:

2.33.1.5. Tank Trucks or Rail Cars. – Tank trucks, rail cars, and other types of delivery trucks that are used to deliver vehicle engine (motor) oil are not required to display the SAE viscosity grade and service category or categories; **however, as long as** the bill of lading or other documentation **shall** provides that information.

2012 SWMA Annual Meeting: An API representative stated the proposal is consistent with API goals for distributor and installers to disclose what they are installing. The Committee agreed that adequate documentation should be provided. SWMA forwarded the item to NCWM recommending it as a Voting Item.

2013 NCWM Interim Meeting: Mr. Ron Hayes, FALS Chairperson remarked that FALS is recommending language changes for this item. FALS developed Section 2.33.1.6. Documentation, which resolves the issues brought before the Subcommittee. FALS recommended to the Committee that the revised language move forward as a Voting Item. The Committee concurs with the language revisions and proposed this item be a Voting Item.

2013 NEWMA and CWMA Annual Meetings: Both Associations supported this as a Voting Item. During the open hearings at the 2013 NCWM Annual Meeting, the FALS Chair proposed this item move forward as a Voting Item.

232-4 V Section 2.XX. Printer Ink and Toner Cartridges Labeling

(The Committee returned this item to Informational Status.)

Source:

Southern Weights and Measures Association (2010)

Purpose:

Clarify the labeling requirements for industry, consumers and weights and measures officials.

Item Under Consideration:

Amend NIST Handbook 130, Method of Sale Regulation as follows:

2.XX. Printer Ink and Toner Cartridges Labeling.

2.XX.1. Definitions.

- (a) 2.XX.1.1. Printer Ink Cartridges. – Any cartridge or module that contains ink or a similar substance in liquid form employed in the printing and/or copying of documents, papers, pictures, etc., that is used in a printing device and designed to be replaced when no longer able to supply its contents in printing and/or copying.**
- (b) 2.XX.1.2. Toner Cartridges. – Any cartridge or module that contains toner, powder, or similar non-liquid substance employed in the copying or printing of documents, papers, pictures, etc. that is used in a printing and/or copying device and designed to be replaced when no longer able to supply its contents in printing and/or copying.**

2.XX.2. Method of Sale and Labeling.

(a) 2.XX.2.1. Method of sale, printer ink cartridges. – All printer ink cartridges kept, offered, or exposed for sale or sold shall be sold in terms of the count.

(b) 2.XX.2.2. Method of Sale, toner cartridges. – All toner cartridges kept, offered, or exposed for sale or sold shall be sold in terms of the count.

2.XX.3. Yield Disclosure – If the seller discloses the yield of printer ink or toner cartridges on the package, then it shall be measured using the latest version of ISO/IEC printer yield standard on the package offered for prepackaged sale. This information shall be considered a supplemental statement.

Note: Labeling shall be enforceable after month/day/20XX.

(Added 20XX)

Background/Discussion:

Over the past several years, there has been a change in the marketplace on inkjet and toner cartridges net content statements. There is little uniformity, and the Committee has seen some labels with a net content or with only a page yield count (e.g., prints 1000 pages). The NIST, OWM pointed out that, according to guidelines printed in NIST Handbook 130, Weights and Measures Law, Section 19. Information Required on Packages, these products are required to have the net contents of the ink (and toner) labeled, but manufacturers have resisted, claiming an exemption under the FPLA. The purpose of this proposal is to specifically clarify the requirements for industry, consumers, and weights and measures officials.

2009 SWMA Annual Meeting: A Lexmark representative commented that they do not believe that a net content statement should be required, and that a page yield is sufficient. He read the main points of a letter from Lexmark to Mr. Gray (Florida Department of Agriculture and Consumer Services) dated March 17, 2009. The main points within the letter were: 1) the ink associated with a cartridge is a small fraction of the total cost of the print cartridge mechanism; 2) a page yield can provide a meaningful comparison to a consumer if all manufacturers employ the same estimating assumptions and techniques; and 3) International Organization for Standardization (ISO) studied this issue for years and has rejected reliance on ink volume or quantity; instead ISO has developed a yield estimating and claiming methodology that permits cartridges to be compared using a consistent yardstick. Unlike ink volume measurements, page yield measurements provide a consumer with a reliable way to compare the amount of printing that can be expected. Lexmark also stated that ink is expressly exempt from labeling as provided by the FPLA, 16 CFR Part 503.2(a).

An industry representative said this issue does need to be discussed and reviewed further. However, many officials believe that consumers should know what they are getting. If it is determined that page count is the quantity statement, then the page print standard should be reviewed and have tighter standards. Mr. Gray said that more data is needed from manufacturers on this issue. SWMA forwarded the item to NCWM, recommending it as a Developing Item.

2010 NCWM Interim Meeting: Mr. Matthew Barkley (Hewlett Packard Co.) commented that the FPLA creates an exemption for ink which extends to toner and ink cartridges. A declaration of weight and volume are not the best way for consumers to make value comparisons. Customers benefit from page count/yield. Mr. Barkley urged that this issue be Withdrawn. If this issue is to proceed, it should be Informational to allow for a review of the FPLA exemption. He suggested that page yield is widely accepted and has repeatability measures.

Mr. Jeran (Hewlett Packard Co.) submitted a white paper from the Information Technology Industry Council (refer to the *Report of the 96th National Conference on Weights and Measures* [SP 1125, 2011], Appendix C). This white paper included manufacturers from Epson, Hewlett Packard, Kodak, and Lexmark. Mr. Jeran explained that his background is with ink and toner measurement. For the same volume of ink, two different systems of the same model cartridge from two different vendors can print a different number of pages. In order to determine the page yield, they are using the ISO/IEC methodology. ISO is working on a photo yield standard.

An official expressed concerns with page yield being the standard page print for quantity. Variation exists based on the type of cartridge, printer, and font and if graphics/photos are being printed. There is also a concern with what

ink cartridge refillers are doing. The Florida official reviewed the current practice of refillers, and said they are stating the amount of ink on labels. There are many manufactured packages in the marketplace, so value comparison to the Original Equipment Manufacturer (OEM) is critical. This is an expensive commodity and clarifications of the requirements are needed. An official recommended that this item not be Withdrawn, but made Informational to allow time for research. Regulatory officials firmly believe that there needs to be a consistency with the declaration statement on these types of items. A consumer stated that the net content needs to be stated with voluntary supplemental information for page yield. Some voiced their opinion that consumers need to know page yield in order to make a value comparison. The NIST Technical Advisor stated that under the FTC regulations ink and toner cartridges were not part of the CFR. NIST, OWM met with the FTC on February 26, 2010, to request clarification of the exemption. According to the Committee, there needs to be a test procedure for verification of net content developed for ink and toner cartridges. The 2010 L&R Committee designated this item as an Informational Item until they receive clarification from FTC, review ISO standards, and determine what refillers' current practices are.

2010 NEWMA and CWMA Annual Meetings: Both associations received a presentation from Mr. Pociask (American Consumer Institute) regarding a lack of consumer information when purchasing computer printers and cartridges. Both associations expressed that there are still many unanswered questions and would like to hear from manufacturers of printer ink and toner cartridges. Both associations recommended that the item remain as an Informational Item.

2010 NCWM Annual Meeting: Mr. Pociask presented a 2007 study done by his organization with funding by a telemarketing research company. An official expressed concern that the presentation was not clear, and asked if page count is based on certain fills levels or declaring the weight on the cartridge itself. Mr. Pociask responded that Quality Logic uses the ISO standards. He concluded that net weight is easy to enforce. Mr. Pociask stressed that his focus is to provide information that gives consumers useful information in purchasing printers and the life cost of the printer, including printer ink cost.

Another official stated that the study was interesting but would like to hear from manufacturers. There are several issues; cartridges are only for specific printers, when comparing price per page you suggest that price is static, and printer ink cartridge refillers need to be addressed.

Mr. Rosenberg (Information Technology Industry Council) agreed that providing consumers with information is meaningful; however, relevant to the consumer is the number of pages that can print. The ISO standards are a good tool, but will lead to customer confusion. Mr. Rosenberg said that much more discussion is necessary on this issue (refer to the *Report of the 96th National Conference on Weights and Measures* [SP 1125, 2011], Appendix C).

2010 NCWM Annual Meeting: The Board of Directors established a Printer Ink and Toner Cartridge Task Group to review and obtain additional information from all stakeholders. Ms. Dempsey (Montgomery County Weights and Measures, Ohio) was appointed as chair and Ms. Warfield was designated as the NIST Technical Advisor.

2010 CWMA Interim Meeting: Ms. Dempsey, Chair, Printer Ink and Toner Cartridge Task Group announced her resignation to the association. Ms. Dempsey gave a briefing on this issue, in particular whether this particular form of ink is included in the exemption of the FPLA. It was indicated that Federal Trade Commission (FTC) believes this exemption only applies to ink in pens, not in printer cartridges. Regulators commented that "yield" is more important for cost comparison for consumers; however, other regulators believed that "yield" is not a weights and measures issue. Another concern was that the ISO yields are based upon approximations. Discussion also included whether regulators would have to purchase printers in order to verify yield. It was generally agreed that this is a very complicated matter, and the method of sale needs to be measurable. An official said he asked a manufacturer how the packages are filled. The response indicated that packages are filled by volume. The CWMA Committee supported the efforts of the Printer Ink and Toner Cartridge Task Group to gather more information for development of this proposal. CWMA recommended that the item remain as an Informational Item.

2010 WWMA Annual Meeting and the 2010 NEWMA Interim Meeting: It was announced that NCWM is seeking a chair for the Printer Ink and Toner Cartridge Task Group. WWMA recommended that the item remain as an Information Item.

2010 SWMA Annual Meeting: It was announced that a chair is needed for the Printer Ink and Toner Cartridge Task Group. The Committee did not endorse the formation of the Printer Ink and Toner Cartridge Task Group to resolve this issue. Only within the past couple years have manufacturers changed their declaration statement to read “yield.” Allowing the declaration by yield will open the door for other commodities to change their labeling (e.g., loads of laundry). The SWMA Committee recommended that these commodities be sold by volume and weight; however, they are not opposed to yield being a supplementary statement. This will allow for inspectors to verify the net contents, and also provide information for consumers to make value comparisons. The Committee would like to seek additional information from industry and ink refillers. SWMA recommended that the item be a Voting Item.

2011 NCWM Interim Meeting: The Printer Ink and Toner Cartridge Task Group held its first work session, chaired by Ms. Maureen Henzler (Kansas Department of Agriculture). There was discussion on the current forms and types of printer ink. Industry also explained that they are able to deliver less ink with a better print quality. As a result they refrain from using the net content statement but believe that a page yield is more useful information for a consumer in making comparisons. Industry was informed that yield is not acceptable and they cannot use words like “approximate” and “estimated.” It was agreed that yield could be a supplementary statement on the package. The 2011 L&R Committee designated this item as an Informational Item.

The Printer Ink and Toner Cartridge Task Group requested the following additional information from industry:

1. How does the ISO standard work and how does this standard would fit into the weights and measures test procedure?
2. How is print darkness measured?
3. Why have manufacturers removed the net weight declaration from packages and replaced it with a page yield?
4. When changing formulas, is the toner receptacle resubmitted back through the ISO standards to validate the page print accuracy?

2011 NEWMA Annual Meeting: There were no comments heard on this item. The Committee Chair reminded members that the Printer Ink and Toner Cartridge Task Group will be meeting on the Sunday prior to the start of the NCWM Annual Meeting, and that industry will be giving a presentation. The NEWMA L&R Committee recommended that this item move forward as an Informational Item.

2011 CWMA Annual Meeting: There were several comments heard on this item. Concern was expressed that ink cartridges used to have quantity on the label, but now, in the marketplace, only yield is used for labeling. A state director expressed concern that ink refillers are not being addressed under this proposal. The CWMA L&R Committee recommended that this item move forward as an Informational Item.

2011 NCWM Annual Meeting: The Printer Ink and Toner Cartridge Task Group held a Sunday work session. Several state, county, and city weights and measures officials and members of industry attended. Mr. Josh Rosenberg (Information Technology Industry Council [ITI]), and other printer industry representatives gave a presentation outlining why they believe yield is the appropriate method of sale for their products. They responded to questions regarding the quantity control they have when manufacturing the cartridges. All industry representatives acknowledged in response to questions that their companies have very good quantity control systems in place for filling cartridges. A stakeholder stated that packages must have the weight, measure, or count; no other type of labeling is acceptable. Participants commented that “yield” is not an acceptable means of labeling for any product. The Printer Ink and Toner Cartridge Task Group agreed to meet again at the 2012 NCWM Interim Meeting. The group requested that industry representatives make another presentation at that time that would be limited just to the labeling issue. The Printer Ink and Toner Cartridge Task Group plans to submit a method of sale proposal to the NCWM L&R Committee for a method of sale for packaged printer ink and toner cartridges.

During the Committee open hearings, Mr. Rosenberg (representing Lexmark, HP, Kodak, Epson and Brother), submitted the industry presentation from the Sunday session for the record (refer to Appendix C in the *Report of the*

96th National Conference on Weights and Measures [SP 1125, 2011]). Mr. Rosenberg remarked that quantity declarations by volume or weight do not meet the objectives of his organization nor consumers' preference. He said that yield is the best way to enable consumers to make informed purchase decisions. He believes the ISO standard for yield can be applied to create that data. Mr. Rosenberg stated that industry representatives will attend upcoming regional meetings to address any issues or concerns. A stakeholder noted that he does not believe the ISO yield standard is acceptable, because each manufacturer's default system is different. He also pointed out that NCWM is not a performance based evaluation agency, and encouraged the Task Group to propose the use of weight or volume as the method of sale. The L&R Committee requested that the Printer Ink and Toner Cartridge Task Group continue developing this item.

2011 CWMA Interim Meeting: An official supported the item and asked the Committee to forward it as a Voting Item. Two other officials would rather see a weight statement because the amount of ink would be too small to measure the density. An official opposing a weight statement and supporting measuring by yield stated that one cannot measure when the cartridge retains some portion of ink and measuring by volume does not help inform the consumer. An official questioned how yield could be measured. Several officials stated that yield could be a supplemental declaration and lawsuits could deal with issues related to yield. NCWM may want to consider having the products labeled by weight and not volume. In addition, supplemental information such as yield may be displayed, but not in the net weight area. CWMA recommended that the item remain as an Informational Item.

2011 WWMA Annual Meeting: A consumer stated that no comments have been heard and, therefore, the item is ready to move forward for a vote. An official did not believe that this item was ready to move forward as a Voting Item because of the lack of testing procedure and a recommendation from the Printer Ink and Toner Cartridge Task Group. He then made a motion that this item be made Informational; this motion did not receive a second motion. In a split vote WWMA recommended that the item be a Voting Item.

2011 NEWMA Interim Meeting: No comments were recorded. NEWMA recommended that the item remain as an Informational Item.

2011 SWMA Annual Meeting: No comments were recorded. The Committee supported the item as written. SWMA recommended that the item be a Voting Item.

2012 NCWM Interim Meeting: Ms. Henzler informed the Committee that the Task Group did not have a recommendation on a method of sale for either the ink or toner. They did suggest minor editorial changes to add the word "copying" after the word "printing" or vice versa, throughout the definitions.

Several members of the ink and toner industry recommended that this item be Withdrawn and they have reflected this in letters written to the Committee since this item first appeared. They remarked that the current proposal would confuse and mislead consumers. They believe that consumers are not concerned with the net quantity of ink they are getting, but how many pages they can print. They agreed that the definitions do need additional work. They added that there are other ink technologies in the marketplace such as, wax sticks and oils. Currently wax sticks/crayons are sold by count.

A contractor commented that the Method of Sale Regulation states that items must be sold on the basis of weight, measure, or count. The regulation should be the starting point with the possibility of adding supplementary information. An industry representative commented that they had submitted previous background and documentation on this item. They will continue to work with the Printer Ink and Toner Cartridge Gravimetric Package Testing Task Group.

The Committee believes test procedures need to be developed to test these commodities. In addition, destructive testing of these products can be costly. The Committee wants to look at the possibility for both toner and ink to be sold by weight. Ms. Cardin will request that the NCWM Board of Directors appoint a new work group to develop test procedures and to disband the current Task Group on Printer Ink and Toner Cartridges. The 2012 L&R Committee designated this item as an Informational Item.

2012 NEWMA Annual Meeting: Mr. Floren (Los Angeles County, California) indicated that there is an impasse on Method of Sale and test procedures on these items. The work group is not planning to meet at this time to resolve the issues. NEWMA recommended that the item remain as an Informational Item.

2012 CWMA Annual Meeting: Ms. Cardin gave an overview of this item and provided an update. The Task Group has been formed to focus on test procedures for weight statements on ink and toner cartridges. An industry representative remarked he was supportive of the Task Group's efforts and that an acceptable method of sale would be reached. He also recommended that the Conference get further participation from industry and stakeholders. The Committee recommends that this item be Information.

2012 NCWM Annual Meeting: The new Printer Ink and Toner Cartridge Gravimetric Package Testing Task Group met to discuss a test method that would require industry to label cartridges with a tare (packaged materials) weight. This Task Group, chaired by Ms. Cardin, will continue developing gravimetric test methods for printer ink and toner cartridges, and will provide a report at the 2013 NCWM Interim Meeting. The Committee is placing an item in the 260 Series (NIST Handbook 133) of the next agenda to report the work of the Printer Ink and Toner Cartridge Gravimetric Package Testing Task Group. The L&R Committee will delay further development of this Method of Sale item until the Task Group has completed its recommendations.

2012 CWMA Interim Meeting: The NCWM L&R Committee from the CWMA reported that the Printer Ink and Toner Cartridge Gravimetric Package Testing Task Group is developing test methods for printer ink and toner. CWMA is neutral and recommended that the item remain as an Informational Item.

2012 WWMA Annual Meeting: The Committee noted that the NCWM L&R Committee will not develop this item further until it receives recommendations for gravimetric testing from the Printer Ink and Toner Cartridge Gravimetric Package Testing Task Group. WWMA recommended that the item be Withdrawn.

2012 SWMA Annual Meeting: An industry representative serving on the Printer Ink and Toner Cartridge Gravimetric Package Testing Task Group commented that it is a new group established to develop a test procedure for checking net contents without regard for the method of sale. SWMA supported the Method of Sale proposal as written recommended that the item be a Voting Item.

2012 NEWMA Interim Meeting: NEWMA recommended that the item be an Informational Item.

2013 NCWM Interim Meeting: Judy Cardin (Printer Ink and Toner Cartridge Gravimetric Package Testing Task Group Chair) provided a presentation on the work of the task group (refer to Item 260-3). Ms. Cardin also provided a marketplace survey that reflected "count" was the most common quantity statement being used. Industry was asked about the feasibility of placing the tare weight on cartridges. Their response was that it was not practicable due to cartridge parts being manufactured domestically and internationally and may not always be made of the same material. The presentation also reflected an in-house test using a gravimetric procedure. The Task Group concluded that there is not a practical test procedure and the work group is disbanding. The Committee discussed the results of the task group and reviewed the method of sale language. In conclusion the method of sale language was revised by the L&R Committee to allow for this product to be sold by count. Ms. Lisa Warfield (NIST, OWM) commented that consideration needs to be given to the time manufacturers will need to change over their labeling. The L&R Committee recommended this as a Voting Item.

NEWMA had several representatives that believed "count" was meaningless. A remark was made about "low count" being exempt from count requirements. NIST responded that it would be exempt if written into the requirements. The Federal Trade Commission (FTC) was consulted but did not take a position on the issue. Several attendees speaking as consumers voiced concerns on a yield statement. NIST advised that there are ISO/IEC yield standards. NEWMA recommends the modification to Section XX.2. Method of Sale.

2.XX.2. Method of Sale and Labeling.

2.XX.2.1. Method of sale, printer ink cartridges. – All printer ink cartridges kept, offered, or exposed for sale or sold shall be sold in terms of the count

2.XX.2.2. Method of Sale, toner cartridges. – All toner cartridges kept, offered, or exposed for sale or sold shall be sold in terms of the count

2.XX.3. Yield Disclosure. – **The seller shall disclose the yield of printer ink or toner cartridges as per ISO/IEC 19752, ISO/IEC 19798, ISO/IEC 24711, ISO/IEC 24712 on the package offered for prepackaged sale, or on the receipt for direct sale, or on the transfer document for bulk sale.**

All work has been completed and industry and NCWM L&R are in agreement on the Method of Sale by Count. The proposed modification provides clarity to the consumer when “yield” is questioned. NEWMA recommends the modified language move forward as a Voting Item.

CWMA reviewed the modified language from NEWMA and agrees that count alone is not sufficient and that yield should be considered since it appears to be the best option and solution. It was agreed that weight is the correct solution if a test method could be determined. CWMA recommends that a yield be required and disclosed on the principal display panel of the package, on the receipt for direct sale, or on the transfer document for bulk sale. CWMA recommends with these changes it be a Voting Item.

During the 2013 NCWM Annual Meeting the Committee heard several comments that there may not be a feasible way to label and test this product. Industry believes that consumers are interested in a yield statement when making a purchase. The Committee modified the language in Section 2.XX.3. Yield Disclosure to read as:

2.XX.3. Yield Disclosure. – **If the seller discloses the yield of printer ink or toner cartridges on the package, then it shall be measured using the latest version of ISO/IEC printer yield standard on the package offered for prepackaged sale. This information shall be considered a supplemental statement.**

The Committee moved this item to an Informational for a review of the amended language at the Fall Regional Association Meetings.

Additional letters, presentations, and data may have been part of the Committee’s consideration. Please refer to Appendix C in the *Report of the 97th National Conference on Weights and Measures* (SP 1160, 2012) to review these documents.

232-5 V Section 2.XX. Retail Sale of Electricity/Vehicle

(This item was adopted.)

Source:

National Institute of Standards and Technology, Office of Weights and Measures (2012)

Purpose:

Create a Developing Item to engage the weights and measures community in creating a method of sale to support uniformity in retail sales of electricity as vehicle fuel.

Item Under Consideration:

2.XX. Retail Sales of Electricity Sold as a Vehicle Fuel.

2.XX.1. Definitions.

2.XX.1.1. Electricity sold as vehicle fuel. – **Electrical energy transferred to and/or stored onboard an electric vehicle primarily for the purpose of propulsion.**

2.XX.1.2. Electric vehicle supply equipment (EVSE). – **The conductors, including the ungrounded, grounded, and equipment grounding conductors; the electric vehicle connectors; attachment plugs;**

and all other fittings, devices, power outlets, or apparatuses installed specifically for the purpose of measuring, delivering, and computing the price of electrical energy delivered to the electric vehicle.

2.XX.1.3. Fixed service. – Service that continuously provides the nominal power that is possible with the equipment as it is installed

2.XX.1.4. Variable service. – Service that may be controlled resulting in periods of reduced, and/or interrupted transfer of electrical energy.

2.XX.1.5. Nominal Power. – Refers to the “intended” or “named” or “stated” as opposed to “actual” rate of transfer of electrical energy (i.e., power).

2.XX.2. Method of Retail Sale. – All electrical energy kept, offered, or exposed for sale and sold at retail as a vehicle fuel shall be in units in terms of the megajoule (MJ) or kilowatt-hour (kWh). In addition to the fee assessed for the quantity of electrical energy sold, fees may be assessed for other services; such fees may be based on time measurement and/or a fixed fee.

2.XX.3. Retail Electric Vehicle Supply Equipment (EVSE) Labeling.

(a) A computing EVSE shall display the unit price in whole cents (e.g., \$0.12) or tenths of one cent (e.g., \$0.119) on the basis of price per megajoule (MJ) or kilowatt-hour (kWh). In cases where the electrical energy is unlimited or free of charge, this fact shall be clearly indicated in place of the unit price.

(b) For fixed service applications, the following information shall be conspicuously displayed or posted on the face of the device:

- (1) the level of EV Service expressed as the nominal power transfer (i.e., nominal rate of electrical energy transfer), and**
- (2) the type of electrical energy transfer (e.g., AC, DC, wireless).**

(c) For variable service applications, the following information shall be conspicuously displayed or posted on the face of the device:

- (1) the type of service (i.e., “Variable”);**
- (2) the minimum and maximum power transfer that can occur during a transaction, including whether service can be reduced to zero;**
- (3) the conditions under which variations in electrical energy transfer will occur; and**
- (4) the type of electrical energy transfer (e.g., AC, DC, wireless).**

(d) Where fees will be assessed for other services in direct connection with the fueling of the vehicle, such as fees based on time measurement and/or a fixed fee, the additional fees shall be displayed.

(e) The EVSE shall be labeled in accordance with 16 CFR, PART 309 – FTC Labeling Requirements for Alternative Fuels and Alternative Fueled Vehicles.

(f) The EVSE shall be listed and labeled in accordance with the National Electric Code® (NEC) NFPA 70, Article 625 Electric Vehicle Charging Systems (www.nfpa.org).

2.XX.4. Street Sign Prices and Other Advertisements.

Where electrical energy unit price information is presented on street signs or in advertising other than on the EVSE:

- (a) The electrical energy unit price shall be in terms of price per megajoule (MJ) or kilowatt-hour (kWh) in whole cents (e.g., \$0.12) or tenths of one cent (e.g., \$0.119). In cases where the electrical energy is unlimited or free of charge, this fact shall be clearly indicated in place of the unit price.**
- (b) In cases where more than one electrical energy unit price may apply over the duration of a single transaction to sales to the general public, the terms and conditions that will determine each unit price and when each unit price will apply shall be clearly displayed.**
- (c) For fixed service applications, the following information shall be conspicuously displayed or posted:**
 - (1) the level of EV Service expressed as the nominal power transfer (i.e., nominal rate of electrical energy transfer), and**
 - (2) the type of electrical energy transfer (e.g., AC, DC, wireless).**
- (d) For variable service applications, the following information shall be conspicuously displayed or posted:**
 - (1) the type of delivery (i.e., “Variable”);**
 - (2) the minimum and maximum power transfer that can occur during a transaction, including whether service can be reduced to zero;**
 - (3) the conditions under which variations in electrical energy transfer will occur; and**
 - (4) the type of electrical energy transfer (e.g., AC, DC, wireless).**

Where fees will be assessed for other services in direct connection with the fueling of the vehicle, such as fees based on time measurement and/or a fixed fee, the additional fees shall be included on all street signs or other advertising.

(Added 2013)

Background/Discussion:

Significant work is needed to gather and incorporate all available input from stakeholders including device manufacturers, public utility commissions, weights and measures officials, smart grid experts, and all others that are in a position to contribute to the development of a method of sale for electricity as vehicle fuel. Thus, it is recommended that this item be taken up as a Developing Item to encourage input from stakeholders and experts in the development of proposed definitions, method of sale requirements, retail equipment price posting and labeling requirements, and any other elements needed to advance the item for adoption.

While a specific proposal for consideration has yet to be developed, some preliminary examples and points to consider are offered below:

2.XX.1. Definitions.

- (a) Electric Vehicle or Hybrid-Electric Vehicle.** – A vehicle that employs electrical energy as a primary or secondary mode of propulsion.
- (b) Plug-in Electric Vehicle (PEV).** – An electric vehicle that has onboard electrical energy storage designed to be charged via a physical connection to an external source of electrical energy.
- (c) Electricity as Vehicle Fuel.** – Electrical energy transferred to and/or stored onboard an electric vehicle primarily for the purpose of propulsion.

(d) Electric Vehicle Supply Equipment (EVSE). – A device or system used to transfer electrical energy to an electric vehicle, either as charge transferred via physical or wireless connection, by loading a fully charged battery, or by other means.

2.XX.2. Method of Retail Sale and Supply Equipment Labeling. – Preliminary review suggests that the method of sale should be based on metered quantities to facilitate value comparison by consumers. The units should be specified for all electrical energy kept, offered, or exposed for sale and sold at retail as vehicle fuel, such as electrical energy units in terms of kilowatt hours (kWh) and/or in the metric equivalent unit for electrical energy Joules (J).

2.XX.3. Retail Service Equipment Labeling. – The unit price on the basis of the method of sale will be important to consumers as a basis for a value comparison regardless of whether the electrical energy is delivered through a slow plug-in charging device, a fast charging device, or by battery replacement.

2.XX.4. Presentation of Price (Street Signs and Advertisements). – The unit price according to method of sale will be important to clearly represent on street signs and advertisements when a consumer must make a value comparison before pulling their vehicle into a station to purchase electrical energy.

Although many Plug-in Electric Vehicle (PEVs) are primarily charged in homes and at work, it is projected that there will be a growing need for public PEV charging stations in order to address public expectations and allow for successful adoption of PEV technology by the public. Several states have observed emergence of PEVs and made inquiries regarding direction of NCWM toward a method of sale for electricity as a vehicle fuel. One online resource for locating charging stations at https://na.chargepoint.com/charge_point identifies nearly 1100 charging stations already deployed across the United States. Use of electric vehicles and hybrid-electric vehicles is increasing. Adoption of electric vehicles is being driven by a number of factors, including high traditional fuel prices, auto industry investment in PEV technology, government investment and subsidies, national fuel economy standards, and state and national zero-emission vehicle and greenhouse gas standards.

A single, consistent method of sale is needed to pave the way for accurate measurement and representation of quantities sold and to facilitate value comparison by consumers. The method of sale is a crucial element that must be in place before the suitability of measurement methods and device technologies can be assessed. A measurement that is accurate, consistent, and understandable will promote consumer confidence and will provide consumers with a fundamental tool to perform value comparisons and protect themselves from confusion and fraud. An electrical energy-based method of sale would accomplish this.

Other methods of publicly offering electrical energy for sale as vehicle fuel have appeared in the absence of a nationally standardized method of sale. These include time-based charges, subscriber access, and gratis (free of charge) access. The coexistence of multiple methods of sale for the same commodity frustrates consumers' efforts to make informed value comparisons.

The actual value to a motorist of the electrical energy that is received during charging is in terms of the distance that they are able to travel. The increase in the distance traveled after receiving a charge is dependent on the amount of electrical energy that was delivered during the charging event. The amount of charge the vehicle receives during a charging event cannot be determined solely by measuring the time it was connected to the charging system. The rate per time the charge is delivered will depend on many factors that cannot be controlled including, but not limited to, the starting charge level, the design of the vehicle battery, the type of charging equipment, and other environmental variables. For these reasons, a time based method of sale will not form a sound basis for a consistent value comparison and an electrical energy-based method of sale is strongly recommended.

The current equipment for vehicle charging that is available in the marketplace today represents a very wide range of charging speeds, further emphasizing the need for a single method of sale. Level 1 equipment charges vehicles with 110 VAC and can take from 8 hours to 12 hours to fully charge a vehicle. In contrast, a fast DC type of Electric Vehicle Supply Equipment (EVSE) is capable of charging a vehicle from 20 % to 80 % of full charge in 10 minutes, closely approximating the time of a traditional liquid (e.g., gasoline) vehicle fueling cycle. Consumers place a high value on their time; therefore, it is reasonable to expect that the unit price for electrical energy from a device capable of very fast charging will be higher. This can also be anticipated because the equipment capable of

faster charging represents a higher capital investment. Since stations may offer multiple options for charging speed, a uniform language for describing the type of charging equipment available by providers should be developed so that this important aspect of consumer value can be presented consistently in conjunction with the unit price to aid in the value comparison.

Vehicle charging using types of EVSE that offer slower charging rates is often offered in conjunction with other paid services (e.g., parking, valet parking, routine vehicle maintenance). In these cases, the unit price for electrical energy offered should be presented separately from any price for the other paid service(s) to allow for a value comparison with the cost of electrical energy offered by other providers.

For reference, a typical PEV can hold a charge of 24 kWh in onboard storage, with some vehicles capable of holding as high as 75 kWh. The average price of electrical energy in the United States is \$0.075 per kWh and the average price for residential electrical energy is \$0.089 per kWh. Presuming that the price for electrical energy as a vehicle fuel might range from \$0.10 kWh to \$0.50 per kWh (perhaps depending on the speed of the ESVE charger), then the cost to the consumer to fill a vehicle might range from \$2.40 to as high as \$37.50.

An additional issue that needs to be explored and developed is that of “battery exchanges.” Equipment already exists that allows consumers to swap a depleted storage device for a fully charged onboard storage device (i.e., battery). In this case, the amount of charge present in the fully charged device should be communicated to the consumer consistent with the method of sale to enable a value comparison between this method and plug-in ESVE charging. The issue of whether and how to credit a consumer for the amount of charge that exists in the battery that is to be removed should be considered as this item develops.

There are currently as many as eight manufacturers of EVSE that would benefit from clear direction on method of sale and device standards.

The National Association of Regulatory Utility Commissioners (NARUC) and other local Public Utility Commissions (PUC) interests have identified PEV use, and particularly public re-charging use cases, as having potentially significant impact on Public Utility efficiency, infrastructure needs, and pricing structures. Collaboration with these organizations in the development of national legal metrology standards for electrical energy sold as vehicle fuel would offer an opportunity for the creation and implementation of standards that take into consideration the missions of both NARUC and NCWM.

There is a likelihood that stations owned and operated by public utilities will coexist with privately owned charging stations. There may be regulatory issues in some jurisdictions that effect price regulation and competitiveness between these two types of stations. This is another reason that NARUC and PUC input is critically needed on development of a method of sale.

In *Comments of the Division of Ratepayer Advocates to the California PUC* (see Section II.A www.dra.ca.gov/NR/rdonlyres/B2E02349-740A-4EA8-A4D0-69ED3C0D6623/0/R0908009DRACOMMENTS_A1b.pdf), the question has also been raised as to whether PUCs may require residential customers to install a separate electric sub-meter for PEV charging. If this occurs, it is most likely that consumers would be invoiced for charging their vehicles at home in the same kWh units that are used for their primary billing. If the method of sale at public charging stations matches the units that are billed for charging the same vehicle at the residence, this will further facilitate the value comparison by consumers.

In some states, electrical energy sub-metering already falls under the jurisdiction of state and local weights and measures authorities. These jurisdictions must now use established standards other than NIST Handbook 44 and NIST Handbook 130. National standards for the sale of electrical energy in NIST Handbook 44 and NIST Handbook 130 would promote greater uniformity on sub-metering applications.

2011 CWMA Interim Meeting: An official suggested referencing FTC for labeling on alternative fuels. CWMA did not forward the item to NCWM and recommended returning the item to the submitter for development.

2011 WWMA Annual Meeting: An official commented that such vehicles already exist and there is no need for this matter to be addressed by NCWM. The Committee acknowledged that new technology is in the marketplace and encouraged NCWM to develop a method of sale for electricity as a vehicle fuel. WWMA forwarded the item to NCWM, recommending it as a Developing Item.

2011 NEWMA Interim Meeting: An official questioned how consumers will be charged, how the effort will be monitored, and whether this would be considered a regulated utility. NEWMA forwarded the item to NCWM, recommending it as a Developing Item.

2011 SWMA Annual Meeting: An official asked for clarification regarding the definition of an electric or hybrid electric vehicle. A NIST Technical Advisor noted that there is an absence of a clearly defined method of sale. Inquiries regarding the correct method of sale have increased as growth in charging stations have grown. The Technical Advisor asked that this item be made Developing because much information needs to be gathered. A couple of officials responded that only their utility companies can sell electricity. It was recognized that public utilities need to be an integral part of the process. An official questioned whether a measuring device for electricity exists today, and whether it was National Type Evaluation Program certified. There was also a question as to whether a test measure can be traceable and certifiable to a standard. An official expressed support for this item. SWMA forwarded the item to NCWM recommending it as a Developing Item.

2012 NCWM Interim Meeting: Concern was expressed with the definitions for primary and secondary and that the item only deals with vehicle fuel. At this time, there is no proposal under consideration, and the language under the area "background/discussion" is to be considered. The NIST Technical Advisor remarked that NIST, OWM is gathering data and information from many resources. Eventually a work group will be formed to further develop this item. The Committee designated this item as a Developing Item.

2012 NEWMA Annual Meeting: A n attendee commented that these devices are not utility meters; they are subsidiary meters that fall under weights and measures authority. Another attendee voiced support as a developing item because businesses are installing these sub-meters and a uniform method of sale is needed. NE WMA recommended that the item remain as a Developing Item.

2012 CWMA Annual Meeting: A regulatory official remarked that this is not a public utility and owners of these charging units make free market sales. States should be concerned that this is a rapidly growing market without any standard. Other states commented; one stating that charging stations are selling by time, not kilowatt hour and the other stating that the charging stations are a free service for now. A regulatory official remarked that there are quick and slow charging stations and recommended that consumers be charged on what the vehicle is capable of receiving rather than what the device is capable of delivering. CWMA recommended that the item remain as a Developing Item.

2012 NCWM Annual Meeting: NIST, OWM announced that a NIST work group has been formed to develop this item and there are two meetings schedule over the next several months. A preliminary draft code has been developed, which closely follows the California standard. Two regulatory officials expressed urgency in developing this proposal.

2012 WWMA Annual Meeting: Ms. Kristin Macey (California) supported the item, stating that regulations would provide clear authority in the marketplace. Ms. Macey also reminded the states to look at their signage laws to see if there is an impact. Ms. Juana Williams, NIST Technical Advisor and Chair of the Electric Vehicle Fueling and Submetering (EVF&S) Work Group (WG) reported that they held their first web-based meeting on August 29, 2012. They covered the structure and goals of the WG and membership status (active or observer) of each attendee was established. The next meeting will be held in person at NIST in Gaithersburg, Maryland, with an option to attend via webinar at a date to be determined in December 2012 or January 2013. The group will discuss technical issues for the first time at this next meeting. NIST has provided the work group with draft proposals for a new Handbook 44 code and a draft NIST Handbook 130 method of sale. The draft code will be starting points as the group fully develops these two items. WWMA recommended that the item remain as a Developing Item.

2012 SWMA Annual Meeting: SWMA recommended that the item be an Informational Item.

2012 NEWMA Interim Meeting: NEWMA members again expressed urgency for a final product on the topic. This should be given a higher priority by the WG as more charging stations are appearing without specific guidance on method of sale placing the consumer at a disadvantage.

2013 NCWM Interim Meeting: Ms. Williams provided the Committee with a status report and the latest language for consideration of the findings of the WG. Ms. Williams also remarked that the WG would like to see this item move forward as a Voting Item. Several states voiced support for this item and encouraged regulators to be active with this WG. The L&R Committee is recommending this move forward as a Voting Item. The CWMA and NEWMA agree that this item clarifies the Method of Sale for Retail Sale. This will allow the S&T Committee to work with stakeholders and regulators to develop test procedures.

2013 NCWM Annual Meeting: EVFS Chair, Ms. Williams gave a briefing on the status of the EVF&S WG meeting held at NIST in Gaithersburg, Maryland, on June 11, 2013. Mr. Jim Creevy (NEMA) and a member of the EVF&S WG submitted language that was developed by the WG on June 11, 2013, (refer to Appendix D in this report, *Report of the 98th National Conference on Weights and Measures* [2013]). However, there was no consensus between industry and regulators on this specific language. The Committee proposed the language under the Item Under Consideration move forward as a Voting Item.

If you are interested in assisting with the development of this item please contact, Ms. Juana Williams (NIST, OWM), Chairperson for the Electric Vehicle Fueling and Submetering Work Group at (301) 975-3989 or juana.williams@nist.gov.

232-6 I Section 2.30. ~~E85 Fuel Ethanol Flex Fuel Blends~~

Source:

Fuels and Lubricants Subcommittee Task Group (2012)

Purpose:

Update regulations related to flex fuels.

Item Under Consideration:

Uniform Regulation for the Method of Sale of Commodities

2.30. ~~E85 Fuel Ethanol Flex Fuel Blends.~~

2.30.1. ~~How to Identify Fuel Ethanol Flex Fuel Blends.~~ – ~~Fuel Ethanol Flex Fuel Blends~~ shall be identified as Ethanol Flex Fuel or EXX Flex Fuel ~~E85~~.

2.30.2. Labeling Requirements.

(a) ~~Ethanol Flex Fuel blends with an ethanol concentration no less than 51 and no greater than 83 volume percent shall be labeled “Ethanol Flex Fuel, minimum 51 % ethanol”. Fuel ethanol shall be labeled with its automotive fuel rating in accordance with 16 Code of Federal Regulations Part 306.~~

(b) ~~Ethanol Flex Fuel blends with an ethanol concentration less than or equal to 50 volume percent shall be labeled “EXX Flex Fuel, minimum YY % ethanol”, where the XX is the target ethanol concentration in volume percent and YY is XX minus 5. The actual ethanol concentration of the blend shall be XX volume percent plus or minus 5 volume percent.~~

(c)(b) A label shall be posted which states “For Use in Flexible Fuel Vehicles (FFV) Only.” This information shall be clearly and conspicuously posed on the upper 50 % of the dispenser front panel in a type at least 12.7 mm (½ in) in height, 1.5 mm (1/16 in) stroke (width of type). A label shall be posted which

states, **“CHECK OWNER’S MANUAL”, in 20 point font “Consult Vehicle Manufacturer Fuel Recommendations,” and shall not be less than 6 mm (¼ in) in height by 0.8 mm (1/32 in) stroke; block style letters** and the color shall be in definite contrast to the background color to which it is applied.

(Added 2007) (Amended 20XX)

Background/Discussion:

The current wording in NIST Handbook 130 related to fuels restricted to use in Flex Fuel Vehicles should be reviewed. Input gathered from the regional meetings and other stakeholders will be used by FALS to develop recommended modifications to NIST Handbook 130.

2013 NCWM Annual Meeting: Mr. Chuck Corr, Chair of the task group under FALS provided initial language changes for a Section 2.30. ~~E85 Fuel~~ Ethanol Flex Fuel Blends. There is additional work being done by this task group under the L&R Committee Item 237-9.

237 NIST HANDBOOK 130 – UNIFORM ENGINE FUELS AND AUTOMOTIVE LUBRICANTS REGULATION

237-1 I Section 1. Definitions – Diesel Liter Equivalent (DLE) and Diesel Gallon Equivalent (DGE)

Source:

Clean Vehicle Education Foundation (2013)

Purpose:

Enable consumers to make cost and fuel economy comparisons between diesel fuel and natural gas.

Item Under Consideration:

Amend NIST Handbook 130, Engine Fuels and Automotive Lubricants Regulation as follows.

Section 1. Definitions

1.XX. Diesel Liter Equivalent (DLE). – means 0.756 kg of natural gas.

(Added 20XX)

1.XX. Diesel Gallon Equivalent (DGE). – means 2.863 kg (6.312 lb) of natural gas.

(Added 20XX)

Background/Discussion:

The gasoline gallon equivalent (GGE) unit was defined by NIST/NCWM in 1994 (refer to Appendix B in this report, *Report of the 98th National Conference on Weights and Measures* [2013]) to allow users of natural gas vehicles to readily compare costs and fuel economy of light-duty natural gas vehicles with equivalent gasoline powered vehicles. For the medium and heavy duty natural gas vehicles in widespread use today, there is a need to officially define a unit (already in widespread use) allowing a comparison of cost and fuel economy with diesel powered vehicles. Also, natural gas is sold as a vehicle fuel as either Compressed Natural Gas (CNG) or Liquefied Natural Gas (LNG) and each method of sale in measure in mass. Therefore, the generic term for natural gas is proposed to be used in NIST Handbooks 44 and 130 without the existing term "compressed." The mathematics justifying the specific quantity (mass) of natural gas in a DLE and DGE is included in Appendix B of this report (*Report of the 98th National Conference on Weights and Measures* [2013]).

The official definition of a DLE and a DGE will likely provide justification for California, Wisconsin, and any other state to permit retail sales of LNG for heavy-duty vehicles in these convenient units.

2012 CWMA Interim Meeting: A regulatory official commented that there is no standard for Diesel Gallon Equivalent (DGE), and LNG and CNG are being sold in Wisconsin and other states as DGE in order to compete with diesel sales. As a result, a standard is urgently needed. DGE sales are occurring in the marketplace without a standard. The Committee recommended that FALS review the conversion factors for DGE and LGE for accuracy. CWMA supported this item and forwarded the item to NCWM, recommending it as a Voting Item.

2012 WWMA Annual Meeting: The Committee worked in tandem with the S&T Committee since it had a related item. Ms. Kristin Macey (California) opposed the item because it would cause complications in the marketplace. The Committee believed the item had merit but would like to know whether the values accurately represent the actual value of various types of natural gas products. It acknowledged there are different compositions and sources; for example, LNG has a higher methane composition. Is there also a possibility of additional conversion factors based on BTUs from different sources? The Committee requested outreach by NCWM to other stakeholders to get their involvement on these items. WWMA forwarded the item to NCWM recommending it as an Informational Item.

2012 SWMA Annual Meeting: SWMA recommends review by the Fuels and Lubricants Subcommittee and forwarded the item to NCWM recommending it as an Informational Item.

2012 NEWMA Interim Meeting: NEWMA reviewed the CWMA comments. A General Motors representative indicated that there is a lot of discussion on a point of reference. There was comment that both methods of labeling may be required on a dispenser. The labeling issue may create more confusion for the consumer. NEWMA recommended review by the Fuels and Lubricants Subcommittee (FALS). NEWMA forwarded the item to NCWM recommending it as an Informational Item.

2013 NCWM Interim Meeting: A presentation in support of this item was given by Mr. Doug Horne (Clean Vehicle Education Foundation). Several comments were heard regarding the references and databases used to develop the calculations. Concern was expressed with the conversion factors used. A NIST S&T Technical Advisor recommends that L&R and S&T Committees work in a joint session since there is a companion Item 337-1 on the S&T agenda. A collaborative effort between the L&R and S&T Committees will ensure that the proposed equivalent unit is dispensed accurately at the dispenser. Several attendees spoke in support of the collaborative effort. The Committee will request the NCWM Board of Directors create a steering committee that consists of experts and stakeholders to review this proposal. L&R Committee will prepare a list of comments that they would like the Steering Committee to review and address. The L&R Committee recommends this as Informational Item.

2013 NCWM Annual Meeting: The Committee was informed the Natural Gas Steering Committee chaired by Mr. Mahesh Albuquerque would be reviewing this item.

Refer to Appendix B in this report (*Report of the 98th National Conference on Weights and Measures [2013]*) for additional letters, presentations, and data that were part of the Committee's consideration.

Additional Contacts: Clean Energy, Seal Beach, California, NGVAmerica, Washington, DC, Clean Vehicle Education Foundation, Acworth, Georgia

237-2 I Sections 2.1.3. Minimum Antiknock Index (AKI), Section 2.1.4. Minimum Motor Octane Number, and Section 3.2.5. Prohibition of Terms – Table 1.

Source:

General Motors (2013)

Purpose:

Remove obsolete Altitude De-rating of Octane practice, establish a National Octane Baseline, and harmonize Octane Labeling from state to state.

Item Under Consideration:

Amend the NIST Handbook 130, Engine Fuels and Automotive Lubricants Regulation as follows:

2.1.3. Minimum Antiknock Index (AKI). – The AKI of gasoline and gasoline-oxygenate blends shall not be less than 87. The AKI shall not be less than the AKI posted on the product dispenser or as certified on the invoice, bill of lading, shipping paper, or other documentation.

2.1.4. Minimum Motor Octane Number. – The minimum motor octane number shall not be less than 82. ~~for gasoline with an AKI of 87 or greater;~~

3.2.5. Prohibition of Terms – It is prohibited to use specific terms to describe a grade of gasoline or gasoline-oxygenate blend unless it meets the minimum antiknock index requirement shown in Table 1. Minimum Antiknock Index Requirements.

Table 1. Minimum Antiknock Index Requirements		
Term	Minimum Antiknock Index	
	ASTM D4814 Altitude Reduction Areas IV and V	All Other ASTM D4814 Areas
Premium, Super, Supreme, High Test	90	91
Midgrade, Plus	87	89
Regular Leaded	86	88
Regular, Unleaded (alone)	85	87
Economy	--	86

(Table 1. Amended 1997 and 20XX)

Background/Discussion:

These NIST Handbook 130 octane changes will harmonize with an effort underway in the ASTM International (ASTM) Gasoline and Oxygenates Subcommittee to include a minimum motor octane number (MON) performance limit in gasoline. The naming of the various octanes is a function for weights and measures.

Nominally, vehicles manufactured after 1984 include engine computer controls maintaining optimal performance while using gasoline octane of 87 AKI or higher. The practice of altitude de-rating of octane, resulting in octanes below 87 AKI, reduces a vehicle's efficiency and fuel economy. Increasingly, more vehicles are boosted (turbocharged/supercharged) eliminating altitude intake air effects. Additionally, consumers using gasoline with an octane AKI below 87 will void their vehicle owner's warranty. The Coordinating Research Council (CRC) Report No. 660, "*Fuel Anti-knock Quality – Engine Response to RON (Research Octane Number) versus MON,*" May 2011 demonstrates the continued need for gasoline MON octane for the large bored, naturally aspirated U.S. engines. Setting an 82 MON minimum maintains the current MON level for today's 87 AKI Regular Unleaded gasoline. A common U.S. octane specification between ASTM, NCWM, and Vehicle Owners Manuals will give states clear direction on how best to enforce proper fuel pump octane labeling and quality levels on behalf of vehicle consumers.

Leaded gasoline is not available at retail and, therefore, labeling guidance is not needed.

Mr. Bill Studzinski (General Motors) gave a presentation at the 2012 CWMA Interim Meeting. He stated there is no minimum AKI specification in NIST Handbook 130. NCWM wants to align ASTM D4814 with NIST Handbook 130, but there is no minimum in ASTM D4814 and ASTM is looking at this. Less than 1 % of vehicles on the road today are 1984 or prior. All vehicle owner's manuals stipulate 87 octane or higher. Using 85 octane in these vehicles causes slight reductions in efficiency and fuel economy. There should be harmonization between vehicles owner's manuals, NCWM, and ASTM. The minimum AKI should be 87 and the minimum MON should be 82. Minimum octane of 87 is really an ASTM issue. A regulatory official believed that if we adopted this language it would provide the states with appropriate octane levels. The resource for octane is small, but currently OEMs are manufacturing for all vehicles to tolerate this fuel. A Renewable Fuels Association representative commented that state regulators who are with NCWM regulate octane, and NCWM should have the standards and

not wait for ASTM. CWMA supports this item and forwarded the item to NCWM recommending it as a Voting Item. At the 2013 CWMA Annual Meeting, the Committee recommended this remain an Informational Item pending the outcome of the June 2013 ASTM ballot that is related to octane.

Mr. Studzinski provided a presentation at the 2012 WWMA Annual Meeting. The Committee would like to have ASTM and FALS work in tandem to develop a proposal that provides a phase out period. The Committee recommended a modification to the proposal to allow for the Table 1. Minimum Antiknock Index Requirements chart to remain with Section 3.2.5. Prohibition of Terms. WWMA forwarded the item to NCWM recommending it as an Informational Item as modified and presented as follows:

2.1.4. Minimum Antiknock Index (AKI). – **The AKI of gasoline and gasoline-oxygenate blends shall not be less than 87.** The AKI shall not be less than the AKI posted on the product dispenser or as certified on the invoice, bill of lading, shipping paper, or other documentation.

2.1.5. Minimum Motor Octane Number. – The minimum motor octane number shall not be less than ~~82. for gasoline with an AKI of 87 or greater;~~

(Amended 2009 and 20XX)

3.2.5. Prohibition of Terms. – It is prohibited to use specific terms to describe a grade of gasoline or gasoline-oxygenate blend unless it meets the minimum antiknock index requirement shown in Table 1. Minimum Antiknock Index Requirements.

(Amended 20XX)

Table 1. Minimum Antiknock Index Requirements		
Term	Minimum Antiknock Index	
	ASTM D4814 Altitude Reduction Areas IV and V	All Other ASTM D4814 Areas
Premium, Super, Supreme, High Test	90	91
Midgrade, Plus	87	89
Regular Leaded	86	88
Regular, Unleaded (alone)	85	87
Economy	--	86

Table 1. (Amended 1997 and 20XX)

2012 SWMA Annual Meeting: Mr. Bill Studzinski (General Motors), Chair of a FALS Task Group and ASTM provided a presentation supporting this item. The SWMA Committee acknowledged strong support from their Association, and forwarded the item to NCWM recommending it as a Voting Item.

2012 NEWMA Interim Meeting: Mr. Studzinski provided a presentation and summarized the position of the other regions. NEWMA forwarded the item to NCWM recommending it as a Voting Item.

2013 NEWMA's Annual Meeting: It was recommended the item remain Informational until FALS makes a recommendation to the Committee.

2013 NCWM Interim Meeting: FALS could not reach agreement on this item during their Sunday work session. The Committee received and reviewed several letters in support of this proposal. During open hearings Mr. Studzinski provided a presentation. The Committee also received comments in opposition to the proposal citing the lack of consumer complaints with sub-octane, and it was requested that the Committee wait until the CRC study

provides data that can be used by ASTM and NCWM to determine whether or not a change is necessary. The Committee recommends this to be an Informational Item.

2013 NCWM Annual Meeting: Mr. Ron Hayes, FALS Chair, provided a presentation and stated that the CCR study has been expanded and finalized data is expected by year end. It was also noted the ASTM ballot failed. The Committee concurs to await a recommendation from FALS once they have considered all the data.

Refer to Appendix E in this report (*Report of the 98th National Conference on Weights and Measures [2013]*) for additional letters, presentations, and data that were part of the Committee's consideration.

237-3 I Section 2.1.4. Minimum Motor Octane Number

(This item was withdrawn.)

Source:

BP Global Fuels Technology – West Coast (2011)

Purpose:

Remove obsolete language from the regulation.

Item Under Consideration:

Amend the NIST Handbook 130, Engine Fuels and Automotive Lubricants Regulation, Section 2.1.4. Minimum Motor Octane Number as follows:

~~**2.1.4. Minimum Motor Octane Number.**— **The minimum motor octane number shall not be less than 82 for gasoline with an AKI of 87 or greater;**~~

Background/Discussion:

In the early 1990s, the Table titled “Automotive Spark-Ignition Engine Fuel Antiknock Indexes in Current Practice” was removed from the body of ASTM D4814 and placed into an appendix in ASTM D4814. This appendix is non-mandatory information and is not part of the specification. It is inappropriate for NIST Handbook 130 to continue with the 82 motor octane number minimum for the following reasons: 1) 82 motor octane number minimum is not an ASTM D4814 specification; 2) FTC regulates octane posting and has no motor octane number minimum; 3) neither the Kinder Morgan Pipeline nor the Olympic Pipeline requires a minimum motor octane number specification; and 4) the Colonial Pipeline has no motor octane number minimum for either Reformulated Blendstock for Oxygenate Blending or Conventional Blendstock for Oxygenate Blending.

Recent data shows a low motor octane number is actually preferable for the current fleet of vehicles. Motor and Research octane numbers are equally important to the performance of the motor vehicle engine. A minimum motor octane number requirement offers no more protection to the consumer than the road octane number that is the average of the Motor and Research octane numbers.

2010 SWMA and WWMA Annual Meetings and the 2010 CWMA and NEWMA Interim Meetings: All four associations forwarded the item to NCWM, recommending it as an Informational Item. The SWMA, CWMA, and NEWMA recommended that the item to be developed by FALS.

2011 NCWM Interim Meeting: Mr. Ron Hayes, FALS Chair, reported that the Subcommittee recommended this item be Informational to allow more time for data to be reviewed. Historical data exists and a Coordinating Research Council (CRC) study is being done that will clarify issues and provide data that will assist with making a decision. There were no comments heard from the floor during Open Hearings. The 2011 L&R Committee designated this item as an Informational Item.

2011 NEWMA Annual Meeting: There were no comments heard on this item. The NEWMA L&R Committee recommended that this item move forward as an Informational Item.

2011 CWMA Annual Meeting: The FALS Chair indicated that they are waiting for results from the CRC study and recommends this remain Informational because it is not fully developed. The CWMA L&R Committee recommends that this item move forward as an Informational Item.

2011 NCWM Annual Meeting: It was noted that FALS was continuing to monitor and develop this item and the CRC was reviewing and analyzing the data from the CRC 660 study and additional industry data.

2011 CWMA Interim Meeting: Mr. Hayes said most new cars respond better to the research octane number rather than to the anti-knock index; however, this was still being studied by the CRC and research was ongoing. CWMA recommended that the item remain as an Informational Item.

2011 WWMA and SWMA Annual Meetings and the NEWMA Interim Meeting: All three associations recommended that the item remain as an Informational Item.

2012 NCWM Interim Meeting: FALS held a work session and heard no objections to recommending this item as Informational. Mr. Hayes reported to the Committee that a Task Group under FALS continues to work on this item. Mr. Albuquerque (Colorado), Task Group Chair, reported that information is still being gathered and recommended that it be an Informational Item. The 2012 L&R Committee designated this item as an Informational Item.

2012 NEWMA Annual Meeting: One person remarked that this is a non-issue. NEWMA recommended that the item remain as an Informational Item.

2012 CWMA Annual Meeting: No comments were received. CWMA recommended that the item remain an Informational Item.

2012 NCWM Annual Meeting: Two industry representatives supported further development of this item by the Task Group. Mr. Bill Studzinski (General Motors) will be leading the discussion on this item for the FALS. A stakeholder remarked that we do not need a task group for this item, and we should refer to ASTM.

2012 CWMA Interim Meeting: An oil company representative commented that ASTM does not have a minimum MON (Motor Octane Number) but recommends waiting for data from CRC. He recommended that the item remain Informational until the CRC data is available. General Motors commented that the available CRC data is still important. That data says that MON is still important. CWMA was neutral on the item and recommended that the item remain Informational until CRC octane data is available and reviewed by FALS.

2012 WWMA Annual Meeting: There were no comments. The Committee recommended that ASTM and FALS work in tandem to develop a proposal that provides a phase-out period. WWMA recommended that the item be an Informational.

2012 SWMA Annual Meeting: An industry member commented that this item, which was submitted several years ago, would be in conflict with the new item received this year; so if the new item goes forward, this item would be Withdrawn. SWMA supports this new item. SWMA recommended that the item be Withdrawn.

2012 NEWMA Interim Meeting: General Motors commented that CRC is working to produce data on this topic. Discussions indicated that this is contradictory to previous agenda item and should be Withdrawn. The Committee recommended if this item goes forward to NCWM, it should be assigned to the Fuels and Lubricants Subcommittee. NEWMA recommended that the item be Withdrawn.

2013 NCWM Interim Meeting: A stakeholder recommended that this item be Informational until it is further developed by ASTM. Mr. Hayes remarked that the FALS is also recommending this to be Informational. The Committee agrees and made this an Informational Item.

2013 NEWMA Annual Meeting: The Committee recommends that this item be Informational.

2013 CWMA Annual Meeting: The submitter requested this item be withdrawn. The Committee was informed that data now supports a minimum 82 octane number and this will be placed into the language for ASTM D 4814. The Committee concurs with the submitter and recommended this item be Withdrawn.

2013 NCWM Annual Meeting: The submitter of this proposal and the FALS agreed to Withdraw this item.

Additional letters, presentations and data may have been part of the Committee's consideration. Please refer to Appendix E in the *Report of the 97th National Conference on Weights and Measures* (SP 1160, 2012) to review these documents.

237-4 I Section 3.13 Oil, 3.13.1.4. Engine Service Category, 3.33.1.4.1. Vehicle or Engine Manufacturer Standard, and 3.13.1.4.12. Inactive or Obsolete Service Categories

Source:

Automotive Oil Change Association (2013)

Purpose:

Prevent consumer confusion and government-sponsored product bias regarding legitimate, manufacturer-recommended products, and to prevent installers and retailers from being held responsible for labeling requirements with respect to packaged goods.

Item Under Consideration:

Amend NIST Handbook 130, Engine Fuels and Automotive Lubricants Regulation as follows:

3.13. Oil.

3.13.1. Labeling of Vehicle Engine (Motor) Oil Required

3.13.1.1. Viscosity. – The label on any vehicle engine (motor) oil container, receptacle, dispenser, or storage tank and the invoice or receipt from service on an engine that includes the installation of vehicle motor oil dispensed from a receptacle, dispenser, or storage tank shall contain the viscosity grade classification preceded by the letters “SAE” in accordance with the SAE International’s latest version of SAE J300, “Engine Oil Viscosity Classification.”

(Amended 2012)

3.13.1.2. Intended Use. – The label on any vehicle engine (motor) oil container shall contain a statement of its intended use in accordance with the latest version of SAE J183, “Engine Oil Performance and Engine Service Classification (Other than “Energy Conserving”).”

(Amended 2012)

3.13.1.3. Brand. – The label on any vehicle engine (motor) oil container and the invoice or receipt from service on an engine that includes the installation of vehicle engine (motor) oil dispensed from a receptacle, dispenser, or storage tank shall contain the name, brand, trademark, or trade name of the vehicle engine (motor) oil.

(Added 2012)

3.13.1.4. Engine Service Category. – The label on any vehicle engine (motor) oil container, receptacle, dispenser or storage tank and the invoice or receipt from service on an engine that includes the installation of vehicle engine (motor) oil dispensed from a receptacle, dispenser, or storage tank shall contain the engine service category, or categories, met in letters not less than 3.18 mm ($\frac{1}{8}$ in) in height, as defined by the latest version of SAE J183, “Engine Oil Performance and Engine Service Classification (Other than “Energy Conserving”)” ~~or~~ API Publication 1509, “Engine Oil Licensing and

Certification System,” European Automobile Manufacturers Association (ACEA) European Oil Sequences.

(Amended 2012 and 20XX)

3.33.1.4.1. Vehicle or Engine Manufacturer Standard. – **The label on any vehicle engine (motor) oil container, receptacle, dispenser, or storage tank and the invoice or receipt from service on an engine that includes the installation of vehicle engine (motor) oil dispensed from a receptacle, dispenser, or storage tank shall identify the specific vehicle or engine manufacturer standard, or standards, met in letters not less than 3.18 mm (1/8 in) in height. If the vehicle (motor) oil only meets a vehicle or engine manufacturer standard, the label must clearly identify that the oil is only intended for use where specifically recommended by the vehicle or engine manufacturer.**

(Added 20XX)

3.13.1.4.2. Inactive or Obsolete Service Categories. – The label on any vehicle engine (motor) oil container, receptacle, dispenser, or storage tank and the invoice or receipt from service on an engine that includes the installation of vehicle engine (motor) engine oil dispensed from a receptacle, dispenser, or storage tank shall bear a plainly visible cautionary statement in compliance with the latest version of SAE J183, Engine Oil Performance and Engine Service Classification (Other than “Energy Conserving”)” Appendix A, whenever the vehicle engine (motor) oil in the container or in bulk does not meet an active API service category as defined by the latest version of SAE J183, “Engine Oil Performance and Engine Service Classification (Other than “Energy Conserving”).” **If a vehicle engine (motor) oil is identified as only meeting a vehicle or engine manufacturer standard, the labeling requirements in Section 3.13.1.4.1. Vehicle or Engine Manufacturer Standard apply.**

(Added 2012) **(Amended 20XX)**

3.13.1.5. Tank Trucks or Rail Cars. – Tank trucks, rail cars, and types of delivery trucks that are used to deliver vehicle engine (motor) oil are not required to display the SAE viscosity grade and service category or categories as long as the bill of lading other documentation provides that information.

(Added 2012)

~~All references to invoice or receipt will be enforceable effective on July 1, 2013.~~

(Amended 2012 and 20XX)

Background/Discussion:

The vast majority of engine oil used at professional fast lube facilities is the most current category of American Petroleum Institute (API) licensed oil. However, older, specialty, and some non-American vehicles take engine oil not listed as active under API’s private regulatory scheme; some are former API licensed oils now considered “obsolete” or “inactive” and some are simply licensed by another organization like ACEA. However, if the original equipment manufacturers (OEM) recommend those engine oils for their vehicles, consumers have a right to use them regardless of API’s blessing, and installers and retailers should be able to sell them without obstruction.

The Automotive Oil Change Association (AOCA) amendment is necessary because a cautionary statement appearing on service receipts without explanation will inappropriately mislead consumers with older and uncommon model vehicles into believing they should not use OEM-recommended engine oil. The average fast lube customer does not recognize API or SAE (Society of Automotive Engineers) to mean anything in particular but “CAUTION” and “OBSOLETE” in big capital letters could only be understood as negative. Scaring consumers in this way will not only push them to buy more expensive engine oil they don’t need, but also engender distrust in their installer service providers for recommending and/or using OEM-recommended engine oil.

The average age of cars in the current fleet is nearly 11-years old, and it is not unusual for fast lubes to have customers with vehicles twice that age; for example, there are millions of opportunities for consumers to be misled into rejecting proper engine oil. The fact is American consumers are hanging onto their vehicles longer than API is

hanging onto its service categories. When API designates a motor oil category as inactive, this does not mean consumers with vehicles designed to use that category turn in their cars or otherwise want to buy a more expensive grade of motor oil going forward. Therefore, a category of motor oil designed to work for particular makes and models of vehicles should not be burdened with the chilling effect of a cautionary statement absent a specific clarification acknowledging the preeminence of the OEM's recommendations.

The new standard phase-in factor must be considered as well. When API publishes a new edition of 1509, *Engine Oil Licensing and Certification System*, and/or creates a new service category, a reasonable phase-in period for bulk oil stock is necessary to accommodate older vehicle owners' needs; for example, it may be in those customers' best interests—both functionally and economically—to use motor oil developed in accordance with an earlier edition or service category so long as the automobile manufacturer originally recommended it and its continued use has no impact on any remaining warranty coverage. Although it is common for API to retain a couple of the most recent service categories as “active,” API could choose to make all but the most recent service category “obsolete.” For fast lube operators to automatically upgrade bulk oil stock at API-determined intervals would be tantamount to giving API control over the price of oil change services regardless of what the market can bear. And, what about packaged engine oil products already on the shelf or in the distribution chain when API makes a unilateral decision to deactivate an engine oil category? As a practical matter, tens of thousands of retailers and installers cannot remark millions of packages to coincide with API's timing or take the financial hit for sending it all back in violation of purchase agreements. Attempting to enforce the labeling requirement at this level would be a nightmare for everyone involved. The way to avoid this problem is to adopt AOCA's amendment so that the requirement for proper labeling of packaged containers of engine oil rest with the party in control of the packaging – the manufacturers.

Without the amendment, the labeling requirement will be very difficult to enforce given the inventory of packaged goods remaining after an active engine oil category has been declared inactive or obsolete. Fast lubes would experience catastrophic business loss if customers with older and uncommon model vehicles were alienated. Maintenance costs for consumers with older model cars could easily double if they are confused into believing they need the latest category of engine oil.

AOCA contends that the proposed amendment will accomplish three important goals: 1) prevent unintended consumer confusion and product stigma from using a cautionary statement by reestablishing the connection to OEM recommendations; and 2) provide the necessary exemption to protect retailers and installers for selling unlawful packaged inventory; which leads to 3) an increase in practical enforcement prospects.

The most analogous regulatory situation to the one at issue in AOCA's proposed amendment is found in the Federal Trade Commission's (FTC) Test Procedures and Labeling Standards for Recycled Oil (16 CFR 31, www.gpo.gov/fdsys/pkg/CFR-2011-title16-vol1/pdf/CFR-2011-title16-vol1-part312.pdf). In the rulemaking process, FTC specifically rejected requiring recycled engine oil to be labeled “recycled” because of the stigma associated with the term at that time (see 72 FR 14410 – 14413 & FN11, 1 H.R. Rep. No. 96–1415, 96th Cong. 2d Sess. 6 (1980), reproduced at 1980 U.S. Code Cong. & Ad. News 4354, 4356. “Oil should be labeled on the basis of performance characteristics and fitness for its intended use, and not on the basis of the origin of the oil.”). The National Automobile Dealers Association also commented in favor of this approach: “NADA further stated that by not requiring that “substantially equivalent” recycled oils be labeled “recycled” or “re-refined,” used oil processors are able to market their products effectively.” (72 FR at 14411) No “recycled” or other potentially derogatory designation is required so long as the finished product meets the appropriate API standard.

2012 CWMA Interim Meeting: AOCA stated that oil change businesses are small businesses without legal staff and they need clear guidance. These businesses follow the OEM recommendations, which recommend oils that do not follow API or SAE standards. The language should acknowledge that some manufacturers approve and recommend their own oil (i.e., General Motors (GM) and Audi-Volkswagen.) AOCA thought the current language required all OEM oils that did not meet a specific API performance standard to be labeled as obsolete. A GM representative confirmed that GM produces their own oil, Dexos (the best oil for any car), which does not have an API certification. A FALS member shared the API motor oil guide, (refer to Appendix C in this report, *Report of the 98th National Conference on Weights and Measures [2013]*) which labels specific categories of oil as obsolete. If a manufacturer does not label the oil with an API obsolete category, the product is not considered to be obsolete. OEM manufacturers that were named do not label their oil with an obsolete category, and so oil changers do not

need to worry about the obsolete label being used on OEM motor oils. AOCA also asked if there would be a grace period to sell product purchased prior to January 2013. States regulators clarified that nothing is written in the regulation, and grace periods would be determined on a state by state basis. AOCA reiterated that the language should clearly state that OEM oils that do not have API certification are not obsolete. AOCA also stated that installers should not be responsible for labeling on packaged products received. A regulatory official stated retailers in other industries are responsible for labeling on packages received, and it would be an unfair market advantage to allow some retailers to use products that were illegally labeled. Since the current language is not clear about exactly what oils are obsolete, the Committee recommended that FALS produce language for the NCWM Interim Meeting clearly stating that OEM recommended oils that are not API certified are not obsolete. CWMA forwarded the item to NCWM, recommending it as a Voting Item with the stipulation that FALS develop the clarifying language.

2012 WWMA Annual Meeting: Ms. Kristin Macey (California) opposed this item because it removes the retailer's accountability. Mr. Kevin Ferrick (API) opposed the additional language. Mr. Ferrick also provided a presentation to the WWMA and written comments to the Committee. Mr. Kurt Floren (Los Angeles County, California) opposed the language for similar reasons as stated by Ms. Macey. WWMA did not forward the item to NCWM.

2012 SWMA Annual Meeting: An API representative voiced API's opposition to the item and provided the written testimony in dispute of the comments and claims made by the submitter. The SWMA Committee believed there was lack of support for the item and that the oil change industry has a poor understanding of the API standards. SWMA did not forward the item to NCWM.

2012 NEWMA Interim Meeting: API stated that it opposes the item and that specifics have been submitted in writing. API suggested this proposal and Item 237-4 be Withdrawn. General Motors indicated the proposal appears to allow older formulations of engine oil, but newer formulations give better performance, even in older vehicles. GM prefers current formulation of engine oil. NEWMA did not forward the item to NCWM.

2013 NCWM Interim Meeting: A state opposed this item and would like to see it Withdrawn. The FALS Chairman remarked that there are several engine oils designed for specific model vehicles and FALS is working to resolve this issue. A Committee member remarked that a statement of accountability should be within the language. The Committee would like to see additional language developed by FALS and made this an Informational Item.

2013 NCWM Annual Meeting: FALS submitted modified language for Sections 3.33.1.4. Engine Service Category, 3.33.1.4.1. Vehicle or Engine Manufacturer Standard, and 3.33.1.4.1.2. Inactive or Obsolete Service Categories. The Committee would like to have regional input on this modified language to review at the 2014 NCWM Interim Meeting. The Item Under Consideration contains this modified language.

Additional letters, presentations, and data may have been part of the Committee's consideration. Please refer to Appendix B in the *Report of the 97th National Conference on Weights and Measures* (SP 1160, 2012), and Appendix C in this report (*Report of the 98th National Conference on Weights and Measures* [2013]) to review these documents.

237-5 V Section 3.13.1.4.5. Tank Trucks or Rail Cars and 3.13.1.6. Documentation

(This item was adopted.)

Source:

Automotive Oil Change Association (2013)

Purpose:

Make compliance and enforcement practical, efficient, and fair.

Item Under Consideration:

Amend NIST Handbook 130, Engine Fuels and Automotive Lubricants Regulation as follows:

3.13. Oil.

3.13.1. Labeling of Vehicle Engine (Motor) Oil Required

3.13.1.1. Viscosity. – The label on any vehicle engine (motor) oil container, receptacle, dispenser, or storage tank and the invoice or receipt from service on an engine that includes the installation of vehicle motor oil dispensed from a receptacle, dispenser, or storage tank shall contain the viscosity grade classification preceded by the letters “SAE” in accordance with the SAE International’s latest version of SAE J300, “Engine Oil Viscosity Classification.”

(Amended 2012)

3.13.1.2. Intended Use. – The label on any vehicle engine (motor) oil container shall contain a statement of its intended use in accordance with the latest version of SAE J183, “Engine Oil Performance and Engine Service Classification (Other than “Energy Conserving”).”

(Amended 2012)

3.13.1.3. Brand – The label on any vehicle engine (motor) oil container and the invoice or receipt from service on an engine that includes the installation of vehicle engine (motor) oil dispensed from a receptacle, dispenser, or storage tank shall contain the name, brand, trademark, or trade name of the vehicle engine (motor) oil.

(Added 2012)

3.13.1.4. Engine Service Category. – The label on any vehicle engine (motor) oil container, receptacle, dispenser, or storage tank and the invoice or receipt from service on an engine that includes the installation of vehicle engine (motor) oil dispensed from a receptacle, dispenser, or storage tank shall contain the engine service category, or categories, displayed in letters not less than 3.18 mm ($\frac{1}{8}$ in) in height, as defined by the latest version of SAE J183, Engine Oil Performance and Engine Service Classification (Other than “Energy Conserving”) or API Publication 1509, “Engine Oil Licensing and Certification System.”

(Added 2012)

3.13.1.4.1. Inactive or Obsolete Service Categories. – The label on any vehicle engine (motor) oil container, receptacle, dispenser, or storage tank and the invoice or receipt from service on an engine that includes the installation of vehicle engine (motor) engine oil dispensed from a receptacle, dispenser, or storage tank shall bear a plainly visible cautionary statement in compliance with the latest version of SAE J183, “Engine Oil Performance and Engine Service Classification (Other than “Energy Conserving”)” Appendix A, whenever the vehicle engine (motor) oil in the container or in bulk does not meet an active API service category as defined by the latest version of SAE J183, “Engine Oil Performance and Engine Service Classification (Other than “Energy Conserving”).”

(Added 2012)

3.13.1.4.5. Tank Trucks or Rail Cars. – Tank trucks, rail cars, ~~or~~ and types of delivery trucks that are used to deliver vehicle engine (motor) oil are not required to display the SAE viscosity grade and service category or categories **on such tank trucks, rail cars, and other types of delivery trucks as long as the bill of lading or other documentation provides that information.**

(Added 2012) **(Amended 2013)**

3.13.1.6. Documentation. – **When the engine (motor) oil is sold in bulk, an invoice, bill of lading, shipping paper, or other documentation must accompany each delivery. This document must identify the quantity of engine (motor) oil delivered as defined in Section 3.13.1.1. Viscosity; Section 3.13.1.2. Intended Use; Section 3.13.1.3. Brand; Section 3.13.1.4. Engine Service Category; the name and address of the seller and buyer; and the date and time of the sale. For inactive or obsolete service categories, the documentation shall also bear a plainly visible**

cautionary statement as required in Section 3.13.1.4.1. Inactive or Obsolete Service Categories, documentation must be retained at the retail establishment for a period of not less than one year.
(Added 2013)

~~All references to invoice or receipt will be enforceable effective on July 1, 2013.~~
(Amended 2012 **and 2013**)

Background/Discussion:

There is a chain of engine oil purchasers involved in the sale of bulk engine oil, all of whom need accurate and adequate information about the commodity so that they can make price and quantity comparisons. The engine oil distributor is a purchaser with respect to engine oil manufacturers, the installer is a purchaser with respect to engine oil distributors, and the consumer is a purchaser with respect to installers. Installers like fast lube operators can only provide accurate and adequate information about bulk engine oil to consumers if their distributors provide it at the point of delivery. It would be manifestly unfair to expect installers to legally vouch in writing for the quality of distributors' engine oil products absent a corresponding written verification requirement.

The original language for consideration (refer to the *Report of the 97th National Conference on Weights and Measures* [SP 1160, 2012], L&R Committee Report) creating a Method of Sale for Section 2.33.1.4.2. Tank Trucks and Rail Cars and an Engine Fuels and Automotive Lubricants Regulation for Section 3.13.1.4.2. Tank Trucks or Rail Cars inadvertently created a loophole for distributors to avoid providing necessary product documentation at the time of delivery.

Whether or not NCWM waives tank truck labeling is not the issue. The problem lies in the converse this provision allows: if a distributor displays the SAE viscosity grade and service category on a tank truck, then they do not have to provide a bill of lading. This poses a serious risk to installers like fast lubes because the regulation requires them to vouch for viscosity grade, service category, and brand on customer receipts but does not guarantee that they will receive that same information in writing from their distributors—the parties with actual control over product quality/identity.

There is also no practical way for fast lubes or NCWM to enforce this “either/or” regulatory scenario. If a distributor arrives at an installer’s facility without documentation, how can the installer hold the distributor to it under NIST Handbook 130? The distributor can simply claim their truck is adequately marked. Installers are not professional truck inspectors; they cannot be expected to act as enforcement agents in this scenario. Meanwhile, in order for local weights and measures officials to hold a distributor accountable, the official would have to arrive on the scene at the time of delivery, which is unlikely at best. Any subsequent official inquiry would take place after the distributor has had the opportunity to subsequently mark any unmarked truck at issue. Moreover, risk of distributor failure in providing necessary documentation is high because most do not and never have been willing to provide bills of lading or other documentation to fast lubes at the time of delivery.

Additionally, the imperative for any installer labeling and/or receipt information requirements to be matched by corresponding requirements for engine oil distributors includes “brand.” Installers cannot purport to verify via any form of documentation information that distributors have not documented at delivery. Method of Sale, Section 2.33. Oil and Engine Fuels and Automotive Lubricants Regulation, Section 3.13. Oil requires installers to verify brand in writing and, therefore, distributors should be required to verify it, too. For NCWM to require otherwise would be manifestly unfair to installers by subjecting them to liability for the bad acts of distributors without any paperwork trail to rely upon in their own defense.

No one has more at stake than installers. Should a product quality problem occur with packaged goods, it’s relatively easy to trace the goods back to the manufacturer. However, this is not the case with motor oil transported in bulk; it all looks alike, it may have “changed hands” numerous times before reaching the fast lube facility, and even with testing can be impossible for a fast lube to verify because oil companies use chemical markers that only they can identify. Since motor oil specifications have become so precise and so expensive—fast lube operators stand to lose thousands of dollars every time a distributor delivers a lesser product. Moreover, when a distributor delivers the wrong product, it’s the fast lube operator who gets stuck holding the bag for consumer claims, which can be excessive if the “wrong” product did or could cause engine damage. It takes weeks before a bad load of motor oil is

detected and by then anywhere from 500 to 700 customers has been serviced. The remedy? All of the customers must be called back and re-serviced for free before any damage has the opportunity to occur. Requiring distributors to provide the same documentation required of installers represents the minimum necessary step to at least protect installers from misrepresentation claims when a distributor “mis-delivers” bulk oil.

API and ILMA have been publicly quoted as supporting the requirement that distributors provide documentation at delivery as the new paragraphs at issue already mandate it under all circumstances. See Lube Report (August 1, 2012) www.imakenews.com/lng/e_article002489327.cfm?x=b11,0,w

EPA’s Federal Used Oil Management Standards require detailed transporter chain of custody documentation (40 CFR Part 279). See also EPA’s *Chain-of-Custody Procedures for Samples and Data* (www.epa.gov/apti/coc/), which makes clear that failure to maintain a proper chain of custody regarding samples and/or data will destroy any ability to defend oneself if challenged.

According to the U.S. Department of Agriculture (USDA), segregation and documentation for specialty (bulk) crops continue from the elevator to the final producer or consumer. [*Traceability in the U.S. Food Supply: Economic Theory and Industry Studies* (USDA Economic Research Service 2004)].

Under the FDA Food Modernization Act (Public Law 111-353), documenting the production and distribution chain of food products is required so that “in case of a problem, a product can be traced back to the source.”

DOT overlaps with EPA regarding the Federal Hazardous Waste Manifest System (40 CFR Part 262), which mandates detailed documentation of hazardous waste from cradle to grave; for example, from generator to transporter to end user/disposal.

The submitter provided the following websites as evidence that “Mis-delivery of liquid products must happen with some recognized frequency because the subject is big business for the insurance industry.”

<http://www.johannesagency.com/petroleum>

- <http://www.canalinsurance.com/coverage/truckers-general-liability>
- <http://www.marianoagency.com/programs/transportation>
- <http://falcigno.com/products-a-services/environmentalchemical>
- <http://www.iaaofillinois.org/convention2011/documents/SpeakerOutlines/CGL%20and%20Auto%20Endorsements.pdf>
- <http://www.safapeoria.com/data/uploadDirectory/applications/commercialauto/EMPIRE%20FIRE%20AND%20MARINE/Motor%20Carrier/motor%20carrier.pdf>
- <http://www.big-ins.com/generalapps/SupplAppFuelMkrs2003.pdf>
- <http://www.insurancecommunityuniversity.com/UniversityResources/InsuranceGlossaryFREE/InsuranceGlossaryM/MisdeliveryofLiquidProductsCoverageCommercial.aspx>

2012 CWMA Interim Meeting: AOCA stated that the current language would allow the distributor to either label the truck or tank car or the bill of lading. The language should clearly state that distributor needs to provide the retailer with a bill of lading or other documentation that includes product identity information. A FALS member acknowledged that the current language could be construed to say that the distributor does not need to provide this documentation, and this was not the intent. The Committee recommends that FALS provide concise language that states that a bill of lading or other documentation with appropriate product information must be provided to the retailer. FALS should submit proposed language to the NCWM L&R Committee for the Interim meeting. CWMA

forwarded the item to NCWM, recommending it as a Voting Item with the stipulation that FALS develop language. In 2013 at the CWMA Annual meeting there was continued support for this to be a Voting Item.

Mr. Ferrick provided a presentation at the 2012 WWMA Annual Meeting. Mr. Ferrick remarked that the submitted proposal was rather wordy; however, he does not disagree with the language. Ms. Kristin Macey (California) supported the submitted proposal. The Committee agreed that the submitted proposal is too lengthy and presented alternative language for consideration. The Committee regretted that the submitter was not present to answer questions. WWMA forwarded the item to NCWM, recommending it as an Informational Item as modified:

3.13.1.4.5. Tank Trucks or Rail Cars. – Tank trucks, rail cars, and other types of delivery trucks that are used to deliver vehicle engine (motor) oil are not required to display the SAE viscosity grade and service category or categories, however as long as the bill of lading or other documentation shall provides that information.

2012 SWMA Annual Meeting: The committee agreed that adequate documentation should be provided. SWMA recommends this as a Voting Item.

2013 NEWMA Annual Meeting: The NEWMA L&R Committee believes this item is fully developed and recommends this to be a Voting Item.

2013 NCWM Interim Meeting: Mr. Hayes remarked that FALS is recommending language changes for this item. FALS developed Section 3.13.1.6. Documentation, which resolves the issues brought before the Subcommittee. FALS recommended to the Committee that the revised language move forward as a Voting Item. The Committee concurs with the language revisions and proposed this item be a Voting Item. At the 2013 NCWM Annual Meeting FALS informed the Committee that this item is fully developed. The Committee recommended the item be presented for a Vote.

237-6 W Section 3.15. Biodiesel and Biodiesel Blends

(This item was withdrawn.)

Source:

Southern Weights and Measures Association (2010)

Purpose:

Remove the exemption for declaration of biodiesel content on product transfer documents for biodiesel blends up to 5 %.

Item Under Consideration:

Amend the NIST Handbook 130, Engine Fuels and Automotive Lubricants Regulation as follows:

3.15. Biodiesel and Biodiesel Blends.

3.15.1. Identification of Product. – Biodiesel shall be identified by the term “biodiesel” with the designation “B100.” Biodiesel blends shall be identified by the term “Biodiesel Blend.”

3.15.2. Labeling of Retail Dispensers.

3.15.2.1. Labeling of Grade Required. – Biodiesel shall be identified by the grades S15 or S500. Biodiesel blends shall be identified by the grades No. 1-D, No. 2-D, or No. 4-D.

3.15.2.2. EPA Labeling Requirements Also Apply. – Retailers and wholesale purchaser-consumers of biodiesel blends shall comply with EPA pump labeling requirements for sulfur under 40 CFR § 80.570.

3.15.2.3. Automotive Fuel Rating. – Biodiesel and biodiesel blends shall be labeled with its automotive fuel rating in accordance with 16 CFR Part 306.

3.15.2.4. Biodiesel Blends. – When biodiesel blends greater than 20 % by volume are offered by sale, each side of the dispenser where fuel can be delivered shall have a label conspicuously placed that states “Consult Vehicle Manufacturer Fuel Recommendations.”

The lettering of this legend shall not be less than 6 mm (¼ in) in height by 0.8 mm (1/32 in) stroke; block style letters and the color shall be in definite contrast to the background color to which it is applied.

3.15.3. ~~Documentation for Dispenser Labeling Purposes Required on Transfer Documents.~~ – ~~The retailer shall be provided, a~~At the time of delivery of the fuel, a declaration of the volume percent biodiesel ~~on an invoice, bill of lading, shipping paper, or other document, shall be disclosed on all transfer documents.~~ ~~This documentation is for dispenser labeling purposes only;~~ ~~i~~It is the responsibility of any potential blender to determine the amount of biodiesel in the diesel fuel prior to blending.

(Amended 20XX)

3.15.4. Exemption. – ~~Biodiesel blends that contain less than or equal to 5 % biodiesel by volume are exempted from the requirements of Sections 3.15.1. Identification of Product, 3.15.2 Labeling of Retail Dispensers, and 3.15.3. Documentation for Dispenser Labeling Purposes when it is sold as “diesel fuel” as required in Section 3.3. Diesel Fuel.~~

- (a) Biodiesel blends that contain less than or equal to 5 % biodiesel by volume are exempted from the requirements of Sections 3.15.1. Identification of Product, and 3.15.2. Labeling of Retail Dispensers when it is sold as “diesel fuel” as required in Section 3.3. Diesel Fuel.
- (b) Diesel fuel containing less than 1 % by volume biodiesel is exempted from the requirement of Section 3.15.3. Documentation for Dispenser Labeling Purposes Required on Transfer Documents.
- (c) Diesel fuel containing 1 % and not more than 5 % by volume biodiesel fuel is exempt from disclosing the actual percent by volume of biodiesel as required in Section 3.15.3. Documentation for Dispenser Labeling Purposes. However, the term “Contains Biodiesel” or other similar terms shall be used.

(Added 2005) (Amended 2008 and 20XX)

Background/Discussion:

2009 SWMA Annual Meeting: A discussion over blending was presented by a FALS member. Biodiesel is being blended at many terminals across the country in concentrations up to 5 %. Marketers downstream of the terminal are then attempting to blend additional biodiesel to target levels, and finding that their product is being over-blended because they were not aware that the fuel contained any biodiesel. According to Mr. Jennings (Tennessee Department of Agriculture) at least one major truck stop operator has already voiced concerns to the FALS Chair. This amended proposal will remove the exemption declaration of biodiesel content on product transfer documents for biodiesel blends up to 5 %. Biodiesel is blended at terminals in concentrations up to 5 %. Mr. Jennings believed it was important to start this recommendation and have the FALS Chair get the proposal out to all members of the FALS for their comments before NCWM Interim meeting in January 2010. SWMA forwarded the item to NCWM, recommending it as a Voting Item.

3.15. Biodiesel and Biodiesel Blends

3.15.1. Identification of Product. – Biodiesel shall be identified by the term “biodiesel” with the designation “B100.” Biodiesel blends shall be identified by the term “Biodiesel Blend.”

3.15.2. Labeling of Retail Dispensers.

3.15.2.1. Labeling of Grade Required. – Biodiesel shall be identified by the grades S15 or S500. Biodiesel blends shall be identified by the grades No. 1 D, No. 2 D, or No. 4 D.

3.15.2.2. EPA Labeling Requirements Also Apply. – Retailers and wholesale purchaser-consumers of biodiesel blends shall comply with EPA pump labeling requirements for sulfur under 40 CFR § 80.570.

3.15.2.3. Automotive Fuel Rating. – Biodiesel and biodiesel blends shall be labeled with its automotive fuel rating in accordance with 16 CFR Part 306.

3.15.2.4. Biodiesel Blends. – When biodiesel blends greater than 20 % by volume are offered by sale, each side of the dispenser where fuel can be delivered shall have a label conspicuously placed that states “Consult Vehicle Manufacturer Fuel Recommendations.”

The lettering of this legend shall not be less than 6 mm (¼ in) in height by 0.8 mm (1/32 in) stroke; block style letters and the color shall be in definite contrast to the background color to which it is applied.

3.15.3. Documentation for Dispenser Labeling Purposes. – The retailer shall be provided, at the time of delivery of the fuel, a declaration of the volume percent biodiesel on an invoice, bill of lading, shipping paper, or other document. ~~This documentation is for dispenser labeling purposes only; it is the responsibility of any potential blender to determine the amount of biodiesel in the diesel fuel prior to blending.~~

3.15.4. Exemption. – Biodiesel blends that contain less than or equal to 5 % biodiesel by volume are exempted from the requirements of Sections 3.15.1. Identification of Product, **and** 3.15.2. Labeling of Retail Dispensers, ~~and 3.15.3. Automotive Fuel Rating~~ when it is sold as “diesel fuel” as required in Section 3.3. Diesel Fuel.

(Added 2005) (Amended 2008 **and 20XX**)

2010 NCWM Interim Meeting: Mr. Hayes, FALS Chair, gave an update on the Subcommittee’s work to remove the current exemption for biodiesel disclosure in diesel fuel at 5 % and below on product transfer documents.

A draft of substitute language was circulated among FALS members prior to the Interim Meeting. This substitute language expanded the disclosure of biodiesel content on all transfer documents (not limited to ones to the retailer) and for levels greater than 1 % biodiesel. The substitute was an attempt to find middle ground. FALS members were more agreeable to this substitute, but many still thought more work was needed.

The L&R and FALS received seven letters (refer to L&R Appendix E within the *Report of the 95th National Conference on Weights and Measures* [SP 1115, 2010]) that do not support this proposal as stated. The Committee does support working on this issue and receiving feedback from industry. There is concern with the documentation and comingling of fuels. If fuel is comingled, it would need to be sampled every time, which could be quite costly.

An official requested that this item move forward as a Voting Item and meanwhile NEWMA and CWMA could review and further develop the language at their spring 2010 meetings. API stated there are many things to consider, such as preemption language, cost implications, commercial issue of declaring with each transaction. A PI has worked with marketers, but there continues to be a difference of opinion and no consensus. It was voiced by industry that all biodiesel needs to be documented on the paperwork. If not, it puts the wholesaler, retailer, and consumer at risk. There was a comment from a stakeholder that they do not agree with API’s comment and that this has been a two-year battle on who gets to do the blending. Blenders are over-blending because they are not aware of what the current blend is. To prevent this situation, it would require disclosure on the transfer document. The 2010 L&R Committee designated this item as an Informational Item.

2010 NEWMA Annual Meeting: A stakeholder reported that FTC has not changed the existing posting rule. NEWMA recommended that the item remain as an Informational Item.

2010 CWMA Annual Meeting: Several commented that the exact percentage of an alternative fuel needs to be known. Without the percentage being known, mislabeling can occur, which is not good for consumers, marketers, and the environment and renewable fuels. What is the downside of providing this information? A representative of the National Biodiesel Board (NBB) does not support this proposal and would like to have further discussions to seek what is best for the entire industry. They also commented that FTC declined to modify requirements for disclosure on product transfer documents for fuels containing 5 % or less biodiesel. An official disagreed that the exact percentage is necessary since it is the blender's responsibility to test the product prior to blending. A representative of the Renewable Fuels Association would like to see the proposal expanded to include all additives and stated that the focus needs to be in broader terms instead of renewable fuels and recommended that the scope include all blending components. CWMA recommended that the item remain as an Informational Item and that FALS form a task group under their guidance to develop this proposal.

2010 NCWM Annual Meeting: The Committee received numerous letters (refer to Appendix E within the *Report of the 95th National Conference on Weights and Measures* [SP 1115, 2010]) and heard from fifteen stakeholders and industry representatives, supporting Section 3.15.3. Documentation for Dispenser Labeling Purposes that requires disclosure. Several participants expressed concerns with sections of the proposal. FTC has the authority to protect consumers, and they are considering requirements for product transfer documents. Several stakeholders indicated that they expect FTC to issue a proposed rule on biodiesel. The sections that are of concern to stakeholders are Section 3.15.4. Exemption (b) and (c), since they conflict with reporting of tax collections on biodiesel. The exact amount of the blend needs to be documented on the transfer document. The concern is when fuel is picked up from various locations and delivered; the actual amount of biodiesel is not documented. Currently blending at the terminal is not an issue. The L&R Committee agreed to allow time for the FALS to receive additional information and further discuss this item.

2010 CWMA Interim Meeting: A representative from a Petroleum Marketers Association commented that disclosure sets the tone for a chain of events for biodiesel. It was important for disclosure to be provided all the way through the distribution process because of the potential for over-blending. He believes that it is not realistic for wholesale distributors to test for biodiesel due to the cost. He supports the proposal with exception of the exemptions provided in Section 3.15.4. Exemption (b) and (c). An official agreed with this testimony. Another official commented that the current proposal follows the same format as the ethanol regulation. A petroleum dealer mentioned that, due to the expanded Renewal Fuels Standard (RFS), disclosure is needed in order to meet the mandates for blending.

A representative with the NBB commented that this proposal needs further development by FALS. She believes that we have not heard from all segments of the industry regarding this proposal. She also expressed concern that there will be no benefit to consumers if the cost of the extra testing of fuel is being passed on to consumers. It was mentioned that there are quick testing methods available for determining biodiesel content in the field; although, some are more accurate than others. The NBB representative also stated that the FTC believes it is the responsibility of the blender to determine biodiesel content prior to blending.

A producer mentioned that the disclosure proposal would require terminals to purchase equipment and to do additional testing. The producer is concerned about tank stratification and the need to change bills of lading as the content varies. Cost and manpower are major concerns for producers. A marketer provided testimony that it is more efficient for terminals to purchase testing equipment as opposed to requiring all downstream blenders to purchase testing equipment. He stated that changing bills of lading is only a software change. He believes that it is the blenders' obligation to meet the law for labeling, and it is difficult if the biodiesel content is not disclosed. The NBB representative questioned how often marketers test. A marketer responded that they do not routinely test; since they rely on transfer documents to accurately disclose biodiesel content. A nother marketer stated that producers can control what goes into their tanks and questioned if producers know how much biodiesel is in each batch. A producer responded that for barrels received by water in Savannah, Georgia, the biodiesel content is only disclosed on Plantation pipeline shipments if it is more than 5 %. The CWMA recommended that the item remain as an Informational Item to be further developed by FALS.

2010 WWMA and SWMA Annual Meetings: An industry representative spoke in support of keeping this item Informational and allowing FALS to further develop the requirements in light of the comments received. An

industry representative stated that all shipping documents should show the exact blend of biodiesel. Both Associations recommended that the item remain as an Informational Item.

2010 NEWMA Interim Meeting: The Committee received written comments from API. NEWMA recommended that the item remain as an Informational Item.

2011 NCWM Interim Meeting: A member of both the FALS and L&R Committee reported that this item was debated during the FALS work sessions and a consensus could not be reached. It was agreed upon that a Biodiesel Disclosure Task Group be formed to further study this item. Mr. Howell, MARC-IV, and Mr. Bell, Echols Oil Company, Inc. will co-chair this Task Group. The Committee received five letters yet no additional comments were received in Open Hearings. The 2011 L&R Committee designated this item as an Informational Item.

FALS reported that a smaller work group of its members plan to complete a report containing possible solutions and present it to FALS at the 2012 NCWM Interim Meeting in January.

2011 NEWMA Annual Meeting: A consultant with the National Biodiesel Board (NBB) stated that a report is being prepared and will be ready for the 2011 Annual NCWM meeting. NEWMA recommended that the item remain as a Developing item.

2011 CWMA Annual Meeting: Mr. Ron Hayes, FALS Chairman and representative of Missouri, remarked that a WG was formed under FALS to develop new language. A petroleum representative opposed the item as written as it does not allow the blender to disclose what level blending has occurred. Another petroleum representative remarked that there are other implications beyond small percentages of biodiesel with other additives. It was agreed that as blender you should know exactly what you are getting, but it needs to be tested. The question is who is the responsible party for providing the test? The CWMA recommended that the item remain as a Developing item.

2011 NCWM National Meeting: Mr. Hayes reported that a Subcommittee under FALS has been formed to work out a compromise on the requirements and a report with solutions should be prepared for FALS at the 2012 NCWM Interim Meeting.

2011 CWMA Interim Meeting: The NBB representative stated a task group was formed under the guidance of FALS to develop language. The Petroleum Marketers and Convenience Store of Iowa (PMCI) representative stated there were 137 biodiesel blenders in Iowa and the current proposed language is a real concern to blenders, especially the 5 % blenders. The marketers do not support an exemption for blends of 5 % or less on the product transfer documents. One official agreed and suggested removing the exemption for 5 % blends stating that if percentage is known it reduces the need for downstream testing. The NBB representative countered that testing adds a lot of cost before the product reaches the consumer and that 5 % biodiesel or less meets the ASTM D975 diesel fuel specification and there is no performance difference. She also stated the current proposed language may be the best compromise that can be achieved. The official reported that terminals in her state already certify how much biodiesel leaves the terminal. The NBB representative countered that biodiesel was developed as a fungible product and is a drop-in fuel. Further, fungibility issues dictate that we not disclose the exact biodiesel content. The PMCI representative stated that gallons of biofuel must be reported, and the language in Item 237-3 (refer to *the Report of the 96th National Conference on Weights and Measures* (SP 1125, 2011) is a compromise because his constituents did not have input into the exemption language. An energy company representative stated that Plantation Pipeline is saying diesel fuel may contain up to 5 % biodiesel. Therefore, batch certification would be required to determine content. Stratification is also a concern because even batch testing may not be indicative of the true content. The PMCI representative stated this issue is really about the Renewable Identification Number (RIN) credit and how they are bought and sold. The NBB representative stated that weights and measures are most concerned with making sure there is equity in the marketplace and that profitability in the marketplace is left up to the market. An official questioned where the burden of analysis lies and if the blender is making a profit then it is reasonable to expect the blender to bear the cost. FALS is currently gathering information on this item. CWMA recommended that the item remain as an Informational Item.

2011 WWMA Annual Meeting: There were no comments heard. The Committee would like to get a recommendation from FALS before taking further action. WWMA recommended that the item remain as an Informational Item.

2011 NEWMA Interim Meeting: It was agreed that any action taken should be consistent with other federal agency labeling. NEWMA recommended that the item remain as an Informational Item.

2011 SWMA Annual Meeting: A representative of the NBB conveyed a message on behalf of the chair of FALS, that it will meet before the NCWM Interim Meeting and provide a report to FALS for the L&R Committee. SWMA recommended that the item remain as an Informational Item.

2012 NCWM Interim Meeting: FALS met and Mr. Bell and Mr. Howell, Task Group Co-Chairs provided a presentation on the updated data and study. They presented a written report to FALS on January 17, 2012. A plan was submitted for the activities of this Task Group for the next eighteen months. FALS recommended that this item remain as an Informational Item. The 2012 L&R Committee designated this item as an Informational Item.

2012 NEWMA Annual Meeting: There were no comments on this item. NEWMA recommended that the item remain as an Informational Item.

2012 CWMA Annual Meeting: Mr. Hayes remarked that Steve Howell and Sam Bell have written a white paper on this item and the paper will be posted on the NCWM website prior to the 2012 NCWM Annual Meeting. CWMA recommended that the item remain as an Informational Item.

2012 NCWM Annual Meeting: Mr. Hayes, FALS Chairperson, reported that Mr. Bell and Mr. Howell gave a presentation to the Subcommittee, however; there was no consensus on how to move forward with this item.

2012 CWMA Interim Meeting: The FALS Chairman reported that the WG did not reach a consensus and recommended withdrawing the item. A regulatory official asked if withdrawing the item would cause harm. Another stated that biodiesel marketers needed to know biodiesel content, and that the item should move forward as a Voting Item. The Iowa Petroleum Marketers representative said this is a state enforcement issue and the item should be withdrawn. He said that 16-CFR 306 does not address diesel. Iowa had already passed regulations for this and the language in this item would not work in Iowa. Another official recommended moving forward as a Voting Item. A National Biodiesel Board representative said while NBB tries to remain neutral, that this language could have unintended consequences for states where biodiesel is not produced or marketed, resulting in unnecessary testing for biodiesel content. A regulatory official stated that biodiesel is present in states that do not produce or market it. She also stated that some consumers don't want biodiesel content. NIST Handbook 130 is currently consistent with FTC regulations, and NBB recommends Withdrawing this item. FTC reviewed this issue and did not support further disclosure of biodiesel content. Many states do not produce biodiesel, and many states that do produce biodiesel already have state regulations in place that would pre-empt NCWM standards. The work group has attempted for several years to reach consensus and was unable to do so. For these reasons, CWMA recommended that the item be Withdrawn.

2012 WWMA Annual Meeting: Ms. Rebecca Richardson (NBB) remarked that she heard Mr. Hayes, FALS Chairperson, inform CWMA this fall that FALS could not be agree on alternate language and recommended this item be Withdrawn. The Committee would like to get an update from FALS at the 2013 NCWM Interim Meeting. WWMA recommended that the item be an Informational Item.

2012 SWMA Annual Meeting: An industry representative from the National Biodiesel Board (NBB) commented that since this item was introduced in 2010, both the NCWM L&R Committee and the Fuels and Lubricants Subcommittee assigned this issue to a smaller work group co-chaired by Mr. Steve Howell and Mr. Sam Bell. There have been several concerns expressed during the vetting of this proposal, and ultimately the industry could not come to a consensus on the proposed language or any alternative. In fact, considering oral testimony and comments from the work group, the proposed language, which was a compromise from the original submission, was less desirable among fuel producers, marketers, and pipeline representatives. Since the proposed language was introduced, technology for the rapid analysis of biodiesel blends has become more sophisticated, and there are more tools to determine accurate biodiesel blends in real time. Anyone who wishes to blend biodiesel has the ability to determine the blend they are starting with before they add more. Since the NBB has concerns about negative, unintended consequences from this proposed new disclosure requirement, and considering the industry could not come to consensus on national model language, NBB's recommendation is that states need to determine individually whether or not local conditions and regulations make it necessary to further disclose biodiesel blends below 5 % within their

own markets. Therefore, the NBB recommends that this proposal be Withdrawn. A letter to FALS on the task group recommendation will be provided before the NCWM Interim Meeting. The letter will include a recommendation that the Task Group be disbanded. A state official recommended the item be either Withdrawn or made a Voting Item, since the item has been on the agenda since 2010. The Committee recommended that the item be retained as Informational until a recommendation is received from FALS. SWMA recommended that the item be an Informational Item.

2012 NEWMA Interim Meeting: The NBB gave an update. There is no consensus on the issue. NBB recommended that item be Withdrawn consistent with FALS position. NEWMA recommended that the item be Withdrawn.

2013 NCWM Interim Meeting: Sam Bell who co-chairs of a task group under stated they could not reach consensus on this item. FALS recommended to the Committee that this item be Withdrawn in its entirety. The Committee concurs with FALS' recommendation to Withdraw this item.

2013 NEWMA and CWMA Annual Meetings: Both associations concur that this item should be Withdrawn.

2013 NCWM Annual Meeting: The Committee accepted the recommendation of the FALS to Withdraw this item.

Additional letters, presentations and data may have been part of the Committee's consideration. Please refer to Appendix G in the *Report of the 97th National Conference on Weights and Measures* [SP 1160, 2012] to review these documents.

237-7 W Sections 3.2. Automotive Gasoline and Automotive Gasoline-Oxygenate Blends, 3.8. E85 Fuel Ethanol, and 3.9. M85 Fuel Methanol

(This item was withdrawn.)

Source:

Missouri Department of Agriculture (2013)

Purpose:

Reduce the potential for misfueling consumer vehicles.

Item Under Consideration:

Amend NIST Handbook 130 Engine Fuels and Automotive Lubricants Regulation as follows (renumbering remaining paragraphs accordingly):

3.2. Automotive Gasoline and Automotive Gasoline-Oxygenate Blends.

3.2.1. Posting of Product Name Required ~~Antiknock Index Required~~ — All automotive gasoline and automotive gasoline-oxygenate blends shall post the antiknock index in accordance with applicable regulations, 16 CFR Part 306 issued pursuant to the Petroleum Marketing Practices Act, as amended. Dispenser nozzle(s) shall conspicuously display the product name

Example: Gasoline or E15 Gasoline

3.2.12. Posting of Antiknock Index Required. – All automotive gasoline and automotive gasoline-oxygenate blends shall post the antiknock index in accordance with applicable regulations, 16 CFR Part 306 issued pursuant to the Petroleum Marketing Practices Act, as amended.

3.8. E85 Fuel Ethanol.

3.8.1. Posting of Product Name Required. – Dispenser nozzle(s) shall conspicuously display the product name ~~How to Identify E85 Fuel Ethanol. – Fuel ethanol shall be identified as E85.~~

Example: E85 or Ethanol Flex Fuel

3.8.1.2. How to Identify E85 Fuel Ethanol. – Fuel ethanol shall be identified as E85.

3.8.2.3 Labeling Requirements.

- (a) Fuel ethanol shall be labeled with its automotive fuel rating in accordance with 16 CFR Part 306.
- (b) A label shall be posted which states “For Use in Flexible Fuel Vehicles (FFV) Only.” This information shall be clearly and conspicuously posed on the upper 50 % of the dispenser front panel in a type at least 12.7 mm (½ in) in height, 1.5 mm (1/16 in) stroke (width of type). A label shall be posted which states, “Consult Vehicle Manufacturer Fuel Recommendations,” and shall not be less than 6 mm (¼ in) in height by 0.8 mm (1/32 in) stroke; block style letters and the color shall be in definite contrast to the background color to which it is applied.

(Amended 2007, ~~and 2008,~~ **and 20XX**)

3.9. M85 Fuel Methanol.

3.9.1. ~~How to Identify M85 Fuel Methanol. – Fuel methanol shall be identified as M85.~~ Posting of Product Name Required – Dispenser nozzle(s) shall conspicuously display the product name.

Example: M85

3.9.1.2 How to Identify M85 Fuel Methanol. – Fuel methanol shall be identified as M85.

Example: M85

3.9.2.3. Retail Dispenser Labeling.

- (a) Fuel methanol shall be labeled with its automotive fuel rating in accordance with 16 CFR Part 306.

Example: M85 Methanol

- (b) A label shall be posted which states “For Use in Vehicles Capable of Using M85 Only.” This information shall be clearly and conspicuously posted on the upper 50 % of the dispenser front panel in a type of at least 12.7 mm (½ in) in height, 1.5 mm (1/16 in) stroke (width of type).

(Amended 2008 **and 20XX**)

Background/Discussion:

The level of confusion for consumers fueling vehicles continues to grow with the introduction of new fuels in the marketplace. This amendment would ensure proper delivery of the selected product and reduce the potential of mis-fueling vehicles. Missouri and other states have received complaints from consumers who have fueled their vehicles with inappropriate products. At this time, practically all gasoline dispensers nationwide do not comply with NIST Handbook 44, Section UR.3.2. or S.1.6.4.2.(a) as they do not display the product identity (i.e., gasoline).

2012 CWMA Interim Meeting: One official supported the item, but recommended that FALS review the language so that stakeholders on that Subcommittee have an opportunity to review the language. An ethanol industry representative also supported the item, stating that the language should be reviewed by industry stakeholders. CWMA supported the item; recommending FALS review. CWMA forwarded the item to NCWM recommending it as an Informational Item.



2012 SWMA Annual Meeting: The Committee heard opposition from an industry member and support from a regulatory official. SWMA forwarded the item to NCWM, recommending it as an Informational Item.

2012 NEWMA Interim Meeting: Members expressed concern for additional clutter on retail dispensers. There was also concern that nozzles could end up on products that do NOT match the product being dispensed. One member indicated that the consumer has some responsibility for making the proper product choice when at the dispenser. NEWMA forwarded the item to NCWM

recommending it as an Informational Item.

2013 NCWM Interim Meeting: Ron Hayes, FALS Chairperson, remarked that there is no support in FALS for this item and FALS is recommending it be Withdrawn. The Committee concurs with FALS and Withdrew this item.

2013 CWMA and NEWMA Annual Meetings: Both Associations recommended this item be Withdrawn.

2013 NCWM Annual Meeting: The Committee recommended this item be Withdrawn.

Additional letters, presentations and data may have been part of the Committee's consideration. Please refer to Appendix G of the *Report of the 97th National Conference on Weights and Measures* [SP 1160, 2012] to review these documents.

237-8 I Section 4.3. Dispenser Filters

This appeared as Informational Item 237-8 in the *Committee Reports for the 98th Annual Meeting* (NCWM Publication 16, 2013). At the 2013 NCWM Annual Meeting the Committee modified the status of this item to a Developing Item. This item is now identified at Item 270-4.

237-9 I Section 1. Definitions, Section 2. Standard Fuel Specifications, and Section 3. Classification and Method of Sale of Petroleum Items

Source:

Fuels and Lubricants Subcommittee Task Group (2012)

Purpose:

Update regulations related to flex fuels.

Item Under Consideration:

Section 1. Definitions

1.13. Denatured Fuel Ethanol. – ~~“Ethanol” as defined in Section 1.20. Ethanol. An ethanol blend component for use in gasoline-ethanol blends and Ethanol Flex Fuel. The ethanol is rendered unfit for beverage use by the addition of denaturants under formulas approved by the Alcohol and Tobacco Tax and Trade Bureau (TTB), www.ttb.gov. ASTM D4806, “Standard Specification for Denatured Fuel Ethanol for Blending with Gasolines for Use as Automotive Spark-Ignition Engine Fuel” describes the acceptable denaturants for denatured fuel ethanol to be blended into spark ignition engine fuels.~~
(Amended 20XX)

1.17. ~~E85 Fuel~~ Ethanol Flex Fuel. – ~~A blend~~ Blends of ethanol and hydrocarbons restricted for use as fuel in ground vehicles equipped with flexible-fuel spark-ignition engines, of which the ethanol portion is (nominally 75 to 85 volume percent denatured fuel ethanol).

(Amended 20XX)

1.20. Ethanol. – Also known as ~~“Denatured Fuel Ethanol,”~~ means nominally anhydrous ethyl alcohol meeting ASTM D4806 standards. It is intended to be blended with gasoline for use as a fuel in a spark-ignition internal combustion engine. The denatured fuel ethanol is first made unfit for drinking by the addition of the Alcohol and Tobacco Tax and Trade Bureau (TTB), www.ttb.gov, approved substances before blending with gasoline. “ethyl alcohol.” Ethanol is provided in gasoline-ethanol blends by blending denatured fuel ethanol. See Section 1.13. Denatured Fuel Ethanol.

(Amended 20XX)

1.53. Wholesale Purchaser Consumer. – Any person who is an ultimate ~~gasoline~~ consumer of gasoline, fuel methanol, Ethanol Flex Fuel, ~~fuel ethanol~~, diesel fuel, biodiesel, biodiesel blends, fuel oil, kerosene, aviation turbine fuels, natural gas, compressed natural gas, or liquefied petroleum gas and who purchases or obtains the product from a supplier and receives delivery of that product into a storage tank.

(Added 1998) (Amended 1999 and 20XX)

Section 2. Standard Fuel Specifications

2.7. Denatured Fuel Ethanol. – Intended for blending with gasoline shall meet the latest version of ASTM D4806, “Standard Specification for Denatured Fuel Ethanol for Blending with Gasolines for Use as Automotive Spark-Ignition Engine Fuel.”

2.10. Ethanol Flex Fuel ~~E85 Fuel~~ Ethanol. – ~~shall meet the latest version of the following ASTM D5798, “Standard Specification for Ethanol Fuel Blends for Flexible-Fuel Ethanol (Ed75-Ed85) for Automotive Spark-Ignition Engines.”~~ Ethanol Flex Fuel is covered by one of two ASTM standards based on the ethanol concentration of the blend:

- (a) Ethanol Flex Fuel containing 51 to 83 volume percent ethanol shall meet the latest version of ASTM D5798, “Standard Specification for Ethanol Fuel Blends for Flexible-Fuel Automotive Spark-Ignition Engines”; and
- (b) Ethanol Flex Fuel Blends containing 16 to 50 volume percent ethanol shall be blended, stored and conveyed for consumption in accordance with the latest version of ASTM D7794, “Standard Practice for Blending Mid-Level Ethanol Fuel Blends for Flexible-Fuel Vehicles with Automotive Spark-Ignition Engines”

(Added 1997) (Amended 20XX)

Section 3. Classification and Method of Sale of Petroleum Products

3.8. ~~E85 Fuel~~ Ethanol Flex Fuel-Blends.

3.8.1. How to Identify ~~E85 Fuel~~ Ethanol Flex Fuel. – Ethanol Flex Fuel Blends ethanol shall be identified as Ethanol Flex Fuel or EXX Flex Fuel ~~E85~~.

3.8.2. Labeling Requirements.

- (a) Ethanol Flex Fuel with an ethanol concentration no less than 51 and no greater than 83 volume percent shall be labeled “Flex Fuel, minimum 51 % ethanol.” Fuel ethanol shall be labeled with its automotive fuel rating in accordance with 16 CFR Part 306.
- (b) Ethanol Flex Fuel with an ethanol concentration less than or equal to 50 volume percent shall be labeled “EXX Flex Fuel, minimum YY % ethanol”, where the XX is the ethanol

concentration in volume percent and YY is XX minus 5. The actual ethanol concentration of the blend shall be XX volume percent plus or minus 5 volume percent.

~~(c)(b)~~—A label shall be posted which states “For Use in Flexible Fuel Vehicles (FFV) Only.” This information shall be clearly and conspicuously posed on the upper 50 % of the dispenser front panel in a type at least 12.7 mm (½ in) in height, 1.5 mm (1/16 in) stroke (width of type). A label shall be posted which states, **“CHECK OWNER’S MANUAL”, in 20 point font “Consult Vehicle Manufacturer Fuel Recommendations,” and shall not be less than 6 mm (¼ in) in height by 0.8 mm (1/32 in) stroke; block style letters** and the color shall be in definite contrast to the background color to which it is applied.

(Amended 2007, ~~and 2008,~~ **and 20XX**)

Section 4. Retail Storage Tanks and Dispenser Filters

4.1. Water in Gasoline-Alcohol Blends, Biodiesel Blends, ~~E85 Fuel~~ Ethanol Flex Fuel Blends, Aviation Gasoline, and Aviation Turbine Fuel. – No water phase greater than 6 mm (¼ in) as determined by an appropriate detection paste or other acceptable means, is allowed to accumulate in any tank utilized in the storage of gasoline-alcohol blend, biodiesel, biodiesel blends, ~~E85 Fuel~~ **ethanol flex fuel blends**, aviation gasoline, and aviation turbine fuel.

(Amended 20XX)

4.2. Water in Gasoline, Diesel, Gasoline-Ether, and Other Fuels. – Water shall not exceed 25 mm (1 in) in depth when measured with water indicating paste or other acceptable means in any tank utilized in the storage of diesel, gasoline, gasoline-ether blends, and kerosene sold at retail except as required in Section 4.1. Water in Gasoline-Alcohol Blends, Aviation Blends, Biodiesel Blends, ~~E85 Fuel~~ **Ethanol Flex Fuel Blends**, Aviation Gasoline, and Aviation Turbine Fuel.

(Amended 2008, ~~and 2012,~~ **and 20XX**)

4.3. Dispenser Filters.

4.3.1. Engine Fuel Dispensers.

- (a) All gasoline, gasoline-alcohol blends, gasoline-ether blends, ~~E85 fuel~~ **Ethanol Flex Fuel ethanol**, and M85 methanol dispensers shall have a 10 micron or smaller nominal pore-sized filter.
- (b) All biodiesel, biodiesel blends, diesel, and kerosene dispensers shall have a 30 micron or smaller nominal pore-sized filter.

(Added 2008) **(Amended 20XX)**

Background/Discussion:

The current wording in NIST Handbook 130 related to fuels restricted to use in Flex Fuel Vehicles should be reviewed. Input gathered from the regional meetings and other stakeholders will be utilized by FALS to develop recommended modifications to NIST Handbook 130.

2011 CWMA and NEWMA Interim Meeting: There were no comments. CWMA and NEWMA forwarded the item to NCWM recommending it as a Developing Item while FALS continues its work.

2011 WWMA Annual Meeting: WWMA forwarded the item to NCWM recommending it as an Informational Item while FALS continues its work.

2011 SWMA Annual Meeting: Mr. Chuck Corr, Chair of the Task Group (TG) under the FALS, gave a presentation on the topic. FALS TG identified several areas where stakeholder input is needed to propose updates to NIST Handbook 130 and to reflect new language in ASTM D5798. No comments were made during the hearing. FALS is expected to have a recommendation for the Interim Meeting. SWMA forwarded the item to NCWM recommending it as a Developing Item.

2012 NCWM Interim Meeting: The Committee received updates on the TG's progress. Mr. Corr will lead an effort to get regional input on a transition and implementation date. The 2012 L&R Committee designated this item as an Informational Item.

2012 NEWMA Annual Meeting: There were no comments. NEWMA recommended that the item remain as an Informational Item.

2012 CWMA Annual Meeting: Mr. Corr gave a presentation on "Flex Fuel Task Force Update" (Flex Fuel Task Group Update). This presentation noted that ASTM standards D7794-12 and D5798-11 cover the standard for a full range of ethanol concentrations. Several commented that the 51 % to 83 % range is too broad. A regulatory official was concerned with blends at the pumps. They can blend and percentage they choose. A stakeholder remarked that consumers are concerned with price and miles per gallon (MPG) and may not have enough knowledge in regards to blends. Another stakeholder remarked that ASTM 5798 is at the terminal and the Conference needs to address this issue. CWMA recommended that the item remain as an Informational Item and that FALS continues its development.

2012 NCWM Annual Meeting: Mr. Corr reported on behalf of FALS TG that approximately 18 areas of NIST Handbook 130 have been identified where modifications may be needed. A stakeholder voiced full support of the TG efforts. Mr. Corr's group will report again at the 2013 NCWM Interim Meeting.

2012 CWMA Interim Meeting: The FALS Task Group chair gave a presentation and would like to present an item to the NCWM L&R that would be ready for voting status at the 2013 NCWM Annual Meeting. He asked for input from regulators on a generic name for flex fuel vehicle fuel, names for individual blends, and labels for blends. The CWMA supports this item and recommends that it remain an Information Item for further development by the FALS TG.

2012 WWMA Annual Meeting: Mr. Corr provided an update on behalf of FALS. Mr. Corr stated that information will be fully developed and released prior to the 2013 NCWM Interim Meeting. The Committee would like to review that information. WWMA recommended that the item be an Informational Item.

2012 SWMA Annual Meeting: Mr. Corr commented as chair of the Fuels and Lubricants Subcommittee Task Group that the group is working on language to reflect to reflect the new ASTM D7794 and recently modified D5798 standards for fuels restricted to flex fuel vehicles. It should be available for review at the Interim. Mr. Russ Lewis (Marathon Petroleum) gave a presentation in support of the proposal, taking into account the recently modified ASTM D5798 "Specifications for Ethanol Fuel Blends for Flexible Fuel Automotive Spark Ignition Engines". Russ provided a copy of newly proposed language to the TG for consideration. SWMA recommended that the item be an Informational Item.

2012 NEWMA Interim Meeting: NEWMA recommended that the item be an Informational Item.

2013 NCWM Interim Meeting: Mr. Corr provided an update of the language changes he is recommending for addressing the full range of fuels restricted to flex fuel vehicles in NIST Handbook 130. Mr. Corr commented that no feedback has been provided to him from stakeholders and states concerning the language changes. Mr. Corr also remarked that the FALS has also not reviewed and discussed the proposed changes. The Committee recommended this as an Informational Item so that interested parties can provide comments.

2013 CWMA and NEWMA Annual Meetings: Both Associations support the on-going work being done by the TG on this item. Both Associations recommend this move forward as an Informational Item.

2013 NCWM Annual Meeting: Mr. Corr provided initial language changes for a Uniform Regulation for the Method of Sale, Section 2.30. ~~E85 Fuel~~ Ethanol Flex Fuel Blends. This language has been placed under the Method of Sale of Commodities and appears as Item 232-6.

Additional letters, presentations and data may have been part of the Committee's consideration. Please refer to Appendix J, *Report of the 97th National Conference on Weights and Measures* [SP 1160, 2012] to review these documents.

260 NIST HANDBOOK 133

260-1 V Section 2.3.8. Moisture Allowance – Pasta Products

(This item was adopted.)

Source:

Southern Weights and Measures Association (2010)

Purpose:

Establish a moisture allowance for macaroni, noodle, and like products (pasta products).

Item Under Consideration:

Amend NIST Handbook 133 as follows:

2.3.8. Moisture Allowances

When no predetermined allowance is found in NIST Handbook 133, the potential for moisture loss must be considered. Inspectors should follow their jurisdiction's guidance for making their determination on an acceptable moisture allowance.

(Added 2010)

If the product tested is subject to moisture loss, provide for the moisture allowance by following one of the two procedures listed below.

2.3.8.1. Applying Moisture Loss before Determining Package Errors

1. Determine the percent value of the moisture allowance if the product is listed below. (See Table 2-3. "Moisture Allowances")

Table 2-3. Moisture Allowances		
Verifying the labeled net weight of packages of:	Moisture Allowance is:	Notes
Flour	3 %	
Dry pet food	3 %	Dry pet food means all extruded dog and cat foods and baked treats packaged in Kraft paper bags and/or cardboard boxes with a moisture content of 13 % or less at time of pack.
<u>Pasta Products</u>	<u>3 %</u>	<u>Pasta products means all macaroni, noodle, and like products packaged in Kraft paper bags, paperboard cartons, and/or flexible plastic bags with a moisture content of 13 % or less at the time of pack.</u>
Borax	See Section 2.4.	
Wet Tare Only¹		
Fresh poultry	3 %	Fresh poultry is defined as poultry above a temperature of – 3 °C (26 °F) that yields or gives when pushed with the thumb.
Franks or hot dogs	2.5 %	
Bacon, fresh sausage, and luncheon meats	0 %	For packages of bacon, fresh sausage, and luncheon meats, there is no moisture allowance if there is no free-flowing liquid or absorbent material in contact with the product and the package is cleaned of clinging material. Luncheon meats are any cooked sausage product, loaves, jellied products, cured products, and any sliced sandwich-style meat. This does not include whole hams, briskets, roasts, turkeys, or chickens requiring further preparation to be made into ready-to-eat sliced product. When there is no free-flowing liquid inside the package and there are no absorbent materials in contact with the product, Wet Tare and Used Dried Tare are equivalent.
<p>¹Wet tare procedures must not be used to verify the labeled net weight of packages of meat and poultry packed at an official United States Department of Agriculture (USDA) facility and bearing a USDA seal of inspection. The Food Safety and Inspection Service (FSIS) adopted specific sections of the 2005 4th edition of NIST HB 133 by reference in 2008 but not the “Wet Tare” method for determining net weight compliance. FSIS considers the free-flowing liquids in packages of meat and poultry products, including single-ingredient, raw poultry products, to be integral components of these products (see Federal Register, September 9, 2008, [Volume 73, Number 175] [Final Rule – pages 52189-52193]).</p>		

(Amended 2010 **and 2013**)

Note: There is no moisture allowance when inspecting meat and poultry from a USDA inspected plant when Used Dry Tare and “Category A” sampling plans are used.

Note: For the Wet Tare Only section of Table 2-3, free-flowing liquid and liquid absorbed by packaging materials in contact with the product are part of the wet tare.

(Added 2010)

2. To compute moisture allowance, multiply the labeled quantity by the decimal percent value of the allowance. Record this value in Box 13a.

Example:

Labeled net quantity of flour is 907 g (2 lb)

Moisture Allowance is 3 % (0.03)

Moisture Allowance = 907 g (2 lb) x 0.03 = 27 g (0.06 lb)

3. If the Moisture Allowance is known in advance (e.g., flour, **pasta products** and dry pet food), it can be applied by adjusting the Nominal Gross Weight used to determine the sample package errors. The Moisture Allowance in Box 13a is subtracted from the Nominal Gross Weight to obtain an Adjusted Nominal Gross Weight which is entered in Box 14. The Nominal Gross Weight is defined in Section 2.3.6.1. as the sum of the Labeled Weight and the Average Tare Weight from Box 13.

Example:

Use a Labeled Weight of 907 g (2 lb) and an Average Tare Weight of 14 g (0.03 lb)

The calculation is:

Labeled Net Quantity of Contents 907 g (2 lb) + Average Tare Weight 14 g (0.03 lb) = 921 g (2.03 lb) – Moisture Allowance 27 g (0.06 lb) = Adjusted Nominal Gross Weight of 894 g (1.97 lb)

This result is entered in Box 14.

4. Determine package errors by subtracting the Adjusted Nominal Gross Weight from the Gross Weights of the Sample Packages.

Example:

The calculation is:

Gross Weight of the Sample Packages – Adjusted Nominal Gross Weight = Package Error

Note: When the Nominal Gross Weight is adjusted by subtracting the Moisture Allowance value(s) the Maximum Allowable Variation (s) is not changed. This is because the errors that will be found in the sample packages have been adjusted by subtracting the Moisture Allowance (e.g., 3 %) from the Nominal Gross Weight. That increases the individual package errors by the amount of the moisture allowance (e.g., 3 %). If the value(s) of the MAV(s) were also adjusted it would result in doubling the allowance. MAV is always based on the labeled net quantity.

(Added 2010)

2.3.8.3. Moisture Allowance Gray Area

When the average error of a lot of fresh poultry, franks, or hot dogs, **pasta products** is minus but does not exceed the established “moisture allowance” or “gray area,” contact the packer or plant management personnel to determine what information is available on the lot in question. Questions to the plant management representative may include:

- Is a quality control program in place?

- What information is available concerning the lot in question?
- If net weight checks were completed, what were the results of those checks?
- What adjustments, if any, were made to the target weight?

Note: If the plant management has data on the lot, such data may help to substantiate that the “lot” had met the net content requirements at the point of manufacture.

This handbook provides “moisture allowances” for some meat and poultry products, flour, **pasta products**, and dry pet food. These allowances are based on the premise that when the average net weight of a sample is found to be less than the labeled weight, but not by an amount that exceeds the allowable limit, either the lot is declared to be within the moisture allowance or further investigation can be conducted.

Reasonable variations from net quantity of contents caused by the loss or gain of moisture from the package are permitted when caused by ordinary and customary exposure to conditions that occur under good distribution practices. If evidence is obtained and documented to prove that the lot was shipped from the packaging plant in a short-weight condition or was distributed under inappropriate or damaging distribution practices, appropriate enforcement action should be taken.

Background/Discussion:

Studies indicate that moisture loss for pasta products is reasonably predictable over time. Pasta exhibits consistent moisture loss in all environments and packaging, which can vary more than 4 % due to environmental and geographic conditions. Although it eventually reaches equilibrium with the surrounding atmosphere, because it is hygroscopic, this balance does not occur until long after packaging and shipping.

2010 Interim Meeting: The Committee heard support for this item from industry and stakeholders. This item would amend the Moisture Allowance Table in NIST Handbook 133 giving pasta a 3 % moisture allowance. The Committee reviewed the submitted study (refer to the *Report of the 95th National Conference on Weights and Measures* [SP 1115, 2010]). The 2010 L&R Committee designated this item as a Voting Item.

2010 NEWMA Annual Meeting: A representative of the pasta industry gave the group an explanation of the item and expressed support for this item as written. NEWMA also supported this item.

2010 CWMA Annual Meeting: A representative from the National Pasta Association (NPA) stated the data supports the 3 % moisture allowance. An official commented that testing in their state does not support the proposal. An industry representative stated that guidance is needed for an established moisture allowance and currently there are no guidelines to establish the moisture loss percentage.

2010 NCWM Annual Meeting: A representative for the NPA spoke on behalf of the proposal. This item would allow for a specific moisture loss percentage to be taken. Inspectors would have a specific number that they can apply to the pasta product. Representatives of several pasta companies spoke in support of this item stating that it is consistent with numerous studies that have been done. An official opposed this item since pasta is known to have moisture loss due to the type of product it is. He further explained that applying a blanket 3 % moisture loss does not make sense, what may be good in Florida may not be good in New Mexico. Another official stated that applying the 3 % does not stop an inspector from going into a distribution or point of pack to inspect; especially if the inspectors believe the packer is under filling packages. He urged that this proposal be supported to provide a tool. Another official voiced support because it is important to recognize guidelines for consideration. A pasta association representative also agreed that this work goes back a couple of decades and several studies were provided for consideration. Another representative explained that they pack to net weight. Pasta contains 10 % to 13 % moisture; if the moisture standard is lowered the product falls apart along with the product quality. There was a split vote on this item at the 2010 Annual Meeting, and it was returned to the Committee.

2010 CWMA Interim Meeting: An official provided information regarding informal testing of pasta products in their state. The concern is that pasta can gain moisture as well as lose moisture; therefore, they oppose a national

moisture allowance for pasta products. It was further explained that moisture loss/gain seems to be dependent upon the type of packaging used. This official also commented that product is no longer warehoused for long periods of time, and it is mostly in climate controlled stores, which would prevent the need for a moisture allowance. Another official agreed that a national standard may not be appropriate due to humidity differences from state to state. CWMA recommended that the item be Withdrawn.

2010 WWMA Annual Meeting: An official expressed support for adopting a 3 % moisture allowance for pasta citing the significant work done and data provided by the NPA. The Committee recommended that any additional data from studies be provided for review. WWMA recommended that the item remain as a Voting Item.

2010 SWMA Annual Meeting: There were no comments on this item. SWMA recommended that the item be Withdrawn; however, if further studies are developed, then this should be taken into consideration.

2010 NEWMA Interim Meeting: Attendees expressed strong reservations about this proposal. Comments were heard regarding industry practices in regards to moisture loss when packing and if there is a need to codify the moisture loss allowance at all. A member commented that if this proposal passed, other industries would now approach the Conference and ask for specific moisture allowances for their products. NEWMA recommended that the item be Withdrawn.

2011 NCWM Interim Meeting: An overview was presented by the NPA regarding the history and studies that have been performed in regard to moisture loss of pasta. Pasta is a hygroscopic product and changes in moisture content in the product may occur in the package due to atmospheric changes (refer to Appendix I, *Report of the 96th National Conference on Weights and Measures* [SP 1125, 2011]). Hot, dry, and air conditioned store environments have less humidity and will pull moisture from the product. Conversely, in tropical, wet and high humidity environments (seldom seen in U.S. stores) the product will pull moisture in. According to Ms. Hoover (American Italian Pasta Company), companies do pack to the law and have documented weight control programs. The 2011 L&R Committee designated this item as a Voting Item.

2011 NCWM Annual Meeting: The NPA gave a presentation with background information and a brief legal overview on moisture loss. NPA also distributed a page with frequently asked questions and a follow-up study (refer to Appendix I, *Report of the 96th National Conference on Weights and Measures* [SP 1125, 2011]) that occurred in 2006 - 2007 that shows a 2.5 % to 5 % moisture loss. Pasta consists of flour and water. Handbook 133 stipulates a 3 % moisture allowance for flour. Pasta is packaged in either breathable film or paperboard cartons. This allows for the pasta to breathe and not mold. The industry is requesting that this proposal be adopted by the Conference to give officials the guidance that is needed when performing inspections. On a split Vote this item was returned to the Committee.

2011 CWMA Interim Meeting: An industry representative stated that a uniform procedure for moisture loss is needed. Although difficult, we can develop a surrogate that can be easily used by manufacturers and easily verified by weights and measures and recommended this item be Withdrawn. The Committee disagreed and believes that moisture loss is a legitimate issue and deserves consideration by NCWM. CWMA recommended that the item remain as a Voting Item.

2011 WWMA Annual Meeting: A state official requested additional information concerning good manufacturing and distribution processes. The Committee firmly believed that enough data had been established by industry to address questions regarding moisture allowances with pasta and pasta products. WWMA recommended that the item remain as a Voting Item.

2011 NEWMA Interim Meeting: NEWMA continued to oppose this item. NEWMA recommended that the item be Withdrawn.

2011 SWMA Annual Meeting: No comments were heard. The Committee noted that it appears as if proper protocol has been followed by the pasta industry. If states do not support the item, SWMA recommends that they provide the reasons so their issue(s) can be addressed. SWMA recommended that the item remain as a Voting Item.

2012 NCWM Interim Meeting: The Committee reviewed documents received from the NPA. A representative with the American Italian Pasta Company supported the language as presented. An official who has an active package inspection program remarked that a significant amount of data has been provided by the NPA. The 2012 L&R Committee designated this item as a Voting Item.

2012 NEWMA Annual Meeting: Ms. Jayne Hoover (American Italian Pasta Company) gave a presentation on the development of this topic and the extensive national testing and data collection which was done. One member indicated that it was a good objective and did not see a reason to oppose it. Several others voiced their historical opposition to moisture allowance. On a split vote, NEWMA recommended that the item remain as a Voting Item.

2012 CWMA Annual Meeting: A representative from the NPA and American Italian Pasta Company addressed the top five frequently asked questions which are: 1) 3 % gray area (gray area is not a tolerance), 2) current data on product (2006 - 2007 study of over 700 samples), 3) why 3 %, 4) what causes variability (there are over 500 shapes of pasta and 3000 SKUs), and 5) regulatory standardization. Three regulatory officials spoke in opposition to the item. Several others spoke in favor, commenting that officials are required to recognize reasonable moisture loss and pasta rehydrates during cooking so there is no loss to the consumer. One regulator asked for clarification on why moisture loss appears to level out at six months. The NPA representative explained that different pastas have different moisture loss due to their shapes and size. CWMA recommended that the item remain as a Voting Item.

2012 NCWM Annual Meeting: Ms. Hoover provided an overview on gray area, current data, and variability. She stressed the need for uniformity in the marketplace. A nother pasta representative remarked that Congress established that it is important to keep in mind the gray area. The gray area is not a tolerance and moisture loss does not cause the product to be short weight. Several regulatory officials spoke in support of this item. Two spoke in opposition, noting that moisture loss should be dealt with on a case-by-case basis. On a split vote, the item was returned to the Committee.

2012 CWMA Interim Meeting: A regulatory official recommended withdrawing the item. It has been voted on twice at NCWM, and both votes were split votes. Another recommended it be a Voting Item because some states did not realize that abstaining from the vote was tantamount to a no vote. No CWMA officials planned to change their vote. Another official recommended that it move forward as a Voting Item, stating that the industry had submitted a complete proposal that justified the moisture allowance. The item was fully developed with supporting data that justified the moisture allowance. Those states that abstained in the 2012 NCWM meeting should be given an opportunity to vote on this item. CWMA supported the item and recommended that the item be a Voting Item.

2012 WWMA Annual Meeting: Five regulatory officials commented in support of the item. NPA has met all requests to provide documented data that supported initial studies on moisture loss. The data demonstrated that a 3 % moisture allowance is appropriate. Under federal law moisture loss must be recognized and adoption of this item would provide a moisture allowance for inspectors when testing pasta products. Comments stressed that a moisture allowance should be adopted to provide guidance to the pasta industry and to regulatory officials regarding package content compliance testing and enforcement. No evidence or data has been presented at any of the regional associations and NCWM meetings to contradict NPA's data presented. The Committee recognized the cooperation by the pasta industry members to comply with NCWM's request to demonstrate the appropriateness of the proposed 3 % moisture allowance. The Committee supported the item, but expressed concern that it has not advanced because of a split vote for several years. The Committee suggested that the NCWM L&R Committee make this a priority item for the Moisture Allowance Work Group. In addition to the NPA study data, the Committee would have preferred an independent study from outside sectors. The Committee recognizes that additional data and studies may be available. If there is other data available that contradicts or supports NPA's data, individuals are urged to submit it to the NCWM for consideration. WWMA recommended that the item be a Voting Item.

2012 SWMA Annual Meeting: The Committee believed the pasta industry has presented the necessary data needed by the NCWM to make a decision. SWMA recommended that the item be a Voting Item.

2012 NEWMA Interim Meeting: NEWMA members stated that sufficient work has been done on this topic and that more than enough data has been submitted to support the proposal. NEWMA members who had previously opposed the item stated that it now has their support. NEWMA recommended that the item be a Voting Item.

2013 NCWM Interim Meeting: Ms. Maile Hermida (Hogan Lovells, US, LLP) remarked that the NPA supports this item due to the strong underlying data that supports the proposal. Mr. Kurt Floren (Los Angeles County, California) commented that this item remained on the agenda due to a split vote at the 2012 NCWM Annual Meeting. Under federal law you must allow for reasonable moisture loss. Mr. Floren would like to hear the reasons as to why states oppose this item. Several states spoke up in support of the item. The Committee recommends this as a Voting item.

2013 CWMA Annual Meeting: A state regulator provided data on a study performed by his state which corroborates evidence that a moisture reduction of 3 % is reasonable. The Committee believes the data presented by industry and the state supports the 3 % grey area. The Committee recommends this be a Voting Item.

2013 NEWMA Annual Meeting: The Committee believes that sufficient work has been done and supports this item as a Voting Item.

2013 NCWM Annual Meeting: There was testimony heard during open hearings stating there is support to move this item forward. The Committee recommended the item be presented for a Vote as shown in the Item Under Consideration.

Additional letters, presentations and data may have been part of the Committee's consideration. Please refer to Appendix K, *Report of the 97th National Conference on Weights and Measures* (SP 1160, 2012) to review these documents.

260-2 V Section 3.10. Animal Bedding

This appeared as Voting Item 260-2 in the *Committee Reports for the 98th Annual Meeting* (NCWM Publication 16, 2013). At the 2013 NCWM Annual Meeting the Committee modified the status of this item to a Developing Item. This item is now identified as Item 270-6.

260-3 W Gravimetric Testing of Printer Ink and Toner Cartridges

(This item was withdrawn.)

Source:

WWMA (2013)

Purpose:

Provide a test procedure in NIST Handbook 133 for gravimetric testing of printer ink and toner cartridges.

Item Under Consideration:

None.

Background/Discussion:

The Laws and Regulations Committee received a proposal in 2010 to create a uniform method of sale for printer ink and toner cartridges. See the related item in the 232 Series of this report for more detail and background discussion.

A Task Group was formed to address the method of sale, but was unable to reach consensus. In 2012, the Task Group was replaced with a new one that was charged to develop Handbook 133 gravimetric test procedures to verify net contents of ink and toner cartridges. The Committee agreed to keep the original Method of Sale item as an Informational Item until the second Task Group completes its recommendations.

2012 WWMA Annual Meeting: Mr. Paul Jeran expressed concern with the concept of providing a tare weight on package labels because his company has over 30 million items and believes the test method under consideration may not be appropriate. In reviewing the background discussion of the 232 Series Method of Sale Item, the Committee recommends that NCWM give careful consideration to industry concerns. WWMA recommended that the item remain as a Developing Item.

2013 NCWM Interim Meeting: Ms. Judy Cardin, Printer Ink and Toner Cartridge Gravimetric Package Testing Task Group Chair provided a presentation on the work of the task group (refer to Item 232-4). Ms. Cardin also provided a marketplace survey that reflected “count” was the most common quantity statement being used. It was requested of industry the feasibility to place the tare weight on cartridges. This was not practicable due to cartridge parts being manufactured domestically and internationally and may not always be made of the same material. The presentation also reflected an in-house test using a gravimetric procedure. It was determined by the Task Group that there is not a practical test procedure. The L&R Committee Withdrew this item in its entirety.

Additional letters, presentations, and data may have been part of the Committee’s consideration. Please refer to Appendix C, *Report of the 97th National Conference on Weights and Measures* (SP 1160, 2012) to review these documents.

260-4 V Section 4.3. Paper Plates and Sanitary Paper Products

This appeared as Voting Item 260-4 in the *Committee Reports for the 98th Annual Meeting* (NCWM Publication 16, 2013). At the 2013 NCWM Annual Meeting, the Committee modified the status of this item to a Developing Item and is now identified as Item 270-5.

270 OTHER ITEMS – DEVELOPING ITEMS

The Committee Chair has the discretion as to whether or not to take comments on Developing Items during Committee open hearings based on factors such as the amount of time remaining to cover Committee Agenda item.

270-1 D Fuels and Lubricants Subcommittee

Source:

The Fuels and Lubricants Subcommittee (2007)

Purpose:

Update the Uniform Engine Fuels, Petroleum Products, and Automotive Lubricants Regulation in NIST Handbook 130 including major revisions to fuel ethanol specifications. Another task will be to update the Basic Engine and Fuels, Petroleum Products, and Lubricants Laboratory Publication.

Item Under Consideration:

This item is under development. All comments should be directed to Mr. Ronald Hayes, FALS Chair, at (573) 751-4316, ron.hayes@mda.mo.gov, or Mr. David Sefcik, NIST Technical Advisor at (301) 975-4868, dsfcik@nist.gov.

Background/Discussion:

The Subcommittee met on January 24, 2007, at NCWM Interim Meeting to undertake a review of a number of significant issues related to fuel standards. Their first project was to undertake a major review and update of the Uniform Engine Fuels, Petroleum Products, and Automotive Lubricants Regulation in NIST Handbook 130. The Subcommittee also met at the 2007 NCWM Annual Meeting and continued its work on a number of items in addition to preparing a major revision of the Fuel Ethanol Specifications.

An additional project will be to update and possibly expand the Basic Engine Fuels, Petroleum Products, and Lubricants Laboratory Publication. The Subcommittee will undertake other projects as time and resources permit.

Additional background/history, letters, presentations, and data may have been part of the Committee’s consideration. Please refer to Laws and Regulations Committee, *Report of the 97th National Conference on Weights and Measures* (SP 1160, 2012) to review these documents.

270-2 D Packaging and Labeling Subcommittee

Source:

Packaging and Labeling Subcommittee (2011)

Purpose:

Provide notice of formation of a new Subcommittee reporting to the L&R Committee.

Item Under Consideration:

None

Background/Discussion:

2011 NCWM Interim Meeting: The PALS met for the first time to discuss ongoing issues and agenda items in regards to packaging and labeling regulations. There were 11 attendees that represented industry, state and county regulatory officials, and the NIST Technical Advisor.

The mission of PALS is to assist the L&R Committee in the development of agenda items related to packaging and labeling. The Subcommittee will also be called upon to provide important and much needed guidance to the regulatory and consumer packaging communities on difficult questions. PALS will report to NCWM L&R Committee. The NIST Technical Advisor reported that FTC will do a review of FPLA in 2013. The 2011 L&R Committee designated this item as a Developing Item and assigned its development to PALS.

2011 CWMA Interim Meeting: The PALS Chair stated the goal is to be active before the 2012 NCWM Interim meeting and stated there is a need to prioritize labeling issues. No action was needed. CWMA recommended that the item remain as a Developing Item.

2012 NCWM Interim Meeting: PALS met to discuss its formation and strategy. The NCWM Chairman will appoint eight voting members on the Committee to consist of four regulatory officials (one from each region) and four from industry (two retailers and two manufacturers). Mr. Christopher Guay (Procter and Gamble), PALS Chair, reported that work will be done through webinar meetings to be held approximately four times a year. PALS members will be responsible for providing updates at their regional meetings and to seek input into issues. Mr. Guay added that PALS will be developing proposals and providing guidance and recommendations on existing proposals as assigned by the NCWM L&R Committee. He also stressed the need and importance of having key federal agencies (FDA, FTC, and USDA) participating. The NIST Technical Advisor commented that FTC announced that they will review the FPLA in 2013. The 2012 L&R Committee designated this item as a Developing Item and assigned its development to PALS.

2012 NCWM Annual Meeting: Mr. Guay reported the Subcommittee is considering further development of the following items:

- **Additional Net Content Declarations on the Principal Display Panel** – Package net contents are most commonly determined by the product form, for example, solid products are labeled by weight and liquid products are labeled by volume. Semi-solid products such as pastes, creams and viscous liquids are required to be labeled by weight in the United States and by volume in Canada.
- **Icons in Lieu of Words in Packaged labeled by Count** – Can a clear and non-misleading icon take the place of the word “count” or “item name” in a net content statement? While existing Federal regulation requires regulatory label information to be in “English,” the increasing presence of multilingual labels and the growing diversity of the U.S. population suggest more consumers are served with a clear and non-misleading icon.
- **Multilingual Labels**
- **Multipacks and Bundle Packages** – The net content statements for multipacks and bundled packages of individually labeled products can be different based on the approach used to calculate them. The difference

is the result of the degree of rounding for dual inch-pound and metric declarations. Using two apparently valid but different methods can yield one net content statement result that provides more accuracy between the metric and inch-pound declarations and a different net content result, which is consumer friendly.

2012 SWMA Annual Meeting: Mr. Guay stated Item 231-1 has been assigned to PALS for a recommendation. PALS is working on a series of principles and recommendations regarding claims and statements made on packages outside of quantity statement (i.e., supplemental, quality, and performance claims) on what is appropriate and what is not. PALS will recommend that Item 231-1 be Withdrawn. PALS is also looking at whether icons are appropriate as part of a quantity statement and how labeling of products with multilingual labels can be simplified. SWMA recommended that the item remain as a Developing Item.

2013 NCWM Interim Meeting: Mr. James Kohm (Director of Enforcement at the Federal Trade Commission [FTC]), briefed NCWM on the goals and objectives of FTC. Mr. Kohm gave a general overview of the Fair Packaging and Labeling Act (FPLA) and announced that it is under review in 2013.

Mr. Guay provided an update on the action of PALS. PALS will be focusing on best practice principles for the various quantity and quality statements seen in the marketplace. PALS will also continue to work on the items addressed at the 2012 Annual Meeting.

Additional letters, presentations, and data may have been part of the Committee's consideration. Please refer to *Report of the 97th National Conference on Weights and Measures* (SP 1160, 2012) to review these documents.

270-3 D Moisture Allowance Task Group (MATG)

Source:

Moisture Allowance Task Group (2012)

Purpose:

Provide notice of formation of a new Task Group reporting to the Committee. This Task Group will provide additional guidance for making moisture allowances for products not listed in NIST Handbook 133.

Item Under Consideration:

None

Background/Discussion:

2012 NCWM Interim Meeting: Ms. Judy Cardin, Committee Chair, will be requesting that the NCWM Board of Directors form a new Task Group to review moisture allowance. The 2012 L&R Committee designated this item as a Developing Item.

2012 NCWM Annual Meeting: Mr. Kurt Floren (Los Angeles County, California) announced that he will Chair the Moisture Allowance Task Group.

2012 WWMA Annual Meeting: Mr. Floren remarked that he is actively seeking individuals with expertise in moisture allowance. WWMA recommended that the item remain as a Developing Item.

2012 SWMA Annual Meeting: The Committee supported the formation of the Moisture Loss Work Group. SWMA recommended that the item remain as a Developing Item.

2013 NCWM Interim Meeting: Kurt Floren, MATG Chairperson announced that he is still seeking a representative from each region for the MATG. He would prefer to have a representative from each region. Currently the following have regions have provided a representative; NEWMA, Frank Greene, (Connecticut) and WWMA, Mr. Brett Gurney (Utah). The following individuals have also expressed interest: Ms. Maile Hermida (Hogan Lovells US, LLP), Ms. Ann Boeckman (Kraft Foods Group), Mr. Pete O'Bryan (Foster Farms), Mr. Chris Guay (Procter and Gamble Co.). Mr. Floren remarked that meetings will be held via web-meetings and at the NCWM Conferences.

Anyone interested in assisting with the work should contact Mr. Kurt Floren, Moisture Allowance Task Group (MATG) Chairperson at (626) 575-5451 or kfloren@acwm.lacounty.gov or Ms. Lisa Warfield, NIST Technical Advisor at (301) 975-3308 or lisa.warfield@nist.gov.

Additional letters, presentations, and data may have been part of the Committee's consideration. Please refer to *Report of the 97th National Conference on Weights and Measures* (SP 1160, 2012) to review these documents.

270-4 D Handbook 130, Engine Fuels and Automotive Lubricants, Section 4.3. Dispenser Filters

This appeared as Informational Item 237-8 in the *Committee Reports for the 98th Annual Meeting* (NCWM Publication 16, 2013).

Source:

Missouri Department of Agriculture (2012)

Purpose:

Recognize the need for 10-micron or smaller nominal pore-sized filters for today's diesel engines.

Item Under Consideration:

4.3. Dispenser Filters.

4.3.1. Engine Fuel Dispensers.

- (a) All gasoline, gasoline-alcohol blends, gasoline-ether blends, biodiesel, biodiesel blends, diesel, E85 fuel ethanol, and M85 methanol dispensers shall have a 10 micron or smaller nominal pore-sized filter.
- (b) All ~~biodiesel, biodiesel blends, diesel, and~~ kerosene dispensers shall have a 30 micron or smaller nominal pore-sized filter.

Background/Discussion:

Abnormal dispenser filter plugging at retail will alert the retailer of potential storage tank problems. Requiring 10-micron filters for all products will reduce the inventory and the potential of installing the wrong filter for all products at the same site.

2011 CWMA Interim Meeting: An official commented that a smaller porosity filter may be acceptable but for now this is a reasonable start. CWMA forwarded the item to NCWM recommending it as a Voting Item.

2011 WWMA Annual Meeting: Need was expressed for more technical information and there were concerns that the flow rate would be diminished, the size of the filter may need to increase, and coupled with biodiesel it would tend to clog the filter in colder climates. Because of these reasons the Committee did not believe there was sufficient data to justify addressing this issue. WWMA did not forward the item to NCWM and recommended that the submitter provide additional studies and technical documents to support this proposal.

2011 NEWMA Interim Meeting: Questions were raised as to whether or not "measurement" of filter content was within the ability of weights and measures officials. It was noted that better filters may enhance fuel quality. The Committee believes that the proposal has potential, given input from industry and NCWM members. NEWMA forwarded the item to NCWM recommending it as a Developing Item.

2011 SWMA Annual Meeting: An industry representative stated that standard retailer dispensers use a 10-micron filter, and high capacity dispensers use 30-micron filters (i.e., diesel dispensed at truck stops). The company's engineers have determined that reducing a 30-micron filter to a 10-micron filter will drastically reduce flow rate to trucks. Another industry representative agreed and re-iterated that truck stops would see a tremendous reduction in flow. The Committee believed this proposal was not practical and would have a negative impact and undue burden on the trucking industry. SWMA did not forward the item to NCWM.

2012 NCWM Interim Meeting: Mr. Ron Hayes, FALS Chair, informed the Committee that FALS recommended that this item be Informational because of industry concerns that 10-micron filters would be too restrictive of flow in high-flow systems. One industry representative expressed opposition for the use of 10-micron filters and recommends this item to be Withdrawn. A representative of an automobile manufacturer claimed diesel passenger vehicles do not have the sophisticated filtration systems commonly found on commercial duty vehicles and 10-micron filters on dispensers are needed for protection from particulate contamination. As proposed, this item could cause clogging of diesel dispenser filters in colder climates. The Committee believes this item has merit but lacks a consensus and also believes that FALS needs to address these concerns. The 2012 L&R Committee designated this item as an Informational Item and assigned it to FALS for further development.

2012 NCWM Interim Meeting: It was apparent to the Committee that that there are many unresolved issues related to passenger vehicles. The Committee encourages the FALS to continue developing this item.

2012 NEWMA and CWMA Annual Meetings: Both Associations supported this item and recommended that the item be a Voting Item.

2012 NCWM Annual Meeting: Several stakeholders spoke in opposition on this item. Mr. Hayes remarked that the FALS worked on this item in 2007 and believes FALS needs to continue to work on this item. The NCWM L&R Committee agreed that this item is not ready and supports the continued development by FALS.

2012 CWMA Interim Meeting: General Motors (GM) supported this item for passenger vehicles, as these vehicles now have 4-micron filters. A state official commented that the CWMA had recommended modifying the language in this item to state that the 10-micron filter requirement would only apply to passenger type vehicles, and would specifically exempt high flow rate meters such as truck stop meters. CWMA supported this item provided that the earlier proposal be presented to limit the 10-micron filters to passenger vehicle meters and to specifically exempt high flow rate meters. CWMA recommended that this version of the item be a Voting Item.

2012 WWMA Annual Meeting: Mr. Gordon Johnson (Gilbarco) opposed the item because reducing a 30-micron filter to a 10-micron filter would drastically reduce flow rate to large capacity over-the-road trucks. The Committee did not believe that this issue falls within the scope of weights and measures and, therefore, would be unenforceable. No comments were received to support the item. WWMA recommended that this item be Withdrawn.

2012 SWMA Annual Meeting: An industry representative commented that the current technology to put a 10-micron filter on diesel at a truck stop will prohibit fuel from being dispensed in a timely manner and, therefore, opposes this. The Committee recommended that use of 10-micron filters be limited to passenger vehicle meters, and to specifically exempt high flow rate meters. SWMA recommended that the item be a Voting Item but with the changes as described by the Committee.

2012 NEWMA Interim Meeting: NEWMA reviewed comments from the CWMA meeting. NEWMA recommends review by the Fuels and Lubricants Subcommittee. NEWMA recommended that the item be an Informational Item.

2013 NCWM Interim Meeting: Mr. Hayes (FALS Chair) remarked that a similar item was brought before the Committee in 2007. FALS did not have enough time in their work session to work on this item. There are several stakeholders and states that are having issues with the terminology and would like it removed from the agenda. Mr. Hayes (Missouri) remarked that they supported this item because contamination is an issue with cars that do not have filtering systems. The Committee reviewed comments from the Regional Associations; however, FALS did not have sufficient time review and consider recommendation to the Committee. The Committee would like for FALS to continue to work on this item and is proposing this as an Informational Item.

2013 CWMA Annual Meeting: Several industry representatives did not support this item for they believe this was more of a dispenser protection issue than a consumer protection issue. A state regulator remarked it is a fuel quality issue to protect the consumer's vehicles and fuels systems such as high pressure fuel rails on newer diesel vehicles. This would not apply to high-flow diesel dispensers

2013 NEWMA Annual Meeting: The Committee proposes this item be Withdrawn.

2013 NCWM Annual Meeting: Mr. Hayes (FALS Chair) requested that the Committee allow the Subcommittee to continue to work on a recommendation for this item. There was opposition on moving this item forward. In less than two years since this proposal came forward, there has been no data developed. The Committee reviewed the association reports, Open Hearing comments, and letters received and changed the status of this item to Developing.

Additional letters, presentations, and data may have been part of the Committee's consideration. Please refer to Appendix F in the *Report of the 97th National Conference on Weights and Measures* (SP 1160, 2012) and Appendix G in this report (*Report of the 98th National Conference on Weights and Measures [2013]*) to review these documents.

270-5 D Handbook130, Section 4.3. Paper Plates and Sanitary Paper Products

Source:

Georgia Pacific (2013)

Purpose:

Add a more accurate and reproducible test method for verifying dimensions of disposable plates, bowls, and platters.

Item Under Consideration:

Amend NIST Handbook 133 as follows:

This appeared as Voting Item 260-4 in the *Committee Reports for the 98th Annual Meeting* (NCWM Publication 16, 2013).

4.3. Paper Plates and Sanitary Paper Products

The following procedure is used to verify the size of paper plates and other sanitary paper products. It may also be used to verify the size declarations of other disposable dinnerware.

Note: Do not distort the item's shape during measurement.

The count of sanitary paper products cannot be adequately determined by weighing. Variability in sheet weight and core weight requires that official tests be conducted by actual count. However, weighing can be a useful audit method. These products often declare total area as well as unit count and sheet size. If the actual sheet size measurements and the actual count comply with the average requirements, the total area declaration is assumed correct.

4.3.1. Test Equipment

- Steel tapes and rules. Determine measurements of length to the nearest division of the appropriate tape or rule.

- Metric Units:

For labeled dimensions 40 cm or less, linear measure: 30 cm in length, 1 mm divisions; or a 1 m rule with 0.1 mm divisions, overall length tolerance of 0.4 mm.

For labeled dimensions greater than 40 cm, 30 m tape with 1 mm divisions.

- Inch-pound Units:

For labeled dimensions 25 in or less, use a 36 in rule with $\frac{1}{64}$ in or $\frac{1}{100}$ in divisions and an overall length tolerance of $\frac{1}{64}$ in.

For dimensions greater than 25 in, use a 100 ft tape with in divisions and an overall length tolerance of 0.1 in.

- Measuring Base.

Note: A measuring base may be made of any flat, sturdy material approximately 38 cm (15 in) square. Two vertical side pieces approximately 3 cm (1 in) high and the same length as the sides of the measuring base are attached along two adjoining edges of the measuring base to form a 90° corner. Trim all white borders from two or more sheets of graph paper (10 divisions per centimeter or 20 divisions per inch). Place one sheet on the measuring base and position it so that one corner of graph paper is snug in the corner of the measuring base and vertical sides. Tape the sheet to the measuring base. Overlap other sheets on the first sheet so that the lines of top and bottom sheet coincide, expanding the graph area to a size bigger than plates to be measured; tape these sheets to the measuring base. Number each line from the top and left side of base plates: 1, 2, 3, etc.

- **Plate Dimension Tester**

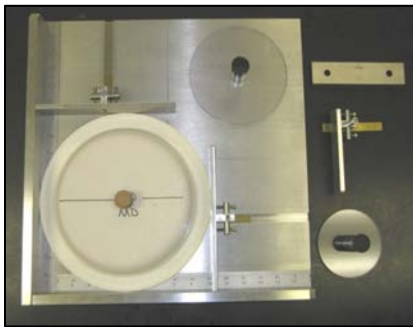

4.3.2. Test Procedure

- 1.* Follow Section 2.3.1. “Define the Inspection Lot.” Use a “Category A” sampling plan in the inspection; select a random sample.
2. Select an initial tare sample according to Section 2.3.5.1. “Determination of Tare Sample and Average Tare Weight.”
3. Open each package and select one item from each.

Note: Some packages of plates contain a combination of different-sized plates. In this instance, take a plate of each declared size from the package to represent all the plates of that size in the package. For example, if three sizes are declared, select three different plates from each package.

Note: Occasionally, packages of plates declared to be one size contain plates that can be seen by inspection to be of different sizes in the same package. In this instance, select the smallest plate and use the methods below to determine the package error. If the smallest plate is not short measure by more than the MAV, measure each size of plate in the package and calculate the average dimensions.

Example:

If five plates measure 21.41 cm (8.43 in) and 15 measure 21.74 cm (8.56 in), the average dimension for this package of 20 plates is 21.66 cm (8.53 in).

4. For paper plates **bowls or platters**: Place each item on the **plate dimension tester or** measuring base plate (or use the linear measure) with the eating surface down so two sides of the plate touch the sides of the **plate dimension tester or** measuring base. **If using the plate dimension tester, follow the test procedure for determining the plate, bowl or platter size.**

5. For other products: Use either the measuring base or a linear measure to determine actual labeled dimensions (e.g., packages of napkins, rolls of paper towels). If testing folded products, be sure that the folds are pressed flat so that the measurement is accurate.
6. If the measurements reveal that the dimensions of the individual items vary, select at least 10 items from each package. Measure and average these dimensions. Use the average dimensions to determine package error in Step 7 below.
7. The package error equals the actual dimensions minus the labeled dimensions.

4.3.3. Evaluation of Results

Follow the procedures in Section 2.3.7. “Evaluate for Compliance” to determine lot conformance.

Background/Discussion:

NIST Handbook 133, Section 4.3. Paper Plates and Sanitary Paper Products, identifies “Metric” and/or “Inch-Pound” steel tapes and rules or a “measuring base” as acceptable equipment for doing dimensional evaluations of paper plates and sanitary paper products. This proposal would add another acceptable piece of equipment that we call the ‘Plate Dimension Tester.’”

It is simpler, faster, and easier for an operator, technician, or regulator to use, and it is or more accurate and reproducible than the existing acceptable equipment listed in NIST Handbook 133, Section 4.3. Paper Plates and Sanitary Paper Products. For most products of this type (11.8 in or less) the current metric rule is identified as a 30 mm rule in 1 mm divisions (0.039 in), or a 1 m rule with 0.1 mm divisions (0.0039 in), and the inch-pound rule is a 36 inch rule with $\frac{1}{64}$ or $\frac{1}{100}$ divisions (0.015 in or 0.01 in). The acceptable divisions are somewhat different. The proposed tester uses a certified steel rule with divisions of 0.02 in that falls within the range of acceptable rules already listed in Section 4.3. Paper Plates and Sanitary Paper Products.

The measuring base described as acceptable uses graph paper with divisions of 0.05 in. That measuring base is described and constructed as follows:

A measuring base may be made of any flat, sturdy material approximately 38 cm (15 in) square. Two vertical side pieces approximately 3 cm (1 in) high and the same length as the sides of the measuring base are attached along two adjoining edges of the measuring base to form a 90 degree corner. Trim all white borders from two or more sheets of graph paper (10 divisions per centimeter or 20 divisions per in). Place one sheet on the measuring base and position it so that one corner of graph paper is snug in the corner of the measuring base and vertical sides. Tape the sheet to the measuring base. Overlap other sheets on the first sheet so that the lines of top and bottom sheet coincide, expanding the graph area to a size bigger than plates to be measured; tape these sheets to the measuring base. Number each line from the top and left side of base plates: 1, 2, 3, etc.

The submitter believes the accuracy of cutting the borders off the edges of graph paper, aligning the graph paper lines to match, and then taping them in place leaves a lot to be desired for accuracy when gathering data; especially when the expectations require the values to be read to such small increments. The plates need to touch the two sides of the measuring base, which require holding the plate flat against the measuring base and changes in that pressure can alter the values. The process of using rules can also cause problems when the plate edge must be perfectly aligned with the edges of the rule and then to make sure you have measured both directions in a perfect 90 degree angle. We, therefore, developed the Plate Dimension Tester to solve all those problems. He submitted separately pictures of the tester, a test procedure for using the tester, a video showing the use of the tester, some reproducibility data, and a letter from the Foodservice Packaging Industry (FPI), which represents 85 % of the companies producing these types of products, indicating their industry Technical Committee supports this proposal. The submitter believes his method would be a positive addition to NIST Handbook 133 without changing any of regulatory requirements; simply improving on the technical accuracy and reproducibility of the resulting data generated.

The Standard Test Method is contained in Appendix F (*Report of the 98th National Conference on Weights and Measures* [2013]) as well as additional pictures, reproducibility data, and a blueprint of a Plate Dimension Tester.

2012 SWMA Annual Meeting: Mr. Richard Davis (Georgia Pacific) expressed concern that importers are not compliant and are causing unfair competition to U.S. manufacturers (e.g., a 1/8 inch shortage in a paper plate can equate to over \$100,000 unfair advantage). Mr. Davis has submitted this proposal that would add an additional test method but would not change the current test procedures (steel rule or graph paper) in NIST Handbook 133. Mr. Davis believes that this is a more accurate procedure than what is currently adopted and would provide support if challenged in court. The device has an estimated cost of \$3000 and would be available through a third party. A video was shown describing how to operate and test. An industry official expressed concern on whether the equipment and disc can be certified and calibrated by a state lab. The Committee believes that the device would provide an additional option and improved test procedures for regulators and industry. SWMA forwarded the item to NCWM, recommending it as a Voting Item.

2013 NEWMA Annual Meeting: The Association heard from the Ms. Hockert that the NIST Dimensional Laboratory reported no problems with the testing device. Based on this new information, NEWMA believes this item is fully developed and recommends this as a Voting Item.

2013 CWMA Annual Meeting: The Association agreed that this is an improved test method and recommends it as a Voting Item.

2013 NCWM Interim Meeting: Mr. Davis provided a presentation that showed an overview on the test standard and equipment they are proposing to use in the test procedure. Mr. Davis believes that the item presented before the Committee will allow for greater efficiency, accuracy, repeatability, and uncertainty. This device will also allow for the testing of other products such as paper towels, napkins, and sandwich bags. Ms. Carol Hockert (NIST, OWM) volunteered to take the information to the NIST Dimensional Laboratory for further accuracy testing. The Committee feels that this item is developed and is recommending this item as a Voting Item.

2013 NCWM Annual Meeting: The Committee believes that additional work is needed on this item. The procedure title may need to reflect *bowls and platters*. A separate NIST Handbook 133 procedure also needs to be created in order to utilize the Plate Dimension Tester. Some spoke that it is not feasible to place the Plate Dimension Tester in the current test procedure in NIST Handbook 133 (2013). The Item Under Consideration also has a TAPPI standard reference, and there was not a copy of this standards available for review. There was testimony heard on this item, and it was concluded that it needs further development. The Committee returned this item to Developing status to give the submitter an opportunity to further develop this item.

Additional letters, presentations, and data may have been part of the Committee's consideration. Please refer to Appendix C, *Report of the 97th National Conference on Weights and Measures* (SP 1160, 2012) and Appendix F of this report (*Report of the 98th National Conference on Weights and Measures* [2013]) to review these documents.

270-6 D Section 3.10. Animal Bedding

This appeared as Voting Item 260-2 in the *Committee Reports for the 98th Annual Meeting* (NCWM Publication 16, 2013). At the 2013 NCWM Annual Meeting the Committee Modified the status of this item to a Developing Item. This is now identified as Item 270-6.

Source:

Central Weights and Measures Association (2012)

Purpose:

This proposal is to clarify appropriate test procedures for animal bedding.

Item Under Consideration:

Amend NIST Handbook 133, Test Procedures – For Packages Labeled by Volume as follows:

3.10. Mulch, and Soils, and Animal Bedding Labeled by Volume

Mulch is defined as “any product or material except peat or peat moss that is advertised, offered for sale, or sold for primary use as a horticultural, above-ground dressing, for decoration, moisture control, weed control, erosion control, temperature control, or other similar purposes.”

Soil is defined as “any product or material, except peat or peat moss that is advertised or offered for sale, or sold for primary use as a horticultural growing media, soil amendment, and/or soil replacement.”

Animal bedding is defined as “any product or material, except for baled straw or peat moss, that is advertised, offered for sale, or sold for primary use as a medium for animals to bed, nest or eliminate waste, such as compressed wood pulp or cellulose fibers (confetti, granules, or pellets), softwood shavings, shredded paper, compressed coconut fiber, ground corn cob, pelleted paper or wheat straw, cotton fibers, and bamboo products or any other material.”

Animal bedding as “animal bedding of all kinds, except for baled straw”

3.10.1. Test Equipment:

- A test measure appropriate for the package size that meets the specifications for test measures in Table 3-4. “Specifications for Test Measures for Mulch, ~~and~~ Soils and **Animal Bedding**”
- Drop cloth/polyethylene sheeting for catching overflow of material
- Level (at least 15 cm [6 in] in length)

**Table 3-4.
Specifications for Test Measures for Mulch, and Soils, and Animal Bedding**

Nominal Capacity of Test Measure ⁴	Actual Volume of the Measure ⁴	Interior Wall Dimensions ¹			Marked Intervals on Interior Wall ³	Volume Equivalent of Marked Intervals
		Length	Width	Height ²		
30.2 L (1.07 cu ft) for testing packages that contain less than 28.3 L (1 cu ft or 25.7 dry qt)	31.9 L (1.13 cu ft)	213.4 mm (8.4 in)	203.2 mm (8 in)	736.6 mm (29 in)	12.7 mm ($\frac{1}{2}$ in)	550.6 mL (33.6 in ³)
28.3 L (1 cu ft)	28.3 L (1 cu ft)	304.8 mm (12 in)	304.8 mm (12 in)	304.8 mm (12 in)		1179.8 mL (72 in ³)
56.6 L (2 cu ft)	63.7 L (2.25 cu ft)	304.8 mm (12 in)	304.8 mm (12 in)	685.8 mm (27 in)		
		406.4 mm (16 in)	228.6 mm (9 in)	685.8 mm (27 in)		
84.9 L (3 cu ft)	92 L (3.25 cu ft)	304.8 mm (12 in)	304.8 mm (12 in)	990.6 mm (39 in)		
		406.4 mm (16 in)	228.6 mm (9 in)	990.6 mm (39 in)		

Measures are typically constructed of 1.27 cm ($\frac{1}{2}$ in) marine plywood. A transparent sidewall is useful for determining the level of fill, but must be reinforced if it is not thick enough to resist distortion. If the measure has a clear front, place the level gage at the back (inside) of the measure so that the markings are read over the top of the mulch.

Notes

¹ Other interior dimensions are acceptable if the test measure approximates the configuration of the package under test and does not exceed a base configuration of the package cross-section.

²The height of the test measure may be reduced, but this will limit the volume of the package that can be tested.

³When lines are marked in boxes, they should extend to all four sides of the measure if possible to improve readability. It is recommended that a line indicating the MAV level also be marked to reduce the possibility of reading errors when the level of the mulch is at or near the MAV.

⁴The Nominal Capacity is given to identify the size of packages that can be tested in a single measurement using the dry measure with the listed dimensions. It is based on the most common package sizes of mulch in the marketplace. If the measures are built to the dimensions shown above the actual volume will be larger than the nominal volume so that plus errors (overfill) can be measured accurately.

(Amended 2010)

3.10.2. Test Procedure

1. Follow the Section 2.3.1. “Define the Inspection Lot.” Use a “Category A” sampling plan in the inspection, and select a random sample.
2. Open each package in turn. Empty the contents of the package into a test measure and level the contents by hand. Do not rock, shake, drop, rotate, or tamp the test measure. Read the horizontal marks to determine package net volume.

Note: Mulch: Some types of mulch are susceptible to clumping and compacting. Take steps to ensure that the material is loose and free flowing when placed into the test measure. Gently roll the bag before opening to reduce the clumping and compaction of material.

Compressed state animal bedding: To measure the usable volume, first empty the contents of the package on a drop cloth. Using your hands, or a tool if necessary, loosen the material until it is free of all clumps and compaction. When the product is free flowing, place in a test measure. To determine volume of the compressed state animal bedding, follow Section 3.9.1. “Compressed Volume Packages.”

3. Exercise care in leveling the surface of the mulch/soil/animal bedding and determine the volume reading from a position that minimizes errors caused by parallax.
4. Determine package errors by subtracting the labeled volume from the package net volume in the measure. Record each package error.

$$\text{Package Error} = \text{Package Net Volume} - \text{Labeled Volume}$$

3.10.3. Evaluation of Results

Follow the procedures in Section 2.3.7. “Evaluate for Compliance” to determine lot conformance.

Note: In accordance with Appendix A, Table 2-10. Exceptions to the Maximum Allowable Variations for Textiles, Polyethylene Sheeting and Film, Mulch and Soil Labeled by Volume, Packaged Firewood, and Packages Labeled by Count with 50 Items or Fewer, and Specific Agricultural Seeds Labeled by Count, apply an MAV of 5 % of the declared quantity to mulch, **and** soil **and animal bedding** sold by volume. When testing mulch and soil with a net quantity in terms of volume, one package out of every 12 in the sample may exceed the 5 % MAV (e.g., one in a sample of 12 packages; two in a sample of 24 packages; four in a sample of 48 packages). However, the sample must meet the average requirement of the “Category A” Sampling Plan.

Table 2-10. Exceptions to the Maximum Allowable Variations for Textiles, Polyethylene Sheeting and Film, Mulch, and Soils, and Animal Bedding Labeled by Volume, Packaged Firewood, and Packages Labeled by Count with 50 Items or Fewer, and Specific Agricultural Seeds Labeled by Count.	
	Maximum Allowable Variations (MAVs)
<u>Mulch, And Soil, and Animal Bedding Labeled By Volume</u>	<p>The MAVs are:</p> <p>For individual packages: 5 % of the labeled volume.</p> <p>For example: One package may exceed the MAV for every 12 packages in the sample (e.g., when the sample size is 12 or fewer, 1 package may exceed the MAV and when the sample size is 48 packages, 4 packages may exceed the MAV).</p> <p><u>NOTE: For Animal Bedding there is a temporary exemption not to apply the MAV. After July 2017, there will be an MAV of 5 % of the labeled volume applied to “animal bedding”</u></p>

(Amended 2010 **and 20XX**)

Background/Discussion:

NIST Handbook 130, Uniform Regulation for the Method of Sale, Section 2.23. Animal Bedding states:

2.23. Animal Bedding. – Packaged animal bedding of all kinds, except for baled straw, shall be sold by volume, that is, by the cubic meter, liter, or milliliter and by the cubic yard, cubic foot, or cubic inch. If the commodity is packaged in a compressed state, the quantity declaration shall include both the quantity in the compressed state and the usable quantity that can be recovered.

Example: 250 mL expands to 500 mL (500 in³ expands to 1000 in³).

(Added 1990) (Amended 2012)

However, NIST Handbook 133 does not include specific procedures for testing animal bedding volume declarations, compressed state quantity declarations, or usable quantity declarations. This proposal is to clarify appropriate test procedures for animal bedding.

2011 CWMA Interim Meeting: CWMA received this proposal and forwarded the item to NCWM recommending it as a Voting Item.

2012 NCWM Interim Meeting: The Committee made minor editorial changes to align the proposal with the format and language currently in NIST Handbook 133. The submitter had the word “uncompressed” added under the note section within “Evaluation of Results.” The Committee agreed and recommended to remove this word.

This proposal includes adopting both the mulch and soil test method and the evaluation of results for animal bedding. The method of evaluating results for mulch and soil testing includes an exception to the maximum allowable variation (MAV), the MAV is 5 %, and one package out of a 12 item sample (2 packages in a 24 item sample, 4 packages in a 48 item sample) is allowed to exceed the MAV. However, the sample must meet the average requirement of “Category A.” This MAV exception for mulch and soil was developed based on a study of mulch and soil test results. The Committee will ask industry to submit animal bedding product information and test data to determine if the MAV exception is appropriate for animal bedding.

An animal bedding industry representative was supportive of the 5 % allowance and also recommended a 12 × 12 × 12 cu ft vessel. The submitter of the proposal has been using the mulch test procedure to test animal

bedding and has not had issues using the procedure under the item for consideration. The 2012 L&R Committee designated this item as an Informational Item.

2012 NEWMA Annual Meeting: There were no comments. NEWMA recommended that the item remain as an Informational Item.

2012 CWMA Annual Meeting: Ms. Judy Cardin (Wisconsin) reported that there is no standard for animal bedding. Subsequently industry is using a variety of test methods that produce varying results. Wisconsin tested and found a wide variance in net quantity accuracy and found significant shortages in several instances. She encouraged other jurisdictions to test animal bedding and to share data with NIST, OWM. Missouri did a lot of testing at one facility and found a maximum of 36 % shortage and an average of 23 % shortage. Missouri's analysis further showed that the chipper had a great impact of the "spring effect" of compression. An industry representative recommended developing a method of sale for this commodity when sold from bulk since a significant amount of horse bedding is purchased in bulk. CWMA recommended that the item remain as an Informational Item.

2012 NCWM Annual Meeting: The L&R Committee requested that regulators and industry conduct animal bedding package testing, and submit their test results to Ms. Cardin at judy.cardin@wi.gov or to Mr. David Sefcik (NIST, OWM) at dsefcik@nist.gov. Preliminary analysis by NIST of available test data indicates that an exception for MAV is necessary for this product, but the Committee needs additional test data to determine the appropriate amount for that exception.

2012 CWMA Interim Meeting: There is no package testing standard in NIST Handbook 133 for animal bedding, and industry is currently using a variety of test methods that are resulting in significant non-compliance on package weights. Ms. Cardin announced that she is coordinating an animal bedding package testing survey to provide data to determine the appropriate exception to MAV for animal bedding. She asked CWMA states to participate in the October to November 2012 testing. A few states agreed to participate. CWMA recognized many states may not be able to participate given limited resources. The CWMA supported this item and recommended that the item be a Voting Item based on an appropriate MAV as determined by the study or, if the data is insufficient, using the established MAV for mulch, a similar product.

2012 WWMA Annual Meeting: Mr. Kurt Floren (Los Angeles County, California) remarked that this item is noteworthy but questioned whether it recognizes all types of animal bedding in the marketplace (e.g., ground corn cobs and shredded paper). Ms. Macey commented in support, but she would like to see additional data collected. The NIST Technical Advisor requested that states submit data on animal bedding inspections to NIST. The Committee agreed that more studies and data are needed and recommended that the results be submitted to the NCWM. The Committee believed that a better definition is needed to address various animal bedding products. WWMA recommended that the item be an Informational Item.

2012 SWMA Annual Meeting: A NIST Technical Advisor commented that the chair of the NCWM L&R is requesting states to participate in the package testing of animal bedding over the next two months in order to provide more data to help determine the appropriate MAV. SWMA recommended that the item be an Informational Item unless there is strong evidence from the survey for an appropriate MAV; in which case, SWMA would recommend it as a Voting Item.

2012 NEWMA Annual Meeting: NEWMA would like to see results of the CWMA study before action is taken on the proposal. NEWMA recommended that the item be an Informational Item.

2013 NCWM Interim Meeting: Mr. David Sefcik provided a summary of the data that was received from states and manufacturers that tested animal bedding. The findings were limited participation and very few lots passed; therefore, NIST could not make a recommendation for a MAV. Data shows there is a bigger concern than determining correct MAV. Even with applying a 5 % MAV, almost all the lots would have failed. There were also significant variations in labeled content, variability on bedding materials, different types of packing machines, and volumetric test measures. It was agreed the test procedure for mulch could be used for animal bedding. The recommendation made was the Committee should consider a temporary exemption from the MAV (three to five years). This would provide an exemption from the current MAV which is too restrictive while giving the

Committee and NIST additional time for data to be collected to determine the proper MAV. NIST will work with stakeholders to develop a standardized test measure.

Mr. Jim Byers (San Diego County, California) expressed concern that animal bedding needs to be clearly defined. Mr. Byers submitted recommended language to define animal bedding as follows:

Section 3.10. Mulch, and Soils, and Animal Bedding Labeled by Volume

“Any product or material, except for baled straw, that is advertised, offered for sale, or sold for primary use as a medium for animals to bed, nest or eliminate waste, such as compressed wood pulp or cellulose fibers (confetti, granules, or pellets), softwood shavings, shredded paper, compressed coconut fiber, ground corn cob, pelleted paper or wheat straw, cotton fibers, and bamboo products or any other material.”

Mr. Floren agrees with Mr. Byers and Mr. Sefcik on their recommendations. Mr. Rich Whiting (American Wood Fibers) spoke that they participated and their lots did not pass. American Wood Fibers would like to see a test measure and quantity control practices developed by NCWM.

The Committee agrees with the definition for animal bedding drafted by Mr. Byers with the addition of peat moss as an exemption. It was agreed to remove the MAV requirement for animal bedding, and the Committee is recommending that the states test animal bedding on the “average requirement.” The removal of the MAV for animal bedding would be a temporary exemption for a four-year period; after which time, the MAV would default to the 5%. There was no objection from NIST on the test procedure. Information will need to be obtained from industry to determine an accurate test measure. It was also agreed to put a sunset date of July 2017 into the language. With these changes, the Committee proposes this as a Voting item.

2013 NEWMA Annual Meeting: The NIST Technical Advisor remarked that they continue to collect data on this subject matter. The Committee believes that there is sufficient data to support this item and recommends it as a Voting Item.

2013 CWMA Annual Meeting: The NIST Technical Advisor remarked that the date in the MAV table was open ended and consideration should be given to make it date specific. NIST continues to analyze testing data. States should continue to send test data to NIST. The Committee recommends that a date for the temporary exemption read July 1, 2017, and moves this forward as a Voting Item.

2013 NCWM Annual Meeting: A regulator opposed the item as written due to animal bedding being defined within a test procedure for mulch and soil. He questions how the 5% MAV was calculated. He also does not recommend a fix of applying a temporary MAV exemption. The Committee concurs that this item is not ready to move forward as a Voting Item and moved this item to Developing so the submitter can further develop. The definition needs to be reviewed to determine any exemptions that may apply for items currently sold by weight. Reconsideration should also be given to whether a three-year exemption to the MAV is appropriate. The Committee believes this item needs to be further developed and returned to the submitter.

Ms. Judy Cardin, Wisconsin, Committee Chair
Mr. Raymond Johnson, New Mexico (Acting Chair at the 2013 NCWM Annual)
Mr. Tim Lloyd, Montana
Mr. Richard Lewis, Georgia
Mr. Louis Sakin, Towns of Hopkinton/Northbridge, Massachusetts

Mr. Rob Underwood, Petroleum Marketers Association of America | Associate Membership Representative
Mr. Lance Robertson, Measurement Canada | Canadian Technical Advisor
Mr. David Sefcik, NIST, OWM | NIST Technical Advisor
Ms. Lisa Warfield, NIST, OWM | NIST Technical Advisor

Laws and Regulations Committee

THIS PAGE INTENTIONALLY LEFT BLANK

Appendix A

NIST Handbook 130 – Uniform Packing and Labeling Regulation

Item:

231-2: 10.3. Aerosols and Similar Pressurized Containers

Table of Contents

Item	L&R – A Page
BP Beaumont Products, Inc. (April 5, 2013).....	3
BP Beaumont Products, Inc./Mr. Douglas Fratz, CSPA (March 4, 2013)	5
CSPA/NAA Proposed Revisions to NIST Handbook 130 – 2012	7
Mr. Douglas Frantz/Mr. Hank Picken (e-mail, March 7, 2013)	8
BP Beaumont Products, Inc., Presentation at the NCWM Annual Meeting, July 15, 2103	9

THIS PAGE INTENTIONALLY LEFT BLANK



Beaumont Products, Inc.

April 5, 2013

Ms. Judy Cardin
Wisconsin Weights and Measures
2811 Agriculture Drive
P.O. Box 8911
Madison, WI 53708-8911

Dear Ms. Cardin

It is clear from Mr. Fratz March 7, 2013 response (attached) to my letter of March 4, (attached) that he and The Aerosol Products Division of the CSPA have no intention of helping the BOV "group" communicate important differences between aerosols and BOV containers to consumers. Mr. Fratz continues to want to ignore the fact that there are important differences between Aerosols and the BOV system.

The laws, regulations and definitions of aerosols, which he refers to, for the most part were promulgated long before the BOV system was invented and are, therefore, badly in need of revision. These old regulations are being used by the Aerosol Products Division of the CSPA to protect the aerosol industry and are stifling the BOV group's ability to clearly communicate the consumer benefits of the new, environmentally-friendly, non-aerosol BOV system.

And, for the edification of all interested parties, I met with, along with other BOV representatives, members of Mr. Fratz's Association (including Mr. Raymond) in Dallas, Texas on May First of last year, in a good-faith effort to seek common ground on this issue. In fact, we thought we had found a workable compromise as outlined in Mr. Raymond's November draft proposal. Unfortunately, the agreed-to-proposal was not the one Mr. Raymond presented during the January NCWM meeting in Charleston.

I respectfully suggest that perhaps this issue may go beyond the purview of the NCWM and perhaps should be referred to the FTC and treated as a Truth in Advertising/labeling issue?

Is it possible to get sometime on your calendar in the next couple of months to meet to fully discuss this issue?

1560 Big Shanty Drive • Kennesaw, GA 30144 • (770) 514-9000 • Fax (770) 514-7400 • 1-800-451-7096

L&R Committee 2013 Final Report
Appendix A – Item 231-2: Packaging and Labeling Regulation

By cc. Mr. Fratz, if I have misunderstood the intent of your most recent email on this subject, please let me know.

Sincerely yours,



Hank Picken
President & CEO
Beaumont Products, Inc.

Attachments (2)

March 4, 2013 letter to Doug Fratz
March 7, 2013 response from Doug Fratz

cc:

David Sefcik - NIST
Don Onwiler - NCWM
Paul Hertensen – BOV Solutions
Richard Miller – Technical Chemical
Jok S. Ang – Citrus Mate
Doug Fratz – Aerosol Products Division - CSPA
Doug Raymond – Regulatory Resources



Beaumont Products, Inc.

March 4, 2013

Mr. D. Douglas Fratz
CSPA
1667 K Street Suite 300
Washington DC 20006

Dear Doug:

I'm writing in response to your email of January 31, 2013 in which you invited us to join your Association.

At this point, we are not interested in joining your Association unless and/or until you recognize that there are differences between Aerosols and BOV pressurized containers and demonstrate a willingness to help us communicate these differences to Consumers. We firmly believe that at the heart of the BOV labeling issue is the requirement to educate and protect consumers ... not to protect the Aerosol Industry.

There are as many definitions in support of our contention that BOV's are not Aerosols as there are definitions that support your position that BOV's are Aerosols. The fact is that there are differences and consumers recognize these differences! Consumer Market Research on this subject substantiates consumer perceptions of these differences; and that the BOV system provides a solution to the many consumer concerns surrounding Aerosols. "Truth in Advertising" mandates that we act in the best interests of Consumers by clearly communicating differences between BOV's and Aerosols. We trust we can do this without involving the Federal Trade Commission.

For the record, the proposed revisions to the NIST Handbook, as presented by Mr. Doug Raymond, at the Charleston NCWM meeting on January 28, 2013, was not the same drafted proposal that we, the BOV "group", reviewed and agreed to back in November. And, we consider this unilateral change to be totally unprofessional. For the edification of the interested parties, copied below, I have attached the two different Proposed Revisions – the November reviewed-and-agreed-to proposal and the January un-reviewed-revision. Up until the January NCWM meeting, the BOV Group believed that your Association was acting in accordance with NCWM's request for you to reach a consensus position, with the BOV Group, not a unilateral one.

Further, the argument that there is no acceptable test methodology to measure the net volume is spurious. Since the BOV system does not aerosolize the payload, dispensed by the container, it is quite simple to collect all of the liquid, dispensed by the BOV container into a beaker, simply by removing the actuator, inverting the can and depressing the dip tube. Once exhausted the liquid volume is easy to measure with a graduated scale. As you well know, the ECU has been doing this with BOV containers for years.

The very fact that a QC test, is so easily done with a BOV underscores the real difference between an Aerosol and a BOV container – the “small particles of a liquid or solid are NOT suspended in a gas” (i.e., not aerosolized), so it is easy to collect.

Please let me know if you are willing to work with us to come up with a True consensus position regarding labeling and QC testing which will provide Consumers with the information required to make an informed choice between Aerosols and the BOV’s.

Sincerely yours,

Hank Picken

Attachments (2)

November: “Agreed-to-Proposal”

January: “Unilateral Proposal”

cc:

David Sefcik - NIST

Don Onwiler - NCWM

Judy Cardin - NIST

Paul Hertensen – BOV Solutions

Richard Miller – Technical Chemical

Doug Raymond – Reg Resources

CSPA/NAA Proposed Revisions To NIST Handbook 130 - 2012

Provisions Related to Aerosols and Similar Pressurized Containers

6.3. Net Quantity. – A declaration of net quantity of the commodity in the package, exclusive of wrappers and any other material packed with such commodity (except as noted in Section 10.3. Aerosols and Similar Pressurized Containers), shall appear on the principal display panel of a consumer package and, unless otherwise specified in this regulation (see Sections 6.6. through 6.9. Prescribed Units), shall be in terms of the largest whole unit.

(...)

10.3 Aerosols and Similar Pressurized Containers - The declaration of quantity on a pressurized container shall disclose the net quantity of the commodity (including delivered propellant), in terms of weight, that will be expelled when the instructions for use as shown on the container are followed.

10.3.1 Pressurized Containers which utilize Bag-on-Valve (BOV) technology or similar technology that does not expel the propellant shall be permitted to disclose the net quantity in terms of either net weight or net volume. Those products in pressurized containers using net volume declaration must be registered with the National Conference of Weights and Measures as meeting the requirements to use this provision or be labeled "Meets NCWM section 10.3.1".

Hank Picken

From: Doug Fratz <DFratz@cspa.org>
Sent: Thursday, March 07, 2013 3:54 PM
To: Hank Picken
Cc: rmiller@technicalchemical.com; judy.cardin@wisconsin.gov; dononwiler@ncwm.net; paul@bovsolutions.com; dsefcik@nist.gov; Doug Raymond
Subject: March 4th Letter

Dear Hank:

I regret that you are declining my latest invitation to become a member of CSPA. Our Aerosol Products Division includes more than 140 companies involved in the wide and diverse aerosol industry, including many that market bag-on-valve products or the packaging components that go into them. Each type of aerosol product technology has distinct strengths, and CSPA works to support the interests of all of them.

CSPA created an ad hoc BOV Workgroup early last year as a courtesy to allow several non-CSPA-member companies such as yours to provide input to CSPA members on several issues, including this one. We invited all to join CSPA last year, and some did and some did not. The change in CSPA member consensus on the weights and measures issue this year occurred upon further reflection by CSPA members that market BOV and other aerosol products. We attained 100% consensus of our members to seek allowance for dual labeling of both net weight and net volume, and therefore made that proposal to the NCWM. (If you can provide a shelf-test protocol to measure net volume, that may be useful in the NCWM consideration of whether net volume can be allowed.) Very few CSPA members, however, would seek to move their BOV products to dual declaration, as most are satisfied with net weight declaration. And absolutely no current members are supporting the comprehensive campaign that would be needed to seek to change the dozens of federal and state laws, codes and regulations that classify BOV aerosol products with other aerosol products.

CSPA will continue to represent the broad range of companies in the aerosol products industry, and I continue to hope that one day Beaumont Products will join us to work together on the common issues we face.

D. Douglas Fratz

Vice President, Scientific & Technical
Affairs and
Aerosol Products Division Staff
Executive

1667 K Street Suite 300
Washington, DC 20006

dfrazt@cspa.org
P (202) 833-7304
F (202) 872-0720

www.cspa.org

CSPA's 2013 Mid-Year Meeting
"The Evolving Marketplace"
Chicago, IL | May 7-10 | Click to [Register Now](#)



Representing Household & Institutional Products

Aerosol • Air Care • Cleaners • Polishes
Automotive Care • Antimicrobial • Pest Management

National Conference on Weights & Measures

Louisville, Kentucky
July 15, 2013



Beaumont Products, Inc.

2013 Small Business of the Year

[1]

Introduction

Hank Picken
President & CEO Beaumont Products, Inc.

- ❖ Over 40 years of Consumer Products Industry Experience
 - Unilever
 - Pfizer
 - Colgate Palmolive
- ❖ Aerosol Experience - Marketing
 - Pfizer (Barbasol – Shave Cream)
 - Colgate Palmolive (Nordika – Personal Deodorant)
- ❖ Manufacturing & Marketing
 - AMREP – Specialty Chemicals

[2]

About Beaumont Products, Inc

- ❖ Manufacturer & Marketer of Natural Consumer Products since 1991
- ❖ Produce approximately 1 MM Bag-on-Valve (BOV) containers per year
- ❖ Pioneered non-aerosol delivery systems (natural positioning)
 - Excel/Atmos
 - Hans Stoffel
 - CCL
- ❖ Member of the “BOV Group”
- ❖ Not members of, nor are we represented by, the Aerosol Products Division of the CSPA (Consumer Specialty Products Association).
- ❖ We do not support the January 22, 2013 CSPA/NAA proposal on this subject requiring BOV's to declare both weight & volume



[3]

The “Issue”...

Should BOV's declare dispensable contents on a Net Volume (liquid) basis like all other non-aerosol liquids or should BOV's be required to label in accordance with Aerosol standards and declare contents in weight?

[4]

Objective

To clearly communicate the “dispensable” content of a BOV container to consumers, while emphasizing the differences between BOV's and Aerosols.

[5]

Support

- ❖ BOV's should use net volume (liquid) declaration because it is a clear communication of the useful and dispensable content.
- ❖ To use weight is to mislead the consumer into believing that the weight of the gas is part of the product and blurs the differences between BOV's and Aerosols.
- ❖ Since the gas in a BOV container never mixes with the product and the gas never leaves the can, it should be considered part of the package and not part of the dispensed product.

[6]

Bag on Valve

– A Unique Non-aerosol, Environmentally Safe Spray Container –

Embedded Content Unavailable

7

Bag on Valve

– A Unique, Non-aerosol, Environmentally Safe Spray Container

- ❖ Components
- ❖ Filling (Under Cap - gas & through dip tube - product)
- ❖ *Gas never mixes with the product*
- ❖ *Gas never leaves the can*
- ❖ Inert gas – either ambient air or nitrogen
- ❖ No “gas house” used in manufacturing



8

Proposal

❖ Agreed to CSPA/NAA/BOV Group (November 14, 2012) Proposed Revisions to NIST Handbook 130-2012:

CSPA/NAA Proposed Revisions To NIST Handbook 130 - 2012

Provisions Related to Aerosols and Similar Pressurized Containers

6.3. Net Quantity. – A declaration of net quantity of the commodity in the package, exclusive of wrappers and any other material packed with such commodity (except as noted in Section 10.3. Aerosols and Similar Pressurized Containers), shall appear on the principal display panel of a consumer package and, unless otherwise specified in this regulation (see Sections 6.6. through 6.9. Prescribed Units), shall be in terms of the largest whole unit.

(...)

10.3 Aerosols and Similar Pressurized Containers - The declaration of quantity on a pressurized container shall disclose the net quantity of the commodity (including delivered propellant), in terms of weight, that will be expelled when the instructions for use as shown on the container are followed.

9

Proposal (continued...)

10.3.1 Pressurized Containers which utilize Bag-on-Valve (BOV) technology or similar technology that does not expel the propellant shall be permitted to disclose the net quantity in terms of either net weight or net volume. Those products in pressurized containers using net volume declaration must be registered with the National Conference of Weights and Measures as meeting the requirements to use this provision or be labeled “Meets NCWM section 10.3.1.”

Label As:

Non-Aerosol, Pressurized BOV Spray Container

(Provided that only inert, non-flammable/non-combustible gas is used and that no gas is introduced into the bag)

10

Support for Proposal

- ❖ BOV’s are Non-Aerosol, Pressurized Containers
 - There is no mixing of gas and product.
 - Gas remains in the can as part of the package.
 - Relative ease to measure dispensed product.
- ❖ In contrast, in aerosols gas (propellant) is mixed with the product and is dispersed with the product

11

Industry Definitions of Aerosols

(Pre-date the BOV)

However, there are many definitions of Aerosols which would exclude BOV’s. For example, from the Hawley’s Condensed Chemical Dictionary:

“A suspension of liquid or solid particles in a gas, the particles often being in the colloidal size range. Fog and smoke are common examples of natural aerosols, fine spray (perfumes, insecticides, inhalants anti-perspirants, paints, etc.) are man-made.”

12

Industry Definitions of Aerosols

(continued...)

Consumer Definition from Market Research:

From a Consumer Market Research study conducted by The Atlantis Group, June 7, 2012, consumers defined Aerosols as follows:
"A pressurized can, containing a mixture of gas and product (payload) that is sprayed by pressing the button (actuator). The sprayed product is thus diluted with gas".

*EU requires liquid fill declaration for both Aerosols and BOV's



13

Proposed BOV Test Protocol

- The Measurement of Dispensed Liquid from a BOV -

Video content unavailable

File Name: BOV Protocol Applied to BOV Video 2

14

Issues with same Protocol applied to an Aerosol - Underscores the differences

Video content unavailable

File Name: BOV Protocol Applied to Aerosol Video 3

15

FTC Guidelines on Comparative Advertising

(From a "Statement of Policy Regarding Comparative Advertising" FTC August 13, 1979).

- ❖ "(Advertisers should not be restrained) from making truthful and non-deceptive statements that a product has certain desirable properties or qualities which a competing product or products do not possess. Such a comparison may have the effect of disparaging the competing product, but we know of no rule of law which prevents a seller from honestly informing the public of the advantages of its products as opposed to those of competing products"
- ❖ "Industry codes which restrain comparative advertising in this manner are subject to challenge by the Federal Trade Commission"

16

Conclusions

- ❖ There are real differences between Aerosols and BOV's, and there is an obligation to clearly communicate these differences to consumers.
- ❖ A dispensed-net volume (liquid – fl oz, or mL) content declaration and non-aerosol statement would help communicate these differences.
- ❖ To use net weight is to mislead the consumer into believing that the weight of the gas is part of the product and blurs the differences between BOV's and Aerosols.

17

Slides 18 and 19 contain no technical content or graphics; therefore, they are omitted from this document.

Aerosol Weight Test

Video content unavailable

20

File Name:
Aerosol Weight Test Video 4



ATLANTIS
Solutions To Unfathomable Problems

REPORT ON AEROSOLS

The following represents consumer playback from a discussion on aerosols, which was part of a focus group project conducted by The Atlantis Group in Atlanta, GA on June 7, 2012.

Definition of an Aerosol:
A pressurized can, containing a mixture of gas and product (payload) that is sprayed by pressing the button (actuator). The sprayed product is thus diluted with gas.

Negative Comments About Aerosols:

- Harmful to the environment
- Contains CFC's
- Bad for the ozone layer
- Highly flammable
- Harmful to breath
- Hazardous to inhale
- Causes respiratory problems
- Puts toxic fumes into the environment
- Causes allergic reaction ... asthma attacks
- Contains a bunch of chemicals
- Noisy, high-powered spray
- Less "product" in the can
- Expensive – aerosols charge for product & propellant
- "Potentially causes cancer"
- Not appropriate for food related uses due to small particles in the propellant

Positive Comments about Aerosols:

- Convenient
- Light weight
- Easy to use
- Targeted Spray
- Even Distribution
- Less messy than other packages
- Quick application
- Good even coverage

21

CSPA/NAA Proposed Revision

CSPA/NAA Proposed Revisions To NIST Handbook 130 - 2012

Provisions Related to Aerosols and Similar Pressurized Containers

6.3. Net Quantity. – A declaration of net quantity of the commodity in the package, exclusive of wrappers and any other material packed with such commodity (except as noted in Section 10.3. Aerosols and Similar Pressurized Containers), shall appear on the principal display panel of a consumer package and, unless otherwise specified in this regulation (see Sections 6.6. through 6.9. Prescribed Units), shall be in terms of the largest whole unit.

(...)

10.3 Aerosols and Similar Pressurized Containers - The declaration of quantity on a pressurized container shall disclose the net quantity of the commodity (including delivered propellant), in terms of weight, that will be expelled when the instructions for use as shown on the container are followed.

10.3.1 Pressurized Containers which utilize Bag-on-Valve (BOV) technology or similar technology that does not expel the propellant shall be permitted to disclose the net quantity in terms of both net weight and net volume. This option allows consumer value comparison with various other product delivery forms that may be either net weight or net volume.

THIS PAGE INTENTIONALLY LEFT BLANK

Appendix B

Handbook 130 – Uniform Regulation for Method of Sale of Commodities and Uniform Engine Fuels and Automotive Lubricants Regulation

Items:

232-1: Uniform Method of Sale:

2.27. Retail Sales of Natural Gas Sold as a Vehicle Fuel

237-1: Uniform Engine Fuels and Automotive Lubricants Regulation:

Section 1. Definitions – Diesel Liter Equivalent (DLE) and Diesel Gallon Equivalent (DGE)

Table of Contents

Items	L&R Appendix B – Page
Clean Vehicle Education Foundation, Douglas Horne.....	3

THIS PAGE INTENTIONALLY LEFT BLANK

Clean Vehicle Education Foundation



Proposal for CNG & LNG - DGE

NCWM Interim Meeting
January 28, 2013

Douglas Horne – President

www.cleanvehicle.org

1

Why DGE is Now Needed by the NGV Market

- In the 1994 NCWM set GGE at 5.66 lbs but deferred the development of DGE because:
 - The consumer market was LD gasoline conversions 
 - and diesel class NGVs were fleets such as transit that use private stations. 
 -  and diesel class NGVs were fleets such as transit that use private stations. 

In the last twenty years the market growth has been in HD vehicles and now a national network of public CNG and LNG fueling is emerging



America's natural gas highway



CNG Class 8 

LNG Class 8 

CNG HD 

www.cleanvehicle.org

2

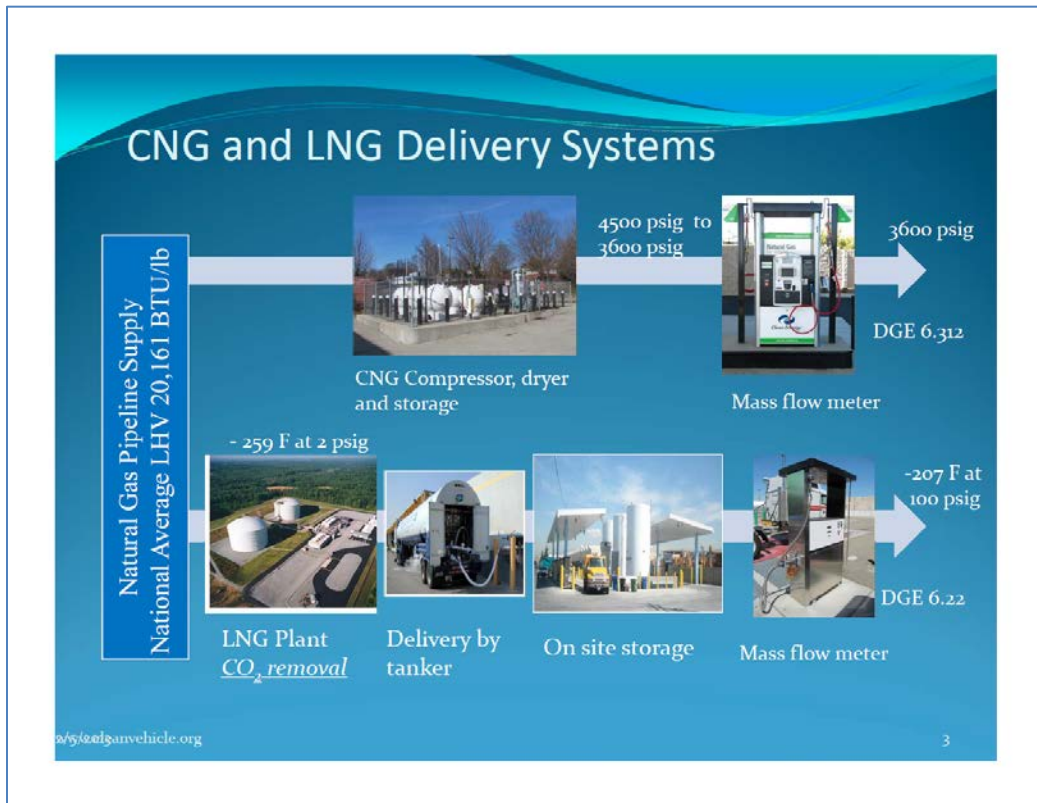

DGE Based on CNG Composition Used in 1994 GGE Calculation

- The 1994 acceptance NCWM of Gasoline Gallon Equivalent (GGE) for natural gas to be equal to 5.660 lbs was based on a national weighted average composition of natural gas
 - energy content (lower heating value – LHV) of 923.7 BTU/scf
 - density of 0.0458172 lbs/scf
 - or 20,160,551 BTU/lb
- Using the the same natural gas composition and the ratio of the LHV of diesel to the LHV of gasoline as noted in Table B.4 of the DOE Transportation Energy Data Book
 - $128,700/115,400 \times 5.660$ gives the Diesel Gallon Equivalent (DGE) of 6.312 lbs
- For those NGVs that use CNG as a replacement for diesel then the average energy equivalent per gallon would be 6.312 lbs

www.nrg.com

4

DGE Based on LNG Composition

National Average Natural Gas Composition Used for GGE Standard - Applied to LNG DGE Calculation							
Components	CNG			LNG			
	LHV - BTU/LB	LBS/CF	%V ¹	%V ²	LBS/CF	%MASS	LHV
C1	21537	0.0425	92.87	93.59	0.039777614	87.9239176	18936.17413
C2	20394	0.0803	3.34	3.37	0.00270294	5.974542668	1218.448232
C3	19807	0.1196	0.63	0.63	0.000759357	1.678473095	332.4551659
i-C4	19529	0.1582	0.07	0.07	0.000111604	0.246887517	48.17560525
n-C4	19815	0.1582	0.12	0.12	0.000191321	0.422892887	83.79622551
i-C5	19478	0.1907	0.04	0.04	7.8875E-05	0.169923459	33.09769129
n-C5	20485	0.1907	0.03	0.03	5.76562E-05	0.127442594	26.10661539
C8	19403	0.0228	0.05	0.05	1.14889E-05	0.025394958	4.927383785
N2	0	0.0744	2.07	2.09	0.001552093	3.430725227	0
CO2	0	0.117	0.78		0	0	0
			100	100	0.045240948	100	20683

Diesel³ LHV= 128,700

LNG - DGE= 6.22

¹ CNG national average composition of natural gas from the NCWM Laws and Regulations - CNG Working Group letter 10/18/1993 Appendix A. Conversion Factor Background

² LNG composition based on CNG composition with CO2 removed

³ DOE Transportation Energy Data Book Table B.4

www.algavehicle.org 5

Proposal

- CNG dispensers may dispense natural gas in two units:
 - GGE = 5.66 lbs
 - DGE = 6.312 lbs
- LNG dispensers will dispense LNG in one unit:
 - DGE = 6.22 Lbs

www.algavehicle.org 6

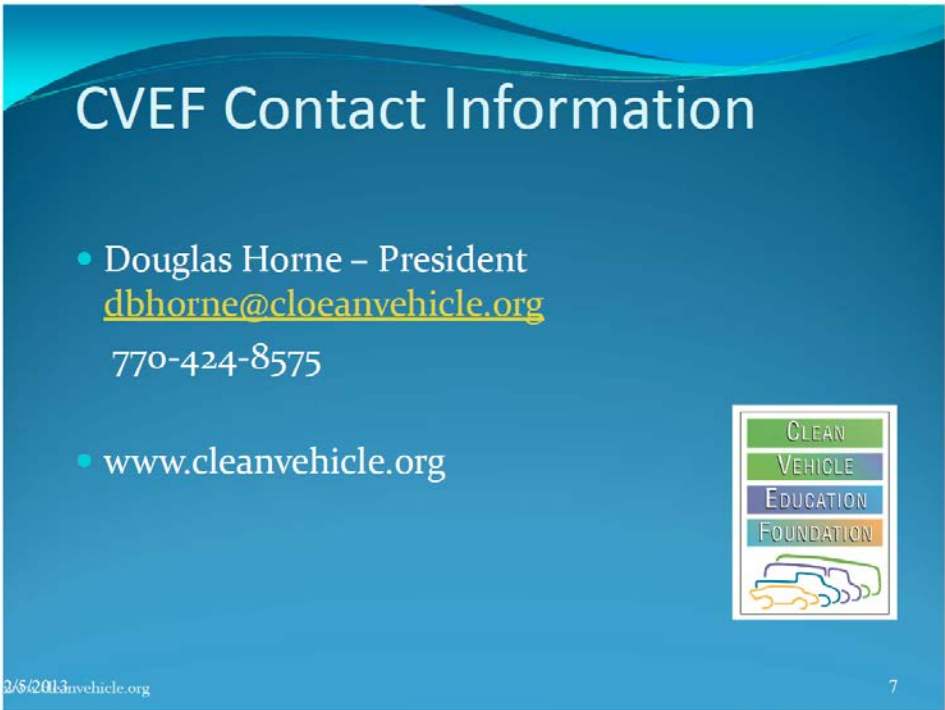

CVEF Contact Information

- Douglas Horne – President
dbhorne@cleanvehicle.org
770-424-8575
- www.cleanvehicle.org



2/5/2013 cleanvehicle.org 7

The slide features a blue background with a white wavy border at the top. The title 'CVEF Contact Information' is in white. The contact information is listed in white text with a blue bullet point. The logo is a vertical stack of four colored boxes (green, blue, purple, orange) with the text 'CLEAN VEHICLE EDUCATION FOUNDATION' and a stylized car icon below. The footer contains the date and website URL on the left and the number '7' on the right.

Appendix C

Handbook 130 – Uniform Regulation for Method of Sale of Commodities and Uniform Engine Fuels and Automotive Lubricants Regulation

Items:

Item 232-2: Uniform Method of Sale of Commodities:
2.33. Oil,
2.33.1.4. Engine Service Category,
2.33.1.4.1. Vehicle or Engine Manufacturer Standards, and
2.33.1.4.2. Inactive or Obsolete Service Category

Item 237-4: Uniform Engine Fuels and Automotive Lubricants Regulation:
3.13. Oil,
3.13.1.4. Engine Service Category,
3.33.1.4.1. Vehicle or Engine Manufacturer Standard, and
3.13.1.4.2. Inactive or Obsolete Service Categories)

Table of Contents

Items	L&R Appendix – C Page
API Motor Oil Guide	3
API, Kevin Ferrick	5

THIS PAGE INTENTIONALLY LEFT BLANK

API Motor Oil Guide



API'S CERTIFICATION MARK AND SERVICE SYMBOL

Identify quality motor oils for gasoline- and diesel-powered vehicles. Oils displaying these marks meet performance requirements set by U.S. and international vehicle and engine manufacturers and the lubricant industry. More than 500 companies worldwide participate in this voluntary program, which is backed by a marketplace sampling and testing program.

GET MORE FROM YOUR MOTOR OIL.

Follow vehicle manufacturer's oil change recommendations. This includes using recommended SAE oil viscosity and ILSAC or API performance standard.

If you find it necessary to mix brands of oil, use the same viscosity grade and API service category to maintain performance.

Properly dispose of used oil. Learn more about recycling used oil at www.recycleoil.org. Go to www.earth911.com for used oil collection center locations.

ASK FOR API-LICENSED OIL WHENEVER YOU HAVE YOUR OIL CHANGED.

LOOK FOR THE API CERTIFICATION MARKS EVERY TIME YOU BUY MOTOR OIL.

FOR MORE INFORMATION VISIT WWW.API.ORG/EDLCS

LEARN ABOUT THE CHEMICAL ADDITIVES IN MOTOR OIL AT WWW.AMERICANCHEMISTRY.COM



THE API CERTIFICATION MARK, ALSO KNOWN AS THE "STARBURST"

An oil displaying this mark meets the current engine protection standard and fuel economy requirements of the International Lubricant Standardization and Approval Committee (ILSAC), a joint effort of U.S. and Japanese automobile manufacturers. Automobile manufacturers recommend oils that carry the API Certification Mark. See the ILSAC STANDARD FOR PASSENGER CAR ENGINE OILS chart on the next page for descriptions of current and obsolete ILSAC standards.

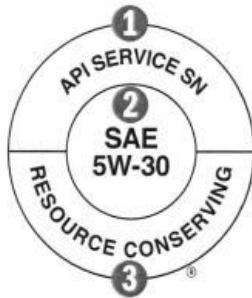

THE API SERVICE SYMBOL, ALSO KNOWN AS THE "DONUT"

1. PERFORMANCE LEVEL

Gasoline engine oil categories (for cars, vans, and light trucks with gasoline engines): Oils designed for gasoline engine service fall under API's "S" (Service) categories. See inside for descriptions of current and obsolete API service categories. Diesel motor oil categories (for heavy-duty trucks and vehicles with diesel engines): Oils designed for diesel-engine service fall under API's "C" (Commercial) categories. See the GASOLINE ENGINES and DIESEL ENGINES charts on the next pages for descriptions of current and obsolete API service categories.

2. VISCOSITY GRADE

The measure of an oil's ability to flow at certain temperatures. Vehicle requirements may vary. Follow your vehicle manufacturer's recommendations on SAE oil viscosity.

3. RESOURCE CONSERVING or ENERGY CONSERVING

These designations apply to oils intended for gasoline-engine cars, vans, and light trucks. Widespread use of "Resource Conserving" or "Energy Conserving" oils may result in an overall savings of fuel in the vehicle fleet as a whole.

4. MULTIPLE PERFORMANCE LEVELS

Oils designed for diesel engine service might also meet gasoline engine service. For these oils the designation is "C" category first followed by the "S" category. "C" category oils have been formulated primarily for diesel engines and may not provide all of the performance requirements consistent with vehicle manufacturers' recommendations for gasoline-fueled engines.

5. THE API SERVICE SYMBOL WITH CI-4 PLUS

The "CI-4 PLUS" designation identifies oils formulated to provide a higher level of protection against soot-related viscosity increase and viscosity loss due to shear in diesel engines. When originally introduced, CI-4 PLUS identified CI-4 oils meeting a higher level of performance. CJ-4 oils include all CI-4 PLUS performance requirements. CI-4 PLUS appears in the lower portion of the API Service Symbol "Donut."



The current and previous ILSAC standards and API Service Categories are listed here. Vehicle owners should refer to their owner's manuals before consulting these charts. Oils may have more than one performance level.

For automotive gasoline engines, the latest ILSAC standard or API Service Category includes the performance properties of each earlier category and can be used to service older engines where earlier category oils were recommended.

ILSAC STANDARD FOR PASSENGER CAR ENGINE OILS		
NAME	STATUS	SERVICE
GF-5	CURRENT	Introduced in October 2010 for 2011 and older vehicles, designed to provide improved high temperature deposit protection for pistons and turbochargers, more stringent sludge control, improved fuel economy, enhanced emission control system compatibility, seal compatibility, and protection of engines operating on ethanol-containing fuels up to E85.
GF-4	OBSOLETE	Valid until September 30, 2011. Use GF-5 where GF-4 is recommended.
GF-3	OBSOLETE	Use GF-5 where GF-3 is recommended.
GF-2	OBSOLETE	Use GF-5 where GF-2 is recommended.
GF-1	OBSOLETE	Use GF-5 where GF-1 is recommended.

GASOLINE ENGINES (FOLLOW YOUR VEHICLE MANUFACTURER'S RECOMMENDATIONS ON OIL PERFORMANCE LEVEL)		
CATEGORY	STATUS	SERVICE
SN	CURRENT	Introduced in October 2010 for 2011 and older vehicles, designed to provide improved high temperature deposit protection for pistons, more stringent sludge control, and seal compatibility. API SN with Resource Conserving matches ILSAC GF-5 by combining API SN performance with improved fuel economy, turbocharger protection, emission control system compatibility, and protection of engines operating on ethanol-containing fuels up to E85.
SM	CURRENT	For 2010 and older automotive engines.
SL	CURRENT	For 2004 and older automotive engines.
SJ	CURRENT	For 2001 and older automotive engines.
SH	OBSOLETE	
SG	OBSOLETE	
SF	OBSOLETE	
SE	OBSOLETE	CAUTION: Not suitable for use in gasoline-powered automotive engines built after 1979.
SD	OBSOLETE	CAUTION: Not suitable for use in gasoline-powered automotive engines built after 1971. Use in more modern engines may cause unsatisfactory performance or equipment harm.
SC	OBSOLETE	CAUTION: Not suitable for use in gasoline-powered automotive engines built after 1967. Use in more modern engines may cause unsatisfactory performance or equipment harm.
SB	OBSOLETE	CAUTION: Not suitable for use in gasoline-powered automotive engines built after 1951. Use in more modern engines may cause unsatisfactory performance or equipment harm.
SA	OBSOLETE	CAUTION: Contains no additives. Not suitable for use in gasoline-powered automotive engines built after 1930. Use in more modern engines may cause unsatisfactory performance or equipment harm.

AMERICAN PETROLEUM INSTITUTE | ENGINE OIL LICENSING AND CERTIFICATION SYSTEM
 1220 L Street, NW | Washington, DC 20005-4070 | USA | Sales: 713-964-2662 | Service: 202-682-8516 | Fax: 202-952-4739 | Email: eolcs@api.org | www.api.org/eolcs
 Copyright 2010 - American Petroleum Institute, all rights reserved, API, the API logo, the API Service Symbol (Donut), the API Service Symbol with CH4 PLUS logo and the API Certification Mark (Starburst) are either trademarks or registered trademarks of API in the United States and/or other countries. API Communications: 2010-140 | 12.02.10 | PDF

Response to 232-2 and 237-4

Kevin Ferrick

API

1220 L Street, NW

Washington, DC 20005

ferrick@api.org

API supports the current language in Handbook 130 paragraphs 2.33.1.4.1 and 3.13.1.4.1 approved at the July 2012 National Conference on Weights and Measures meeting. In response to the comments received in support of new items 232-2 and 237-4, we offer the following comments for consideration.

- *“Older, specialty, and some non-American vehicles take engine oil not listed as active under API’s private regulatory scheme”*
 - API’s Engine Oil Licensing and Certification System is a voluntary program based on consensus-based industry standards; it’s not a private regulatory scheme.
 - API and ILSAC standards are developed in cooperation with OEMs, oil marketers, additive companies, test labs, and other interested parties. This includes AOCA.
 - API declares categories obsolete when the tests used to verify those levels of performance no longer exist.
 - For example, API SG was in use through 1993, but the engine tests used to measure SG performance are no longer available. The engine manufacturers stopped making the engines and parts used by the tests.
 - Without SG engine tests, oil marketers might be able to refer to old SG data to confirm an SG oil’s ability to protect against wear and prevent sludge and varnish. Marketers seeking to develop new SG formulations don’t have SG engine tests to verify performance.
- *“If OEMs recommend those engine oils for their vehicles, consumers have a right to use them regardless of API’s blessing, and installers and retailers should be able to sell them without obstruction”*
 - API doesn’t recommend engine oils for vehicles—OEMs do.
 - Most US, Japanese and South Korean OEMs recommend oils licensed to use the API Starburst.
 - The Starburst identifies oils meeting the most recent ILSAC performance standard. Today, that’s GF-5. If the Starburst appears in an owner’s manual, the OEM is recommending the vehicle owner use GF-5.
 - The Starburst system is possible because oils meeting ILSAC standards are backward compatible: the latest ILSAC standard meets or exceeds the previous standard. If an owner’s manual for a 1998 model year vehicle includes the Starburst, the OEM is recommending the owner use the latest ILSAC standard (in this case GF-5).

- If an installer stocks in bulk an oil meeting an older API performance standard (for example API SF), how would the installer ensure this older oil is not installed in a newer engine unless the installer follows the requirements in the approved National Conference language?
- *“The average fast lube customer doesn’t recognize API or SAE to mean anything in particular”*
 - We agree—that’s why API launched a new program to educate marketers, distributors, installers and consumers on the importance of oil quality.
 - This includes educating everyone on the meaning of the API Starburst and Donut.
- *“When API publishes a new edition of 1509 and/or creates a new service category, a reasonable phase-in period for bulk oil stock is necessary to accommodate older vehicle owners’ needs”*
 - API provides a phase-in for all new API Starburst and Donut performance standards.
 - We start with a six- to nine-month waiting period before API begins licensing oils against the standard.
 - This is followed by a one-year period when the previous and new standards co-exist.
 - Then, according to OEM recommendations, consumers with a Starburst in their owner’s manual are recommended to start using oil’s meeting the new standard.
 - API does maintain older standards where possible. Currently, three older “S” categories (SJ, SL, and SM) can still be licensed. This is possible because the engine tests for these categories are still available.
- *“Although it is common for API to retain a couple of the most recent service categories as “active,” API could choose to make all but the most recent service category “obsolete”*
 - API declares service categories obsolete when the tests used to verify their performance are no longer available.
 - If API were to consider making a category obsolete while the engine tests were still available, API would need to ballot the change through our consensus-based standards-setting process.
- *“And what about packaged engine oil products already on the shelf or in the distribution chain when API makes a unilateral decision to deactivate an engine oil category?”*
 - API-licensed products packaged before category obsolescence are considered licensed after the obsolescence date. We can verify date of manufacture through the oil bottle’s traceability code. All packaged API-licensed oils are required to include traceability codes.
 - Unilateral decision? No tests available results in category obsolescence.

Appendix D

Handbook 130 – Uniform Regulation for Method of Sale of Commodities

Items:

Item 232-5: 2.XX. Retail Sale of Electricity/Vehicle

Table of Contents	
Items	L&R Appendix D – Page
Draft NIST Handbook 130, Method of Sale for Electricity as Vehicle Fuel	3
NIST Status Report, NIST U.S. National Work Group on Measuring Systems for Electric Vehicle Fueling and Submetering, January 23, 2013	6
Industry Letter to NCWM and L&R Committee, Amendments to 232-5 – Section 2.XX. Retail Sale of Electricity/Vehicle	7

THIS PAGE INTENTIONALLY LEFT BLANK

Draft NIST Handbook 130 Method of Sale for Electricity as Vehicle Fuel

B. Uniform Regulation for the Method of Sale of Commodities

as adopted by
The National Conference on Weights and Measures*

1. Background

The National Conference on Weights and Measures (NCWM) has long been concerned with the proper units of measurement to be used in the sale of all commodities. This approach has gradually broadened to concerns of standardized package sizes and general identity of particular commodities. Requirements for individual products were at one time made a part of the Weights and Measures Law or were embodied in separate individual Model Regulations. In 1971, this “Model State Method of Sale of Commodities Regulation” was established (renamed in 1983); amendments have been adopted by the Conference almost annually since that time.

Sections with “added 1971” dates refer to those sections that were originally incorporated in the Weights and Measures Law or in individual Model Regulations recommended by the NCWM. Subsequent dates reflect the actual amendment or addition dates.

The 1979 edition included for the first time requirements for items packaged in quantities of the International System of Units (SI), the modernized metric system, as well as continuing to present requirements for inch-pound quantities. It should be stressed that nothing in this Regulation requires changing to the SI system of measurement. SI values are given for the guidance of those wishing to adopt new SI quantities of the commodities governed by this Regulation. SI means the International System of Units as established in 1960 by the General Conference on Weights and Measures and interpreted or modified for the United States by the Secretary of Commerce.

This Regulation assimilates all of the actions periodically taken by the Conference with respect to certain food items, non-food items, and general method of sale concepts. Its format is such that it will permit the addition of individual items at the end of appropriate sections as the need arises. Its adoption as a regulation by individual jurisdictions will eliminate the necessity for legislative consideration of changes in the method of sale of particular commodities. Such items will be able to be handled through the normal regulation-making process.

2. Status of Promulgation

The table beginning on page 10 shows the status of adoption of the Uniform Regulation for the Method of Sale of Commodities.

**The National Conference on Weights and Measures (NCWM) is supported by the National Institute of Standards and Technology (NIST) in partial implementation of its statutory responsibility for “cooperation with the states in securing uniformity in weights and measures laws and methods of inspection.”*

Uniform Regulation for the Method of Sale of Commodities

Section 2. Non-food Products ^[NOTE 1, page 107]

2.XX. Retail Sales of Electricity Sold as a Vehicle Fuel.

2.XX.1. Definitions.

2.XX.1.1. Electricity sold as vehicle fuel. – Electrical energy transferred to and/or stored onboard an electric vehicle primarily for the purpose of propulsion.

2.XX.1.2. Electric vehicle supply equipment (EVSE). – The conductors, including the ungrounded, grounded, and equipment grounding conductors; the electric vehicle connectors; attachment plugs; and all other fittings, devices, power outlets, or apparatuses installed specifically for the purpose of measuring, delivering, and computing the price of electrical energy delivered to the electric vehicle.

2.XX.1.3. Fixed service. – Service that continuously provides the nominal power that is possible with the equipment as it is installed.

2.XX.1.4. Variable service. – Service that may be controlled resulting in periods of reduced, and/or interrupted transfer of electrical energy.

2.XX.1.5. Nominal Power. – Refers to the “intended” or “named” or “stated” as opposed to “actual” rate of transfer of electrical energy (i.e., power).

2.XX.2. Method of Retail Sale. – All electrical energy kept, offered, or exposed for sale and sold at retail as a vehicle fuel shall be in units in terms of the megajoule (MJ) or kilowatt-hour (kWh). In addition to the fee assessed for the quantity of electrical energy sold, fees may be assessed for other services; such fees may be based on time measurement and/or a fixed fee.

2.XX.3. Retail Electric Vehicle Supply Equipment (EVSE) Labeling.

- (a) A computing EVSE shall display the unit price in whole cents (e.g., \$0.12) or tenths of one cent (e.g., \$0.119) on the basis of price per megajoule (MJ) or kilowatt-hour (kWh). In cases where the electrical energy is unlimited or free of charge, this fact shall be clearly indicated in place of the unit price.
- (b) For fixed service applications, the following information shall be conspicuously displayed or posted on the face of the device:
 - (1) the level of EV Service expressed as the nominal power transfer (i.e., nominal rate of electrical energy transfer), and
 - (2) the type of electrical energy transfer (e.g., AC, DC, wireless, etc.).
- (c) For variable service applications, the following information shall be conspicuously displayed or posted on the face of the device:
 - (1) the type of service (i.e., “Variable”);
 - (2) the minimum and maximum power transfer that can occur during a transaction, including whether service can be reduced to zero;
 - (3) the conditions under which variations in electrical energy transfer will occur; and
 - (4) the type of electrical energy transfer (e.g., AC, DC, wireless, etc.).
- (d) Where fees will be assessed for other services in direct connection with the fueling of the vehicle, such as fees based on time measurement and/or a fixed fee, the additional fees shall be displayed.

- (e) The EVSE shall be labeled in accordance with 16 CFR, PART 309 – FTC Labeling Requirements for Alternative Fuels and Alternative Fueled Vehicles.
- (f) The EVSE shall be listed and labeled in accordance with the National Electric Code[®] (NEC) NFPA 70, Article 625 Electric Vehicle Charging Systems (www.nfpa.org).

2.XX.4. Street Sign Prices and Other Advertisements.

Where electrical energy unit price information is presented on street signs or in advertising other than on the EVSE:

- (a) The electrical energy unit price shall be in terms of price per megajoule (MJ) or kilowatt-hour (kWh) in whole cents (e.g., \$0.12) or tenths of one cent (e.g., \$0.119). In cases where the electrical energy is unlimited or free of charge, this fact shall be clearly indicated in place of the unit price.
- (b) In cases where more than one electrical energy unit price may apply over the duration of a single transaction to sales to the general public, the terms and conditions that will determine each unit price and when each unit price will apply shall be clearly displayed.
- (c) For fixed service applications, the following information shall be conspicuously displayed or posted:
 - (1) the level of EV Service expressed as the nominal power transfer (i.e., nominal rate of electrical energy transfer), and
 - (2) the type of electrical energy transfer (e.g., AC, DC, wireless, etc.).
- (d) For variable service applications, the following information shall be conspicuously displayed or posted:
 - (1) the type of delivery (i.e., “Variable”);
 - (2) the minimum and maximum power transfer that can occur during a transaction, including whether service can be reduced to zero;
 - (3) the conditions under which variations in electrical energy transfer will occur; and
 - (4) the type of electrical energy transfer (e.g., AC, DC, wireless, etc.).

Where fees will be assessed for other services in direct connection with the fueling of the vehicle, such as fees based on time measurement and/or a fixed fee, the additional fees shall be included on all street signs or other advertising.

(Added 20XX)

NIST Status Report
[1/23/13]

Group: NIST U.S. National Work Group on Measuring Systems for Electric Vehicle Fueling and Submetering (USNWG EVF&S)

Scope and Purpose: In August 2012, NIST formed the USNWG EVF&S to develop proposed requirements for commercial electricity-measuring devices (including those used in sub-metering electricity at residential and business locations and those used to measure and sell electricity dispensed as a vehicle fuel) and to ensure that the prescribed methodologies and standards facilitate measurements that are traceable to the International System of Units (SI). This work is not intended to address utility metering in the home or business where the metered electricity is consumed by the end purchaser and that falls under the authority of entities such as the local utility commission.

Meetings: On August 29, 2012, the USNWG held its first meeting via web conference. During this meeting, USNWG administrative issues and structure were covered.

In November 2012, NIST OWM prepared and distributed draft proposals for method of sale requirements (for inclusion in NIST HB 130) and a device code (for inclusion in NIST HB 44) to USNWG members.

Based on comments received, NIST OWM prepared updated drafts of these proposals and distributed them at a second USNWG meeting held January 15-17, 2013 at NIST in Gaithersburg, MD. Of the 35 total attendees, 18 USNWG members and 6 NIST OWM staff members attended in person, while 11 USNWG members attended online. Attendees included representatives from:

- vehicle charging equipment and electric meter manufacturers,
- State and local weights and measures jurisdictions,
- energy distribution companies and service providers,
- national laboratories,
- technical committees (e.g., the ANSI C12 Chair),
- standards organizations (i.e., UL and NEMA),
- NIST OWM and NIST Smart Grid Interoperability Panel.

After reviewing and revising the method of sale proposal during the meeting, the USNWG voted 12 to 1 to recommend to the NCWM L&R Committee that the proposal be presented for voting. The USNWG recognized that some members need to further vet the revised proposal within their organizations, but expects this process to be complete within the next few weeks. Any changes would be forwarded to the L&R Committee in time for inclusion in NCWM Publication 16. The USNWG will continue its review of the device code at its next meeting, which will be scheduled via web conference in the near future.

During the meeting, a subcommittee to develop methods and equipment needs for field testing EV charging devices was also formed.

Input Needed:

The USNWG encourages review and input on the draft MOS proposal as well as the draft device code.

Contacts:

Technical Advisor: Marc Buttler, NIST OWM; Tel: 301-975-4615; Email: marc.buttler@nist.gov

Chair: Juana Williams, NIST OWM; Tel: 301-975-3989; Email: juana.williams@nist.gov

Industry Letter to NCWM and L&R Committee

Amendment to 232-5 – Section 2.XX. Retail Sale of Electricity/Vehicle

On behalf of a coalition of industry stakeholders¹, I offer an amendment to the text contained in Publication 16 (beginning on page L&R 32).

This same coalition submitted a letter to the L&R Committee on 12 July 2013 (**see Appendix A**). **Committee members should not interpret Friday's letter as an endorsement of 232-5 as printed in Publication 16.**

In fact, the coalition letter was written with the understanding that the 11 June 2013 version of the draft uniform regulation would be considered today. That version reflects the most recent work of the NIST U.S. National Work Group on Measuring Systems for Electric Vehicle Fueling and Submetering (NIST National Work Group).

Specifically, the NIST Status Report dated 19 June 2013 states:

Based on the results of this vote, the USNWG recommends that the NCWM L&R Committee replace the proposal in the 2013 Publication 16 L&R Interim Meeting Report Item 232-5 with the following prior to voting on the item at the NCWM. **(Appendix B)**

Many of the industry stakeholders cited below are a part of the NIST National Work Group and have been active participants throughout the language development process.

In its most recent meeting on June 11, the NIST National Work Group amended the language contained in Publication 16. Our group of industry stakeholders was and is supportive of the amended version (**Appendix B**).

The amendment I offer today is to replace what is contained in Publication 16 with the language approved by the NIST National Work Group at its June 11 meeting.

This language can be found on page 3 of **Appendix B**.

¹ American Public Power Association, Auto Alliance, ChargePoint, Delta Products Corporation, ECotality, Edison Electric Institute, Electric Drive Transportation Association, eVgo, Fuji Electric, Global Automakers, National Association of Convenience Stores, NATSO (representing America's Travel Plazas and Truck Stops), National Electrical Manufacturers Association, and NRG Energy.

APPENDIX A

July 12, 2013

Ms. Judy Cardin, Chair
Laws and Regulations Committee
National Conference on Weights and Measures
1135 M Street, Suite 110
Lincoln, Nebraska 68508

Dear Chair Cardin:

The undersigned write to express our support for the revisions to NIST Handbook 130 recommended by the U.S. National Work Group on Measuring Systems for Electric Vehicle Fueling and Submetering (USNWG) pertaining to method of sale.

We appreciate the opportunity to share with the Laws and Regulations (L&R) Committee the viewpoint of industry stakeholders. We believe that the sustainable adoption of electric vehicles (EV) requires the deployment of commercially viable electric vehicle supply equipment (EVSE).

Many of our companies and organizations actively participated in the USNWG's deliberations. The dialogue allowed many different voices to be heard and complex questions to be discussed and clarified. The staff at NIST and all participants should be commended for their efforts in developing this recommendation for the L&R Committee.

Both industry and the consumer segment represented in the USNWG supported the language as submitted by the USNWG to the L&R Committee. The recommended language enables multiple business models for providing electric vehicle charging services, which, consistent with national energy policies, will increase the availability of convenient charging facilities by promoting more widespread adoption of EVSE.² This also puts the EV driver in control of his or her recharging needs.

By allowing for other appropriate business models in the case of charging services offered to consumers through retail sales methods based on non-energy units (2.XX.2.2), Electric Vehicle Service Providers (EVSP) are not precluded from offering recharging services based on mileage, membership, time, place or other factors. Importantly, approximately 80% of the states do not permit the resale of electricity and these other business models enable the adoption of electric vehicle charging stations in those markets.

At the same time, the proposed regulation also allows for a method of sale for those EVSP who wish to price their services based on the quantity of electricity delivered to the customer.

The services that have formed around recharging an EV are still in their early stages, with market participants offering many different types of recharging services. Innovative companies are providing great value to the EV driver in ways that bear little resemblance to the gasoline

² See U.S. Department of Energy, One Million Electric Vehicles by 2015, February 2011 Status Report (noting "Uncertainties about EVs— including their resale value, range and availability of convenient charging facilities -- may impose sales barriers."). Available at: http://www1.eere.energy.gov/vehiclesandfuels/pdfs/1_million_electric_vehicles_rpt.pdf

station model. Recharging an EV is an entirely different experience in areas such as where, how long, and how often recharging takes place and the many new communication features available between the vehicle, the EVSE, the EVSP, and the driver.

This is why we had been concerned with earlier versions of the draft regulation that appeared to be largely based on the existing uniform regulation for petroleum-based fuels. Requiring that “all electrical energy kept, offered, or exposed for sale and sold at retail as a vehicle fuel shall be in units in terms of the megajoule (MJ) or kilowatt-hour (kWh)” would stifle innovation in this market sector, require a submeter on each and every EVSE, and drive up the cost of these products in an industry that is still seeding the market.

Moreover, there is no additional consumer protection benefit to adopting an overly restrictive method of sale, because today’s technology enables customers to know vast amounts of information about the charging of their vehicles.

On June 11, when the USNWG voted favorably to report this draft regulation to the NCWM, nearly all votes against the draft regulation came from members of the NCWM. At the same time, virtually all other participants cast a vote for the draft regulation. We hope this letter gives the L&R Committee a clear view of the reasons behind our support.

We, the undersigned, share the goal of creating a market that offers maximum choice and minimum cost to the EV driver. We believe a draft uniform regulation which preserves competition and innovation will help to achieve this goal.

We urge the L&R Committee to approve this draft regulation. Sincerely,





The power to change life.™

APPENDIX B

NIST Status Report *[6/19/13]*

Group: NIST U.S. National Work Group on Measuring Systems for Electric Vehicle Fueling and Submetering
(USNWG EVF&S)

Scope and Purpose: In August 2012, NIST formed the USNWG EVF&S to develop proposed requirements for commercial electrical energy-measuring devices (including those used in submetering electrical energy at residential and business locations and those used to measure and sell electrical energy dispensed as a vehicle fuel) and to ensure that the prescribed methodologies and standards facilitate measurements that are traceable to the International System of Units (SI). This work is not intended to address utility metering in the home or business where the metered electricity is consumed by the end purchaser and that falls under the authority of entities such as the local utility commission.

Membership: USNWG members include representatives from:

- vehicle charging equipment and electric meter manufacturers,
- State and local weights and measures jurisdictions,
- energy distribution companies and service providers,
- national laboratories,
- technical committees (e.g., the ANSI C12 Chair),
- standards organizations (i.e., UL and NEMA),
- NIST OWM and NIST Smart Grid Interoperability Panel.

Meetings:

The USNWG has met a total of five times.

In November 2012, NIST OWM prepared and distributed to the USNWG draft proposals for a method of sale (MOS) regulation (for inclusion in NIST HB 130) for electric vehicle refueling and a device code (for inclusion in NIST HB 44) that addresses both electric vehicle refueling and submeter applications.

At its January 15-17, 2013 meeting, the USNWG voted 12 to 1 to recommend to the NCWM L&R Committee that the proposed new HB 130 MOS regulation be presented for a vote during the July 2013 NCWM. The MOS proposal addresses: (1) method of sale; (2) unit price display; (3) identification of the service levels; (4) additional fees connected to charging; (5) device labeling; (6) street signs and other advertising; and (7) related definitions.

Following the January meeting, USNWG members provided comments and suggested changes after vetting the HB 130 MOS proposal within their organizations.

At its June 11, 2013 meeting, the USNWG discussed modifications to its original HB 130 MOS proposal:

1. A modified proposal based on those comments which had been received between January 28, 2013 and May 30, 2013 that might be considered “minor” changes was prepared for the USNWG to consider during its June 2013 meeting. These suggested “minor” modifications were intended to:
 - Clarify that the MOS does not apply where no fees are associated with the delivery or distribution of electrical energy.
 - Reword the definition of the term **Electrical Energy Sold as Vehicle Fuel** to enhance clarity.
 - Remove the option to display the unit price in tenths of one cent and require that the unit price be display only in units of whole cents.

- Include wording to clarify that the labeling and signage requirements for communicating the terms of “variable service” are intended to apply only to those conditions affecting service which are “under the direct control of the seller.”
- Include the requirement that the display of any additional fees shall also include the basis for those fees.
- Clarify that EVSE products shall be listed with a nationally recognized test laboratory (NRTL) and shall be “installed” (instead of merely being “labeled”) in accordance with the National Electric Code (NEC).
- Recognize that street signs and advertising may appear either directly on or “in close proximity to” an EVSE.

The USNWG did not vote on this version, but proceeded to discuss and vote on the amendment to the scope described in Item 2 because members disagreed on the scope of the MOS.

2. During the meeting, an alternate proposal was made to modify the scope of the MOS to allow more than one method of sale. The proposed alternative would not require disclosure of the quantity of the electrical energy delivered to a consumer, as is currently provided when purchasing electrical energy from a utility or through submetering applications. Specifically, the proposal was to add the following language to paragraph **2.XX. Retail Sales of Electrical Energy Sold as a Vehicle Fuel**:

This section does not apply to sales of electric vehicle charging services where the electric vehicle user is provided unlimited access to electric vehicle charging services or where the electrical energy is free, as in the case where the fee assessed is wholly independent of the quantity of electrical energy delivered.

The amendment to modify the scope of the application of the MOS was adopted based on the results of the voting on the amendment shown below.

Voting Results on the Amendment to the June 11, 2013 Modified Proposal			
Sector	In Favor	Opposed	Total
Industry	9	1	10
National Laboratories	2	0	2
Consumer Advocacy	1	0	1
Weights and Measures Officials	0	6	6
Total	12	7	19

3. The USNWG voted on a modified version of the MOS proposal, including the revised scope as outlined in Item 2 above. This modified proposal was supported by a majority vote of the USNWG during the June 11, 2013 meeting with the following results.

Voting Results on the June 11, 2013 Modified Proposal as Amended			
Sector	In Favor	Opposed	Total
Industry	9	2	11
National Laboratories	2	0	2
Consumer Advocacy	1	0	1
Weights and Measures Officials	0	6	6
Total	12	8	20

Based on the results of this vote, the USNWG recommends that the NCWM L&R Committee replace the proposal in the 2013 Publication 16 L&R Interim Meeting Report Item 232-5 with the following prior to voting on the item at the NCWM.

B. Uniform Regulation for the Method of Sale of Commodities

Section 2. Non-food Products ^[NOTE 1, page 107]

2.XX. Retail Sales of Electrical Energy Sold as a Vehicle Fuel. This section does not apply to sales of electric vehicle charging services where the electric vehicle user is provided unlimited access to electric vehicle charging services or where the electrical energy is free, as in the case where the fee assessed is wholly independent of the quantity of electrical energy delivered.

2.XX.1. Definitions.

2.XX.1.1. Electrical Energy sold as vehicle fuel. – Electrical energy kept, offered or exposed for sale and sold at retail as a vehicle fuel and transferred to an electric vehicle primarily for the purpose of propulsion and/or energizing the vehicle.

2.XX.1.2. Electric vehicle supply equipment (EVSE). – The conductors, including the ungrounded, grounded, and equipment grounding conductors; the electric vehicle connectors; attachment plugs; and all other fittings, devices, power outlets, or apparatuses installed specifically for the purpose of measuring, delivering, and computing the price of electrical energy delivered to the electric vehicle.

2.XX.1.3. Fixed service. – Service that continuously provides the nominal power that is possible with the equipment as it is installed.

2.XX.1.4. Variable service. – Service that may be controlled resulting in periods of reduced, and/or interrupted transfer of electrical energy.

2.XX.1.5. Nominal power. – Refers to the “intended ” or “named ” or “stated ” as opposed to “actual” rate of transfer of electrical energy (i.e., power).

2.XX.2. Method of Retail Sale. – All electrical energy kept, offered, or exposed for sale and sold at retail as a vehicle fuel shall be in units in terms of the megajoule (MJ) or kilowatt -hour (kWh). In addition to the fee assessed for the quantity of electrical energy sold, fees may be assessed for other services; such additional fees may be based on time measurement and/or a fixed fee.

2.XX.3. Retail Electric Vehicle Supply Equipment (EVSE) Labeling.

- (a) A computing EVSE shall display the unit price in whole cents (e.g., \$0.12) on the basis of price per megajoule (MJ) or kilowatt-hour (kWh).
- (b) For fixed service applications, the following information shall be conspicuously displayed or posted on the face of the device:
 - (1) the level of EV Service expressed as the nominal power transfer (i.e., nominal rate of electrical energy transfer), and
 - (2) the type of electrical energy transfer (e.g., AC, DC, wireless, etc.)
- (c) For variable service applications, the following information shall be conspicuously displayed or posted on the face of the device:
 - (1) the type of service (i.e., “Variable”);
 - (2) the minimum and maximum power transfer that can occur during a transaction as a result of direct control by the seller, including whether service can be reduced to zero;

- (3) the conditions under which variations in electrical energy transfer will occur as a result of direct control by the seller; and
- (4) the type of electrical energy transfer (e.g., AC, DC, wireless, etc.).

- (d) Where fees will be assessed for other services in direct connection with the fueling of the vehicle, such as fees based on time measurement and/or a fixed fee, the additional fees shall be displayed along with the basis for the fee.

- (e) The EVSE shall be labeled in accordance with 16 CFR, PART 309 – FTC Labeling Requirements for Alternative Fuels and Alternative Fueled Vehicles.

- (f) The EVSE shall be listed by a nationally recognized test laboratory (NRTL) and installed in accordance with the National Electric Code® (NEC) NFPA 70, Article 625 Electric Vehicle Charging Systems (www.nfpa.org).

2.XX.4. Street Sign Prices and Other Advertisements.

Where electrical energy unit price information is presented on street signs or in advertising other than on or in close proximity to the EVSE:

- (a) The electrical energy unit price shall be in terms of price per megajoule (MJ) or kilowatt -hour (kWh) in whole cents (e.g., \$0.12).

- (b) In cases where more than one electrical energy unit price may apply over the duration of a single transaction to sales to the general public, the terms and conditions that will determine each unit price and when each unit price will apply shall be clearly displayed.

- (c) For fixed service applications, the following information shall be conspicuously displayed or posted:
 - (1) the level of EV Service expressed as the nominal power transfer (i.e., nominal rate of electrical energy transfer), and
 - (2) the type of electrical energy transfer (e.g., AC, DC, wireless, etc.).

- (d) For variable service applications, the following information shall be conspicuously displayed or posted:
 - (1) the type of delivery (i.e., “Variable”);
 - (2) the minimum and maximum power transfer that can occur during a transaction as a result of direct control by the seller, including whether service can be reduced to zero;
 - (3) the conditions under which variations in electrical energy transfer will occur as a result of direct control by the seller; and
 - (4) the type of electrical energy transfer (e.g., AC, DC, wireless, etc.).

Where fees will be assessed for other services in direct connection with the fueling of the vehicle, such as fees based on time measurement and/or a fixed fee, the additional fees shall be included on all street signs or other advertising.

(Added 20XX)

Input Needed: The USNWG requests input from the L&R Committee and NCWM members on whether a MOS proposal that would allow more than one method of sale for electrical energy would be acceptable.

Contacts: Technical Advisor: Marc Buttler, NIST OWM; Tel: 301-975-4615; Email: marc.buttler@nist.gov

Chair: Juana Williams, NIST OWM; Tel: 301-975-3989; Email: juana.williams@nist.gov

Appendix E

Handbook 130 – Uniform Regulation Engine Fuels and Automotive Lubricants Regulation

Items:

- Item 237-2:** 1.1.3. Minimum Antiknock Index (AKI),
2.1.4. Minimum Motor Octane Number, and
3.2.5. Prohibition of Terms – Table 1

Table of Contents	
Items	L&R Appendix E – Page
Mercury Marine, January 21, 2013	3
Global Automakers, January 24, 2013	4
Alliance of Automobile Manufacturers Statement, January 27, 2013	6
ExxonMobil (U.S.), Win Gardner	7
Ford Motor Company Statement, January 27, 2013	9
General Motors, Bill Studzinski (presentation), January 27 - 31, 2013	10

THIS PAGE INTENTIONALLY LEFT BLANK



January 21, 2013 ¶

¶
To the Members of the National Council of Weights and Measures: ¶

¶
Ballot (Form 15) to modify U.S. Gasoline Octane Specifications in Handbook 130 ¶

¶
The purpose of this letter is to state the official position of Mercury Marine regarding the minimum octane rating of pump fuels available in the United States. ¶

¶
Mercury Marine produces marine propulsion engines for use in a wide variety of recreational, commercial, and government applications. These engines employ a range of technologies. Many products make use of electronic engine controls featuring fuel injection (both port and direct), pressure charging, and knock control systems. All of Mercury Marine's products are designed to be operated on gasoline with a minimum rating of 87 AKI or higher. As such, these engines are calibrated to achieve maximum performance at all operating loads on this fuel. On engines with knock control systems, the use of lower grades of gasoline will reduce performance. The use of lower grades of gasoline in engines without knock control could cause increased levels of knock, potentially damaging internal engine components. ¶

¶
The fuel specification in Mercury Marine's owner's manuals includes a minimum octane rating of 87 AKI, regardless of operating altitude. Further, the manuals state that the use of improper fuels can cause engine damage, and that damage caused by the use of improper fuels may not be covered by the engine warranty. ¶

¶
Mercury Marine strongly encourages the National Council of Weights and Measures to amend the U.S. Octane Specification to require a minimum octane rating of 87 AKI, regardless of altitude. ¶

Respectfully, ¶

¶
Jeff Broman ¶

Technical Specialist -- Engine Thermodynamics ¶

Product Development & Engineering ¶

Mercury Marine ¶

¶

Mercury Marine Marine Products and Services

W6250 Pioneer Road / P.O. Box 1939 / Fond du Lac, WI 54936-1939 USA / PH 920-929-5000 / www.mercurymarine.com



Aston Martin • Ferrari • Honda • Hyundai • Isuzu • Kia • Mahindra
Maserati • McLaren • Nissan • Peugeot • Subaru • Suzuki • Toyota

January 24, 2013

National Conference of Weights & Measures
1135 M Street, Suite 110
Lincoln, NE 68508

Re: Amendments to Handbook 130 Regarding Minimum Octane of 87 AKI for Gasoline

Dear Sir or Madam:

The Association of Global Automakers represents international motor vehicle manufacturers, original equipment suppliers, and other automotive-related trade associations.¹ Global Automakers works with industry leaders, legislators, regulators, and other stakeholders in the United States to create public policies that improve motor vehicle safety, encourage technological innovation and protect our planet. Our goal is to foster an open and competitive automotive marketplace that encourages investment, job growth, and development of vehicles that can enhance Americans' quality of life.

We understand that the NCWM will be meeting on January 27-30, 2013 and, among other business, will be considering proposed amendments to Handbook 130. The purpose of this letter is to advise you of our support for amendments to Handbook 130 to set minimum octane requirements for gasoline at 87 AKI (anti-knock index) for gasoline sold throughout the United States. All Global Automakers' members and, in fact, all auto manufacturers selling vehicles in the U.S., stipulate minimum octane levels for their products in their owner's manuals for current vehicles at 87 octane AKI throughout the entirety of the U.S. Some higher performance models may require higher octane levels. We are working with the ASTM D02 committee (Petroleum Products and Lubricants) to effect the same amendments in the ASTM D4814 Standard Specification for Automotive Spark-Ignition Engine Fuel. We fully support these amendments to Handbook 130 as soon as possible.

Consumers' investments in their vehicles are usually second only to the investments they make in their homes. Using off-specification gasoline from that recommended by the vehicle manufacturer puts these investments at risk, increases emissions, and erodes fuel economy. It is in the best interests of the motoring public and the public interest to set minimum specifications in Handbook 130 which are consistent with the fuels recommended by auto manufacturers.

¹ Our members include American Honda Motor Co., American Suzuki Motor Corp., Aston Martin Lagonda of North America, Inc., Ferrari North America, Inc., Hyundai Motor America, Isuzu Motors America, Inc., Kia Motors America, Inc., Mahindra & Mahindra Ltd., Maserati North America, Inc., McLaren Automotive Ltd., Nissan North America, Inc. Peugeot Motors of America, Subaru of America, Inc. and Toyota Motor North America, Inc. For more information, visit www.globalautomakers.org.



Thank you for your consideration and support of this request. Please direct any questions to John Cabaniss, Director, Environment & Energy, (202) 650-5562 or icabaniss@globalautomakers.org.

Sincerely,

A handwritten signature in black ink that reads "Michael J. Stanton".

Michael J. Stanton
President & CEO

National Council of Weights and Measures

Interim Meeting

January 27, 2013

Charleston, South Carolina

Alliance of Automobile Manufacturers Statement
Re: Gasoline Octane De-rating for High Altitudes

My name is Valerie Ughetta, and I am Director for Automotive Fuels at the Alliance of Automobile Manufacturers. The Alliance is the leading advocacy group for the auto industry, representing 77% of all car and light truck sales in the United States. Members include BMW Group, Chrysler Group LLC, Ford Motor Company, General Motors Company, Jaguar Land Rover, Mazda, Mercedes-Benz USA, Mitsubishi Motors, Porsche, Toyota, Volkswagen Group of America, and Volvo Cars North America. Our website can be found at www.autoalliance.org.

Alliance Members strongly support a review of national consensus standards with regard to provisions that allow so-called Octane De-rating for Altitude. Without exception, all automakers specify the use of gasoline with a minimum octane rating of 87 AKI (Antiknock Index) in their vehicle owner's manuals. Today, post- MY 1984 vehicles are designed, calibrated, and durability-tested to run on 87 AKI or higher fuel.

A gasoline's octane rating is the number one fuel property affecting a vehicle's performance. Fuel is not merely a customer commodity, but an integral part of the vehicle system as a whole. Highly advanced fuel delivery, engine control and exhaust after-treatment systems are designed to run in a precisely engineered and optimized manner to meet challenging new environmental, fuel economy, and vehicle performance specifications. Engineering to protect against the potential use of a low octane fuel in a vehicle developed for 87 AKI or higher reduces the optimized functional capabilities of the vehicle. In short, consumers *already* need, and will continue to need nationally consistent supplies of minimum 87 AKI and higher rated octane fuels.

Efforts at ASTM and NCWM to review their gasoline specifications and standards are important and time-sensitive. States neighboring the ASTM High Altitude designated geographic areas are faced with supply, marketing, and competitive issues because of the disparity in fuel grades from high altitude states and counties, because they get their gasoline from the same limited refinery and pipeline sources. This has been playing out in South Dakota over the past year. A uniform, national minimum octane grade is warranted by the refinements in vehicle technology and is far preferable for consumers to a patchwork of state laws.

Thank you for the opportunity to comment.

For further information please contact:

Valerie Ughetta, Director, Automotive Fuels

Alliance of Automobile Manufacturers

1401 Eye Street NW Suite 900, Washington, DC 20005

vughetta@autoalliance.org

202 326 5549

My name is Win Gardner, Fuels Quality Manager for ExxonMobil in the US. We consider the proposal to amend Section 2.1.4 to eliminate the altitude adjustments for octanes to be premature at this time and recommend that the item remain informational.

ASTM is also addressing this issue and a ballot to remove the discussion regarding altitude adjustments was issued last fall and addressed at the December meeting. There were a number of negatives submitted for a variety of reasons, but predominantly because there was almost no pertinent data presented that the octane requirement adjustment for altitude was invalid. It was decided to withdraw the ballot and, instead, move forward with some scientifically designed experiments to elucidate the subject.

Let's take a look at what data is available. There are two types of data that should be considered. There's the sort of data developed via designed experiments, exemplified by CRC studies which have been used traditionally to guide the specification setting process at ASTM. While there have been no recent CRC studies on the subject of octane requirement needs of vehicles at higher altitudes, there are a number of peer reviewed scientific studies that have been published using vehicles produced during the 1990s and 2000s which confirm that an altitude adjustment for octane is still justified. These studies were conducted with many vehicles employing altitude compensation. So the data that is available, while not conducted on the most recent model years, does conclude that vehicles operating at high altitudes require a lower octane than vehicles operating at sea level.

But there's another type of data that's available, empirical data, or that type of data developed over time from practical experience. As a general rule, I prefer the data that's generated via scientific experiments. But empirical data isn't automatically invalid and one shouldn't discount it especially when there's a wealth of it available. Gasoline with octanes at 85 or 85.5 has been sold in the mountain states of Montana, Idaho, Wyoming, Utah, Colorado and South Dakota for many decades. Consumers express their satisfaction with those grades by purchasing it overwhelmingly compared with the other octane grades available. The majority of the gasoline sold in the mountain states is Regular 85 or 85.5. We are a major marketer of these gasolines and have received no complaints from our customers about the octane over the years. And, to our knowledge, the auto manufacturers have not incurred octane-related warranty issues on vehicles from this region.

While most of the sales in the mountain states are the Regular 85 grade, ExxonMobil and other companies do offer higher grades of 87 and 91 octane. So, if the auto companies choose to introduce more vehicles with turbo chargers or other technologies which require higher octane levels, those fuels are readily available at the same services stations.

I need to mention one other aspect of this issue. Octane isn't free.

I'm sure you've noticed that Premium gasoline costs more at the pump than does Regular. In my area of the country the differential is about 50 cents. A refinery, given their crude mix and processing capabilities, has a limited octane "pool" to disburse among its gasoline products. Raising the octane of a product that represents the majority of production is not easy, nor cheap. MSAT (Mobile Source Air Toxics) II recently was implemented nationwide. This EPA program required that the levels of benzene be lowered in gasolines. Benzene has high octane so removing it from the gasoline pool reduced the ability to maintain octane. Fortunately, the rapid increase in ethanol blending counteracted that decrease due to MSAT II. If a significant increase in octane is mandated in the mountain states, we expect that refineries will have to invest many millions of dollars to modify their processing units. Those modifications take several years to plan, permit and construct, so any rapid change to regulated octanes is likely to drive supply shortage issues and pressures on the cost structure. Do you really want to saddle the mountain state consumers with increased gasoline costs with essentially no data driven reason for their sacrifice?

Thank you for the opportunity to provide this testimony today. I recommend this item be maintained as informational pending ASTM action.

National Council of Weights and Measures
Interim Meeting
January 27, 2013
Charleston, South Carolina

Ford Motor Company Statement
Re: Gasoline Octane De-rating for High Altitudes

Ford Motor Company supports the review of industry gasoline standards that allow marketers to sell fuel with an octane rating below 87 (R+M)/2 as “REGULAR GRADE”. The industry practice of de-rating the octane of fuels in altitude regions is not consistent with minimum octane requirements of vehicles manufactured by Ford that are designed and calibrated to operate on 87 (R+M)/2 minimum octane at both sea level and higher altitudes.

The recommendation given in Ford’s vehicle owner guides specifies that “Fuels with octane levels below 87 are not recommended.” In addition, the use of such fuels may result in loss of vehicle performance and possible engine damage that may void warranty claims for related repairs.

In the mid 90’s, Ford raised concerns at industry meetings and held discussions with oil companies regarding a higher rate of warranty claims that were experienced by vehicle owners in altitude regions of western states, including, the Denver area. The rate of warranty claims related to spark knock complaints in Ford trucks were significantly higher in the altitude regions as compared to areas at sea level. Also, studies conducted by the Coordinating Research Council and findings reported in SAE papers in late 80’s confirmed that Ford vehicles and others had the same octane requirement, regardless of altitude.

The discussions at NCWM to review the octane issue and develop a consensus on a minimum octane standard where “REGULAR GRADE” is defined as 87 (R+M)/2 would help the auto industry meet national standards for emission, fuel economy and GHG. A consensus on a minimum octane standard that is applicable to all regions of each state will also promote improved customer satisfaction for vehicle owners as it relates to vehicle performance and durability.

If you require further information, please feel free to contact me.

Peter W. Misangyi, Supv., Fuels and Lubricants
Ford Motor Company
pmisangy@ford.com
Phone: 313-322-3543

General Motors, Bill Studzinski (presentation), January 27 - 31, 2013

2013 NCWM Interim Meeting

January 27 - 31 – Charleston, SC

L&R Item 237-2

Ballot (Form-15) to modify U.S. Gasoline Octane Specifications in Handbook 130

Applicable L&R Sections

Section 2.1.4. Minimum Antiknock Index (AKI)

Section 2.1.5. Minimum Motor Octane Number

Table 1. Minimum Antiknock Index Pump Labeling Requirements

Bill Studzinski – General Motors

1

Background and Data Supporting Item 237-2 – U.S. Gasoline Octane

- 85 and 86 Pump Octane levels were developed when carbureted cars without computer controls were predominantly in the market and subject to altitude de-rating of octane
 - Modern computer controlled cars will optimize performance to utilize the gasoline octane rating stated in the vehicle owner's manual at all altitudes
- Vehicle owners should use the gasoline octane rating stated in their owner's manual
 - All U.S. vehicles require 87 Pump Octane or greater
 - A vehicle's octane requirement is set during development to balance engine power, torque, emissions, fuel economy, durability, and emissions compliance
- Knock sensors and computer controls prevent engine damage if mild autoignition (knock) occurs but can not protect against engine damaging severe autoignition
 - Consumers most likely won't be able to hear or feel the reduced performance of mild knock
- Scoping Tests: Vehicle Octane Testing on High Altitude Emission Chassis Dyno
 - 2 vehicles instrumented with Engine Computer Module data acquisition and exhaust inlet temperature thermocouples
 - Standardized US06 Emissions Test Cycles in A-B-A pattern
 - Two fuels: 85 and 87 AKI E0 Gasoline
 - Two Altitudes: 5,400 ft and 0 ft (Sea Level)
 - Results from 85 Octane...
 - Reduced fuel economy – more significant at Sea Level
 - Increased engine load
 - Increased thermal loading on the engine and exhaust reduction components

2

Comparison of US06 Emissions Test Cycle Results Vehicle 1, Denver Altitude, 85 and 87 Pump Octane

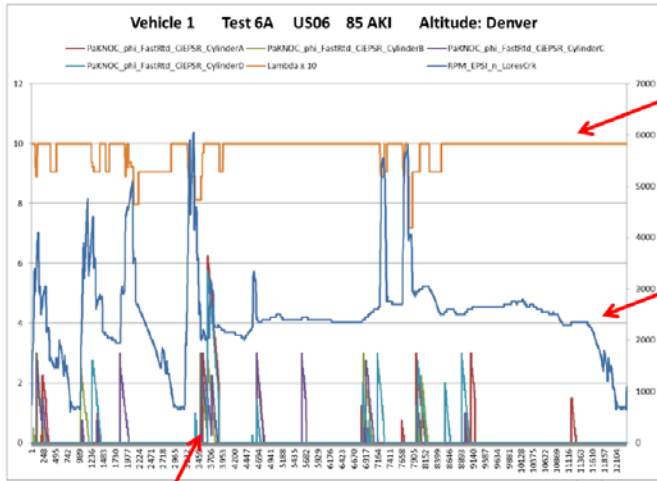

Lambda Air to Fuel Ratio x 10
 (1.0 is stoichiometric, < 1 is fuel rich)

Engine RPM

“Spark Retard” for each Cylinder
 (Reason for higher Exhaust Temps.)

Next Slide quantifies the 85
 Octane effects at Altitude.

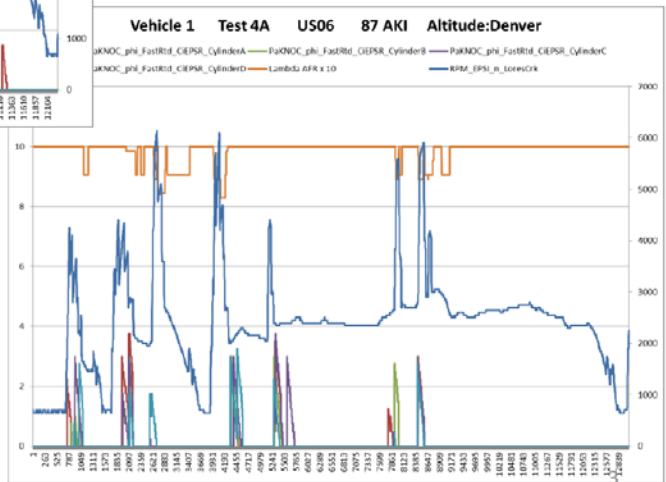

Low Octane Causes Inefficient Vehicle Operation

Vehicle Performance Benefits of 87 Pump Octane¹ Relative to 85 Octane in Standardized US06² Emissions Tests

Vehicle Description	Vehicle 1		Vehicle 2	
	2012 Passenger Car (4 Cyl., PFI, NA ³)		2010 Passenger Car (6 Cyl., PFI, NA ³)	
Altitude	Sea Level (0 ft.)	Denver (5,400 ft)	Sea Level (0 ft.)	Denver (5,400 ft)
Fuel Economy Change from 87 AKI to 85 AKI in MPG	29.04 – 27.10 = 1.94	28.65 – 27.07 = 1.58	23.22 – 22.14 = 1.08	22.85 – 22.36 = 0.49
Fuel Economy Change (%)	7.2 %	5.8 %	4.9 %	2.2 %

Notes: 1. Pump Octane = (RON + MON)/2
 2. The US06 Standard Vehicle Emissions test requires a driver to follow a specified vehicle speed pattern so vehicles tested in many different emissions labs can be compared. Test can generate a Fuel Economy number from the Emissions data.
 3. Vehicle Information: Cyl = Cylinder, PFI = Port Fuel Injected, NA = Naturally Aspirated (Common in today's marketplace.)

Vehicle 1: A Closer Look at 85 and 87 Pump Octane Effects on Engine Fueling, Vehicle Load Factor, and Catalyst Temperature

US06 Comparison at Sea Level

Vehicle 1				
Test Identification No.	5A	3A	Change Relative to 85 AKI	Benefit of 87 AKI
Altitude	Sea Level	Sea Level	---	
Octane	85 AKI	87 AKI	---	
Lambda	0.9748	0.9836	0.90%	Leaner Fuel Amount
Load %	30.19	29.79	-1.32%	Lighter Engine Load
Throttle %	17.51	17.00	-2.91%	Better Fuel Use
Pre-Cat Temp. (Deg C)	729.59	727.31	-2.28	Lower Catalyst Temp.

US06 Comparison at Altitude

Vehicle 1				
Test Identification No.	6A	4A	Change Relative to 85 AKI	Benefit of 87 AKI
Altitude	Denver	Denver	---	
Octane	85 AKI	87 AKI	---	
Lambda	0.9786	0.9849	0.64%	Leaner Fuel Amount
Load %	29.43	27.93	-5.10%	Lighter Engine Load
Throttle %	21.32	19.63	-7.93%	Better Fuel Use
Pre-Cat Temp (deg. C)	728.5	713.5	-15.0	Lower Catalyst Temp.

Low Octane Causes Inefficient Vehicle Operation

Vehicle Performance Benefits of 87 Pump Octane ¹ Relative to 85 Octane in Standardized US06 ² Emissions Tests				
	Vehicle 1		Vehicle 2	
Vehicle Description	2012 Passenger Car (4 Cyl., PFI, NA ³)		2010 Passenger Car (6 Cyl., PFI, NA ³)	
Altitude	Sea Level (0 ft.)	Denver (5,400 ft)	Sea Level (0 ft.)	Denver (5,400 ft)
Fuel Economy Change from 87 AKI to 85 AKI in MPG	29.04 – 27.10 = 1.94	28.65 – 27.07 = 1.58	23.22 – 22.14 = 1.08	22.85 – 22.36 = 0.49
Fuel Economy Change (%)	7.2 %	5.8 %	4.9 %	2.2 %

Notes: 1. Pump Octane = (RON + MON)/2
 2. The US06 Standard Vehicle Emissions test requires a driver to follow a specified vehicle speed pattern so vehicles tested in many different emissions labs can be compared. Test can generate a Fuel Economy number from the Emissions data.
 3. Vehicle Information: Cyl = Cylinder, PFI = Port Fuel Injected, NA = Naturally Aspirated (Common in today's marketplace.)

Vehicle 1: A Closer Look at 85 and 87 Pump Octane Effects on Engine Fueling, Vehicle Load Factor, and Catalyst Temperature

US06 Comparison at Sea Level

Vehicle 1				
Test Identification No.	5A	3A	Change Relative to 85 AKI	Benefit of 87 AKI
Altitude	Sea Level	Sea Level	---	
Octane	85 AKI	87 AKI	---	
Lambda	0.9748	0.9836	0.90%	Leaner Fuel Amount
Load %	30.19	29.79	-1.32%	Lighter Engine Load
Throttle %	17.51	17.00	-2.91%	Better Fuel Use
Pre-Cat Temp. (Deg C)	729.59	727.31	-2.28	Lower Catalyst Temp.

US06 Comparison at Altitude

Vehicle 1				
Test Identification No.	6A	4A	Change Relative to 85 AKI	Benefit of 87 AKI
Altitude	Denver	Denver	---	
Octane	85 AKI	87 AKI	---	
Lambda	0.9786	0.9849	0.64%	Leaner Fuel Amount
Load %	29.43	27.93	-5.10%	Lighter Engine Load
Throttle %	21.32	19.63	-7.93%	Better Fuel Use
Pre-Cat Temp (deg. C)	728.5	713.5	-15.0	Lower Catalyst Temp.

ASTM D02 Subcommittee A: Gasoline Octane Work Group Plan

- Follow-up to Dec. 2012 ASTM Workgroup Meeting
 - Evaluate Vehicle Octane Rating Technique developed by Sasol Oil (S. Africa)
 - Define test program to study octane effects on vehicle performance at altitude
 - Modeled after initial two vehicle scoping tests?
 - GM High Altitude Emissions Chamber Program – Minimize test variation
 - Metrics – FE, Emissions, Load %, Enrichment, Pre-cat Inlet Temperature
 - 4 to 6 instrumented vehicles – PFI vs GDI, N.A. vs Boosted
 - Matched E10 fuel pair – equivalent heating value, composition, H/C ratio, etc...
 - Test Cycles – A-B-A Format (85 – 87 – 85) LA92 and US06 Emissions Cycles
 - Reduce variation: One Test driver; Evaluate Engine RPM traces for each cycle
 - Timing: by mid-April

NCWM Item 237-2 Ballot

- New business item presented to each of the 4 regions – Fall, 2012
- Form 15 author wishes to see this item move forward as a voting item to the 2013 Annual Mtg
 - Form 15 HB 130 language shown on next slide

Handbook 130 – Proposed Gasoline Octane Content

2.1. Gasoline and Gasoline-Oxygenate Blends.

2.1.4. Minimum Antiknock Index (AKI). – The AKI of gasoline and gasoline-oxygenate blends shall not be less than 87. The AKI shall not be less than the AKI posted on the product dispenser or as certified on the invoice, bill of lading, shipping paper, or other documentation;

2.1.5. Minimum Motor Octane Number. – The minimum motor octane number shall not be less than 82. ~~for gasoline with an AKI of 87 or greater;~~

3.2. Automotive Gasoline and Automotive Gasoline-Oxygenate Blends.

3.2.5. Prohibition of Terms. – It is prohibited to use specific terms to describe a grade of gasoline or gasoline-oxygenate blend unless it meets the minimum antiknock index requirement shown in Table 1. Minimum Antiknock Index Requirements.

Table 1. Minimum Antiknock Index Requirements

Term	Minimum Antiknock Index	
	ASTM-D4814 Altitude Reduction Areas IV and V	All Other ASTM-D4814 Areas
Premium, Super, Supreme, High Test	90	91
Midgrade, Plus	87	89
Regular-Leaded	86	88
Regular, Unleaded	85	87
Economy	--	86

Appendix F

Handbook 133 – Checking the Net Contents of Packaged Goods

Items:

Item 260-4: 4.3. Paper Plates and Sanitary Paper Products

Table of Contents	
Items	L&R Appendix F – Page
Georgia Pacific.....	3
Foodservice Packing Institute, October 7, 2012.....	10
Richard Davis, Response to Plate Dimension Tester, January 22, 2013.....	12
Georgia Pacific, Paper Plate Tester Drawings	14

THIS PAGE INTENTIONALLY LEFT BLANK

Handbook 133: Section 4.5. Paper Plates and Sanitary Paper Products

Georgia Pacific

Contents:

- Standard Test Method using a Plate Dimension Tester
- Pictures of a Plate Dimension Tester
- Reproducibility Data
- Blueprint of a Plate Dimension Tester

STANDARD TEST METHOD

Title: Diameter of Plates and Bowls

PPR:

Original: New

Authorized by:

Effective: September 1, 2010

1 Purpose/Scope

- 1.1 This method is for determining the diameter of plates and bowls utilizing the National Institute of Standards and Technology (NIST) Handbook 133 Section 4.5 (Fourth Edition) and/or Section 5.5 (Third Edition) method.

2 Apparatus/Materials

- 2.1 Plate Diameter Gauge, accurate to 1/50th (0.02) of an inch available from:
Research Dimensions
1720 Oakridge Road
Neenah, WI 54956
920-722-2289
- 2.2 Acrylic weights (4, 6 and 8-inch diameter), weighing each 225 +/- 10 grams available from Research Dimensions (2.1).
- 2.3 Magnifying glass
- 2.4 6-inch calibration gauge block available from:
McMaster-Carr
Part no. 19575A299
www.mcmaster.com
630-833-0300
- 2.5 9/64-inch Allen wrench

3 Training/Safety

- 3.1 The Primary Person Responsible (PPR) trains operators for this method.

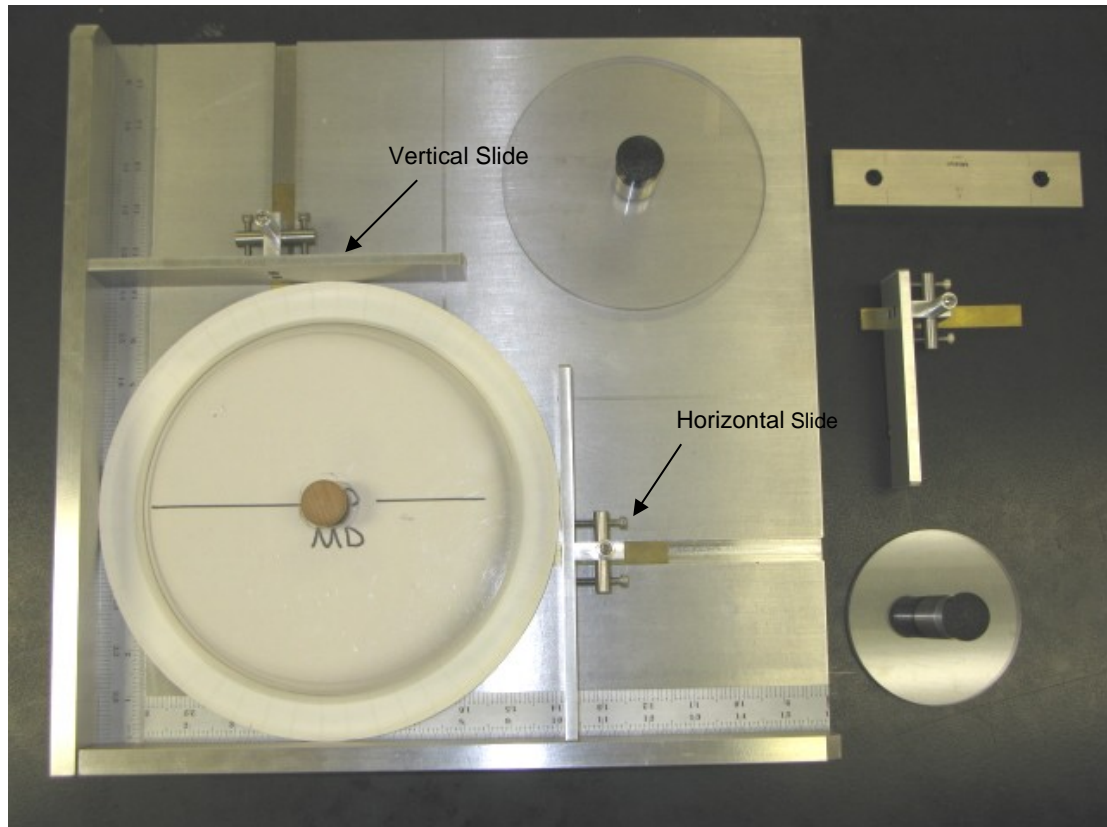

Figure 1: Plate diameter gauge.

4 Specimen Preparation

- 4.1 Obtain samples, precondition and condition according to TAPPI procedures.

5 Maintenance/Calibration

- 5.1 The PPR maintains the apparatus for this method.
- 5.2 Perform a calibration check before the instrument is used.
 - 5.2.1 Place the 6-inch gauge block over the vertical slot with one end against the stationary horizontal edge of the fixture. Move the vertical slide against the gauge block and read the measurement (Figure 2). The measurement should be 6.00 inches. If you encounter any problems contact the PPR for calibration.

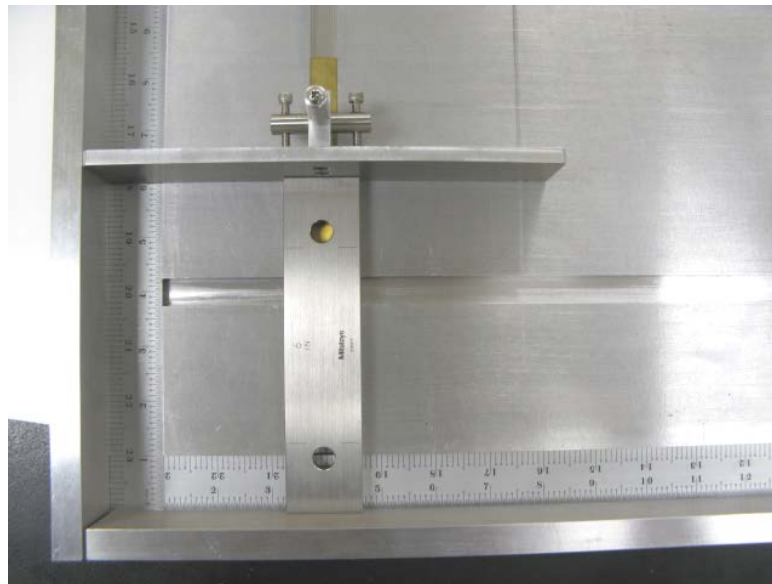

Figure 2: Vertical slide calibration check

- 5.2.2 Place the 6-inch gauge block over the horizontal slot with one end against the stationary vertical edge of the fixture. Move the large horizontal slide against the gauge block and read the measurement (Figure 3). The measurement should be 6.00 inches. If you encounter any problems contact the PPR for calibration.

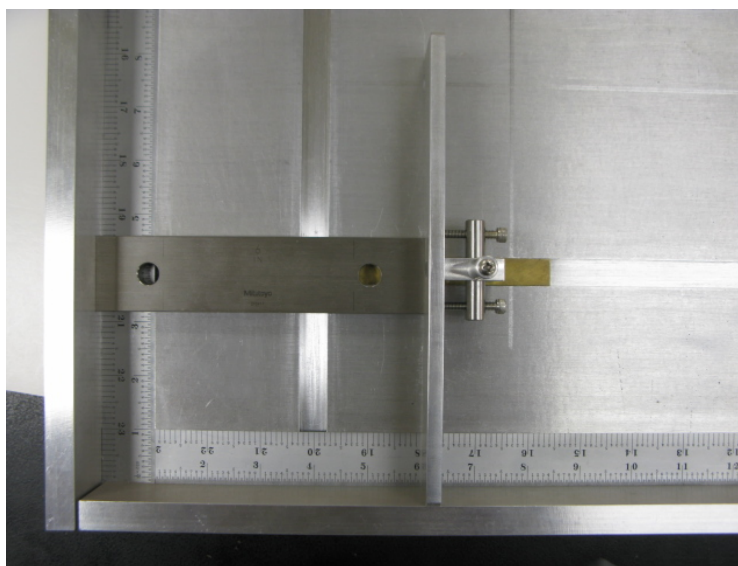

Figure 3: Large horizontal slide calibration check

- 5.2.3 Remove the large horizontal slide from the tester and place the small horizontal slide on the tester. Move it against the gauge block and read the measurement (Figure 4). The measurement should be 6.00 inches. If you encounter any problems contact the PPR for calibration.

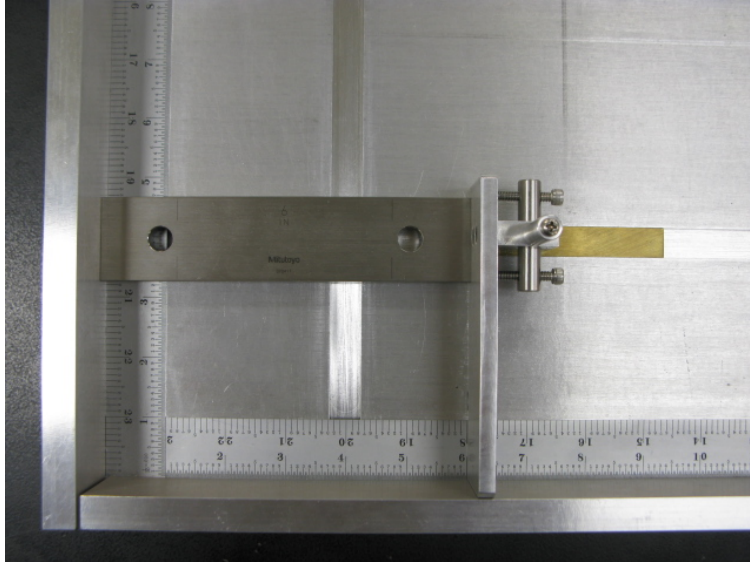

Figure 4: Small horizontal slide calibration check

6 Procedure

- 6.1 Mark the MD direction of the plate or bowl.
- 6.2 Place the plate or bowl to be measured on the measuring base plate, eating surface down, so that two sides of the plate or bowl touch both the stationary horizontal and vertical edge of the diameter gauge. The MD direction of the plate should be in the horizontal position (Figure 1).
- 6.3 Place the appropriate size Acrylic weight on top of the plate or bowl. The Acrylic weight should cover the entire base of the plate or bowl but not large enough to interfere with the diameter measurement.
- 6.4 Gently move the vertical and horizontal slides against the edge of the plate or bowl. Slide contact should be light so the sample is not deformed by the contact.
- 6.5 If the plate or bowl is smaller than 8 inches in diameter, replace the moving large horizontal guide with the small horizontal guide. If the plate or bowl is *circular*, record the *smallest diameter measurement*.
- 6.6 If the plate is oblong, use the Acrylic weight that is closest to the smaller dimension that does not interfere with its measurement. Record the plate diameter in both dimensions.
- 6.7 A magnifying glass can be used to aid in reading the measurements.

7 Report

- 7.1 For circular plates and bowls record the minimum diameter measurement to the nearest 0.02-inch.
- 7.2 For oblong plates record both the small and large dimension to the nearest 0.02-inch.
- 7.3 Clearly state any deviations from the standard procedure, and note any unusual features or characteristics of the sample.

8 References/Additional Information

- 8.1 U.S. Department of Commerce - National Institute of Standards and Technology - NIST Handbook 133, Fourth Edition Section 4.5 and/or Third Edition section 5.5.

Plate Dimension Tester Photos

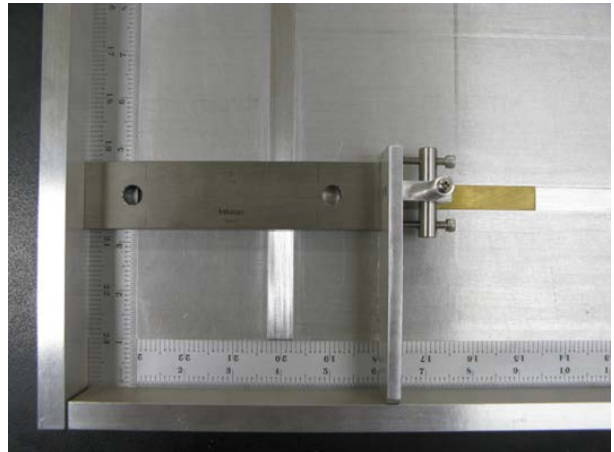
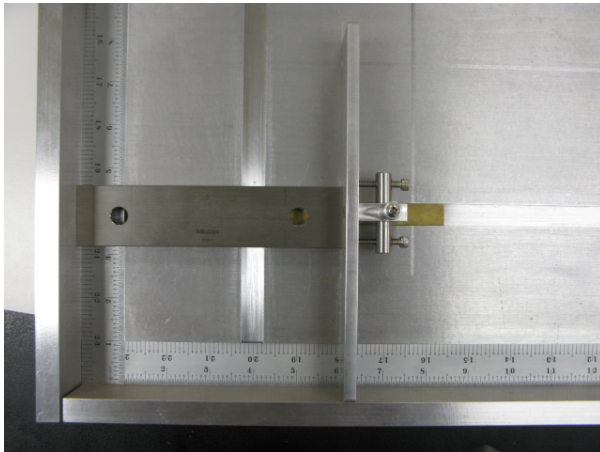
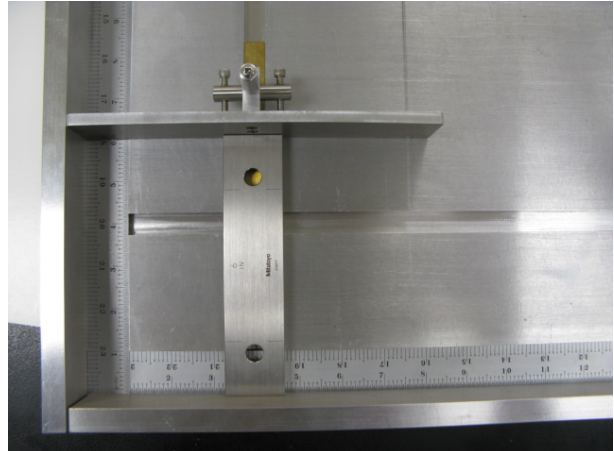
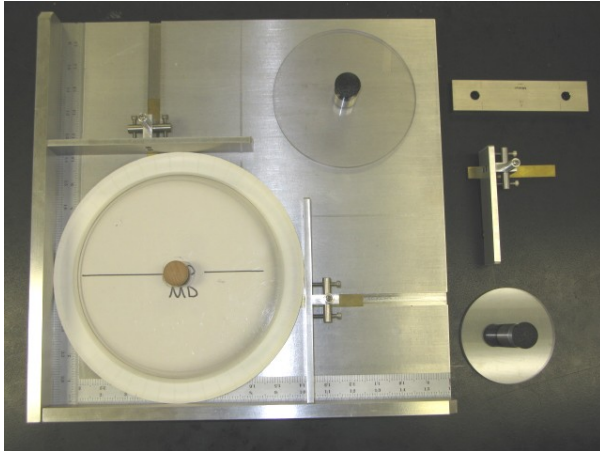

Reproducibility Data

Descriptive Statistics Plate Dimension Tester

Based on the 60 data points available (10 plates, 3 operators, 2 repeats), the variation observed in the measurements is reflective of the resolution in the gage. The minimum gradient in the gage is 1/50th of an inch (0.02 in), and the confident interval for both the 9 and 10 inch plates is well within this tolerance.

Variable	Descriptive Statistics (Gauge RnR – NBS Plate Dia 1)						
	Valid N	Minimum	Maximum	Mean	Std. Dev.	Confidence -95.000%	Confidence +95.000%
9-inch Plate Diameter	60	8.66	8.70	8.673	0.0109	8.670	8.676
10-inch Plate Diameter	60	10.12	10.18	10.143	0.0089	10.141	10.145

For the 9 inch plate, the expected average is 8.673 +/- 0.003 inches.

For the 10 inch plate, the expected average is 10.143 +/- 0.002 inches.



October 7, 2012

To whom it may concern:

The Foodservice Packaging Institute (FPI) is the trade association for the foodservice packaging industry in North America and represents approximately 85 percent of the companies that manufacture foodservice packaging products made from paper, plastic and aluminum.

One of FPI's roles is to facilitate discussions around industry guidelines and best practices. This is of benefit to the industry and to our broader value chain partners.

FPI's Technical Committee is comprised of representatives from a number of FPI member companies. Since 2010, they have discussed the need for an improved testing method for measuring the dimensions of plates, platters and bowls.

FPI's Technical Committee has reviewed the specifications for the proposed testing device and supports the use of this device. We believe it provides more precise, accurate and repeatable results than the method described in NIST Handbook 133, section 4.5 and currently being used by the National Conference on Weights and Measures (NCWM).

Sincerely,

A handwritten signature in black ink, appearing to read "Lynn M. Dyer", written in a cursive style.

Lynn M. Dyer
President

October 15th, 2012 questions – Response on 1-22-2013 by Richard Davis

Questions regarding the Plate Dimension Tester, submitted by David Sefcik, following the Southern W&M meeting.

Below are some thoughts and considerations regarding the proposal. We support your efforts and for bringing this modern equipment and specification improvements to our current test methods.

Let me know if it would be possible to borrow or bring one of the devices to try out and demonstrate at the Interim?

- The statement in the video to “take the shorter of the two measurements” may raise some questions. When dimensional testing is done on other products, and variations are found, inspectors are taught to take several readings and then the average. Also with dimensional testing, inspectors are taught to take a minimum 3 measurements, then average. This allows for reasonable variations (e.g., in addition, in 4.5 c, Step 2, it states that if the dimensions vary, that at least 10 items from each package should be measured. Measure and average the dimension.)
 - The point is well taken. We use the shorter of the two dimensional readings as a very conservative measurement. However, we have considered your comment and have altered the test method such that the plate dimension will be recorded as the average of the two 90 degree measurements. As to the number of items to be tested, we leave that to the circumstances of the testing purpose as described in an appropriate sampling and testing scenario. When testing on the production line, 1 sample may be enough to verify the process is lined out, but sampling a lot, delivery, or shipment may be quite a different case. The test method shows how to conduct the test, the sampling procedure should address the sample size required – so we did not specify it.
- For weights and measures enforcement, the (stationary) rulers will have to be certified by a state metrology laboratory, so they should be removable for certification, re-certification, or replacement. Is there also a metric ruler? Making them removable will enable metric (SI) measures to be used.
 - Based on the placement of the rulers in an indented groove of the tester, they should not have stress on them to require re-certification; however, they are removable so they could be recertified if desired. The calibration block is also certified and intended to be used to verify no change in the rulers. It can be recertified as needed as well.
- The 6 inch block in the video provides a means to only verify 1 graduation on the ruler. Are there plans to have different blocks available suitable to different size plates (i.e., 10 inch)? Regardless, weights and measures will verify all of the graduations before use, but it wouldn't hurt reliability if you were testing for example, 10 inch plates, to be able to do a quick verification of the graduation at that point too.
 - Our feeling is - if the rulers are certified and can be recertified if necessary, and the block is also certified, then if you can validate any one point on the certified ruler as being accurate, the whole ruler should be accurate. You therefore would not need two certification blocks.

- The current test procedure in the Note in 4.5 a, states: “do not distort the item’s shape during measurement”. Placing a weighted disk on the plate may be viewed as a distortion. You may want to elaborate on how the determination of the proper weight of the disks was arrived. The specifications for the discs are important because pressing down on the plates can distort the product as some plates are pretty flimsy, so there needs to be some guidance on how much weight the industry wants for different plates. The plate in the video appeared to be fairly rigid but others in the marketplace are not so sturdy.
 - We conducted a series of testing scenarios to test whether or not a single weight of disk was appropriate. We used a variety of products (paper, foam, and molded pulp) to show that the one weight was sufficient for testing a wide range of products. We have submitted data to show our findings. We remain confident that the 225 gram weights are sufficient to be used across the broad range of products.

- You may want to describe more about how the increased usability of this device can be used to accommodate a greater number of products such as napkins, paper towels, plastic plates, sandwich bags, etc... so that its cost can be better justified. For paper towels you may want to include a piece a Plexiglas that can be used to flatten and help take out creases of flat paper products (napkins).
 - We have not addressed the use of this device for anything other than disposable plates, bowls, and platters. It may be possible to adapt it for other products but we have not taken the time and resources to do that. Potentially a good idea, but one that hasn’t been explored at this time.

- You will likely be asked and need to include the specifications to build the device as part of HB133 test procedure. States may choose to build the device themselves or have another 3rd party do it. It needs to be available for all and not a reliance on one manufacturer. This is generally accomplished by providing the specifications right in the Handbook.
 - The engineering drawings were included in the original submission to the Southern Conference. Based on some of the feedback we received from you and others, we made a couple minor changes so the new drawings will also be available to the Conference if anyone chooses to build their own devise.

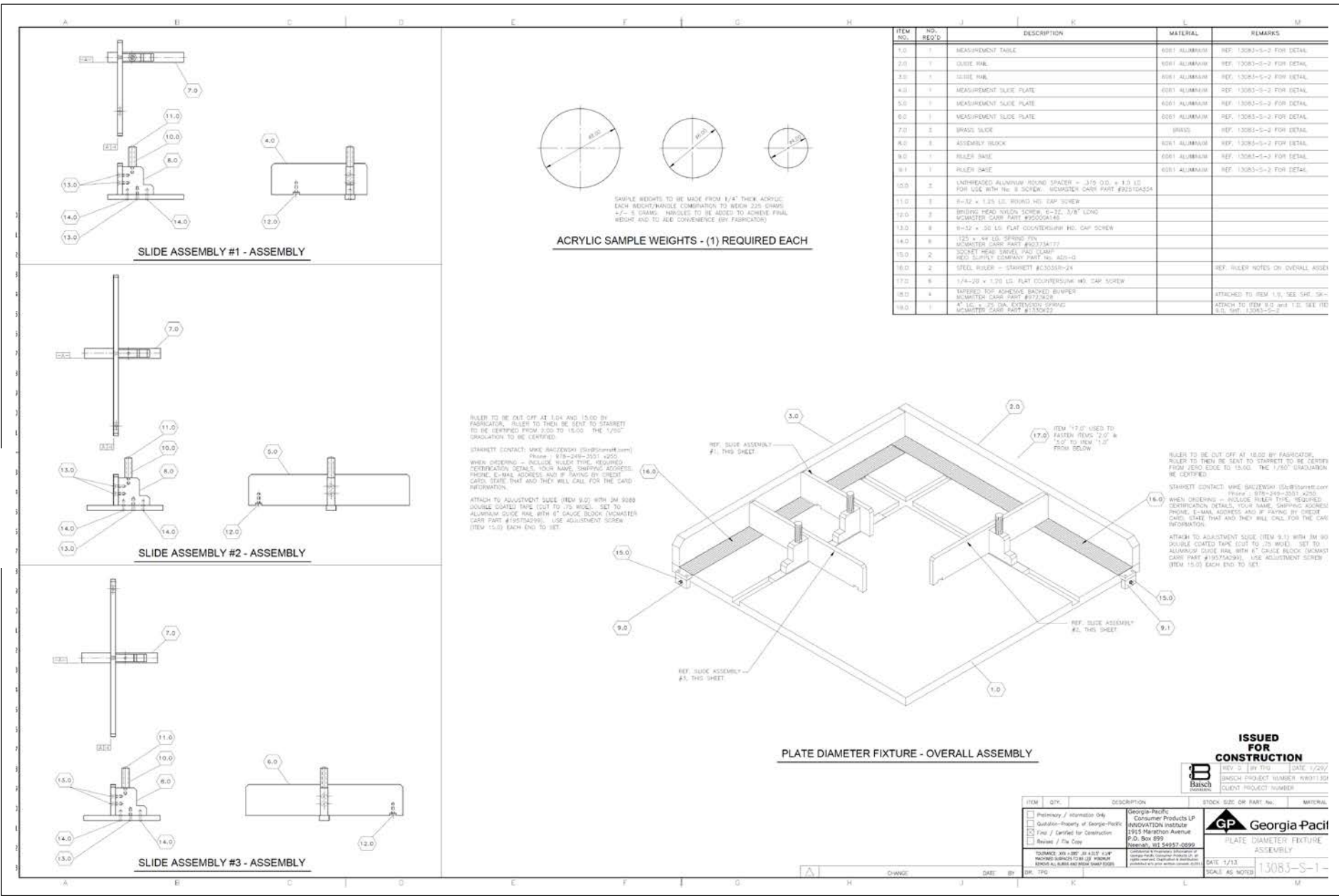

ITEM NO.	NO. REQ'D	DESCRIPTION	MATERIAL	REMARKS
1.0	1	MEASUREMENT TABLE	6061 ALUMINUM	REF. 13083-S-2 FOR DETAIL
2.0	1	SLIDE RAIL	6061 ALUMINUM	REF. 13083-S-2 FOR DETAIL
3.0	1	SLIDE RAIL	6061 ALUMINUM	REF. 13083-S-2 FOR DETAIL
4.0	1	MEASUREMENT SLIDE PLATE	6061 ALUMINUM	REF. 13083-S-2 FOR DETAIL
5.0	1	MEASUREMENT SLIDE PLATE	6061 ALUMINUM	REF. 13083-S-2 FOR DETAIL
6.0	1	MEASUREMENT SLIDE PLATE	6061 ALUMINUM	REF. 13083-S-2 FOR DETAIL
7.0	2	BRASS SLIDE	BRASS	REF. 13083-S-2 FOR DETAIL
8.0	2	ASSEMBLY BLOCK	6061 ALUMINUM	REF. 13083-S-2 FOR DETAIL
9.0	1	RULER BASE	6061 ALUMINUM	REF. 13083-S-2 FOR DETAIL
9.1	1	RULER BASE	6061 ALUMINUM	REF. 13083-S-2 FOR DETAIL
10.0	2	UNF-HEADED ALUMINUM ROUND SPACER - .375 O.D. x 1.0 LG. FOR USE WITH NO. 8 SCREW. WDMASTER CARR PART #9221GAS54		
11.0	2	3/8-32 x 1.25 LG. ROUND HD. CAP SCREW		
12.0	2	BRIDGING HEAD W/LOCK SCREW, 6-32, 3/8" LONG		
13.0	2	SOCKET HEAD SCREW PART #95503418		
14.0	2	1/2" x 1/4" LG. SPRING PIN		
15.0	2	SOCKET HEAD SCREW PART #95503417		
16.0	2	SOCKET HEAD SCREW PART NO. 408-G		
17.0	2	STEEL RULER - STARRETT #C33338-24		REF. RULER NOTES ON OVERALL ASSEMBLY
17.1	2	1/4"-20 x 1.25 LG. FLAT COUNTERSUNK HD. CAP SCREW		
18.0	4	TAPERED TOP ADHESIVE BACKED BUMPER		ATTACHED TO ITEM 1.0, SEE SHE. SK-1
18.0	1	1" LG. x .75 DIA. EXTENSION SPRING		ATTACH TO ITEM 9.0 AND 9.1. SEE TD 1.0, SHE. 13083-S-2

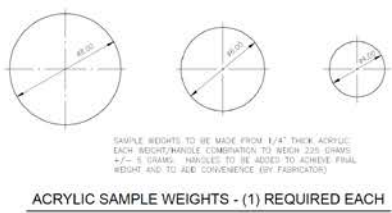

RULER TO BE CUT OFF AT 18.04 AND 15.00 BY FABRICATOR. RULER TO THEN BE SENT TO STARRETT TO BE CERTIFIED FROM 2.00 TO 15.00. THE 1/32" DISCREPANCY TO BE CERTIFIED.

STARRETT CONTACT: MIKE SAGEZDOR (MS@stret.com) Phone: 878-249-2501, 4255 WHEN ORDERING - INCLUDE RULER TYPE, REQUIRED CERTIFICATION, SERIAL, YOUR NAME, SHIPPING ADDRESS, PHONE, E-MAIL ADDRESS AND IF PAYING BY CREDIT CARD, STATE THAT AND THEY WILL CALL FOR THE CARD INFORMATION.

ATTACH TO ADJUSTMENT SLIDE (ITEM 9.0) WITH 3M 9288 DOUBLE COATED TAPE (CUT TO .75 WIDE). SET TO ALUMINUM SLIDE RAIL WITH #1 GAUGE BLOCK (WDMASTER CARR PART #1957A295). USE ADJUSTMENT SCREW (ITEM 15.0) EACH END TO SET.

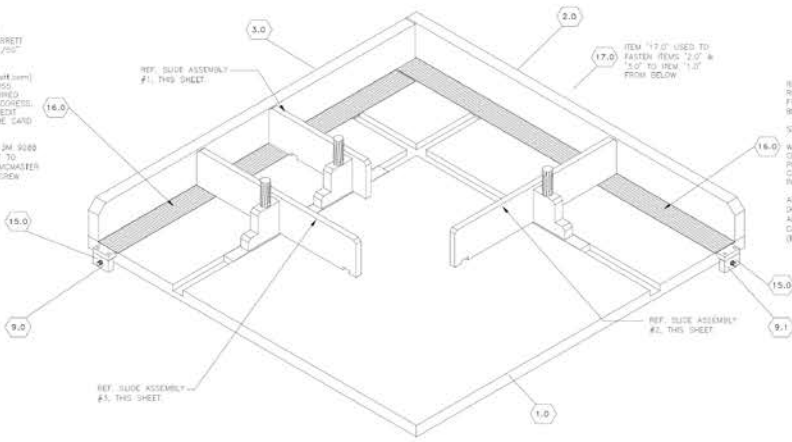

RULER TO BE CUT OFF AT 18.00 BY FABRICATOR. RULER TO THEN BE SENT TO STARRETT TO BE CERTIFIED FROM ZERO EDGE TO 18.00. THE 1/32" DISCREPANCY TO BE CERTIFIED.

STARRETT CONTACT: MIKE SAGEZDOR (MS@stret.com) Phone: 878-249-2501, 4255 WHEN ORDERING - INCLUDE RULER TYPE, REQUIRED CERTIFICATION, SERIAL, YOUR NAME, SHIPPING ADDRESS, PHONE, E-MAIL ADDRESS AND IF PAYING BY CREDIT CARD, STATE THAT AND THEY WILL CALL FOR THE CARD INFORMATION.

ATTACH TO ADJUSTMENT SLIDE (ITEM 9.1) WITH 3M 9288 DOUBLE COATED TAPE (CUT TO .75 WIDE). SET TO ALUMINUM SLIDE RAIL WITH #1 GAUGE BLOCK (WDMASTER CARR PART #1957A295). USE ADJUSTMENT SCREW (ITEM 15.0) EACH END TO SET.

PLATE DIAMETER FIXTURE - OVERALL ASSEMBLY

ISSUED FOR CONSTRUCTION
 REV. 2 | 18 FEB 2013 | DATE 1/22/13
 BALSCH PROJECT NUMBER 16801354
 CLIENT PROJECT NUMBER

ITEM	QTY	DESCRIPTION	STOCK SIZE OR PART NO.	MATERIAL
<input type="checkbox"/>		Primary / Alternative Only		
<input type="checkbox"/>		Quotation-Property of Georgia-Pacific		
<input type="checkbox"/>		Used / Certified for Construction		
<input type="checkbox"/>		Revised / The Copy		
QUANTITY SHOWN IS A SUGGESTION		Georgia-Pacific Consumer Products LP INNOVATION INSTITUTE 1915 Marathon Avenue P.O. Box 899 Marietta, GA 30067-0899	GeorgiaPac PLATE DIAMETER FIXTURE ASSEMBLY DATE 1/13 SCALE AS NOTED 13083-S-1-	

L&R - F14

Appendix G

Handbook 130 – Uniform Engine Fuels and Automotive Lubricants Regulation

Items:

Item 237-8: 4.3 Dispenser Filters

Table of Contents	
Items	L&R Appendix G – Page
CIM TEK Filtration, July 10, 2013.....	3

THIS PAGE INTENTIONALLY LEFT BLANK



A Registered ISO 9001: 2008 Company

GET MORE OUT OF YOUR FUEL™

Judy Cardin
Chairwoman, Laws and Regulation Committee
National Conference on Weights and Measures
Wisconsin Weights and Measures
2811 Agriculture Drive
Madison, Wisconsin 53708

Date: 7/10/13
Re: Fuel Filtration

Ms. Cardin,

I am writing in response to a question I have been asked regarding filtration for diesel fuel at the dispenser and item 247-8 Section 4.3 Dispenser Filters on the NCWM Laws and Regulations Committee agenda. For years, the standard rule of thumb has been “30 Micron” filters for diesel applications and “10 Micron” filters for gasoline applications. Please refer to Filter Manufacturers Council Technical Service Bulletin TSB 89-5, “The Micron Rating for Media in Fluid Filters” (<http://www.aftermarketsuppliers.org/Councils/Filter-Manufacturers-Council/TSBs-2/English/89-5R3.pdf>) for an explanation of micron ratings for fluid filters.

Based on our experience, most diesel dispensers are outfitted with “30 Micron” filters and perform adequately. This statement applies to both high and low flow applications. There are a variety of factors that go into filter selection for a given application to ensure that proper performance is achieved in a cost effective manner. I would be more than happy to elaborate on this however it is a complicated subject that would require several pages to communicate appropriately via letter.

Please let us know if you have any questions and we will be more than happy to help.

Regards,

A handwritten signature in black ink, appearing to read "Jeff Ayers".

Jeff Ayers
V.P. Engineering
Cim-Tek Filtration
217-6782511 x. 334
jeff@cim-tek.com

THIS PAGE INTENTIONALLY LEFT BLANK

Report of the Specifications and Tolerances (S&T) Committee

Mr. Kenneth Ramsburg, Committee Chair
Maryland Weights and Measures

300 INTRODUCTION

This is the final report of the Committee on Specifications and Tolerances (S&T) (hereinafter referred to as the “Committee”) for the 98th Annual Meeting of the National Conference on Weights and Measures (NCWM). The report is based on the Interim Report offered in the NCWM Publication 16, “Committee Reports,” testimony at public hearings, comments received from the regional weights and measures associations and other parties, the NCWM 2013 Online Position Forum, the addendum sheets issued at the Annual Meeting, and actions taken by the membership at the voting session of the Annual Meeting.

Table A identifies the agenda and appendix items. The agenda items are identified in the report by Reference Key Number, Item Title, and Page Number. The item numbers are those assigned in the Interim Meeting agenda. Voting items are indicated with a “V,” or if the item was part of the Voting Consent calendar by the suffix “VC” after the item number. Items marked with an “T” after the Reference Key Numbers are Information items. Items marked with a “D” after the Key Numbers are Developing items. The Developing designation indicates that an item, while it has merit, may not be adequately developed for action at the national level. Items marked “W” have been withdrawn from consideration. Items marked with a “W” will generally be referred to the regional weights and measures associations because they either need additional development, analysis, and input or did not have sufficient Committee support to bring them before the NCWM. Table B identifies the acronyms for organizations and technical terms used throughout the report, and Table C provides a summary of the results of the voting on the Committee’s items and the report in its entirety.

This report contains recommendations to amend the National Institute of Standards and Technology (NIST) Handbook 44, 2013 Edition, “Specifications, Tolerances, and Other Technical Requirements for Weighing and Measuring Devices.” Suggested revisions are shown in **bold face print** by ~~striking out~~ information to be deleted and underlining information to be added. New items proposed for the handbook are designated as such by underscored bold face print, and nonretroactive items are indicated in *italics*.

Note: The policy of NIST is to use metric units of measurement in all of its publications; however, recommendations received by the NCWM technical committees have been printed in this publication as submitted. Therefore, the report may contain references to inch-pound units.

Subject Series List

Introduction	300 Series
NIST Handbook 44 – General Code.....	310 Series
Scales.....	320 Series
Belt-Conveyor Scale Systems	321 Series
Automatic Bulk Weighing Systems	322 Series
Weights.....	323 Series
Automatic Weighing Systems	324 Series
Liquid-Measuring Devices	330 Series
Vehicle-Tank Meters	331 Series
Liquefied Petroleum Gas and Anhydrous Ammonia Liquid-Measuring Devices	332 Series
Hydrocarbon Gas Vapor-Measuring Devices.....	333 Series
Cryogenic Liquid-Measuring Devices.....	334 Series

Milk Meters	335 Series
Water Meters	336 Series
Mass Flow Meters	337 Series
Carbon Dioxide Liquid-Measuring Devices.....	338 Series
Hydrogen Gas-Metering Devices – Tentative Code.....	339 Series
Vehicle Tanks Used as Measures	340 Series
Liquid Measures	341 Series
Farm Milk Tanks	342 Series
Measure-Containers.....	343 Series
Graduates.....	344 Series
Dry Measures	345 Series
Berry Baskets and Boxes.....	346 Series
Fabric-Measuring Devices.....	350 Series
Wire-and Cordage-Measuring Devices	351 Series
Linear Measures	352 Series
Odometers	353 Series
Taximeters.....	354 Series
Timing Devices	355 Series
Grain Moisture Meters	356 Series
Near-Infrared Grain Analyzers.....	357 Series
Multiple Dimension Measuring Devices.....	358 Series
Electronic Livestock, Meat, and Poultry Evaluation Systems and/or Devices.....	359 Series
Other Items – Developing Items.....	360 Series

Table A
Table of Contents

Reference Key	Title of Item	S&T Page
320	SCALES	6
320-1	VC S.6.4. Railway Track Scales and Appendix D – Definitions	6
320-2	W Table 4 – Minimum Test Weights and Test Loads.....	11
320-3	W T.N.3., Table 6. Maintenance Tolerances.....	13
320-4	VC Appendix C – Units of Mass (ton).....	16
320-5	I Part 2.20. Weigh-In-Motion Vehicle Scales for Law Enforcement – Work Group.....	21
321	BELT-CONVEYOR SCALE SYSTEMS	26
321-1	VC UR.1.2. Conveyor Installation.....	26
321-2	VC Appendix D – Definitions: Belt Revolution, Belt Load, Integrator, Loading Point, and Master Weight Totalizer	28
330	LIQUID MEASURING DEVICES	30
330-1	W S.1.6.4.2 (a) Product Identity and UR.3.2. Unit Price and Product Identity	30
330-2	VC Table T.2. Accuracy Classes and Tolerances for Liquid Measuring Devices	32
330-3	I N.4.2.4. Wholesale Devices.....	34
330-4	I UR.3.3. Computing Device.....	40
331	VEHICLE-TANK METERS	43
331-1	VC Table 1. Accuracy Classes and Tolerances for Vehicle-Tank Meters	43
331-2	VC T.4. Product Depletion Test.....	45
336	WATER METERS	48
336-1	V UR.3. Installation Requirements.....	48
337	MASS FLOW METERS	49

337-1	I	Appendix D – Definitions: Diesel Liter and Diesel Gallon Equivalents (DLE, DGE)	49
337-2	I	S.1.2. Compressed Natural Gas Dispensers, S.1.3.1.1. Compressed Natural Gas Used as an Engine Fuel, S.5.2. Marking of Gasoline Volume Equivalent Conversion Factor	55
337-3	VC	Table T.2. Accuracy Classes and Tolerances for Mass Flow Meters	57
354		TAXIMETERS	59
354-1	D	Global Positioning Systems for Taximeters	59
356		GRAIN MOISTURE METERS	60
356-1	VC	Table S.2.5. Categories of Device and Methods of Sealing.....	60
356-2	VC	UR.3.4. Printed Tickets	63
356-3	D	Appendix D – Definitions: Remote Configuration Capability	64
360		OTHER ITEMS – DEVELOPING ITEMS.....	64
360-1	D	International Organization of Legal Metrology (OIML) Report	64
360-2	D	G-S.1. Identification. – (Software)	66
360-3	D	Part 3.30. Price Posting and Computing Capability and Requirements for a Retail Motor-Fuel Dispenser (RMFD)	72
360-4	I	Part 2.20. Weigh-In-Motion Vehicle Scales for Law Enforcement – Work Group.....	74
360-5	D	USNWG on Taximeters – Taximeter Code Revisions and Global Positioning System-Based Systems for Time and Distance Measurement.....	74
360-6	D	Global Positioning Systems for Taximeters	77
360-7	D	Appendix D – Definitions: Remote Configuration Capability	77

Appendices

A —	Items 337-1 and 337-2:	Handbook 44, Background and Justification for Handbook 44 Definition of “Diesel Gallon Equivalent (DGE)” of Natural Gas as a Vehicular Fuel	A1
B —	Item 360-4:	Handbook 44, Draft Tentative Code Applicable to Weigh-In-Motion Systems Used for Vehicle Enforcement Screening and proposed definitions to be added to NIST Handbook 44, Appendix D to support the Weigh-In-Motion Systems used for Vehicle Enforcement Screening – Draft Code	B1

Table B
Glossary of Acronyms and Terms

Acronym	Term	Acronym	Term
AAR	Association of American Railroad	LMD	Liquid Measuring Devices
AES	Advanced Encryption Standard	LNG	Liquefied Natural Gas
API	American Petroleum Institute	MMA	Meter Manufacturers Association
AREMA	American Railway Engineering and Maintenance-of-Way Association	MPMS	Manual of Petroleum Measurement Standards
AWWA	American Water Works Association	NCWM	National Conference on Weights and Measures
BCS	Belt-Conveyor Scale	NEWMA	Northeastern Weights and Measures Association
CC	Certificate of Conformance	NIST	National Institute of Standards and Technology
CNG	Compressed Natural Gas	NTEP	National Type Evaluation Program
CWMA	Central Weights and Measures Association	OIML	International Organization of Legal Metrology
DGE	Diesel Gallon Equivalent	OWM	Office of Weights and Measures
DLE	Diesel Liter Equivalent	PUC	Public Utilities Commission
DOT	Department of Transportation	RMFD	Retail Motor Fuel Dispenser
FALS	Fuels and Lubricants Subcommittee	S&T	Specifications and Tolerances
FHWA	Federal Highway Administration	SD	Secure Digital
GGE	Gasoline Gallon Equivalent	SI	International System of Units
GIPSA	Grain Inspection Packers and Stockyard Administration	SMA	Scale Manufactures Association
GLE	Gasoline Liter Equivalent	SWMA	Southern Weights and Measures Association
GMM	Grain Moisture Meter	TC	Technical Committee
GPS	Global Positioning System	USNWG	U.S. National Work Group
IATR	International Association of Transportation Regulators	WIM	Weigh-in-Motion
IEC	International Electrotechnical Commission	WWMA	Western Weights and Measures Association

Table C
Voting Results

<i>Reference Key Number</i>	<i>House of State Representatives</i>		<i>House of Delegates</i>		Results
	<i>Yeas</i>	<i>Nays</i>	<i>Yeas</i>	<i>Nays</i>	
Consent Calendar: 302-1, 302-4, 321-1, 321-2, 330-2, 331-1, 331-2, 337-3, 356-1, 356-2	34	0	35	0	Adopted
336-1	13	17	17	13	Returned to Committee
Report on its Entirety	Voice Vote				Adopted

Details of All Items
(In order by Reference Key)

320 SCALES

320-1 VC S.6.4. Railway Track Scales and Appendix D – Definitions

(This item was adopted.)

Source:

Systems Associates, Inc., (2012)

Purpose:

Align NIST Handbook 44 with the most recent version of the AAR Scale Handbook.

Item Under Consideration:

1. Amend NIST Scales Code paragraph S.6.4. Railway Track Scales. as follows:

S.6.4. Railway Track Scales. – A railway track scale shall be marked with the maximum capacity of each section of the load-receiving element of the scale. Such marking shall be accurately and conspicuously presented on, or adjacent to, the identification or nomenclature plate that is attached to the indicating element of the scale. ~~The nominal capacity of a scale with more than two sections shall not exceed twice its rated section capacity. The nominal capacity of a two section scale shall not exceed its rated section capacity.*~~ **The nominal capacity marking shall satisfy the following:**

(a) For scales manufactured from January 1, 2002, through December 31, 2013:

(1) The nominal capacity of a scale with more than two sections shall not exceed twice its rated section capacity.

(2) The nominal capacity of a two section scale shall not exceed its rated section capacity.

(b) For scales manufactured on or after January 1, 2014, the nominal scale capacity shall not exceed the lesser of:

(1) The sum of the Weigh Module Capacities as shown in Table S.6.4.M. or Table S.6.4, or;

(2) Rated Sectional Capacity (RSC) multiplied by the Number of Sections (Ns) minus the Number of Dead Spaces (Nd) minus 0.5. As a formula this is stated as $RSC \times (Ns - Nd - 0.5)$; or

(3) 290 300 kg (640 000 lb).

*[*Nonretroactive as of January 1, 2002]*

(Amended 1988, 2001, ~~and 2002,~~ **and 2013**)

<u>Table S.6.4.M.</u>	
<u>Railway Track Scale – Weigh Module Capacity</u>	
<u>Weigh Module Length (m)</u>	<u>Weigh Module Capacity (kg)</u>
<u>< 1.5</u>	<u>36 300</u>
<u>1.5 to < 3.0</u>	<u>72 600</u>
<u>3.0 to < 4.5</u>	<u>108 900</u>
<u>4.5 to < 7.0</u>	<u>145 100</u>
<u>7.0 to < 9.0</u>	<u>168 700</u>
<u>9.0 to < 10.5</u>	<u>192 300</u>
<u>10.5 to < 12.0</u>	<u>234 100</u>
<u>12.0 to < 17.0</u>	<u>257 600</u>
Note: The capacity of a particular module is based on its length and determined from corresponding capacity values specified in Table S.6.4.M.	

(Table Added 2013)

<u>Table S.6.4.</u>	
<u>Railway Track Scale – Weigh Module Capacity</u>	
<u>Weigh Module Length (ft)</u>	<u>Weigh Module Capacity (lb)</u>
<u>< 5</u>	<u>80 000</u>
<u>5 to < 10</u>	<u>160 000</u>
<u>10 to < 15</u>	<u>240 000</u>
<u>15 to < 23</u>	<u>320 000</u>
<u>23 to < 29</u>	<u>372 000</u>
<u>29 to < 35</u>	<u>424 000</u>
<u>35 to < 40</u>	<u>516 000</u>
<u>40 to < 56</u>	<u>568 000</u>
Note: The capacity of a particular module is based on its length and determined from corresponding capacity values specified in Table S.6.4.	

(Table Added 2013)

2. Add the following definition for the term “weigh module” to NIST Handbook 44, Appendix D:

weigh module – The portion of a load-receiving element supported by two sections. The length of a module is the distance to which load can be applied. [2.20]

Background/Discussion:

The nominal capacity of a railway track scale has historically been based on the capacity of the pivots or load cells supporting the various sections of the scale. Since pivots were generally the weakest element, this was logical. With the introduction of load cell technology, the capacity of a section could far outreach the capacity of the weighbridge. Weighbridge design, based on the requirements in the *AAR Scale Handbook*, must be capable of supporting 80 000 lb axles on five foot centers. With the introduction of combined short span weigh modules over multiple sections, the use of the section capacity to determine scale capacity provides both the opportunity for overloaded structures and/or the requirement to overdesign the section. Basing nominal scale capacity on both the

section capacity and the structural capacity is the best solution. Additionally, a 640 000 lb limit assures these scales can be calibrated with 12.5 % of capacity using the conventional 80 000 lb test weight equipment.

The changes to the nominal capacity specification were developed by Committee 34 - Scales, of the American Railway Engineering and Maintenance-of-Way Association (AREMA) and approved, by unanimous vote, for inclusion in the *AAR Scale Handbook*.

The original proposal to amend paragraph S.6.4. Railway Track Scales recommended: 1) striking out the two nonretroactive sentences in the paragraph, which linked nominal capacity to the number of sections of a railway track scale, and 2) adding new criteria for establishing a scale's nominal capacity based on the lesser of three considerations as follows:

1. the sum of the weigh module capacities;
2. a scale's rated sectional capacity multiplied by the number of sections of the scale minus the number of dead spaces minus 0.5; or
3. 640 000 lb.

The original proposal also recommended adding a new definition for "weigh module" and a new Table S.6.4. to NIST Handbook 44. The new table provided various capacity ratings of weigh modules based on weigh module length for use in determining the value of the first of the three considerations shown above.

Eliminating the two nonretroactive sentences in the paragraph as proposed would have had the effect of making the entire paragraph retroactive.

A number of significant changes to the original proposal were agreed to by the Committee relative to this item during the 2012 NCWM Interim and Annual Meetings as follows:

- During the Interim Meeting, the Committee agreed to add "the nominal capacity listed on the CC" to the list of proposed nominal capacity considerations to address concerns about the potential impact the proposal might have on existing equipment, especially equipment manufactured between the dates January 1, 2002, the effective date of enforcement of the nonretroactive portion of the current paragraph proposed for deletion, and the date the proposed changes to the paragraph would take effect. The Committee later agreed, during the Annual Meeting, to reverse that decision based on a concern expressed by OWM that if an NTEP CC corresponding to existing equipment were changed, that equipment may not be able to comply with proposed option of "the nominal capacity listed on the CC." As an alternative, the Committee agreed to divide the proposal into two parts assigning each part a different enforcement date.
- The Committee agreed, during the Interim Meeting, to amend the definition of "weigh module" originally proposed by deleting the words "single or articulated" as a descriptor in the definition. The Committee later agreed at the Annual Meeting to further modify the proposed definition by deleting the words "of the weighing element" from the proposed definition.
- The Committee also agreed to add a note beneath Table S.6.4. Railway Track Scale – Weigh Module Capacity to make clear that the module capacities are to be based on the length of the module and corresponding capacities specified in the proposed table.

Additionally, OWM commented during the 2012 NCWM Annual Meeting that they would likely include equivalent SI values in NIST Handbook 44, if the item were adopted.

In consideration of the number of changes made to the item over the course of the two meetings, the Committee agreed to delete the proposal under Item Under Consideration in 2012 NCWM Publication 16 and replace it with the following:

1. Amend NIST Handbook 44, Scales Code paragraph S.6.4. Railway Track Scales as follows:

S.6.4. Railway Track Scales. – A railway track scale shall be marked with the maximum capacity of each section of the load-receiving element of the scale. Such marking shall be accurately and conspicuously presented on, or adjacent to, the identification or nomenclature plate that is attached to the indicating element of the scale. ~~The nominal capacity of a scale with more than two sections shall not exceed twice its rated section capacity. The nominal capacity of a two section scale shall not exceed its rated section capacity.*~~

The nominal capacity marking shall satisfy the following.

- (a) **For scales manufactured from January 1, 2002, through December 31, 20XX:**
 - (1) **The nominal capacity of a scale with more than two sections shall not exceed twice its rated section capacity.**
 - (2) **The nominal capacity of a two section scale shall not exceed its rated section capacity.**
- (b) **For scales manufactured on or after January 1, 20XX, the nominal scale capacity shall not exceed the lesser of:**
 - (1) **The sum of the Weigh Module Capacities as shown in Table S.6.4, or;**
 - (2) **Rated Sectional Capacity (RSC) multiplied by the quantity of the Number of Sections (Ns) minus the Number of Dead Spaces (Nd) minus 0.5. As a formula this is stated as $RSC \times (Ns - Nd - 0.5)$; or**
 - (3) **640 000 lb.**

*[*Nonretroactive as of January 1, 2002]*

(Amended 1988, 2001, ~~and 2002,~~ and 20XX)

<u>Table S.6.4.M.</u>	
<u>Railway Track Scale – Weigh Module Capacity</u>	
<u>Weigh Module Length (m)</u>	<u>Weigh Module Capacity (kg)</u>
<u>< 1.5</u>	<u>36 300</u>
<u>1.5 to < 3.0</u>	<u>72 600</u>
<u>3.0 to < 4.5</u>	<u>108 900</u>
<u>4.5 to < 7.0</u>	<u>145 100</u>
<u>7.0 to < 9.0</u>	<u>168 700</u>
<u>9.0 to < 10.5</u>	<u>192 300</u>
<u>10.5 to < 12.0</u>	<u>234 100</u>
<u>12.0 to < 17.0</u>	<u>257 600</u>
<u>Note: The capacity of a particular module is based on its length and determined from corresponding capacity values specified in Table S.6.4.M.</u>	

(Table Added 20XX)

Table S.6.4.	
Railway Track Scale – Weigh Module Capacity	
<u>Weigh Module Length (ft)</u>	<u>Weigh Module Capacity (lb)</u>
<u>< 5</u>	<u>80 000</u>
<u>5 to < 10</u>	<u>160 000</u>
<u>10 to < 15</u>	<u>240 000</u>
<u>15 to < 23</u>	<u>320 000</u>
<u>23 to < 29</u>	<u>372 000</u>
<u>29 to < 35</u>	<u>424 000</u>
<u>35 to < 40</u>	<u>516 000</u>
<u>40 to < 56</u>	<u>568 000</u>
Note: The capacity of a particular module is based on its length and determined from corresponding capacity values specified in Table S.6.4.	

(Table Added 20XX)

2. Add the following definition for the term “weigh module” to NIST Handbook 44, Appendix D:

weigh module – The portion of a load-receiving element supported by two sections. The length of a module is the distance to which load can be applied. [2.20]

During the fall 2012 Regional Association Meetings, the CWMA and SWMA supported the item and recommended it be designated a Voting Item. The WWMA and NEWMA recommended it be an Information Item. Mr. Darrell Flocken (Mettler-Toledo, LLC), speaking on behalf of the SMA at both the WWMA and SWMA fall 2012 Regional Association Meetings, stated that the SMA supported the concept of the more recent changes that took place during the course of the 2012 NCWM Annual Meeting and would review the item at its November 2012 meeting.

See the 2012 Annual Report to review previous language and positions to amend NIST Handbook 44 Scales Code paragraph S.6.4.

During the 2013 NCWM Interim Meeting Open Hearings, Mr. Flocken, speaking on behalf of the SMA, supported the item.

NIST OWM recommended three additional changes to the proposal as follows:

1. Add a reference to Table S.6.4.M. in proposed new subparagraph S.6.4.(b)(1);
2. Delete the words “the quantity of” from proposed new subparagraph S.6.4.(b)(2) so that it reads as follows:

Rated Sectional Capacity (RSC) multiplied by ~~the quantity of~~ the Number of Sections (Ns) minus the Number of Dead Spaces (Nd) minus 0.5. As a formula this is stated as $RSC \times (Ns - Nd - 0.5)$; and
3. Add the metric equivalent of 640 000 lb to proposed new subparagraph S.6.4.(b)(3).

Mr. Rafael Jimenez (Association of American Railroad Transportation Technology Center), speaking on behalf of the AAR, and Mr. Steve Beitzel (Systems Associates, Inc.), supported the item with the changes suggested by OWM.

Based on the comments received during the Open Hearings, the Committee agreed to amend the proposal to include OWM’s three suggested changes to read as shown in the Item Under Consideration and designated the item as a Voting Item.

During the 2013 NCWM Annual Meeting Open Hearings, the Committee received comments from Mr. Flocken, speaking on behalf of the SMA, and Mr. Jimenez, speaking on behalf of the AAR, both in support of the item.

There were four positions posted on the NCWM 2013 Online Position Forum; three supported the proposal and the other was neutral to the proposal.

The Committee recommended the item be presented for a vote as shown in the Item Under Consideration.

320-2 W Table 4 – Minimum Test Weights and Test Loads

(This item was withdrawn.)

Source:

Fairbanks Scales, Inc. (2013)

Purpose:

Provide clarification regarding the minimum amount of test weights and test loads required for official tests of floor scales having nominal capacities of 3001 lb and greater.

Item Under Consideration:

Amend Scales Code Table 4. Minimum Test Weights and Test Loads as follows:

Table 4. Minimum Test Weights and Test Loads¹					
Devices in Metric Units			Devices in U.S. Customary Units		
Device Capacity (kg)	Minimums (in terms of device capacity)		Device Capacity (lb)	Minimums (in terms of device capacity)	
	Test Weights (greater of)	Test Loads²		Test Weights (greater of)	Test Loads²
0 to 150 kg	100 %		0 to 300 lb	100 %	
151 to 1 500 kg	25 % or 150 kg	75 %	301 to 3 000 lb	25 % or 300 lb	75 %
1 501 to 20 000 kg	12.5 % or 500 kg 25 % or 1 250 kg	50 %	3001 to 40 000 lb	12.5 % or 1 000 lb 25 % or 2 500 lb	50 %
20 001 kg+	12.5 % or 5 000 kg	25 % ³	40 001 lb+	12.5 % or 10 000 lb	25 % ³

Background Discussion:

Table 4. Minimum Test Weights and Test Loads specifies that the greater of 25 % of device capacity or 300 lb, as the minimum amount of test weight required for testing scales ranging in capacity from 301 to 3000 lb. The 25 % specified in Table 4 corresponds with the amount required by the shift test procedures described in subparagraph N.1.3.7.(b), which allows, as an option, the shift test to be performed using a one-quarter nominal capacity test load centered as nearly as possible, successively, over each corner of the load-receiving element.

There is inconsistency in minimum test weight requirements between Table 4 and paragraph N.1.3.7. for scales of other capacities. Consider a 10 000 lb capacity floor scale as an example. Table 4 requires a minimum of only 12.5 % of scale capacity in test weights, which equates to 1250 lb. Subparagraph N.1.3.7.(b) requires 25 % of nominal capacity in test load, or in this example 2500 lb, to perform the shift test. The differences in these two

requirements could become an issue in states that enforce NIST Handbook 44. There should be consistency in the minimum test weights required and the weights required in performing a shift test.

One could argue that the shift test can be performed using substitutions along with test weights. However, N.1.3.7.(b) can be interpreted as specifically defining “test loads” as “test weights” for the purpose of that paragraph.

At the fall 2012 NEWMA Meeting, it was reported that some believe this item would be a safety concern (because of the increased amount of test weight that would be needed to test such scales if this proposal were accepted). NEWMA suggested retaining the 12.5 % currently specified in Table 4 and stated that more information would be needed to support the item. NEWMA forwarded the item to NCWM, recommending it as a Developing Item.

During the 2013 Interim Meeting Open Hearings, the S&T Committee heard comments from Mr. Lou Straub (Fairbanks Scales) recommending that the item be withdrawn because the changes proposed to Table 4 shown in Item Under Consideration, if accepted, would not solve the problem identified by the submitter as reported on NCWM Form 15. Using a 10 000 lb capacity floor scale as an example to illustrate his point, Mr. Straub explained that Table 4 requires a minimum of 1250 lb in test weight and that subparagraph N.1.3.7.(b) specifies that either a one-third or one-quarter nominal capacity test load be used to conduct the shift test, depending upon the position of the test load on the platform. One-quarter nominal capacity, the lesser of the two fractions specified in subparagraph N.1.3.7.(b) equates to 2500 lb on a 10 000 lb capacity. Thus, it appeared to the Fairbanks technician, who submitted this proposal, that there was a conflict in the amount of test weight required by Table 4 and subparagraph N.1.3.7.(b), to perform an official test.

Mr. Straub further explained to the Committee that, whereas a one-third nominal capacity test load is explicitly defined as “test weight” in subparagraph N.1.3.7.(b), a one-quarter nominal capacity test load, which is also referenced in the same subparagraph is not. In reviewing past NCWM Conference Reports relating to paragraph N.1.3.7., he concluded that the one-quarter nominal capacity test load referenced in subparagraph (b) was purposely not defined because it was intended for that test load to be comprised of either all test weight or a combination of test weight and substituted material. By not defining the one-quarter nominal capacity shift test load as test weight, one could conduct a shift test on a 10 000 lb capacity scale using a combination of 1250 lb of test weight (i.e., the minimum amount of test weight specified in Table 4 for a 10 000 capacity scale) and a single substitution test load. That is, a substitution test load used in combination with the test weight could create a shift test load equal to 2500 lb (one-quarter nominal capacity). This being the case, there is no conflict concerning the amount of test weight required by the two NIST Handbook 44 requirements.

Mr. Straub also indicated that another factor contributing to his recommendation to withdraw this item is the fact that paragraph N.1.3.7. does not, in any way, preclude someone from conducting the shift test using a one-quarter nominal capacity test load comprised entirely of test weight. In conclusion, he suggested that the Committee may want to consider adding a footnote to subparagraph N.1.3.7.(b) to make clear that the one-quarter nominal capacity test load can be comprised of either test weight entirely or a combination of test weight and substitution test loads.

The Committee also heard comments from Mr. Darrell Flocken (Mettler-Toledo, Inc.), speaking on behalf of the SMA. Mr. Flocken indicated that the SMA was opposed to the item as written because they do not believe the agenda item aligns with the recommendation as written in the original NCWM Form 15.

NIST OWM noted that it is only reasonable to expect that the amount of test weight specified in NIST Handbook 44 for a shift test be not greater than the minimum amount of test weight required to certify a scale. Rather than proposing to increase the amount of test weight required to perform an official test on all scales having capacities between 3001 lb and 40 000 lb, OWM suggested that the submitter might consider amending the Item Under Consideration so that its impact would be limited to only those scales having been identified in the proposal as being of concern, that is, those having capacities between 3001 lb and 10 000 lb. Jurisdictions might also find this to be a more reasonable approach. With regard to the possibility that paragraph N.1.3.7. might be misinterpreted, OWM noted that the paragraph is very clear in defining one-third nominal capacity test load as “test weight.”

In consideration of Fairbanks Scales’ recommendation to withdraw the item and SMA’s opposition to the item, the Committee agreed to withdraw it. The Committee also agreed that it was not necessary to add a footnote to

paragraph N.1.3.7.(b) to clarify that a one-quarter capacity test load could be comprised of either test weight entirely or a combination of test weight and substitution test loads because there is already a footnote in Table 4 defining the term “test load.”

During the 2013 NCWM Annual Meeting Open Hearings, Mr. Flocken, speaking on behalf of the SMA, and Mr. Straub (Fairbanks Scales) supported withdrawing the item. OWM reiterated the comments it provided during the 2013 NCWM Interim Meeting.

No further action was taken by the Committee at the 2013 NCWM Annual Meeting since the Committee had previously agreed to Withdraw the item.

320-3 W T.N.3., Table 6. Maintenance Tolerances

(This item was withdrawn.)

Source:

Michigan Department of Agriculture (2013)

Purpose:

Provide additional guidance concerning the proper application of NIST Handbook 44, Scales Code, Table 6. Maintenance Tolerances.

Item Under Consideration:

Amend Scales Code Table 6. Maintenance Tolerances as follows:

Table 6. Maintenance Tolerances (All values in this table are in scale divisions)					
Tolerance in Scale Divisions					
	1d	2d	3d	5d	
Class	Test Load in Divisions				
I	0 - 50 000	50 001 -	200 000	200 001 +	
II	0 - 5 000	5 001 -	20 000	20 001 +	
III	0 - 500	501 -	2 000	2 001 -	4 000 4 001 +
IIII	0 - 50	51 -	200	201 -	400 401 +
III L	0 - 500	501 -	1 000	(Add 1 d for each additional 500 d or fraction thereof)	

Note:

In order to determine the number of divisions for any test load; divide the value of the mass standard being applied by the minimum division indicated by the scale.

Example: If the scale has a minimum division of 0.1 g and a 1500 g mass standard is applied, the test load is equal to 15 000 divisions.

Result: On a Class II scale with a test load between 5001 and 20 000 divisions indicates the tolerance is ± 2 divisions or ± 0.2 g.

Background/Discussion:

2012 CWMA Interim Meeting: Table 6 is located in NIST Handbook 44; however, the instructions for use are located in NIST Handbook 133. This amendment would aid service companies who may be unaware of NIST Handbook 133, or those technicians who may have been told what the tolerances are but not trained on how to

determine those numbers. Based on suggestions from regulatory officials, the submitter’s original proposal was modified to add “d” to the column headings and to rewrite the new guidance as a note and include an example. CWMA supported the item as amended and forwarded it to NCWM, recommending it as a Voting Item.

At the 2013 NCWM Interim Meeting, Mr. Darrell Flocken (Mettler-Toledo, Inc.), speaking on behalf of the SMA supported the item, but recommended:

1. That the term “mass standard” be changed to “test weight(s)” in both the “Note” and the “Example” sentences.
2. That the two sentences, the first of which follows the word “Example” and the second of which follows the word “Result” in the Item Under Consideration be combined as an example to read:

Example: If the scale has A Class II scale with a minimum division of 0.1 g and a 1500 g mass standard test weight(s) is applied, the test load is equal to 15 000 divisions, resulting in a tolerance is of ± 0.2 g.

Result: On a Class II scale with a test load between 5001 and 20 000 divisions indicates the tolerance is ± 2 divisions or ± 0.2 g.

NIST OWM commented that it would be inappropriate to include the letter “d” after each tolerance multiple as shown in Table 6 of the Item Under Consideration because in cases where the value of $d \neq e$ (such as on some Class I and II scales, dynamic monorails, etc.) a factor of the value of “e,” rather than “d,” is used to determine the applicable tolerances. Likewise, in the proposed note and associated example, it would be technically incorrect, in some cases, to refer to the division as “minimum” because the minimum division indicated by the scale would be the value of “d” and “d” would not necessarily be used to determine the number of divisions for any test load. In cases where the value of $d \neq e$, the number of divisions for any test load would be determined by dividing the test load value by the verification division (e). For these reasons, it is OWM’s opinion that the proposed changes would tend to confuse rather than aid those not very familiar with how the values in Table 6 are to be applied.

Ms. Kristen Macy (California) commented that she agreed with OWM’s comments and that the changes proposed in the Item Under Consideration would only apply in cases where the value of “d” and “e” are equal.

NIST OWM developed the following alternative changes to Table 6 and provided them to the Committee for consideration should the Committee decide that additional clarification of the values in Table 6 were needed:

Table 6.				
Maintenance Tolerances				
(All values in this table are in scale divisions)				
	Tolerance in Scale Divisions (d or e)*			
	1	2	3	5
Class	Test Load in Scale Divisions (d or e)*			
I	0 - 50 000	50 001 - 200 000	200 001 +	
II	0 - 5 000	5 001 - 20 000	20 001 +	
III	0 - 500	501 - 2 000	2 001 - 4 000	4 001 +
III	0 - 50	51 - 200	201 - 400	401 +
III L	0 - 500	501 - 1 000	(Add 1 d for each additional 500 d or fraction thereof)	

***In cases where $d \neq e$, for example, some Class I and II scales, dynamic monorail scales, etc., the value of “e” is used to determine tolerance and test load. In all other cases the value of “d” is to be used.**

OWM noted that a somewhat different approach to amending Table 6 in an effort to improve understanding would be to develop and present a separate table in NIST Handbook 44 for each scale accuracy class. An example draft table for Class I scales was developed by OWM and also provided to the Committee to show how these could be used as an alternative to amending Table 6.

The following additional comments and recommendations relating to the Item Under Consideration were also provided by OWM:

- If a note is needed to explain how to calculate the number of scale divisions in the test load, OWM suggests expressing the example as a formula and offers the following for consideration:

$$\text{Test Load in Scale Divisions} = \frac{\text{Test Load in Units of Mass}}{\text{Value of Scale Division (d or e) in Units of Mass}}$$

- With regard to the proposed example, the Committee might wish to consider suggesting that the example be included in a field manual, EPO, or other guidance document, rather than in NIST Handbook 44.
- Should the Committee decide to modify Table 6 by adding additional clarifications concerning which value (“d” or “e”) applies, it might also consider amending various other paragraphs in NIST Handbook 44 where both (d) or (e) could apply, yet, neither is specified, or only one of the two is specified within the paragraph (e.g., paragraphs S.2.1.3.1, S.2.1.3.2., N.1.2.1., T.N.1.2., T.N.7.2., etc.).

In considering this item, the Committee agreed with the comments received from NIST OWM and the State of California that it would be inappropriate to include the letter “d” after each tolerance multiple without also including some explanation of how the values in the table would apply in cases where the value of “d” and “e” are different on a scale. The NIST Technical Advisor pointed out to the Committee that in the United States, the term “scale division” is often used interchangeably to reference both scale division (d) and verification scale division (e) and that, unless the term is further defined, it is unknown which value is being referenced. Adding the letter “d” after each tolerance multiple as proposed in the Item Under Consideration would provide additional clarification by defining the tolerance values as scale division (d) opposed to verification scale division (e). Such clarification would be inappropriate because the tolerances in Table 6 must also be applied to scales having a value of “d” that is different than “e” and in such cases, tolerances must be determined in values of “e.”

The Committee considered how the table might be amended or the information in the table presented to provide a better understanding of how tolerances are to be determined given that the table applies to not only scales where the value of “d” and “e” are the same, but also to scales where the values are different. The Committee considered OWM’s alternative changes to the table and whether or not a separate table in NIST Handbook 44 for each scale accuracy class would make it any easier for those less experienced to understand how to determine and apply tolerances. The Committee concluded that there is no simple means of making the information in the table easier to understand or presenting it in a way that would improve understanding for inexperienced inspectors or service personnel who have not received training. The Committee agreed that regardless of how the table was changed or the information in the table presented, training would still be needed to teach how the values in the table are to be applied. With training comes the understanding that “d” and “e” are not always equal for all classes of scales and how to use those values to determine the tolerance and test loads specified in Table 6. Additionally, the definition in Appendix D for “verification scale division” and paragraph S.1.2.2. Verification Scale Interval clarifies how “d” and “e” are to be applied. In considering OWM’s alternative approach of developing and presenting a table for each scale accuracy class, the Committee preferred that scale tolerances for all scale accuracy classes remain in a single condensed table. The Committee also agreed that examples to make clear how tolerances are to be applied are better included in training material rather than NIST Handbook 44. The Committee indicated that it understood and appreciated the concerns raised by the submitter of this item, but didn’t believe the changes proposed to NIST Handbook 44 would be beneficial, and, therefore, agreed to Withdraw this item.

During the 2013 NCWM Annual Meeting Open Hearings, Mr. Flocken, speaking on behalf of the SMA, commented that the SMA opposes the withdrawal of this item and recommends the item be returned to an “Information” status

because the SMA believes this item has value in clarifying the use of the information in the table. Once the item becomes “Informational,” the following changes should be considered:

1. Change the term “mass standard” to “test weight(s)” in both the “Note” and the “Example” sentences.
2. Combine the “Example” and “Result” sentences to read:

Example: If the scale has A Class II scale with a minimum division of 0.1 g and a 1500 g mass standard test weight(s) is applied, the test load is equal to 15 000 divisions, resulting in a tolerance is of ± 2 divisions or ± 0.2 g.

Result: On a Class II scale with a test load between 5001 and 20 000 divisions indicates the tolerance is ± 2 divisions or ± 0.2 g.

3. The actual tolerance value in Table 6 should not be identified as “d” because the verification scale interval for a Class I and II instrument is “e”.
4. Add the phrase “(as required by the Instruments Class designation)” after the words “Tolerance in Scale Divisions.”

Ms. Julie Quinn (Minnesota) supported returning the item to “Informational” status commenting that Table 6 is very confusing and that service technicians, especially, have difficulty understanding the table.

OWM reiterated the comments it provided during the 2013 Interim Meeting.

In discussing this item during its work session, the Committee once again concluded, as it had at the 2013 Interim Meeting, that regardless of how the table was changed or the information in the table presented, training would still be needed to teach how the values in the table are to be applied. The Committee agreed that the best approach to resolving confusion over the application of the table is through training and examples provided in the NIST EPOs. The Committee decided to withdraw the item noting that its decision to do so would not preclude someone or group from proposing a new item to better clarify how the values in Table 6 are to be applied.

320-4 VC Appendix C – Units of Mass (ton)

(This item was adopted.)

Source:

Rice Lake Weighing Systems, Inc. (2012)

Purpose:

Establish uniform abbreviations for “short ton.”

Item Under Consideration:

1. Amend the Units of Mass Table that appears on pages C-19 and C-20 of NIST Handbook 44 Appendix C to recognize “tn” as an acceptable abbreviation for “net” or “short” ton, and add a footnote to make clear that abbreviations for “net” or “short” ton other than “tn” are considered appropriate for use with older equipment. The following changes are proposed:

Units of Mass	
1 assay ton ¹⁷ (AT)	29.167 grams
1 carat (c)	200 milligrams (exactly) 3.086 grains
1 dram apothecaries (dr ap or ʒ)	60 grains (exactly) 3.888 grams
1 dram avoirdupois (dr avdp)	27 ¹¹ /32 (= 27.344) grains 1.772 grams
1 gamma (γ)	1 microgram (exactly)
1 grain	64.798 91 milligrams (exactly)
1 gram (g)	15.432 grains 0.035 ounce, avoirdupois
1 hundredweight, gross or long ¹⁸ (gross cwt)	112 pounds (exactly) 50.802 kilograms
1 hundredweight, gross or short (cwt or net cwt)	100 pounds (exactly) 45.359 kilograms
1 kilogram (kg)	2.205 pounds
1 milligram (mg)	0.015 grain
1 ounce, avoirdupois (oz avdp)	437.5 grains (exactly) 0.911 troy or apothecaries ounce 28.350 grams
1 ounce, troy or apothecaries (oz t or oz ap or ʒ)	480 grains (exactly) 1.097 avoirdupois ounces 31.103 grams
1 pennyweight (dwt)	1.555 grams
1 point	0.01 carat 2 milligrams
1 pound, avoirdupois (lb avdp)	7000 grains (exactly) 1.215 troy or apothecaries pounds 453.592 37 grams (exactly)
1 micropound (μlb) [the Greek letter mu in combination with the letters lb]	0.000 001 pound (exactly)
1 pound, troy or apothecaries (lb t or lb ap)	5760 grains (exactly) 0.823 avoirdupois pound 373.242 grams
1 scruple (s ap or ʒ)	20 grains (exactly) 1.296 grams
1 ton, gross or long ¹⁹	2240 pounds (exactly) 1.12 net tons (exactly) 1.016 metric tons
1 ton, metric (t)	2204.623 pounds 0.984 gross ton 1.102 net tons
1 ton, net or short (tn) ^x	2000 pounds (exactly) 0.893 gross ton 0.907 metric ton

¹⁷ Used in assaying. The assay ton...¹⁸ The gross or long ton and hundredweight are used commercially in the United States to only a very limited extent, usually in restricted industrial fields. The units are the same as the British “ton” and “hundredweight.”
¹⁹ The gross or long ton...

As of January 1, 2014, “tn” is the required abbreviation for “short ton.” Devices manufactured between January 1, 2008, and December 31, 2013, may use an abbreviation other than “tn” to specify “short ton.”

Assign the appropriate footnote sequence number to “x” in the table and footnote shown above and renumber subsequent footnotes in Appendix C.

- Amend the abbreviation “t” for 1 ton (20 hundredweights) beneath the Avoirdupois Units of Mass heading on page C-6 of NIST Handbook 44 Appendix C to “tn” and add the same footnote as is proposed for addition in Item Under Consideration 1. above to again make clear that abbreviations for “net” or “short” ton other than “tn” are considered appropriate for use with older equipment. The following changes are proposed:

Avoirdupois Units of Mass⁶

[The “grain” is the same in avoirdupois, troy, and apothecaries units of mass.]

1 μlb	= 0.000 001 pound (lb)
27 ¹¹ / ₃₂ grains (gr)	= 1 dram (dr)
16 drams	= 1 ounce (oz)
	= 437 ¹ / ₂ grains
16 ounces	= 1 pound (lb)
	= 256 drams
	= 7000 grains
100 pounds	= 1 hundredweight (cwt) ⁷
20 hundredweights	= 1 ton (†) (tn) ⁸
	= 2000 pounds ⁷

In “gross” or “long” measure, the following values are recognized:

112 pounds (lb)	= 1 gross or long hundredweight (cwt) ⁷
20 gross or long hundredweights	= 1 gross or long ton
	= 2240 pounds ⁷

⁶ When necessary to distinguish...

⁷ When the terms “hundredweight” and...

As of January 1, 2014, “tn” is the required abbreviation for “short ton.” Devices manufactured between January 1, 2008, and December 31, 2013 may use an abbreviation other than “tn” to specify “short ton.”

Assign the appropriate footnote sequence number to “x” in the table and footnote shown above and renumber subsequent footnotes in Appendix C.

Background/Discussion:

The submitter of this item discovered a difference between United States and Canadian abbreviation requirements that may impact manufacturers that sell products in both countries and NTEP type evaluations under the United States/Canada mutual recognition program. Most units of mass have an abbreviation for SI and U.S. customary units (e.g., kg, lb, g, oz). However, the same abbreviation, the lower case “t,” is used to represent both the metric ton and the short ton (2000 lb). If an indicator is set up to display both SI and U.S. customary units, the operator or customer cannot know what units are being displayed if “t” is the only abbreviation that is acceptable for metric ton. Because of the limited space available on today’s indicators, the words “short ton” or “long ton” are not always an option.

In the Canadian Lab Manual, Part 2, Section Appendix-2A in the table for abbreviations and symbols accepted in Canada, metric ton is abbreviated by “t” and short ton is abbreviated by “tn.” In NCWM Publication 14, Appendix C in a table titled “Acceptable Abbreviation/Symbols” there is an abbreviation of “TN” for short ton and “LT” for long ton. In keeping with the Canadian abbreviation, the Committee considered a request that NIST Handbook 44 be amended to use the lower case “tn” and “lt” as the abbreviations for short and long ton respectively.

During the 2012 NCWM Interim Meeting, the original submitter, Mr. Paul Lewis (Rice Lake Weighing Systems, Inc.) requested that the proposal in the Interim Agenda be modified to remove the reference to “long ton” and its associated proposed abbreviation “lt.” Mr. Lewis indicated that the intent of the proposal is to align United States and Canadian requirements and noted that the abbreviation “tn” is an acceptable Canadian abbreviation for “short ton.” The Committee agreed to remove the reference to “long ton” in the Units of Mass table on page C-19 of NIST Handbook 44, Appendix C as was requested by the submitter of the proposal.

See the 2012 Annual Report to review previous language and positions to recognize “tn” as an acceptable abbreviation for “net” or “short” ton in NIST Handbook 44.

Comments received during the Open Hearings of the fall 2012 Regional Weights and Measures Associations were predominantly in support of the item. At the fall 2012 CWMA Interim Meeting, industry requested that the Committee support a change to “short ton” to align with Measurement Canada. The WWMA acknowledged potential conflict with the abbreviation of “tn” for “net” or “short ton” in NCWM Publication 14 BCS-4, yet reported there was no opposition to the item and it appeared that concerns raised in the Background/Discussion had been resolved. Mr. Darrell Flocken (Mettler-Toledo, Inc.), speaking on behalf of the SMA during the WWMA and SWMA, indicated the SMA supported the item. Three of the regional weights and measures associations recommended the item be Voting and NEWMA recommended it remain Informational.

During the 2013 NCWM Interim Meeting Open Hearings, NIST OWM commented that conflicts in the abbreviation for “short” or “net” ton in NIST Handbook 44 and NCWM Publication 14 are of continued concern and noted the following:

- NIST Handbook 44 (Appendix C) recognizes the lower case “t” as an acceptable abbreviation for both the U.S. short ton and the metric ton. NIST Handbook 44 does not recognize upper case “T” as an acceptable abbreviation for the U.S. short ton or metric ton, nor does it recognize upper case “LT” as an acceptable abbreviation for the U.S. long ton.
- A table included on page BCS-4 of the 2012 NCWM (NTEP) Publication 14, Belt Conveyor Scales (BCSs) Checklists and Test Procedures indicates the U.S. short ton may be identified as “ton” or upper case “T;” the metric ton as lower case “t;” and the U.S. long ton as upper case “LT.” The following abbreviations appear in the 2012 version of Pub 14 BCSs type evaluation criteria:

Unit	Abbreviation
pounds	lb or LB
U.S. short ton	ton or T
U.S. long ton	LT
Metric ton	t
kilograms	kg

The word “ton” is not an abbreviation although it is included in the NCWM Publication 14 table as such.

- Because upper case “T” and upper case “LT” are recognized by NTEP as acceptable abbreviations for U.S. short ton and U.S. long ton, respectively, it can only be assumed that there are BCSs currently in commercial service that have been issued an NTEP CC that use these abbreviations.

- By virtue of the fact that paragraph G-S.5.6.1. specifies the locations of where appropriate abbreviations for equipment manufactured as of January 1, 2008, may be found; if a particular defining symbol observed during inspection is not included in those locations, it infers that that particular symbol is inappropriate, disallowed, and would necessitate official rejection. Thus, if an official were to observe the abbreviation “T” or “LT” during an inspection of a BCS that was manufactured as of January 1, 2008, regardless of which “ton” was intended to be identified, they should reject for failure to comply with the provisions of G-S.5.6.1. even though an active CC may be linked to the device.
- If the proposed change is adopted and “tn” was to become an acceptable abbreviation for U.S. “short ton,” Publication 14 BCSs would be revised to reflect the change. How will officials apply the revised abbreviation to existing equipment that designate short tons using upper case “T” or other abbreviations? Wouldn’t accepting the additional abbreviation “tn” for the U.S. short ton only add to an already existing, and somewhat confusing problem?
- A more reasonable approach it would seem, is to first fix the current problem, perhaps by agreeing on one or maybe two, acceptable abbreviations for each type of ton and then specifying what those agreed upon abbreviations are in both NIST Handbook 44 and NCWM Publication 14. Additionally, it might be agreed that when the word ton is not abbreviated, it must be further qualified by a preface clarifying which ton is being referenced. As OWM has noted before, even if everyone were to agree on different acceptable abbreviations for the U.S. short or net ton, the U.S. long ton, and the metric ton, it would be unlikely that this would completely resolve all the confusion relating to the value of the ton in commercial transactions. The spelled-out version of the word “ton” is often used instead of its abbreviation to identify values displayed or recorded by a commercial device. Thus, unless the word “ton” is further qualified using an appropriate clarifying preface such as “metric,” “short,” “net,” or “long,” it’s unclear as to which ton is being referenced when the word “ton” by itself is used to identify the unit of measure.

As a final comment, OWM recommended that, should the Committee decide to move forward with the proposal, the Committee should consider changing the abbreviation “t” (which refers to 1 ton (short), beneath the heading “Avoirdupois Units of Mass” on page C-6 of the 2012 version of NIST Handbook 44) to “tn” to avoid conflict with the recommended proposal.

The submitter of the proposal, Mr. Lewis, commented that the intent of the proposal is to harmonize the abbreviation for “short ton” with Measurement Canada’s requirements.

Mr. Flocken, speaking on behalf of the SMA, indicated that the SMA supported the item.

During its deliberations, the Committee considered how to address concerns regarding how officials are to treat equipment with an existing CC that uses an abbreviation for short ton that differs from the “tn” abbreviation proposed, should this item be adopted. Paragraph G-S.5.6.1. specifies the locations of where appropriate abbreviations for equipment manufactured as of January 1, 2008, may be found and NIST OWM commented during the Open Hearings that if a particular defining symbol observed during inspection is not included in those locations, it infers that particular symbol is inappropriate, disallowed, and would necessitate official rejection. If “tn” is made the acceptable abbreviation for “short ton” and is added to Appendix C of NIST Handbook 44 as proposed, how are officials to apply paragraph G-S.5.6.1. to existing equipment that uses an abbreviation other than “tn” that was manufactured on or after January 1, 2008 [i.e., the enforcement date of G-S.5.6.1.(a)]?

The Committee acknowledged that the change proposed, if adopted, would affect some existing equipment that use an abbreviation for short ton that might currently be considered acceptable, but with this change, would cause that abbreviation to be unacceptable. In consideration of this point, the Committee reported that they were interested in hearing input from those anticipating that this change would be detrimental to their equipment.

The Committee agreed to designate this as a Voting Item and, in an effort to address the concerns raised by OWM regarding the treatment of existing equipment, to add a new footnote to Appendix C in the Units of Mass Table immediately following the abbreviation “tn,” as shown in the Item Under Consideration.

The Committee also agreed with OWM's suggestion to change the abbreviation "t," which refers to "1 ton (short)," beneath the heading "Avoirdupois Units of Mass" on page C-6 of the 2013 version of NIST Handbook 44 to "tn" and add the same new footnote immediately following the amended abbreviation as shown in the Item Under Consideration.

During the 2013 NCWM Annual Meeting Open Hearings, the Committee heard comments in support of the item from Mr. Flocken, speaking on behalf of the SMA, and Mr. Ripka (Thermo Fisher Scientific).

OWM acknowledged that the footnote added by the S&T Committee during the 2013 Interim Meeting addressed the concern it had previously raised regarding how these abbreviations will be applied to existing as well as newly installed equipment. However, as noted before, should the proposal be adopted it will conflict with existing references in Publication 14; DES Appendix C includes references to "T" and "LT" as acceptable abbreviations. Thus, OWM encouraged each sector to review Publication 14 for any references to abbreviations for consistency with the proposed changes to NIST Handbook 44. The NIST Technical Advisors to the WS and BCS plan to ask those sectors to review Publication 14 for consistency with the abbreviations proposed in the Item Under Consideration.

OWM also expressed continued concern about the use of qualifying terms associated with the word "ton." The spelled-out version of the word "ton" is often used instead of one of its many abbreviations to identify values displayed or recorded by a commercial device. Unless the word "ton" is further qualified using an appropriate clarifying preface such as "metric," "short," "net," or "long," it is questionable as to which ton is being referenced when the word "ton" by itself is used to identify the unit of measure.

There were three positions posted on the NCWM 2013 Online Position Forum; one of which supported the proposal and the other two were neutral to the proposal.

The Committee recommended the item be presented for Vote as proposed.

320-5 I Part 2.20. Weigh-In-Motion Vehicle Scales for Law Enforcement – Work Group

Note: This item was originally numbered 360-4 in the Committee's 2013 Interim Report. This item was moved to the 320 Scales Section and renumbered 320-5 during the Committee's Open Hearings.

Source:

NIST, OWM, Mr. Richard Harshman, on behalf of the U.S. Federal Highway Administration (FHWA) (2011)

Purpose:

To provide the U.S. Weights and Measures community (equipment manufacturers, weights and measures officials, truck weight enforcement officials, and other users) with legal metrology requirements to address Weigh-in-Motion (WIM) systems used for vehicle enforcement screening.

Item under Consideration:

Adopt the proposed Section 2.25. Weigh-In-Motion Systems Used for Vehicle Enforcement Screening Code shown in Appendix B as a tentative code in NIST Handbook 44, and adopt the proposed definitions of terms used in the tentative code (also included in Appendix B) into NIST Handbook 44 Appendix D - Definitions.

Background/Discussion:

The Nation's highways, freight transportation system, and enforcement resources are being strained by the volume of freight being moved and the corresponding number of commercial vehicles operating on its roads. Traditional, static-based vehicle inspection activities simply cannot keep pace with anticipated truck volume increases. Current U.S. Department of Transportation (DOT) forecasts project freight volumes to double by 2035 and commercial vehicles to travel an additional 100 billion miles per year by 2020. WIM technology has been targeted by FHWA and Federal Motor Carrier Safety Administration as a technology capable of supporting more effective and efficient truck weight enforcement programs.

Several DOT efforts are underway and planned for the future to maintain adequate levels of enforcement that ensure equity in the trucking industry market and protection of highway infrastructure. Judicial support for enforcement decisions to apply more intense enforcement actions on specific trucks depends on support from the U.S. legal metrology community. Standards are needed in NIST Handbook 44 to address the design, installation, accuracy, and use of WIM systems used in a screening/sorting application. The implementation of a uniform set of standards will greatly improve the overall efficiency of the Nation's commercial vehicle enforcement process.

Once adopted by the truck weight enforcement community, these requirements will enhance the accuracy of the Nation's WIM scale systems; serve as a sound basis for judicial support of next-generation truck weight enforcement programs; and result in fewer legally loaded vehicles being delayed at static weigh station locations, thus reducing traffic congestion and non-productive fuel consumption and improving the movement of freight on our nation's roadways.

Purpose of the Project:

The FHWA's Office of Freight Management and Operations recognized a need to encourage uniformity in the design, testing, installation, and performance of WIM technology and subsequently encourage acceptance by prosecution agencies (administrative or judicial) regarding the validity of WIM technology's role in supporting commercial motor vehicle weight enforcement.

In response to this need and recognizing the value of having a standard included in NIST Handbook 44 because it lends integrity and is more recognizable in legal actions, the FHWA seeks to integrate WIM technology into the Handbook. The FHWA contracted the services of the Texas Transportation Institute—The Texas A&M University System and Battelle (a private company) to begin this process. Additionally, a small oversight Committee was formed by the FHWA, made up of three representatives from the FHWA, a NIST Technical Advisor, and a representative of a U.S. manufacturer of WIM equipment to validate that each contract deliverable is completed according to contract. NIST OWM agreed to provide a technical advisor to the associated work group tasked with development of the proposed code.

The intended application of the proposed new code is for screening purposes only (i.e., for screening/sorting commercial vehicles for possible violations of FHWA vehicle weight requirements).

The dates and descriptions below under the heading "Timeline of Completed Tasks Relating to the Project" are intended to provide an updated summary on the progress of the project since its inception.

Timeline of Completed Tasks Relating to the Project:

December 2010: A detailed project work plan, intended to guide activities and establish lines of communication from project inception to project completion, is developed. At about this same time, the NCWM and the S&T Committee are contacted and made aware of the project. Members of the NCWM S&T Committee are invited to participate on the USNWG charged with developing WIM standards that is about to be formed.

April 2011: A USNWG is established from the WIM stakeholder community comprised of representatives from state departments of transportation, state law enforcement agencies, weights and measures officials, WIM technology manufacturers and vendors, academic researchers, and others.

July 2011: The USNWG holds its first face to face meeting. Mr. Darrell Flocken (Mettler-Toledo, Inc.) accepts the position of WIM USNWG chair, and encourages stakeholders to submit comments to the work group. During the meeting, Mr. Rick Harshman, (NIST OWM) Technical Advisor to the USNWG, presents an overview of the process to develop the technical content of a new WIM Code. He explains how NIST Handbook 44 is organized and how requirements developed by the USNWG will fit into the various sections of a new NIST Handbook 44 code. He also provided an overview of the standards development process and discusses the benefits of the USNWG using an example draft code, which he had already created to develop the new draft code. Mr. Steve Langford (Cardinal Scale Manufacturing Co.) gives a presentation on the NIST Handbook 44 amendment process, which detailed the various steps the USNWG will need to complete to add a new device code to NIST Handbook 44.

Several concerns/questions are raised by participants during the open discussion portion of the meeting. The following are some of the most important concerns/questions discussed:

- The application section of the code is critical. The types of WIM systems in which the code does and does not apply will significantly impact all other sections of the code.
- What tolerance should be specified in the draft code? An important related question is: What degree of accuracy will the judicial system (courts) accept as being sufficiently accurate enough to screen commercial vehicles for possible overweight violations? The degree of accuracy required will have a large impact on the kinds of systems that get included or excluded in the application section of the code.
- There needs to be a separation of requirements. That is, a separation of requirements that apply to virtual weigh stations and those that apply to WIM systems installed at weigh stations having a static scale.
- To adopt a draft code at the national level, two things must happen: 1) A legitimate test procedure is needed to enable states to test these systems; and 2) federal funding is needed to help cover the cost of testing.
- Will NCWM Publication 14 type evaluation criteria be needed since these systems are not commercial and are unlike other devices typically covered by NIST Handbook 44?

The USNWG agreed to discuss these concerns/questions and any others brought to their attention during their next meeting.

November 2011: The example draft code developed earlier by Mr. Harshman, along with a checklist developed by Mr. Flocken is distributed to members of the USNWG. Participants are asked to complete the checklist as they review the draft code, identifying sections within the draft code, which they believe need additional work.

May 2012: The first working draft of a WIM Code is developed based on comments received from the draft code and checklist that had been previously distributed in November 2011. A separate draft document containing definitions of terms that may need to be added to Appendix D of NIST Handbook 44 is also developed.

October 2012: Following a delay due to funding issues within the FHWA, the first working draft code and draft definitions are distributed to members of the USNWG for discussion at the next face to face meeting, which is scheduled November 2012.

November 2012: The USNWG conducts their second face to face meeting. During the meeting, the first working draft WIM Code is reviewed, discussed, and revised. Members of the USNWG agree that the revised draft code and associated definitions should be submitted to the NCWM for review and comment. The revised draft and associated definition documents are forwarded to the Chairman of the 2013 S&T Committee and to the NCWM. NCWM agrees to post these documents onto its website and notifies members of their presence.

See the 2012 Annual Report (S&T Agenda Item 360-3) for additional background information and summary updates of the 2012 Regional Weights and Measures Association Meetings and 2012 NCWM Meetings relating to this item.

2013 NCWM Interim Meeting Open Hearings: Mr. Flocken recommended that the Committee consider moving this item forward as an Information item so that it might be provided a greater level of consideration by the weights and measures community. Mr. Flocken reported that a new Draft WIM Code had recently been developed by members of the USNWG, and, although not perfect, the consensus of the USNWG is that it is ready for an initial review. There are two parts to the draft code, one of which is the draft code itself and the other is a document containing definitions of terms used in the draft code. Both have been posted and are available for review from the NCWM website. The USNWG is requesting feedback from the weights and measures community on both parts of the draft.

Additional comments in support of the draft were heard during the Open Hearings from members of the FHWA's Project Oversight Committee, the SMA, and a State of Florida DOT enforcement official. Based on the comments in support of this item, the Committee designates the item Informational.

2013 NCWM Annual Meeting Open Hearings: Mr. Flocken, Chairman of WIM WG, gave an update on the development of the WIM draft code and clarified that its scope is strictly for screening purposes.

OWM encourages further development of the draft code by the Weigh-In-Motion WG and offered the following feedback on the first draft:

1. To ensure that test procedures are applied uniformly, the WG may want to consider including in the draft code procedures for establishing the reference weights of axle loads, axle-group loads, and gross vehicle weight. The WG may also want to consider specifying the types of scales considered acceptable for use in establishing such test loads and their acceptable degree of accuracy. Currently, Table T.3.1. of the draft code specifies tolerances for axle load, axle group load, and gross vehicle weight. It also specifies that these tolerances be based on a percentage of the applied test load. In order to apply these tolerances, test loads of known value for axle load, axle-group load, and gross vehicle weight need to be established in advance of dynamic testing of a WIM system using a reference scale suitable for making such determinations. Additionally, in accordance with NIST Handbook 44, Appendix A – Fundamental Considerations, the error and uncertainty of the test loads, if used without correction, must be less than one-third the applicable tolerance. The draft code does not provide an indication of the types of scales considered acceptable for making such reference weight determinations (e.g., vehicle, axle-load), or the procedures that are to be followed when using those scales to establish the reference weights. OWM notes that the accuracy of the reference scale used for determining gross vehicle weight seems to be adequately addressed in paragraph N.1.3. Reference Scale, which requires each reference vehicle to be weighed on a static scale meeting NIST Handbook 44 maintenance tolerances.
2. The WG may also want to consider including in the draft code specific requirements applicable to the design, installation, and maintenance of the approach and exit aprons of the weigh sensor(s) of a WIM system. OWM questions whether or not it's possible to obtain accurate and repeatable axle-load, axle-group-load, and gross vehicle weight determinations from vehicle WIM systems without including such requirements. Such requirements are needed to filter out inconsistent forces such as the following:
 - “Wheel hop” (or bounce) causes undesirable accelerated vertical forces to be applied to the weigh sensor(s) of a WIM system as vehicles to be weighed in motion pass over them. Such undesirable forces result when the tires of a vehicle to be weighed in motion pass over an irregular pavement surface on either side of the weigh sensor(s).
 - “Force transfer” is the transfer of applied force from one part of a vehicle being weighed in motion to another part. Such transfer of forces occur, for example, when individual axles or tandem axles of a vehicle are weighed individually and are not in the same plane (i.e., the vehicle being weighed is not level).

During development of the draft code, the WIM WG agreed not to include specific requirements for aprons in advance of and beyond the load sensor(s), but rather, agreed to include the following language in paragraph UR.2. User Location Conditions and Maintenance to deal with this issue: “The system shall be installed and maintained as defined in the manufacturer’s recommendation.” While the draft code does include a user requirement intended to address this issue, the draft language alone is not sufficient enough to adequately address this important aspect of a vehicle WIM installation. Based on expert analysis, OWM understands that minimum requirements for apron smoothness, slope, etc. are needed in order to achieve necessary levels of accuracy. Both ASTM E-1318-09 and OIML R 134 include requirements that address the area leading to and from the sensor(s) of a WIM system. For example, the ASTM standard includes requirements for horizontal and longitudinal alignment, cross slope, surface smoothness, etc.

3. NIST, OWM suggests that the WIM WG revisit the idea of including in the draft code additional accuracy classes for WIM's capable of achieving greater accuracy levels. During the most recent WIM WG

meeting, some manufacturers of WIM equipment indicated that their equipment could meet a 6 % gross vehicle weight tolerance, which is significantly less than the 10 % currently specified in the draft code. The WG then considered whether to include different accuracy classes and specify corresponding tolerances for those accuracy classes in the draft code. However, the WG ultimately agreed to a single accuracy class and set of tolerances for the following reasons:

- The WG felt it was more expedient to simply specify a single accuracy class and set the limit of accuracy for that classification at the lowest end of what it considered an acceptable level of accuracy given the application of the device, and
- The WG agreed that the tasks performed by a WIM system, whether that WIM system is a “virtual weigh station” or one installed in a ramp at a more permanent site (e.g., a “weigh station” along an interstate highway) is the same.

NIST, OWM noted that tiered accuracy classes are already established in both ASTM E 1318-09 and OIML R 134. History has proven that it is better to establish a framework of tolerances around the various performance capabilities of equipment available in the marketplace early on in the development of the code, rather than designing the code around systems that provide lowest accuracy and then trying to change the code later.

In early discussions with representatives from FHWA, it was stated that one of the FHWA’s main goals for developing the draft code was to improve the accuracy and reliability of WIM systems in order to reduce the number of compliant commercial vehicles (i.e., those within legal load limits), being directed to static scales, which slows the transportation of freight. OWM recognizes the additional work that would be required by the WIM WG if it were to decide to include additional accuracy classes, but by doing so, it would benefit many (e.g., transportation industry, consumers, etc.) and improve the chances of the FHWA achieving one of its primary goals.

Mr. Dan Middleton, (Texas A&M University) WIM Project Task Manager, speaking on behalf of the U.S. FHWA, voiced support for the item by stating that the new code would improve consistency and legal credibility in the courts. He indicated that the United States does not have enough resources to adequately enforce highway weight requirements. Use and recognition of WIM standards in NIST Handbook 44 will allow better use of enforcement resources. In providing further evidence of the need for the code, he noted that currently less than one percent of vehicles directed to a static scale after being sorted on a WIM System are noncompliant.

Mr. Steve Langford (Cardinal Scale Manufacturing Company) commented that Cardinal Scale Manufacturing Company manufactures a series of WIM scales and encouraged further development of the draft code. He indicated that tiered accuracy classes are not important, nor needed in the code, at this time. The purpose of the WIM is to identify vehicles for enforcement; this is contrary to the application of OIML R 134, which is intended for WIM systems used in trade. ASTM 1318 provides different accuracy classes, but only one of which corresponds with the application of the draft code.

Mr. Tim Chesser (Arkansas) recommended a statement be included in the Application Section of the draft code clarifying that the code is intended for screening/sorting purposes only. *NIST Technical Advisor’s note: It is believed that paragraph A.1. of the draft code already addresses Mr. Chesser’s concern. Paragraph A.1. General. specifies that the code applies to systems used to weigh vehicles, while in motion, for the purpose of screening or sorting the vehicles based on vehicle weight to determine if a static weight is necessary.*

Ms. Julie Quinn (Minnesota) supported maintaining the “Information” status of the item and encouraged the WG to move quickly to finalize completion of the draft code.

Mr. Flocken expressed his appreciation for the comments received and indicated that he would forward them, along with OWM’s feedback, to the WG for consideration.

There were two positions posted on the NCWM 2013 Online Position Forum; both of which supported the proposal.

It is the Committee's understanding that Mr. Flocken will share OWM's suggestions with members of the WIM WG prior to their next meeting and the WG will consider whether or not additional revisions to the draft code are necessary prior to proposing the code to the NCWM for adoption.

321 BELT-CONVEYOR SCALE SYSTEMS

321-1 VC UR.1.2. Conveyor Installation

(This item was adopted.)

Source:

USNWG Belt-Conveyor Scales (2013)

Purpose:

Remove the current restrictions on minimum and maximum belt lengths.

Item Under Consideration:

Delete subparagraph UR.1.2.(h) of UR.1.2. Conveyor Installation and re-letter subsequent subparagraphs as follows:

UR.1.2. Conveyor Installation.

- (a) **Installation - General.** – A belt-conveyor scale shall be so installed that neither its performance nor operation will be adversely affected by any characteristic of the installation, including but not limited to, the foundation, supports, covers, or any other equipment.

(Amended 2002)

- (g) **Tripper and Movable Pulleys.** – There shall be no tripper or movable head pulleys in the conveyor.

~~(h) **Conveyor Length.** – The conveyor shall be no longer than 300 m (1000 ft) nor shorter than 12 m (40 ft) from head to tail pulley.~~
~~[Nonretroactive as of January 1, 1986]~~

- (ih) **Conveyor Orientation.** – The conveyor may be horizontal or inclined, but, if inclined, the angle shall be such that slippage of material along the belt does not occur.

- (ji) **Conveyor Stringers.** – Conveyor stringers at the scale and for not less than 6 m (20 ft) before and beyond the scale shall be continuous or securely joined and of sufficient size and so supported as to eliminate relative deflection between the scale and adjacent idlers when under load. The conveyor stringers should be so designed that the deflection between any two adjacent idlers within the weigh area does not exceed 0.6 mm (0.025 in) under load.

- (nm) **Belt Alignment.** – The belt shall not extend beyond the edge of the outermost roller of any carry side (top) roller in any area of the conveyor nor touch the conveyor structure on the return (bottom) side of the conveyor.

(Amended 1998 and 2008)

(Amended 2002, ~~and~~ 2012, and 2013)

Background/Discussion:

Belt-conveyor scale manufacturers participating in the USNWG on BCS have reported increased demand for shorter conveyor systems in commercial applications. The minimum conveyor length specified in sub-paragraph UR.1.2.(h) and other requirements in the Belt-Conveyor Scales Systems Code that set minimum spacing requirements between components on a belt-conveyor scale system will not currently permit shorter systems. During their February 2012 meeting, the USNWG on BCS concluded that the limit of 40 ft for a conveyor is unrealistic due to the spacing required between components and that this requirement is too prescriptive. In addition, the USNWG agreed that limiting the conveyor length to 1000 ft would be self-regulating to some extent, in that calibration and testing that incorporates the use of whole/full revolutions of the belt would be excessively time consuming. The USNWG also agreed that the performance of the weighing device should be evaluated without regard to conveyor length and that, if there are designs of devices that support acceptable performance using conveyors outside the limits of this requirement, the requirement should be stricken. As an initial step towards removing language in the Belt-Conveyor Scale Systems Code that is prohibitive of shorter belt conveyor system weigh-belts, the USNWG recommends that subparagraph UR.1.2.(h) be deleted. The USNWG plans to continue to develop further proposals to amend additional requirements within the BCS Code to recognize shorter belt-conveyor scale systems.

The elimination of UR.1.2.(h) will further align U.S. standards with the international requirement OIML R 50 Continuous totalizing automatic weighing instruments (belt weighers) in that OIML R 50 does not contain minimum or maximum requirements relating to conveyor length.

During their fall 2012 meetings, all of the Regional Associations supported the proposal as written and recommended it be forwarded to the NCWM for vote. Mr. Bill Ripka (Thermo-Fisher Scientific), speaking on behalf of Thermo-Fisher Scientific and the USNWG on Belt-Conveyor Scales at the WWMA meeting, supported the proposal to eliminate UR.1.2.(h). He stated that the minimum (40 ft) restricts placement of the scale and that such a restriction is not consistent with other codes in NIST Handbook 44. He indicated that the USNWG on BCS is working on a proposal to allow smaller feeders. He has found that excessive belt scale lengths are self-regulating due to the difficulty in testing them. Additionally, weights and measures jurisdictions are easily granting exceptions to the limits currently in NIST Handbook 44, so there is no need for these restrictions.

2013 NCWM Interim Meeting Open Hearings: Mr. Ripka, speaking on behalf of Thermo-Fisher Scientific and as Chairman of the USNWG on BCS, reiterated the comments he provided during the fall 2012 WWMA Annual Meeting.

NIST OWM stated that calibration and testing of belt-conveyor scale systems with excessively long conveyors could be problematic primarily due to the time needed to complete full revolutions of the conveyor belt. Belt-conveyor scale systems using excessively short conveyor belts may also present challenges in designing those systems to account for difficulties including the location and placement of conveyor components and maintaining proper belt tension during operation. OWM does not believe that it is appropriate for NIST Handbook 44 Belt-Conveyor Scale Systems Code to include a requirement that prescribes limitations on the maximum and minimum length of conveyors associated with belt-conveyor scales if it can be demonstrated that conveyors of a length outside these limits are capable of complying with all applicable performance requirements.

OWM does not anticipate any negative effect with the removal of requirement UR.1.2.(h) Conveyor Length as proposed and acknowledged the point that the elimination of this sub-paragraph serves to further harmonize NIST Handbook 44 Belt-Conveyor Scale Systems Code with OIML R 50.

The Committee agreed with the justification provided by USNWG on BCS and the comments received during the Open Hearings in support of this item and agreed to recommend the item for a vote.

2013 NCWM Annual Meeting Open Hearings: The Committee heard comments in support of the item from Mr. Ripka, speaking on behalf of the USNWG on BCS systems and Mr. Flocken, speaking on behalf of the SMA. Mr. Ripka commented that weights and measures officials should evaluate belt-conveyor scale system performance and not prescribe design criteria. OWM reiterated the comments it provided during the 2013 NCWM Interim Meeting.

There was one position posted on the NCWM 2013 Online Position Forum in support of the proposal.

The Committee recommended the item be presented for Vote as proposed.

321-2 VC Appendix D – Definitions: Belt Revolution, Belt Load, Integrator, Loading Point, and Master Weight Totalizer

(This item was adopted.)

Source:

U.S. National Work Group on Belt-Conveyor Scales (USNWG BCS) (2013)

Purpose:

Provide clarity of meaning for the use of terms in the Belt-Conveyor Scales Code to avoid confusion or misuse.

Item Under Consideration:

Add three new definitions and amend two existing definitions in Appendix D – Definitions associated with the Belt-Conveyor Scale Systems Code as follows:

belt load. – The weight of the material carried by the conveyor belt, expressed in terms of weight units per unit of length (e.g., pounds per foot, kilograms per meter. Also called Belt Loading.[2.21]

belt revolution. – The amount of conveyor belt movement or travel that is equivalent to the total length of the conveyor belt. Also referred to as “belt circuit.”[2.21]

integrator. – A device used with a belt-conveyor scale that combines conveyor belt load (e.g., lb/ft) and belt travel (e.g., feet) to produce a total weight of material passing over the belt-conveyor scale. An integrator may be a separate, detached mechanism or may be a component within a totalizing device. (Also see “master weight totalizer.”)[2.21]

loading point. – ~~The A~~ location ~~at which material to be conveyed is applied to the conveyor on a conveyor where the material is received by the belt. The location of a hopper, chute, or the discharge of a pre-feed device used to supply material to a conveyor.~~[2.21]

master weight totalizer. – ~~An primary~~ indicating element used with a belt-conveyor scale ~~that incorporates the function of an integrator~~ to indicate the ~~totalized~~ weight of material ~~that was~~ passed over the scale. ~~The master weight totalizer is a primary indicating element of the belt-conveyor scale. (Also see “integrator.”)[2.21]~~

NIST Technical Advisor’s Note: During their February 2013 meeting, the USNWG BCS agreed to further modify the definition of “loading point” to better clarify the location of the loading point on a conveyor. The USNWG forwarded the following proposed definition to the S&T Committee to replace that shown above in Item Under Consideration:

loading point. – ~~The A~~ location ~~at which material to be conveyed is applied to the conveyor on a conveyor where the material is received by the belt. The location of the discharge from a hopper, chute or the discharge of a pre-feed device used to supply material to a conveyor.~~ [2.21]

Background/Discussion:

Certain terms and phrases are used in NIST Handbook 44 and in discussions related to belt-conveyor scale systems that have specific meanings within that context. The terms “belt revolution,” “belt load,” and “integrator” appear in various paragraphs throughout the Belt-Conveyor Scale Systems Code and yet, are not currently defined in NIST Handbook 44. The terms “master weight totalizer” and “loading point” are currently defined in Appendix D. “Master weight totalizer” is frequently used interchangeably with the term “integrator.” The proposed amendment to this definition is intended to distinguish between these two terms while recognizing the interrelated functions of:

1) the integration of belt travel and belt loading and 2) the totalization and display of weight passing over the weighing device. The changes proposed to the definition of “loading point” are intended to improve understanding.

During the fall 2012 Regional Weights and Measures Association Meetings, each of the regions supported the proposal and recommended it be forwarded to NCWM as a Voting Item. Based upon meeting reports received from the various regions, there were few comments made during the meetings regarding the item, with most regions acknowledging their support of the item based on its development and recommendation by the USNWG on BCS. Mr. Bill Ripka (Thermo Fischer Scientific) commented during the WWMA meeting that he supported the addition of the new definitions of “belt revolution,” “belt load,” and “integrator” and the proposed changes to “loading point” and “master weight totalizer.” Mr. Ripka said that he believed it made sense to have a description in NIST Handbook 44 of what these terms mean.

2013 NCWM Interim Meeting Open Hearings: Mr. Ripka, speaking on behalf of the USNWG on BCS, commented that the USNWG had reviewed and agreed on the definitions of the terms in the proposal and believed they were necessary to include in NIST Handbook 44. The USNWG believes that these definitions will improve understanding of these terms and provide more consistent application of requirements in the NIST Handbook 44 Belt-Conveyor Scale Systems Code where these terms are used.

NIST OWM noted that the definition of “loading point” already existed in Appendix D of NIST Handbook 44 and should not be presented as a new definition, but instead, as an amended definition in the “Item Under Consideration.” OWM provided the Committee an amended version of the definition appearing in Appendix D of NIST Handbook 44 for consideration, which is the same definition included in the original proposal, except that it includes revisions shown in **bold face print** by ~~striking out~~ information to be deleted and underlining information to be added to the current definition in NIST Handbook 44.

OWM acknowledged the merits of this proposal, to include providing three new definitions for terms that are used specifically in association with belt-conveyor scale systems as well as the proposed amendments of the existing definitions for “master weight totalizer” and “loading point.” These definitions clarify the meaning of these terms and will assist in the interpretation of the NIST Handbook 44 Belt-Conveyor Scale Systems Code.

The Committee agreed with comments received during the Open Hearings in support of the proposed definitions. The Committee agreed that the proposed definition of “loading point” should be presented as a modification to the existing definition in NIST Handbook 44 and modified the proposal accordingly as shown in the Item Under Consideration.

Based on the support for these changes, the Committee agreed to designate this as a Voting Item.

2013 NCWM Annual Meeting Open Hearings: The Committee replaced the definition of “loading point” that was originally submitted as part of the proposal, with the modified version proposed by the USNWG on BCS following their February 2013 meeting. The modified version is included above in Item Under Consideration as part of the NIST Technical Advisor’s note.

OWM reiterated the comments it made during the 2013 NCWM Interim Meeting and also commented that the changes to the definition of “loading point” proposed by the USNWG on BCS improve the definition of that term by better clarifying the location of each loading point on a BCS system.

The Committee also heard comments in support of the item from Mr. Ripka, who indicated that the information provided by the definitions will be very helpful in understanding terms that are not a part of everyone’s vocabulary. Mr. Ripka also encouraged other groups to review definitions pertinent to their expertise and make recommendations for updates as appropriate.

There was one position posted on the NCWM 2013 Online Position Forum in support of the proposal.

The Committee modified the definition of “loading point” as recommended by the USNWG on BCS and presented the item for a vote as shown in the Item Under Consideration above.

330 LIQUID MEASURING DEVICES

330-1 W S.1.6.4.2 (a) Product Identity and UR.3.2. Unit Price and Product Identity

(This item was withdrawn)

Source:

Missouri Department of Agriculture (2013)

Purpose:

Reduce the potential for mis-fueling consumer vehicles.

Item Under Consideration:

The Committee considered the following proposal to amend paragraphs S.1.6.4.2. and UR.3.2. However, as described in the “Background/Discussion” section, the Committee decided to Withdraw this item from its agenda.

S.1.6.4.2. Product Identity.

- (a) A device shall be able to conspicuously display on each side the identity of the product being dispensed.
- (b) A device designed to dispense more than one grade, brand, blend, or mixture of product also shall be able to display on each side the identity of the grade, brand, blend, or mixture being dispensed.
- (c) The term “Gasoline”, “E15Gasoline”, “E85”, or “Flex-Fuel” shall be conspicuously displayed on the dispenser nozzle(s). This subsection applies only to spark-ignition engine fuel dispensers.

(Amended 20XX)

UR.3.2. Unit Price and Product Identity.

- (a) The following information shall be conspicuously displayed or posted on the face of a retail dispenser used in direct sale:
 - (1) except for dispensers used exclusively for fleet sales, other price contract sales, and truck refueling (e.g., truck stop dispensers used only to refuel trucks), all of the unit prices at which the product is offered for sale; and
 - (2) in the case of a computing type or money-operated type, the unit price at which the dispenser is set to compute.

Provided that the dispenser complies with S.1.6.4.1. Display of Unit Price, it is not necessary that all the unit prices for all grades, brands, blends, or mixtures be simultaneously displayed or posted.

- (b) The following information shall be conspicuously displayed or posted on each side of a retail dispenser used in direct sale:
 - (1) the identity of the product in descriptive commercial terms; and
 - (2) the identity of the grade, brand, blend, or mixture that a multi-product dispenser is set to deliver.

(c) The term “Gasoline”, “E15Gasoline”, “E85”, or “Flex-Fuel” shall be conspicuously displayed on the dispenser nozzle(s). This subsection applies only to spark-ignition engine fuel dispensers.

(Amended 1972, 1983, 1987, 1989, 1992, ~~and~~ 1993, and 20XX)

Background/Discussion:

The level of confusion for consumers fueling vehicles continues to grow with the introduction of new fuels in the marketplace. The proposed changes are intended to ensure proper delivery of the selected product and to reduce the potential of mis-fueling vehicles. Missouri and other states have received complaints from consumers who have fueled their vehicles with inappropriate products. At this time, practically all gasoline dispensers nationwide do not comply with paragraph UR.3.2. or S.1.6.4.2.(a) as they do not display the product identity (i.e., gasoline).

2012 CWMA Interim Meeting: The CWMA proposed that the item be designated as an Informational Item. The CWMA did not support the proposed change to paragraph S.1.6.4.2., but did support the change to UR.3.2. The CWMA recommended review of the item by the NCWM FALS.

2012 WWMA Annual Meeting: Mr. Mahesh Albuquerque (Colorado) opposed this item because it is burdensome and adequate labeling requirements already exist. He noted that consumers need to take ownership and read the labeling to avoid mis-fueling. Mr. Gordon Johnson (Gilbarco) opposed this item because it doesn't effectively solve the problem. He believes this should not be a specification, but rather a user requirement because 90 % of his company's dispensers are sold without hoses and nozzles. He questioned how this requirement would even be implemented. Mr. Ron Hassmeyer (Alameda County, California) opposed the item and stated that labeling in S.1.6.4.2. Product Identity is adequate to require a product description. He also questioned how this item would apply to a multi-product dispenser. Mr. Hassmeyer believed this would be an undue burden to the device owner. Mr. Doug Deiman (Alaska) recommended this item be Withdrawn, noting that it is too much of a burden on gas pump owners. Ms. Kristin Macey (California) opposed this item and recommended Withdrawal. The WWMA recognized the lack of support for this proposal and agreed that the product identity section adequately addresses this issue. Additionally, the WWMA did not understand the submitter's comment that practically all gasoline dispensers nationwide do not comply with paragraphs UR.3.2. or S.1.6.4.2.(a). The WWMA did not forward the item to NCWM.

2012 NEWMA Interim Meeting: Members questioned whether this item should be a weights and measures responsibility. NEWMA believes that this item should be addressed by FALS.

2012 SWMA Annual Meeting: Mr. Matt Curran (Florida) provided comments on behalf of Mr. Ron Hayes (Missouri). Mr. Hayes noted that the intent of the proposal was not to increase labeling requirements, but to provide an additional point at which a consumer would be informed of the product identity. He had more interest in establishing a user requirement than a specification. Mr. Curran noted that there are stations in Florida that dispense E85 where the attendant specifically asks the consumer whether or not the vehicle can accommodate the fuel. Mr. Steve Benjamin (North Carolina) questioned how the requirement would be applied on a dispenser with a single hose used to dispense multiple products. He noted that the proposal seems to be just another variation on the proposed color-coding requirement considered in the past. Mr. Ed Coleman (Tennessee) supported the proposal, pointing out that more labeling on the dispenser may result in having too much information on the dispenser that no one reads. However, on nozzles, he believes that the labeling would have more visibility. Mr. Johnson opposed the item. Mr. Tim Chesser (Arkansas) opposed the item, noting concern about the impact of requiring new labeling on all existing nozzles. Mr. Bill Studzinski (General Motors) expressed appreciation for the effort to further clarify product identity, but opposed the proposal, noting that there is already a requirement for marking product identity in NIST Handbook 44. He echoed concerns about how the requirement would apply to single hose dispensers with multiple products. The majority of comments received by the SWMA were in opposition to the proposal. The SWMA appreciated the desire to improve consumer understanding but believed the proposal would not fully address mis-fueling incidents. Noting that there were too many questions about how the language would be applied, particularly with single-hose, multi product dispensers, SWMA did not forward the item to NCWM.

2013 NCWM Interim Meeting: Mr. John Albert (Missouri) gave a presentation which illustrated the types of complaints that Missouri routinely receives. He indicated that this problem has been in existence for a long time,

noting that customers associate the color “green” with diesel dispensers and frequently mistake dispensers with green gasoline nozzles for diesel dispensers. Mr. Albert reported that they have received thousands of complaints on this subject and they find that customers frequently make fueling mistakes because their attention is distracted by things such as discount information, station traffic, and other signage on the dispenser, not to mention personal distractions. He noted that octane stickers are not sufficient by themselves to alert distracted customers that the dispenser is dispensing gasoline and not diesel. Mr. Tim Columbus (Steptoe and Johnson), speaking on behalf of the National Association of Convenience Store Operators, expressed concern about the proposal, noting that this affects only a small percentage of customers and many of the customers who mis-fuel their vehicles admit they are not paying attention. He also commented that octane stickers on gasoline dispensers are adequate to alert consumers that the product is gasoline. Mr. Johnson reiterated comments made at the 2012 WWMA Annual Meeting, noting that about 95 % of Gilbarco’s customers do not purchase hoses and nozzles with new dispensers, preferring to put their own on the equipment upon installation. Gilbarco believes that, if the Committee decides to move forward with the proposal, it should be addressed through the addition of a user requirement.

Mr. Hayes, speaking as Chairman of FALS, noted that FALS provided the Committee with alternative language. The alternative proposal eliminates the proposed addition of S.1.6.4.2.(c) and replaces the proposed UR.3.2.(c) with the following:

(c) The term “Gasoline”, “E15”, “E15 & Gasoline” for multiple product dispenser with single nozzle, “E85”, or “Flex-Fuel” shall be conspicuously displayed on the dispenser nozzle(s). This subsection applies only to spark-ignition engine fuel dispensers. This section satisfies subsection UR.3.2.(b)(1) requirement.

During its work session, the Committee clarified with Mr. Albert that Missouri believes that the current language in UR.3.2.(b)(1) provides means to require clear identification of the product identity; however, the proposed changes would promote uniformity in the use of terminology, not only for diesel dispensers, but also other fuels and, hopefully, reduce incidents of mis-fueling. Mr. Albert noted that Missouri is not able to enforce the use of specific colors to identify products without changes to NIST Handbooks 44 and 130.

After reviewing the original and alternate proposals and considering the comments received during the Open Hearings, the Committee expressed concerns about the extent of support for the proposal. The Committee is concerned about the potential burden on stations to modify current equipment, particularly when there are questions about whether or not the proposed changes would significantly reduce mis-fueling incidents. Provided a dispenser is clearly labeled with the product identity as required by UR.3.2., the Committee believes that the customer must accept some responsibility to follow instructions and signage during the transaction. While the Committee appreciates the concerns that have been raised by Missouri, the Committee agreed that the proposed marking requirements would not resolve all mis-fueling problems and the Committee does not believe there is a consensus to support the proposal. Consequently, the Committee decided to Withdraw the item.

At their spring 2013 Annual Meetings, NEWMA and the CWMA concurred with the Withdrawal of this item. The Committee received no further comments on the item during its 2013 Annual Meeting Open Hearings.

330-2 VC Table T.2. Accuracy Classes and Tolerances for Liquid Measuring Devices

(This item was adopted.)

Source:

NIST Office of Weights and Measures (2013)

Purpose:

Resolve inconsistencies in the temperature ranges defined for Heated Products among NIST Handbook 44 Liquid-Measuring Devices, Vehicle-Tank Meters, and Mass Flow Meters Codes.

Item Under Consideration:

Amend Table T.2. follows:

Table T.2. Accuracy Classes and Tolerances for Liquid Measuring Devices Covered in NIST Handbook 44, Section 3.30				
Accuracy Class	Application	Acceptance Tolerance	Maintenance Tolerance	Special Test Tolerance¹
0.3	<ul style="list-style-type: none"> - Petroleum products delivered from large capacity (flow rates greater than 115 L/min or 30 gpm)** devices, including motor-fuel devices - Heated products (other than asphalt) at or temperatures greater than 50 °C (122 °F) - Asphalt at temperatures equal to or below a temperature of 50 °C (122 °F) - All other liquids not shown in the table where the typical delivery is over 200 L (50 gal) 	0.2 %	0.3 %	0.5 %
0.3A	<ul style="list-style-type: none"> - Asphalt at temperatures greater than 50 °C (122 °F) 	0.3 %	0.3 %	0.5 %
0.5*	<ul style="list-style-type: none"> - Petroleum products delivered from small capacity (at 4 L/min (1 gpm) through 115 L/min or 30 gpm)** motor-fuel devices - Agri-chemical liquids - All other applications not shown in the table where the typical delivery is ≤ 200 L (50 gal) 	0.3 %	0.5 %	0.5 %
1.1	<ul style="list-style-type: none"> - Petroleum products and other normal liquids from devices with flow rates** less than 1 gpm. - Devices designed to deliver less than 1 gal 	0.75 %	1.0 %	1.25 %
<p>* For test drafts ≤ 40 L or 10 gal, the tolerances specified for Accuracy Class 0.5 in the table above do not apply. For these test drafts, the following applies:</p> <p>(a) Maintenance tolerances on normal and special tests shall be 20 mL plus 4 mL per indicated liter or 1 in³ plus 1 in³ per indicated gallon.</p> <p>(b) Acceptance tolerances on normal and special tests shall be one-half the maintenance tolerance values.</p> <p>¹ Special test tolerances are not applicable to retail motor fuel dispensers.</p> <p>** Flow rate refers to designed or marked maximum flow rate.</p>				

(Added 2002) (Amended 2006 **and 2013**)

Background/Discussion:

This item was initiated as a result of discussions at an NTEP measuring labs meeting and forwarded to the Measuring Sector for review in 2011. In reviewing criteria for heated products during discussions at the 2011 annual NTEP Laboratory Meeting, the Measuring Laboratories noted inconsistencies in the way that heated products are referenced in the LMD, VTM, and MFM Codes.

The differentiation between “heated” and “non-heated” products first appeared in NIST Handbook 44 in 2000 as a result of a proposal adopted by the NCWM in 1999 to expand the tolerances applicable to meters use to measure asphalt above 50 °C (see S&T Committee Items 330-6 and 337-4 in the 1999 NCWM S&T Committee Final Report for details). This reference was refined by the Committee in 2001 when changes were adopted to clarify the application of tolerances to asphalt at 50 °C in the LMD and MFM Codes. When the LMD and VTM Codes were modified in 2003 and 2004 to adopt an accuracy class table to mirror the Mass Flow Meter (MFM) Code, inconsistencies first appeared in the way that heated products were referenced among the codes.

This proposal and similar proposals elsewhere in the Committee's agenda, suggest changes to correct these inconsistencies. A summary of the proposals is listed below.

Section: 3.30. Liquid-Measuring Devices; Table T.2. (S&T Item 330-2)

Section: 3.31. Vehicle-Tank Meters; Table 1. (S&T Item 331-1)

Section: 3.37. Mass Flow Meters; Table T.2. (S&T Item 337-3)

NIST OWM notes that there also may be a need to address hot water meters (for which the American Water Works Association (AWWA) defines a boundary temperature of 90 °F) in NIST Handbook 44.

The proposed changes in these items take into account corresponding references to heated products in NCWM Publication 14, including the "Product Families Table" in Technical Policy C and past discussions at meetings of the NTEP Measuring Sector. Revisions are also proposed to ensure appropriate references to both Fahrenheit and Celsius temperatures.

NEWMA and SWMA supported moving this item forward as a Voting Item at their 2012 Annual Meetings. The SWMA also recommended that this item be consolidated with correlating items in the VTM and MFM during the voting process to help ensure consistency among these codes.

2013 NCWM Interim Meeting: The Committee received comments in writing from NIST OWM reiterating the origin of the proposal and noting that the goal of the proposed changes is to improve consistency in references to heated products among the codes. OWM noted that this item is largely housekeeping and is intended (along with S&T Agenda Items 331-1 and 337-3) to clarify the application of tolerances to different types of heated products and to ensure consistency across several metering codes. The MFM Code does not include any specified temperature threshold that would define "heated products" as is provided in both the LMD and VTM Codes. Since MFMs could be used in the same applications as other meter types covered by the LMD and VTM Codes, it would be logical for the temperature threshold to be the same. Additionally, the current formatting of references to temperature thresholds is inconsistent among LMD, VTM, and MFM Codes. The Committee also heard comments from Mr. Michael Keilty (Endress and Hauser) who agreed with NIST OWM's comments and further suggested that discussion be taken simultaneously on this item and Items 331-1 and 337-3 for expediency. Hearing no opposition to the proposed changes, the Committee agreed to move this item forward for a vote.

2013 spring NEWMA and CWMA Annual Meetings: NEWMA and the CWMA supported the designation of this item as a Voting Item and agreed with the need to resolve current inconsistencies. Three government representatives indicated support for this item on the NCWM Online Position Forum with no additional comments.

2013 NCWM Annual Meeting: The Committee took comments on this item simultaneously with Items 331-1 and 337-3. The Committee heard no comments in opposition to these items. Mr. Dmitri Karimov (Liquid Controls Corporation, LLC) stated that this is a good housekeeping item, and he supported considering this item in conjunction with related items in the VTM Code and the MFMs Code. NIST OWM reiterated its comments from the 2013 Interim Meeting and suggested voting on Items 330-2, 331-1, and 337-3 together to avoid any inconsistencies.

330-3 I N.4.2.4. Wholesale Devices

(The status of this item was changed from Voting to Informational.)

Source:

Flint Hills Resources (2013)

Purpose:

To better align wholesale meter testing with current testing procedures, measuring practices and technology changes while maintaining the integrity of the special test.

Item Under Consideration:

Amend paragraph N.4.2.4. as follows:

N.4.2.4. Wholesale Devices. – “Special” tests shall be made to develop the operating characteristics of a measuring system and any special associated or attached elements and accessories.

N.4.2.4.1. Special Test, Type Evaluation. – “Special” tests shall **be made during type evaluation** ~~include a test~~ at the slower of the following rates:

- (a) 20 % of the marked maximum discharge rate; or
- (b) The minimum discharge rate marked on the device.

Add a new paragraph N.4.2.4.2. as follows:

N.4.2.4.2. Special Test, Field Evaluation. – “Special” tests shall be made during field tests at or near the minimum discharge flow rate developed under the conditions of installation, but not less than the minimum discharge rate marked on the device.

Background/Discussion:

This proposal is intended to clarify that conducting a slow flow test to the marked minimum discharge rate is required for type evaluation and testing to the minimum discharge flow rate developed under the conditions of installation for routine field inspections is appropriate. It would:

1. Remove the rigidity of the current language and provide for flexibility and efficiency while maintaining the requirement to test at different flow rates to determine the accuracy of a measuring system;
2. Differentiate between testing for type evaluation and field verification;
3. Reflect changes in field testing procedures, technology, and industry practices; and
4. Improve meter performance by establishing a meter factor for the slowest preset flow rate.

The current language is very rigid and does not take field installation conditions into consideration. It may not be possible or practicable to achieve the marked minimum discharge rate during field tests without changes to upstream equipment (valves, pumps, etc.), changing the flow computer programmed presets, or changing the idling of other fueling bays during testing.

The code does not allow for any deviation from the “shall” test at the marked minimum discharge rate. Current loading rack systems generally do not have a discharge nozzle or other physical means downstream of the meter to control or restrict the flow rate. Today, most rely on pumps and valves upstream of the meter and preprogrammed flow rates for specific products with an assigned meter factor for each flow rate and product. The proposed change would still allow for testing at the marked minimum discharge rate when there is a discharge nozzle or other physical means in use downstream of the meter to restrict flow, but would recognize the need to vary from the marked minimum discharge rate for systems not so equipped.

The submitter notes that it is more productive to verify that the system is operating properly when used in its intended manner and set-up rather than alter the system for test-purposes and then return it to its “as-used condition.” Adjusting the system to flow at the marked minimum discharge rate by making changes to the system when that flow rate is not used introduces variables into the system not normally seen and adds little to no value.

Even if the system can achieve the marked minimum discharge rate (for example, through the use of a discharge nozzle), it is not always practical or possible to hit it exactly when testing. The variables involved with proving while multiple bays are operating at a loading rack can make achieving the target flow rate difficult. It is not really necessary to test exactly at the marked minimum flow rate to develop the operating characteristics of a meter.

However, NIST Handbook 44 offers no room for deviation. Today, a wholesale meter tested “near,” but not exactly “at,” the marked minimum discharge rate is not being tested in accordance with the requirements of NIST Handbook 44. This problem may never be an issue, but it might (the history regarding the change to NIST Handbook 44, Introduction section illustrates why the language in the handbook must match the application of it in the field). Amending the current language as proposed will remove this risk, however, slight.

In the LMD Code, retail motor-fuel devices with a marked minimum flow rate are tested “at or near the marked minimum flow rate,” but are not required to be tested at exactly the marked minimum. If this is acceptable for a retail motor-fuel dispenser, then it should be acceptable for a wholesale meter. The proposal would make testing more uniform and consistent among different but similar device types.

The purpose of this proposal is not to do away with a special test but to make the test more reasonable. The proposal would allow the integrity of the test process to be maintained while providing both industry technicians and weights and measures officials the flexibility to test the meter in a manner that is more reflective of actual field testing and device use. It is designed to test meters not at the *design* flow rate but at the flow rate at which they are actually used. It does not preclude a weights and measures inspector from testing at the marked minimum flow rate; it just removes the mandate to conduct it at that flow rate.

The submitter points out the following supporting arguments:

- The marked minimum and maximum discharge rates are design parameters, not operational parameters.
- The Mass Flow Meters Code does not require testing at the marked minimum discharge rate. It requires, at a minimum, that one test be conducted at the minimum flow rate of the installation.
- The principle of testing as used and not to the design parameters is present in other codes and testing. It exists for scales since scales are not required to be tested to their design parameters; they are only tested as set up and used. A scale may be rated at a capacity range of 100 000 lb to 200 000 lb and a scale division of 20 lb or 50 lb, but it will only be tested based on its conditions of installation regardless of how it could be used.
- NIST Handbook 44 does not require that a measuring system be tested at the marked maximum discharge rate because it recognizes the measuring system may not be able to achieve the marked maximum discharge rate due to the conditions of installation.
- There is no regulation requiring a meter to be able to discharge at its marked minimum discharge flow rate; the marked minimum discharge flow rate is a design parameter not a use requirement.
- Not all tests in the test notes section are required to be conducted in the field as is noted in NIST Handbook 44, Introduction, Section S. Using the handbook, which states, “Since some sections are designed to be applied to tests performed under laboratory conditions, it would be impractical or unrealistic to apply them to field tests. Not all tests described in the “Notes” section of the handbook are required to be performed in the field as an official test.” Based on this section, it could be argued that a “special” test is not even required; however, the submitter believes that the special test has value and is not seeking to eliminate the test entirely.

The proposal doesn’t specify the exact flow rate, but requires a test at the minimum flow rate based on the system and the establishment of a meter factor at that flow rate. The added flexibility and establishment of a meter factor during the test is important for both industry technicians and weights and measures officials.

The proposed change is similar to the recommended tests described in API Manual of Petroleum Measurement Standards (MPMS), Chapter 6.2. Loading Rack Metering Systems – “When using electronic presets with multiple flow rate configurations, the establishment of multiple meter factors may be required. This is particularly true when low flow start-up and shutdown sequences are employed to prevent system shock and static electricity generation (see API RP 2003).”

A potential argument in opposition to the proposal is that, even if the system is not being used at the marked minimum discharge rate at the time of test, it could be used later; thus, it is important to not only test as found, but as it could be used. While there is some merit to this argument, it is not consistently applied since many systems are tested as found, not as they *could be* used. There is also no incentive for a fuel terminal to not test their system as used. Further, the current practice is to set a calibration factor for all flow rates, so it is unlikely that the system would be changed after testing without additional testing and establishment of a calibration factor.

Based on comments received at its 2012 Interim Meeting, the CWMA amended the original proposal to reflect language that was applicable to field practices and current with technology. The language was also amended to maintain special tests as a requirement during type evaluation, but optional for other examinations. CWMA supported the item as amended and forwarded the item to NCWM; recommending it as a Voting Item. The proposal submitted by the CWMA is as follows:

N.4.2.4. Wholesale Devices. – “Special” tests shall be made **during type evaluation** to develop the operating characteristics of a measuring system and any special associated or attached elements and accessories. “Special” tests shall include a test at the slower of the following rates:

- (a) 20 % of the marked maximum discharge rate; or
- (b) The minimum discharge rate marked on the device.

N.4.2.5. Wholesale Devices; Other Tests. – **Other tests may be made during field tests at or near the minimum discharge flow rate developed under the conditions of installation for all wholesale devices.**

- (a) For devices equipped with electronic preset flow rates, tests may be conducted at any electronic preset flow rate used, including the slowest flow rate, when multiple flow rate configurations are used to deliver product.**
- (b) “Normal” applicable tolerances shall apply to tests conducted.**

U.R.3.6.4. Wholesale Devices; Electronic Preset Flow Rates – A meter factor shall be established for all electronic preset flow rates used to deliver product.

2013 NCWM Interim Meeting: The Committee heard comments from Mr. Ross Andersen (New York, retired) who suggested if the concern is that there is not enough flexibility in the reference to “20 % of the marked maximum,” the focus should be placed on modifying this reference rather than making other proposed changes. He provided alternative language for the Committee to consider. The Committee also received written and verbal comments from NIST, OWM noting that the proposed language would not consider any test conducted at lower flow rates to be “normal” tests and, therefore, such tests would be required to meet “normal” test tolerances.

OWM commented that it is important to verify the performance of a meter over the range of flow rates for which it is designed to operate. The “normal” test (as described in N.4.1. Normal Tests) combined with a “slow flow” test (as described in N.4.2.4. Wholesale Devices) allows an inspector or serviceperson to verify the performance of a meter over the range in which it is typically used under the conditions of its installation. For positive displacement meters with single point calibration, the results of both tests can be used to determine whether or not a particular meter is providing accurate measurement over the complete range of operating speeds associated with its installation and whether the meter is in good operating condition. Product discharge rates are affected by installation particulars (e.g., the diameter of the piping, pump speed), and these can be changed after installation, thus, affecting meter performance. For these reasons, OWM recommends the slow-flow test remain a required part of an official test as was originally intended by the original submitter of this item. As a general rule, OWM recommends that test procedures considered part of an official examination of a commercial weighing or measuring device not be made elective because, as such, they create the potential for inconsistent enforcement of legal requirements amongst weights and measures jurisdictions.

The proposed new paragraph N.4.2.5. Wholesale Devices; Other Tests allows for a test at the minimum discharge rate marked on the device but would have the effect of eliminating the application of the “Special Test” tolerance, which currently applies to the results of a test conducted at flow rates below a certain point. Since the test would no longer be considered a “Special Test,” basic tolerances (i.e., 0.3 % maintenance and 0.2 % acceptance) would apply and these tolerances are more stringent than the current “Special Test” tolerance of 0.5 % specified in NIST Handbook 44. OWM is concerned about the impact this change may have on existing in-service wholesale equipment that might currently be able to comply with the “Special Test” tolerance, but may not be able to comply if that tolerance were tightened. For example, in instances where the minimum discharge flow rate developed under the conditions of installation (i.e., the test condition specified in proposed new paragraph N.4.2.5. Wholesale Devices; Other Tests) for a wholesale device already in service, is equivalent to the lesser of the two rates specified in N.4.2.4., the flow rate for the test, whether applying proposed paragraph N.4.2.5. or existing paragraph N.4.2.4., would be the same, yet a more stringent tolerance would apply under proposed paragraph N.4.2.5.

An additional concern is that if the parameters of the test were changed from those currently specified in (a) and (b) of paragraph N.4.2.4. to the proposed “at or near the minimum discharge flow rate developed under the conditions of installation” the change would provide device owners the latitude of being able to try and extend the service life of a meter by compensating for badly worn or otherwise defective parts simply by increasing the minimum flow rate of product through it. Although such action would constitute a violation of G-UR.4.3. Use of Adjustments, it might be very difficult for officials to recognize and enforce.

For these reasons, OWM proposed alternate language (which combines elements of the original proposal and the CWMA alternative) as a means to provide more flexibility in conducting special tests, while retaining the original intent of the special test as a tool for verifying the condition of the meter.

OWM also commented that additional work is needed to develop minimum testing requirements for equipment with multi-point calibration capability to ensure consistency in inspection and testing of these systems.

Mr. Henry Oppermann (Weights and Measures Consulting) echoed OWM’s concerns regarding the need to conduct special tests as a means to assess the condition of the meter. He acknowledged that the current language in NIST Handbook 44 may not provide the same flexibility that is provided for other meter types (for which tests can be “at or near” the marked minimum); however, he expressed concern about backing off of a proper test for what appears to be primarily convenience. Mr. Constantine Cotsoradis (Flint Hills Resources) pointed out with many current systems, there frequently is not a way to restrict the flow rate. Mr. Richard Suiter (Richard Suiter Consulting) further commented that the location where flow is restricted (e.g., before vs. after the meter) during special tests can also affect the results of testing, and this should be considered in constructing the final language (and associated test procedures) for any proposed change.

Mr. Dmitri Karimov (Liquid Controls Corporation, LLC), speaking on behalf of the MMA, noted that the proposal has the effect of 1) providing some flexibility in establishing a flow rate near the marked minimum flow rate rather than at the minimum; 2) changing the tolerances that would apply to tests conducted at slower flow rates; and 3) specifying the establishment of meter factors for preset flow rates. Of these three facets, MMA only supports the first. He noted that some registers may use different types of calibration factors and addressing these variations in a single paragraph would be difficult. He further noted, if changes are made to the test conditions in the LMD Code, similar changes should be made to other measuring codes as needed to ensure consistency.

Ms. Julie Quinn (Minnesota) noted that Minnesota believes that it is necessary to conduct testing at every flow rate where the device is configured; however, the factors at these various points do not need to be different.

The Committee acknowledged the comments in support of maintaining the requirement for conducting special tests during routine field inspections, but modifying paragraph N.4.2.4. to provide for some flexibility in the rate at which a special test is conducted. In recognition of limitations which may prevent some systems from being tested exactly at the marked minimum flow rate, the Committee agreed that modification to the language to be more consistent with other measuring devices is appropriate. Based on the support heard for the language proposed by OWM with respect to N.4.2.4.1. Special Test, Type Evaluation and N.4.2.4.2. Special Tests, Field Evaluation, the Committee agreed to recommend this alternative language as shown in the Item Under Consideration above for a Vote.

In reviewing the remaining portion of the proposed changes, the Committee noted the considerable debate regarding the inclusion of the User Requirement regarding the establishment of meter factors for preset flow rates. Based on this opposition, the Committee considered splitting this proposal into two items: 1) to address the proposed changes to the Notes; and 2) to address the proposed changes to the User Requirements. However, there was very limited support for the proposed changes to the User Requirement. Thus, the Committee decided to eliminate the proposed paragraph U.R.3.6.4. Wholesale Devices; Electronic Preset Flow Rates from the Item Under Consideration.

2013 NEWMA and CWMA Annual Meetings: NEWMA and the CWMA supported the item as a Voting Item and commented that they believe the concerns stated by OWM and others at the NCWM Interim Meeting have been sufficiently addressed by the NCWM S&T Committee.

Two Government representatives indicated a position of support on the NCWM Online Position Forum. Another Government representative, Mr. Randy Jennings (Tennessee) indicated opposition to the proposal and, noting that the item appeared on only one regional weights and measures association agenda, expressed concern that the item requires more vetting. Mr. Jennings expressed concern about the phrase “developed under the conditions of the installation,” and noted that this may be interpreted to mean that, if a system can be installed to run at maximum flow rates other than “start-up” and “shut-down,” then an official cannot request that the system be “choked” to reduce the flow. He further commented that the reduced flow test has always been effective in detecting and diagnosing wear in the meter. He also noted that Tennessee has a valve on its prover that can be used to reduce the flow rate during a slow-flow test. Mr. Jennings proposed the following alternative changes to paragraph N.4.2.4.1. Special Test, Type Evaluation that would make the current requirement less restrictive; yet achieve a compromise to help all stakeholders:

N.4.2.4.1. Special Test, Type Evaluation. – “Special” tests shall include a test at the slower of the following rates:

- (a) **Approximately** 20 % of the marked maximum discharge rate; or
- (b) The **approximate** minimum discharge rate marked on the device.

During its Open Hearings at the 2013 Annual Meeting, the Committee received a proposed modification to the Item Under Consideration by the original submitter Mr. Cotsoradis. In addition to the other changes proposed in the Item Under Consideration, Mr. Cotsoradis proposed replacing the new paragraph N.4.2.4.2. with the following:

N.4.2.4.2. Special Test, Field Evaluation. – **A “Special” test shall be made during field tests at or near the minimum discharge flow rate developed under the conditions of installation, but not less than the minimum discharge rate marked on the device. Additional “Special” tests may be conducted at flow rates down to and including the maximum discharge rate marked on the device.**

Mr. Jennings supported this proposed modification by Mr. Cotsoradis.

Mr. Cotsoradis further noted that the current language in NIST Handbook 44 is very restrictive. Even in systems where the flow can be reduced, it is difficult to set the flow and maintain it at the target flow rate over the course of an entire test.

OWM noted that, according to the 1949 NCWM S&T Committee Report, requirements to conduct “Special Tests” were established in 1949. The report states that “Special” tests are not defined in detail except that such tests shall include tests at specified minimum discharge rates; other details of “Special” tests are left to the judgment of the official. The primary purpose of the “Special” test is to determine the condition of the meter and determine whether or not the user is maintaining the equipment in proper operating condition. As noted in comments during the 2013 Interim Meeting, the results of a “Special” test, conducted at a slow flow rate, when compared with the result of a “Normal” test can indicate the condition of the meter. In general, the greater the difference between meter errors observed for the “Normal” and “Special” test, the stronger the indication that the meter is in need of reconditioning. It is questionable whether or not two tests conducted at flow rates that are not appreciably different will provide adequate information about the condition of a meter. If the features of a particular installation do not

permit testing at the slower rates as currently required in paragraph N.4.2.4. Wholesale Devices, paragraph G-UR.4.4. Assistance in Testing Operations may be applied to facilitate a proper test. OWM also pointed out that when this requirement was first added the dominant meter technology was positive displacement meters. Since that time a number of different technologies have been developed and it may be necessary to reassess what minimum testing is necessary. OWM also noted that in training provided by NIST on testing of these systems, OWM recommends running tests at slightly above the targeted flow rate; this helps to prevent the flow rate from dropping below the meter's marked minimum flow rate and, thus, helps to ensure a fair test of the metering system. OWM also reiterated comments it made during the 2013 Interim Meeting concerning the need to develop testing requirements for equipment with multi-point calibration capability.

Mr. Andersen suggested that the specifics of what testing is required would best be addressed in the NIST EPOs. Mr. Karimov expressed concern about testing at flow rates which create pressures exceeding the rated pressure of the meter. The Committee heard additional comments from conference members expressing confusion over what minimum testing should be required.

Mr. Michael Keilty (Endress + Hauser), chairman of the NTEP Measuring Sector, recommended that the item be moved to an information status. He suggested asking the Sector to review this issue and provide suggestions to the Committee on how to best address special tests on wholesale devices. This suggestion was supported by several other NCWM members.

The Committee agreed to ask the Measuring Sector to review and provide suggestions on this issue. Consequently, it changed the status of this item from "Voting" to "Informational" to allow for additional input from the Sector and other interested parties.

330-4 I UR.3.3. Computing Device.

Source:

NCWM Task Group on Retail Motor Fuel Dispenser Price Posting and Computing Capability (2013)

Purpose:

Refine the criteria in the LMD Code related to price posting and computing capability of RMFDs for post-delivery discounted transactions to more clearly reflect the recommendations of the NCWM Task Group on RMFD Price Posting and Computing Capability for the indication of the highest unit price.

Item under Consideration:

Amend paragraph UR.3.3.(c) as follows to: 1) add the underlined text; and 2) modify the alignment of the statement regarding electronic receipts following paragraph UR.3.3.(c)(2) such that it aligns with parts (a), (b), and (c):

UR.3.3. Computing Device. – Any computing device used in an application where a product or grade is offered for sale at one or more unit prices shall be used only for sales for which the device computes and displays the sales price for the selected transaction.

(Added 1989) (Amended 1992)

The following exceptions apply:

- (a) Fleet sales and other price contract sales are exempt from this requirement.
- (b) A truck stop dispenser used exclusively for refueling trucks is exempt from this requirement provided that:
 - (1) all purchases of fuel are accompanied by a printed receipt of the transaction containing the applicable price per gallon, the total gallons delivered, and the total price of the sale; and
(Added 1993)

- (2) unless a dispenser complies with S.1.6.4.1. Display of Unit Price, the price posted on the dispenser and the price at which the dispenser is set to compute shall be the highest price for any transaction which may be conducted.
(Added 1993)
- (c) A dispenser used in an application where a price per unit discount is offered following the delivery is exempt from this requirement, provided the following conditions are satisfied:
- (1) the unit price posted on the dispenser and the unit price at which the dispenser is set to compute **prior to the application of any discount** shall be the highest unit price for any transaction;
 - (2) all purchases of fuel are accompanied by a printed **or electronic** receipt **upon purchaser demand** recorded by the system for the transaction containing:
 - a. the product identity by name, symbol, abbreviation, or code number;
 - b. transaction information as shown on the dispenser at the end of the delivery and prior to any post-delivery discount including the:
 1. total volume of the delivery;
 2. unit price; and
 3. total computed price of the fuel sale prior to post-delivery discounts being applied.
 - c. an itemization of the post-delivery discounts to the unit price; and
 - d. the final total price of the fuel sale.

For systems equipped with the capability to issue an electronic receipt, the customer may be given the option to receive the receipt electronically (e.g., via cell phone, computer, etc.)

(Added 2012)

(Added 1998) (Amended 1992, 1993, and 2012)

Background/Discussion:

2013 NCWM Interim Meeting: The NCWM Task Group (TG) on RMFD Price Posting and Computing Capability met to review examples of receipts and scenarios for compliance with language adopted into NIST Handbook 44 in 2012 to address systems that are used to offer post-delivery discount pricing in retail motor-fuel dispensing applications. During that review, the TG noted that the language in paragraph UR.3.3.(c)(1) could be incorrectly interpreted to prohibit the application of both pre- and post-delivery discounts in a single transaction; the TG develop proposed changes to the paragraph to address this concern. The current language in (c)(1) states that, in order to qualify for the exemptions offered for post-delivery discounts, the unit price posted on the dispenser and the unit price at which the dispenser is set to compute shall be the highest unit price for any transaction. In instances where a customer elects to receive a discount prior to the delivery (i.e., a “pre-delivery” discount), this might create an unintended conflict. For example, if a customer elects to pay in cash at the start of the transaction, the dispenser might display and compute at a lower, cash unit price. Since UR.3.3.(c)(1) stipulates posting and computing at the highest unit price, some might interpret this to mean that this dispenser may not also participate in post-delivery discount pricing or be entitled to the exemptions in U.R.3.3.(c). The original intent of the changes proposed by the TG and adopted by the NCWM was not to restrict systems from participating in both pre- and post-delivery discounting. Consequently, the TG proposes changes as outlined in UR.3.3.(c)(1) in the Item Under Consideration above.

The TG also developed proposed changes to UR.3.3.(c)(2) as shows in the Item Under Consideration to acknowledge that: 1) the system must be able to provide a receipt to the customer, but the customer can be given an

option of receiving the receipt or not; and 2) an electronic receipt is an acceptable alternative to a hard copy receipt if the purchaser agrees to an electronic receipt in lieu of, or in addition to, a hard copy. The Task Group believes that, should a customer prefer not to receive a receipt or prefer to receive it electronically, this should be permissible.

Lastly, the TG recommended changing the vertical alignment of the statement following UR.3.3.(c)(2) regarding the option of an electronic receipt so that it clearly applies to UR.3.3.(a), (b), and (c) rather than just part (c). As presently shown in NIST Handbook 44, this statement would apply only to UR.3.3.(c). The text shown in the Item Under Consideration above aligns that statement such that it would apply to UR.3.3.(a), (b), and (c).

The Committee agreed to add this item to its agenda to address these changes proposed by the TG. The Committee believes the proposed changes have merit and believe they simply clarify the original intent of the language developed by the TG and adopted by the NCWM. However, because the proposed changes were not available for publication and review in NCWM Publication 15, the Committee agreed that the item should be designated as an Informational item to allow adequate opportunity for the review and comment by all stakeholders potentially affected by the proposed changes. The Committee also believes this will provide an opportunity for input on the specific language to ensure that it clearly and adequately addresses the concerns identified by the TG.

The Committee agreed to retain Item 360-3 as a Developing Item while the TG continues work to develop guidelines and examples on how the changes made to the LMD Code in 2012 will apply to receipts for post-delivery discounted transactions. See Item 360-3 for additional background information on this work.

2013 NEWMA Annual Meeting: NEWMA recommended this item be designated as a “Voting” Item on the NCWM Agenda in the 2014 NCWM cycle. NEWMA believes that the proposed changes will help clarify the intent of the WG’s original suggestion.

2013 CWMA Annual Meeting: The CWMA recommended the item be designated as an “Information” Item.

Two government representatives supported the proposed changes and one government representative indicated a neutral position on the item in the 2013 NCWM Online Position Forum.

2013 Annual Meeting: The Committee heard comments from OWM suggesting that the proposed modifications to UR.3.3.(c)(2) are unnecessary given that the paragraph already includes the following statement permitting the use of electronic receipts.

For systems equipped with the capability to issue an electronic receipt, the customer may be given the option to receive the receipt electronically (e.g., via cell phone, computer, etc.).

Similar provisions are included in paragraphs S.1.6.7. Recorded Representations and S.1.6.8. Recorded Representations for Transactions Where a Post-Delivery Discount(s) is Provided. NIST, OWM also noted that the proposed wording in UR.3.3.(c)(2) inadvertently requires that the system be capable of providing an electronic receipt upon customer demand, regardless of whether or not the system is capable of providing one. The Committee heard multiple comments in support of eliminating the proposed revisions to UR.3.3.(c)(2). The Committee also heard comments from multiple weights and measures jurisdictions expressing the need to retain the requirement for a hard copy receipt for those consumers who do not have access to an electronic version. Mr. Ross Andersen (New York, retired) noted the need to consider any requirements at the state level that apply to electronic records.

Comments received during the Open Hearings indicated that, in applications where receipts are required, the following principles should apply:

- A printed receipt must be made available to the customer.
- If a customer doesn’t want a receipt, it is not necessary to provide one.
- The customer may be given the option of receiving an electronic receipt in lieu of a printed receipt.

The Committee also heard comments from both weights and measures jurisdictions and industry representatives suggesting that a provision be added to the General Code recognizing the acceptance of electronic receipts. Mr. Matt Curran (Florida) commented that identifying and defining different types of discounts, such as “rebates,” would be helpful for consumers as well as officials in understanding how these requirements apply.

331 VEHICLE-TANK METERS

331-1 VC Table 1. Accuracy Classes and Tolerances for Vehicle-Tank Meters

(This item was adopted.)

Source:

NIST, Office of Weights and Measures (2013)

Purpose:

Resolve inconsistencies in the temperature ranges defined for Heated Products among NIST Handbook 44, Liquid-Measuring Devices, Vehicle Tank-Meters, and Mass Flow Meters Codes.

Item Under Consideration:

Amend Table 1 as follows:

Table 1. Accuracy Classes and Tolerances for Vehicle-Tank Meters					
Accuracy Class	Application	Acceptance Tolerance	Maintenance Tolerance	Special Test Tolerance	
0.3	<ul style="list-style-type: none"> - Petroleum products delivered from large capacity (flow rates over 115 L/min or 30 gpm)** devices, including motor-fuel devices - Heated products (other than asphalt) at or temperatures greater than 50 °C (122 °F) - Asphalt at temperatures equal to or below a temperature of 50 °C (122 °F) - All other liquids not shown in the table where the typical delivery is greater than 200 L (50 gal) 	0.15 %	0.3 %	0.45 %	
0.3A	<ul style="list-style-type: none"> - Asphalt at temperatures greater than 50 °C (122 °F) 	0.3 %	0.3 %	0.5 %	
0.5*	<ul style="list-style-type: none"> - Petroleum products delivered from small capacity (at 4 L/min (1 gpm) through 115 L/min or 30 gpm)** motor-fuel devices - Agri-chemical liquids - All other applications not shown in the table where the typical delivery is ≤ 200 L (50 gal) 	0.3 %	0.5 %	0.5 %	
1.1	<ul style="list-style-type: none"> - Petroleum products and other normal liquids from devices with flow rates** less than 4 L/min (1 gpm) and - Devices designed to deliver less than 4 L (1 gal) 	0.75 %	1.0 %	1.25 %	
1.5	- Water	Overregistration	1.5 %	1.5 %	1.5 %
		Underregistration	1.5 %	1.5 %	5.0 %

Table 1.
Accuracy Classes and Tolerances for Vehicle-Tank Meters

Accuracy Class	Application	Acceptance Tolerance	Maintenance Tolerance	Special Test Tolerance
<p>* For 5 gal and 10 gal test drafts, the tolerances specified for Accuracy Class 0.5 in the table above do not apply. For these test drafts, the maintenance tolerances on normal and special tests for 5 gal and 10 gal test drafts are 6 in³ and 11 in³, respectively. Acceptance tolerances on normal and special tests are 3 in³ and 5.5 in³.</p> <p>** Flow rate refers to designed or marked maximum flow rate.</p>				

(Added 2002) (**Amended 2013**)

Background/Discussion:

This item was initiated as a result of discussions at an NTEP measuring labs meeting and forwarded to the Measuring Sector for review in 2011. In reviewing criteria for heated products during discussions at the 2011 annual NTEP Laboratory Meeting, the Measuring Laboratories noted inconsistencies in the way that heated products are referenced in the LMD, VTM, and MFM Codes.

The differentiation between “heated” and “non-heated” products first appeared in NIST Handbook 44 in 2000 as a result of a proposal adopted by the NCWM in 1999 to expand the tolerances applicable to meters used to measure asphalt above 50 °C (see S&T Committee Items 330-6 and 337-4 in the 1999 NCWM S&T Committee Final Report for details). This reference was refined by the Committee in 2001 when changes were adopted to clarify the application of tolerances to asphalt at 50 °C in the LMD and MFM Codes. When the LMD and VTM Codes were modified in 2003 and 2004 to adopt an accuracy class table to mirror the MFM Code, inconsistencies first appeared in the way that heated products were referenced among the codes.

This proposal and similar proposals elsewhere in the Committee’s agenda, suggest changes to correct these inconsistencies. A summary of the proposals is listed below.

Section: 3.30. Liquid-Measuring Devices; Table T.2. (S&T Item 330-2)

Section: 3.31. Vehicle-Tank Meters; Table 1. (S&T Item 331-1)

Section: 3.37. Mass Flow Meters; Table T.2. (S&T Item 337-3)

NIST OWM notes that there also may be a need to address hot water meters (for which the American Water Works Association (AWWA) defines a boundary temperature of 90 °F) in NIST Handbook 44.

The proposed changes in these items take into account corresponding references to heated products in NCWM Publication 14, including the “Product Families Table” in Technical Policy C and past discussions at meetings of the NTEP Measuring Sector. Revisions are also proposed to ensure appropriate references to both Fahrenheit and Celsius temperatures.

NEWMA and SWMA supported moving this item forward as a Voting Item at their 2012 Annual Meetings. The SWMA also recommended that this item be consolidated with correlating items in the VTM and MFM during the voting process to help ensure consistency among these codes.

2013 NCWM Interim Meeting: The Committee received comments in writing from NIST, OWM as outlined in Item 330-2 and heard a synopsis of these comments from Ms. Juana Williams (NIST, OWM) during the Open Hearings. The Committee heard comments from Mr. Michael Keilty (Endress + Hauser), who agreed with NIST, OWM’s comments and further suggested that discussion be taken simultaneously on this item and Items 330-2 and 337-3 for expediency. Hearing no opposition to the proposed changes, the Committee agreed to move this item forward for a Vote.

2013 spring NEWMA and CWMA Annual Meetings: NEWMA and the CWMA supported the designation of this item as a Voting Item and agreed with the need to resolve current inconsistencies. Three government representatives indicated support and one government representative indicated a neutral position for this item on the NCWM Online Position Forum with no additional comments.

2013 NCWM Annual Meeting: The Committee took comments on this item simultaneously with Items 330-2 and 337-3. See Item 330-2 for additional details.

331-2 VC T.4. Product Depletion Test

(This item was adopted.)

Source:

Northeastern Weights and Measures Association (2009 Developing Items Part 3.31., Vehicle-Tank Meters - Item 1.)

Purpose:

Enable more consistent application of the tolerances between older and newer meters and address an unintentional gap that allows an unreasonably large tolerance for smaller meters.

Item Under Consideration:

Amend paragraph T.4. and delete Table T.4 as show below. Note that this option was identified as “Option 2” in the Committee’s 2012 Final Report.

T.4. Product Depletion Test. – The difference between the test result for any normal test and the product depletion test shall not exceed ~~tolerance shown in Table T.4.~~ **0.5 % of the volume delivered in one minute at the maximum flow rate marked on the meter for meters rated higher than 380 Lpm (100 gpm) or 0.6 % of the volume delivered in one minute at the maximum flow rate marked on the meter for meters rated 380 Lpm (100 gpm) or lower.** Test drafts shall be of the same size and run at approximately the same flow rate.

Note: The result of the product depletion test may fall outside of the applicable test tolerance as specified in Table 1. Accuracy Classes and Tolerances for Vehicle-Tank Meters.

Delete current Table T.4.

Table T.4.	
Tolerances for Vehicle-Tank Meters on Product Depletion Tests, Except Milk Meters	
Meters Size	Maintenance and Acceptance Tolerances
Up to, but not including, 50 mm (2 in)	1.70 L (104 in³)¹
From 50 mm (2 in) up to, but not including, 75 mm (3 in)	2.25 L (137 in³)¹
75 mm (3 in) or larger	3.75 L (229 in³)¹
Based on a test volume of at least the amount specified in N.3. Test Drafts.	

Background/Discussion:

This item was submitted to NEWMA at its 2008 Interim Meeting to propose an alternative to existing product depletion test tolerances which are based on the size of the meter. The Committee has agreed with the concept of basing the product depletion test tolerances on the marked maximum flow rate of the meter rather than on the marked meter size and considered several proposals for modifying the tolerances since this item was introduced in 2008. Details of these proposals and associated discussion can be found in the Committee’s 2009-2012 final reports.

While recognizing that one goal of the original proposal was to reduce what the submitter considered an unreasonably large tolerance for smaller meters, the Committee expressed concern about the impact the proposal would have on these meters based on comments from Meter Manufacturers Association (MMA). From 2009 to 2011, the Committee repeatedly requested data from industry and weights and measures officials to support

or oppose the proposals under consideration. In late 2011, nine county jurisdictions submitted field test data to the Committee for review.

2012 NCWM Interim Meeting: The Committee considered three options for modifying NIST Handbook 44. A summary of how the three options would apply is outlined in the following table. A second table illustrating examples of tolerances for common meter sizes and maximum flow rates is also included.

Summary of Product Depletion Tolerance Options Considered		
	Marked Maximum Flow Rate or Meter Size	Tolerance (% of Marked Max Flow Rate)
Current	Up to but not including 2 in	104 in ³
	2 in up to but not including 3 in	137 in ³
	3 in and larger	229 in ³
Option 1:	All Maximum Flow Rates	0.5 %
Option 2:	Marked Max ≤ 100 gpm	0.6 %
	Marked Max > 100 gpm	0.5 %
Option 3:	Marked Max ≤ 60 gpm	0.8 %
	Marked Max > 60 gpm up to and including 100 gpm	0.6 %
	Marked Max > 100 gpm	0.5 %

Examples of Product Depletion Tolerance Options for Different Meter Sizes/Flow Rates					
Size	Marked Maximum Flow Rate (gpm)	Current Tolerance	Option 1 (0.5 % max)	Option 2 (0.6 % max) (0.5 % max)	Option 3 (0.8 % max) (0.6 % max) (0.5 % max)
1-1/2 in	60 gpm	104 in ³	69 in ³	83 in ³	111 in ³
2 in	100 gpm	137 in ³	115 in ³	139 in ³	139 in ³
2 in	150 gpm	137 in ³	173 in ³	173 in ³	173 in ³
3 in	150 gpm	229 in ³	173 in ³	173 in ³	173 in ³
3 in	200 gpm	229 in ³	231 in ³	231 in ³	231 in ³
3 in	300 gpm	229 in ³	346 in ³	346 in ³	346 in ³
3 in	350 gpm	229 in ³	404 in ³	404 in ³	404 in ³

The Committee requested and received product depletion test data from multiple weights and measures jurisdictions. A summary of the data for each jurisdiction can be viewed in the Committee’s 2012 Final Report. The following table provides a summary of the data for all jurisdictions.

	Total Meters	Failed Current Tolerance	Failed Option 1	Failed Option 2	Failed Option 3	Marked Maximum Flow Rate
Summary of All Jurisdictions	156	3	13	10	4	60 gpm
	1463	53	91	52	52	100 gpm
	222	12	11	11	11	> 100 gpm
	81	26	26	20	20	No Info
Totals	1922	94	141	93	87	

While acknowledging that the data was not obtained under controlled conditions or as part of a structured study, the Committee noted that the data was extremely valuable in assessing the relative impact of the three options proposed. The Committee agreed that Option 2 represented a reasonable compromise between the original proposal, Option 1, and the MMA’s proposal, Option 3. The Committee proposed this option as an Informational Item to allow time for any additional input with the intent of moving the item to Voting in 2013.

2012 fall regional NCWM Annual Meeting: “The Committee heard comments from MMA supporting the proposal.

2012 fall regional meetings: The weights and measures associations supported proposing Option 2 as a Voting Item in 2013. At the fall 2012 SWMA meeting, Mr. Michael Keilty (Endress + Hauser) reported on behalf of the Measuring Sector that the Sector thoroughly discussed this issue at its October 2012 meeting and agreed that Option 2 should be proposed for a Vote.

2013 NCWM Interim Meeting Open Hearings: The Committee heard comments from Mr. Ross Andersen (New York, retired) and Mr. Dmitri Karimov (Liquid Controls Corporation, LLC) supporting the proposed changes and encouraging the Committee to finalize the language. Hearing no opposition to the proposal, the Committee agreed to move it forward for a Vote.

2013 NEWMA and the CWMA Annual Meetings: Comments were heard indicating that the expression of the tolerance as it applies to a “volume delivered in one minute” may be confusing to some.

To address this concern, NEWMA proposed including a table illustrating common examples of meter flow rates (similar to the table shown earlier in this item) be added to the NIST EPOs to assist field officials and industry in understanding the intended application of the requirements. The CWMA proposed the following changes to paragraph T.4. Product Depletion Test shown in Item Under Consideration:

- T.4. Product Depletion Test.** – The difference between the test result for any normal test and the product depletion test shall not exceed ~~tolerance shown in Table T.4. 0.5 % of the volume delivered in one minute at the maximum flow rate marked on the meter for meters rated higher than 380 Lpm (100 gpm) or 0.6 % of the volume delivered in one minute at the maximum flow rate marked on the meter for meters rated 380 Lpm (100 gpm) or lower.~~ Test drafts shall be of the same size and run at approximately the same flow rate.

Both NEWMA and the CWMA recommended the item be designated as a Voting Item.

Two government representatives indicated support and two government representatives indicated a neutral position for this item on the NCWM Online Position Forum with no additional comments.

2013 NCWM Annual Meeting: The Committee considered the additional revisions proposed by the CWMA to remove the reference to “the volume delivered in one minute.” OWM noted that this would result in a tolerance expressed in gallons per minute. The phrase “the volume delivered in one minute” may seem a bit unwieldy; however, the flow rate marked on most meters is expressed in terms of a quantity per time such as “liters per minute” or “gallons per minute.” If the reference to the time period of “one minute” were deleted from the paragraph as suggested by the CWMA, the application of the tolerance would result in a “quantity per minute” rather than a finite “quantity in liters” or “quantity in gallons.”

For example, if a meter were marked with a maximum flow rate of 100 gpm, the tolerance would be applied as follows:

$$0.6 \% \times 100 \text{ gal/min} = 0.6 \text{ gal/min}$$

In contrast, applying the tolerance to that same meter as specified in the Item Under Consideration would result in a tolerance expressed in gallons as illustrated below:

Amount delivered in one minute at the maximum flow rate marked on the meter =

$$1 \text{ min} \times 100 \text{ gal/min} = 100 \text{ gal}$$

$$\text{Tolerance} = 0.6 \% \times 100 \text{ gal} = 0.6 \text{ gal}$$

Thus, OWM believes that it would be incorrect to remove the phrase “the volume delivered in one minute” from the paragraph. The suggestion provided by NEWMA may provide a more palatable alternative to help illustrate how the tolerance is applied and OWM could include such examples in both the NIST EPOs and training materials.

Consequently, the Committee agreed with the Item Under Consideration as originally proposed. The Committee concurred with NEWMA's suggestion to include examples in the NIST EPOs and training materials.

336 WATER METERS

336-1 V UR.3. Installation Requirements

(This item was returned to Committee.)

Source:

Neptune Technology Group Inc. (2013)

Purpose:

Establish installation requirements in the Water Meters Code.

Item Under Consideration:

Add a new paragraph UR.3. as follows:

UR.3. Installation Requirements.

UR.3.1. Manufacturer's Instructions. – A water meter shall be installed in accordance with the manufacturer's instructions. For utility type water meters, the installation shall be sufficiently secure and rigid to maintain this condition.

Background/Discussion:

There are no installation requirements for utility type meters in the Water Meters Code of NIST Handbook 44. The submitter proposed the following new paragraph be added to Section 3.36.:

UR.3. Installation Requirements.

UR.3.1. Manufacturer's Instructions. – A utility type water meter shall be installed in accordance with the manufacturer's instructions, and the installation shall be sufficiently secure and rigid to maintain this condition.

2012 WWMA Annual Meeting: Mr. Andre Noel (Neptune) indicated that Neptune, Badger, Sensus, Elster-AMCO, and Master Meter support this item. Mr. Ron Hassmeyer (Alameda County, California) supported the item, but voiced concerns related to installation such as meter visibility. Ms. Kristin Macey (California) advised that there may be possible conflicts with other code language coming from other organizations such as AWWA and the Public Utilities Commission (PUC). The WWMA found it reasonable that the manufacturer's instructions would be the basis for such installations. This proposal is similar to language used in NIST Handbook 44, LMD Code paragraph UR.2.1.; MFM Code paragraph UR.2.1.; and Hydrogen Gas-Measuring Devices Code paragraph UR. 2.1. The WWMA also noted that UR.2. Accessibility of Customer Indications already addresses the issues of visibility. WWMA forwarded the item to NCWM, recommending it as a Voting Item.

2013 NCWM Interim Meeting: The Committee heard comments in support of the proposal from Mr. Noel, who indicated that he also spoke on behalf of Badger, Sensus, Elster-AMCO, and Master Meter and noted that the proposed change would mirror similar paragraphs in other NIST Handbook 44 measuring device codes. Mr. Jim Byers (San Diego County, California) stated that he agreed with the proposed requirement, but notes that the General Code already addresses these requirements. He suggested that, if the language in the General Code is not sufficient, then that language should be reviewed and revised rather than including additional language in the specific code. Ms. Kristin Macy (California) stated that California agrees with Mr. Byers and believes that the language in the General Code is sufficient. Ms. Juana Williams (NIST, OWM) also acknowledged the similarity with language in other codes.

While the Committee acknowledged comments regarding the redundancy of the proposed paragraph with current General Code requirements, the Committee believes the proposal has merit in helping to ensure proper installation of water meters. The Committee believes the requirement in the first sentence of the proposed paragraph regarding compliance with the manufacturer's instructions should apply to all water meters, not just utility type meters. Consequently, the Committee modified the language to restrict only the second sentence to utility type water meters and agreed to propose the modified paragraph (as shown in the Item Under Consideration above) for a Vote.

2013 Annual Meetings: NEWMA and the CWMA recommended this item be designated as Voting.

One government representative indicated support; one government representative indicated a neutral position; and one government representative indicated opposition for this item on the NCWM Online Position Forum. The opposing comment was accompanied by a statement indicating that paragraph G-UR.2.1. is adequate to address this concern and that paragraph is also more complete and better articulates the requirements.

2013 NCWM Annual Meeting Open Hearings, the Committee heard comments in opposition to this item from Mr. Michael Keilty (Endress & Hauser Flowtec AG, USA) and Ms. Macey suggesting that the adding of requirements to address installation would be redundant. Mr. Keilty expressed concern that the absence of specific requirements such as these in *all* specific device codes might cause confusion about how or if the General Code paragraph would apply in those cases. Ms. Macey also expressed opposition to distinguishing between non-utility type and utility type water meters. NIST, OWM commented that the proposed language is consistent with that appearing in other device codes in NIST Handbook 44 and intended for the same purpose. The Committee received letters of support from Badger Meter; Elster AMCO Water, LLC; Sensus; Master Meter, Inc.; and Neptune Technology Group. Mr. Dmitri Karimov (Liquid Controls Corporation), speaking on behalf of the companies who were unable to attend this meeting and the Meter Manufacturers Association, also expressed support for this item.

337 MASS FLOW METERS

337-1 I Appendix D – Definitions: Diesel Liter and Diesel Gallon Equivalents (DLE, DGE)

Source:

Clean Vehicle Education Foundation (2013)

Purpose:

Enable consumers to make cost and fuel economy comparisons between diesel fuel and natural gas.

Item Under Consideration:

Add the following definitions to Appendix D – Definitions:

Diesel Liter Equivalent (DLE). - means 0.756 kg of natural gas.

Diesel Gallon Equivalent (DGE). - means 2.863 kg (6.312 lb) of natural gas.

Background/Discussion:

The gasoline gallon equivalent (GGE) unit was defined by NIST/NCWM in 1994 (See Appendix A) to allow users of natural gas vehicles to readily compare costs and fuel economy of light-duty natural gas vehicles with equivalent gasoline powered vehicles. For the medium and heavy duty natural gas vehicles in widespread use today, there is a need to officially define a unit (already in widespread use) allowing a comparison of cost and fuel economy with diesel powered vehicles. Also natural gas is sold as a vehicle fuel as either Compressed Natural Gas (CNG) or Liquefied Natural Gas (LNG) and each method of sale is measured in mass. Therefore, the generic term, natural gas is proposed to be used in NIST Handbooks 44 and 130 with out the existing term "compressed." The mathematics justifying the specific quantity (mass) of natural gas in a DLE and DGE is included in Appendix A.

The official definition of a DLE and a DGE will likely provide justification for California, Wisconsin, and any other state to permit retail sales of LNG for heavy-duty vehicles in these convenient units.

2012 Interim Meeting: CWMA supported putting definitions of diesel liter equivalent and diesel gallon equivalent for natural gas into NIST Handbook 44, provided that FALS confirms the conversion factor prior to voting. CWMA forwarded the item to NCWM, recommending it as a Voting Item.

2012 WWMA Annual Meeting: Ms. Williams, NIST Technical Advisor advised that there are corresponding L&R Items 232-1 & 237-1, and suggested that the S&T and L&R Committees need to work on these items in tandem. The Committee believed this item has merit. The WWMA expressed concerns with the source of equivalency values derived, noting it would like validation as to whether the values accurately represent the actual value of various types of natural gas products. The WWMA realized there are different compositions and sources. For example, LNG has a higher methane composition. There may be a possibility of additional conversion factors based on BTUs from different sources. The WWMA S&T Committee acknowledged meeting with the WWMA L&R Committee regarding this item. The two committees differed in their recommendations, between Informational and Developmental Item Status on the NCWM agenda. WWMA forwarded the item to NCWM recommending it as a Developing Item.

2012 Interim Meeting: NEWMA agreed to forward the item to NCWM, recommending it as an Informational Item.

2012 SWMA Annual Meeting: Mr. Michael Keilty (Endress + Hauser) noted some confusion about the values designated in the proposal. He also commented that there appears to be confusion about what the dispenser will display, particularly for dispensers that will serve vehicle types that run on gasoline as well as vehicle types that could run on diesel. He asked whether the units will display in both GLE/GGE and DLE/DGE and how the dispenser will display this information. He suggested that this item be designated as a Developing Item to allow additional time to address these concerns. The SWMA reported that it did not believe that the proposal had been adequately developed with regard to the application of the proposed definitions, including aspects such as vetting of these values within the industry relative to actual gas supplies; explanation of how this will be applied consistently; and provisions for ensuring clear and understandable value comparisons by consumers (particularly given variations in gas supplies); and how this will apply to dispensers that may be used to fuel vehicles conventionally fueled by gasoline or diesel. The SWMA questioned whether it might be more appropriate for the community to consider establishing mass as the method of sale for natural gas and providing educational information through mechanisms such as pump toppers that would enable the consumer to compare the fuel costs with gasoline- or diesel-powered vehicles. This approach would eliminate concerns about designating equivalent values that may not accurately represent the product being sold through a specific dispenser. SWMA unanimously agreed to forward the item to NCWM, recommending it as a Developing Item with development assigned to the submitter.

2013 NCWM Interim Meeting: The Committee heard multiple comments in opposition to the proposal. Mr. Keilty opposed the proposal, noting that a truck running on LNG would be dedicated to that type of fuel; thus, there is no need to make comparisons with diesel fuel on an ongoing basis. He believes natural gas should be sold in units of mass. Ms. Williams reviewed the following points prepared by OWM and suggested that the Committee consider these points in its deliberations on the proposals for this Item and Item 337-2. A copy of these points was also provided to the S&T Committee and the L&R Committee in writing in advance of the Interim Meeting.

Collaborative Work Effort

Work in joint session with the NCWM L&R Committee on corresponding L&R Agenda Items 232-1 (a proposal to recognize the diesel volume equivalent MOS for vehicle fuel) and 237-1 (a proposal to define the diesel volume equivalent unit in relation to mass) which specify the allowable unit of measurement for advertising and sale of natural gas. This collaboration between Committees will ensure that the proposed volume equivalent unit for a delivery is properly indicated and calculated by a natural gas dispenser.

Facilitate Marketplace-Value Comparisons

A dispenser might serve vehicles that are powered by diesel or gasoline fuel. Therefore, which volume equivalent unit (the DGE or GGE) is appropriate to avoid confusing the consumer? What is the most appropriate means to provide sufficient information to customers attempting to make a comparison of fuel offered by the DGE and GGE, whether at the same station or stations on adjacent street corners? Today's value comparisons are made to petroleum products, but as other alternative fuels proliferate how easy will it be for consumers to make comparisons

to other fuels such as electricity or hydrogen?

An alternative that would provide more flexibility for comparison with other fuels and which would potentially create less confusion than permitting multiple different “equivalent” values as “units” of measure is to require the sale of all natural gas in mass units (kg or lb) as suggested by the SWMA. With this approach, customers could still be provided with supplemental information through mechanisms such as pump toppers that provide information about estimated equivalent units of measurement for deliveries indicated in mass as well as information on web sites such as those that already provide information about fuel economy. This approach might also reduce complaints from some suppliers about the accuracy of equivalent values relative to their product.

Another point that has been raised by some in the community and should be considered by the Committee is whether or not “equivalent values” are as necessary as they might have been at one time to encourage consumer acceptance of natural gas as an alternative fuel. For example, the SWMA questioned whether, once a consumer has purchased a vehicle he or she has the need to make ongoing value comparisons or whether this information is more useful prior to purchasing a vehicle. Given the concerns about consumer confusion with a potential proliferation of “equivalent” values at the dispenser, perhaps requiring mass units on the dispenser (with supplemental information about equivalents) is a more appropriate approach.

Compliance of Existing Approved Equipment-Indications

As noted above, NIST OWM suggests the Committee consider SWMA’s recommendation for equipment to indicate in a mass unit of measurement. Currently, there are two LNG dispensers with NCWM NTEP Certificates of Conformance (CC). They are NCWM CC 02-075A2* (Chart Industries) and NCWM CC 04-073A1 (NorthStar, Inc.), which specify these dispensers display in mass. How will the proposal apply to this equipment that may not have the capability to display in units other than mass?

Earlier S&T Committee Positions

Does the S&T Committee plan to revisit its 1999 recommendation where it requested data on LNG be submitted prior to the recognition of this product in a metering application? The Committee might also recall that the S&T Committee took a position in 2008 on a related proposal to recognize the “DGE” recommending that a consensus between stakeholders exist on any single energy value used as a conversion factor. NIST OWM notes that several CNG suppliers have raised concerns about the use of 5.660 lb of CNG for each GGE commenting that this value is too low for the fuel they are providing to customers. OWM asks are other Sectors, which rely on the accurate accounting of vehicle motor fuel sales, aware of and in agreement with the proposed mass to volume equivalent unit being proposed as a conversion factor value for natural gas (CNG and LNG)?

The data for the heating values cited in Table B.4. “Heat Content for Various Fuels” in the Transportation Energy Data Book Edition 30 (June 2011) was not developed as part of an NCWM study, but represents an account of work by a government sponsored agency to characterize transportation activity and other factors that influence transportation energy use. The book includes a disclaimer which states “in any attempt to compile a comprehensive set of statistics on transportation activity, numerous instances of inadequacies and inaccuracies in the basic data are encountered;” points out that “an appendix is included to document the estimation procedures;” and notes that “neither ORNL nor DOE endorses the validity of these data.”

Ms. Kristin Macey (California) opposed the proposal and urged the Committee to stop the proliferation of “equivalent units.” She noted that mass units are perfectly good for routine transactions and echoed comments that comparisons with other fuels are only relevant when making a purchase decision. Ms. Carol Hockert (NIST, OWM) further suggested that, during its deliberations, the Committee should consider how the establishment of artificial units would affect metrological traceability. Mr. Karimov (Liquid Controls Corporation, LLC), speaking on behalf of MMA, agreed with Ms. Hockert, noting that extensive work is done by companies to establish and maintain metrological traceability and the establishment of what amounts to arbitrary values is counterproductive. Mr. Dan Peterson (Yokogawa Corporation of America) echoed all of the statements made in opposition to the proposal.

Mr. Curtis Williams (CP Williams Energy Consulting) stated that he has had concerns about the use of the GGE and GLE for some years and he is glad that some are questioning the need to reconsider the use of equivalent units. As a participant in the U.S. National Working Group on Hydrogen, he was grateful that the associated code for that alternative fuel established requirements for mass units. He suggested that the Committee also consider examining the potential use of mass units for other fuels and noted that the use of mass units also eliminates questions about temperature compensation.

Ms. Judy Cardin (Wisconsin) acknowledged the need for the L&R Committee and the S&T Committee to work together on this and related items. She cited two main tasks to be addressed as: 1) What is the right conversion value for the proposed units?; and 2) Should units for the sale of natural gas be in “equivalent” units or mass units?

The Committee heard no comments in support of the proposal during its Open Hearings.

During its work sessions at the Interim Meeting, the S&T Committee met with the L&R Committee to discuss this item and related items on the two Committees’ agendas; the corresponding items on the L&R Committee Agenda are Items 232-1 and 237-1. During the joint meeting, the L&R Committee advised the S&T Committee that it had decided to make the related item on their agenda “Informational” to allow additional time for the community to study the issue and hear from other stakeholders in the community. A proposal was made to ask the FALS to deliberate on an appropriate equivalent value for each of the proposed “units.” However, the two Committees recognized that before asking the FALS to expend resources on further definition, the questions and concerns raised in the Open Hearings regarding the appropriateness of recognizing such units should first be addressed. The Committees agreed to recommend to the NCWM Chairman that a small task group be established to further study this issue. The Committees each agreed to develop a list of tasks that they would ask such a task group to take on and to recommend possible members of the group to ensure balanced representation of stakeholders.

After discussion with the L&R Committee, the S&T Committee reviewed and summarized key comments made during the Open Hearings for S&T Committee Agenda Items 337-1 and 337-2:

- Are equivalent units necessary to promote consumer acceptance of this fuel?
- Is there a significant need for continued comparison to other fuels once you have purchased a vehicle? Does this justify the proliferation of “equivalent” values?
- The intent is to add this for medium- and heavy-duty vehicles such as trucks that operate on LNG. Trucks that operate on LNG are generally dedicated fuel vehicles that run only on a single fuel.
- Is the dispenser the appropriate place to make comparisons with other fuels or is a better place to make those comparisons via mechanisms such as pump toppers, websites, etc.?
- Striking the word “compressed” (in the changes proposed in Item 337-2) expands the proposal to LNG.
- California’s approval of LNG meters indicating in mass units was correct.
- What will the impact be on existing approval of LNG dispensers currently indicating in mass?
- There is much opposition to the proliferation of “equivalent units” for various types of fuels.
- The current recognition of GGE and GLE units has led to complaints about equivalent values from both industry and regulatory officials.
- Mass units should be considered for natural gas and other fuels.
- Will the establishment of equivalent values provide traceability to SI units?

- The community expends significant resources to achieve good meter performance and establishing “fuzzy” equivalent values seems to undermine these efforts.
- The factor for any “equivalent unit” will represent only an “estimate” of an equivalent value.
- There is disagreement amongst the industry regarding the appropriate equivalent value in this proposal. The report containing the data that is referenced as the basis for the proposal includes a disclaimer from Oakridge National Laboratory and U.S. Department of Energy regarding its validity for other than general use in the transportation industry.
- The S&T Committee only heard comments in opposition to the proposal.
- Harmonization with OIML requirements should be considered in the method of sale and associated device requirements.

With respect to Items 337-1 and 337-2, the Committee agreed to work collaboratively with the L&R Committee and to develop a small work group to decide: 1) whether or not DLE and DGE should be considered an acceptable method of sale for natural gas; and 2) if so, what should the factor be to determine their equivalents to gasoline. The Committee agreed that the above list of key points and questions heard during its Open Hearings should be considered, along with other Open Hearing comments, by the chairs of both the L&R and S&T Committee in the development of a list of points to be addressed by the Task Group.

2013 Annual Meeting: NEWMA recommended this item be withdrawn and commented that item that does not belong in NIST Handbook 44. NEWMA believes the consumer would be better served with comparisons or equivalents being made available through other sources more readily utilized by consumers (e.g., consumer websites or perhaps on new vehicle window stickers).

2013 Annual Meeting: CWMA recommended the item be withdrawn in consideration of comments made in opposition to the item during the 2013 Interim Meeting.

On the NCWM Online Position Forum one government representative indicated support; one government representative indicated a neutral position; and one government representative indicated opposition for this item. The neutral position was accompanied by a comment suggesting the establishment of a joint Task Group and encouraging a final recommendation that would clarify whether the proposed units are or are not permitted. The opposing position was accompanied by a comment indicating opposition to artificial units of measure.

Prior to the 2013 Annual Meeting, NCWM Chairman, Mr. Steve Benjamin, appointed the “NCWM Natural Gas Steering Committee,” which will be chaired by Mr. Mahesh Albuquerque (Colorado). The primary charge of the Committee is to educate the membership regarding: the technical issues surrounding this application; the rationale for the proposed changes; the anticipated impact of the proposed changes and issues related to their implementation. The Committee was asked to identify and address questions raised during the 2013 Interim Meeting as well as other venues in an effort to enable NCWM members to make informed decisions about proposals under consideration in this area.

Also prior to the 2013 Annual Meeting, the Committee received a proposal from Mr. Douglas Horne (Clean Vehicle Education Foundation) to modify the Item Under Consideration. Mr. Horne proposed separate definitions for CNG and LNG gallon equivalent values. The Committee suggested he work with the steering committee to further refine the proposal and suggest changes to the item as appropriate. Mr. Horne’s proposals will be posted on the NCWM website with other documents relative to the Committee’s final report. While submitted in an NCWM Form 15 template, Mr. Horne’s proposal is not addressing a new issue, but rather providing comments on a current item (Item 337-1) on the Committee’s agenda.

During its 2013 Annual Meeting Open Hearings, the Committee heard an update from Steering Committee Chairman, Mr. Albuquerque. He reported that the Steering Committee met for the first time on Sunday, July 14 at the beginning of the Annual and gathered input from those in the audience. Comments indicated that consumers

may find gallon equivalent information to be helpful, but the most equitable method for measuring and selling the product is based on mass measurement.

The S&T Committee heard overwhelming comments opposing the use of gallon equivalents and favoring the use of mass as the method of sale. The Committee also heard multiple comments indicating concern about the establishment of a value that would be an approximation of the actual equivalent for a given transaction. Mr. Horne reported that some states have already or are in the process of enacting defined “gasoline equivalent” values; some adopted earlier versions of the equivalent and some are considering new values as outlined in Mr. Horne’s most recent proposal.

Ms. Macey noted that the NCWM successfully adopted a method of sale for hydrogen fuel based on mass and suggested that the natural gas be held to the same standard. Mr. Keilty commented that sale of natural gas as a vehicle fuel has proliferated globally and those sales are based on mass units.

NIST, OWM acknowledged appreciation of the establishment of the Steering Committee to further study this issue. NIST, OWM encourages the S&T Committee, the Steering Committee, and the weights and measures community to consider the points raised by OWM during the 2013 Interim Meeting as well as the following in their deliberations of Items 337-1 and Item 337-2:

In addition to discussing the proposals in Items 337-1 and 337-2, OWM requests that the Task Group specifically discuss and consider whether or not the continued use of the terms “GLE” and “GGE” are appropriate for commercial CNG metering applications. NIST, OWM makes this request based on many of the same points made by OWM at the 2013 Interim Meeting and also given that:

1. this market is well established and consumer confidence and acceptance of CNG and other alternative fuels is not contingent upon continued comparisons with gasoline;
2. there are other methods for comparing relative efficiency and costs with gasoline;
3. experience with feedback from the community indicates problems with the application and validity of these units with changing gas supplies;
4. the proposal in Items 337-1 and 337-2 proposes language which would address natural gas as a whole and it is, therefore, appropriate to raise the discussion of whether or not the continued use of non-traceable units is appropriate. Additionally, OWM suggests that a proposal to eliminate the use of the terms “GLE” and “GGE” in favor of indications in mass units be developed and considered by the NCWM to ensure commercial transactions for natural gas are based on NIST traceable units of measure; and
5. as the number of viable alternative fuel options increase, providing a relatively static comparison with only one alternative fuel will not serve the broad needs of consumers and will make it unlikely that the dispenser is the appropriate location to provide comparison information.

The Committee also heard a comment from Mr. Karimov suggesting that volume units be permitted as a method of sale for LNG.

While many people expressed an understanding of the need for consumers to make comparisons with gasoline, comments indicate that such comparisons would typically be made prior to the purchase of a vehicle and possibly for a short time while becoming accustomed to the vehicle. The Committee heard comments indicating that weights and measures officials would be amenable to permitting the posting or displaying of supplemental information regarding gallon equivalent values.

Additional Contacts: Clean Energy, Seal Beach, CA, NGVAmerica, Washington, DC, Clean Vehicle Education Foundation, Acworth, GA

337-2 I S.1.2. Compressed Natural Gas Dispensers, S.1.3.1.1. Compressed Natural Gas Used as an Engine Fuel, S.5.2. Marking of Gasoline Volume Equivalent Conversion Factor

Source:

Clean Vehicle Education Foundation (2013)

Purpose:

Enable consumers to make cost and fuel economy comparisons between diesel fuel and natural gas.

Item Under Consideration:

Amend paragraphs S.1.2., S.1.3.1.1., and S.5.2. as follows:

S.1.2. Compressed–Natural Gas Dispensers. – Except for fleet sales and other price contract sales, a ~~compressed~~ natural gas dispenser used to refuel vehicles shall be of the computing type and shall indicate the quantity, the unit price, and the total price of each delivery. The dispenser shall display the mass measured for each transaction either continuously on an external or internal display accessible during the inspection and test of the dispenser, or display the quantity in mass units by using controls on the device.

(Added 1994)

S.1.3.1.1. Compressed–Natural Gas Used as an Engine Fuel. – When ~~compressed~~–natural gas is dispensed as an engine fuel, the delivered quantity shall be indicated in: ~~“gasoline liter equivalent (GLE) units” or “gasoline gallon equivalent (GGE) units” (see definitions).~~

(a) "gasoline liter equivalent (GLE) units" or gasoline gallon equivalent (GGE) units",

(b) "diesel liter equivalent (DLE) units" or "diesel gallon equivalent (DGE) units" (see definitions).

(Added 1994)

S.5.2. Marking of Diesel and Gasoline Volume Equivalent Conversion Factor. – A device dispensing ~~compressed~~–natural gas shall have: ~~either the statement “1 Gasoline Liter Equivalent (GLE) is Equal to 0.678 kg of Natural Gas” or “1 Gasoline Gallon Equivalent (GGE) is Equal to 5.660 lb of Natural Gas” permanently and conspicuously marked on the face of the dispenser according to the method of sale used.~~

(a) either the statement "1 Gasoline Liter Equivalent (GLE) is Equal to 0.678 kg of Natural Gas" or "1 Gasoline Gallon Equivalent (GGE) is Equal to 5.660 lb of Natural Gas",

(b) either the statement "1 Diesel Liter Equivalent (DLE) is Equal to 0.756 kg of Natural Gas" or "1 Diesel Gallon Equivalent (DGE) is Equal to 6.312 lb of Natural Gas" permanently and conspicuously marked on the face of the dispenser according to the method of sale used.

(Added 1994)

Background/Discussion:

The gasoline gallon equivalent (GGE) unit was defined by NIST/NCWM in 1994 (see Appendix A) to allow users of natural gas vehicles to readily compare costs and fuel economy of light-duty natural gas vehicles with equivalent gasoline powered vehicles. For the medium and heavy duty natural gas vehicles in widespread use today, there is a need to officially define a unit (already in widespread use) allowing a comparison of cost and fuel economy with diesel powered vehicles. Also natural gas is sold as a vehicle fuel as either Compressed Natural Gas (CNG) or Liquefied Natural Gas (LNG) and each method of sale in measure in mass. Therefore, the generic term “natural gas” is proposed to be used in NIST Handbooks 44 and 130 with out the existing term "compressed". The mathematics justifying the specific quantity (mass) of natural gas in a DLE and DGE is included in Appendix A.

The official definition of a DLE and a DGE will likely provide justification for California, Wisconsin, and any other state to permit retail sales of LNG for heavy-duty vehicles in these convenient units.

2012 CWMA Interim Meeting: The CWMA supported putting definitions of diesel liter equivalent and diesel gallon equivalent for natural gas into NIST Handbook 44, provided that FALS confirms the conversion factor prior to voting. CWMA forwarded the item to NCWM, recommending it as a Voting Item with this provision.

2012 NEWMA Interim Meeting: NEWMA recommended that this item be forwarded to the NCWM as an Informational Item and suggested it be assigned to the FALS.

2012 WWMA Annual Meeting: Ms. Williams (NIST Technical Advisor) advised that there is corresponding L&R Items 232-1 and 237-1 and S&T and L&R need to work on these items in tandem. The WWMA believed this item has merit. The WWMA has expressed concerns with the source of equivalency values derived and reported it would like validation as to whether the values accurately represent the actual value of various types of natural gas products. The WWMA realized there are different compositions and sources. For example, LNG has a higher methane composition. There may be a possibility of additional conversion factors based on BTUs from different sources. The WWMA S&T Committee met with the WWMA L&R Committee regarding this item, but differed on their recommendations regarding whether the status of the related items on their agendas should be Informational or Developmental. The WWMA forwarded this item to NCWM, recommending it as a Developing Item.

2012 SWMA Annual Meeting: Mr. Michael Keilty (Endress + Hauser) noted that there appears to be confusion about what the dispenser will display, particularly for dispensers that will serve vehicle types that run on gasoline as well as vehicle types that could run on diesel. He asked whether the units will display in both GLE/GGE and DLE/DGE and how the dispenser will display this information. He suggested that this item be designated as a “Developing” item to allow additional time to address these concerns. The SWMA reported that it did not believe that the proposal had been adequately developed with regard to the application of the proposed code changes, including aspects such as vetting of the referenced values within the industry with relative to actual gas supplies; explanation of how these requirements will be applied consistently; and provisions for ensuring clear and understandable value comparisons by consumers (particularly given variations in gas supplies); and how this will apply to dispensers that may be used to fuel vehicles conventionally fueled by gasoline or diesel. The Committee questioned whether it might be more appropriate for the community to consider establishing mass as the method of sale for natural gas and providing educational information through mechanisms such as pump toppers that would enable the consumer to compare the fuel costs with gasoline or diesel powered vehicles. This approach would eliminate concerns about designating equivalent values that may not accurately represent the product being sold through a specific dispenser. SWMA unanimously agreed to forward the item to NCWM, recommending it as a Developing Item with development assigned to the submitter.

2013 NCWM Interim Meeting: the Committee heard comments from Mr. Keilty who expressed concern about the adoption of the proposed equivalent value as a unit of measure. He noted that the intent of this item is not to allow the user to toggle between mass units and equivalent units at the push of a button. He also noted that, if the units are set as “DLE” or “DGE,” the customer cannot also view units in “GLE” or “GGE.” Mr. Karimov (Liquid Controls Corporation, LLC), indicated opposition to the proposal to strike the work “compressed.” Ms. Williams referenced NIST, OWM’s comments made in association with Agenda Item 337-1 and suggested that the Committee consider those same comments in their deliberations of this item.

The Committee heard no comments in support of the proposal during its Open Hearings. See Item 337-1 for details regarding the S&T Committee’s collaborations with the NCWM L&R Committee on Items 337-1 and 337-2 on the S&T Committee’s agenda and Items 232-1 and 237-1 on the L&R Committee’s agenda.

2013 NEWMA Annual Meeting: It was recommended the item be Withdrawn and commented that item that does not belong in NIST Handbook 44. NEWMA believes the consumer would be better served with comparisons or equivalents being made available through other sources more readily utilized by consumers (e.g., consumer websites or perhaps on new vehicle window stickers).

2013 CWMA Annual Meeting: The CWMA recommended the item be withdrawn in consideration of comments made in opposition to the item during the 2013 Interim Meeting.

On the NCWM Online Position Forum, two government representatives indicated a neutral position and one government representative indicated opposition for this item. The neutral position was accompanied by a comment suggesting the establishment of a Joint Task Group and encouraging a final recommendation that would clarify whether the proposed units are or are not permitted. The opposing position was accompanied by a comment indicating opposition to artificial units of measure and noting that establishment of DGE and DLE values perpetuate the use of artificial units.

2013 NCWM Annual Meeting: The Committee heard comments on Item 337-1 and Item 337-2 jointly. Details of comments are included in Item 337-1.

Additional Contacts: Clean Energy, Seal Beach, California, NGVAmerica, Washington, DC, Clean Vehicle Education Foundation, Acworth, Georgia.

337-3 VC Table T.2. Accuracy Classes and Tolerances for Mass Flow Meters

(This item was adopted.)

Source:

NIST, Office of Weights and Measures (2013)

Purpose:

Resolve inconsistencies in the temperature ranges defined for Heated Products among NIST Handbook 44, Liquid-Measuring Devices, Vehicle Tank-Meters, and Mass Flow Meters Codes.

Item Under Consideration:

Amend Table T.2. as follows:

Accuracy Class	Application or Commodity Being Measured	Acceptance Tolerance	Maintenance Tolerance	Special Tolerance
0.3	<ul style="list-style-type: none"> - Large capacity motor-fuel dispensers (maximum discharge flow rates greater than 100 L/min or 25 gal/min) - Heated products <u>(other than asphalt) equal to temperatures greater than 50 °C (122 °F)</u> - Asphalt <u>at temperatures</u> at or below a <u>temperature of 50 °C (122 °F)</u> - Loading rack meters - Vehicle-tank meters - Home heating oil - Asphalt at or below 50 °C - Milk and other food products - All other liquid applications not shown in the table where the minimum delivery is at least 700 kg (1500 lb) 	0.2 %	0.3 %	0.5 %
0.3A	<ul style="list-style-type: none"> - Asphalt at temperatures greater than 50 °C <u>(122 °F)</u> 	0.3 %	0.3 %	0.5 %
0.5	<ul style="list-style-type: none"> - Small capacity (retail) motor-fuel dispensers - Agri-chemical liquids - All other liquid applications not shown in the table where the minimum delivery is less than 700 kg or 1500 lb 	0.3 %	0.5 %	0.5 %
1.0	<ul style="list-style-type: none"> - Anhydrous ammonia - LP Gas (including vehicle-tank meters) 	0.6 %	1.0 %	1.0 %
2.0	<ul style="list-style-type: none"> - Compressed natural gas as a motor-fuel 	1.5 %	2.0 %	2.0 %
2.5	<ul style="list-style-type: none"> - Cryogenic liquid meters - Liquefied compressed gases other than LP Gas 	1.5 %	2.5 %	2.5 %

(Added 1994) (Amended 1999, ~~and~~ 2001 and 2013)

Background/Discussion:

This item was initiated as a result of discussions at an NTEP measuring labs meeting and forwarded to the Measuring Sector for review in 2011. In reviewing criteria for heated products during discussions at the 2011 annual NTEP Laboratory Meeting, the Measuring Laboratories noted inconsistencies in the way that heated products are referenced in the LMD, VTM, and MFM Codes.

The differentiation between “heated” and “non-heated” products first appeared in NIST Handbook 44 in 2000 as a result of a proposal adopted by the NCWM in 1999 to expand the tolerances applicable to meters used to measure asphalt above 50 °C (see S&T Committee Items 330-6 and 337-4 in the 1999 NCWM S&T Committee Final Report for details). This reference was refined by the Committee in 2001 when changes were adopted to clarify the application of tolerances to asphalt at 50 °C in the LMD and MFM Codes. When the LMD and VTM Codes were modified in 2003 and 2004 to adopt an accuracy class table to mirror the MFM Code, inconsistencies first appeared in the way that heated products were referenced among the codes.

This proposal, and similar proposals elsewhere in the Committee’s agenda, suggests changes to correct these inconsistencies. A summary of the proposals is listed below.

Section: 3.30 Liquid-Measuring Devices; Table T.2. (S&T Item 330-2)

Section: 3.31 Vehicle-Tank Meters; Table 1. (S&T Item 331-1)

Section: 3.37 Mass Flow Meters; Table T.2. (S&T Item 337-3)

NIST, OWM notes that there may also be a need to address hot water meters (for which the American Water Works Association (AWWA) defines a boundary temperature of 90 °F) in NIST Handbook 44.

The proposed changes in these items take into account corresponding references to heated products in NCWM Publication 14, including the “Product Families Table” in Technical Policy C and past discussions at meetings of the NTEP Measuring Sector. Revisions are also proposed to ensure appropriate references to both Fahrenheit and Celsius temperatures.

2012 NEWMA and SWMA Annual Meeting: The associations supported moving this item forward as a Voting Item. The SWMA also recommended that this item be consolidated with correlating items in the VTM and MFM during the voting process to help ensure consistency among these codes.

2013 NCWM Interim Meeting: The Committee received comments in writing from NIST, OWM as outlined in Item 330-2 and heard a synopsis of these comments from Ms. Juana Williams (NIST, OWM) during the Open Hearings. Hearing no opposition to the proposed changes, the Committee agreed to move this item forward for a Vote.

2013 NEWMA and the CWMA Annual Meetings: The associations supported the designation of this item as a Voting Item and agreed with the need to resolve current inconsistencies. Three government representatives indicated support and one government representative indicated a neutral position for this item on the NCWM Online Position Forum with no additional comments.

2013 NCWM Annual Meeting: The Committee took comments on this item simultaneously with Items 330-2 and 331-1. See Item 330-2 for additional details.

354 TAXIMETERS

354-1 D Global Positioning Systems for Taximeters

Note: At the 2013 NCWM Interim Meeting, the Committee considered a proposal to amend Section 5.54. in NIST Handbook 44 to make it specifically apply to Global Positioning System (GPS) system applications used commercially to compute fares based upon distance and/or time measurements. There was no specific language proposed for consideration. That item (Item 354-1) has been combined with 2013 Agenda “Item 360-5, S.5. Provision for Security Seals” and “Item 360-6 Global Positioning Systems for Taximeters” to create a new, consolidated Developing Item. The consolidated Developing Item is designated as “Item 360-5 titled “USNWG on Taximeters – Taximeter Code Revisions and Global Positioning Systems for Time and Distance Measurement.” See Item 360-5 for details.

356 GRAIN MOISTURE METERS

356-1 VC Table S.2.5. Categories of Device and Methods of Sealing

(This item was adopted.)

Source:

NTEP Grain Analyzer Sector (2013)

Purpose:

Clarify that the requirements of Category 3 apply whether accessed manually using the keyboard or accessed by remote means, and that these requirements apply to all the subcategories of Category 3.

Item Under Consideration:

Amend Table S.2.5. as follows:

Table S.2.5. Categories of Device and Methods of Sealing	
Categories of Device	Methods of Sealing
Category 1: <i>No remote configuration capability.</i>	<i>Seal by physical seal or two event counters: one for calibration parameters (000 to 999) and one for configuration parameters (000 to 999). If equipped with event counters, the device must be capable of displaying, or printing through the device or through another on-site device, the contents of the counters.</i>
Category 2: <i>Remote configuration capability, but access is controlled by physical hardware.</i> <i>A device shall clearly indicate that it is in the remote configuration mode and shall not be capable of operating in the measure mode while enabled for remote configuration.</i>	<i>The hardware enabling access for remote communication must be at the device and sealed using a physical seal or two event counters: one for calibration parameters (000 to 999) and one for configuration parameters (000 to 999). If equipped with event counters, the device must be capable of displaying, or printing through the device or through another on-site device, the contents of the counters.</i>
Category 3: <i>Remote configuration capability access may be unlimited or controlled through a software switch (e.g., password).</i> <i>When accessed remotely for the purpose of modifying sealable parameters, the device shall clearly indicate that it is in the configuration mode and shall not be capable of operating in the measuring mode.</i>	<i>An event logger is required in the device; it must include an event counter (000 to 999), the parameter ID, the date and time of the change, and the new value of the parameter (for calibration changes consisting of multiple constants, the calibration version number may be used rather than the calibration constants). A printed copy of the information must be available through the device or through another on-site device. The event logger shall have a capacity to retain records equal to twenty-five (25) times the number of sealable parameters in the device, but not more than 1000 records are required. (Note: Does not require 1000 changes to be stored for each parameter.)</i>

Table S.2.5. Categories of Device and Methods of Sealing	
Categories of Device	Methods of Sealing
<p>Category 3a: No remote capability, but operator is able to make changes that affect the metrological integrity of the device (e.g., slope, bias, etc.) in normal operation.</p> <p><u>*When accessed for the purpose of modifying sealable parameters, the device shall clearly indicate that it is in the configuration mode and shall not be capable of operating in the measuring mode.</u></p>	Same as Category 3
<p>Category 3b: No remote capability, but access to metrological parameters is controlled through a software switch (e.g., password).</p> <p><u>*When accessed for the purpose of modifying sealable parameters, the device shall clearly indicate that it is in the configuration mode and shall not be capable of operating in the measuring mode.</u></p>	Same as Category 3

[Nonretroactive as of January 1, 1999 **and** *January 1, 2014]

Background/Discussion:

All of the grain moisture meters (GMMs) in Categories 3, 3a, and 3b of Table S.2.5. use an electronic method of sealing, and most of them also offer access to the configuration mode through a keyboard entered password. In this mode, sealable parameters can also be changed locally through the keyboard. Category 3 of Table S.2.5. currently includes the following requirement:

When accessed remotely for the purpose of modifying sealable parameters, the device shall clearly indicate that it is in the configuration mode and shall not be capable of operating in the measuring mode.

At its 2011 Grain Analyzer Sector Meeting the Sector agreed that the following changes to Table S.2.5. of §5.56.(a) of NIST Handbook 44 should be forwarded to the S&T Committee for consideration:

- Add a note to Table S.2.5. to recognize the expanded scope of remote capability.
- Delete “remotely” from the second paragraph of Category 3 requirements that begins, “When accessed remotely ...” to make it clear that the requirements of Category 3 apply whether accessed manually using the keyboard or accessed by remote means.
- Add the modified second paragraph of Category 3 requirements to Categories 3a and 3b to make it clear that these requirements apply to all the subcategories of Category 3.

After additional review of this item, NIST, OWM recommended that the changes to Table S.2.5. approved by the Sector in 2011 be separated into two independent proposals, one dealing with the changes to Category 3 and its subcategories (as shown in this proposal), and the other recommending a modification of the definition of remote configuration capability appearing in Appendix D of NIST Handbook 44 to recognize the expanded scope of remote capability, instead of adding a note to the bottom of Table S.2.5. to expand the definition of remote configuration for grain moisture meters. A change to the definition of remote configuration capability will apply to other device types.

2012 Grain Analyzer Sector Meeting: The Sector agreed to separate its original proposal into two separate proposals and that the following changes to Table S.2.5. of §5.56.(a) of NIST Handbook 44 should be forwarded to the S&T Committee for consideration:

- Delete “remotely” from the second paragraph of Category 3 requirements that begins, “When accessed remotely ...” to make it clear that the requirements of Category 3 apply whether accessed manually using the keyboard or accessed by remote means.
- Add the modified second paragraph of Category 3 requirements to Categories 3a and 3b to make it clear that these requirements apply to all the subcategories of Category 3.

This proposal is consistent with the philosophy of sealing for grain moisture meters. Item 4 of the NTEP, Grain Analyzer Sector August 2012 Meeting Summary covers this subject and will be available on NCWM’s Website November 2012.

2012 CWMA Interim Meeting: CWMA forwarded the item to NCWM, recommending it as a Voting Item.

2012 WWMA Annual Meeting: Ms. Juana Williams (NIST, OWM) expressed general support for the intent of this item; that the device should indicate when it is in configuration mode and not be capable of operating in the measuring mode. The Committee acknowledged the proposed recommendation from the NTEP Grain Analyzer Sector to add a note to Table S.2.5. to expand the scope of remote capability by modifying its definition for remote configuration capability as shown in S&T Item 356-3. The Committee did not support that item. WWMA forwarded this item to NCWM, recommending it as a Voting Item.

2012 SWMA Annual Meeting: There were no comments. The Committee acknowledged that the proposal is supported by the NTEP Grain Sectors. Recognizing the expertise of the Sector members, the Committee believed it is appropriate to support the proposal as recommended by the Work Group. SWMA forwarded the item to NCWM, recommending it as a Voting Item.

2013 NCWM Interim Meeting Open Hearings: The Committee heard comments from Ms. Williams (NIST, OWM) who noted that OWM agrees with the Sector’s decision to separate their original proposal into two parts. OWM also agreed with the elimination of the note originally proposed for Table S.2.5. OWM also believes the proposed change to require Category 3 devices, including these classified as subcategories 3a and 3b devices clearly indicate when they are in the configuration mode and not be capable of operating in the measuring mode is appropriate. These proposed changes are generally consistent with the sealing requirements for all similar tables in Section 3 of NIST Handbook 44. The Committee may wish to consider proposing similar changes where appropriate in other NIST Handbook 44 device codes. The Committee heard no other comments on this item. Hearing no opposition to the proposed changes, the Committee agreed to recommend the proposal for a Vote.

2013 Annual Meetings of NEWMA and the CWMA: The associations supported this item as a Voting Item. On the NCWM Online Position Forum, one government representative supported the proposal, with no additional comments.

2013 NCWM Annual Meeting Open Hearings: The Committee heard no comments in opposition to this item. NIST, OWM reiterated its comments from the 2013 Interim Meeting.

356-2 VC UR.3.4. Printed Tickets

(This item was adopted.)

Source:

Grain and Feed Association of Illinois (2012)

Purpose:

Change the mandatory printing of tickets from grain moisture meters to an on demand at the time of transaction printing and remove the requirement of printing the calibration version identification. Note that the Committee did not agree with proposed removal of the requirement to print the calibration version identification; this position is reflected in the version of the proposal currently under consideration by the Committee.

Item Under Consideration:

Amend paragraph UR.3.4. as follows:

UR.3.4. Printed Tickets.

- (a) Printed tickets shall be free from any previous indication of moisture content or type of grain or seed selected.
- (b) The customer shall be given a printed ticket **at the time of the transaction or as otherwise specified by the customer. The printed ticket shall include showing** the date, grain type, grain moisture results, test weight per bushel, and calibration version identification. The ticket **information** shall be generated by the grain moisture meter system.

(Amended 1993, 1995, ~~and~~ 2003, **and 2013**)

Background/Discussion:

According to the submitter, the user requirement to provide a printed ticket for every single load is unrealistic in the country elevator industry. Traffic patterns at country elevators do not lend themselves to providing a printed ticket to all customers and customers really don't want them. As the speed and capacity increases in the industry, outbound scales are being located at a distance from the inbound scale and the scale house where the moisture tester is located to alleviate traffic bottlenecks. When the outbound scale is located away from where the ticket is printed, the truck driver must circle back around to pick up the ticket, thus, causing logistical problems. In addition, since meters are sealed, inspected, and required to have the correct calibration, there is no need for the calibration version identification to be printed on the ticket. Also, most customers are not going to know if it is the correct calibration version identification or not. There have been problems getting the information from the grain moisture meter to the grain accounting system – especially the calibration version identification. Some grain accounting systems have to be “hard coded” for calibration version identification which must be changed whenever the calibration changes. The change will be at an added cost for the industry.

When a consumer pays at a gas pump, they have the option of a receipt on demand at the time of transaction or not receiving a receipt. There would be a cost savings to moisture meter users as they would save on paper and filing space, and in the situation where the calibration version identification is “hard coded,” there will be a cost savings of the expense to have the grain accounting software provider make those changes.

Since moisture meters are capable of printing the ticket, some would argue that they should just go ahead and print them and provide them to the customer. In addition, the requirement does not say when the ticket shall be given to the customer; thus, the printed tickets could be saved for weeks, months, or even years in case the customer had a concern at some point. Printing the calibration version identification ensures the correct calibration is being used.

The submitter proposed amendments to paragraph UR.3.4. Printed Tickets which would allow the customer to dictate whether or not a printed ticket is needed for a given transaction but would not require printing of the calibration version identification on the ticket. In 2011 and 2012, the Committee received comments supporting changes to the language that would allow the customer to specify whether or not he or she wanted a printed ticket.

However, the Committee heard opposition from the NTETC Grain Sector and others to deleting the calibration version information from the ticket. Consequently, the proposal was revised to maintain the reference to calibration version information as shown in the Item Under Consideration. Additional details can be found in the Committee's 2011 and 2012 Final Reports.

2012 CWMA Interim Meeting: It was recommended that the item be Withdrawn; however, the association supported the item as a Voting Item at its 2013 Annual Meeting.

2012 WWMA Annual Meeting: The association received no comments on this item. The WWMA believed the intent in the amended proposed language is similar to other codes in NIST Handbook 44 and sufficiently gives options of how printed tickets are provided to the customer. WWMA supported the item and recommended that it be a Voting Item.

2012 NEWMA Interim Meeting and 2013 Annual Meeting: NEWMA supported this item as a Voting Item at both meetings.

2012 SWMA Annual Meeting: The SWMA received no comments. The Committee recognized that the NCWM S&T Committee designated this as an Information Item to allow additional time for the weights and measures community, including the original submitter, to review the changes made to the proposal during the 2012 NCWM Interim Meeting. The Committee believes that adequate time has elapsed to allow for comment. The Committee noted that the NTEP Grain Analyzer Sector has also reviewed the proposal, as modified, and has expressed no opposition. SWMA recommended that the item be a Voting Item.

2013 NCWM Interim Meeting Open Hearings: The Committee heard comments from Ms. Juana Williams (NIST, OWM) who noted that OWM believes the suggested changes to UR.3.4. Printed Tickets are appropriate and notes that the language is similar to other codes in NIST Handbook 44. OWM agrees with the Grain Analyzer Sector's decision to retain the requirement for recording the "calibration version identification." NIST, OWM noted that while "Category 3" devices would require the printing of the calibration version identification information, not all grain moisture meters are "Category 3" devices. Having this information printed on receipts provides customers and officials with the means to verify that correct calibration settings are being used for a given transaction. The Committee received no other comments on this item. Hearing no opposition to the proposed changes, the Committee agreed to recommend the proposal for a Vote.

On the 2013 NCWM Online Position Forum, one government representative opposed the proposal, with no additional comments.

2013 NCWM Annual Meeting Open Hearings: The Committee heard no comments in opposition to this item. NIST, OWM reiterated its comments from the 2013 Interim Meeting.

356-3 D Appendix D – Definitions: Remote Configuration Capability

Note: Following deliberations at the NCWM 2013 Interim Meeting, the Committee designated this item as a Developing Item. It has been moved to the Developing Items section of the agenda and designated as Item 360-7.

360 OTHER ITEMS – DEVELOPING ITEMS

360-1 D International Organization of Legal Metrology (OIML) Report

Many issues before the OIML, the Asian-Pacific Legal Metrology Forum, and other international groups are within the purview of the Committee. Additional information on OIML activities will appear in the NCWM Board of Directors agenda, interim and final meeting reports, and on the OIML website at www.oiml.org. NIST, OWM staff will provide the latest updates on OIML activities during the Open Hearings at NCWM meetings. For more

information on specific OIML related device activities, contact the NIST, OWM staff listed in the table below. The list below of OIML projects only represents active projects.

NIST Office of Weights and Measures Staff Contact List for International Activities	
Contact Information	Responsibilities
Mr. John Barton – LMDP Phone: (301) 975-4002 Email: john.barton@nist.gov	<ul style="list-style-type: none"> • R 21 <i>Taximeters</i> • R 50 <i>Continuous Totalizing Automatic Weighing Instruments (Belt Weighers)</i> • R 60 <i>Metrological Regulations for Load Cells</i> • R 106 <i>Automatic Rail-weighbridges</i>
Mr. Kenneth Butcher – LMP Phone: (301) 975-4859 Email: k.butcher@nist.gov	<ul style="list-style-type: none"> • TC 6 <i>Prepackaged Products</i>
Dr. Charles Ehrlich – ILMP Phone : (301) 975-4834 Email : charles.ehrlich@nist.gov	<ul style="list-style-type: none"> • International Committee of Legal Metrology Member for the U.S. • V1 <i>International Vocabulary of Terms in Legal Metrology</i> • V2 <i>International Vocabulary of Basic and General Terms in Metrology</i> • B 3 <i>OIML Certificate System for Measuring Instruments</i> • B 6 <i>OIML Directives for the Technical Work</i> • B 10 <i>Framework for a Mutual Acceptance Arrangement on OIML Type Evaluations</i> • TC 3/SC 5 <i>Expression of Uncertainty in Measurement in Legal Metrology Applications, Guidelines for the Application of ISO/IEC 17025 to the Assessment of Laboratories Performing Type Evaluation Tests</i> • TC 3 <i>Metrological Control</i> • ISO/IEC <i>Guide to the Expression of Uncertainty in Measurement</i>
Mr. Richard Harshman – LMDP Phone: (301) 975-8107 Email: richard.harshman@nist.gov	<ul style="list-style-type: none"> • R 51 <i>Automatic Catchweighing Instruments</i> • R 61 <i>Automatic Gravimetric Filling Instruments</i> • R 76 <i>Non-automatic Weighing Instruments</i> • R 107 <i>Discontinuous Totalizing Automatic Weighing Instruments (totalizing hopper weighers)</i> • R 134 <i>Automatic Instruments for Weighing Road Vehicles In-Motion and Measuring Axle Loads</i>
Ms. Diane Lee – LMDP Phone: (301) 975-4405 Email: diane.lee@nist.gov	<ul style="list-style-type: none"> • R 59 <i>Moisture Meters for Cereal Grains and Oilseeds</i> • R 92 <i>Wood Moisture Meters – Verification Methods and Equipment</i> • TC 17/SC 8 <i>Protein Measuring Instruments for Cereal Grains and Oil Seeds</i>
Mr. Ralph Richter – ILMP Phone: (301) 975-3997 Email: ralph.richter@nist.gov	<ul style="list-style-type: none"> • D 11 <i>General Requirements for Measuring Instruments – Environmental Conditions</i> • R 35 <i>Material Measures of Length for General Use</i> • R 49 <i>Water Meters (Cold Potable Water and Hot Water Meters)</i> • R 71 <i>Fixed Storage Tanks</i> • R 80 <i>Road and Rail Tankers (static measurement)</i> • R 85 <i>Automatic Level Gauges for Measuring the Level of Liquid in Fixed Storage Tanks</i> • R 95 <i>Ship’s Tanks</i> • R 117 <i>Measuring Systems for Liquids Other Than Water (all measuring technologies)</i> • R 118 <i>Testing Procedures and Test Report Format for Pattern</i>

	<p><i>Examination of Fuel Dispensers for Motor Vehicles</i></p> <ul style="list-style-type: none"> • TC 3/SC 4 <i>Verification Period of Utility Meters Using Sampling Inspections</i> • R 137 <i>Gas Meters</i> (all measuring technologies) • R 140 <i>Measuring Systems for Gaseous Fuel</i> (i.e., large pipelines) • ISO TC 30/SC 7 <i>Water Meters</i>
<p>Dr. Ambler Thompson – ILMP Phone: (301) 975-2333 Email: ambler@nist.gov</p>	<ul style="list-style-type: none"> • V1 <i>International Vocabulary of Terms in Legal Metrology</i> • D 16 <i>Principles of Assurance of Metrological Control</i> • D 19 <i>Pattern Evaluation and Pattern Approval</i> • D 20 <i>Initial and Subsequent Verification of Measuring Instruments and Processes</i> • D 27 <i>Initial Verification of Measuring Instruments Using the Manufacturer’s Quality Management System</i> • D 31 <i>General Requirements for Software Controlled Measuring Instruments</i> • R 34 <i>Accuracy Classes of Measuring Instruments</i> • R 46 <i>Active Electrical Energy Meters for Direct Connection of Class 2</i>
<p>Ms. Juana Williams – LMDP Phone: (301) 975-3989 Email: juana.williams@nist.gov</p>	<ul style="list-style-type: none"> • R 81 <i>Dynamic Measuring Devices and Systems for Cryogenic Liquids</i> • R 139 <i>Compressed Gaseous Fuels Measuring Systems for Vehicles</i>
List of Acronyms	
B Basic Publication	LMDP Legal Metrology Devices Program
CIML International Committee of Legal Metrology	P Project
D Document	R Recommendation
ILMP International Legal Metrology Program	SC Subcommittee
LMP Laws and Metrics Program	TC Technical Committee

The WWMA and the SWMA support these issues and the related device activities as an Informational Item. At the 2012 NEWMA Interim Meeting it was noted that Dr. Charles Ehrlich (NIST, OWM) does a great job at annual and interim meetings explaining OIML issues. NEWMA supports the efforts of NIST to harmonize with OIML wherever possible to create a marketplace that reflects the global marketplace of today.

2012 WWMA Annual Meeting: M s. Carol Hockert (NIST, OWM) reported that OIML will be meeting in Bucharest, Romania, in October of 2012. The Committee looks forward to any future report updates following this meeting. WWMA recommended that the item remain as a Developing Item.

2012 SWMA Annual Meeting: SWMA unanimously recommended that the item remain as a Developing Item.

Contact Point: See contacts listed in the table above for specific technical areas.

360-2 D G-S.1. Identification. – (Software)

Source:

This item originated from the NTEP Software Sector and first appeared on NCWM S&T Committee’s 2007 agenda as Developing Item Part 1, Item 1 and in 2010 as Item 310-3.

Purpose:

Provide marking requirements that enable field verification of the appropriate version or revision for metrological software, including methods other than “permanently marked,” for providing the required information.

Item Under Consideration:

Amend NIST Handbook 44: G S.1. Identification and G S.1.1. Location of Marking Information for Not-Built-for-Purpose, Software-Based Devices as follows:

G-S.1. Identification. – All equipment, except weights, ~~and~~ separate parts necessary to the measurement process but not having any metrological effect, and software-based devices covered in G-S.1.1. Location of Marking Information*, shall be clearly and permanently marked for the purposes of identification with the following information:

[*Nonretroactive as of January 1, 20XX]

(Amended 20XX)

- (a) the name, initials, or trademark of the manufacturer or distributor;
- (b) a model identifier that positively identifies the pattern or design of the device;
 - (1) *The model identifier shall be prefaced by the word “Model,” “Type,” or “Pattern.” These terms may be followed by the word “Number” or an abbreviation of that word. The abbreviation for the word “Number” shall, as a minimum, begin with the letter “N” (e.g., No or No.). The abbreviation for the word “Model” shall be “Mod” or “Mod.” Prefix lettering may be initial capitals, all capitals, or all lowercase.*
 [Nonretroactive as of January 1, 2003]
 (Added 2000) (Amended 2001)
- (c) *a non-repetitive serial number, except for equipment with no moving or electronic component parts ~~and not built for purpose software-based software device;~~*
 [Nonretroactive as of January 1, 1968]
 (Amended 2003 and 20XX)
 - (1) *The serial number shall be prefaced by words, an abbreviation, or a symbol, that clearly identifies the number as the required serial number.*
 [Nonretroactive as of January 1, 1986]
 - (2) *Abbreviations for the word “Serial” shall, as a minimum, begin with the letter “S,” and abbreviations for the word “Number” shall, as a minimum, begin with the letter “N” (e.g., S/N, SN, Ser. No., and S. No.).*
 [Nonretroactive as of January 1, 2001]
- (c) *the current software version or revision identifier for ~~not built for purpose~~ software-based electronic devices;*
 [Nonretroactive as of January 1, 2004]
 (Added 2003) (Amended 20XX)
 - (1) *The version or revision identifier shall be prefaced by words, an abbreviation, or a symbol, that clearly identifies the number as the required version or revision.*
 [Nonretroactive as of January 1, 2007]
 (Added 2006)
 - (2) *Abbreviations for the word “Version” shall, as a minimum, begin with the letter “V” and may be followed by the word “Number.” Abbreviations for the word “Revision” shall, as a minimum, begin with the letter “R” and may be followed by the word “Number.” The abbreviation for the word “Number” shall, as a minimum, begin with the letter “N” (e.g., No or No.).*
 [Nonretroactive as of January 1, 2007]
 (Added 2006)

- (e) *an NTEP CC number or a corresponding CC Addendum Number for devices that have a CC. The CC Number or a corresponding CC Addendum Number shall be prefaced by the terms “NTEP CC,” “CC,” or “Approval.” These terms may be followed by the word “Number” or an abbreviation of that word. The abbreviation for the word “Number” shall, as a minimum, begin with the letter “N” (e.g., No or No.)*
[Nonretroactive as of January 1, 2003]

The required information shall be so located that it is readily observable without the necessity of the disassembly of a part requiring the use of any means separate from the device.
(Amended 1985, 1991, 1999, 2000, 2001, 2003, ~~and~~, 2006, ~~and~~ **20XX**)

G-S.1.1. Location of Marking Information for ~~Not-Built-For-Purpose~~ all Software-Based Devices. –
For ~~not-built-for-purpose~~, software-based devices, either:

- (a) *The required information in G S.1. Identification. ~~(a), (b), (d), and (e)~~ shall be permanently marked or continuously displayed on the device; or*
- (b) *The Certificate of Conformance (CC) Number shall be:*
- (1) *permanently marked on the device;*
- (2) *continuously displayed; or*
- (3) *accessible through ~~an easily recognized menu and, if necessary, a submenu. Examples of menu and submenu identification include, but are not limited to, “Help,” “System Identification,” “G S.1. Identification,” or “Weights and Measures Identification.”~~ one or, at most, two levels of access.*
- (i) *For menu based systems, “Metrology,” “System Identification,” or “Help.”*
- (ii) *For systems using icons, a metrology symbol “(M)”, “(SI),” or a help symbol (“?”, “i,” or an “i” within a magnifying glass).*

Note: *For (b), clear instructions for accessing the information required in G S.1. (a), (b), and (d) shall be listed on the CC, including information necessary to identify that the software in the device is the same type that was evaluated.*

[Nonretroactive as of January 1, 2004]

(Added 2003) (Amended 2006 ~~and~~ **20XX**)

Background/Discussion:

Among other tasks, the NTEP Software Sector was charged by the NCWM Board of Directors to recommend NIST Handbook 44 specifications and requirements for software incorporated into weighing and measuring devices, which may include tools used for software identification. During its October 2007 meeting, the Sector discussed the value and merits of required markings for software, including possible differences in some types of software-based devices and methods of marking requirements. After hearing several proposals, the Sector agreed to the following technical requirements applicable to the marking of software:

1. The NTEP CC Number must be continuously displayed or hard-marked;
2. The version must be software-generated and shall not be hard-marked;
3. The version is required for embedded (Type P) software;
4. Printing the required identification information can be an option;

5. Command or operator action can be considered as an option in lieu of a continuous display of the required information; and
6. Devices with Type P (embedded) software must display or hard-mark the device make, model, and serial number to comply with G S.1. Identification.

In 2008, the Software Sector developed and submitted a proposal to the NCWM S&T Committee to modify G-S.1. and associated paragraphs to reflect these technical requirements. Between 2008 and 2011, this item appeared on the S&T Committee's main agenda and the Committee and the Sector received numerous comments and suggestions relative to the proposal. The Sector developed and presented several alternatives based on feedback from weights and measures officials and manufacturers. Among the key points and concerns raised during discussions over this period were how to address the following:

1. **Limited Character Sets and Space.** – How to address devices that have limited character sets or restricted space for marking.
2. **Built-for-Purpose vs. Not-Built-for-Purpose.** - Whether or not these should be treated differently.
3. **Ease of Access.** – Ease of accessing marking information in the field.
 - Complexity of locating the marking information
 - Use of menus for accessing the marking information electronically
 - Limits on the number of levels required to access information electronically
 - Possibility of single, uniform method of access
4. **Hard Marking vs. Electronic.** – Whether or not some information should be required to be hard marked on the device.
5. **Continuous Display.** – Whether or not required markings must be continuously displayed.
6. **Abbreviations and Icons.** – Establishment of unique abbreviations, identifiers, and icons and how to codify those.
7. **Certificate of Conformance Information.** – How to facilitate correlation of software version information to a CC, including the use of possible icons.

Further details on the alternatives considered can be found in the Committee's Final Reports from 2008 to 2011.

2011 NCWM Interim Meeting: The S&T Committee concurred with the Software Sector Chair that this item is not ready to move forward as a Voting Item. The Committee recommended the Sector review a number of specific comments and points (see the Committee's 2011 Final Report for details.)

2011 NCWM Annual Meeting: The Committee heard support for the continued work of the Sector. The 2011 S&T Committee designated this item as a Developing Item to provide the Software Sector additional time to more fully develop the item. The Committee looked forward to considering the Sector's future recommendations.

2011 fall Regional Meetings: The regional weights and measures associations noted the importance of this work. All regional associations recommended that the item remain as a Developing Item to allow the Sector to further develop the issue. The regional associations also reported a desire to receive an update on the progress of the Software Sector regarding this item. Three of the regions recommended the item remain Developing. NEWMA recommended the item be Withdrawn unless new information is introduced.

2013 NCWM Interim Meeting: No comments were received relative to this item during the Open Hearings. In considering the item, the Committee questioned whether or not the Software Sector was still actively working the item. It was reported that the Software Sector believed they had developed the item as much as possible, yet the different stakeholders affected by the proposal could not agree on the changes that the Sector had proposed. Based

upon that update, the Committee agreed to add to its report a request that the Software Sector work with the Weighing Sector and Measuring Sector to identify which portions of the proposal need to be modified in order that they might be accepted by the entire community. The Committee acknowledges and appreciates the efforts of the Software Sector and looks forward to being able to consider a proposal that addresses both the identification of software and how it may be accessed.

The following draft update from the Software Sector regarding this item was forwarded to the Committee just prior to the 2013 NCWM Annual Meeting:

Software Sector Meeting - March 2013: The Sector considers this item sufficiently developed. During the 2013 Meeting, the Sector agreed to modify slightly the previously language to address some of the concerns received via feedback from other sectors and interested parties. The following changes to that language are proposed:

NIST Handbook 44 – Proposed changes:

G-S.1. Identification. – All equipment, except weights and separate parts necessary to the measurement process but not having any metrological effect, shall be clearly and permanently marked for the purposes of identification with the following information:

- (a) the name, initials, or trademark of the manufacturer or distributor;
- (b) a model identifier that positively identifies the pattern or design of the device;
 - (1) *The model identifier shall be prefaced by the word “Model,” “Type,” or “Pattern.” These terms may be followed by the word “Number” or an abbreviation of that word. The abbreviation for the word “Number” shall, as a minimum, begin with the letter “N” (e.g., No or No.). The abbreviation for the word “Model” shall be “Mod” or “Mod.” Prefix lettering may be initial capitals, all capitals, or all lowercase.*
[Nonretroactive as of January 1, 2003]
(Added 2000) (Amended 2001)
- (c) *a nonrepetitive serial number, except for equipment with no moving or electronic component parts and ~~not built for purpose software-based software devices~~ software;*
[Nonretroactive as of January 1, 1968]
(Amended 2003)
 - (1) *The serial number shall be prefaced by words, an abbreviation, or a symbol, that clearly identifies the number as the required serial number.*
[Nonretroactive as of January 1, 1986]
 - (2) *Abbreviations for the word “Serial” shall, as a minimum, begin with the letter “S,” and abbreviations for the word “Number” shall, as a minimum, begin with the letter “N” (e.g., S/N, SN, Ser. No., and S. No.).*
[Nonretroactive as of January 1, 2001]
- (d) *the current software version or revision identifier ~~for not built for purpose software-based electronic devices,~~ which shall be directly linked to the software itself;*
[Nonretroactive as of January 1, 2004]
(Added 2003) (**Amended 20XX**)
 - (1) *The version or revision identifier shall be prefaced by words, an abbreviation, or a symbol, that clearly identifies the number as the required version or revision.*
[Nonretroactive as of January 1, 2007]
(Added 2006)
 - (2) *Abbreviations for the word “Version” shall, as a minimum, begin with the letter “V” and may be followed by the word “Number.” Abbreviations for the word “Revision” shall, as a minimum, begin with the letter “R” and may be followed by the word “Number.” The abbreviation for the word “Number” shall, as a minimum, begin with the letter “N” (e.g., No or No.).*
[Nonretroactive as of January 1, 2007]
(Added 2006)

(3) The version or revision identifier shall be accessible via the display. Instructions for displaying the version or revision identifier shall be described in the CC. As an exception, permanently marking the version or revision identifier shall be acceptable under the following conditions:

- i. The user interface does not have any control capability to activate the indication of the version or revision identifier on the display, or the display does not technically allow the version or revision identifier to be shown (analog indicating device or electromechanical counter) or**
- ii. the device does not have an interface to communicate the version or revision identifier.**

(e) an NTEP CC number or a corresponding CC Addendum Number for devices that have a CC.

(1) *The CC Number or a corresponding CC Addendum Number shall be prefaced by the terms “NTEP CC,” “CC,” or “Approval.” These terms may be followed by the word “Number” or an abbreviation of that word. The abbreviation for the word “Number” shall, as a minimum, begin with the letter “N” (e.g., No or No.) [Nonretroactive as of January 1, 2003]*

The required information shall be so located that it is readily observable without the necessity of the disassembly of a part requiring the use of any means separate from the device. (Amended 1985, 1991, 1999, 2000, 2001, 2003, ~~and~~, 2006 ~~and~~ **20XX**)

G-S.1.1. Location of Marking Information for ~~Not-Built-For-Purpose~~ All Software-Based Devices. – For ~~not-built-for-purpose~~, software-based devices, either:

- (a) The required information in G-S.1. Identification. (a), (b), ~~(d)~~, and (e) shall be permanently marked or continuously displayed on the device; or*
- (b) The CC Number shall be:*
 - (1) permanently marked on the device;*
 - (2) continuously displayed; or*
 - (3) accessible through an easily recognized menu and, if necessary, a submenu. Examples of menu and submenu identification include, but are not limited to, “Help,” “System Identification,” “G-S.1. Identification,” or “Weights and Measures Identification.”*

Note: *For (b), clear instructions for accessing the information required in G-S.1. (a), (b), and (d) shall be listed on the CC, including information necessary to identify that the software in the device is the same type that was evaluated. [Nonretroactive as of January 1, 2004] (Added 2003) (Amended 2006 ~~and~~ **20XX**)*

The Sector reported that the new language in G-S.1.1 reflects that the Sector reached consensus on the following positions:

- The software version/revision should (with very few exceptions – see D-31, 5.1.1.) be accessible via the user interface.
- The means by which the software version is accessed must be described in the Certificate of Conformance (CC).

The Sector noted that since the 2012 meeting, the Sector has attempted to promote this item via several means to try and address the concerns of other interested parties. A presentation was generated and shared with the S.M.A. at their 2012 meeting. Most of the regions had access to this information prior to their meetings, as it was posted on the NCWM website. Unfortunately, based on the comments in the 2013 NCWM Publication 15, Item 360-2, some regions were not aware that this information had been made available. The Sector also noted that they may want to consider more direct methods, in other words, designating a representative to address the regional groups or other sectors at their meetings. The Annual Meeting may be an appropriate venue for a presentation. To move this

forward, someone should address the regional groups. There are five to six potential venues for presentations. The last slide from the current presentation should be eliminated, to avoid confusing matters, for the time being. The two regional meetings in the fall (Western and Southern) and the Interim Meeting are probably more critical than the ones in May. Dr. Thompson was asked to relay that we have a presentation available and would like to push our proposal as a Voting Item in 2014.

After removing the “and inseparably” terminology from the proposal, the concerns on the possibility of controversy were reduced.

The Sector’s opinion on the interpretation of “directly linked” is that it means that you can’t change the version/revision without changing the software.

In addition, it was noted that it may be desirable to evaluate options that would lead to fully eliminating G-S.1.1. It was noted that this would be a more invasive modification to the existing Handbook and perhaps should be put off until the first step of addressing software in all devices (not just standalone) was accomplished.

The one response to our request for review/comment that contained negative feedback was undeniably vague and non-constructive. The issue seems to be more one of communication/understanding than disagreement with the intent or wording.

It was recommended that a couple examples be added to the current slide presentation, to illustrate the intent of the proposed changes. One example might be supermarket-specific software designed to run upon a cash register. Another example might be, after a software change, noting that the new software version/revision number is no longer the same, and the operator was not prompted to enter a version/revision number.

2013 NCWM Annual Meeting Open Hearings: The Committee heard a comment from Mr. Tim Tyson (Kansas), who recognized the Sector’s work on this item and suggested that consideration be given to changing the status of the item to Informational status. In considering this suggestion during its work session, the Committee agreed that the change might be appropriate; however, decided instead to seek input from the NTEP Sectors and industry associations before making that decision. Consequently, the Committee requested that the Sectors and industry associations review the Software Sector’s latest proposal at their next meetings.

360-3 D Part 3.30. Price Posting and Computing Capability and Requirements for a Retail Motor-Fuel Dispenser (RMFD)

Source:

NIST, OWM and the Regional Weights and Measures Associations (2008)

Purpose:

Review and update criteria in the LMD Code related to price posting and computing capability of RMFDs to reflect current market practices.

Item under Consideration:

The NCWM Task Group on RMFD Price Posting and Computing Capability developed specific proposals for modifying the LMD Code to address price posting and computing requirements for RMFDs. These proposals were adopted by the NCWM in 2012 and published in the 2013 NIST Handbook 44; they are being revisited at the request of the NCWM S&T Committee who has asked the Task Group to complete its review of sample receipts and provide guidance on applying the new criteria. Item 360-3 is being retained as a Developing Item pending any additional assignments that may be given by the Committee to the Task Group relative to the implementation of new code requirements that may be adopted. Comments or inquiries may be directed to NIST Technical Advisor, Ms. Juana Williams, at (301) 975-3989 or juana.williams@nist.gov.

Background/Discussion:

In the early 1990s, various sections of the LMD Code in NIST Handbook 44 were modified to address multi-tier pricing applications in instances where the same product is offered at different unit prices based on the method of payment (such as cash or credit) or other conditions of the sale. Since that time, marketing practices have evolved to include the addition of new practices, such as frequent shopper discounts and club member discounts. Numerous questions have been posed to NIST OWM and weights and measures officials regarding the requirements for posting unit prices, calculation of total price, customer-operated controls, and other related topics, such as definitions for associated terminology. It is clear from these questions that changes are needed to NIST Handbook 44 to ensure the requirements adequately address current marketplace conditions and practices. The Committee agreed that changes are needed to the LMD Code relative to these issues, and in 2010 the Committee established a task group to further develop this issue and present an alternative recommendation for its consideration.

Additional details on this item can be found in the Committee's 2008 - 2012 Final Reports.

2012 WWMA Annual Meeting: Ms. Williams reported that the NCWM Task Group (TG) on RMFD Price Posting and Computing Capability recently reviewed and approved NIST editorial changes to NIST Handbook 44, Section 3.30. Liquid-Measuring Devices, paragraph S.1.6.5.4. Selection of Unit Price. The TG Chair, Ms. Fran Elson-Houston (Ohio), continues to communicate with the NCWM S&T Committee Chairman and the NCWM Chairman to determine if the TG has any remaining assignments. Mr. Kurt Floren (Los Angeles County, California) encouraged feedback and input after everyone reviews the six paragraphs that will go into NIST Handbook 44 January 2013. He also suggested reviewing how these changes affect real life applications. The WWMA suggested the TG remain in place for at least a year after implementation of these six new requirements because it has the best knowledge of this issue to deal with any implementation issues that surface. WWMA recommended that the item remain as a Developing Item.

2012 NEWMA Interim Meeting: The association supported the efforts of the working group and recommended that the item remain as a Developing Item.

2012 SWMA Annual Meeting: The NCWM S&T Chairman reported that the NCWM S&T Committee has asked the RMFD Price Posting and Computing Capability TG to continue developing guidelines and examples, including sample receipt layouts, to illustrate how the changes to the LMD Code adopted in July 2012 are intended to be implemented. The SWMA looks forward to the TG's development of these guidelines. SWMA unanimously recommended that the item remain as a Developing Item while the TG continues its work.

2013 NCWM Interim Meeting Open Hearings: The Committee heard a suggestion from Ms. Elson-Houston, speaking as Chair of the TG on RMFD Price Posting and Computing Capability on a TG proposal, to further modify paragraph UR.3.3. Computing Device. Ms. Elson-Houston reported that the TG had met and agreed: 1) to develop sample receipts for transactions where motor fuel pricing is discounted after the delivery; 2) the Chair would provide input on the "Do's and Don'ts" for complying with the requirements that went into effect January 2013 for posting on *The Oil Express* web newsletter; and 3) to recommend additional amendments to paragraph UR.3.3., which were provided to the Committee. During its deliberations, the Committee reviewed the proposed changes recommended by the TG and agreed to establish a new Informational Item to address those modifications. The Committee also agreed to retain Developing Item 360-3 while the TG continues work to develop guidelines and examples on how the changes made last year to the LMD Code will apply to receipts for post-delivery discounted transactions. The above new information item established by the Committee is available in S&T Agenda Information Item 330-4 and is included in the section of this report that addresses Liquid-Measuring Devices Code requirements.

2013 NEWMA and CWMA Annual Meetings: Both associations supported this as a Developing Item. During the NEWMA meeting, Ms. Tina Butcher reported that Ms. Elson-Houston, Chairman of the Task Group, had been in contact with the NCWM S&T Committee Chair, Mr. Ken Ramsburg. Ms. Elson-Houston advised NIST that Mr. Ramsburg (Maryland, NCWM S&T Committee Chairman) is planning to suggest that the S&T Committee ask the NTEP Measuring Sector to develop further guidelines for use in type evaluation and, should additional assistance be needed after that point, to re-establish the Task Group at that time. NEWMA defers to the national S&T Committee to determine the continued need for this item.

On the 2013 NCWM Online Position Forum, one government representative indicated support for this item with no additional comments.

2013 NCWM Annual Meeting: The Committee heard comments from Ms. Williams who emphasized the importance of continuing to develop guidelines and information to assist regulatory officials and industry in interpreting and applying requirements relative to pre- and post-delivery discounts. NIST OWM is working on the development of guidelines and examples that could be included in NIST EPOs and training materials and has already received positive feedback from members of the Task Group on the examples developed thus far. This information may also be of use to NTEP in the further development of checklist criteria for inclusion in NCWM Publication 14. OWM will continue to develop this information and make it available in updates to EPOs and course materials and would appreciate additional input from the community.

Ms. Beth Treseder (API) indicated that API and others within industry would appreciate copies of acceptable receipts as they become available.

The Committee believes that additional work is needed to develop examples and information that will enable consistent and uniform application of the requirements adopted in 2012 and encourages OWM's continued work on such examples. The Committee asks that the Task Group continue its work by developing and providing additional examples of acceptable receipts to assist regulatory officials and industry in interpreting and applying these requirements. The Committee believes that examples of receipts from deliveries that include both pre- and post-delivery discounts in a single transaction are needed.

360-4 I Part 2.20. Weigh-In-Motion Vehicle Scales for Law Enforcement – Work Group

Note: This item was originally numbered Item 360-4 in the Committee's 2013 Interim Report. This item was moved to the 320 Scales Section and renumbered Item 320-5 during the Committee's Open Hearings.

360-5 D USNWG on Taximeters – Taximeter Code Revisions and Global Positioning System-Based Systems for Time and Distance Measurement

Note: This item was originally titled "Item 360-5 S.5. Provision for Security Seals" in the Committee's 2013 Interim Agenda. At the 2013 NCWM Interim Meeting, the Committee combined that item with "Item 354-1 Global Positioning Systems for Taximeters" and "Item 360-6 Global Positioning Systems for Taximeters" to create this new, consolidated item to address the development of recommendations on multiple topics related to taximeters and GPS-based time and distance measuring systems.

Source:

NIST USNWG on Taximeters

Purpose:

Develop recommendations for modifying the existing Taximeters Code to reflect current technology (including requirements for sealing, display requirements, and other features) and to examine GPS-based time and distance measuring systems to determine how to best address these measuring systems in NIST Handbook 44 to ensure accuracy and transparency for passengers and businesses.

Item Under Consideration:

This item is under development. Comments and inquiries may be directed to Mr. John Barton (NIST OWM) at (301) 975-4002 or john.barton@nist.gov.

The USNWG is considering proposals to modify the sealing requirements in the Taximeters Code to reflect more advanced sealing methods (see 2012 NCWM Final S&T Report); to amend the Taximeters Code to specifically recognize GPS-based time and distance measuring systems; and to amend other sections of the Taximeters Code to reflect current technology and business practices while ensuring accuracy and transparency for customers and a level playing field for transportation service companies.

Background/Discussion:

In January 2012, the Committee considered a proposal from Frias Transportation Infrastructure, LLC to modify Taximeters Code paragraph S.5. Provision for Security Seals to recognize more advanced methods of sealing. See Item 360-5 in the Committee's 2012 Final Report for details. This item appeared as "Item 360-5 S.5. Provision for Security Seals" in the Committee's 2013 Interim Agenda.

In January 2013, the Committee also considered a proposal from the City of Seattle's Consumer Affairs to amend NIST Handbook 44, Section 5.54. Taximeters to make it specifically apply to Global Positioning System (GPS) system applications used commercially to compute fares based upon distance and/or time measurements. See Item 360-6 in the Committee's 2012 Final Report for details; this item appeared as "Item 360-6 Global Positioning Systems for Taximeters" in the Committee's 2013 Interim Agenda.

In April 2012, in response to requests from the NCWM and members of the weights and measures community, NIST, OWM formally established a USNWG on Taximeters. The purpose of the USNWG was to continue work already in progress at NIST to develop proposed changes to the Taximeters Code to reflect current technology and to provide a forum in which stakeholders could work together to address issues such as those outlined in Items 360-5 and 360-6 on the Committee's 2012 Agenda. The USNWG includes participants from the taxi/vehicle-for-hire industry (owners & operators), manufacturers and developers of taximeters and taximeter systems, regulatory officials, and technical experts.

2012 WWMA Annual Meeting: Ms. Williams submitted a status report for NIST USNWG on Taximeters. Ms. Kristin Macey (California) expressed strong interest in the issue of GPS system applications being used to compute fares based upon distance and/or time. Currently, California DMS is the only NTEP type approval lab and while they look forward to having a device submitted, they wouldn't know what to do with the request. She opposed the carryover item (Item 360-6 Global Positioning Systems for Taximeters on the NCWM S&T Committee's Agenda) and asked that it be withdrawn, stating that it might be better considered under a new, separate code section. Mr. John Gaccione (Westchester County, New York) expressed other consumer concerns, such as access to receipts, the need of expensive smart phones, and that currently there is no regulatory oversight, whereas there are over 13,000 taxis now operating in that jurisdiction. Mr. Miguel Monroy (San Francisco, California), echoed Ms. Macey's concern that there was no regulatory oversight and that GPS systems have been active in his jurisdiction for two years. The WWMA concluded that it didn't have enough information on metrological accuracy of GPS in measurement of distance and time, and there may be other metrological parameters that will be part of the charges.

2012 SWMA Annual Meeting: Ms. Tina Butcher (NIST, OWM) submitted a status report for the NIST USNWG on Taximeters.

All of the regional weights and measures associations support the efforts of the USNWG. The WWMA and the SWMA further recommended that the NCWM S&T Committee consider consolidating the related items on Taximeters and GPS-based systems into a single item and designating the contact point as the USNWG.

2013 NCWM Interim Meeting: The Committee considered another proposal from the City of Seattle's Consumer Affairs to amend NIST Handbook 44, Section 5.54. Taximeters to make it specifically apply to Global Positioning System (GPS) system applications used commercially to compute fares based upon distance and/or time measurements. This proposal was designated as Item 354-1 in the Committee's Interim Agenda. No proposed language modifying the current Taximeters Code was submitted. At its fall 2012 Annual Meeting, the WWMA considered this item; this item was not submitted to the other regional associations. The WWMA noted that this item is similar to Item 360-6 in the NCWM S&T Committee's 2012 Final Report; like that item, it seeks to develop the Taximeter Code to apply specifically to GPS applications inputs and software programming in smart phone applications used commercially to compute fares based upon distance and/or time measurements. The WWMA forwarded the item to NCWM S&T Committee and recommended that it be combined with the item designated in the NCWM S&T Committee's Final Report as Developing "Item 360-6, Global Positioning Systems for Taximeters" and be addressed by the NIST USNWG on Taximeters; however, this item was designated as Item 354-1 on the NCWM S&T Committee's 2013 Interim Agenda.

2013 NCWM Interim Meeting Open Hearings: The Committee heard comments under Item 354-1 in support of work to further develop requirements to address GPS-based systems and to continue work on proposed revisions to the Taximeter Code to reflect current technology. NIST OWM provided the following update on the progress of the USNWG:

The USNWG on Taximeters held its first face-to-face meeting at NIST's Gaithersburg facility September 24 - 26, 2012. To provide the USNWG with necessary input and analysis regarding the capability of the GPS system, expertise in that area was solicited. A staff member from the NIST Time and Frequency Division has agreed to assist the USNWG in matters related to GPS and act as an observing member of the USNWG. While the September 2012 meeting was very productive, a great deal of work remains to be completed. Additional meetings are anticipated; the next meeting is scheduled via web conference for March 13, 2013, from 1:30 p.m. to 4:00 p.m. EST. The direction of the USNWG's continuing work will take place in the form of two concurrent projects.

The main body of the work group will target the completion of updating the existing Taximeters Code so that specifications and requirements apply to devices and technologies currently in use in this industry. The work of the USNWG will result in proposals to amend the Taximeters Code and NCWM Publication 14 where needed. Those proposals will then be submitted for consideration by the NCWM.

In addition to the work in updating the existing Taximeters Code, a Subcommittee is being formed and will specifically work towards the development of standards and requirements that will address the use of GPS as a source of commercial time and distance measurements. The work will involve amendment as needed of existing specification and performance requirements and the possible development of new requirements that will encompass the use of GPS.

This Subcommittee will also develop the necessary standards and test procedures for the evaluation of transportation-for-hire services that have recently been introduced using mobile telephone applications (apps) in the process of requesting, dispatching, and the calculation of fares for these services.

Mr. James Cassidy (City of Cambridge, Massachusetts), a member of the USNWG, rose in support of these efforts, and to encourage others with interest and expertise to participate in the work. The Committee also heard comments from Mr. Ross Andersen (New York, retired) who reflected on differences between standard length-measuring devices such as steel tapes and GPS-based systems. He also noted the need to address electronic receipts in any proposed revisions to the language.

The Committee heard no comments on Items 360-5, S.5. Provision for Security Seals; or 360-6 Global Positioning Systems for Taximeters during its Open Hearings. After considering the summary of the work being done by the USNWG; the comments heard during its Open Hearings; and comments from the regional associations regarding the overlap among these related items, the Committee decided to consolidate Item 354-1 Global Positioning Systems for Taximeters; Item 360-5 S.5. Provision for Security Seals; and Item 360-6 Global Positioning Systems for Taximeters into a single Developing Item, and to designate the USNWG on Taximeters as responsible for the item's development.

2013 NEWMA and CWMA Annual Meetings: Both associations supported this as a Developing Item. NEWMA heard updates from NIST and USNWG Members on the USNWG. NEWMA also heard comments from a member about whether or not GPS-based systems could ever provide comparable measurements to conventional taxi meters given how GPS systems work as they do not recognize changes in elevation. NEWMA noted the immediate need by some jurisdictions for this item and supports the work of the USNWG to move this item forward.

On the 2013 NCWM Online Position Forum, two government representatives supported continued development of the proposal by the USNWG. One government representative indicated a neutral position, noting that these devices are not regulated by the weights and measures authority in his state. **Technical Advisor's note:** *The results and comments from the Forum reflect the combined positions and comments for S&T agenda Items 354-1 and 360-5, which were combined at the 2013 NCWM Interim Meeting to create this new consolidated agenda item.*

2013 Annual Meeting Open Hearings: The Committee heard an update on the work of the USNWG from Ms. Williams. She noted that the USNWG held a teleconference on July 10 and has established a Subcommittee to address GPS-based time and distance measuring systems. The USNWG meets about every other month via either web or in-person meetings. Mr. John Barton (NIST OWM) Chair and Technical Advisor to the USNWG further noted that the USNWG includes an expert in GPS measurements from NIST's Time and Frequency Division, Mr. Mike Lombardi.

The Committee heard comments from Mr. Andersen, who questioned whether or not GPS-based systems account for variations in elevation. Other members commented that many GPS based devices do have the capability to account for these changes.

The Committee encourages the continued work of the USNWG and looks forward to continued developments in this area.

360-6 D Global Positioning Systems for Taximeters

Note: At the 2013 NCWM Interim Meeting, the Committee combined this item with "Item 354-1 Global Positioning Systems for Taximeters" and "Item 360-5, S.5. Provision for Security Seals" to create a new, consolidated Developing Item. The consolidated Developing Item is designated as "Item 360-5 USNWG on Taximeters – Taximeter Code Revisions and Global Positioning Systems for Time and Distance Measurement." See Item 360-5 for details.

360-7 D Appendix D – Definitions: Remote Configuration Capability

Source:

NTEP Grain Analyzer Sector (2013)

Purpose:

Expand the scope of definition to cover instances where the "other device," as noted in the current definition, may be necessary to the operation of the weighing or measuring device or which may be considered a permanent part of that device.

Item Under Consideration:

This item is under development. Comments and inquiries may be directed to NIST Office of Weights and Measures.

A proposal to modify the definition for "remote configuration capability" as follows is under consideration:

remote configuration capability. – The ability to adjust a weighing or measuring device or change its sealable parameters from or through some other device that ~~is not~~ may or may not itself be necessary to the operation of the weighing or measuring device or ~~is not~~ may or may not be a permanent part of that device.[2.20, 2.21, 2.24, 3.30, 3.37, 5.56(a)]

(Added 1993) (Amended 20XX)

Background/Discussion:

Removable digital storage devices can be used in GMMs either as data transfer devices that are not necessary to the operation of the GMM or as data storage devices that are necessary to the operation of the GMM. If removal data storage devices are necessary to the operation of the device, they are not covered by the current definition of remote configuration capability.

A USB flash drive is most likely to be used as a data transfer device. In a typical data transfer application, the USB flash drive is first connected to a computer with access to the GMM manufacturer's web site to download the latest grain calibrations that are then stored in the USB flash drive. The USB flash drive is removed from the computer

and plugged into a USB port on the GMM. The GMM is put into remote configuration mode to copy the new grain calibration data into the GMM's internal memory. When the GMM has been returned to normal operating (measuring) mode, the USB flash drive can be removed from the GMM.

Although a Secure Digital (SD) memory card could also be used as a data transfer device it is more likely to be used as a data storage device. In a typical "data storage device" application, the SD memory card stores the grain calibrations used on the GMM. The SD memory card must be plugged into an SD memory card connector on a GMM circuit card for the GMM to operate in measuring mode. To install new grain calibrations the GMM must be turned "off" or put into a mode in which the SD memory card can be safely removed. The SD memory card can either be replaced with an SD memory card that has been programmed with the new grain calibrations or the original SD memory card can be re-programmed with the new grain calibrations in much the same way as that described in the preceding paragraph to copy new grain calibrations into a USB flash drive. In either case, the SD memory card containing the new calibrations must be installed in the GMM for the GMM to operate in measuring mode. In that regard, the SD memory card (although removable) can be considered a permanent part of the GMM in that the GMM cannot operate without it.

Note: In the above example, the SD memory card could be any removable flash memory card such as the Secure Digital Standard-Capacity, the Secure Digital High-Capacity, the Secure Digital Extended-Capacity, and the Secure Digital Input/Output, which combines input/output functions with data storage. These come in three form factors: the original size, the mini size, and the micro size. A Memory Stick is a removable flash memory card format, launched by Sony in 1998, and is also used in general to describe the whole family of Memory Sticks. In addition to the original Memory Stick, this family includes the Memory Stick PRO, the Memory Stick Duo, the Memory Stick PRO Duo, the Memory Stick Micro, and the Memory Stick PRO-HG.

At its 2011 Grain Analyzer Sector Meeting the Sector agreed by consensus that the following changes to Table S.2.5. of Section 5.56.(a) of NIST Handbook 44 should be forwarded to the S&T Committee for consideration:

- Add a note to Table S.2.5. to recognize the expanded scope of remote capability.
- Delete "remotely" from the second paragraph of Category 3 requirements that begins, "When accessed remotely..." to make it clear that the requirements of Category 3 apply whether accessed manually using the keyboard or accessed by remote means.
- Add the modified second paragraph of Category 3 requirements to Categories 3a and 3b to make it clear that these requirements apply to all the subcategories of Category 3.

After additional review of this item, NIST, OWM recommended that the changes to Table S.2.5. approved by the Sector in 2011 be separated into two independent proposals: one dealing with the changes to Category 3 and its subcategories; and one recommending a modification of the definition of "remote configuration capability" appearing in Appendix D of NIST Handbook 44 to recognize the expanded scope of remote capability, instead of adding a note to the bottom of Table S.2.5. to expand the definition for remote configuration for grain moisture meters (as shown in this proposal). A change to the definition of remote configuration capability will apply to other device types.

At its 2012 Meeting, the Grain Analyzer Sector agreed to separate its original proposal into two separate proposals and agreed to forward this proposal to change the definition of "remote configuration capability" to the S&T Committee for consideration. (See also August 2012 NTEP Grain Analyzer Sector Summary, Item 5.)

2012 WWMA Annual Meeting: Ms. Juana Williams (NIST, OWM) supported the intent. She talked about this item in conjunction with Item 356-1, S.2.5. Categories of Device and Methods of Sealing. This is a complex item affecting multiple other devices; therefore, the proposal requires further consideration. The language in the proposal to amend the definition of remote configuration capability is confusing. The Committee believes the current definition already allows the use of remote configuration devices and allows the flexibility desired. The

ramifications of changing the definition could affect other devices in NIST Handbook 44. WWMA did not forward this item to NCWM.

2012 SWMA Annual Meeting: There were no comments. After reviewing the proposal and considering the potential impact on other device types, the Committee recommended this as a Developing Item. The Committee asks that the Sector continue to obtain input on the definition and the impact the changes would have on other device types. SWMA forwarded the item to NCWM, recommending it as a Developing Item and assigning its development to the Grain Analyzer Sector.

2013 NCWM Interim Meeting Open Hearings: The Committee heard comments from Ms. Williams. NIST, OWM suggested the Committee consider this item as a Developing Item to allow other sectors to discuss how a change to the definition may affect other device types of similar design and to consider changes, if needed. NIST, OWM recognizes that the current definition for “remote configuration capability” may not address those grain moisture meters (GMMs) that can only be operated with a removable data storage device, containing, among other things, the grain calibrations intended for use with the GMM, inserted in the device (as was described by the Grain Analyzer Sector). As such, OWM noted that current sealing requirements were developed at a time when such technology likely didn’t exist, nor could be envisioned, and are based on the current definition of remote configuration capability. Because the current definition was never intended to apply to this “next generation” technology, NIST, OWM suggested that those charged with further development of this item may wish to revisit the five philosophies of sealing and consider whether a new paragraph, completely separate from current sealing requirements, might be appropriate and a better option, than the one currently proposed. The five philosophies of sealing are included in the 1992 Report of the 77th National Conference on Weights and Measures (Report of the Specifications and Tolerances Committee). Another option, preferred over the changes currently proposed, would be to add a separate statement to the current definition of “remote configuration capability” to address removable storage devices. For example, the following sentence might be considered as an addition to the current definition for “remote configuration capability:”

Devices which are programmed using removable media (such as SD cards, flash drives, etc.) that may or may not be required to remain with the device during normal operation are also considered to be remotely configured devices.

The Committee also heard comments from Mr. Dmitri Karimov (Liquid Controls Corporation, LLC), speaking on behalf of the MMA, who made two points: 1) Flow computers may already have these capabilities, thus it may be more appropriate to consider adding requirements to the General Code so that the requirements will be uniformly applied to all device types; and 2) the Committee should look ahead and consider other capabilities that may or already have emerged such as wireless communication and configuration.

The Committee acknowledged the comments indicating that the current definition of “remote configuration capability” was developed at a time when certain technologies, such as blue tooth, SD storage devices, flash drives, and other media didn’t exist. The Committee recognized that it may be difficult to modify the existing definition and associated requirements to be flexible enough to address emerging and future technologies without having a significant (and possibly detrimental impact) on existing devices. Consequently, rather than modifying the current definition, the Committee concluded that a better approach might be to develop an entirely separate set of security requirements that would apply to emerging technologies. The Committee believes that additional work is needed to develop proposed definition(s) and associated requirements and decided to designate the item as Developmental. The Committee requests other sectors review the Grain Sector’s proposed modification to the definition as well as NIST, OWM’s suggestions and provide input.

2013 NEWMA and CWMA Annual Meetings: Both associations supported this as a Developing Item. NEWMA heard from NIST who encouraged members to consider this work as it applies to all device types.

On the 2013 NCWM Online Position Forum, one government representative indicated a neutral position on this item with no additional comments.

2013 NCWM Annual Meeting Open Hearings: The Committee heard comments from Ms. Williams who reiterated NIST, OWM’s comments from the 2013 Interim Meeting, suggesting that it may be appropriate to develop separate

requirements to address new and future technologies that can be remotely configured with removable media. NIST, OWM plans to develop draft language and ask for input from the various Sectors at their upcoming meetings. Ms. Williams also noted the suggestion made at the 2013 NCWM Interim Meeting by Mr. Karimov speaking on behalf of the MMA, that a provision might be added to the General Code to address this type of equipment.

Ms. Julie Quinn (Minnesota) agreed with NIST, OWM's comments and indicated support for possibly including requirements in the General Code to address newer and emerging technologies. Mr. Karimov, speaking on behalf of MMA, concurred with this suggestion.

Mr. Kenneth Ramsburg, Maryland | Committee Chair
Mr. Paul Moyer, Nebraska | Member
Mr. Brett Gurney, Utah | Member
Mr. Mahesh Albuquerque, Colorado | Member
Ms. Jane Zulkiewicz, Town of Barnstable, MA | Member¹
Mr. Luciano Burtini, Measurement Canada | Canadian Technical Advisor
Ms. Tina Butcher, NIST, OWM | NIST Technical Advisor
Mr. Rick Harshman, NIST, OWM | NIST Technical Advisor

Specifications and Tolerances Committee

¹ In February 2013, Ms. Jane Zulkiewicz replaced Mr. Ed Seidler, Town of Framingham, Massachusetts, (who served on the Committee from July 2012 to February 2013) as the Northeastern regional representative.

Appendix A

Items 337-1 and 337-2: Background and Justification for Handbook 44 Definition of “Diesel Gallon Equivalent (DGE)” of Natural Gas as a Vehicular Fuel

Clean Vehicle Education Foundation

Development of the “Gasoline Gallon Equivalent” by NCWM*

In 1993, under the auspices of the National Conference on Weights and Measures (NCWM), a Compressed Natural Gas (CNG) Working Group came together to determine the way in which CNG would be sold to the public at retail as a motor fuel.

The working group focused on three issues:

1. How to provide the Natural Gas Vehicle (NGV) industry a method of sale that would be familiar and acceptable to consumers
2. How to provide weights and measures officials a verifiable and quantifiable means to determine the accuracy of natural gas dispensers; and
3. How to meet these requirements with a uniform, national standard.

NCWM considered three proposals for the method of sale of CNG:

1. joules, the unit of energy measurement in SI units
2. mass
3. the Gasoline Gallon Equivalent (GGE)

The Natural Gas Vehicle Coalition (now NGV America) recommended that the Gasoline Gallon Equivalent be adopted as the method of sale for CNG, and that it be based on the energy equivalent of a gallon of gasoline. The use of the GGE was recommended primarily for the convenience of the retail customer comparing the cost and fuel economy of a natural gas vehicle to a comparable gasoline vehicle. During the discussion, a proposal was made to eliminate the reference to energy content of CNG and replace it with a fixed conversion factor based on mass, with the fixed mass of CNG being equal to a gallon of gasoline. Measurement of mass in the retail dispenser and

* *Report of the 78th National Conference on Weights and Measures, 1993*, NIST Special Publication 854, pp 322-326.

Report of the 79th National Conference on Weights and Measures, 1994, NIST Special Publication 870, pp 213-217.

Program and Committee Reports for the National Conference on Weights and Measures, 79th Annual Meeting, July 17 - 21, 1994, NCWM Publication 16, pp 89-92.

verification by W&M officials is easier and less costly than measurement of energy content.

Since the energy content of a unit measure of CNG (standard cubic foot - scf) and gasoline (gallon) vary widely depending on the sample of fuel measured, the reference gallon of gasoline was determined to be Indolene, the gasoline used by EPA to certify emissions and fuel economy, with an energy content (lower heating value) of 114,118 BTU/gal. Work conducted by the Institute of Gas Technology and the Gas Research Institute (now combined into the Gas Technology Institute) surveyed 6811 samples of natural gas nationwide and concluded that the “average” natural gas in the US had an energy content (lower heating value) of 923.7 BTU/scf, and a density of 0.0458172 lbs/cubic foot. This translates 20,160.551 BTU/lb. Dividing gasoline’s 114.118 BTU/gal by natural gas’s 20,160.551 BTU/lb gives 5.660 lbs of natural gas = 1 GGE. Similar calculations determined that a gasoline liter equivalent of natural gas equals 0.678 kg of natural gas.

At its 79th annual meeting in July of 1994, NCWM adopted resolutions that:

“All natural gas kept, offered or exposed for sale or sold at retail as a vehicle fuel shall be in terms of the gasoline liter equivalent (GLE) or gasoline gallon equivalent (GGE), and

All retail natural gas dispensers shall be labeled with the conversion factor in terms of kilograms or pounds. The label shall be permanently and conspicuously displayed on the face of the dispenser and shall have either the statement “1 Gasoline Liter Equivalent (GLE) is equal to 0.678 kg of Natural Gas” or “1 Gasoline Gallon Equivalent (GGE) is equal to 5.660 lbs of Natural Gas” according to the method of sale used.”

These statements can be found in NIST Handbook 130^{*}, along with the definition of “natural gas” which seems to apply only to Compressed Natural Gas, not to Liquefied Natural Gas. Handbook 130, §§3.11 and 3.12 (Engine Fuels, Petroleum Products, and Automotive Lubricants Regulations) confirm that these requirements are for CNG, rather than LNG. Similar requirements and definitions are found in Handbook 44.

During the discussions it was recognized that, although diesel and gasoline are both sold in gallon units, a gallon of diesel fuel has substantially more energy content than a gallon of gasoline. While it is convenient to use the Gasoline Gallon Equivalent unit when comparing the cost and fuel economy of gasoline-powered light-duty vehicles to equivalent natural gas vehicles, a Diesel Gallon Equivalent unit would be more useful for operators of medium and heavy-duty (usually diesel powered) vehicles. However, in 1994, the NCWM working group “agreed to defer development of a “Diesel Gallon

* “Method of Sale Regulation,” §2.27

Equivalent” until the issues related to the ‘Gasoline Gallon Equivalent’ were decided by the NCWM and agreed to meet again if additional work is necessary.”** The issue of the formal definition a Diesel Gallon Equivalent (DGE) unit has not come before NCWM from that time until today, although the DGE is often used in the industry, defined as 6.31 lbs of natural gas.

Need for a Definition of a “Diesel Gallon Equivalent” Unit

Today there are an increasing number of commercial vehicles using natural gas as a fuel, to lower emissions and Greenhouse Gases, decrease America’s use of petroleum, and lower fuel costs (U.S. DOE Clean Cities Alternative Fuel Price Report for April 2012 shows in Table 2 ‘Overall Average Fuel Price on Energy-Equivalent Basis’ that diesel is priced at \$4.12/gal and CNG at \$2.32/gal http://www.afdc.energy.gov/afdc/pdfs/afpr_apr_12.pdf).

Since the NCWM’s working group deferred development of a DGE unit in 1994, there has been little call by the natural gas vehicle industry for the formalization of that unit in the sale of **Compressed** Natural Gas. However the use of **Liquefied** Natural Gas (LNG) as a motor fuel has been growing and there is significant interest in using the DGE as a unit for the sale of that fuel.

LNG as a motor fuel is used almost exclusively by commercial vehicles, most of which view diesel as the conventional alternative. Using the same logic as was used for the development of the GGE unit, the convenience of the retail customer comparing the cost and fuel economy of a natural gas vehicle to a comparable conventional vehicle, it makes sense for NCWM to now “officially” define the DGE.

Other than §3.12. Liquefied Natural Gas, in the Engine Fuels and Automotive Lubricants Regulation section of Handbook 130, we find no specific provisions in either Handbook 44 or Handbook 130 for the retail sale of LNG as a motor fuel. However LNG is sold in California and other states on a mass basis (by the pound), which allows for easy confirmation by weights and measures authorities. An “official” definition of the DGE as a specific mass of natural gas would allow states to easily move from retail sale by pound to retail sale by DGE, simplifying the sale process for the retail customer used to dealing with “gallons of diesel” as a fuel measure.

Therefore, at this time we are asking for a definition of the Diesel Gallon Equivalent (and Diesel Liter Equivalent) units by NCWM.

Justification of the Definition of a DGE as 6.312 Pounds of Natural Gas

Handbook 130 contains the following definitions of natural Gas as a vehicle fuel*:

Gasoline liter equivalent (GLE). – Gasoline liter equivalent (GLE) means
0.678 kg of natural gas.

Gasoline gallon equivalent (GGE). – Gasoline gallon equivalent (GGE) means
2.567 kg (5.660 lb) of natural gas.

** *Report of the 79th National Conference on Weights and Measures, 1994*, NIST Special Publication 870, p 214

* NIST handbook 130, 2006, Method of State Regulation, §§2.27.1.2 and 2.227.1.3; also Engine Fuels, Petroleum Products, and Automotive Lubricants Regulation, §§1.25 and 1.26.

As the NCWM working group recognized during its deliberations in 1993 on the Gasoline Gallon Equivalent unit, both gasoline and natural gas can vary in their BTU content from sample to sample. The working group determined the gasoline gallon (energy) equivalent based on a gallon of Indolene (114,118 BTU/gal – lower heating value) and a survey of 6811 natural gas samples nationwide with an average of 923.7 BTU/scf (lower heating value) and a density of 0.0458172 lbs/cubic foot. This equates to 20,160.551 BTU/lb. Dividing gasoline's 114.118 BTU/gal by natural gas's 20,160.551 BTU/lb gives 5.660 lbs of natural gas = 1 GGE. Similar calculations determined that a gasoline liter equivalent of natural gas equals 0.678 kg of natural gas.

Starting with 5.660 lbs of natural gas = 1 GGE and 0.678 kg of natural gas = 1 GLE, we can calculate the mass of natural gas necessary to make a DGE and a DLE by comparing the amount of energy in a gallon of diesel fuel to the amount of energy in a gallon of gasoline fuel and apply that ratio to scale up the masses of natural gas calculated for the GGE and GLE units.

Unfortunately it is no easier today than it was in 1993 to set one energy value as representative of a unit for all gasoline, (or diesel) fuel. EPA's certification fuel has likely changed in energy content since 1993, as both gasoline and diesel fuels have been modified for improved emissions.

We recommend using the most recent Department of Energy *Transportation Energy Data Book*^{*}, as an authoritative reference for both gasoline and diesel fuel energy values. Taking further surveys or basing our calculations on today's EPA certification fuel only delays our action, substantially increases costs, and, in the end, provides a limited potential increase in accuracy based on one point in time. Table B.4 of the *Transportation Energy Data Book*, on the heat content of fuels http://cta.ornl.gov/data/tedb30/Edition30_Full_Doc.pdf lists the net energy of gasoline as 115,400 BTU/Gal, and diesel as 128,700 BTU/Gal.

Therefore a Diesel Gallon Equivalent of natural gas is:

$$(128,700/115,400) \times 5.660 = 6.312 \text{ lb (2.863 kg)}$$

and a Diesel Liter Equivalent of natural gas is:

$$(128,700/115,400 \times 0.678 = 0.756 \text{ kg}$$

Prepared by:
Clean Vehicle Education Foundation
<http://www.cleanvehicle.org>

^{*} Stacy C. Davis and Susan W. Diegel, Oak Ridge National Laboratory, *Transportation Energy Data Book*, Edition 30, 2011, ORNL-6978, or <http://cta.ornl.gov/data/index.shtml>

Appendix B

Item 360-4 Draft Tentative Code Applicable to Weigh-In-Motion Systems Used for Vehicle Enforcement Screening

Section 2.25. Weigh-In-Motion Systems used for Vehicle Enforcement Screening – Draft Code

A. Application

- A.1. General.** – This code applies to systems used to weigh vehicles, while in motion, for the purpose of screening and sorting the vehicles based on the vehicle weight to determine if a static weighment is necessary.
- A.2.** The code does not apply to weighing systems intended for the collection of statistical traffic data.
- A.3.** The code is intended for field enforcement use only.
- A.4. Additional Code Requirements.** – In addition to the requirements of this code, Weigh-In-Motion Screening Systems shall meet the requirements of Section 1.10. General Code.

S. Specifications

S.1. Design of Indicating and Recording Elements and of Recorded Representations.

S.1.1. Ready Indication. – The system shall provide a means of verifying that the system is operational and ready for use.

S.1.2. Value of System Division Units. – The value of a system division “d” expressed in a unit of weight shall be equal to:

- (a) 1, 2, or 5; or
- (b) a decimal multiple or submultiple of 1, 2, or 5.

Examples: divisions may be 10, 20, 50, 100; or 0.01, 0.02, 0.05; or 0.1, 0.2, 0.5, etc.

S.1.2.1. Units of Measure. – The system shall indicate weight values using only a single unit of measure.

S.1.3. Value of Other Units of Measure.

S.1.3.1. Speed. – Vehicle speeds shall be measured in miles per hour or kilometers per hour.

S.1.3.2. Axle-Spacing (Length). – The center-to-center distance between any two successive axles shall be measured in feet and/or inches, or meters.

S.1.3.3. Vehicle Length. – If the system is capable of measuring the overall length of the vehicle, the length of the vehicle shall be measured in feet and/or inches, or meters.

S.1.4. Capacity Indication. – An indicating or recording element shall not display nor record any values greater than 105 % of the specified capacity of the load receiving element.

S.1.5. Identification of a Fault. – Fault conditions shall be presented to the operator in a clear and unambiguous means. The following fault conditions shall be identified:

- (a) Vehicle speed is below the minimum or above the maximum speed as specified.
- (b) The maximum number of vehicle axles as specified has been exceeded.
- (c) A change in vehicle speed greater than that specified has been detected.

S.1.6. Recorded Representations.

S.1.6.1. Values to be Recorded. – At a minimum, the following values shall be printed and/or stored electronically for each vehicle weighment:

- (a) transaction identification number;
- (b) lane identification (required if more than one lane at the site has the ability to weigh a vehicle in-motion);
- (c) vehicle speed;
- (d) number of axles;
- (e) weight of each axle;
- (f) identification and weight of axles groups;
- (g) axle spacing;
- (h) total vehicle weight;
- (i) all fault conditions that occurred during the weighing of the vehicle;
- (j) violations, as identified in paragraph S.2.1., that occurred during the weighing of the vehicle; and
- (k) time & date.

S.1.7. Value of the Indicated and Recorded System Division. – The value of the system's division size as recorded shall be the same as the division value indicated.

S.2. System Design Requirements.

S.2.1. Violation Parameters. – The instrument shall be capable of accepting user entered violation parameters for the following items:

- (a) single axle weight limit;
- (b) axle group weight limit;
- (c) gross vehicle weight; and
- (d) bridge formula load.

The instrument shall display and or record violation conditions when these parameters have been exceeded.

S.3. Design of Weighing Elements.

S.3.1. Multiple Load-Receiving Elements. – An instrument with a single indicating or recording element, or a combination indicating-recording element, that is coupled to two or more load-receiving elements with independent weighing systems, shall be provided with means to prohibit the activation of any load-receiving element (or elements) not in use, and shall be provided with automatic means to indicate clearly and definitely which load-receiving element (or elements) is in use.

S.4. Design of Weighing Devices, Accuracy Class.

S.4.1. Designation of Accuracy. – WIM Systems meeting the requirements of this code shall be designated as accuracy Class A.

S.5. Marking Requirements. – In addition to the marking requirements in G-S.1. Identification (except G-S.1.(e)), G-S.4. Interchange or Reversal of Parts, G-S.6. Marking Operational Controls, Indications, and Features, G-S.7. Lettering, and G-UR.2.1.1. Visibility of Identification. The system shall be marked with the following information:

- (a) Accuracy Class;
- (b) Value of the System Division “d”;
- (c) Operational Temperature Limits;
- (d) Number of Lanes;
- (e) Minimum and Maximum Vehicle Speed;
- (f) Maximum Number of Axles per Vehicle;
- (g) Maximum Change in Vehicle Speed during Weighment; and
- (h) Minimum and Maximum Load.

S.5.1. Location of Marking Information. – The marking information required in G-S.1. Identification of the General Code and S.5. shall be visible after installation. The information shall be marked on the system or recalled from an information screen.

N. Notes

N.1. Test Procedures.

N.1.1. Selection of Test Vehicles. – All dynamic testing associated with the procedures described in each of the subparagraphs of N.1.5 shall be performed with a minimum of two test vehicles.

- (a) The first test vehicle may be a two axle, six tire, single unit truck; a vehicle with two axles with the rear axle having dual wheels. The vehicle shall have a maximum Gross Vehicle Weight of 10 000 lbs.
- (b) The second test vehicle shall be a five axle, single trailer truck with a maximum Gross Vehicle Weight of 80,000 lbs.

Note: Consideration should be made for testing the systems using vehicles which are typical to the systems daily operation.

N.1.1.1. Weighing of Test Vehicles. – All test vehicles shall be weighed on a reference scale before being used to conduct the dynamic tests.

N.1.2. Test Loads.

N.1.2.1. Static Test Loads. – All static test loads shall use certified test weights.

N.1.2.2. Dynamic Test Loads. – Test vehicles used for dynamic testing shall be loaded to 85 % to 95 % of their maximum Gross Vehicle Weight. The “load” shall be non-shifting and shall be positioned to present as close as possible, an equal side-to-side load.

N.1.3. Reference Scale. – Each reference vehicle shall be weighed on a static scale meeting NIST Handbook 44, Class III L maintenance tolerances.

N.1.3.1. Location of a Reference Scale. – The location of the Reference Scale must be considered as vehicle weights will change due to fuel consumption.

N.1.4. Test Speeds. – All dynamic tests shall be conducted within 20 % below or at the posted speed limit.

N.1.5. Test Procedures.

N.1.5.1. Dynamic Load Test. – The dynamic test shall be conducted using the test vehicles defined in N.1.1. The test shall consist of a minimum of 20 runs for each test vehicle at the speed as stated in N.1.4. Test Speeds. The tolerance for each run shall be based on the percentage values specified in Table T.3.1. Tolerances for Accuracy Class A.

N.1.5.2. Axle Spacing Test. – The axle spacing test is a review of the displayed and/or recorded axle spacing distance of the test vehicles. The tolerance value for each distance shall be based on the tolerance value specified in T.3.2. Axle Spacing Tolerance.

N.1.5.3. Position of Vehicle during Test Runs. – During the conduct of the dynamic testing the vehicle shall adjust its position along the width of the sensor from one run to the next but ensuring that the vehicle stays within the defined roadway. The test shall be conducted with 10 runs in the center, 5 runs on the right side, and five runs on the left side. All weightings shall be within tolerance.

T. Tolerances

T.1. Principles.

T.1.1. Design. – The tolerance for a weigh-in-motion system is a performance requirement independent of the design principle used.

T.2. Tolerance Application.

T.2.1. General. – The tolerance values are positive (+) and negative (-). No more than 5% of each test shall be outside the applicable tolerances

T.3. Tolerance Values for Accuracy Class A.

T.3.1. Tolerance Values for Dynamic Testing. – The tolerance values applicable during dynamic load testing are as specified in Table T.3.1. Tolerances for Accuracy Class A.

Table T.3.1. – Tolerances for Accuracy Class A	
Load Description	Tolerance as a Percentage of Applied Test Load
Axle Load	20 %
Axle Group Load	15 %
Gross Vehicle Weight	10 %

T.3.2. Axle Spacing Tolerance. – The tolerance value applied to the axle spacing measurement shall be ± 0.5 ft (0.15 m).

T.4. Influence Factors. – The following factors are applicable to tests conducted under controlled conditions only.

T.4.1. Temperature. – Systems shall satisfy the tolerance requirements under all operating temperature unless a limited operating temperature range is specified by the manufacturer.

T.5. Radio Frequency Interference (RFI) and Other Electromagnetic Interference Susceptibility. – The difference between the weight indication due to the disturbance and the weight indication without the disturbance shall not exceed the tolerance value as stated in Table T.3.1. Tolerances for Accuracy Class A.

UR. User Requirements

UR.1. Selection Requirements. – Equipment shall be suitable for the service in which it is used with respect to elements of its design, including but not limited to, its capacity, number of scale divisions, value of the scale division or verification scale division and minimum capacity.

UR.2. User Location Conditions and Maintenance. – The system shall be installed and maintained as defined in the manufacturer’s recommendation.

UR.2.1. System Modification. – The dimensions (e.g., length, width, thickness, etc.) of the load receiving element of a system shall not be changed beyond the manufacturer’s specifications, nor shall the capacity of a scale be increased beyond its design capacity by replacing or modifying the original primary indicating or recording element with one of a higher capacity, except when the modification has been approved by a competent engineering authority, preferably that of the engineering department of the manufacturer of the system, and by the weights and measures authority having jurisdiction over the system.

UR.2.2. Foundation, Supports, and Clearance. – The foundation and supports shall be such as to provide strength, rigidity, and permanence of all components.

On load-receiving elements which use moving parts for determining the load value, clearance shall be provided around all live parts to the extent that no contacts may result when the load-receiving element is empty, nor throughout the weighing range of the system.

UR.2.3. Access to Weighing Elements. – If necessary, adequate provision shall be made for inspection and maintenance of the weighing elements.

UR.3. Maximum Load. – A system shall not be used to weigh a load of more than the marked maximum load of the system.

The following are proposed definitions to be added to NIST Handbook 44, Appendix D to support the Weigh-In-Motion Systems used for Vehicle Enforcement Screening – Draft Code.

weigh-in-motion (WIM). – A process of estimating a moving vehicle’s gross weight and the portion of that weight that is carried by each wheel, axle, or axle group, or combination thereof, by measurement and analysis of dynamic vehicle tire forces.

axle. – The axis oriented transversely to the nominal direction of vehicle motion, and extending the full width of the vehicle, about which the wheel(s) at both ends rotate.

axle-group load. – The sum of all tire loads of the wheels on a group of adjacent axles; a portion of the gross-vehicle weight.

axle load. – The sum of all tire loads of the wheels on an axle; a portion of the gross-vehicle weight.

axle spacing. – The distance between the centers of any two axles. When specifying axle spacing, you also need to identify the axles used.

single-axle load. – The load transmitted to the road surface by the tires lying on the same longitudinal axis (that axis transverse to the movement of the vehicle and about which the wheels rotate).

tandem-axle load. – The load transmitted to the road surface by the tires of two single-axles lying on the same longitudinal axis (that axis transverse to the movement of the vehicle and about which the wheels rotate).

triple-axle load. – The load transmitted to the road surface by the tires of three single-axles lying on the same longitudinal axis (that axis transverse to the movement of the vehicle and about which the wheels rotate).

Weigh-in-Motion Screening Scale. – A WIM system used to identify potentially overweight vehicles.

wheel weight. – The weight value of any single or set of wheels on one side of a vehicle on a single axle.

WIM System. – A set of sensors and supporting instruments that measure the presence of a moving vehicle and the related dynamic tire forces at specified locations with respect to time; estimate tire loads; calculate speed, axle spacing, vehicle class according to axle arrangement, and other parameters concerning the vehicle; and process, display, store, and transmit this information. This standard applies only to highway vehicles.

Appendix A

Items 337-1 and 337-2: Background and Justification for Handbook 44 Definition of “Diesel Gallon Equivalent (DGE)” of Natural Gas as a Vehicular Fuel

Clean Vehicle Education Foundation

Development of the “Gasoline Gallon Equivalent” by NCWM*

In 1993, under the auspices of the National Conference on Weights and Measures (NCWM), a Compressed Natural Gas (CNG) Working Group came together to determine the way in which CNG would be sold to the public at retail as a motor fuel.

The working group focused on three issues:

1. How to provide the Natural Gas Vehicle (NGV) industry a method of sale that would be familiar and acceptable to consumers
2. How to provide weights and measures officials a verifiable and quantifiable means to determine the accuracy of natural gas dispensers; and
3. How to meet these requirements with a uniform, national standard.

NCWM considered three proposals for the method of sale of CNG:

1. joules, the unit of energy measurement in SI units
2. mass
3. the Gasoline Gallon Equivalent (GGE)

The Natural Gas Vehicle Coalition (now NGV America) recommended that the Gasoline Gallon Equivalent be adopted as the method of sale for CNG, and that it be based on the energy equivalent of a gallon of gasoline. The use of the GGE was recommended primarily for the convenience of the retail customer comparing the cost and fuel economy of a natural gas vehicle to a comparable gasoline vehicle. During the discussion, a proposal was made to eliminate the reference to energy content of CNG and replace it with a fixed conversion factor based on mass, with the fixed mass of CNG being equal to a gallon of gasoline. Measurement of mass in the retail dispenser and

* *Report of the 78th National Conference on Weights and Measures, 1993*, NIST Special Publication 854, pp 322-326.

Report of the 79th National Conference on Weights and Measures, 1994, NIST Special Publication 870, pp 213-217.

Program and Committee Reports for the National Conference on Weights and Measures, 79th Annual Meeting, July 17 - 21, 1994, NCWM Publication 16, pp 89-92.

verification by W&M officials is easier and less costly than measurement of energy content.

Since the energy content of a unit measure of CNG (standard cubic foot - scf) and gasoline (gallon) vary widely depending on the sample of fuel measured, the reference gallon of gasoline was determined to be Indolene, the gasoline used by EPA to certify emissions and fuel economy, with an energy content (lower heating value) of 114,118 BTU/gal. Work conducted by the Institute of Gas Technology and the Gas Research Institute (now combined into the Gas Technology Institute) surveyed 6811 samples of natural gas nationwide and concluded that the “average” natural gas in the US had an energy content (lower heating value) of 923.7 BTU/scf, and a density of 0.0458172 lbs/cubic foot. This translates 20,160.551 BTU/lb. Dividing gasoline’s 114,118 BTU/gal by natural gas’s 20,160.551 BTU/lb gives 5.660 lbs of natural gas = 1 GGE. Similar calculations determined that a gasoline liter equivalent of natural gas equals 0.678 kg of natural gas.

At its 79th annual meeting in July of 1994, NCWM adopted resolutions that:

“All natural gas kept, offered or exposed for sale or sold at retail as a vehicle fuel shall be in terms of the gasoline liter equivalent (GLE) or gasoline gallon equivalent (GGE), and

All retail natural gas dispensers shall be labeled with the conversion factor in terms of kilograms or pounds. The label shall be permanently and conspicuously displayed on the face of the dispenser and shall have either the statement “1 Gasoline Liter Equivalent (GLE) is equal to 0.678 kg of Natural Gas” or “1 Gasoline Gallon Equivalent (GGE) is equal to 5.660 lbs of Natural Gas” according to the method of sale used.”

These statements can be found in NIST Handbook 130^{*}, along with the definition of “natural gas” which seems to apply only to Compressed Natural Gas, not to Liquefied Natural Gas. Handbook 130, §§3.11 and 3.12 (Engine Fuels, Petroleum Products, and Automotive Lubricants Regulations) confirm that these requirements are for CNG, rather than LNG. Similar requirements and definitions are found in Handbook 44.

During the discussions it was recognized that, although diesel and gasoline are both sold in gallon units, a gallon of diesel fuel has substantially more energy content than a gallon of gasoline. While it is convenient to use the Gasoline Gallon Equivalent unit when comparing the cost and fuel economy of gasoline-powered light-duty vehicles to equivalent natural gas vehicles, a Diesel Gallon Equivalent unit would be more useful for operators of medium and heavy-duty (usually diesel powered) vehicles. However, in 1994, the NCWM working group “agreed to defer development of a “Diesel Gallon

* “Method of Sale Regulation,” §2.27

Equivalent” until the issues related to the ‘Gasoline Gallon Equivalent’ were decided by the NCWM and agreed to meet again if additional work is necessary.”** The issue of the formal definition a Diesel Gallon Equivalent (DGE) unit has not come before NCWM from that time until today, although the DGE is often used in the industry, defined as 6.31 lbs of natural gas.

Need for a Definition of a “Diesel Gallon Equivalent” Unit

Today there are an increasing number of commercial vehicles using natural gas as a fuel, to lower emissions and Greenhouse Gases, decrease America’s use of petroleum, and lower fuel costs (U.S. DOE Clean Cities Alternative Fuel Price Report for April 2012 shows in Table 2 ‘Overall Average Fuel Price on Energy-Equivalent Basis’ that diesel is priced at \$4.12/gal and CNG at \$2.32/gal http://www.afdc.energy.gov/afdc/pdfs/afpr_apr_12.pdf).

Since the NCWM’s working group deferred development of a DGE unit in 1994, there has been little call by the natural gas vehicle industry for the formalization of that unit in the sale of **Compressed** Natural Gas. However the use of **Liquefied** Natural Gas (LNG) as a motor fuel has been growing and there is significant interest in using the DGE as a unit for the sale of that fuel.

LNG as a motor fuel is used almost exclusively by commercial vehicles, most of which view diesel as the conventional alternative. Using the same logic as was used for the development of the GGE unit, the convenience of the retail customer comparing the cost and fuel economy of a natural gas vehicle to a comparable conventional vehicle, it makes sense for NCWM to now “officially” define the DGE.

Other than §3.12. Liquefied Natural Gas, in the Engine Fuels and Automotive Lubricants Regulation section of Handbook 130, we find no specific provisions in either Handbook 44 or Handbook 130 for the retail sale of LNG as a motor fuel. However LNG is sold in California and other states on a mass basis (by the pound), which allows for easy confirmation by weights and measures authorities. An “official” definition of the DGE as a specific mass of natural gas would allow states to easily move from retail sale by pound to retail sale by DGE, simplifying the sale process for the retail customer used to dealing with “gallons of diesel” as a fuel measure.

Therefore, at this time we are asking for a definition of the Diesel Gallon Equivalent (and Diesel Liter Equivalent) units by NCWM.

Justification of the Definition of a DGE as 6.312 Pounds of Natural Gas

Handbook 130 contains the following definitions of natural Gas as a vehicle fuel*:

Gasoline liter equivalent (GLE). – Gasoline liter equivalent (GLE) means
0.678 kg of natural gas.

Gasoline gallon equivalent (GGE). – Gasoline gallon equivalent (GGE) means
2.567 kg (5.660 lb) of natural gas.

** *Report of the 79th National Conference on Weights and Measures, 1994*, NIST Special Publication 870, p 214

* NIST handbook 130, 2006, Method of State Regulation, §§2.27.1.2 and 2.227.1.3; also Engine Fuels, Petroleum Products, and Automotive Lubricants Regulation, §§1.25 and 1.26.

As the NCWM working group recognized during its deliberations in 1993 on the Gasoline Gallon Equivalent unit, both gasoline and natural gas can vary in their BTU content from sample to sample. The working group determined the gasoline gallon (energy) equivalent based on a gallon of Indolene (114,118 BTU/gal – lower heating value) and a survey of 6811 natural gas samples nationwide with an average of 923.7 BTU/scf (lower heating value) and a density of 0.0458172 lbs/cubic foot. This equates to 20,160.551 BTU/lb. Dividing gasoline's 114.118 BTU/gal by natural gas's 20,160.551 BTU/lb gives 5.660 lbs of natural gas = 1 GGE. Similar calculations determined that a gasoline liter equivalent of natural gas equals 0.678 kg of natural gas.

Starting with 5.660 lbs of natural gas = 1 GGE and 0.678 kg of natural gas = 1 GLE, we can calculate the mass of natural gas necessary to make a DGE and a DLE by comparing the amount of energy in a gallon of diesel fuel to the amount of energy in a gallon of gasoline fuel and apply that ratio to scale up the masses of natural gas calculated for the GGE and GLE units.

Unfortunately it is no easier today than it was in 1993 to set one energy value as representative of a unit for all gasoline, (or diesel) fuel. EPA's certification fuel has likely changed in energy content since 1993, as both gasoline and diesel fuels have been modified for improved emissions.

We recommend using the most recent Department of Energy *Transportation Energy Data Book*^{*}, as an authoritative reference for both gasoline and diesel fuel energy values. Taking further surveys or basing our calculations on today's EPA certification fuel only delays our action, substantially increases costs, and, in the end, provides a limited potential increase in accuracy based on one point in time. Table B.4 of the *Transportation Energy Data Book*, on the heat content of fuels http://cta.ornl.gov/data/tedb30/Edition30_Full_Doc.pdf lists the net energy of gasoline as 115,400 BTU/Gal, and diesel as 128,700 BTU/Gal.

Therefore a Diesel Gallon Equivalent of natural gas is:

$$(128,700/115,400) \times 5.660 = 6.312 \text{ lb (2.863 kg)}$$

and a Diesel Liter Equivalent of natural gas is:

$$(128,700/115,400 \times 0.678 = 0.756 \text{ kg}$$

Prepared by:
Clean Vehicle Education Foundation
<http://www.cleanvehicle.org>

^{*} Stacy C. Davis and Susan W. Diegel, Oak Ridge National Laboratory, *Transportation Energy Data Book*, Edition 30, 2011, ORNL-6978, or <http://cta.ornl.gov/data/index.shtml>

Appendix B

Item 360-4 Draft Tentative Code Applicable to Weigh-In-Motion Systems Used for Vehicle Enforcement Screening

Section 2.25. Weigh-In-Motion Systems used for Vehicle Enforcement Screening – Draft Code

A. Application

- A.1. General.** – This code applies to systems used to weigh vehicles, while in motion, for the purpose of screening and sorting the vehicles based on the vehicle weight to determine if a static weighment is necessary.
- A.2.** The code does not apply to weighing systems intended for the collection of statistical traffic data.
- A.3.** The code is intended for field enforcement use only.
- A.4. Additional Code Requirements.** – In addition to the requirements of this code, Weigh-In-Motion Screening Systems shall meet the requirements of Section 1.10. General Code.

S. Specifications

S.1. Design of Indicating and Recording Elements and of Recorded Representations.

S.1.1. Ready Indication. – The system shall provide a means of verifying that the system is operational and ready for use.

S.1.2. Value of System Division Units. – The value of a system division “d” expressed in a unit of weight shall be equal to:

- (a) 1, 2, or 5; or
- (b) a decimal multiple or submultiple of 1, 2, or 5.

Examples: divisions may be 10, 20, 50, 100; or 0.01, 0.02, 0.05; or 0.1, 0.2, 0.5, etc.

S.1.2.1. Units of Measure. – The system shall indicate weight values using only a single unit of measure.

S.1.3. Value of Other Units of Measure.

S.1.3.1. Speed. – Vehicle speeds shall be measured in miles per hour or kilometers per hour.

S.1.3.2. Axle-Spacing (Length). – The center-to-center distance between any two successive axles shall be measured in feet and/or inches, or meters.

S.1.3.3. Vehicle Length. – If the system is capable of measuring the overall length of the vehicle, the length of the vehicle shall be measured in feet and/or inches, or meters.

S.1.4. Capacity Indication. – An indicating or recording element shall not display nor record any values greater than 105 % of the specified capacity of the load receiving element.

S.1.5. Identification of a Fault. – Fault conditions shall be presented to the operator in a clear and unambiguous means. The following fault conditions shall be identified:

- (a) Vehicle speed is below the minimum or above the maximum speed as specified.
- (b) The maximum number of vehicle axles as specified has been exceeded.
- (c) A change in vehicle speed greater than that specified has been detected.

S.1.6. Recorded Representations.

S.1.6.1. Values to be Recorded. – At a minimum, the following values shall be printed and/or stored electronically for each vehicle weighment:

- (a) transaction identification number;
- (b) lane identification (required if more than one lane at the site has the ability to weigh a vehicle in-motion);
- (c) vehicle speed;
- (d) number of axles;
- (e) weight of each axle;
- (f) identification and weight of axles groups;
- (g) axle spacing;
- (h) total vehicle weight;
- (i) all fault conditions that occurred during the weighing of the vehicle;
- (j) violations, as identified in paragraph S.2.1., that occurred during the weighing of the vehicle; and
- (k) time & date.

S.1.7. Value of the Indicated and Recorded System Division. – The value of the system's division size as recorded shall be the same as the division value indicated.

S.2. System Design Requirements.

S.2.1. Violation Parameters. – The instrument shall be capable of accepting user entered violation parameters for the following items:

- (a) single axle weight limit;
- (b) axle group weight limit;
- (c) gross vehicle weight; and
- (d) bridge formula load.

The instrument shall display and or record violation conditions when these parameters have been exceeded.

S.3. Design of Weighing Elements.

S.3.1. Multiple Load-Receiving Elements. – An instrument with a single indicating or recording element, or a combination indicating-recording element, that is coupled to two or more load-receiving elements with independent weighing systems, shall be provided with means to prohibit the activation of any load-receiving element (or elements) not in use, and shall be provided with automatic means to indicate clearly and definitely which load-receiving element (or elements) is in use.

S.4. Design of Weighing Devices, Accuracy Class.

S.4.1. Designation of Accuracy. – WIM Systems meeting the requirements of this code shall be designated as accuracy Class A.

S.5. Marking Requirements. – In addition to the marking requirements in G-S.1. Identification (except G-S.1.(e)), G-S.4. Interchange or Reversal of Parts, G-S.6. Marking Operational Controls, Indications, and Features, G-S.7. Lettering, and G-UR.2.1.1. Visibility of Identification. The system shall be marked with the following information:

- (a) Accuracy Class;
- (b) Value of the System Division “d”;
- (c) Operational Temperature Limits;
- (d) Number of Lanes;
- (e) Minimum and Maximum Vehicle Speed;
- (f) Maximum Number of Axles per Vehicle;
- (g) Maximum Change in Vehicle Speed during Weighment; and
- (h) Minimum and Maximum Load.

S.5.1. Location of Marking Information. – The marking information required in G-S.1. Identification of the General Code and S.5. shall be visible after installation. The information shall be marked on the system or recalled from an information screen.

N. Notes

N.1. Test Procedures.

N.1.1. Selection of Test Vehicles. – All dynamic testing associated with the procedures described in each of the subparagraphs of N.1.5 shall be performed with a minimum of two test vehicles.

- (a) The first test vehicle may be a two axle, six tire, single unit truck; a vehicle with two axles with the rear axle having dual wheels. The vehicle shall have a maximum Gross Vehicle Weight of 10 000 lbs.
- (b) The second test vehicle shall be a five axle, single trailer truck with a maximum Gross Vehicle Weight of 80,000 lbs.

Note: Consideration should be made for testing the systems using vehicles which are typical to the systems daily operation.

N.1.1.1. Weighing of Test Vehicles. – All test vehicles shall be weighed on a reference scale before being used to conduct the dynamic tests.

N.1.2. Test Loads.

N.1.2.1. Static Test Loads. – All static test loads shall use certified test weights.

N.1.2.2. Dynamic Test Loads. – Test vehicles used for dynamic testing shall be loaded to 85 % to 95 % of their maximum Gross Vehicle Weight. The “load” shall be non-shifting and shall be positioned to present as close as possible, an equal side-to-side load.

N.1.3. Reference Scale. – Each reference vehicle shall be weighed on a static scale meeting NIST Handbook 44, Class III L maintenance tolerances.

N.1.3.1. Location of a Reference Scale. – The location of the Reference Scale must be considered as vehicle weights will change due to fuel consumption.

N.1.4. Test Speeds. – All dynamic tests shall be conducted within 20 % below or at the posted speed limit.

N.1.5. Test Procedures.

N.1.5.1. Dynamic Load Test. – The dynamic test shall be conducted using the test vehicles defined in N.1.1. The test shall consist of a minimum of 20 runs for each test vehicle at the speed as stated in N.1.4. Test Speeds. The tolerance for each run shall be based on the percentage values specified in Table T.3.1. Tolerances for Accuracy Class A.

N.1.5.2. Axle Spacing Test. – The axle spacing test is a review of the displayed and/or recorded axle spacing distance of the test vehicles. The tolerance value for each distance shall be based on the tolerance value specified in T.3.2. Axle Spacing Tolerance.

N.1.5.3. Position of Vehicle during Test Runs. – During the conduct of the dynamic testing the vehicle shall adjust its position along the width of the sensor from one run to the next but ensuring that the vehicle stays within the defined roadway. The test shall be conducted with 10 runs in the center, 5 runs on the right side, and five runs on the left side. All weightings shall be within tolerance.

T. Tolerances

T.1. Principles.

T.1.1. Design. – The tolerance for a weigh-in-motion system is a performance requirement independent of the design principle used.

T.2. Tolerance Application.

T.2.1. General. – The tolerance values are positive (+) and negative (-). No more than 5% of each test shall be outside the applicable tolerances

T.3. Tolerance Values for Accuracy Class A.

T.3.1. Tolerance Values for Dynamic Testing. – The tolerance values applicable during dynamic load testing are as specified in Table T.3.1. Tolerances for Accuracy Class A.

Table T.3.1. – Tolerances for Accuracy Class A	
Load Description	Tolerance as a Percentage of Applied Test Load
Axle Load	20 %
Axle Group Load	15 %
Gross Vehicle Weight	10 %

T.3.2. Axle Spacing Tolerance. – The tolerance value applied to the axle spacing measurement shall be ± 0.5 ft (0.15 m).

T.4. Influence Factors. – The following factors are applicable to tests conducted under controlled conditions only.

T.4.1. Temperature. – Systems shall satisfy the tolerance requirements under all operating temperature unless a limited operating temperature range is specified by the manufacturer.

T.5. Radio Frequency Interference (RFI) and Other Electromagnetic Interference Susceptibility. – The difference between the weight indication due to the disturbance and the weight indication without the disturbance shall not exceed the tolerance value as stated in Table T.3.1. Tolerances for Accuracy Class A.

UR. User Requirements

UR.1. Selection Requirements. – Equipment shall be suitable for the service in which it is used with respect to elements of its design, including but not limited to, its capacity, number of scale divisions, value of the scale division or verification scale division and minimum capacity.

UR.2. User Location Conditions and Maintenance. – The system shall be installed and maintained as defined in the manufacturer’s recommendation.

UR.2.1. System Modification. – The dimensions (e.g., length, width, thickness, etc.) of the load receiving element of a system shall not be changed beyond the manufacturer’s specifications, nor shall the capacity of a scale be increased beyond its design capacity by replacing or modifying the original primary indicating or recording element with one of a higher capacity, except when the modification has been approved by a competent engineering authority, preferably that of the engineering department of the manufacturer of the system, and by the weights and measures authority having jurisdiction over the system.

UR.2.2. Foundation, Supports, and Clearance. – The foundation and supports shall be such as to provide strength, rigidity, and permanence of all components.

On load-receiving elements which use moving parts for determining the load value, clearance shall be provided around all live parts to the extent that no contacts may result when the load-receiving element is empty, nor throughout the weighing range of the system.

UR.2.3. Access to Weighing Elements. – If necessary, adequate provision shall be made for inspection and maintenance of the weighing elements.

UR.3. Maximum Load. – A system shall not be used to weigh a load of more than the marked maximum load of the system.

The following are proposed definitions to be added to NIST Handbook 44, Appendix D to support the Weigh-In-Motion Systems used for Vehicle Enforcement Screening – Draft Code.

weigh-in-motion (WIM). – A process of estimating a moving vehicle’s gross weight and the portion of that weight that is carried by each wheel, axle, or axle group, or combination thereof, by measurement and analysis of dynamic vehicle tire forces.

axle. – The axis oriented transversely to the nominal direction of vehicle motion, and extending the full width of the vehicle, about which the wheel(s) at both ends rotate.

axle-group load. – The sum of all tire loads of the wheels on a group of adjacent axles; a portion of the gross-vehicle weight.

axle load. – The sum of all tire loads of the wheels on an axle; a portion of the gross-vehicle weight.

axle spacing. – The distance between the centers of any two axles. When specifying axle spacing, you also need to identify the axles used.

single-axle load. – The load transmitted to the road surface by the tires lying on the same longitudinal axis (that axis transverse to the movement of the vehicle and about which the wheels rotate).

tandem-axle load. – The load transmitted to the road surface by the tires of two single-axles lying on the same longitudinal axis (that axis transverse to the movement of the vehicle and about which the wheels rotate).

triple-axle load. – The load transmitted to the road surface by the tires of three single-axles lying on the same longitudinal axis (that axis transverse to the movement of the vehicle and about which the wheels rotate).

Weigh-in-Motion Screening Scale. – A WIM system used to identify potentially overweight vehicles.

wheel weight. – The weight value of any single or set of wheels on one side of a vehicle on a single axle.

WIM System. – A set of sensors and supporting instruments that measure the presence of a moving vehicle and the related dynamic tire forces at specified locations with respect to time; estimate tire loads; calculate speed, axle spacing, vehicle class according to axle arrangement, and other parameters concerning the vehicle; and process, display, store, and transmit this information. This standard applies only to highway vehicles.

Report of the Professional Development Committee (PDC)

Julie Quinn, Committee Chair
Minnesota

400 INTRODUCTION

This is the report of the Professional Development Committee (hereinafter referred to as the “Committee” or PDC) for the 98th Annual Meeting of the National Conference on Weights and Measures (NCWM). This report is based on the Interim Report offered in the NCWM Publication 16, testimony heard at public hearings, comments received from the regional weights and measures associations and other parties, the addendum sheets issued at the Annual Meeting, and actions taken by the membership at the voting session of the Annual Meeting. The informational items presented below were adopted as presented when the Committee’s report was approved.

Table A identifies the agenda and appendix items. Agenda items are identified in the Report by Reference Key Number, Item Title, and Page Number. Item numbers are those assigned in the Interim Meeting agenda. A Voting item is indicated with a “V” after the item number. An item marked with an “I” after the reference key number is an Informational item. An item marked with a “D” after the reference key number is a Developing item. The developing designation indicates an item has merit; however, the item was returned to the submitter for further development before any action can be taken at the national level. Suggested revisions are shown in bold face print by ~~striking out~~ information to be deleted and underlining information to be added. Table B lists the results of any voting items.

Note: It is the policy of the National Institute of Standards and Technology (NIST) to use metric units of measurement in all of its publications; however, recommendations received by NCWM technical committees and regional weights and measures associations have been printed in this publication as submitted. Therefore, the report may contain references in inch-pound units.

Subject Series List

Introduction 400 Series
Education 410 Series
Program Management 420 Series

Table A
Table of Contents

Reference Key	Title of Item	PDC Page
400	INTRODUCTION	1
410	EDUCATION	2
410-1	I Professional Certification Program.....	3
410-2	I Training	7
410-3	I Instructor Improvement	7
410-4	I Recommended Topics for Conference Training.....	7
420	PROGRAM MANAGEMENT	9
420-1	I Safety Awareness	9
420-2	I PDC Publication	10

Appendices

A — Professional Certification Program Curriculum Work Plan A1

B — History of Professional Certification Program..... B1

C — History of Instructor Improvement C1

Table B
Voting Results

<i>Reference Key Number</i>	<i>House of State Representatives</i>		<i>House of Delegates</i>		<i>Results</i>
	<i>Yeas</i>	<i>Nays</i>	<i>Yeas</i>	<i>Nays</i>	
No Voting items					

Table C
Glossary of Acronyms and Terms

Acronym	Term	Acronym	Term
ADDIE	Analysis, Design, Development, Implementation, and Evaluation	NEWMA	Northeastern Weights and Measures Association
ANSI	American National Standards Institute	NIST	National Institute of Standards and Technology
BOK	Body of Knowledge	OWM	Office of Weights and Measures
CWMA	Central Weights and Measures Association	PDC	Professional Development Committee
ISO	International Standardization Organization	RSA	Registered Service Agents
ICE	Institute for Credentialing Excellence	SME	Subject Matter Expert
LPG	Liquefied Petroleum Gas	SWMA	Southern Weights and Measures Association
NCWM	National Conference on Weights and Measures	WWMA	Western Weights and Measures Association

Details of All Items
(In order by Reference Key)

410 EDUCATION

410-1 I Professional Certification Program

Report Cleanup:

The PDC archive is under construction on the new NCWM website. Anyone interested in seeing past reports should look for the report in the NCWM archives at <http://www.ncwm.net/meetings/annual/archive>.

2013 Interim Topics:

- **Basic Proficiency Exams on NCWM Test Site**

The Committee heard comments in 2012 asking whether it was possible to use the NCWM test site to offer basic proficiency exams. At the 2013 Interim, Ms. Carol Hockert reported that NIST, OWM will be using the NCWM test site to administer proficiency tests, which will be used as qualifying prerequisites for OWM courses. The tests will be open to members and non-members alike at no fee. The first exam, which will be on the NCWM test site, will be a NIST Handbook 44 (*Standards, Tolerances, and Other Technical Requirements for Weighing and Measuring Devices*) self-study course exam. Contact NIST, OWM for further information.

Mr. Don Onwiler confirmed that membership is not necessary to take OWM proficiency tests.

2013 Annual Meeting: Ms. Carol Hockert reported that the NIST, OWM currently requires a prerequisite mathematics test for applicants to their Fundamentals of Metrology training course. They intend to start offering that test online through the NCWM test site. This mathematics exam may also be used by weights and measures jurisdictions to screen job applicants. OWM also intends to provide a NIST Handbook 44 test to compliment the NIST Handbook 44 self-study course. These tests will be free and available to all NCWM members and non-members alike.

- **Feedback from Registered Service Agents (RSAs) after taking Certification Exam**

A small number of registered service agents (RSAs) were asked in 2012 to take the certification exams and provide the Committee with feedback on the suitability of the certification exams for RSAs. The Committee reported that it had received the following comments from the RSAs who had taken the exams:

- RSAs advised test-takers know test taking strategies
 - First answer easy questions;
 - Then look up skipped questions;
 - If time allows, look up answers you thought were easy.
- RSAs question the appropriateness of some of the fundamental questions. For example, questions on NCWM voting bylaws.
 - A comment was heard from the floor from one state director that nuances of the bylaws were probably not even useful to regulatory officials at the field level, let alone RSAs. The Director suggested that questions should be geared toward fundamentals, general code applications, and field applications.
 - The Committee recommends that the questions be sent back to the coordinator and SMEs for review as to their appropriateness.

- RSAs thought that it took too long to get a password to take test.
 - The Committee reported that password generation will be automated with the completion of the NCWM website upgrade.
- RSAs would like feedback for test-takers on the exam sections which they failed.
 - The Committee reported that they will continue to keep that in mind if it becomes technologically possible to do so.
- RSAs would like to know where to find information on how to study for the exams.
 - The Committee presented a slide show to point to the curriculum hotlinks embedded in the course descriptions which appear at the certification site. (ncwm.net/member/tests)

2013 Annual Meeting: The Committee reported on their response to issues raised by a small number of RSAs who volunteered to take the test and provide feedback:

- Corrections were made to the answer key on several questions, and all failing tests were reviewed to see if those questions affected the final results. Three people were notified that they had, in fact, passed their exams and would be issued certificates as a result of this review.
- Test passwords are now auto-generated as part of the test purchase process. Tests are free to NCWM members. For non-members, tests may be purchased using a credit card, a check, or a purchase order (P.O.). For those people wishing to purchase using a P.O., select the check option and then contact the NCWM office. Anyone wishing to purchase a block of tests for a group, or jurisdictions who wish to proctor the exams, should contact the NCWM directly instead of purchasing through the website.
- The Committee will continue to keep open the possibility that test section results might someday be reportable to test takers, but the results of specific questions will not be made available in order to safeguard the integrity of the tests.
- The Committee demonstrated how to access information about the tests and curriculum modules on the new NCWM website, as well as how to purchase the exams.
- The suggestion was made from the floor that the Committee poll jurisdictions to find out if any had 100 % certification of their inspectors on any exam. Of those present in the room:
 - Thirteen states, and one service company reported that they had set the goal for 100 % certification;
 - Three states reported that they had already achieved 100 % certification in at least one discipline;
 - Nine states reported setting a goal of having RSAs certified as part of their permitting process;
 - No state reported that they had already implemented a requirement that RSAs have professional certification.
- A question was asked about what time commitment is asked of someone volunteering to be a subject matter expert (SME). The answer was approximately 20 hours over six to eight months. It is not necessary to be a trainer or a manager to be an SME. This is an excellent way to develop senior investigators who may become trainers in the future. This is also an opportunity where retirees can contribute their skills and experience. Industry participation is encouraged.

- In response to a question from the floor, the Committee reported that there is no conflict of interest if trainers wish to participate as SME because they are only exposed to a small portion of the test question bank, and their agreement with the NCWM is that the questions they see are the property of the NCWM and may not be used in their own training programs.

- **Status of Current tests**

Current tests – RMFD, Small Capacity Retail Scales, Basic Package Checking.

The Committee reported that exam statistics show steady improvement over time, indicating that much of the problem with passing the tests has to do with a need to acclimate to on-line testing.

Retail Motor Fuel Devices	FY2011	FY 2012¹	FY2013 to Date ¹	Total
# of Registrants	76	107	5	188
# of Exams Taken	189	145	7	341
# of Certificates Issued	45	83	6	134
% certificates per registrants	59.2%	78.3%	100.0%	71.3%

Note 1: One person registered in FY2012 for RMFD test but did not test until FY2013

Pack Checking		FY 2012	FY2013 to Date	Total
# of Registrants		15	37	52
# of Exams Taken		23	33	56
# of Certificates Issued		5	19	24
% certificates per registrants		33.3%	51.4%	46.2%

Small Scales		FY 2012	FY2013 to Date	Total
# of Registrants		17	50	67
# of Exams Taken		15	100	115
# of Certificates Issued		6	34	40
% certificates per registrants		35.3%	68.0%	59.7%

The VTM exam is in development now. SMEs are currently writing the questions. The Certification Coordinator is currently seeking SMEs for Medium Capacity Scales and Large Capacity Scales Class III and IIIL. The Committee thanks those who have already volunteered to be SMEs.

Package Checking Basic

D'Arcy, Carlos, FL
 Wilson, Peter, VA
 Gurney, Brett, UT
 Chesser, Tim, AR
 Merritt, Kevin, ID
 Shultz, Steve, NV

Small Capacity Scales Class III

Smith, Dan, AK
 D'Arcy, Carlos, FL
 Wilson, Peter, VA
 Gurney, Brett, UT
 Chesser, Tim, AR
 Merritt, Kevin, ID

Package Checking Basic

McGee, Robert, SC
Hicks, Tyler, OK
Johnson, Ray, NM
Paquette, Marc, VT
Tubacki, Jeff, IL
Dillibaugh, John, PA
Miller, Rachelle, WI
Feagan, Bruce, WA
Butcher, Ken, NIST OWM

Small Capacity Scales Class III

Shultz, Steve, NV
Stokes, John, SC
McGee, Robert, SC
Hicks, Tyler, OK
Johnson, Ray, NM
Paquette, Marc, VT
Tubacki, Jeff, IL
Dillibaugh, John, PA
Miller, Rachelle, WI
Feagan, Bruce, WA

The Committee also wanted to assure members that SMEs will not compromise their ability to be trainers as no SME will be allowed to have access to more than 25 % of the questions.

Mr. Onwiler made a comment that this restriction on access to the test questions was an important part of maintaining the integrity of the exam process as the certification program moves toward formal accreditation. Eventually exam questions may need to be copyrighted. SMEs should note that they should modify test questions before submitting them to the certification coordinator if they wish to continue to use those questions in their own exams.

• **Certification Coordinator Reported on Exam Question Pass/Fail Statistics**

The Certification Coordinator reviewed the exam question statistics for each exam:

- Statistics indicate that the questions and time required to answer them are generally appropriate.
- He explained the significance of differentiating questions that took a long time to answer and had low passing rates among those who failed the test, but had high passing rates among those who passed the tests. These questions separate those who really know their stuff from those who do not.
- Exam statistics also indicated that most test-takers had more difficulty with general questions and fundamental questions than they did with device specific questions. This indicates that there is a training imbalance between general principles and device specifics. He noted that part one of every exam covers the general code and fundamental considerations.
- There are questions in the small capacity scale exam and the package checking exam which will be reviewed by the SMEs to check appropriateness and wording.

An industry representative wanted to know how industry could help improve the exams. The Committee responded:

- Take the exams and give the Committee feedback;
- Participate as SMEs in developing tests;
- Be a resource to provide training materials; and
- Help with instructor improvement, particularly relating to training Registered Service Agents (RSAs).

410-2 I Training

The Committee recommended that a new item dealing with training be inserted and subsequent item numbering be adjusted. The purpose of this item is to share information gleaned from the certification test statistics regarding broad training needs, and to serve as a link to various training materials on the web. Eventually, it can become a home for the training material program currently under development by the NCWM Board of Directors.

The Committee reported that the Board of Directors is assembling a new work group to be headed by Mr. Michael Cleary, former Director of the California Division of Measurement Standards. The function of the work group will be to develop guidance on the scope of training for weights and measures officials and will report to the PDC. Anyone interested in serving on this work group should contact the NCWM Board of Directors.

410-3 I Instructor Improvement

Report Cleanup:

2013 Interim Meeting: The Committee agreed to move the historical data in the current item to Appendix C, with the intention of moving it into the Committee archives at the 2014 Interim. Moving forward, historical information will be archived and items will contain only current action items.

Current Items:

The Committee called on Ms. Hockert to discuss NIST, OWM's new regional trainer program. Ms. Hockert reported that NIST, OWM is looking for a way to increase the number of trainers available to teach OWM courses. OWM will be hosting a Train-the-Trainer course in April 2013 with the intention of developing a pool of weights & measures officials capable of offering NIST, OWM training at the regional level. The training is free, and OWM asks for a minimum commitment from each participant of leading one to two training courses with a NIST, OWM trainer in the subsequent year. Expenses involved with teaching the course(s) would be covered by NCWM through an OWM grant.

2013 Annual Meeting: Ms. Hockert reported that the NIST, OWM Train-the-Trainer program had already trained 20 weights and measures officials from 17 states on techniques for training adult learners. Nine NIST courses will be taking place between July and November, at which those people will be assisting and observing. The OWM is looking to increase the number of people who receive that basic training, and also to add continuing training for those people who have taken the first course. The ultimate goal is to have many people around the country capable of leading training on NIST technical courses. In response to questions from the PDC, the Associate Membership Committee clarified that under their current bylaws funds are available to bring trainers to jurisdictions but not to send individuals to training – even to courses meant to train trainers.

410-4 I Recommended Topics for Conference Training

Source:

Carryover Item 401-5 (This item originated from the Committee and first appeared on its agenda in 2003.)

Background/Discussion:

The Board of Directors has charged the Committee with recommending appropriate topics for the technical sessions at future Annual Meetings. The Board of Directors asked the PDC to review and prioritize possible presentations and submit those to NCWM Chairman. The Chairman will coordinate with NCWM staff to secure presenters and schedule the sessions.

The Committee acknowledged the continued interest in having a presentation on Making Sense of Electronic Receipts and is seeking assistance in identifying a suitable presenter on the topic. A comment was heard from the floor that Price Posting on Retail Motor Fuel Devices should be added to the list so that the new changes can be explained.

The Committee would like to recommend that the regional associations and NCWM consider offering training on:

- Making Sense of Electronic Receipts;
- Training the Trainer in Adult Learning Techniques;
- Ethics for weights & measures officials; and
- Data privacy issues faced by weights & measures officials.

The PDC continues to carry the following list and recommends these topics for possible training seminars, roundtables, or symposia for presentation at future NCWM meetings:

- Alternative Fuels Issues (Fuel Volatility, Ethanol Blending, and Biodiesel Blend);
- Ergonomics (including Proper Lifting Techniques, Back and Stress Techniques, and Office Ergonomics);
- Public Relations (specifically dealing with aggressive/angry people) (recommended by the SWMA);
- General Safety Issues (recommended by the WWMA);
- Defensive Driving (recommended by the WWMA);
- Administrative Civil Penalty Process (recommended by the WWMA);
- Price Verification (recommended by the WWMA);
- Customer Service (recommended by the WWMA);
- Moisture Loss;
- Documenting Investigations for Court Proceedings;
- Honing Presentation Skills;
- Emerging Issues;
- Implementing New RMFD Price Posting and Computing Capability Revisions(recommended by the WWMA);
- Fundamentals of the National Type Evaluation Program (recommended by the WWMA);
- Electric Vehicles: Commercial Devices, Method of Sale, Advertising and Labeling (recommended by the WWMA);
- Understanding the International Weights and Measures Standards Development System (recommended by the WWMA); and
- Crane Operation and Safety (recommended by the NEWMA).

The following is a list of recent presentations, available at www.ncwm.net/meetings/annual/archive:

- Economic Justification and Demonstrating Value of Weights and Measures Grand Ballroom (Mr. Tim Chesser, Arkansas Bureau of Standards, 2012);
- Conducting Effective Marketplace Surveys and Investigations Grand Ballroom (Ms. Judy Cardin, Wisconsin Weights and Measures, 2012);
- Public Relations and Customer Service as Regulators Grand Ballroom (Mr. Doug Deiman, Alaska, 2012);
- An Overview of Unit Pricing in the United States (Mr. David Sefcik, NIST, 2011);
- Grocery Unit Pricing in Australia (Mr. Ian Jarratt, 2011);
- Grocery Unit Pricing in Canada (Mr. Ian Jarratt, 2011);
- The U.S. Hydrogen Measuring System: The Turning Point? (Ms. Kristin Macey, 2011);
- Corrosion in Ultra Low Sulfur Diesel Underground Storage Systems (Mr. Prentiss Searles and Ms. Lorri Grainawi, 2010);
- Risk-Based Inspection Schemes (Mr. Henry Oppermann, 2010);
- Diesel Exhaust Fluid (DEF) (Mr. Gordon Johnson and Mr. Randy Moses. 2009);
- Fuel Volatility and Ethanol Blending (Mr. Jim McGetrick, 2009);
- Investigative Techniques (Mr. Michael Cleary, 2009);
- Automatic Temperature Compensation (ATC) Field Test Procedures;
- Elements of an Effective Safety and Health Program (Mr. Dan Whipple, 2008);
- Analyzing Temperature Compensation Data (Mr. Henry Oppermann and Mr. Steven Malone, 2007);
- The Great Temperature Compensation Debate (Mr. Ross Andersen, 2007);
- NIST Handbook 44 Scale Code Tare Changes (Mr. Steve Cook).

No comments were heard.

420 PROGRAM MANAGEMENT

420-1 I Safety Awareness

Source:

Carryover Item 402-1 (This item originated from the Committee and first appeared on its agenda in 2003.)

Background/Discussion:

In the past, the Committee's responsibility extended to the identification of safety issues in the weights and measures field and included efforts to increase safety awareness. Jurisdictions are encouraged to send their safety reports and issues to their regional safety liaison, who in turn will forward them to the PDC. Below is a list of the Regional Safety Liaisons. Regional Associations should keep the Committee updated on current liaison assignments.

Central Weights and Measures Association (CWMA):
Ms. Julie Quinn, Minnesota Weights and Measures Division

Northeastern Weights and Measures Association (NEWMA):
Mr. Michael Sikula, New York Bureau of Weights and Measures

Southern Weights and Measures Association (SWMA):
Mr. Matthew Curran, Florida Department of Agriculture and Consumer Services

Western Weights and Measures Association (WWMA):
Mr. Douglas Deiman, Alaska Division of Measurement Standards/CVE

The Committee will continue asking the regions to prepare articles for the NCWM Newsletter and has revised the schedule as follows for future issues. The Committee plans to notify the Regional Safety Liaisons as their assignment date approaches.

Region	Issue	Article Deadline	Published
SWMA	2013, Issue 3	16-Jul-13	September
WWMA	2014, Issue 1	18-Jan-14	February
CWMA	2014, Issue 2	16-Apr-14	May
NEWMA	2014, Issue 3	17-Jul-14	September

E-mail all articles to NCWM headquarters at info@ncwm.net.

The Committee would like to thank those persons who submitted safety related articles to the NCWM Newsletter. In particular, the Committee recognizes the contributors for the 2012 NCWM Newsletters.

- Safe Fueling and Gasoline Handling Guidelines NEVER COMPROMISE SAFETY!, 2012 Issue 2 (Mr. Steve Hadder, Florida)
- Working in Confined Spaces, 2012 Issue 2 (Mr. Douglas Deiman, Alaska)

The Committee asks for suggestions for safety articles that people would like to see in future newsletters and/or safety issues that need to be addressed immediately. The PDC reminds regional associations to check the submission deadlines for their upcoming article assignments. Send completed articles to NCWM headquarters by the submission deadline.

The Committee supports the recommendation made at the 2012 NCWM Annual Meeting that the safety articles in the NCWM Newsletters be extracted and compiled in one central location on the NCWM website.

An industry representative commented that this item is being underutilized and he urges everyone to give more attention to this item in the future. A state official made the suggestion that the Committee develop an anonymous form for people to report not only incidents but also near-misses.

420-2 I PDC Publication

Background/Discussion:

The NCWM website is being redesigned. The FAQ document presented at the 2012 Annual Meeting will be added to the website at the time of the update. The Committee will review relevant documents when the update is

complete to ensure that interested parties can easily find and utilize the materials. The three main sections of material include:

1. **Committee Active Working Documents** – includes active documents describing the developing professional certification program, the curriculum plan, Body of Knowledge (BOK) documents currently under development and open for comment (i.e., prior to release of a certification exam, program guidelines and administrative procedures);
2. **Professional Certification Documents** – includes the certification exam shopping page, exam descriptions, related BOK documents, aids to taking the certification exams;
3. **Committee Archives** – includes archive of historical documents that provide insight into the evolution of the Committee since inception and evolution of the Professional Certification Program. Interested parties should also refer to meeting archives at www.ncwm.net/meetings/annual/archive.

In addition, the Committee believes it is vital to move forward with a more formal set of administrative procedures for running a credible certification program. The Committee will make efforts to continue the work of Mr. Sikula (New York) at the request of the Board of Directors, to document our procedures following International Standardization Organization (ISO) 17024 Guidelines for Certification Bodies. The Board of Directors is also considering alternative ANSI standards. The Committee will be working with the Board of Directors on this project. NCWM management has ultimate responsibility for contracting with the testing service, policy issues, and staffing (both headquarters staff and the Certification Coordinator).

Ms. Julie Quinn, Minnesota | Committee Chair
Mr. Dale Saunders, Virginia | Member
Ms. Cheryl Ayer, New Hampshire | Member
Ms. Kristin Macey, California | Member
Mr. Stacy Carlsen, Marin County, California | Member
Mr. Steven Grabski, Walmart Stores, Inc. | Associate Membership Representative

Mr. Ross Andersen | Certification Coordinator

Professional Development Committee

THIS PAGE INTENTIONALLY LEFT BLANK

Appendix A

Professional Certification Program Curriculum Work Plan

Revised January 2010

Segment/Subject

Level 1/Level 2/Level 3

1. Fundamentals of Weights and Measures

- 1.1. Introduction to Weights and Measures Programs
- 1.2. Weights and Measures Laws and Regulations
- 1.3. Field Standards and Test Equipment
- 1.4. State Program Scope and Overview
- 1.5. Enforcement Powers

2. Weights and Measures Administration

- 2.1. Fundamentals of Weights and Measures Administration (Commercial System, Powers and Duties, etc.)
- 2.2. Administration Functions (Personnel, Management, Budget, Safety, etc.)
- 2.3. Legislation and Regulations (Legal Considerations, Interaction with Legislature, Stakeholders, Industry, etc.)
- 2.4. Regulatory Control (Device Inspection, Commodities, Complaints)
- 2.5. Laboratory Metrology Administration (Purpose of Laboratory, Responsibilities of Metrologist, NIST Expectations for Recognition of Laboratory, Quality System, Training Requirements, etc.)
- 2.6. Public Relations and Communications (Publicity, Public Relations, Communications)

3. Laboratory Metrology

- 3.1. NIST Basic Metrology
- 3.2. NIST Intermediate Metrology
- 3.3. NIST Advanced Metrology

4. Device Control Program

- 4.1. Safety Considerations
- 4.2. NIST Handbook 44 – Introduction to Device Control
- 4.3. Weighing Systems, General
 - 4.3.1. Static Electronic Weighing Systems, General
 - 4.3.2. Static Mechanical and Hybrid Weighing Systems, General
 - 4.3.3. Dynamic Weighing Systems, General
 - 4.3.4. Precision Weighing Systems Class I and II
 - 4.3.5. Small Capacity Weighing Systems Class III
 - 4.3.6. Medium Capacity Weighing Systems Class III
 - 4.3.7. Large Capacity Class III and III L Weighing Systems (Vehicle and Livestock)
 - 4.3.8. Large Capacity Class III and III L Weighing Systems - Advanced
 - 4.3.9. Railroad Track Weighing Systems
 - 4.3.10. In-Motion Railroad Track Weighing Systems
 - 4.3.11. Hopper Weighing Systems
 - 4.3.12. Automatic Bulk Weighing Systems
 - 4.3.13. Automatic Weighing Systems
 - 4.3.14. Belt Conveyor Weighing Systems
 - 4.3.15. In-Motion Monorail Weighing Systems
 - 4.3.16. Point-of-Sale Weighing Systems
 - 4.3.17. Other Specialty Weighing Systems
- 4.4. Dynamic Measuring Systems – General
 - 4.4.1. Retail Motor Fuel Dispensers

- 4.4.2. Loading Rack and Other Stationary Metering Systems
- 4.4.3. Loading Rack and Other Stationary Metering Systems – Advanced
- 4.4.4. Vehicle-Tank Meter Systems
- 4.4.5. Vehicle-Tank Meter Systems – Advanced
- 4.4.6. Milk Metering Systems
- 4.4.7. Water Meters
- 4.4.8. Liquefied Petroleum Gas (LPG) / Anhydrous Ammonia Liquid Metering Systems
- 4.4.9. LPG/Anhydrous Ammonia Liquid Metering Systems – Advanced
- 4.4.10. LPG Vapor Meter Systems
- 4.4.11. Mass Flow Metering Systems
- 4.4.12. Other Metering Systems (Cryogenics, Carbon Dioxide, etc.)
- 4.5. Static Volume Measuring Systems – General
 - 4.5.1. Liquid Measures
 - 4.5.2. Farm Milk Tanks
 - 4.5.3. Dry Measures
- 4.6. Other Measuring Systems
 - 4.6.1. Taximeters and Odometers
 - 4.6.2. Wire and Cordage Measuring Systems
 - 4.6.3. Linear Measures
 - 4.6.4. Timing Devices
 - 4.6.5. Weights
 - 4.6.6. Multiple Dimension Measuring Systems
- 4.7. Quality Measuring Systems
 - 4.7.1. Grain Moisture Meters
 - 4.7.2. NIR Grain Analyzers
 - 4.7.3. Carcass Evaluation Systems
- 5. Market Practices, Laws and Regulations (NIST Handbook 130) and Commodities (NIST Handbook 133)**
 - 5.1. Safety Considerations – Market Practices, NIST Handbook 130, NIST Handbook 133
 - 5.2. NIST Handbook 130 – Laws and Regulations
 - 5.2.1. NIST Handbook 130 – General Provisions
 - 5.2.2. Packaging and Labeling Regulations
 - 5.2.3. Method of Sale Regulations
 - 5.2.4. Quality of Automotive Fuels and Lubricants
 - 5.2.5. Price Verification
 - 5.3. NIST Handbook 133 – Package Net Contents Control
 - 5.3.1. Commodities – General
 - 5.3.2. Packages Labeled by Weight, Standard and Random
 - 5.3.3. Packages Labeled by Weight, Special Commodities
 - 5.3.4. Packages Labeled by Volume (Volumetric and Gravimetric Testing)
 - 5.3.5. Packages Labeled by Volume, Special
 - 5.3.6. Packages Labeled by Length/Area/Thickness
 - 5.3.7. Packages Labeled by Count
 - 5.3.8. Other Package Types
 - 5.4. Test Purchases
 - 5.5. E-Commerce

Note: Initial Verification has been intentionally been left off this listing and will be addressed later.

Appendix B

History of Professional Certification Program

Source:

Carryover Item 401-1 (This item originated from the Committee and first appeared on its Agenda in 2003 and has undergone continuing development.) The numbering change reflects harmonization in all NCWM reports. Copies of reports from recent years are also available on the website under Interim and Annual Meeting archives pages.

Background/Discussion:

It is important that users of the Professional Certification Program understand how the pieces fit together and form a coherent system. To illustrate the relationships the Committee can describe the system as a triangle of interdependent parts (see diagram below). The standards come in the form of goals with measureable learning objectives. The education part involves training provided to help the candidate reach the desired level of proficiency for each of the learning objectives. The certification involves an assessment of proficiency that measures whether or not the objectives have been met.

Certification Triangle

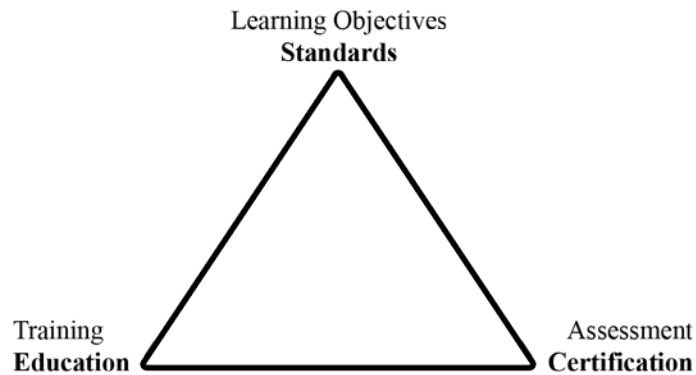

The Committee has until now focused attention on the standards and the certification pieces in the triangle as illustrated in the following flowcharts.

Standard Subsystem

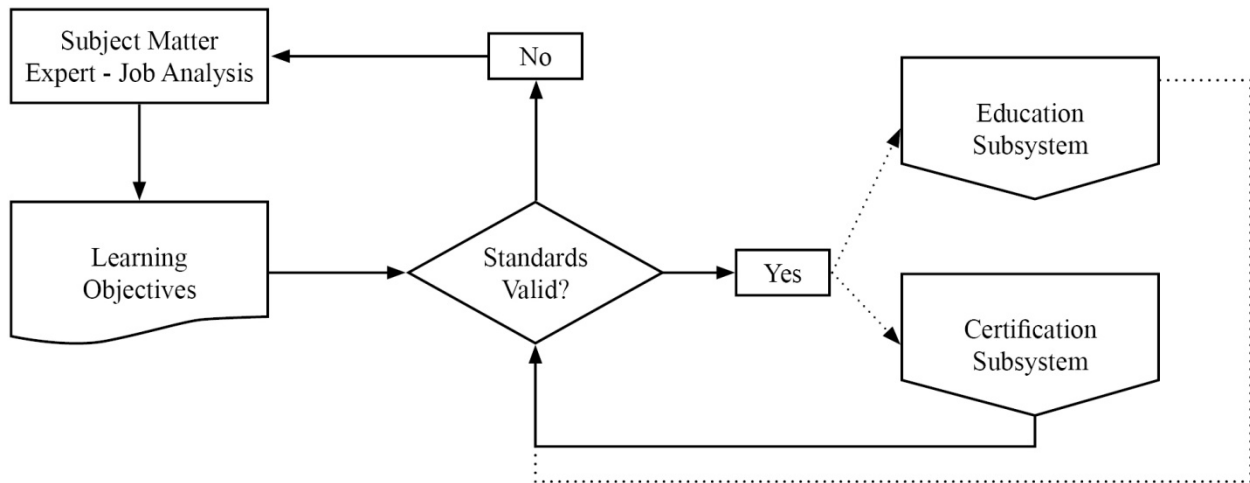

Certification Subsystem

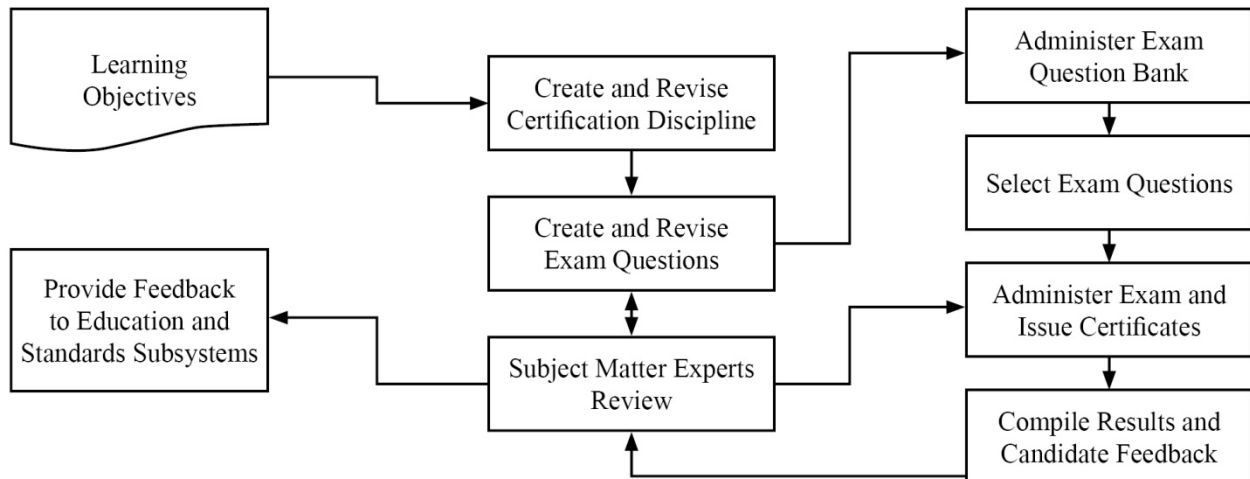

The Committee has described this work in a number of documents. In those documents the Committee is using terminology consistent with current usage in the education and certification field. The following important terms will be used throughout the Committee’s work on the subject.

Body of Knowledge (BOK) – refers broadly to the knowledge and skills required to function as a weights and measures professional. The term may refer broadly to the entire scope of knowledge and skills required within the profession or in a more directed manner to any selected subset for which the particular person is responsible. The BOK describes what you expect the weights and measures professional to achieve as opposed to how he/she will achieve it. To make the BOK more manageable in administration of the Professional Certification Program, it will be subdivided into modules in a tree-like structure moving from general knowledge and skills to more specific.

Module – refers to a group of related subject materials within the BOK. The module contains the articulated learning objectives for the subject area. Each module is considered a single, self-contained course of study. However, a broader course may span multiple modules and specific training may include only part of a module or parts of multiple modules. The PDC has created a standard format to create modules for the Professional Certification Program. The Committee has also created the Curriculum Outline and work plans to help manage the work activities within the program to create the many modules necessary to cover the entire profession.

Learning Objective – refers to the articulation of expectations of performance in measureable terms. Learning objectives are stated using active terms to be precise and measureable. There are two types of learning objectives, a terminal objective and an enabling objective. Terminal objectives state broadly the expectation of performance. The enabling objectives state the specific parts or steps required to demonstrate competence. The PDC has developed a guide to writing the learning objectives for both terminal and enabling which include the active verbs associated with the cognitive levels in Bloom’s Taxonomy. In training, the instructor will typically choose learning activities to explore each of the enabling objectives in an attempt to reach the terminal objective. In assessment, the questions will typically test for competence in each of the enabling objectives to demonstrate that the terminal objectives have been met.

Professional Certification – refers to verification of proficiency relative to all or part of the BOK for the profession as designated by the PDC for inclusion in a certification exam. The selected BOK includes all or part of specific modules and is documented in an exam description. Each of the modules, or combinations, is given a specific weighting in the design of the exam. After obtaining a passing score on the exam, the candidate is issued a certificate stating he/she has met the competency standard.

Curriculum – refers to the list of modules that are used to document the BOK (see Appendix A).

Bloom’s Taxonomy – refers to a classification of levels of cognitive leaning widely used in the field of education. The levels are knowledge, understanding, application, analysis, integration, and evaluation. The active verbs used in the articulation of learning objectives define the cognitive level. In training, the learning activities are matched to the cognitive level. In assessment, the form of the question is also matched to the cognitive level. The use of Bloom’s Taxonomy is described in detail in the *Body of Knowledge Model* document.

The PDC has prepared program documents that are available on NCWM website.

- The Curriculum Outline, which breaks the profession of weights and measures into component parts called modules.
- The Body of Knowledge Model, which explains how to create modules to document the learning objectives.
- The Modules developed thus far.
- The Certifications developed thus far.

Results of the Retail Motor Fuel Dispensing Systems exam indicate it will be very important as the program moves forward that trainers integrate the learning objectives into their materials and design courses in such a way that candidates will achieve the desired levels of learning. *See Item 401-2 Instructor Improvement.*

2011 NCWM Interim Meeting: The Committee addressed the need to build partnerships between the states, National Institute of Standards and Technology (NIST), Office of Weights and Measures (OWM), and NCWM. Each group has roles in relation to the Certification Triangle as shown in the diagram below.

Professional Certification Program

Applying Certification Triangle (Triumvirate Partnership)

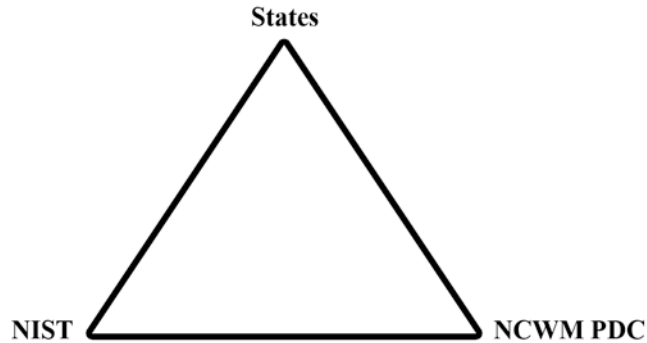

- States**
- National Certified Workforce
 - Assessment Tools and Certification Triangle Applied
 - Student Meets Training Milestones
 - Feedback to Trainer and Employee
 - Value Exam Results = Recognition + Adult Learning
 - Develop New Training Standards
 - NCWM/NIST Regional Education and Training

- NCWM PDC**
- Website and Administer Professional Certification Program
 - Enlist SMEs
 - Learning Objectives and Standards
 - Curriculum Work Plans, Discipline, Segments
 - Write/Verify Exam Questions
 - Exam Evaluation/Statistical Analysis

- NIST**
- Training and Education
 - Instructor Improvement “ADDIE”
 - State Instruction Support
 - Technical Materials
 - Train the Trainer Material
 - Classroom and Field Training

2012 NCWM Interim Meeting: The Committee received a comment from NIST, OWM that there is a need to provide an assessment tool to measure basic competence in fundamental subject areas such as NIST Handbook 44. They hope to partner with NCWM to administer those assessments using NCWM testing service. This would assure that participants at NIST, OWM sponsored training possess basic levels of proficiency in prerequisite materials so that instructors can deliver the primary material rather than spend time bringing all students up to the prerequisite level.

The Committee agrees and believes this fits with ongoing efforts to create a BOK and an exam to assess competence in mathematics for the entry level inspector. This could also be a useful tool to any jurisdiction offering training in these basic areas. The Committee will call these baseline competency examinations defined as:

Baseline Competency Examination - refers to verification of proficiency relative to one of the basic modules in the BOK for the profession. After obtaining a passing score on the exam, the candidate is issued a certificate stating he/she has met the competency standard.

The initial modules under consideration for the basic competency examinations are:

- Module XX. Weights and Measures Core Mathematics
- Module 4.2. NIST Handbook 44 – Introduction to Device Control
- Module 4.3. Weighing Systems – General
- Module 4.4. Dynamic Volume Measuring Systems – General

The BOK document for the Core Mathematics module has been drafted and will be posted on the website and appears in Appendix B.

The professional certifications currently developed (or in development) are:

- Retail Motor Fuel Dispensing Systems (Available)
- Package Checking Basic (Available)
- Small Capacity Weighing Systems Class III (Available) and
- Vehicle Tank Meters (In Development)

The Committee reported that 18 Subject Matter Expert (SME) volunteers are working on the basic package checking exam and 20 SME volunteers are working on the small capacity scale exam. Those exams are nearing completion. Invitations will be sent shortly to NCWM members to solicit SME volunteers to work on the vehicle tank meter exam. The Committee noted that SME's are the backbone of the program but also that they have competing priorities. One consideration is the idea of doing this work using web meetings, one to brief and train SMEs at the start of a project and one at the end to resolve any remaining issues with complex questions on the exam. The idea is to minimize the time commitment of our SME volunteers while maintaining high quality in our exams.

The PDC conducted a survey in November 2011 to evaluate priorities for future exam development, appropriate range of device capacities to include in the medium or large capacity scale modules, request feedback from people who had taken the Retail Motor Fuel Dispensing Systems Exam, appropriateness of our examinations for Registered Service Agents (RSAs), and potential problems in standardizing exams on the current NCWM standards.

The Committee received 134 responses covering 25 states, approximately 80 % weights and measures and 20 % industry. Based on the responses the Committee has selected the following subjects for priority development and will be requesting that the Board of Directors extend the Certification Coordinator's contract for these new projects:

- Medium Capacity Scales
- Large Capacity Scales III and IIII
- Liquefied Petroleum Gas (LPG) and Anhydrous Ammonia Liquid
- Price Verification

Survey questions on the Retail Motor Fuel Dispensing Systems Exam indicated that the majority were somewhat or very satisfied with the test taking experience, that the exam questions were appropriate to the basic level inspector, that the questions were straight forward and clearly written, and that they were able to finish in the allotted time. The only problems identified seemed to be related to computer connections and loading of graphics. NCWM staff worked with the testing service to mitigate these issues.

On the issue of using NCWM professional certifications for RSAs, the majority responded with interest in this area. The Committee worked with NCWM staff to solicit RSA volunteers to take the exam for free in order to obtain feedback. Volunteers who passed the exam would receive the formal certificate if they were members or if they pay the \$75 testing fee as non-members. Four RSAs took the exam thus far and others are scheduled to take it. The Committee will gather additional data, evaluate the results and report at the Annual Meeting.

2012 NCWM Interim Meeting: Several state officials questioned the appropriateness of charging these volunteers for the certificate if they are non-members. They noted that the service agents invested considerable time in taking the exam so that those who passed could have been rewarded with a waiver of the fee. Mr. Onwiler, NCWM Executive Director, reported that the exam fee structure is controlled by the Board of Directors. The exam fee is waived for members as a way to improve membership value. The exam has always been available to service agents,

but this was a means of acquiring volunteers for data collection without making them pay fees as non-members. The Committee verified that participants were advised of the conditions when the volunteers were contacted. The Western Weights and Measures Association (WWMA) made a proposal in 2011 that NCWM consider a tiered membership that would allow for a group rate category or reduced fees for non-members presently employed in a weights and measures related field wishing only to take the examinations. The Committee will ask the Board of Directors to consider these comments.

On the subject of the use of the current NCWM standard as the basis of all exams, the feedback from the survey clearly indicated that this should not be a problem for most jurisdictions. Therefore, the Committee will develop all exams based on the current editions of NCWM standards.

Officials had concerns about preparing their workforce for taking the Retail Motor Fuel Dispensing Systems Exam. As the PDC proceeds in offering other certifications, the Committee wants jurisdictions and industry to feel supported and confident that the training they provide for their workforce will be comprehensive and will prepare their people to take the certification exams without providing them with the exam questions. The Committee therefore recommends better communication so they understand what tools are available to help them create their own comprehensive training programs. The critical viewpoint is that a professional has to be prepared to perform the job and not just prepared to take the exam. This is the age old question of training to the learning objectives (the BOK) or training to the exam. The Committee strongly believes that training has to focus on the BOK and not on the exam questions.

2012 NCWM Annual Meeting: The Committee met with the Board of Directors to provide an update on progress and agree on priorities. The Certification Coordinator reported that two additional question banks for small capacity scales and package checking had passed the technical review and were submitted to NCWM Headquarters. He also reported that SME volunteers are now working on the vehicle tank meter exam, and that he is expecting to start the search for SME volunteers for the medium and large capacity scale exams shortly after the Annual Meeting. NCWM Executive Director Don Onwiler reported that there has been a slight glitch in the system that must be corrected before two new the exams can be opened for use. This involves making sure that Headquarters controls the individual's access to exams. Each candidate gets access to initially take the exam and then can get a retest if they fail. The original process had given the candidate access to all exams using the same credentials. As soon as this is corrected they will broadcast the availability of the two new exams.

The idea of accrediting the certification program was discussed. The Executive Director reported that he had been discussing the idea with the Institute for Credentialing Excellence (ICE) to see what parts of our program might be potential stumbling blocks. One area involves the SME's who develop and vet the test questions. Our problem is that our SMEs are virtually all trainers within their jurisdictions and the vetting and training functions need to be separated. One possible avenue that we are pursuing is to restrict the access each SME has to the exam bank by only allowing them to review a part (~1/4) of the test bank. The advice also suggested that SMEs be asked to sign over rights to the test questions and that NCWM seek to copyright its exams. The Committee and the Coordinator will continue to work with the Executive Director toward the goal of meeting the accreditation standards and both the Coordinator and Headquarters will work on documenting procedures as a necessary step in that process. The Executive Director will continue to seek advice towards this long term project from ICE.

The Executive Director provided the Committee and the Board of Directors with following statistics on the Retail Motor Fuel Exam.

	FY 2011	FY 2012
Number of Individuals taking the exam	76	128
Number of Organizations taking the exam	32	68
Number of Exams taken	189 Note(1)	Note (2)
Number of Certificates issued	45	79
Further Breakout		
State Gov't		86
Local Gov't		37
Industry		5

Note 1: In the Beta testing phase several took the exam multiple times.

Note 2: Results unavailable yet for FY 12

The Committee and the Board of Directors agreed that priorities will remain on the Professional Certifications. The Committee will not be pursuing the competency exams. This will help focus efforts to get the exams out based on priorities established by the survey the Committee conducted.

The Committee understands that the SMEs are the critical part of our certification program. The Committee wants to recognize those that are contributing and also encourage others to volunteer on future projects (i.e., the medium and large capacity scale exams that will start soon). To this end, the Committee wants to express gratitude by giving recognition to the following who contributed to the package checking and small capacity scale exams.

Package Checking Basic

D'Arcy, Carlos, FL
Wilson, Peter, VA
Gurney, Brett, UT
Chesser, Tim, AR
Merritt, Kevin, ID
Shultz, Steve, NV
McGee, Robert, SC
Hicks, Tyler, OK
Johnson, Ray, NM
Paquette, Marc, VT
Tubacki, Jeff, IL
Dillibaugh, John, PA
Miller, Rachelle, WI
Feagan, Bruce, WA
Butcher, Ken, NIST OWM

Small Capacity Scales Class III

Smith, Dan, AK
D'Arcy, Carlos, FL
Wilson, Peter, VA
Gurney, Brett, UT
Chesser, Tim, AR
Merritt, Kevin, ID
Shultz, Steve, NV
Stokes, John, SC
McGee, Robert, SC
Hicks, Tyler, OK
Johnson, Ray, NM
Paquette, Marc, VT
Tubacki, Jeff, IL
Dillibaugh, John, PA
Miller, Rachelle, WI
Feagan, Bruce, WA

The Committee heard testimony from a number of individuals during the open hearings and appreciates the comments. In particular, the Committee is very pleased that states are starting to find ways to integrate our standards and the certifications in their programs. One state reported their efforts to mandate in regulation that RSAs get NCWM certification to demonstrate competence. Another is giving CEUs to county officials who obtain NCWM Certification. Others are using the exam results to evaluate their training efforts. One jurisdiction is using NCWM certifications in labor relations to demonstrate that retention and promotion decisions are being based on an

unbiased third party assessment. The CWMA is considering whether it might be possible to use the NCWM exam in their reciprocal testing program for RSAs.

One state director reported that he had his entire staff take the RMFD exam. He provided some valuable feedback that the Committee and the Coordinator will consider. One involved making clear which version of the handbooks is being used in the exams. He also reported that candidates taking the exam wanted to learn about which questions they got wrong. He also wanted the Committee to look at extending the Certification Program to accredit the overall weights and measures program.

The Committee understands the concern about the wrong answers, but maintaining integrity of the test precludes us from giving that kind of specific feedback on the exam. At the end of the exam, the candidate is provided with the pass/fail on each segment of the exam and the final score. The candidate is also provided with the option of designating the e-mail address where the results will be sent. Thus, the results could go to a Supervisor or the Director. The Committee is considering avenues to provide feedback that will help states identify potential weaknesses in their training programs. Again, the Committee wants to divert the focus from the test back to ensuring mastery of the learning objectives in the BOK. To that end, the Committee is considering providing general statistics on each part of the exam so that a jurisdiction/company could compare their staff's results with the composite of all those who took the exam. There is a further fear that providing detailed feedback on specific learning objectives where exam results showed low scoring would then divert the focus from the broad objectives of the BOK.

2012 CWMA Interim Meeting: There was general support for removing much of the content in this item and making it reference material on the NCWM website. There was a question regarding how NCWM assesses exam difficulty and a suggestion to look at professional certification programs for other industries to see what the passing rates are and what they use to know if the exams are at the appropriate difficulty level. There were several suggestions to improve the exam process, including a flag button on each test question that test takers could select to notify that a specific question was problematic. Another was to provide a direct link at the end of the test to a survey site or other site for immediate feedback on the test. Another suggestion was to disclose to test takers which areas of NIST Handbook 44 they should study based on their results, without being told the actual questions that were incorrect. This would maintain the integrity of the test while providing guidance to the test taker.

2012 WWMA Annual Meeting: The WWMA PDC chair presented a PowerPoint presentation reviewing the Professional Certification Program (PCP) entitled "Using the NCWM Program" during the open hearings. One comment/question was received during the open hearings regarding the time limit to take an exam after an individual has registered and received their passcode. The Committee, in conversation with the NCWM Executive Director by telephone, confirmed that there is no time limit for initial log in or between taking the first and second exam. Furthermore, if a NCWM member fails the second exam, he or she can reapply and retest until they pass the exam, free of charge. The Committee discussed the draft FAQ sheet developed by Ross Andersen and recognized that it is a good start and is in need of further development. The Committee is willing to assist with enhancing and clarifying this document. The Committee discussed the exam result data compiled on the three exams to date. The RMFD exam has been available since 2010. The Package Checking Basic and Small Capacity Scales Class III have been available since August 2012. The Committee recognized the likelihood that the pass/fail rate on the exams to date may not reflect the difficulty of the exam since many may be taking the exams to familiarize themselves with the exam process, not necessarily for obtaining the certificate. The Committee discussed accreditation of the PCP, the benefits to both industry and regulatory individuals, and the issue created by crossover between persons serving as both Subject Matter Experts (SMEs) and trainers. The Committee discussed the difference between certification to demonstrate basic competency, accreditation, and licensing with continuing education requirements. The Committee believes that for the PCP to be accredited more information is needed about the specific accreditation requirements so the NCWM Professional Development Committee (NCWM PDC) can efficiently and correctly design the Program. The Committee encouraged the WWMA audience to take one or more of the three exams that are available. The Committee discussed the need for volunteer SMEs, exam results data and feedback on the exam taking experience, to assist the NCWM PDC in the continuous improvement of existing exams, and further development of future exams. Feedback can be submitted to the NCWM PDC through NCWM via e-mail to info@ncwm.net or call (402) 434-4880. The concept of free exams or a "rollback" in pricing for a period of time was discussed. There may be jurisdictions, business organizations, or other entities that desire to take the exams, but

find the cost of membership is prohibitive. The Committee believed there might need to be an initial incentive to encourage participation. The Committee recommends the following:

- NCWM survey jurisdictions to find out the number of Registered Service Agents (RSAs) within the jurisdiction, whether these jurisdictions require the RSA to pass an examination, and what fees and timelines are associated with these requirements. Determining the number of jurisdictions that require licensing and the content of their examinations (e.g., regulatory vs. technical requirements) would allow the NCWM PDC to evaluate the appropriateness of administering the same exams for RSAs or development of separate exams particular to RSAs. The jurisdictions using these written exams in their training programs could do so in conjunction with a field component to certify inspectors and RSAs.
- NCWM Executive Director continue research into the accreditation requirements and recommend the appropriate accreditation body for the PCP; weights and measures jurisdictions and industry organizations that may require certification recognize the value and credibility provided through formal accreditation.
- NCWM PDC continues its work refining the PCP FAQ Sheet. The WWMA PDC Committee is willing to assist with enhancing and clarifying this document. The PCP FAQ Sheet is a valuable tool for new exam takers.
- NCWM PDC consider implementing a policy of offering newly introduced exams at a reduced price for a fixed period of time (e.g., \$30 per exam for six months, providing the exam taker agree to provide feedback on the exam contents and exam taking experience before receiving their certificate). NCWM needs to encourage the widest possible participation in the early stages of PCP development. To bring the PCP to full program fruition, offering incentives to exam takers may assist the NCWM in reaching its goals.

One jurisdiction indicated that they would begin using the examinations as part of their annual performance plans and performance evaluations for their staff. The Committee realized that the PCP was originally designed for weights and measures officials, but discussed whether the exams should be modified for RSA to put more emphasis on proper calibrations, sealing, etc.

THIS PAGE INTENTIONALLY LEFT BLANK

Appendix C

History of Instructor Improvement

Source:

Carryover Item 401-3 (This item originated from the Committee and first appeared on its agenda in 2003.)

Background/Discussion:

Prior to the 2010 Annual Meeting, Ms. Georgia Harris, NIST, OWM provided the Committee with reference material on teaching methods and assessment of training success. Distilling the essence of these materials, the Committee believes that instructors need training in more than just the technical material; they need training in setting the learning objectives, developing the training materials with those objectives in mind, selecting training methods that incorporate adult learning styles, and evaluating the effectiveness of their training.

Education Subsystem

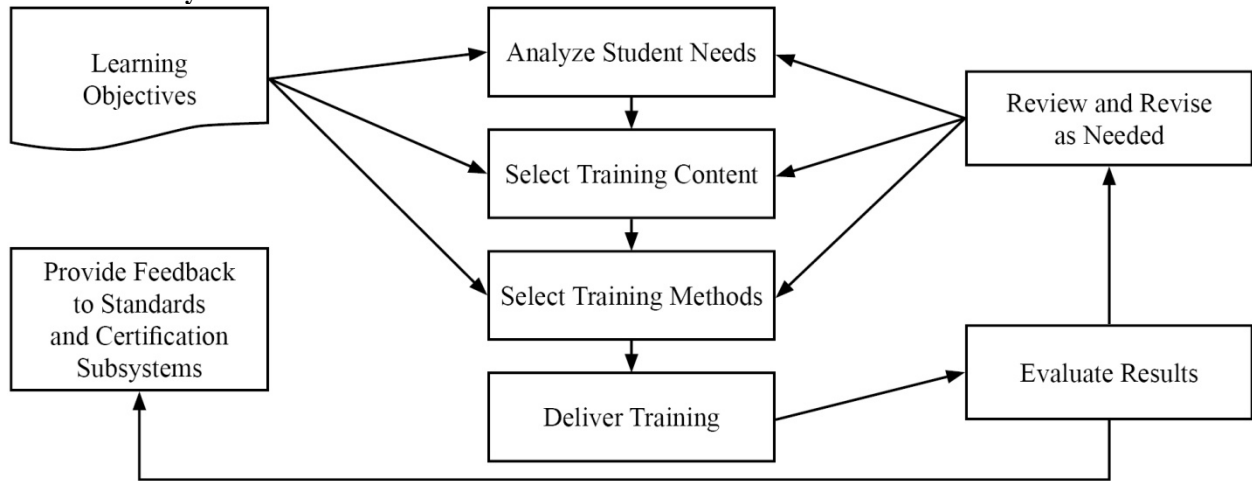

The chart below covers three levels of learning objectives and relates them to (1) the training activities most likely to be successful and (2) the best methods for assessing the success of the training. The curriculum segments state the learning objectives using verbs similar to those in the bottom row of the table. These drive both the training activities required to promote adult learning and the assessment tools appropriate to measure success at that level.

Assessments	Multiple Choice	Multiple Choice	Practical Examples Short Answer
Training Activities	Lecture Videos Examples	Discussion Review Learner Presentation	Exercises Simulations Demonstrations
Cognitive Levels	Knowledge	Comprehensive	Application
	Define Relate List	Restate Discuss Describe Identify	Employ Apply Use Illustrate

NIST, OWM has expressed strong interest in collaborating with NCWM in efforts to educate instructors in adult learning techniques and relating them to the learning objectives in NCWM curriculum. The Committee will be posting NIST, OWM material on converting technical content to training material on the PDC training resources

webpages. The importance of pre-training analysis and post-training evaluation cannot be overestimated. Failure to include these steps often leads to failure of training efforts.

Professional Certification Program
Systems Approach to Training Evaluation

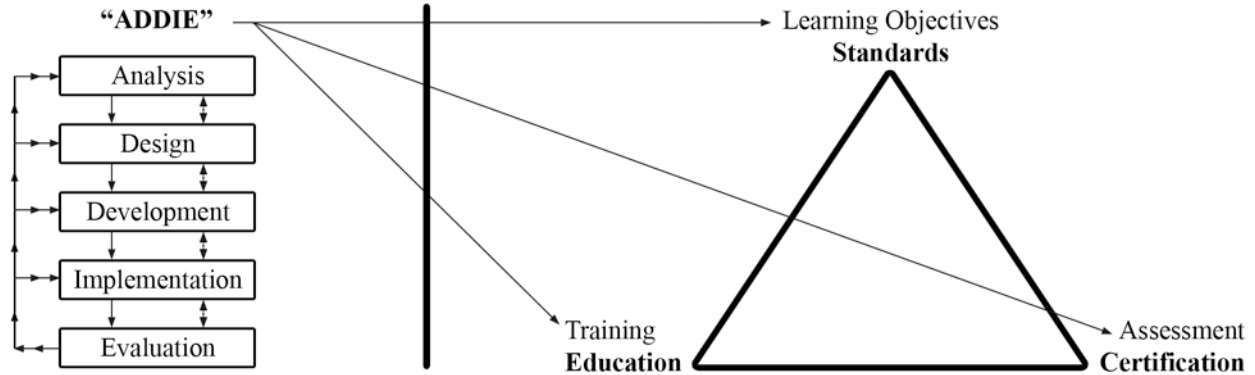

The Committee is calling on the states and other training developers to implement the Analysis, Design, Development, Implementation, and Evaluation (ADDIE) model in their training preparations and post training evaluation. Everyone needs to participate in the development of new BOK modules and then encourage their trainers to use existing BOK modules in their training plans.

The Committee encourages members to also look at the presentation on *A Complete Training Program* prepared by Ms. Carol, Hockert, NIST, OWM. The presentation outlines ways to develop training programs and improve instruction of weights and measures material. Contact Ms. Hockert for a copy.

2012 NCWM Interim Meeting: Advisors from NIST, OWM, reported that they are using NCWM BOK in preparing new training initiatives. They are stressing adult learning techniques, particularly focusing on the use of hands-on training as the most popular and effective training tool. This ties in closely with the new baseline competency exams discussed in Item 410-1. NIST, OWM is using these exams to ensure students in NIST sponsored training courses are competent in prerequisite course materials prior to taking training. They reported that they are already drafting questions for the baseline competency exams. They see significant efficiencies in using NCWM testing services for this purpose since they are already in place.

Ms. Hockert, NIST, OWM, recommended a basic math prerequisite for persons taking Metrology or other related weights and measures courses sponsored by NIST. The math exam would allow trainees to demonstrate entry level math skills and make the training process more efficient and effective. One official discussed the California licensing requirement of a college degree which requires a certain number of math courses and asked if this would satisfy the need for the math prerequisite. Several California officials expressed concern about the Professional Certification Program replacing existing state licensing programs, and if adopted, it might require amendment of existing state statutes. Because math competency is an essential skill for weights and measures work, the Committee recommends that the PDC include in its scope the development of an exam to demonstrate basic math competency before taking the Fundamentals of Metrology or other training courses at NIST.

2011 SWMA Annual Meeting: It was stated that we should consider training state trainers on adult learning techniques as well as subject matter. No further recommendations were made.

2012 NCWM Annual Meeting: The Committee stressed instructor improvement. The Committee reviewed the importance of using the NCWM learning objectives and the ADDIE model in training. This stresses the importance of training to the goals in the BOK and not training to pass the test. If the training is appropriate and has been delivered effectively, the employee should have no problem passing a fair exam. The end is not a certificate on the wall, but rather a competent inspector. In other words,

JOB SUCCESS = EXAM SUCCESS

Ms. Hockert stressed that good training requires a partnership between the trainee, trainer, and the supervisor. The Committee agrees that buy-in from all levels is critical to training success.

2012 CWMA Interim Meeting: The Committee recommended archiving most of the content in this item to the NCWM website as reference material.

2012 WWMA Annual Meeting: The Committee noted that it is in the best interest of NIST and NCWM that regional training efforts are of the highest quality and uniform throughout the United States. The Committee recommends the following:

- Regional trainers be selected as per the process agreed upon between NIST and NCWM;
- Regional trainers receive courses on adult learning techniques and converting technical information into training materials;
- Regional trainers be afforded the opportunity to shadow NIST trainers as they perform training in individual jurisdictions; and
- The use of funds from the Associate Membership Committee or the NIST Training Initiative Grant be made available for this purpose.

2012 NEWMA Interim Meeting: Members expressed interest in NIST Train-the-Trainer classes. A demonstration was provided on how to access materials for taking the Professional Certification Exams and then for taking the exams. The Committee encouraged those in attendance to seek certification of their inspectors.

THIS PAGE INTENTIONALLY LEFT BLANK

Appendix A

Professional Certification Program Curriculum Work Plan

Revised January 2010

Segment/Subject

Level 1/Level 2/Level 3

1. Fundamentals of Weights and Measures

- 1.1. Introduction to Weights and Measures Programs
- 1.2. Weights and Measures Laws and Regulations
- 1.3. Field Standards and Test Equipment
- 1.4. State Program Scope and Overview
- 1.5. Enforcement Powers

2. Weights and Measures Administration

- 2.1. Fundamentals of Weights and Measures Administration (Commercial System, Powers and Duties, etc.)
- 2.2. Administration Functions (Personnel, Management, Budget, Safety, etc.)
- 2.3. Legislation and Regulations (Legal Considerations, Interaction with Legislature, Stakeholders, Industry, etc.)
- 2.4. Regulatory Control (Device Inspection, Commodities, Complaints)
- 2.5. Laboratory Metrology Administration (Purpose of Laboratory, Responsibilities of Metrologist, NIST Expectations for Recognition of Laboratory, Quality System, Training Requirements, etc.)
- 2.6. Public Relations and Communications (Publicity, Public Relations, Communications)

3. Laboratory Metrology

- 3.1. NIST Basic Metrology
- 3.2. NIST Intermediate Metrology
- 3.3. NIST Advanced Metrology

4. Device Control Program

- 4.1. Safety Considerations
- 4.2. NIST Handbook 44 – Introduction to Device Control
- 4.3. Weighing Systems, General
 - 4.3.1. Static Electronic Weighing Systems, General
 - 4.3.2. Static Mechanical and Hybrid Weighing Systems, General
 - 4.3.3. Dynamic Weighing Systems, General
 - 4.3.4. Precision Weighing Systems Class I and II
 - 4.3.5. Small Capacity Weighing Systems Class III
 - 4.3.6. Medium Capacity Weighing Systems Class III
 - 4.3.7. Large Capacity Class III and III L Weighing Systems (Vehicle and Livestock)
 - 4.3.8. Large Capacity Class III and III L Weighing Systems - Advanced
 - 4.3.9. Railroad Track Weighing Systems
 - 4.3.10. In-Motion Railroad Track Weighing Systems
 - 4.3.11. Hopper Weighing Systems
 - 4.3.12. Automatic Bulk Weighing Systems
 - 4.3.13. Automatic Weighing Systems
 - 4.3.14. Belt Conveyor Weighing Systems
 - 4.3.15. In-Motion Monorail Weighing Systems
 - 4.3.16. Point-of-Sale Weighing Systems
 - 4.3.17. Other Specialty Weighing Systems
- 4.4. Dynamic Measuring Systems – General
 - 4.4.1. Retail Motor Fuel Dispensers

- 4.4.2. Loading Rack and Other Stationary Metering Systems
- 4.4.3. Loading Rack and Other Stationary Metering Systems – Advanced
- 4.4.4. Vehicle-Tank Meter Systems
- 4.4.5. Vehicle-Tank Meter Systems – Advanced
- 4.4.6. Milk Metering Systems
- 4.4.7. Water Meters
- 4.4.8. Liquefied Petroleum Gas (LPG) / Anhydrous Ammonia Liquid Metering Systems
- 4.4.9. LPG/Anhydrous Ammonia Liquid Metering Systems – Advanced
- 4.4.10. LPG Vapor Meter Systems
- 4.4.11. Mass Flow Metering Systems
- 4.4.12. Other Metering Systems (Cryogenics, Carbon Dioxide, etc.)
- 4.5. Static Volume Measuring Systems – General
 - 4.5.1. Liquid Measures
 - 4.5.2. Farm Milk Tanks
 - 4.5.3. Dry Measures
- 4.6. Other Measuring Systems
 - 4.6.1. Taximeters and Odometers
 - 4.6.2. Wire and Cordage Measuring Systems
 - 4.6.3. Linear Measures
 - 4.6.4. Timing Devices
 - 4.6.5. Weights
 - 4.6.6. Multiple Dimension Measuring Systems
- 4.7. Quality Measuring Systems
 - 4.7.1. Grain Moisture Meters
 - 4.7.2. NIR Grain Analyzers
 - 4.7.3. Carcass Evaluation Systems
- 5. Market Practices, Laws and Regulations (NIST Handbook 130) and Commodities (NIST Handbook 133)**
 - 5.1. Safety Considerations – Market Practices, NIST Handbook 130, NIST Handbook 133
 - 5.2. NIST Handbook 130 – Laws and Regulations
 - 5.2.1. NIST Handbook 130 – General Provisions
 - 5.2.2. Packaging and Labeling Regulations
 - 5.2.3. Method of Sale Regulations
 - 5.2.4. Quality of Automotive Fuels and Lubricants
 - 5.2.5. Price Verification
 - 5.3. NIST Handbook 133 – Package Net Contents Control
 - 5.3.1. Commodities – General
 - 5.3.2. Packages Labeled by Weight, Standard and Random
 - 5.3.3. Packages Labeled by Weight, Special Commodities
 - 5.3.4. Packages Labeled by Volume (Volumetric and Gravimetric Testing)
 - 5.3.5. Packages Labeled by Volume, Special
 - 5.3.6. Packages Labeled by Length/Area/Thickness
 - 5.3.7. Packages Labeled by Count
 - 5.3.8. Other Package Types
 - 5.4. Test Purchases
 - 5.5. E-Commerce

Note: Initial Verification has been intentionally been left off this listing and will be addressed later.

Appendix B

History of Professional Certification Program

Source:

Carryover Item 401-1 (This item originated from the Committee and first appeared on its Agenda in 2003 and has undergone continuing development.) The numbering change reflects harmonization in all NCWM reports. Copies of reports from recent years are also available on the website under Interim and Annual Meeting archives pages.

Background/Discussion:

It is important that users of the Professional Certification Program understand how the pieces fit together and form a coherent system. To illustrate the relationships the Committee can describe the system as a triangle of interdependent parts (see diagram below). The standards come in the form of goals with measureable learning objectives. The education part involves training provided to help the candidate reach the desired level of proficiency for each of the learning objectives. The certification involves an assessment of proficiency that measures whether or not the objectives have been met.

Certification Triangle

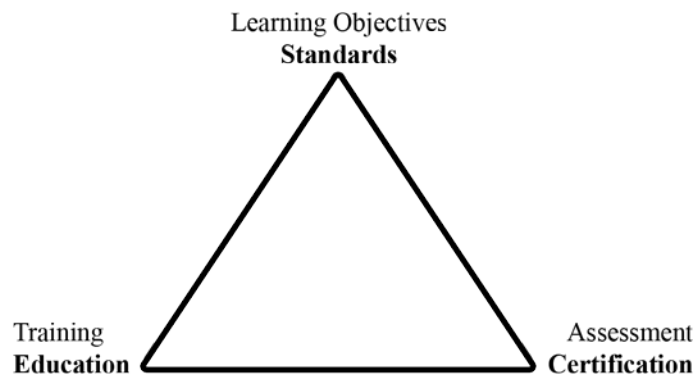

The Committee has until now focused attention on the standards and the certification pieces in the triangle as illustrated in the following flowcharts.

Standard Subsystem

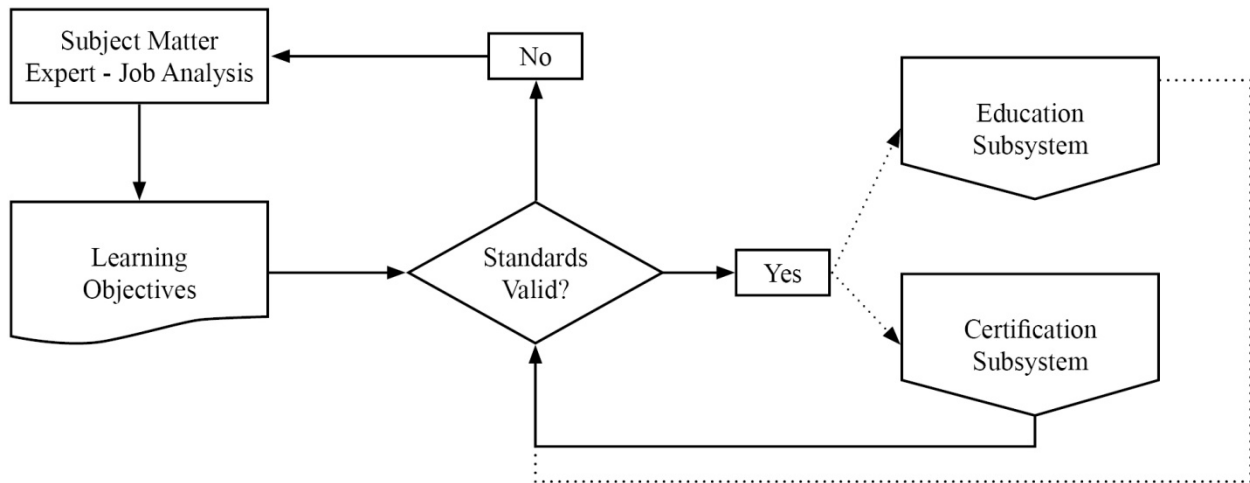

Certification Subsystem

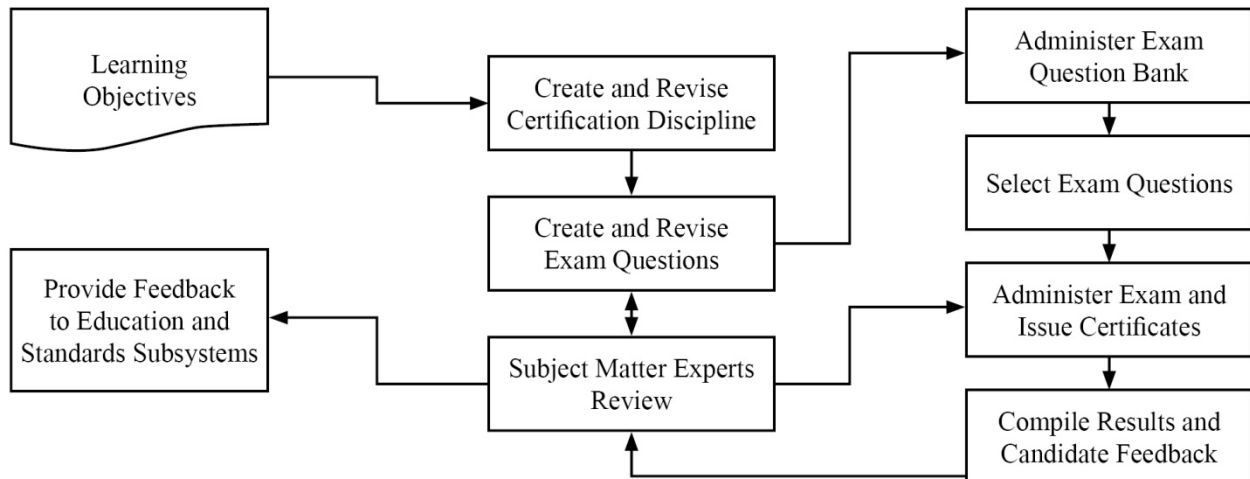

The Committee has described this work in a number of documents. In those documents the Committee is using terminology consistent with current usage in the education and certification field. The following important terms will be used throughout the Committee’s work on the subject.

Body of Knowledge (BOK) – refers broadly to the knowledge and skills required to function as a weights and measures professional. The term may refer broadly to the entire scope of knowledge and skills required within the profession or in a more directed manner to any selected subset for which the particular person is responsible. The BOK describes what you expect the weights and measures professional to achieve as opposed to how he/she will achieve it. To make the BOK more manageable in administration of the Professional Certification Program, it will be subdivided into modules in a tree-like structure moving from general knowledge and skills to more specific.

Module – refers to a group of related subject materials within the BOK. The module contains the articulated learning objectives for the subject area. Each module is considered a single, self-contained course of study. However, a broader course may span multiple modules and specific training may include only part of a module or parts of multiple modules. The PDC has created a standard format to create modules for the Professional Certification Program. The Committee has also created the Curriculum Outline and work plans to help manage the work activities within the program to create the many modules necessary to cover the entire profession.

Learning Objective – refers to the articulation of expectations of performance in measureable terms. Learning objectives are stated using active terms to be precise and measureable. There are two types of learning objectives, a terminal objective and an enabling objective. Terminal objectives state broadly the expectation of performance. The enabling objectives state the specific parts or steps required to demonstrate competence. The PDC has developed a guide to writing the learning objectives for both terminal and enabling which include the active verbs associated with the cognitive levels in Bloom’s Taxonomy. In training, the instructor will typically choose learning activities to explore each of the enabling objectives in an attempt to reach the terminal objective. In assessment, the questions will typically test for competence in each of the enabling objectives to demonstrate that the terminal objectives have been met.

Professional Certification – refers to verification of proficiency relative to all or part of the BOK for the profession as designated by the PDC for inclusion in a certification exam. The selected BOK includes all or part of specific modules and is documented in an exam description. Each of the modules, or combinations, is given a specific weighting in the design of the exam. After obtaining a passing score on the exam, the candidate is issued a certificate stating he/she has met the competency standard.

Curriculum – refers to the list of modules that are used to document the BOK (see Appendix A).

Bloom’s Taxonomy – refers to a classification of levels of cognitive leaning widely used in the field of education. The levels are knowledge, understanding, application, analysis, integration, and evaluation. The active verbs used in the articulation of learning objectives define the cognitive level. In training, the learning activities are matched to the cognitive level. In assessment, the form of the question is also matched to the cognitive level. The use of Bloom’s Taxonomy is described in detail in the *Body of Knowledge Model* document.

The PDC has prepared program documents that are available on NCWM website.

- The Curriculum Outline, which breaks the profession of weights and measures into component parts called modules.
- The Body of Knowledge Model, which explains how to create modules to document the learning objectives.
- The Modules developed thus far.
- The Certifications developed thus far.

Results of the Retail Motor Fuel Dispensing Systems exam indicate it will be very important as the program moves forward that trainers integrate the learning objectives into their materials and design courses in such a way that candidates will achieve the desired levels of learning. *See Item 401-2 Instructor Improvement.*

2011 NCWM Interim Meeting: The Committee addressed the need to build partnerships between the states, National Institute of Standards and Technology (NIST), Office of Weights and Measures (OWM), and NCWM. Each group has roles in relation to the Certification Triangle as shown in the diagram below.

Professional Certification Program

Applying Certification Triangle (Triumvirate Partnership)

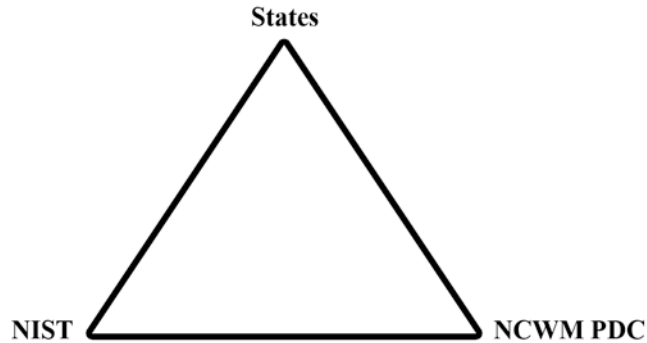

- States**
- National Certified Workforce
 - Assessment Tools and Certification Triangle Applied
 - Student Meets Training Milestones
 - Feedback to Trainer and Employee
 - Value Exam Results = Recognition + Adult Learning
 - Develop New Training Standards
 - NCWM/NIST Regional Education and Training

- NCWM PDC**
- Website and Administer Professional Certification Program
 - Enlist SMEs
 - Learning Objectives and Standards
 - Curriculum Work Plans, Discipline, Segments
 - Write/Verify Exam Questions
 - Exam Evaluation/Statistical Analysis

- NIST**
- Training and Education
 - Instructor Improvement “ADDIE”
 - State Instruction Support
 - Technical Materials
 - Train the Trainer Material
 - Classroom and Field Training

2012 NCWM Interim Meeting: The Committee received a comment from NIST, OWM that there is a need to provide an assessment tool to measure basic competence in fundamental subject areas such as NIST Handbook 44. They hope to partner with NCWM to administer those assessments using NCWM testing service. This would assure that participants at NIST, OWM sponsored training possess basic levels of proficiency in prerequisite materials so that instructors can deliver the primary material rather than spend time bringing all students up to the prerequisite level.

The Committee agrees and believes this fits with ongoing efforts to create a BOK and an exam to assess competence in mathematics for the entry level inspector. This could also be a useful tool to any jurisdiction offering training in these basic areas. The Committee will call these baseline competency examinations defined as:

Baseline Competency Examination - refers to verification of proficiency relative to one of the basic modules in the BOK for the profession. After obtaining a passing score on the exam, the candidate is issued a certificate stating he/she has met the competency standard.

The initial modules under consideration for the basic competency examinations are:

- Module XX. Weights and Measures Core Mathematics
- Module 4.2. NIST Handbook 44 – Introduction to Device Control
- Module 4.3. Weighing Systems – General
- Module 4.4. Dynamic Volume Measuring Systems – General

The BOK document for the Core Mathematics module has been drafted and will be posted on the website and appears in Appendix B.

The professional certifications currently developed (or in development) are:

- Retail Motor Fuel Dispensing Systems (Available)
- Package Checking Basic (Available)
- Small Capacity Weighing Systems Class III (Available) and
- Vehicle Tank Meters (In Development)

The Committee reported that 18 Subject Matter Expert (SME) volunteers are working on the basic package checking exam and 20 SME volunteers are working on the small capacity scale exam. Those exams are nearing completion. Invitations will be sent shortly to NCWM members to solicit SME volunteers to work on the vehicle tank meter exam. The Committee noted that SME's are the backbone of the program but also that they have competing priorities. One consideration is the idea of doing this work using web meetings, one to brief and train SMEs at the start of a project and one at the end to resolve any remaining issues with complex questions on the exam. The idea is to minimize the time commitment of our SME volunteers while maintaining high quality in our exams.

The PDC conducted a survey in November 2011 to evaluate priorities for future exam development, appropriate range of device capacities to include in the medium or large capacity scale modules, request feedback from people who had taken the Retail Motor Fuel Dispensing Systems Exam, appropriateness of our examinations for Registered Service Agents (RSAs), and potential problems in standardizing exams on the current NCWM standards.

The Committee received 134 responses covering 25 states, approximately 80 % weights and measures and 20 % industry. Based on the responses the Committee has selected the following subjects for priority development and will be requesting that the Board of Directors extend the Certification Coordinator's contract for these new projects:

- Medium Capacity Scales
- Large Capacity Scales III and IIII
- Liquefied Petroleum Gas (LPG) and Anhydrous Ammonia Liquid
- Price Verification

Survey questions on the Retail Motor Fuel Dispensing Systems Exam indicated that the majority were somewhat or very satisfied with the test taking experience, that the exam questions were appropriate to the basic level inspector, that the questions were straight forward and clearly written, and that they were able to finish in the allotted time. The only problems identified seemed to be related to computer connections and loading of graphics. NCWM staff worked with the testing service to mitigate these issues.

On the issue of using NCWM professional certifications for RSAs, the majority responded with interest in this area. The Committee worked with NCWM staff to solicit RSA volunteers to take the exam for free in order to obtain feedback. Volunteers who passed the exam would receive the formal certificate if they were members or if they pay the \$75 testing fee as non-members. Four RSAs took the exam thus far and others are scheduled to take it. The Committee will gather additional data, evaluate the results and report at the Annual Meeting.

2012 NCWM Interim Meeting: Several state officials questioned the appropriateness of charging these volunteers for the certificate if they are non-members. They noted that the service agents invested considerable time in taking the exam so that those who passed could have been rewarded with a waiver of the fee. Mr. Onwiler, NCWM Executive Director, reported that the exam fee structure is controlled by the Board of Directors. The exam fee is waived for members as a way to improve membership value. The exam has always been available to service agents,

but this was a means of acquiring volunteers for data collection without making them pay fees as non-members. The Committee verified that participants were advised of the conditions when the volunteers were contacted. The Western Weights and Measures Association (WWMA) made a proposal in 2011 that NCWM consider a tiered membership that would allow for a group rate category or reduced fees for non-members presently employed in a weights and measures related field wishing only to take the examinations. The Committee will ask the Board of Directors to consider these comments.

On the subject of the use of the current NCWM standard as the basis of all exams, the feedback from the survey clearly indicated that this should not be a problem for most jurisdictions. Therefore, the Committee will develop all exams based on the current editions of NCWM standards.

Officials had concerns about preparing their workforce for taking the Retail Motor Fuel Dispensing Systems Exam. As the PDC proceeds in offering other certifications, the Committee wants jurisdictions and industry to feel supported and confident that the training they provide for their workforce will be comprehensive and will prepare their people to take the certification exams without providing them with the exam questions. The Committee therefore recommends better communication so they understand what tools are available to help them create their own comprehensive training programs. The critical viewpoint is that a professional has to be prepared to perform the job and not just prepared to take the exam. This is the age old question of training to the learning objectives (the BOK) or training to the exam. The Committee strongly believes that training has to focus on the BOK and not on the exam questions.

2012 NCWM Annual Meeting: The Committee met with the Board of Directors to provide an update on progress and agree on priorities. The Certification Coordinator reported that two additional question banks for small capacity scales and package checking had passed the technical review and were submitted to NCWM Headquarters. He also reported that SME volunteers are now working on the vehicle tank meter exam, and that he is expecting to start the search for SME volunteers for the medium and large capacity scale exams shortly after the Annual Meeting. NCWM Executive Director Don Onwiler reported that there has been a slight glitch in the system that must be corrected before two new the exams can be opened for use. This involves making sure that Headquarters controls the individual's access to exams. Each candidate gets access to initially take the exam and then can get a retest if they fail. The original process had given the candidate access to all exams using the same credentials. As soon as this is corrected they will broadcast the availability of the two new exams.

The idea of accrediting the certification program was discussed. The Executive Director reported that he had been discussing the idea with the Institute for Credentialing Excellence (ICE) to see what parts of our program might be potential stumbling blocks. One area involves the SME's who develop and vet the test questions. Our problem is that our SMEs are virtually all trainers within their jurisdictions and the vetting and training functions need to be separated. One possible avenue that we are pursuing is to restrict the access each SME has to the exam bank by only allowing them to review a part (~1/4) of the test bank. The advice also suggested that SMEs be asked to sign over rights to the test questions and that NCWM seek to copyright its exams. The Committee and the Coordinator will continue to work with the Executive Director toward the goal of meeting the accreditation standards and both the Coordinator and Headquarters will work on documenting procedures as a necessary step in that process. The Executive Director will continue to seek advice towards this long term project from ICE.

The Executive Director provided the Committee and the Board of Directors with following statistics on the Retail Motor Fuel Exam.

	FY 2011	FY 2012
Number of Individuals taking the exam	76	128
Number of Organizations taking the exam	32	68
Number of Exams taken	189 Note(1)	Note (2)
Number of Certificates issued	45	79
Further Breakout		
State Gov't		86
Local Gov't		37
Industry		5

Note 1: In the Beta testing phase several took the exam multiple times.

Note 2: Results unavailable yet for FY 12

The Committee and the Board of Directors agreed that priorities will remain on the Professional Certifications. The Committee will not be pursuing the competency exams. This will help focus efforts to get the exams out based on priorities established by the survey the Committee conducted.

The Committee understands that the SMEs are the critical part of our certification program. The Committee wants to recognize those that are contributing and also encourage others to volunteer on future projects (i.e., the medium and large capacity scale exams that will start soon). To this end, the Committee wants to express gratitude by giving recognition to the following who contributed to the package checking and small capacity scale exams.

Package Checking Basic

D'Arcy, Carlos, FL
Wilson, Peter, VA
Gurney, Brett, UT
Chesser, Tim, AR
Merritt, Kevin, ID
Shultz, Steve, NV
McGee, Robert, SC
Hicks, Tyler, OK
Johnson, Ray, NM
Paquette, Marc, VT
Tubacki, Jeff, IL
Dillibaugh, John, PA
Miller, Rachelle, WI
Feagan, Bruce, WA
Butcher, Ken, NIST OWM

Small Capacity Scales Class III

Smith, Dan, AK
D'Arcy, Carlos, FL
Wilson, Peter, VA
Gurney, Brett, UT
Chesser, Tim, AR
Merritt, Kevin, ID
Shultz, Steve, NV
Stokes, John, SC
McGee, Robert, SC
Hicks, Tyler, OK
Johnson, Ray, NM
Paquette, Marc, VT
Tubacki, Jeff, IL
Dillibaugh, John, PA
Miller, Rachelle, WI
Feagan, Bruce, WA

The Committee heard testimony from a number of individuals during the open hearings and appreciates the comments. In particular, the Committee is very pleased that states are starting to find ways to integrate our standards and the certifications in their programs. One state reported their efforts to mandate in regulation that RSAs get NCWM certification to demonstrate competence. Another is giving CEUs to county officials who obtain NCWM Certification. Others are using the exam results to evaluate their training efforts. One jurisdiction is using NCWM certifications in labor relations to demonstrate that retention and promotion decisions are being based on an

unbiased third party assessment. The CWMA is considering whether it might be possible to use the NCWM exam in their reciprocal testing program for RSAs.

One state director reported that he had his entire staff take the RMFD exam. He provided some valuable feedback that the Committee and the Coordinator will consider. One involved making clear which version of the handbooks is being used in the exams. He also reported that candidates taking the exam wanted to learn about which questions they got wrong. He also wanted the Committee to look at extending the Certification Program to accredit the overall weights and measures program.

The Committee understands the concern about the wrong answers, but maintaining integrity of the test precludes us from giving that kind of specific feedback on the exam. At the end of the exam, the candidate is provided with the pass/fail on each segment of the exam and the final score. The candidate is also provided with the option of designating the e-mail address where the results will be sent. Thus, the results could go to a Supervisor or the Director. The Committee is considering avenues to provide feedback that will help states identify potential weaknesses in their training programs. Again, the Committee wants to divert the focus from the test back to ensuring mastery of the learning objectives in the BOK. To that end, the Committee is considering providing general statistics on each part of the exam so that a jurisdiction/company could compare their staff's results with the composite of all those who took the exam. There is a further fear that providing detailed feedback on specific learning objectives where exam results showed low scoring would then divert the focus from the broad objectives of the BOK.

2012 CWMA Interim Meeting: There was general support for removing much of the content in this item and making it reference material on the NCWM website. There was a question regarding how NCWM assesses exam difficulty and a suggestion to look at professional certification programs for other industries to see what the passing rates are and what they use to know if the exams are at the appropriate difficulty level. There were several suggestions to improve the exam process, including a flag button on each test question that test takers could select to notify that a specific question was problematic. Another was to provide a direct link at the end of the test to a survey site or other site for immediate feedback on the test. Another suggestion was to disclose to test takers which areas of NIST Handbook 44 they should study based on their results, without being told the actual questions that were incorrect. This would maintain the integrity of the test while providing guidance to the test taker.

2012 WWMA Annual Meeting: The WWMA PDC chair presented a PowerPoint presentation reviewing the Professional Certification Program (PCP) entitled "Using the NCWM Program" during the open hearings. One comment/question was received during the open hearings regarding the time limit to take an exam after an individual has registered and received their passcode. The Committee, in conversation with the NCWM Executive Director by telephone, confirmed that there is no time limit for initial log in or between taking the first and second exam. Furthermore, if a NCWM member fails the second exam, he or she can reapply and retest until they pass the exam, free of charge. The Committee discussed the draft FAQ sheet developed by Ross Andersen and recognized that it is a good start and is in need of further development. The Committee is willing to assist with enhancing and clarifying this document. The Committee discussed the exam result data compiled on the three exams to date. The RMFD exam has been available since 2010. The Package Checking Basic and Small Capacity Scales Class III have been available since August 2012. The Committee recognized the likelihood that the pass/fail rate on the exams to date may not reflect the difficulty of the exam since many may be taking the exams to familiarize themselves with the exam process, not necessarily for obtaining the certificate. The Committee discussed accreditation of the PCP, the benefits to both industry and regulatory individuals, and the issue created by crossover between persons serving as both Subject Matter Experts (SMEs) and trainers. The Committee discussed the difference between certification to demonstrate basic competency, accreditation, and licensing with continuing education requirements. The Committee believes that for the PCP to be accredited more information is needed about the specific accreditation requirements so the NCWM Professional Development Committee (NCWM PDC) can efficiently and correctly design the Program. The Committee encouraged the WWMA audience to take one or more of the three exams that are available. The Committee discussed the need for volunteer SMEs, exam results data and feedback on the exam taking experience, to assist the NCWM PDC in the continuous improvement of existing exams, and further development of future exams. Feedback can be submitted to the NCWM PDC through NCWM via e-mail to info@ncwm.net or call (402) 434-4880. The concept of free exams or a "rollback" in pricing for a period of time was discussed. There may be jurisdictions, business organizations, or other entities that desire to take the exams, but

find the cost of membership is prohibitive. The Committee believed there might need to be an initial incentive to encourage participation. The Committee recommends the following:

- NCWM survey jurisdictions to find out the number of Registered Service Agents (RSAs) within the jurisdiction, whether these jurisdictions require the RSA to pass an examination, and what fees and timelines are associated with these requirements. Determining the number of jurisdictions that require licensing and the content of their examinations (e.g., regulatory vs. technical requirements) would allow the NCWM PDC to evaluate the appropriateness of administering the same exams for RSAs or development of separate exams particular to RSAs. The jurisdictions using these written exams in their training programs could do so in conjunction with a field component to certify inspectors and RSAs.
- NCWM Executive Director continue research into the accreditation requirements and recommend the appropriate accreditation body for the PCP; weights and measures jurisdictions and industry organizations that may require certification recognize the value and credibility provided through formal accreditation.
- NCWM PDC continues its work refining the PCP FAQ Sheet. The WWMA PDC Committee is willing to assist with enhancing and clarifying this document. The PCP FAQ Sheet is a valuable tool for new exam takers.
- NCWM PDC consider implementing a policy of offering newly introduced exams at a reduced price for a fixed period of time (e.g., \$30 per exam for six months, providing the exam taker agree to provide feedback on the exam contents and exam taking experience before receiving their certificate). NCWM needs to encourage the widest possible participation in the early stages of PCP development. To bring the PCP to full program fruition, offering incentives to exam takers may assist the NCWM in reaching its goals.

One jurisdiction indicated that they would begin using the examinations as part of their annual performance plans and performance evaluations for their staff. The Committee realized that the PCP was originally designed for weights and measures officials, but discussed whether the exams should be modified for RSA to put more emphasis on proper calibrations, sealing, etc.

THIS PAGE INTENTIONALLY LEFT BLANK

Appendix C

History of Instructor Improvement

Source:

Carryover Item 401-3 (This item originated from the Committee and first appeared on its agenda in 2003.)

Background/Discussion:

Prior to the 2010 Annual Meeting, Ms. Georgia Harris, NIST, OWM provided the Committee with reference material on teaching methods and assessment of training success. Distilling the essence of these materials, the Committee believes that instructors need training in more than just the technical material; they need training in setting the learning objectives, developing the training materials with those objectives in mind, selecting training methods that incorporate adult learning styles, and evaluating the effectiveness of their training.

Education Subsystem

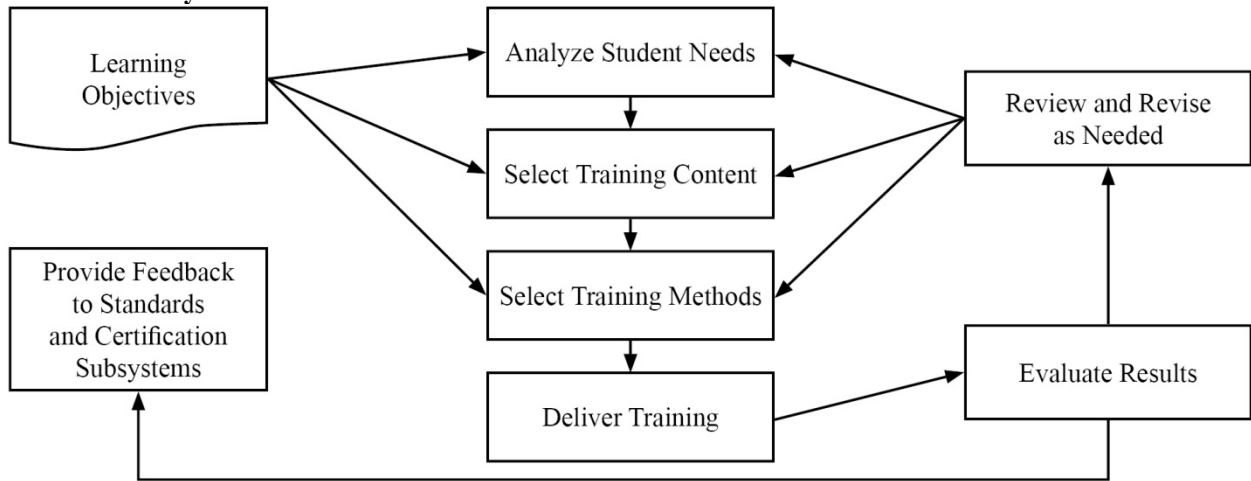

The chart below covers three levels of learning objectives and relates them to (1) the training activities most likely to be successful and (2) the best methods for assessing the success of the training. The curriculum segments state the learning objectives using verbs similar to those in the bottom row of the table. These drive both the training activities required to promote adult learning and the assessment tools appropriate to measure success at that level.

Assessments	Multiple Choice	Multiple Choice	Practical Examples Short Answer
Training Activities	Lecture Videos Examples	Discussion Review Learner Presentation	Exercises Simulations Demonstrations
Cognitive Levels	Knowledge	Comprehensive	Application
	Define Relate List	Restate Discuss Describe Identify	Employ Apply Use Illustrate

NIST, OWM has expressed strong interest in collaborating with NCWM in efforts to educate instructors in adult learning techniques and relating them to the learning objectives in NCWM curriculum. The Committee will be posting NIST, OWM material on converting technical content to training material on the PDC training resources

webpages. The importance of pre-training analysis and post-training evaluation cannot be overestimated. Failure to include these steps often leads to failure of training efforts.

Professional Certification Program
Systems Approach to Training Evaluation

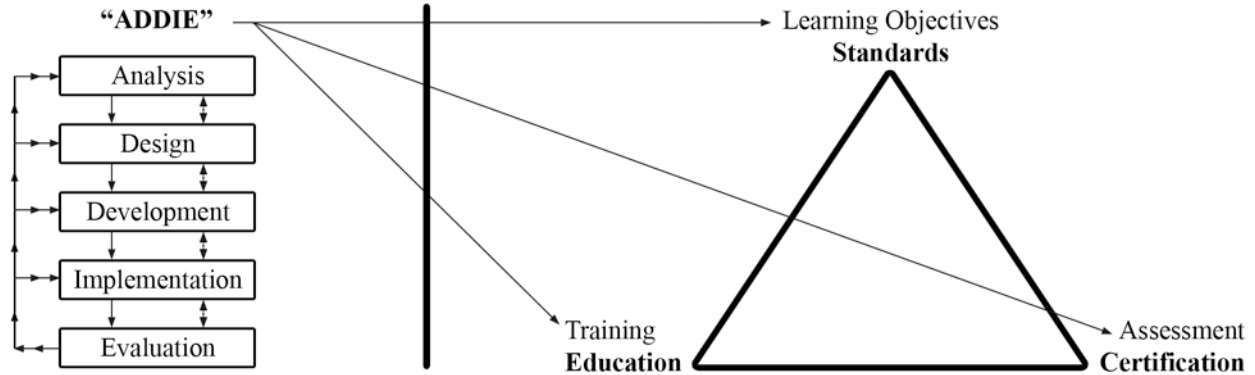

The Committee is calling on the states and other training developers to implement the Analysis, Design, Development, Implementation, and Evaluation (ADDIE) model in their training preparations and post training evaluation. Everyone needs to participate in the development of new BOK modules and then encourage their trainers to use existing BOK modules in their training plans.

The Committee encourages members to also look at the presentation on *A Complete Training Program* prepared by Ms. Carol, Hockert, NIST, OWM. The presentation outlines ways to develop training programs and improve instruction of weights and measures material. Contact Ms. Hockert for a copy.

2012 NCWM Interim Meeting: Advisors from NIST, OWM, reported that they are using NCWM BOK in preparing new training initiatives. They are stressing adult learning techniques, particularly focusing on the use of hands-on training as the most popular and effective training tool. This ties in closely with the new baseline competency exams discussed in Item 410-1. NIST, OWM is using these exams to ensure students in NIST sponsored training courses are competent in prerequisite course materials prior to taking training. They reported that they are already drafting questions for the baseline competency exams. They see significant efficiencies in using NCWM testing services for this purpose since they are already in place.

Ms. Hockert, NIST, OWM, recommended a basic math prerequisite for persons taking Metrology or other related weights and measures courses sponsored by NIST. The math exam would allow trainees to demonstrate entry level math skills and make the training process more efficient and effective. One official discussed the California licensing requirement of a college degree which requires a certain number of math courses and asked if this would satisfy the need for the math prerequisite. Several California officials expressed concern about the Professional Certification Program replacing existing state licensing programs, and if adopted, it might require amendment of existing state statutes. Because math competency is an essential skill for weights and measures work, the Committee recommends that the PDC include in its scope the development of an exam to demonstrate basic math competency before taking the Fundamentals of Metrology or other training courses at NIST.

2011 SWMA Annual Meeting: It was stated that we should consider training state trainers on adult learning techniques as well as subject matter. No further recommendations were made.

2012 NCWM Annual Meeting: The Committee stressed instructor improvement. The Committee reviewed the importance of using the NCWM learning objectives and the ADDIE model in training. This stresses the importance of training to the goals in the BOK and not training to pass the test. If the training is appropriate and has been delivered effectively, the employee should have no problem passing a fair exam. The end is not a certificate on the wall, but rather a competent inspector. In other words,

JOB SUCCESS = EXAM SUCCESS

Ms. Hockert stressed that good training requires a partnership between the trainee, trainer, and the supervisor. The Committee agrees that buy-in from all levels is critical to training success.

2012 CWMA Interim Meeting: The Committee recommended archiving most of the content in this item to the NCWM website as reference material.

2012 WWMA Annual Meeting: The Committee noted that it is in the best interest of NIST and NCWM that regional training efforts are of the highest quality and uniform throughout the United States. The Committee recommends the following:

- Regional trainers be selected as per the process agreed upon between NIST and NCWM;
- Regional trainers receive courses on adult learning techniques and converting technical information into training materials;
- Regional trainers be afforded the opportunity to shadow NIST trainers as they perform training in individual jurisdictions; and
- The use of funds from the Associate Membership Committee or the NIST Training Initiative Grant be made available for this purpose.

2012 NEWMA Interim Meeting: Members expressed interest in NIST Train-the-Trainer classes. A demonstration was provided on how to access materials for taking the Professional Certification Exams and then for taking the exams. The Committee encouraged those in attendance to seek certification of their inspectors.

THIS PAGE INTENTIONALLY LEFT BLANK

Report of National Type Evaluation Program (NTEP) Committee

Mr. Kurt Floren, Chairman
Los Angeles County Department of Agriculture
California

500 INTRODUCTION

This is the report of the NTEP Committee (hereinafter referred to as the “Committee”) for the 98th Annual Meeting of the National Conference on Weights and Measures (NCWM). This report is based on the Interim Report offered in the NCWM Publication 16, testimony heard at public hearings, comments received from the regional weights and measures associations and other parties, the addendum sheets issued at the Annual Meeting, and actions taken by the membership at the voting session of the Annual Meeting. The informational items presented below were adopted as presented when the Committee’s report was approved.

Table A identifies the agenda and appendix items. Agenda items are identified in the Report by Reference Key Number, Item Title, and Page Number. Item numbers are those assigned in the Interim Meeting agenda. A Voting item is indicated with a “V” after the item number. An item marked with an “I” after the reference key number is an Informational item. An item marked with a “D” after the reference key number is a Developing item. The developing designation indicates an item has merit; however, the item was returned to the submitter for further development before any action can be taken at the national level. Suggested revisions are shown in **bold** face print by ~~striking-out~~ information to be deleted and underlining information to be added. New items proposed for the handbook are designated as such by underscored bold face print, and nonretroactive items are indicated in *italics*. Table B lists the results of any voting items.

Note: It is the policy of the National Institute of Standards and Technology (NIST) to use metric units of measurement in all of its publications; however, recommendations received by NCWM technical committees and regional weights and measures associations have been printed in this publication as submitted. Therefore, the report may contain references in inch-pound units.

Subject Series List

Introduction	500 Series
International.....	510 Series
Activity Reports.....	520 Series
Conformity Assessment Program	530 Series
NCWM Publication 14, Administrative Policy	540 Series
Other Items – Developing Items	550 Series

**Table A
Table of Contents**

Reference Key	Title of Item	NTEP Page
500	INTRODUCTION	1
510	INTERNATIONAL	3
510-1	I Mutual Recognition Arrangement (MRA).....	3
510-2	I Mutual Acceptance Arrangement (MAA).....	4
520	ACTIVITY REPORTS.....	6
520-1	I NTEP Participating Laboratories and Evaluations Reports.....	6
520-2	I NTEP Sector Reports.....	6
530	CONFORMITY ASSESSMENT PROGRAM.....	8
530-1	I Conformity Assessment Program.....	8
530-2	I Conformity Assessment Program – NTEP Administrative Policy.....	11
540	NCWM PUBLICATION 14, ADMINISTRATIVE POLICY.....	12
540-1	I Administrative Policy Section Format.....	12
540-2	I Administrative Policy Section – NTEP Advisory Committee.....	13
540-3	I Administrative Policy Section – National Type Evaluation Program Technical Committees...	13
550	OTHER ITEMS – DEVELOPING ITEMS.....	14
550-1	D NTEP Contingency Plan.....	14

Appendices

A —	Item 520-1: NTEP Statistics Report	A1
B —	Item 520-2: NTETC Belt-Conveyor Scale Sector Meeting Summary.....	B1
C —	Item 520-2: NTETC Grain Analyzer Sector Meeting Summary	C1
D —	Item 502-2: NTETC Measuring Sector Meeting Summary	D1
E —	Item 520-2: NTETC Software Sector Meeting Summary	E1
F —	Item 520-2: NTETC Weighing Sector Meeting Summary	F1

**Table B
Voting Results**

<i>Reference Key Number</i>	<i>House of State Representatives</i>		<i>House of Delegates</i>		<i>Results</i>
	<i>Yeas</i>	<i>Nays</i>	<i>Yeas</i>	<i>Nays</i>	
To Accept the Report	Voice Vote				Adopted

Table C
Glossary of Acronyms and Terms

Acronym	Term	Acronym	Term
AQL	Acceptable Quality Level	MTL	Manufacturers' Testing Laboratories
B	Basic Publication	NCWM	National Conference on Weights and Measures
CC	Certificate of Conformance	NIST	National Institute of Standards and Technology
CIML	International Committee of Legal Metrology	NTEP	National Type Evaluation Program
CTT	Conformity to Type	NTETC	National Type Evaluation Technical Committee
DoMC	Declaration of Mutual Confidence	OIML	International Organization of Legal Metrology
IV	Initial Verification	OWM	Office of Weights and Measures
MAA	Mutual Acceptance Arrangement	R	Recommendation
MC	Measurement Canada	SC	Technical Subcommittee
MDMD	Multiple Dimension Measuring Devices	TC	Technical Committee
MRA	Mutual Recognition Arrangement	VCAP	Verification Conformity Assessment Program

Details of All Items
(In order by Reference Key)

510 INTERNATIONAL

510-1 I Mutual Recognition Arrangement (MRA)

Background/Discussion:

The MRA between Measurement Canada (MC) and NTEP labs originated April 1, 1994. Since that time, the original MRA has expanded, and a second MRA covering measuring devices was developed. On Tuesday, July 19, 2011, NCWM Chairman Mr. Tyson and MC President Mr. Johnston signed a renewal MRA that combines the weighing and measuring devices into one document and provides for continued cooperation between the two organizations and continuation of the beneficial partnership. The new MRA is effective for five years.

The scope of the current MRA includes:

- gasoline and diesel dispensers;
- high-speed dispensers;
- gasoline and diesel meters intended to be used in fuel dispensers and truck refuelers;
- electronic computing and non-computing bench, counter, floor, and platform scales with a capacity up to 1000 kg (2000 lb);

- weighing/load receiving elements with a capacity of up to 1000 kg (2000 lb);
- electronic weight indicating elements (except those that are software based (i.e., programmed by downloading parameters); and
- mechanical scales up to 10 000 kg (20 000 lb).

The Committee continues working with MC to explore the possibility of expanding the scope to include Multiple Dimension Measuring Devices (MDMD) and higher capacity scales. Technical obstacles have prevented inclusion of both MDMD and higher capacity scales for now, but NTEP and MC remain committed to continue to discuss expansion. NTEP also requested that tests conducted at manufacturers' premises under the supervision of an NTEP evaluator be included in the scope of the MRA. MC expressed the desire to keep these evaluations outside the scope of the MRA for scales, load receiving elements, and electronic weight indicating elements.

MC, NTEP, and all of our mutual stakeholders agree that the MRA is a benefit for the North American weights and measures industry. The NTEP Committee appreciates the efforts and cooperation of Measurement Canada.

NCWM private sector members continue to reiterate their desire to see Multiple Dimension Measuring Devices included under the MRA. Measurement Canada and the NTEP Committee continue to discuss and evaluate matters regarding such an expansion of the MRA.

2013 Annual Meeting: Measurement Canada agreed to give further consideration to expansion of the MRA to include MDMDs and to recognition of data collected by NTEP evaluators at manufacturing facilities.

Mettler-Toledo commented that their company has experienced MRA application issues due to differences in the test weights used for evaluation of high precision Class I and II balances. NTEP will discuss the issues with Measurement Canada.

510-2 I Mutual Acceptance Arrangement (MAA)

Background/Discussion:

Information regarding the International Organization of Legal Metrology (OIML) MAA can be found at www.oiml.org/maa. NCWM has signed the OIML MAA Declaration of Mutual Confidence (DoMC) for Recommendation (R) 60 Load Cells as a utilizing participant. A utilizing participant is a participant which does not issue any OIML Certificate of Conformance (CC) nor OIML Test Reports and/or Test Reports under a DoMC but does utilize the reports issued by issuing participants.

The OIML Technical Subcommittee (SC) for Technical Committee (TC) 3/SC 5 *Conformity Assessment* made revisions to the following OIML Basic Publication (B) documents:

- OIML B 3, *OIML Certificate System for Measuring Instruments*; and
- A combined revision of OIML B 10-1, *Framework for a Mutual Acceptance Arrangement on OIML Type Evaluations*, and OIML B 10-2, *Checklists for Issuing Authorities and Testing Laboratories carrying out OIML Type Evaluations*.

January 2011 Interim Meeting: The Committee reviewed four items related to the revisions of B 3 and B 10: (1) housekeeping revisions to document B 3; (2) housekeeping revisions to B 10; (3) revisions to B 10 that would incorporate provisions under which manufacturers' test data would be accepted under the MAA, and (4) a resolution of compromise whereby countries may voluntarily accept manufacturers' test data. The Committee recommended that the Board of Directors authorize the U.S. representative to vote YES on items (1) and (2), NO on item (3), and YES on item (4) with a qualifying statement that the United States would not accept any MAA certificates based on manufacturers' test data. The Board of Directors voted to support all of the recommendations from the NTEP Committee.

A meeting of the Committee on Participation Review for R 60 and R 76 was held September 21 - 23, 2011, in Braunschweig, Germany. Dr. Ehrlich, National Institute of Standards and Technology (NIST), Office of Weights and Measures (OWM); Mr. Barton, NIST, OWM; and Mr. Truex, NCWM attended the meeting.

The International Committee of Legal Metrology (CIML) Preliminary Ballots on B 3 and B 10 closed in July 2011 without any negative votes, and a final CIML vote was held at the CIML Meeting in Prague in October 2011. Both B 3 and B 10 passed the CIML vote. International comments on a new document entitled *The Role of Measurement Uncertainty in Conformity Assessment Decisions in Legal Metrology* have been received and the Secretariat is using them to develop the 2 Committee Draft (CD).

The CIML, noting the report of TC 3/SC 5 on the issue of the acceptance of manufacturers' test results within a DoMC under the MAA, and recalling its Resolution no. 20 at the 43rd CIML Meeting, decided that Issuing Participants may request the registration of Manufacturers' Testing Laboratories (MTLs) under a DoMC, provided that the conditions agreed by TC 3/SC 5 and laid down in a respective amendment to, or revision of, OIML B 10 are met, and that, after this amendment to, or revision of, OIML B 10, MAA Type Evaluation Reports that contain test results from MTLs may be accepted by Participants on a voluntary basis.

The CIML approved as a new work item for OIML TC 3/SC 5.

- The amendment to or the revision of, OIML B 10 Framework for a MAA on OIML Type Evaluations MAA to include appropriate conditions for the registration of MTLs under a DoMC.

The CIML also decided that the registration of MTLs under a DoMC remains excluded from the scope of the MAA until this amendment to, or revision of, OIML B 10 is approved. TC 3/SC 5 voted in May 2012 to approve a 2 CD of an Amendment to OIML B 10 that would permit, on a strictly volunteer basis, the use of test data from MTLs in the MAA. The United States (NTEP) supported this 2 CD with the provision that the use of manufacturer test data was clearly identified on the MAA test report because NTEP cannot use manufacturer test data towards issuance of an NTEP certificate. The 2 CD was modified accordingly, after which the CIML voted and approved the Amendment to B 10 to allow the inclusion of test data from manufacturers, on a strictly voluntary basis, at its October 2012 meeting in Bucharest, Romania.

Dr. Ehrlich gave an update to the Committee during the 2013 Interim Meeting, reviewing the history of the above discussions, deliberations, and CIML votes, confirming that the outcomes aligned with the Committee's recommendations and the instructions provided by the NCWM Board of Directors.

From January 2011 to December 2012, nineteen NTEP certificates for load cells were issued under the MAA. All to date have been tested by the National Measurement Institute in The Netherlands. The NTEP Administrator reviewed the test data and drafted the CCs.

Dr. Ehrlich requested in January that NCWM review its MAA policy regarding participation in R 76. The NCWM Board recapped the decision process to participate as a utilizing participant for R 60. Existing policy from 2006 is not to participate in R 76 until NCWM is able to do so as an Issuing Participant. The Board revisited the 2006 discussions leading to that decision, including considerations for NTEP labs' workload, potential lost expertise, concerns with quality of evaluations at some foreign labs, etc. Dr. Ehrlich wanted NCWM to reconsider and become a utilizing participant for OIML R 76. Some U.S. manufacturers support NCWM policy, but others would like to have one-stop shopping. The MAA also includes R 51 (water meters) and R 117 (RMFD) may be added soon. Since there are no new developments to effect the decision, the NCWM Board of Directors agree to maintain existing policy at this time.

520 ACTIVITY REPORTS

520-1 I NTEP Participating Laboratories and Evaluations Reports

Background/Discussion:

During the 2012 Annual Meeting, Mr. Truex, NTEP Administrator, updated the Committee on NTEP laboratory and administrative activities.

The NTEP weighing and measuring laboratories held a joint meeting April 2 - 5, 2012, in Columbus, Ohio. The NTEP weighing laboratories met again in August 2012 prior to the meeting of the NTEP Weighing Sector in Annapolis, Maryland, and the NTEP measuring laboratories met once more in October 2012, prior to the NTEP Measuring Sector meeting in Louisville, Kentucky.

The Committee announced plans to conduct a survey of NTEP customers and NTEP laboratories regarding customer service. The board plans to use the results of the survey to form a continuous improvement plan for NTEP. A small work group was formed to get the project started. The resulting draft was presented to the board during the 2011 Annual Meeting in Montana. With any survey, the challenge is to develop a document that is concise enough that customers will respond, while also providing a meaningful set of data. The survey was released to active CC holders. The NCWM Board of Directors reviewed the survey results in October 2011, finding general approval of NTEP services.

The New York brick and mortar NTEP laboratory for weighing devices is staffed and accepting NTEP evaluation assignments. The NTEP Committee realizes the other weighing laboratories worked very hard to assume additional workload while the NY laboratory was off line and commends the labs for keeping the backlog at a minimum and completing evaluations in a timely manner.

Mr. Truex reported to the Committee that incoming applications remain comparable to normal. He reported there is no backlog concern for measuring devices and the brick and mortar weighing labs at this time.

The NTEP laboratories, NTEP Committee, and NCWM Board of Directors expressed appreciation to Gilbarco for allowing the NTEP measuring laboratories to utilize their facilities and equipment for hands on training in April. Special thanks were extended to Gordon Johnson and Gilbarco employees that participated in the training exercises.

The Committee reviewed NTEP statistics through June 2013 (see Appendix A). The review of statistics shows that incoming applications are relatively comparable to normal, and there exist no significant laboratory backlog issues.

520-2 I NTEP Sector Reports

Background/Discussion:

All NTEP Sector reports were available to members at the time NCWM Publication 15 was published. The NTEP Committee is committed to ensuring that electronic versions of sector reports continue to be available with NCWM Publication 15 in the future. Please note that the sector reports will only be available in the electronic version of NCWM Publication 15 at ncwm.net/meetings/interim/archive; they will not be available in the printed versions of NCWM Publication 15. However, they will be included in all the *Report of the 98th National Conference on Weights and Measures* (NCWM Annual Meeting Reports).

NTEP Belt-Conveyor Scale Sector:

The NTEP Belt-Conveyor Scale Sector met February 22 - 23, 2012, in St. Louis, Missouri. A final draft of the meeting summary was provided to the Committee prior to the 2013 NCWM Interim Meeting for review and approval (see Appendix B).

The next meeting of the NTEP Belt-Conveyor Scale Sector had been scheduled for February 19 - 20, 2013, in Charlotte, North Carolina. The meeting was cancelled due to a lack of significant NTEP agenda items; however, a

meeting of the U.S. National Work Group was held. For questions on the current status of Sector work or to propose items for a future meeting, please contact the sector Technical Advisor:

Technical Advisor

Mr. John Barton
NIST, OWM
100 Bureau Drive, MS 2600
Gaithersburg, MD 20899-2600
Phone: (301) 975-4002
Fax: (301) 975-8091
E-mail: john.barton@nist.gov

NTEP Grain Moisture Meter and NIR Protein Analyzer Sectors:

The NTEP Grain Moisture Meter and NIR Protein Analyzer Sectors held a joint meeting in Kansas City, Missouri, August 22 - 23, 2012. A draft of the final summary was provided to the Committee prior to the 2013 NCWM Interim Meeting for review and approval (see Appendix C).

The next meeting of the NTEP Grain Moisture Meter and NIR Protein Analyzer Sectors is scheduled for August 21 - 22, 2013, in Kansas City, Missouri. NIST reported that their contract with Mr. Jack Barber, Co-Technical Advisor to the NTEP Grain Analyzer Sector, was not renewed. The sole Technical Advisor to the Sector is now Ms. Diane Lee. For questions on the current status of sector work or to propose items for a future meeting, please contact the Technical Advisor:

Technical Advisor

Ms. G. Diane Lee
NIST, OWM
100 Bureau Drive, MS 2600
Gaithersburg, MD 20899-2600
Phone: (301) 975-4005
Fax: (301) 975-8091
E-mail: diane.lee@nist.gov

NTEP Measuring Sector:

The NTEP Measuring Sector met October 5 - 6, 2012, in Louisville, Kentucky. A draft of the final summary was provided to the Committee prior to the 2013 NCWM Interim Meeting for review and approval (see Appendix D).

The dates for the NTEP Measuring Sector Meeting have been changed to October 9 - 10, 2013 in Charleston, West Virginia, at the same location as the Southern Weights and Measures Association's 2013 Annual Meeting. NIST reported that Mr. Butler, Technical Advisor to the NTEP Measuring Sector, has resigned his position at NIST. For questions on the current status of sector work or to propose items for a future meeting, please contact the Sector Technical Advisor:

Technical Advisor

To be Determined
NIST, OWM
100 Bureau Drive, MS 2600
Gaithersburg, MD 20899-2600
Phone: (301) 975-4615
Fax: (301) 975-8091
E-mail:

NTEP Software Sector:

The NTEP Software Sector met March 20 - 21, 2012, in Columbus, Ohio. A final draft of the meeting summary was provided to the Committee prior to the 2013 NCWM Interim Meeting for review and approval (see Appendix E).

The next meeting of the NTEP Software Sector is scheduled for March 19 - 20, 2013, in Columbus, Ohio. For questions on the current status of sector work or to propose items for a future meeting, please contact the sector Chair and/or the NTEP Administrator:

Chair

Mr. James Pettinato
FMC Technologies Measurement Solutions, Inc.
1602 Wagner Avenue
Erie, PA 16510
Phone: (814) 898-5250
Fax: (814) 899-3414
E-mail: jim.pettinato@fmcti.com

NTEP Administrator

Mr. Jim Truex
NCWM
1135 M Street, Suite 110
Lincoln, NE 68508
Phone: (740) 919-4350
Fax: (740) 919-4348
E-mail: jim.truex@ncwm.net

NTEP Weighing Sector:

The NTEP Weighing Sector met August 28 - 29, 2012, in Annapolis, Maryland. A final draft of the meeting summary was provided to the Committee prior to the 2013 NCWM Interim Meeting for review and approval (see Appendix F).

The next NTEP Weighing Sector meeting is scheduled for August 27 - 28, 2013, in Albany, New York. For questions on the current status of sector work, or to propose items for a future meeting please contact the Sector Technical Advisor:

Technical Advisor

Mr. Rick Harshman
NIST, OWM
100 Bureau Drive, MS 2600
Gaithersburg, MD 20899-2600
Phone: (301) 975-8107
Fax: (301) 975-8091
E-mail: richard.harshman@nist.gov

The NTEP Committee reviewed all 2012 NTEP Sector reports during the Interim Meeting. All reports were approved in their entirety.

530 CONFORMITY ASSESSMENT PROGRAM

530-1 I Conformity Assessment Program

Background/Discussion:

The Conformity Assessment Program was established to ensure devices produced after the device has been type evaluated and certified by NTEP continue to meet the same requirements. This program has three major elements: 1) Certificate Review (administrative); 2) Initial Verification (inspection and performance testing); and 3) Verified Conformity Assessment (influence factors). This item is included on the Committee's agenda to provide an update on these elements.

Certificate Review:

Certificates are constantly under review by NTEP staff and laboratories. Many active certificates are amended annually because of manufacturer submission for evaluation or issues reported by the states pertaining to information on the certificate. When the devices are re-evaluated and certificates are amended, all information is reviewed and necessary steps are taken to assure compliance and that accurate, thorough information is reported on the certificate.

In an effort to keep certificate information up to date, the Committee continues to offer an opportunity for active certificate holders to update contact information that is contained in the "Submitted By" box on certificates. This is

offered during the payment period of their annual maintenance fee. Many Certificate of Conformance (CC) holders have taken advantage of the opportunity.

Initial Verification (IV):

The IV initiative is ongoing. Field enforcement officials perform an initial inspection and test on new installations on a routine basis. The Committee recognized that the states do not want IV reporting to be cumbersome.

An IV report form has been developed. The Committee desired a simple form, perhaps web-based for use by state and local regulators. The form has been approved by the Committee and distributed to the states. A completed form can be submitted via mail, e-mail, fax, or online. The form is available to regulatory officials who are members of NCWM at www.ncwm.net/ntep/conformity/verification.

Verified Conformity Assessment Program (VCAP):

NCWM has been concerned about production meeting type and protecting the integrity of the NTEP CC since the inception of NTEP. The board has consistently reconfirmed its belief that conformity assessment is vital to NTEP’s continued success.

Load cells traceable to NTEP certificates were selected for the initial assessment effort. NCWM elected to require a systems audit checklist that is to be completed by an outside auditor and submitted to NCWM per Section 2.5 of the VCAP requirements. A VCAP Systems Audit Checklist for Manufacturers and a VCAP Systems Audit Checklist for Private Label Certificate Holders have been developed and are available on the website at www.ncwm.net/ntep/conformity/vcap/checklists-faqs. Additionally, the Committee developed a new NCWM Publication 14, administrative policy to distinguish between the requirements for parent NTEP certificate holders (S.1.c.) and private label certificate holders. The requirements in S.1.d. track the private label checklist requirements: traceability to parent NTEP CC, traceability of the private label cell to a VCAP audit, purchase, and sales records, plan to report non-conforming product and non-conforming product in stock, plan to conduct internal audits to verify non-compliance action, and internal audit records.

As a result of VCAP activities, 24 load cell certificates, involving 12 different certificate holders, were changed to “inactive” status.

The Committee announced that the next device category is weighing/load receiving elements, 1000 kg (2000 lb) capacity and less, using load cells that are not traceable to their own NTEP certificate. The following compliance timeline was developed for weighing/load receiving element CC holders with active certificates using non-NTEP load cells. The Committee encourages affected certificate holders to start the process immediately.

NCWM / NTEP VCAP Compliance Timeline					
Weighing/Load Receiving Element, 2000 lb Capacity and Less Using Non-NTEP Load Cells					
January 2012 – Ongoing	July 2012 – November 2013	July 2012 – May 2014	July 2012 – November 2013	December 2013	June 2014
<ul style="list-style-type: none"> • NTEP to review and refine VCAP procedures • NTEP answers incoming questions • NTEP notifies active CC holders of VCAP requirements 	<ul style="list-style-type: none"> • Parent CC holders to put VCAP QM system in place • CC holder to have audit conducted by Certified Body • Submit audit report to NCWM/NTEP 	<ul style="list-style-type: none"> • Private Label CC holders to put VCAP QM system in place • CC holder to have audit conducted by Certified Body • Submit audit report to NCWM/NTEP 	<ul style="list-style-type: none"> • NTEP evaluates incoming audit reports • NTEP contacts CC holders not meeting VCAP requirements to encourage compliance 	<ul style="list-style-type: none"> • NCWM declares CCs inactive if Parent CC holder fails to comply with VCAP 	<ul style="list-style-type: none"> • NCWM declares CCs inactive if Private Label CC holder fails to comply with VCAP

2013 NCWM Interim Meeting: it was reported that 25 weighing element certificate holders (46 active NTEP CCs) have been identified and all have been notified. The following disclaimer has been advertised and communicated by NCWM: "NCWM is working to identify all active certificates for weighing elements 1000 kg (2000 lb) capacity and less, using non-NTEP load cells. As a courtesy, certificate holders are being notified of VCAP requirements and the established time line. Please note that the NCWM Board of Directors does not consider it to be NCWM's responsibility to notify all certificate holders and affected certificates. Certificate holders are responsible for reviewing their active NTEP certificates and compliance with VCAP."

The Committee received two letters, a list of questions, and many other inquiries pertaining to VCAP. The Committee worked diligently to answer the questions submitted in a very timely manner. The Committee anticipated that additional questions would be posed and considered the potential need to form a VCAP Committee. Certificate holders and other interested parties were encouraged to submit written questions to the NTEP Committee so decisions could be made regarding the need for a VCAP Committee and, if needed, the make-up of the group. The Committee is pleased to report that it was successful in answering all the questions to date. Clerical changes have been made to affected VCAP documents.

Recurring questions involve the five remaining device types under the VCAP umbrella. When will these remaining device types be added to the VCAP program? Will they be added all at one time or only a single device type every two to three years? The Committee is very carefully considering possible options. With each device type added to the VCAP, the administrative overhead of NTEP increases proportionately. At the present time, additional device types cannot be added until increased capacity within NTEP administration is achieved. The NCWM Board is currently reviewing alternatives to this increase in capacity, including consideration of an option to add all of the remaining device types at one time. There is no formally accepted schedule for completion of this effort.

Seven weighing device categories subject to influence factors, as defined in NIST Handbook 44, were identified and are subject to VCAP audits. The VCAP process requirement is ongoing for load cells and weighing elements that use non-NTEP load cells. The five remaining device categories are: indicating elements, complete scales, automatic weighing systems, belt-conveyor scales, and automatic bulk weighing systems. Certificate holders for these device types are encouraged to take note that the NTEP Committee and NCWM Board is seriously considering the application of the VCAP requirement to all five remaining categories in the very near future. If and when the VCAP requirements are applied the certificate holder would be required to have an on-site audit of the manufacturer's quality system and on-site random and/or review of a production device by an outside auditor to verify compliance with VCAP. Certificate holders are encouraged to research the VCAP requirements on the NCWM website under the NTEP, Conformity Assessment section. Certificate holders are encouraged to review the VCAP requirements applicable to their devices and report concerns to the NTEP Committee.

There was discussion on the required number of audits for facilities that manufacture multiple device types. For example, if a company had successful audits for two device types, they might submit a request for a delay from audit requirements for remaining device types, stating that they are all subjected to the same processes and will be audited in the next cycle. The Committee agreed to the request in principal and directed the NTEP Administrator to develop NCWM policy language for consideration during the next Board meeting.

Cardinal Scale suggested that all additional device categories subject to VCAP be included under the VCAP umbrella all at once and in the near future. The NCWM NTEP Committee and Board of Directors want to again stress to NTEP Certificate holders that they must pay attention to the continued progress of VCAP as it applies to their devices. Certificate holders are encouraged to expand their current VCAP audit certification to include the other device categories likely to be included under the VCAP umbrella in the near future.

NTEP Staffing for VCAP Workload: Comments on the proposal to hire another NTEP staff person have been positive. The Board discussed the extensive travel requirements for the person and reviewed the duties and desired qualifications. The decision was made to advertise the position with applications due by July 31, 2013, and the goal to have the person on staff sometime in November.

530-2 I Conformity Assessment Program – NTEP Administrative Policy

Source:

NTEP Committee

Purpose:

Clarify the intent of NCWM Publication 14, *Administrative Policy*, Conformity Assessment Process.

Item Under Consideration:

The 2013 Version of NCWM Publication 14 reflects these changes.

S.1.c. NTEP Verified Conformity Assessment Program Procedures

Introduction

Many NTEP certified devices must meet NIST Handbook 44 requirements for influence factors. It is not possible to verify these requirements during the Initial Verification in the field. Therefore, manufacturers of metrological devices (instruments) and/or components (modules) which are subject to influence factors, as defined in NIST Handbook 44, must have a Verified Conformity Assessment Program (VCAP) in place to ensure that these metrological devices and/or components are produced to perform at a level consistent with that of the device and/or component previously certified.

The Verified Conformity Assessment Program audit will be at one or more sites as required to verify compliance.

For weighing devices that are subject to influence factors, NTEP will require an initial on-site audit of the manufacturer's quality system and on-site random testing and/or review of a production device(s) (instrument[s]) by the Registrar to verify that all items listed below are currently implemented and functioning to verify compliance to the appropriate sections of NIST Handbook 44.

It is important for NTEP to know the types of devices included in the VCAP audit and it is for this reason that the certificate holder shall prepare a controlled Quality Management System (QMS) document listing the range of parameters that cover the devices included in the audit. The certificate holder shall include in this document all certificates and device parameters (For example: different models, capacities, e-min, n-max, sizes etc.) for the applicable device category. For example, in a load cell audit, a range of capacities of the load cells included in the audit shall be listed in the report. This document shall be available for the VCAP auditor and NTEP upon request and may be included as an annex to the audit report if desired.

Amend Section S.1.c.1.4. as follows:

1.4 An appropriate sampling plan and acceptance criteria is in place and operating.

1.4.1. The NTEP CC holder shall establish a random sampling plan appropriate for the production quantity of the device that is traceable to a nationally recognized quality standard, i.e., Acceptable Quality Level (AQL) or equivalent, or meet the minimum requirements as defined in Section 4 of this document.

1.4.2. **The NTEP CC holder shall maintain a controlled document listing all the devices, their estimated annual production quantity, the CC number of the device and the date that the device was added to or removed from the sampling plan.**

1.4.23. Devices shall be selected and tested in accordance to *NCWM Publication 14* as designated by the established sampling plan.

1.4.34. Results of the testing, along with values of pertinent control parameters (e.g., time, temperature, humidity, etc.), shall be recorded and shall clearly identify whether the test passed or failed.

1.4.45. Records shall be made available to the VCAP auditor of test results since the last VCAP audit.

Amend Section S.1.d as follows:

d. NTEP Verified Conformity Assessment Program Procedures for Private Label Certificate Holders

Introduction

Many NTEP certified devices must meet NIST Handbook 44, *Specifications, Tolerances, and Other Technical Requirements for Weighing and Measuring Devices*, requirements for influence factors. It is not possible to verify these requirements during the Initial Verification in the field. Therefore, manufacturers of metrological devices (instruments) and/or components (modules), which are subject to influence factors, as defined in NIST Handbook 44, must have a Verified Conformity Assessment Program (VCAP) in place to ensure that these metrological devices and/or components are produced to perform at a level consistent with that of the device and/or component previously certified.

For weighing devices that are subject to influence factors, traceable to a private label NTEP Certificate of Conformance, NTEP will require the private label certificate holder to verify that the parent certificate holder has complied with VCAP requirements, has a current VCAP audit certificate, the VCAP certification is traceable back to the parent NTEP certificate, and the parent certificate is active.

It is important for NTEP to know the types of devices included in the VCAP audit and it is for this reason that the certificate holder shall prepare a controlled Quality Management System (QMS) document listing the range of parameters that cover the devices included in the audit. The certificate holder shall include in this document all certificates and device parameters (for example: different models, capacities, e-min, n-max, sizes etc.) for the applicable device category. For example, in a load cell audit, a range of capacities of the load cells included in the audit shall be listed in the report. This document shall be available for the VCAP auditor and NTEP upon request and may be included as an annex to the audit report if desired.

Amend Sections S.1.d.1. by adding a new Section 1.3. as follows and renumbering subsequent sections:

1.3. The private label certificate holder shall maintain a controlled document listing all the private label devices, the suppliers' name and the date the private label agreement was initiated or cancelled.

Background/Discussion:

It has been recommended to the Committee that the VCAP requirement and other conformity assessment documents be clarified. The amendments proposed above reflect the primary significant changes. The Committee discussed the recommended changes and concluded they were clerical in nature and did not affect the integrity of VCAP or change the intent of the VCAP requirements. If the changes above are accepted, it will be necessary to incorporate the changes into the two checklists (parent CC holder and private label CC holder), the VCAP supplemental guide, and other electronic documents on the NCWM website as deemed appropriate.

The Committee did not receive any negative comments about the proposed changes. During the Interim Meeting, the Committee recommended to the NCWM Board that the changes be accepted and incorporated into the 2013 version of NCWM Publication 14. The Board approved the recommendation and authorized NTEP to move forward accordingly.

540 NCWM PUBLICATION 14, ADMINISTRATIVE POLICY

540-1 I Administrative Policy Section Format

Source:

NTEP Committee

Purpose:

Revise the format of NCWM Publication 14, *Administrative Policy* section by converting to a numbering format and putting content in more logical order.

Background/Discussion:

NCWM is working to revise NCWM Publication 14, *Administrative Policy* to arrange content in a more logical order and to develop a more understandable form. The purpose is not to change the intent of the publication, but to realign and clarify sections as necessary. During 2012, NTEP Sectors and the NTEP labs were asked to review the revised section, "NTEP Administrative Policy," and provide feedback. An electronic copy of the revised document was shared with members of the Sectors and NTEP lab representatives.

The Committee did not receive any negative comments about the proposed changes. During the Interim meeting, the Committee recommended to the NCWM Board that the changes be accepted and incorporated into the 2013 version of NCWM Publication 14. The Board approved the recommendation and authorized NTEP to move forward accordingly. The 2013 version of NCWM Publication 14 reflects these changes.

540-2 I Administrative Policy Section – NTEP Advisory Committee

Source:

NTEP Committee

Purpose:

Update NCWM Publication 14, *Administrative Policy* (A.10. and B.5.) to reflect current practice.

Item Under Consideration:

Amend NCWM Publication 14, *Administrative Policy* as follows:

Delete sections A.10. and B.5. providing for an "NTEP Advisory Committee."

~~**A.10. NTEP Advisory Committee—An ad hoc committee that reviews long range plans and recommends policy changes to the NTEP Committee.**~~

~~**B.5. The Advisory Committee is an ad hoc committee that recommends policy and long range planning to the NTEP Committee. The Advisory Committee meets as needed and is made up of members appointed by the NTEP Committee Chair, representing all segments of NCWM.**~~

Background/Discussion:

The NTEP Committee was unable to verify that an NTEP Advisory Committee has ever been officially appointed by any NTEP Committee Chair. The charges of long range planning and policy changes are fulfilled by the NCWM Board of Directors. The Committee did not receive any negative comments about the proposed changes. During the Interim Meeting, the Committee recommended to the NCWM Board that the changes be accepted and incorporated into the 2013 version of NCWM Publication 14. The Board approved the recommendation and authorized NTEP to move forward accordingly.

540-3 I Administrative Policy Section – National Type Evaluation Program Technical Committees

Source:

NTEP Committee

Purpose:

Change the name of the Sectors from "National Type Evaluation Technical Committee" (NTETC) to "NTEP Sectors."

Item Under Consideration:

The 2013 Version of NCWM Publication 14 reflects these changes.

A.14. National Type Evaluation ~~Technical Committee~~ Program Sector (~~NTETC~~NTEP Sector)

A Committee that develops and recommends test criteria and procedures to the NTEP Administrator, known as a “Sector” (e.g., Weighing Sector).

B.3. National Type Evaluation ~~Technical Committee~~ Program Sector (~~NTETC~~ NTEP Sector)

The National Type Evaluation ~~Technical Committees~~ Program Sectors (~~NTETC~~ or NTEP Sectors) have the responsibility of advising the NTEP Administrator by developing and recommending test criteria and procedures for use in the evaluation process by the Participating Laboratories. The ~~NTETC~~ NTEP Sectors also may recommend specific changes to NIST Handbook 44 to assure consistency between the handbook and the checklist published in NCWM Publication 14.

Meetings are held annually, or as needed and are open to all NCWM members and other registered parties. An ~~NTETC~~ NTEP sector seeks to form a consensus among all parties in attendance. Sectors are formed to address specific device areas of NTEP (e.g., weighing, measuring, grain moisture). Each Sector has a chairperson that is appointed by the NTEP Committee Chair. There is no fixed term for this position. The ~~NTETC~~ NTEP Sector Chair must be a current member of NCWM.

If for any reason an ~~NTETC~~ NTEP Sector member cannot attend the scheduled meeting, he/she may designate an alternate, with prior approval of the ~~NTETC~~ NTEP Sector Chair. This alternate will have the same voting rights as the ~~NTETC~~ Sector member they replace, for that particular meeting.

The membership and voting status of the ~~NTETC~~ NTEP Sector is as follows:

Background/Discussion:

The term “National Type Evaluation Technical Committee (NTETC)” has reportedly led to confusion by many individuals over the years. The Committee believes that changing the name to “NTEP Sectors” may simplify understanding and reflect the role of the Sectors. The Committee acknowledges that, if the name change is approved, references to NTETC throughout NCWM Publication 14 will need to be changed. The Committee did not receive any negative comments about the proposed changes. During the Interim Meeting, the Committee recommended to the NCWM Board that the changes be accepted and incorporated into the 2013 version of NCWM Publication 14. The Board approved the recommendation and authorized NTEP to move forward accordingly.

550 OTHER ITEMS – DEVELOPING ITEMS

550-1 D NTEP Contingency Plan

Source:

NTEP Committee

Purpose:

NTEP Contingency Plan was created to keep NTEP operating and to ensure that NTEP services are available at an adequate level including an appropriate number of laboratories and personnel (evaluators) to maintain viable support for NTEP services, including MRAs, MAAs, and potentially to be an R 76 Issuing Participant.

Item Under Consideration:

The NTEP Committee discussed contingency planning for continuity of NTEP operations. With the state of today’s economy, one of the NTEP-authorized labs could close due to government budget cuts. How would NTEP maintain workflow? Are there additional states interested in applying to become an NTEP field lab or an NTEP brick-and-mortar lab? The Committee will continue to discuss these issues during a long-range planning session and welcomes comments from the membership.

Background/Discussion:

The Committee continues to consider whether NCWM should:

1. Employ NTEP evaluators to conduct testing at manufacturers' facilities?
2. Have evaluators under contract to conduct testing at manufacturers' facilities?
3. Employ NTEP evaluators or have evaluators under contract to assist the state NTEP laboratories?
4. Have a brick and mortar NTEP laboratory and NTEP evaluators?
5. Use a private third party laboratory to conduct NTEP evaluations?

The Committee has heard testimony expressing support and concerns pertaining to the options. Several stated that the Committee should consider adding OIML MAA participation as a Utilizing Participant to the list. Others have urged the Committee to continue working on the idea of NCWM NTEP evaluators, an NCWM NTEP lab, and keeping all options open. One member asked the Committee to consider accepting manufacturer compliance data in lieu of hiring NTEP contractors. Another suggestion from the floor was to consider strengthening and utilizing IV as part of the NTEP process. A representative of a state brick and mortar NTEP laboratory asked the Committee to move cautiously forward and not destroy the state NTEP labs. He expressed concern that the establishment of an NCWM NTEP brick and mortar lab could lead to significant legal complications for the states.

The Committee reiterated to the membership that, at this time, the preferred course of action would be the option of evaluators under contract. The Committee recognizes the commitment that the states with NTEP laboratories have made over the years and would only resort to contingency measures in the event of a severe loss of state lab resources. Labs are handling current demands without a need for contingency measures. The Committee is updated on the status of the participating laboratories, personnel, and backlog on a quarterly basis and will continue to keep NTEP contingency a priority.

Mr. Kurt Floren, Los Angeles County, California | Committee Chair
Mr. Stephen Benjamin, North Carolina | NCWM Chairman
Mr. John Gaccione, Westchester County, New York | Chairman-Elect
Mr. Ron Hayes, Missouri | Member
Mr. James Cassidy, City of Cambridge, Massachusetts | Member

Mr. Jim Truex, NCWM | NTEP Administrator

National Type Evaluation Program Committee

THIS PAGE INTENTIONALLY LEFT BLANK

Appendix A

NTEP Statistics Report

General NTEP Statistics	Last Year	This Year	Grand Total
	10/01/11 – 6/30/12	10/01/12 – 6/30/13	10/1/00 – 6/30/13
Total Applications Processed	(21) 204	(8) 185	(152) 3216
Applications Completed	210	194	3080
New Certificates Issued	195	193	2788
Active NTEP Certificates on 3/31/2012	1896	1977	

() = Reactivations

Assignments to Labs per Year	10/1/11 – 9/30/12	10/1/12 – 6/30/13	10/1/00 – 6/30/13
California	27	33	(16) 441
Canada	7	1	(4) 44
GIPSA-DC	1	1	17
GIPSA-KC	10	6	93
Kansas	2	0	(9) 70
Maryland	(9) 61	(6) 33	(43) 401
New York	2	(1) 7	(18) 170
NIST Force Group	6	1	(1) 89
North Carolina	13	6	(4) 118
Ohio	(13) 53	43	(28) 820
NTEP Staff	(1) 92	(2) 35	(12) 875
Applications Not Yet Assigned to a Lab			3

() = Reassignments from another lab

Process Statistics	2012 - 2013	2000 - 2013
Average Time to Assign an Evaluation	4 Days	9 Days
Average Time to Complete an Evaluation		137 Days

Report on Evaluations in Progress

Evaluations in Progress	0-3 Months	3-6 Months	6-9 Months	9-12 Months	Over 1 Year	Total
June 2009	48	27	17	12	29	133
October 2009	41	33	18	12	33	137
December 2009	45	30	22	12	28	137
March 31, 2010	24	20	18	19	23	104
June 30, 2010	37	12	11	13	24	97
October 30, 2010	40	30	8	8	20	106
December 31, 2010	39	25	22	5	20	111
March 31, 2011	37	27	13	19	17	107
June 30, 2011	47	20	7	7	21	102
September 30, 2011	42	28	11	5	19	105
December 31, 2011	37	19	23	5	17	101
March 31, 2012	40	17	7	21	14	99
June 30, 2012	41	21	10	6	20	98
September 30, 2012	50	30	15	7	19	121
December 31, 2012	32	24	17	7	18	98
March 31, 2012	36	12	14	12	18	92
June 30, 2013	53	18	6	6	19	102

In Progress by Lab	0-3 Months	3-6 Months	6-9 Months	9-12 Months	Over 1 Year	Total
California	18	1	2	1	4	26
Canada	0	0	0	0	0	0
GIPSA-DC	0	0	0	0	1	1
GIPSA-KC	6	0	0	0	1	7
Maryland	8	3	0	2	3	16
New York	2	1	0	0	0	3
NIST Force Group	0	0	0	0	4	4
North Carolina	2	2	0	0	2	6
Ohio	10	10	4	3	4	31
NTEP Staff	3	1	0	0	0	4
Unassigned	4	0	0	0	0	4
Total Pending:						102

Report on Applications Received by Quarter

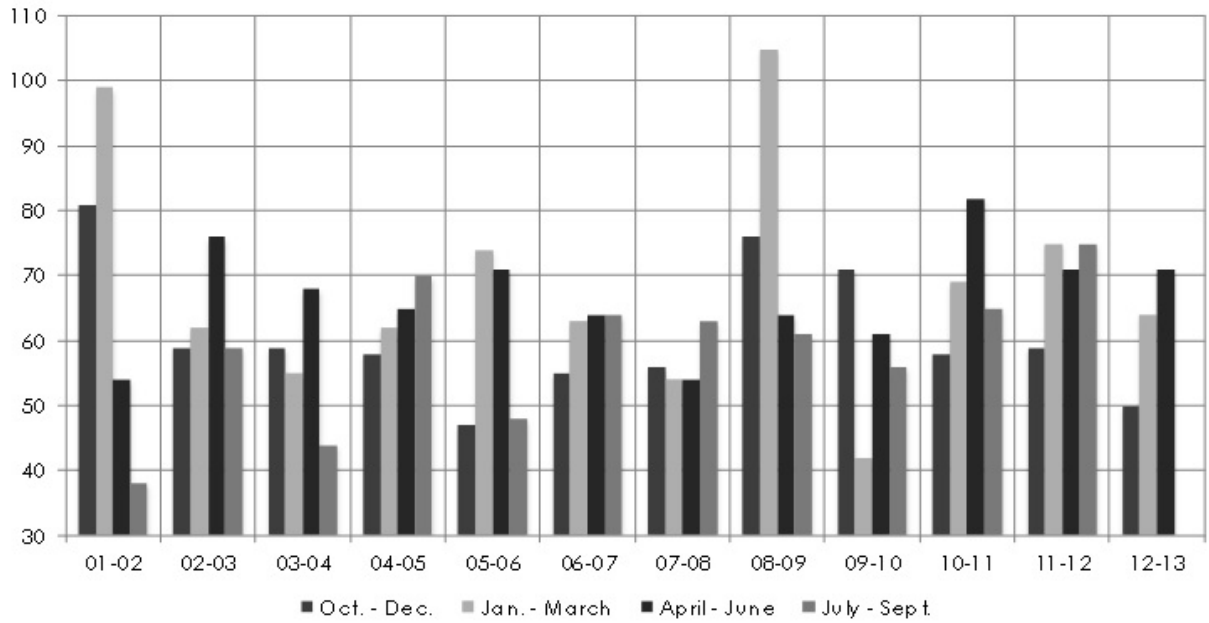

	01-02	02-03	03-04	04-05	05-06	06-07	07-08	08-09	09-10	10-11	11-12	12-13
Oct - Dec	81	59	59	58	47	55	56	76	71	58	59	50
Jan - Mar	99	62	55	62	74	63	54	105	42	69	75	64
Apr - Jun	54	76	68	65	71	64	54	64	61	82	71	71
Jul - Sep	38	59	44	70	48	64	63	61	56	65	75	
Total	272	256	226	255	240	246	227	306	230	274	280	185

Average Per Quarter Overall: 63.8

Average Per Quarter This FY: 61.7

THIS PAGE INTENTIONALLY LEFT BLANK

Appendix B

National Type Evaluation Technical Committee (NTETC) Belt-Conveyor Scale (BCS) Sector Meeting Summary

February 23, 2012
St. Louis, Missouri

INTRODUCTION

The charge of the BCS Sector is important in providing appropriate type evaluation criteria based on specifications, tolerances and technical requirements of NIST Handbook 44 Sections 1.10. General Code and 2.21. Belt-Conveyor Scale Systems. The Sector’s recommendations are presented to the NTEP Committee each January for approval and inclusion in NCWM Publication 14, *Technical Policy, Checklists and Test Procedures* for national type evaluation.

The Sector is also called upon occasionally for technical expertise in addressing difficult NIST Handbook 44, *Specifications, Tolerances, and Other Technical Requirements for Weighing and Measuring Devices* issues on the agenda of the National Conference on Weights and Measures (NCWM) Specifications and Tolerances Committee. Sector membership includes industry, NTEP laboratory representatives, technical advisors and the NTEP Administrator. Meetings are held annually, or as needed and are open to all NCWM members and other registered parties.

Suggested revisions are shown in **bold face print** by ~~striking out~~ information to be deleted and underlining information to be added. Requirements that are proposed to be nonretroactive are printed in *bold faced italics*.

Note: It is the policy of the National Institute of Standards and Technology (NIST) to use metric units of measurement in all of its publications; however, recommendations received by NCWM technical committees and regional weights and measures associations have been printed in this publication as submitted. Therefore, the report may contain references in inch-pound units.

Table A
Table of Contents

Title of Content	NTEP Appendix B – Page
INTRODUCTION	1
CARRY-OVER ITEMS	2
1. Belt-Conveyor Scale NTEP Checklist	2
2. Sealable Parameters List for NTEP Evaluation	3
3. Linearization Feature for BCS	3
4. Conveyor Belt Profiling	4
NEW ITEMS	5
5. 2012 NIST Handbook 44 Changes	5
6. Recommended Changes to Existing Language in NCWM Publication 14	6
6.a. 9. Installation Requirements - paragraph numbering (page BCS-11)	6
6.b. Minimum Test Load (MTL) References	6
a. 6. Zero-Setting Mechanism (page BCS-7)	6
b. 6. Zero-Setting Mechanism (page BCS-8)	7
c. 7. Sensitivity at Zero Load (page BCS-8)	7
d. 12. Laboratory Test Procedures (page BCS-14 and 15)	7

e. 15. Data Sheet and Laboratory Test Procedure (page BCS-20 and 21).....8

7. Field Test Procedures for Reference Scales.....9

 7.a. Hopper Scales – 13. Field Test Procedure(page BCS - 17)9

 7.b. Railway Track Scales – 13. Field Test Procedure (page BCS - 17).....10

8. Time and Date Information Required on Recorded Indications11

9. Short Conveyor Belt (Weigh-Belts) Systems12

ATTENDANCE13

Table B
Glossary of Acronyms and Terms

Acronym	Term	Acronym	Term
BCS	Belt-Conveyor Scale	NTEP	National Type Evaluation Program
MTL	Minimum Test Load	NTETC	National Type Evaluation Technical Committee
NCWM	National Conference on Weights and Measures	OWM	Office of Weights and Measures
NIST	National Institute of Standards and Technology	USNWG	U.S. National Work Group

Details of All Items
(In order by Title of Content)

CARRY-OVER ITEMS

1. Belt-Conveyor Scale NTEP Checklist

Source:
 NIST, OWM

Background/Discussion:

Prior to the 2009 NTETC BCS Sector Meeting, Mr. Ripka, Chair submitted a draft of an amended NCWM Publication 14, *Belt-Conveyor Scales Technical Policy, Checklists, and Test Procedures* to the sector members for review. The changes in this draft related primarily to Master Weight Totalizers intended to be installed as substitutions within a BCS system in addition to a number of other minor editorial changes. Among the suggested changes that were included in this draft were proposed changes involving procedures used when evaluating semi-automatic and automatic zero-setting mechanisms.

This proposed draft has not been sufficiently vetted yet. That draft was offered for use on a trial basis by NTEP laboratories when evaluating manufacturer’s replacement instruments that are scheduled to undergo NTEP evaluation. Some manufacturers within the Sector have indicated that they may have instruments ready to be submitted to NTEP for evaluation.

NTEP laboratories have agreed to use the amended checklist in order to identify gaps or necessary changes within the draft. Feedback from evaluators who have used this amended checklist is needed so that the Sector can determine if the proposed changes need further development. Any input and additional comments that are available will be discussed.

NTEP evaluator Mr. Jones, California Division of Measurement Standards, informed the Sector that there have not been any submissions of BCS Totalizers from manufacturers that could serve as a model unit to apply this amended checklist to on a trial basis.

Belt-conveyor scale manufacturer representatives from Thermo Fisher Scientific and Merrick Industries, Inc. informed the Sector that they anticipate submitting devices to NTEP for evaluation in the near future. These manufacturers stated that their devices should be appropriate models to be used to evaluate the draft procedures.

Conclusion:

The Sector agreed that upon the application of the new draft test procedures, a report would be made to the Sector by the NTEP evaluator(s) detailing any gaps in the procedures and further amendments if necessary. The amended checklist will be applied to these instruments when they become available.

2. Sealable Parameters List for NTEP Evaluation

Source:

NIST, OWM

Background/Discussion:

A list of BCS features and parameters that were identified by the Sector as those that should be protected by a form of security seal had been developed during the 2009 NTETC BCS Sector Meeting. The list has been forwarded to NTEP laboratories who have agreed to use this list during NTEP evaluation of BCS to determine if the list is sufficiently comprehensive. Feedback from NTEP evaluators using this amended checklist is requested so that sector members are able to determine if the list is sufficient. Any additional input and comments available from manufacturers and NTEP evaluators on the proposed changes will be discussed.

The Sector was informed that although the sealable parameters list developed during the 2009 NTETC BCS Sector Meeting is in the current NCWM Publication 14, there have not been any instruments submitted for evaluation under NTEP that provide the opportunity to compare this list to.

Conclusion:

The Sector agreed that the list as developed at the 2009 NTETC BCS Sector Meeting will remain in NCWM Publication 14 in its current form, and will be updated as needed based on any gaps identified by NTEP evaluators.

3. Linearization Feature for BCS

Source:

NIST, OWM

Background/Discussion:

Manufacturers and service agents of belt-conveyor scales have voiced support for the use of electronic instruments equipped with a linearity correction feature (i.e., multiple point calibrations) to reduce span errors that deviate from a linear pattern. It has been reported by some sector members that this practice may be in conflict with the prohibition of this type of feature by certain weights and measures regulatory authorities. Some sector members have asked for clarification from the National Institute of Standards and Technology (NIST), Office of Weights and Measures (OWM) on the use of this type of feature and whether it is (or should be) permitted in existing U.S. standards. The U.S. National Work Group (USNWG) on BCS has deliberated on the use of a linearization feature for enhancing the performance of belt-conveyor scale systems and considered whether there is a need to develop requirements within NIST Handbook 44 to address its use. Test procedures (including those used for type evaluation) are to be analyzed and further developed or amended as needed in order to verify that this feature will comply with the current NIST Handbook 44. Manufacturers at the 2011 NTETC BCS Sector Meeting agreed to participate in a work group formed to develop a draft of test procedures that could be submitted to the NTEP Committee as proposed changes within NCWM Publication 14. This work group will also consider the scope for the application of any newly developed test procedures (i.e. whether the test procedures will be applied retroactively to devices that have already received NTEP approval). The work group includes the following members:

- Mr. Bill Ripka, Thermo Fisher Scientific
- Mr. Peter Sirrico, Thayer Scale / Hyer Industries
- Mr. Lars Marmsater, Merrick Industries, Inc.
- Mr. Ian Burrell, Control Systems Technology Pty Ltd.

The work group agreed to continue work on developing test procedures through correspondence and offer a draft for review by the Sector. An update on any progress that has been made in this effort will be provided to the Sector.

The Sector recognizes that linearization correction features may at this time be in use in some manufacturer's devices. The Sector also understands that manufacturers may take different approaches in the design of such features and that it would be impractical to write a single set of procedures to follow during type evaluation of different manufacturer's devices.

Mr. Barton, NIST Technical Advisor suggested that a simple, generic statement may be all that is needed to provide the evaluator with the information necessary (e.g., a statement that would direct the evaluator to follow procedures that are provided by the manufacturer).

Mr. Marmsater, Merrick Industries, Inc. noted that many electronic components used in the construction of belt-conveyor scale systems become obsolete very rapidly and this causes the manufacturer to redesign the instruments to accommodate necessary changes in design. He questioned whether this will require that a reevaluation be performed at the time of these redesigns. Mr. Truex, NTEP Administrator acknowledged that this could be a potential problem and that NTEP, and if necessary, NTEP Committee would properly address this issue.

Conclusion:

The Sector agreed that the same work group that originally took on the linearization feature project during the 2011 NTETC BCS Sector Meeting will regroup and continue the work to produce a rough draft of procedures to be followed when evaluating the instruments ability to compensate for non-linear performance. This rough draft is to be completed by May 31, 2012, and then circulated to the Sector for review and comment.

4. Conveyor Belt Profiling

Source:

NIST, OWM

Background/Discussion:

This method of establishing a zero-condition for a totalization operation enables the belt-conveyor scale to synchronize the application of an individual "tare" weight values associated with distinct segments of the belt to the movement of those belt segments over the scale portion of the conveyor. If this alternative to averaging the weight of segments of the belt carcass is used there is a potential need to establish a procedure to evaluate its effectiveness, to ensure that it functions as intended, and is maintained during operation of the BCS.

NIST OWM has received inquiries seeking guidance on whether this type of feature is permitted under U.S. standards. It is also being reported by some members of the USNWG BCS that some regulatory field officials will not issue an approval for devices equipped with this feature when it is not listed as a standard feature or an option on the NTEP Certificate of Conformance.

During the 2011 NTETC BCS Sector Meeting the Sector was asked to consider if there is a need for procedures to evaluate the effectiveness of belt profiling and to ensure that correct operation is maintained during totalization. A majority of Sector members voiced their opinion that this feature should receive some level of evaluation, and that at a minimum the ability to enable or disable any belt-profiling feature should be protected by some form of security seal.

The Sector also concluded that it might be preferable to have the analysis and necessary action(s) for the consideration of belt profiling features taken on by the same work group formed under the previous agenda item.

The work group is comprised of the same members as the work group formed under the previous agenda item and includes:

- Mr. Bill Ripka, Thermo Fisher Scientific
- Mr. Peter Sirrico, Thayer Scale/Hyer Industries
- Mr. Lars Marmsater, Merrick Industries, Inc.
- Mr. Ian Burrell, Control Systems Technology Pty Ltd.

A draft of test procedures is expected to be made available for review by the Sector. An update on any progress made by the work group will be provided to the Sector.

At the 2011 NTETC BCS Sector Meeting, the work group reported that no progress has been made on developing a draft for test procedures to evaluate belt profiling features.

Conclusion:

The Sector agreed that there is merit to incorporating guidance for NTEP evaluators by providing procedures for testing this feature. They agreed that the same group that originally took on the project will regroup and continue the work to produce a rough draft of procedures to be followed when evaluating a belt-profiling type of feature. This rough draft will be completed by May 31, 2012, and will be circulated to other sector members for review and comment.

NEW ITEMS

5. 2012 NIST Handbook 44 Changes

Source:

NIST, OWM

Background/Discussion:

The proposed amendments were presented to the sector members and an explanation was provided for necessary changes that are being recommended.

Conclusion:

The 2012 edition of NIST Handbook 44 BCS code contains an amended paragraph N.3.1.3. After a review of the suggested changes, there were no opposing comments from the Sector. It is recommended that NCWM Publication 14 be changed to reflect this amendment as shown below:

13. Field Test Procedure (page BCS-18)

Field Performance Test of the Belt-Conveyor Scale

N.3.1.3. Check for Consistency of the Conveyor Belt Along Its Entire Length. – During a zero-load test with all operational ~~no~~ **low**-flow lockout disabled, the total change indicated in the totalizer during ~~one~~ **any complete** revolution of the belt shall not exceed the absolute value of 0.12 % of the minimum ~~test~~ **totalized** load. ~~The end value of the zero-load test must meet the ± 0.06 % requirement (Test for Zero Stability). After a zero-load test with flow rate filtering disabled, the totalizer shall not change more than plus or minus (± 3 d) 3.0 scale divisions from its initial indication during one complete belt revolution.~~

Note: The end value of the zero-load test must meet the ± 0.06 % requirement referenced in the “Test for Zero Stability.”

(Added 2002) (Amended 2004 and 2011)

6. Recommended Changes to Existing Language in NCWM Publication 14

6.a. 9. Installation Requirements - paragraph numbering (page BCS-11)

Source:

NIST, OWM

Background/Discussion:

The proposed amendments were presented to the sector and an explanation was provided for necessary changes that are being recommended.

Conclusion:

The Sector was asked to consider that the paragraph numbers within NCWM Publication 14 be changed to correspond with the previous renumbering of paragraphs in Section 9. There were no opposing comments. Suggested amendments are shown below:

Code Reference: UR.2.2.1.

- 9.7.3. Pulleys, if used, must be properly protected from material build-up. Yes No N/A
- 9.7.4. If the tail pulley rides on a carriage, the guides must be protected against material build-up. Yes No N/A
- 9.7.5. If the arrangements in ~~(3)~~ **(9.7.3.)** and ~~(4)~~ **(9.7.4.)** are used, then the bridle attaching the cable to the carriage must be designed such that the carriage will not become cocked in its guides or tracks. Yes No N/A

6.b. Minimum Test Load (MTL) References

Source:

NIST, OWM

Background/Discussion:

When the value for MTL in NIST Handbook 44 [2.21. Belt-Conveyor Scale Systems], paragraph N.2.3.(a) was changed from 1000 scale divisions to 800 scale divisions in the 2005 edition of NIST Handbook 44, not all corresponding values in NCWM Publication 14 were changed.

Conclusion:

The proposed amendments were presented to the Sector and explanations were provided for necessary changes that are being recommended. There were no opposing comments. To reconcile these NCWM Publication 14 references with current NIST Handbook 44 requirements, it is recommended that MTL references in NCWM Publication 14 Belt-Conveyor Scales Checklist be changed as shown, from 1000 d to 800 d in the following locations:

a. 6. Zero-Setting Mechanism (page BCS-7)

Code Reference: S.3.1. and S.3.1.1.

The zero-setting mechanism may be either a manual or automatic mechanism. In either case, the range of the zero-setting mechanism is limited to $\pm 2\%$ of the rated capacity of the scale. If a greater adjustment is needed, the access to the adjustment must be through some security means. An audio or visual signal shall be given when the automatic and semi-automatic zero-setting mechanisms reach the limit of adjustment of the zero-setting mechanism. The zero-setting mechanism must be constructed such that the zero-setting operation is done only after a whole number of belt revolutions (a minimum of 3 revolutions or a time period equivalent to the time required to deliver ~~1000~~ **800** d of load.) The completion of the zero-setting operation must be indicated. The low-flow lockout must be deactivated for this test.

b. 6. Zero-Setting Mechanism (page BCS-8)

- 6.3. The zero-setting operation shall be performed only after at least 3 Yes No N/A belt revolutions or a time period equivalent to the time required to deliver ~~1000~~ 800 d of load.

c. 7. Sensitivity at Zero Load (page BCS-8)

Test Procedure

Apply a load equal to the weight required to determine compliance with the Belt-Conveyor Scale Code paragraph S.3.2. based upon the equation:

$$\frac{2 * W_c}{C_m}$$

For Example: $\frac{2 * \del{500} \u{400} \text{ lb}}{\del{1000} \u{800} \text{ d}} = 1 \text{ lb}$

d. 12. Laboratory Test Procedures (page BCS-14 and 15)

Voltage Tests

5. Run an accuracy test at 98 % of scale capacity for the time to deliver ~~1000~~ 800 d.
6. Change the voltage of the power supply to 100 V.
7. Run a zero test.
8. Run an accuracy test at 98 % of scale capacity for the time to deliver ~~1000~~ 800 d.
9. Change the voltage of the power supply to 130 V.
10. Run a zero test.
11. Run an accuracy test at 98 % of scale capacity for the time to deliver ~~1000~~ 800 d.
12. Return the voltage of the power supply to a nominal value.

Percent of Static Scale Capacity	Nominal Time (minutes)	Equivalent Belt Travel ¹
0	20 minutes, or $MTL_{min}/[(0.35)(BL_{min})$ (belt speed for test)] ¹ whichever is greater	
35 % of SSC _{min}	20 minutes, or $MTL_{min}/[(0.35)(BL_{min})$ (belt speed for test)], whichever is greater	
35 % of SSC _{max}	Time to deliver 1000 <u>800</u> d	
70 % of SSC _{max}	Time to deliver 1000 <u>800</u> d	
98% of SSC _{max}	Time to deliver 1000 <u>800</u> d	
Leave the scale under load for 1 hour.		
98 % of SSC _{max}	Time to deliver 1000 <u>800</u> d	
70 % of SSC _{max}	Time to deliver 1000 <u>800</u> d	
35 % of SSC _{max}	Time to deliver 1000 <u>800</u> d	
35 % of SSC _{min}	20 minutes, or $MTL_{min}/[(0.35)(BL_{min})$ (belt speed for test)], whichever is greater	
0	20 minutes, or $MTL_{min}/[(0.35)(BL_{min})$ (belt speed for test)] ² whichever is greater	

e. 15. Data Sheet and Laboratory Test Procedure (page BCS-20 and 21)

Device Parameters		Abbreviations	Maximum	Minimum	Dim.
Load per unit length (from manufacturer) corresponds to the largest capacity and the lowest capacity rating.		BL			lb/ft
Length of the weighbridge (inches.)					in
Belt speed (from manufacturer.)		SP			ft/min
Determine scale capacity in units per hour $SC = SP \times BL \times 60/2000$		SC			ton/hr
Record the static scale capacity in units of weight. $SSC = (\text{maximum weight per foot}) \times (\text{length of weighbridge})$		SSC			lb
Allowable zero error for temperature change of 10 °C (18 °F) $AZE = (0.0007) (SC_{\min}) (\text{time})/60$ where "time" is the time of the zero test in minutes.		AZE			ton
Size of scale division required for zero.		SD			ton
Determine the minimum and maximum totalized loads.		MTL			ton
Test Conditions		Abbreviations	Maximum	Minimum	Dim.
Determine the time in minutes to acquire MTL with the test load to be applied in laboratory testing.	Test load, pound/foot.				lb/ft
	Test load, total.				lb
	Time (minutes) to deliver MTL (at least 10 minutes.)	time			min
Determine number of belt travel sensor revolutions required for the above time. Manufacturer to provide revolutions per foot or pulses per foot as appropriate to determine 3 belt revolutions and a delivery of 1000 800 d (from manufacturer.)		BTR			Revolutions
Allowable weighing error (units of weight) for dynamic tests which will be divisions on master weight totalizer (MWT.) $AWE = 0.45(0.005)(TL)$		AWE			ton

Percent of Static Scale Capacity	Time (minutes)	Totalized Load TL (ton)	Tolerance AWE = 0.45 (.005) (TL)
0	20 minutes, or $MTL_{min}/[(0.35)(BL_{min})]$ (belt speed for test), whichever is greater		
35 % of SSC_{min}	20 minutes, or $MTL_{min}/[(0.35)(BL_{min})]$ (belt speed for test), whichever is greater		
35 % of SSC_{max}	*Time to deliver 1000 800 d		
70 % of SSC_{max}	*Time to deliver 1000 800 d		
98 % of SSC_{max}	*Time to deliver 1000 800 d		
Leave the scale under load for 1 hour.			
98 % of SSC_{max}	*Time to deliver 1000 800 d		
70 % of SSC_{max}	*Time to deliver 1000 800 d		
35 % of SSC_{max}	*Time to deliver 1000 800 d		
35 % of SSC_{min}	20 minutes, or $MTL_{min}/[(0.35)(BL_{min})]$ (belt speed for test), whichever is greater		
0	20 minutes, or $MTL_{min}/[(0.35)(BL_{min})]$ (belt speed for test), whichever is greater		

7. Field Test Procedures for Reference Scales

7.a. Hopper Scales – 13. Field Test Procedure(page BCS – 17)

Source:

NIST, OWM

Background/Discussion:

The required minimum test weights of 10% of scale capacity as stated in NCWM Publication 14 does not correspond with the minimum test weight required in NIST Handbook 44 [2.20. Scales], Table 4 of 12.5 %. The Sector is asked if these values should be reconciled.

Sector members agreed that the minimum test weight amount of 10 % of scale capacity is in conflict with NIST Handbook 44 Scales Code, Table 4 where it is required that, for scales of greater than 3000 lb capacity the minimum test weight required is 12.5 % of scale capacity. The origin of the established value of 10 % is uncertain at this time. Mr. Barton, NIST Technical Advisor offered that the possible source for this value may have been from the stated value for minimum test weight in the NIST Handbook 44 [2.24.] Automatic Bulk Weighing Systems code where that type of device is required to be tested using 10 % of scale capacity as the minimum test weight.

The Sector originally agreed that this reference to 10 % minimum test weight required should be amended to coincide with the minimum test weight required under Table 4 – NIST Handbook 44 Scales Code (e.g., 12 % of scale capacity). Further discussion by the Sector disclosed that no requirement is present in NIST Handbook 44 BCS code to specify the capacity of a reference scale used and that the only specific requirement is that the scale used must produce weighments within 0.1 % accuracy.

Conclusion:

The amendments shown below were agreed upon by the Sector which specify that no more than three substitutions can be used during the testing of a hopper scale used a reference scale, and that the hopper scale be tested according

to NIST Handbook 44 procedures. The Sector recommends the changes as shown below be made in NCWM Publication 14.

13. Field Test Procedure (page BCS-17)

Test of the Reference Scale

Hopper Scales

Hopper scales must be tested to the used capacity using a maximum of three substitution tests according to NIST Handbook 44 procedures. ~~Test weights equal to a minimum of 10 % of scale capacity are needed; more test weight is recommended.~~ The scale must be accurate to 0.1 % and adjusted if necessary.

Notice: After the 2012 NTETC BCS Sector Meeting, Mr. Barton, NIST Technical Advisor received feedback regarding concerns about this item and decision reached by the Sector. These concerns were specifically related to the deletion of a stated minimum required test weight and the apprehension that this type of scale may be tested using test weight in amounts that are smaller than what has been established as minimum. Mr. Ripka, Chair and Mr. Truex, NTEP Administrator were consulted, with a decision reached that since this is not a critical issue currently preventing a manufacturer from completing an NTEP evaluation, it would be best to hold as a carry-over item to be re-addressed at the next Sector meeting.

7.b. Railway Track Scales – 13. Field Test Procedure (page BCS-17)

Source:

NIST, OWM

Background/Discussion:

The Sector was asked to provide input regarding a recommendation that uncoupled in-motion railway scales used to establish reference weights for material tests be required to be tested in the mode (in-motion or statically) that will be used to determine the reference weights.

As written, this procedure does not prohibit weighing rail cars, uncoupled in-motion, to obtain reference weights for use during a material test when the railway scale's accuracy has only been verified through static testing. Considering the substantial time and effort involved in testing an uncoupled in-motion railway scale, it is questionable whether the scale will be properly tested as an in-motion scale (when used as such) or if it will only have its accuracy verified through a statically performed test.

The Sector was asked if the railway track scale is not tested as an in-motion scale, should it be accepted that the scale will be capable of producing reference weights of 0.1 % accuracy when the scale is used as an in-motion scale. Several sector members expressed their belief that reference weights can be obtained on an in-motion scale that has had its accuracy verified however; the weights should be obtained by static weighing only. This notion was based on the uncertainty whether in-motion weighing can consistently produce 0.1 % accuracy for all weighments.

Mr. Burrell, Control Systems Technology Pty Ltd. pointed out that to exclude the use of in-motion weighing from acceptable methods to obtain reference weights would be placing unfair limitations on technological advancements. He further stated that static type scales cannot be absolutely relied on to accurately produce weighments without error. Other sector members expressed the view that they are not aware of any tests being performed where reference weights are obtained by in-motion weighing.

Conclusion:

The Sector agreed that no action be taken on this recommendation, and that the current language in NCWM Publication 14 should not be amended.

13. Field Test Procedure (page BCS-17)

Test of the Reference Scale

Railway Track Scales

Because of the difficulties of obtaining adequate test weights or test cars to test railway track scales, the American Association of Railroads Committee simply recommends that the scales be tested the best way that can be arranged. The scale must be accurate to 0.1 % and adjusted if necessary.

Split-draft static-weighing is acceptable. ~~Uncoupled in-motion weighing is permitted if it is done as a single draft.~~

8. Time and Date Information Required on Recorded Indications

Source:

NIST, OWM

Background/Discussion:

The 2012 USNWG on BCS Meeting included discussion regarding paragraph S.1.4. in NIST Handbook 44 BCS code which requires that recorded indications include the date and time in addition to the initial and final totalizer reading and the unit of measurement.

The statement of date and time however is non-specific in that there is no association made for the date and time record with the stage that the totalization process is in.

This issue has also been included in the agenda for the NTETC BCS Sector Meeting; due to the reference to this NIST Handbook 44 requirement in NCWM Publication 14. The example of a recorded indication provided in NCWM Publication 14 (shown below) indicates a single, unspecified date and time. It may be reasonable to assume that because the total quantity is also provided on the recorded indication, that the date and time shown are associated with the final MWT reading.

2. Recording Element (page BCS-5)

Code Reference S.1.4. and G-S.5.2.2.:

- 2.3. The value of the scale division of the recording element shall be the same as that of the indicating element. The belt-conveyor scale system shall record the initial indication and the final indication on the MWT, the quantity delivered, the unit of measurement, (e.g., kilograms, tonnes, pounds, tons, etc.), the date, and time. This information shall be recorded for each delivery. The indicated and recorded weight values must agree to the nearest scale division. Yes No N/A
- 2.4. All weight values shall be recorded as digital values. Yes No N/A
- 2.5. Information required on the ticket. Yes No N/A

	05-06-92
	15:30
MASTER START TOTAL	44113.5 T
MASTER STOP TOTAL	44300.5 T
QUANTITY	187.0 T

The Sector is asked to consider whether it is useful to include a time and date for the recorded indications of both the initial MWT reading and the final MWT reading. Additionally, is there justification for providing enough information on the recorded indications to establish a span of time for the delivery of the total amount of material?

If it is determined that an amendment is needed to the NIST Handbook 44 requirement, it is recommended that the Sector draft the appropriate necessary changes to NCWM Publication 14.

The Sector generally agreed that there is some justification for providing sufficient information on recorded indications to be able to determine the amount of time that has passed during a totalization of material and that this amount of time could easily be obtained by referencing a time and date indication on both the beginning and final totalization recorded indication. Some sector members noted however, that recorded information that is already required to be indicated on flow chart recorders will provide that information. Other sector members agreed and added that it has been their experience that the flow chart recordings are always available for inspection as required.

Conclusion:

Considering the limited amount of space on many typical printed tickets that is available for the required recorded (printed) information, the Sector agreed not to support that additional information be required on the printed/recorded indications and that no changes to NCWM Publication 14 should be recommended with regard to this issue.

9. Short Conveyor Belt (Weigh-Belts) Systems

Source:

NIST, OWM

Background / Discussion:

The 2012 USNWG BCS Meeting Agenda include the reintroduction of language in NIST Handbook 44 under UR.2. regarding shorter belt systems that are designed and furnished by the manufacturer. This proposal would place language back into NIST Handbook 44 that had been stricken in 2001.

Although this language is not in the current edition of NIST Handbook 44, reference to NIST Handbook 44 in the current NCWM Publication 14 still includes this deleted wording. The Sector is asked to consider how to reconcile NCWM Publication 14 with references to requirements in NIST Handbook 44.

Conclusion:

The Sector acknowledged there is on-going work regarding this issue being done by a sub-group of the U.S. National Work Group on belt-conveyor scales, which may result in changes to future editions of NIST Handbook 44. The Sector agreed however, that any references made in NCWM Publication 14 to requirements contained in NIST Handbook 44 should mirror the existing language in those requirements. They also agreed to recommend that the following amendments be made to NCWM Publication 14 to reflect existing language in NIST Handbook 44.

9. Installation Requirements (page BCS-11)

Code Reference: UR.2.2.1.

- 9.7. ~~Unless the scale is installed in a short conveyor designed and furnished by the scale manufacturer or built to the scale manufacturer's specifications, the conveyor shall comply with the following minimum requirements: The design and installation of the conveyor leading to and from the belt-conveyor scale is critical with respect to scale performance. The conveyor can be horizontal or inclined, but if inclined, the angle shall be such that slippage of material along the belt does not occur. Installation shall be in accordance with the scale manufacturer's instructions and the following:~~ Yes No N/A

- 9.7.1. If the belt length is such that a take-up device is required, Yes No N/A
this device shall be of the counter-weighted type for either
vertical or horizontal travel.
9.7.1.1. Indicate the Type: Vertical Horizontal

ATTENDANCE

James Alexander
SME Scales DTE Energy
6200 W. Warren
Detroit, MI 48210
(313) 897-1143
jalexander@dteenergy.com

Arthur Amslor
Arcadia Controls, Inc.
392Plains Church Road
Cranberry Twp., PA 16066
(724) 538-8931
artarcadia@aol.com

John Barton
NIST, Office of Weights and Measures
100 Bureau Drive, MS 2600
Gaithersburg, MD 20899
(301) 975-4002
john.barton@nist.gov

Ian Burrell
Control Systems Technology Pty, Ltd
37 Stanley Street
Peakhurst, NSW 2210
Australia
+61 295844500
iburrell@controlsystems.com.au

Phil Carpentier
PTC Consulting, LLC
2697 Arbor Drive
White Bear Lake, MN 55110
(651) 429-7491
ptcarpentier@comcast.net

Paul Chase
Chase Technology, Inc.
502 Erie Ave.
Crosby, MN 56441
(218) 545-2356
mjc@crosbyironton.net

Nathan Gardner
State of Oregon Measurement Standards
635 Capital Street NE
Salem, OR 97301
(503) 881-4586
ngardner@oda.state.or.us

Ken Jones
California Division of Measurement Services
6790 Florin Perkins Road, Suite 100
Sacramento, CA 95828
(916) 229-3052
kjones@cdfa.ca.gov

Lars Marmsater
Merrick Industries, Inc.
10 Arthur Drive
Lynn Haven, FL 32444
(850) 271-7829
lars@merrick-inc.com

Al Page
Montana Highlands
2316 Canyon Drive
Billings, MT 59102
(406) 861-0534
awp8866@gmail.com

Bill Ripka
Thermo Fisher Scientific
501 90th Ave NW
Minneapolis, MN 55433
(800) 445-3503
bill.ripka@thermofisher.com

Peter Sirrico
Thayer Scale / Hyer Industries
91 Schoosett Street
Pembroke, MA 02359
(781) 826-8101 x328
psirrico@thayerscale.com

NTEP Committee 2013 Final Report
Appendix B – NTETC 2012 Belt-Conveyor Scale Sector Meeting Summary

Fred Steinbacher

State of Montana Weights and Measures
P.O. Box 200516
Helena, MT 59620
(406) 439-4241
fmdplus3@g.com

James Truex

National Conference on Weights and Measures
88 Carryback Drive
Pataskala, OH 43062
(740) 919-4350
jim.truex@ncwm.net

Appendix C

National Type Evaluation Technical Committee (NTETC) Grain Analyzer Sector Meeting Summary

August 22 - 23, 2012
Kansas City, Missouri

INTRODUCTION

The charge of the NTETC Grain Analyzer Sector is important in providing appropriate type evaluation criteria based on specifications, tolerances and technical requirements of NIST Handbook 44, *Specifications, Tolerances, and Other Technical Requirements for Weight and Measuring Devices*, Sections 1.10. General Code, 5.56. Grain Moisture Meters and 5.57. Near-Infrared Grain Analyzers. The Sector’s recommendations are presented to the National Type Evaluation Program (NTEP) Committee each January for approval and inclusion in NCWM Publication 14, *Technical Policy, Checklists, and Test Procedures* for national type evaluation.

The Sector is also called upon occasionally for technical expertise in addressing difficult NIST Handbook 44 issues on the agenda of National Conference on Weights and Measures (NCWM) Specifications and Tolerances (S&T) Committee. Sector membership includes industry, NTEP laboratory representatives, technical advisors, and the NTEP Administrator. Meetings are held annually, or as needed and are open to all NCWM members and other registered parties.

Suggested revisions are shown in **bold face print** by ~~striking-out~~ information to be deleted and underlining information to be added. Requirements that are proposed to be nonretroactive are printed in ***bold faced italics***.

Note: It is the policy of the National Institute of Standards and Technology (NIST) to use metric units of measurement in all of its publications; however, recommendations received by NCWM technical committees and regional weights and measures associations have been printed in this publication as submitted. Therefore, the report may contain references in inch-pound units.

Table A
Table of Contents

Title of Content	NTEP Appendix C – Page
INTRODUCTION	1
1. Report on the 2012 NCWM Interim and Annual Meetings	3
2. Report on NTEP Evaluations and Ongoing Calibration Program (OCP) (Phase II) Testing	3
3. Review of OCP (Phase II) Performance Data	4
4. Amend Table S.2.5. of §5.56.(a) in NIST Handbook 44.....	5
4.a. Proposed Changes to Table S.2.5. in Appendix C of the GMM Chapter of NCWM Publication 14.....	7
4.b. Proposed Changes to the Checklist of the GMM chapter of NCWM Publication 14.....	8
4.c. Proposed Changes to the Checklist of the NIR Grain Analyzer Chapter of NCWM Publication 14.....	9
5. Modify the Definition of Remote Configuration Capability Appearing in Appendix D of NIST Handbook 44 to Recognize the Expanded Scope of “Remote Configuration Capability”	9
6. Test Weight per Bushel Acceptance and Maintenance Tolerances.....	10

7.	Report on International Organization of Legal Metrology (OIML) TC 17/SC 1 R 59 Moisture Meters for Cereal Grains and Oilseeds.....	12
8.	Update on Efforts to Establish Recognized Traceability under the International Committee of Weights and Measures (CIPM) Mutual Recognition Agreement (MRA) for Moisture in Grain Measurements.	13
9.	Report on OIML TC 17/SC 8 Protein Measuring Instruments for Cereal Grain and Oil Seeds	14
10.	Item 356-1 Printed Ticket User Requirements - Update	15
11.	Update on Proficiency Testing.....	17
12.	NCWM Publication 14, NTEP Administrative Policy Changes	18
13.	Next Sector Meeting	19
14.	Review of Form 15s	19
15.	Update on the New Meter Technology	19

Table B
Glossary of Acronyms and Terms

Acronym	Term	Acronym	Term
BIML	International Bureau of Legal Metrology	NTETC	National Type Evaluation Technical Committee
CD	Committee Draft	OCP	Ongoing Calibration Program
CIML	International Committee of Legal Metrology	OIML	International Organization of Legal Metrology
CIPM	International Committee of Weights and Measures	OWM	Office of Weights and Measures
D	Document	R	Recommendation
EMRP	European Metrology Research Program	S&T	Specifications and Tolerances
FGIS	Federal Grain Inspection Service	SC	Subcommittee
GA	Grain Analyzer	SD	Secure Digital
GIPSA	Grain Inspection, Packers and Stockyards Administration	TC	Technical Committee
GMM	Grain Moisture Meter	TW	Test Weight
MRA	Mutual Recognition Agreement	UGMA	Universal Grain Moisture Algorithm
NCWM	National Conference on Weights and Measures	USB	Universal Serial Bus
NIR	Near Infrared Grain Analyzer	USDA	United States Department of Agriculture
NIST	National Institute of Standards and Technology	USNWG	United States National Working Group
NTEP	National Type Evaluation Program		

Details of All Items
(In order by Reference Key)

1. Report on the 2012 NCWM Interim and Annual Meetings

The 2012 NCWM Interim Meeting was held January 22 - 25, 2012 in New Orleans, LA. At that meeting, the NTEP Committee accepted the Sector's recommended amendments and changes to the 2011 Edition of NCWM Publication 14. These changes appear in the 2012 Edition.

The changes are detailed in the table below. For additional background/details refer to Agenda Item 4 in the Sector's August 2011 Meeting Summary.

The 2012 NCWM Annual Meeting was held July 16 - 19, 2012, in Portland, Maine. There were no Grain Analyzer Sector Voting Items on the agenda. **Item 351-1, UR.3.4. Printed Tickets** remains an Informational Item on the NCWM Agenda. See Grain Analyzer Agenda Item 10, below, for details.

Mr. Jim Truex, NTEP Administrator, reported that attendance this year at both the Interim and Annual Meetings was better than that of the last few years. Paid membership in the NCWM is now in the 2200 to 2300 range.

Amendments/Changes to the Grain Moisture Meters Chapter in the 2011 Edition of NCWM Publication 14			
Section Number	Amendment/Change	Page (2011 Edition)	Source: 2011 Grain Analyzer Sector Meeting Summary
§ II. Sample Temperature Sensitivity	Amend §II to accommodate cold grain temperatures down to –0 °C and to specify the conditions under which an intermediate manufacturer-specified cold grain temperature must be specified.	GMM-2	Agenda Item 4.a.
Appendix A Test: Sample Temperature Sensitivity	Modify Sample Temperature Sensitivity Test to reflect the expanded cold grain temperatures described in § II.	GMM-34	Agenda Item 4.b.
Appendix E – Sample Temperature Sensitivity	Modify Sample Temperature Sensitivity Test for grains/oilseeds other than corn, soybeans and hard red winter wheat to reflect the expanded cold grain temperatures described in § II.	GMM-45	Agenda Item 4.c.
GMM Checklist 3. Code Reference: S.1.3. Operating Range	Add Paragraph 3.10.2.1 to require that grains or seeds with an extended temperature range neither display nor print moisture results if outside applicable moisture OR temperature ranges.	GMM-19	Agenda Item 4.d.

2. Report on NTEP Evaluations and Ongoing Calibration Program (OCP) (Phase II) Testing

Ms. Cathleen Brenner, Grain Inspection, Packers and Stockyards Administration (GIPSA), brought the Sector up to date on NTEP Evaluation (Phase I) activity. Renovation of the laboratory is nearly complete. The process of moving and installing the environmental chamber, air ovens, and other equipment into the new area will begin

shortly after Labor Day. Because of the renovations, the laboratory has been without an environmental chamber for over a year. Once the move is underway, the NTEP lab can begin accepting applications for Phase I testing.

Ms. Brenner also reported on the collection and analysis of Grain Moisture Meter OCP (Phase II) data on the 2011 crop. For the 2012 harvest there are seven models enrolled in Phase II. (Perten Instruments elected not to continue model AM5100 in Phase II this year. Their CC for the AM5100 will expire in June 2013.) The manufacturers will be charged on the basis of six models because, using GAC2500-UGMA data, DICKEY-john can automatically back calculate calibrations to the GAC2500 without having to run samples on the GAC2500*. Phase II data collection for the 2012 harvest began in early August.

The seven meters:

1. Bruins Instruments – OmegAnalyzerG
2. DICKEY-john Corp. – GAC2000 (NTEP Version), GAC2100a and GAC2100b
3. DICKEY-john Corp. – GAC2500 (*See note above. Will not run samples on this model.)
4. DICKEY-john Corp. – GAC2500-UGMA
5. Foss North America – Infratec 1241
6. Perten Instruments Inc. – AM5200 and AM5200-A (The AM5200-A is UGMA Certified.)
7. The Steinlite Corporation – SL95

The 2012 Phase II enrollment cost to each manufacturer, based on 6 device types, is \$8,750.

3. Review of OCP (Phase II) Performance Data

At the Sector’s August 2005 meeting it was agreed that comparative OCP data identifying the Official Meter and listing the average bias for each NTEP meter type should be available for annual review by the Sector. Accordingly, Ms. Brenner, GIPSA, presented data showing the performance of NTEP meters compared to the air oven. This data is based on the last three crop years (2009 - 2011) using calibrations updated for use during the 2012 harvest season. The 2009 - 2011 Grain Moisture Meter (GMM) Phase II comparison graphs may be viewed or downloaded for printing at the following web address:

http://ncwm.net/sites/default/files/meetings/grain_analyzer/2012/12_GMM_Bias.pdf

Ms. Brenner pointed out that the data identified as the “Official Meter” is based on the GAC 2100. The Official Meter data is in blue for all the charts. A randomized assignment of colors was used for the individual manufacturers, so the violet color identified as “Meter 1” on the charts represents a different manufacturer on each chart; “Meter 2” is a different manufacturer on each chart; etc.

Overall, the performance of the meters looked good for all the grains except Long Grain Rough Rice. It had the most variation between meters.

The Sector was reminded that effective September 1, 2012, [Editor’s note: The effective date was subsequently delayed to September 10, 2012.] the DICKEY-john GAC2100 will no longer be the Official Meter for the following four grains: corn, soybeans, sunflower, and sorghum. These four grains will have official calibrations from the two Official Meters, the GAC2500-UGMA, and the AM5200-A. The remaining grains are scheduled to switch to the GAC2500-UGMA, and the AM5200-A for Official Inspection on May1, 2013.

Discussions have been held at GIPSA as to how comparison data might be displayed next year since the Official Meter is changing. Present thinking is that meters will be randomly identified as Meter 1, Meter 2, Meter 3, etc. for each grain. The Official Meters will be included in that random assignment once they have accumulated three years of data.

4. Amend Table S.2.5. of §5.56.(a) in NIST Handbook 44

Source:

NTETC Grain Analyzer Sector

Purpose:

Delete “remotely” from the second paragraph of Category 3 requirements that begins, “When accessed remotely ...” to make it clear that the requirements of Category 3 apply whether accessed manually using the keyboard or accessed by remote means, and add the modified second paragraph of Category 3 requirements to Categories 3a and 3b to make it clear that these requirements apply to all the subcategories of Category 3.

Item Under Consideration:

Table S.2.5. Categories of Device and Methods of Sealing	
Categories of Device	Methods of Sealing
<p>Category 1: No remote configuration capability.</p>	<p>Seal by physical seal or two event counters: one for calibration parameters (000 to 999) and one for configuration parameters (000 to 999). If equipped with event counters, the device must be capable of displaying, or printing through the device or through another on-site device, the contents of the counters.</p>
<p>Category 2: Remote configuration capability, but access is controlled by physical hardware.</p> <p>A device shall clearly indicate that it is in the remote configuration mode and shall not be capable of operating in the measure mode while enabled for remote configuration.</p>	<p>The hardware enabling access for remote communication must be at the device and sealed using a physical seal or two event counters: one for calibration parameters (000 to 999) and one for configuration parameters (000 to 999). If equipped with event counters, the device must be capable of displaying, or printing through the device or through another on-site device, the contents of the counters.</p>
<p>Category 3: Remote configuration capability access may be unlimited or controlled through a software switch (e.g., password).</p> <p>When accessed remotely for the purpose of modifying sealable parameters, the device shall clearly indicate that it is in the configuration mode and shall not be capable of operating in the measuring mode.</p>	<p>An event logger is required in the device; it must include an event counter (000 to 999), the parameter ID, the date and time of the change, and the new value of the parameter (for calibration changes consisting of multiple constants, the calibration version number may be used rather than the calibration constants). A printed copy of the information must be available through the device or through another on-site device. The event logger shall have a capacity to retain records equal to twenty-five (25) times the number of sealable parameters in the device, but not more than 1000 records are required. (Note: Does not require 1000 changes to be stored for each parameter.)</p>
<p>Category 3a: No remote capability, but operator is able to make changes that affect the metrological integrity of the device (e.g., slope, bias, etc.) in normal operation.</p> <p><u>When accessed for the purpose of modifying sealable parameters, the device shall clearly indicate that it is in the configuration mode and shall not be capable of operating in the measuring mode.</u></p>	<p>Same as Category 3</p>
<p>Category 3b: No remote capability, but access to metrological parameters is controlled through a software switch (e.g., password).</p> <p><u>When accessed for the purpose of modifying sealable parameters, the device shall clearly indicate that it is in the configuration mode and shall not be capable of operating in the measuring mode.</u></p>	<p>Same as Category 3</p>

[Nonretroactive as of January 1, 1999]
 [*Nonretroactive as of January 1, 20XX]
 (Amended 1998 **and 201X**)

Note: Zero-setting and test point adjustments are considered to affect metrological characteristics and must be sealed.
 (Added 1993) (Amended 1995 and 1997)

Background/Discussion:

All of the GMMs in Categories 3, 3a, and 3c of Table S.2.5. use an electronic method of sealing, and most of them also offer access to the configuration mode thorough a k eyboard entered password. I n this mode, sealable parameters can also be changed locally through the keyboard. Category 3 of Table S.2.5. currently includes the following requirement:

When accessed remotely for the purpose of modifying sealable parameters, the device shall clearly indicate that it is in the configuration mode and shall not be capable of operating in the measuring mode.

At its 2011 Grain Analyzer Sector Meeting the Sector agreed by consensus that the following changes to Table S.2.5. of §5.56.(a) of NIST Handbook 44 should be forwarded to the S&T Committee for consideration:

- Add a note to Table S.2.5. to recognize the expanded scope of “remote capability”.
- Delete “remotely” from the second paragraph of Category 3 requirements that begins, “When accessed remotely ...” to make it clear that the requirements of Category 3 apply whether accessed manually using the keyboard or accessed by remote means.
- Add the modified second paragraph of Category 3 requirements to Categories 3a and 3b to make it clear that these requirements apply to all the subcategories of Category 3.

At the suggestion of National Institute of Standards Technology (NIST), Office of Weights and Measures (OWM), the Table S.2.5. changes approved by the Sector in 2011 have been separated into two independent items: one dealing with the changes to Category 3 and its subcategories (as shown in Item Under Consideration) and one dealing with the modification of the definition of remote configuration capability appearing in Appendix D of NIST Handbook 44 to recognize the expanded scope of “remote capability.” This independence insures that one item will not hold up the other from consideration.

Contingent upon approval of the Item Under Consideration by NCWM, a number of related changes will be required to both the GMM Chapter and the Near Infrared (NIR) Grain Analyzer Chapter of NCWM Publication 14. These changes are shown in Items 4(a), 4(b), and 4(c) following:

4.a. Proposed Changes to Table S.2.5. in Appendix C of the GMM Chapter of NCWM Publication 14

[Changes shown below are contingent upon acceptance of Item Under Consideration]

Table S.2.5. Categories of Device and Methods of Sealing

Categories of Device	Method of Sealing
<p>Category 1: No remote configuration capability</p>	<p>Seal by physical seal or two event counters: one for calibration parameters (000 to 999) and one for configuration parameters (000 to 999.) If equipped with event counters, the device must be capable of displaying, or printing through the device or through another on-site device, the contents of the counters.</p>
<p>Category 2: Remote configuration capability, but access is controlled by physical hardware.</p> <p>Device shall clearly indicate that it is in the remote configuration mode and shall not be capable of operating in the measure mode while enabled for remote configuration.</p>	<p>The hardware enabling access for remote communication must be at the device and sealed using a physical seal or two event counters; one for calibration parameters (000 to 999) and one for configuration parameters (000 to 999.) If equipped with event counters, the device must be capable of displaying, or printing through the device or through another on-site device, the contents of the counters.</p>

<p>Category 3: Remote configuration capability, access may be unlimited or controlled through a software switch (e.g. password.)</p> <p>When accessed remotely for the purpose of modifying sealable parameters, the device shall clearly indicate that it is in the configuration mode and shall not be capable of operating in the measure mode.</p>	<p>An event logger is required in the device; it must include an event counter (000 to 999), the parameter ID, the date and time of the change and the new value of the parameter (for calibration changes consisting of multiple constants, the calibration version number may be used rather than the calibration constants.) A printed copy of the information must be available through the device or through another on-site device. The event logger shall have a capacity to retain records equal to twenty-five (25) times the number of sealable parameters in the device, but not more than 1000 records are required. (Note: Does not require 1000 changes to be stored for each parameter.)</p>
<p>Category 3a: No remote capability, but operator is able to make changes that affect the metrological integrity of the device (e.g. slope, bias, etc.) in normal operation.</p> <p><u>When accessed for the purpose of modifying sealable parameters, the device shall clearly indicate that it is in the configuration mode and shall not be capable of operating in the measure mode.</u></p>	<p>Device shall clearly indicate that it is in the remote configuration mode and shall not be capable of operating in the measure mode while enabled for remote configuration.</p>
<p>Category 3b: No remote capability, but access to metrological parameters is controlled through a software switch (e.g., password.)</p> <p><u>When accessed for the purpose of modifying sealable parameters, the device shall clearly indicate that it is in the configuration mode and shall not be capable of operating in the measure mode.</u></p>	<p>Remote configuration capability, access may be unlimited or controlled through a software switch (e.g., password.)</p>

[Non-retroactive as of January 1, 1999]

(Amended 1998 **and 201X**)

4.b. Proposed Changes to the Checklist of the GMM chapter of NCWM Publication 14

[Changes shown below are contingent upon acceptance of Item Under Consideration]

For Category 3 Devices

- 4.6.36. If a measurement is in process when the device is accessed **remotely** Yes No N/A for the purpose of modifying sealable parameters, the measurement is either:
- Terminated Before Results can be Displayed or Printed. **OR**
 - Completed Before Entering the Configuration Mode
- 4.6.37. When accessed **remotely** for the purpose of modifying sealable parameters, the device clearly indicates that it is in the configuration mode and is not capable of operating in the measure mode. Yes No N/A

- 4.6.37.1 Describe the method used to seal the device or access the audit trail information:

4.c. Proposed Changes to the Checklist of the NIR Grain Analyzer Chapter of NCWM Publication 14

Near Infrared (NIR) Grain Analyzers use an electronic method of sealing similar to those of GMMs, and most of them also offer access to the configuration mode thorough a keyboard entered password. In this mode, sealable parameters can be changed locally through the keyboard. At the 2011 NTETC Graina Analyzer Sector Meeting, the Sector agreed that contingent upon acceptance of Item Under Consideration the NIR Check List of NCWM Publication 14 should be modified to delete “remotely” from §4 Design of NIR Analyzers, paragraph 4.9.16 as shown below.

[The change shown below is contingent upon acceptance of Item Under Consideration]

- 4.9.16. If a measurement is in process when the device is accessed ~~remotely~~ for the purpose of modifying sealable parameters, the measurement is either:

- 4.9.16.1 Terminated Before Results can be Displayed or Printed. **OR** Yes No N/A
4.9.16.2 Completed before entering the configuration mode Yes No N/A
4.9.16.3 Describe the method used to seal the device or access the audit trail information:

Conclusion:

The Sector agreed by consensus to accept the Item Under Consideration and recommended that a Form 15 be drafted for forwarding this item to the S&T Committee for consideration. M r. Truex, NTEP Administrator, indicated that Items 4.a., 4.b., and 4.c. would automatically be considered by the NTETC upon approval of the Item Under Consideration by the NCWM.

5. Modify the Definition of Remote Configuration Capability Appearing in Appendix D of NIST Handbook 44 to Recognize the Expanded Scope of “Remote Configuration Capability”

Source:

NTETC Grain Analyzer Sector

Purpose:

Table S.2.5. *Categories of Device and Methods of Sealing* that appears in §5.56.(a) of NIST Handbook 44 lists acceptable methods of sealing for various categories of GMMs. When the Sector first recommended adding the table to NIST Handbook 44 at their September 1996 meeting, the concept of making a change to a GMM from a remote site involved information “ ...sent by to the device by modem (or computer).” In 2011 this concept has expanded to include the ability of the measuring device to accept new or revised sealable parameters from a memory chip (e.g., an SD Memory Card that may or may not itself be necessary to the operation of the device), external computer, network, or other device plugged into a mating port (e.g., Universal Serial Bus [USB] port) on the measuring device or connected wirelessly to the measuring device. T he changes proposed in Item Under Consideration expand the scope of “remote configuration capability” to cover instances where the “other device” may be necessary to the operation of the weighing or measuring device or which may be considered a permanent part of that device.

Item Under Consideration:

remote configuration capability. – The ability to adjust a weighing or measuring device or change its sealable parameters from or through some other device that ~~is not~~ **may or may not** itself **be** necessary to the operation

of the weighing or measuring device or ~~is not~~ **may or may not be** a permanent part of that device.[2.20., 2.21., 2.24., 3.30., 3.37., 5.56.(a)]

(Added 1993) (**Amended 20XX**)

Background/Discussion:

Two common types of removable data storage devices are the USB flash drive and the Secure Digital (SD) memory card. A USB flash drive is a data storage device that includes flash memory with an integrated USB interface. USB flash drives are typically removable and rewritable, and physically much smaller than a floppy disk. A SD card is a non-volatile memory card format originally designed for use in portable devices. The SD standard is maintained by the SD Card Association.

Removable digital storage devices can be used in GMMs as either “data transfer” devices which are not necessary to the operation of the GMM or as “data storage devices” which are necessary to the operation of the GMM.

A USB flash drive is most likely to be used as a “data transfer” device. In a typical “data transfer” application, the USB flash drive is first connected to a computer with access to the web. The computer visits the GMM manufacturer’s web site and downloads the latest grain calibrations that are then stored in the USB flash drive. The USB flash drive is removed from the computer and plugged into a USB port on the GMM. The GMM is put into “remote configuration” mode to copy the new grain calibration data into the GMM’s internal memory. When the GMM has been returned to normal operating (measuring) mode the USB flash drive can be removed from the GMM.

Although an SD memory card could also be used as a “data transfer device” it is more likely to be used as a “data storage device”. In a typical “data storage device” application, the SD memory card stores the grain calibrations used on the GMM. The SD memory card must be plugged into an SD memory card connector on a GMM circuit board for the GMM to operate in measuring mode. To install new grain calibrations the GMM must be turned “off” or put into a mode in which the SD memory card can be safely removed. The SD memory card can either be replaced with an SD memory card that has been programmed with the new grain calibrations or the original SD memory card can be re-programmed with the new grain calibrations in much the same way as that described in the preceding paragraph to copy new grain calibrations into a USB flash drive. In either case, the SD memory card containing the new calibrations must be installed in the GMM for the GMM to operate in measuring mode. In that regard, the SD memory card) can be considered a “permanent part” of the GMM in that the GMM cannot operate without it.

Note: In the above example “SD memory card” could be any removable flash memory card such as the Secure Digital Standard-Capacity, the Secure Digital High-Capacity, the Secure Digital eXtended-Capacity, and the Secure Digital Input/Output, which combines input/output functions with data storage. These come in three form factors: the original size, the “mini” size, and the “micro” size. “Memory Stick” is a removable flash memory card format, launched by Sony in 1998, and is also used in general to describe the whole family of Memory Sticks. In addition to the original Memory Stick, this family includes the Memory Stick PRO, the Memory Stick Duo, the Memory Stick PRO Duo, the Memory Stick Micro, and the Memory Stick PRO-HG.

Conclusion:

The Sector agreed by consensus to accept the Item Under Consideration and recommended that a Form 15 be drafted for forwarding this item to the S&T Committee for consideration.

6. Test Weight per Bushel Acceptance and Maintenance Tolerances

Source:

Mr. Jeffrey D. Adkisson, Grain and Feed Association of Illinois

Purpose:

Due to problems cited in the grain and feed industry, review and make any needed changes to the test weight per bushel tolerances in NIST Handbook 44, Section 5.56.(a).

Item Under Consideration:

Re-form a task group to study the test weight per bushel measurement system to include issues with field inspection and grain moisture meters and provide the Sector with recommendations for any needed changes to the test weight per bushel tolerances in NIST Handbook 44, Section 5.56.(a).

Background/Discussion:

This is a carryover from the Sector's 2011 meeting. Mr. Adkisson, Grain and Feed Association of Illinois, cited problems his industry is having regarding Test Weight (TW) per bushel. GMMs that have failed TW during field inspection are sent to the manufacturer for repair. When the meters are returned, the reports indicate that no problems have been found. There are also situations where a meter has failed TW. When the state inspector subsequently tested the elevator's quart kettle it matched the meter, but it didn't match the state inspector's sample. This is particularly frustrating for the country elevators in Illinois that are using the GMM TW only as a screening tool.

At the Sector's August 2011 meeting, a task group was formed to investigate the whole TW system with the goal of defining procedures that would improve TW both for the user and for the inspection system. Past data obtained by the Sector had indicated that the existing tolerances were reasonable. It was felt that increasing TW tolerances would only cover up the problems. What was needed was an investigation of the whole system of calibrating meters, then translating that calibration into the field, and then keeping it that way.

Dr. Charles R. Hurburgh, Jr., Iowa State University, agreed to head the task group. Other TW Task Group members included:

- Mr. Jeffery Adkisson – Grain and Feed Association of Illinois
- Ms. Diane Lee – NIST, OWM
- Ms. Cassie Eigenmann – DICKEY-john Corporation
- Mr. Ivan Hankins – Iowa Department of Agriculture/Weights and Measures
- Mr. Tim Kaeding – Perten Instruments, Inc.
- Mr. Karl Cunningham – Illinois Department of Agriculture

Further action on the issue of tolerances was postponed until the TW Task Group was able to recommend appropriate action.

Earlier this year the TW Task Group developed the following list of Action Items:

- Survey the grain industry as to the frequency of discounting each of the major grains (wheat, corn, and soybeans) for test weight, and within those discounted the frequency of use of the meter test weight versus the cup-bucket test weight.
- Survey the industry for comparative data between meters and an Official GIPSA agency on the same samples.
- Develop a draft procedure for sample selection and pre-qualification

Dr. Hurburgh reported that discounting for low TW was not an issue in either 2010 or 2011. TWs for corn were so high that discounting was not an issue. Within Iowa most grain elevators were using the TW reported by their GMM. Only a few were using the standard quart kettle method. This is likely to change in the 2012 harvest as low TWs are likely to be more common. Also, there may not be as much TW increase in drying as would normally be expected. TW may come up again as a discount factor.

Same sample TW data has not been collected comparing grain elevator GMMs with an Official GIPSA agency. Dr. Hurburgh explained that this information should be relatively easy to obtain, because in almost every case when a train is officially graded the samples are run at the grain elevator first. Since last year's Sector meeting, the rapid acceptance of the new UGMA GMMs as Official Meters for corn, soybeans, sunflowers, and grain sorghum (with the remaining grains scheduled to switch to UGMA GMMs for Official Inspection on May1, 2013), has altered some of the issues. The new technology not only provides a better moisture measurement, but a better TW measurement as well.

The remaining action item that the task group believed was necessary was a procedure for pre-qualifying TW samples as being good predictors for the TW function as well as moisture function. Most States pre-screen moisture samples to get the outliers out of the system. That pre-qualification would have to be expanded if TW is to be actively used to reject meters on the basis of TW.

Dr. Hurburgh recommended that the Sector not adjust TW tolerances at this time, because the system is rapidly changing over to the new technology which is going to result in the improvement in TW readings. The problem should resolve itself as older instruments are retired.

Mr. Karl Cunningham, Illinois Dept of Agriculture, informed the Sector that Illinois's TW rejection rate has gone down in the last two years. He has no problem with TW on the meters in his laboratory and doesn't think the present tolerances are a problem. Many of the field problems may be due to rough handling of the meters during shipping. Mr. Cunningham advises elevators who have to have their devices worked on to take them to the manufacturer's service department themselves if at all possible.

Mr. Tim Kaeding, Perten Instruments, suggested that there might be value in expanding the Phase II OCP grain moisture comparison charts to include TW. Dr. Hurburgh recommended that a TW comparison chart showing the spread of TW measurements for individual meters against the corresponding official quart kettle TW measurements would address the tolerance issue, whereas a bias plot would not. He suggested plotting meter TWs on the x-axis and quart kettle results on the y-axis. A best-fit line could be drawn for each meter.

The Sector agreed that TW comparison charts should be prepared for the three grains which are most likely to be subject to discounts on the basis of TW: Corn and two wheat classes. The wheat classes selected were: Hard Red Winter and Soft Red Winter. Manufacturer approval is required for NTEP Phase II TW performance data to be released for publication even if individual instruments are not identified. The two meter manufacturers present indicated that they would approve the release of this data. Permission would have to be obtained from the other manufacturers.

Conclusion:

Ms. Brenner will send letters, to all GMM manufacturers outlining the way TW data will be displayed for each meter for corn and two classes of wheat. The letters will request formal approval for release of NTEP Phase II TW performance data. Meters will NOT be identified.

The Sector agreed to postpone further action on changing TW tolerances until more information was available.

7. Report on International Organization of Legal Metrology (OIML) TC 17/SC 1 R 59 Moisture Meters for Cereal Grains and Oilseeds

Background/Discussion:

This item was included on the Sector's agenda to provide a summary of the activities of OIML TC 17/SC 1. The Co-Secretariats (China and the United States) are working closely with an International Work Group to revise OIML Recommendation R 59 *Moisture Meters for Cereal Grains and Oilseeds*. The 5 Committee Draft (CD) of OIML R 59, revised to comply with OIML's Guide *Format for OIML Recommendations* and to incorporate tests for the recommended disturbances of OIML Document D 11, *General Requirements for Electronic Measuring Instruments*, was distributed to the Subcommittee in February 2009. Comments to R 59 5 CD were received from 10 countries including the United States. A preliminary R 59 6 CD addressing those comments was prepared for discussion at the September 2010 TC 17/SC 1 meeting in Orlando, Florida. Per discussions at that meeting, Germany submitted suggestions for additional software requirements that will be included in the final draft of R 59 6 CD.

Ms. Diane Lee, NIST, OWM, reported that the preliminary 6 CD will have to be revised to address the comments received at the September 2010 TC 17/S 1 meeting and to incorporate Germany's additional software requirements. The final draft of 6 CD will then be circulated to the TC members for comment and a possible vote. The earliest anticipated date for the final draft of 6 CD is the spring of 2013.

8. Update on Efforts to Establish Recognized Traceability under the International Committee of Weights and Measures (CIPM) Mutual Recognition Agreement (MRA) for Moisture in Grain Measurements

Background/Discussion:

At the 2011 NTETC Grain Analyzer Sector Meeting, Ms. Lee, NIST, OWM, reported that there is a proposal on the international front to do a study of moisture measurement methods with the apparent purpose of establishing a universal standard method “internationally accepted by competent authorities in the field of moisture measurements in grains and cereal.” During the September 2010, TC 17/SC 1 meeting Mr. Jean-Francois Magana, International Bureau of Legal Metrology (BIML), gave an overview of a discussion paper titled, *Efforts to Establish Recognized Traceability Under the International Committee of Weights and Measures (CIPM) Mutual Recognition Arrangement (MRA) for ‘moisture-in-grain’ measurements.* This document discusses National Measurement Institutes having their measurement capabilities internationally recognized for moisture. It also discusses key comparisons for moisture, and the use of *ISO 712, Cereals and cereal products -- Determination of moisture content -- Reference method (not applicable to maize and pulses)*. In November 2011, the United States and China received a notice for a proposal for a new project within TC 17/SC 1 to create a new OIML recommendation to define the measurand “moisture mass fraction in grain” by a globally recognized measurement method. In the United States, NIST, OWM and U.S. Department of Agriculture (USDA), with management from both agencies, held a conference call to discuss technical issues concerning establishing a globally recognized reference method. After which the United States and China responded and elaborated on technical and economic issues. A copy of the response is shown below:

“...On the matter of International Committee of Legal Metrology (CIML) approval of this proposed project, we feel that the draft letter that you have prepared does not provide enough information to CIML Members for them to make an informed decision. We have consulted with members of the United States “mirror” committee, USDA, GIPSA, and they have informed us that studies of the type being proposed here have already been carried out in the 1980s, and so it is questionable whether it makes sense to try and ‘reinvent the wheel’ with this project. The results of the studies have shown that this issue involves not only the technical feasibility of developing an acceptable global measurement method for moisture mass fraction in grains (i.e., defining the measurand), but equally (if not more) importantly involves the economic (and hence political) feasibility of developing and implementing a single global standard. The anticipated global costs associated with making the changes that this project could lead to are staggering, and would quite likely not be acceptable to the stakeholder communities.

Therefore, we believe that the initial letter to the CIML Members should ask not only the technical questions that you have posed (and perhaps others as well), but should also ask what the national agencies and customers in the different Member States have to say about the idea of possibly changing the test method in their country to accommodate a single global standard measurement method. We feel that such information should be obtained (through a formal survey, not in the informal way posed in your draft letter) and then shared with the CIML Members before asking them to vote on approval of this proposal. We would be happy to assist you in the re-drafting of your letter and preparation of the survey.

Elaborating on what we see as the technical issues, it is well recognized that no universal method can be used for all grains and seeds. The main steps of the experimental procedure, for example, pre-drying, grinding, drying time, and temperature, generally differ from one grain type to the next as dictated by physical and chemical composition. Thus, a critical study of the procedure would be required for each grain type. A wide range of grain moisture reference methods are used by major grain exporting and importing countries. Grain moisture reference methods were adopted decades ago and are well established within these countries. Comparison studies have shown that no methods are identical and that differences can be significant between some methods. The extent to which the methods agree will vary by grain type.

Elaborating on what we see as the economic issues, it is challenging to identify economic benefits of moving to an international moisture reference method. Persuasive arguments have been presented that market prices have already adjusted to reflect differences in grain moisture reference results. It is easier, and fairly daunting, to predict costs associated with making a change to grain moisture reference methods for an individual country. It would be necessary to develop new moisture meter calibration coefficients for

each grain type. In some cases, grain drying costs could be increased in order to meet moisture specifications. Perhaps most significantly, price structures would need to be modified...”

This was discussed further at the OIML Presidential Council meeting March 5 - 7, 2012, and it was included in the meeting minutes that there was insufficient evidence that the latest developments described in the NIST, OWM newsletter article would result in an instrument/procedure that could be used as an international standard for moisture mass fraction of grain measurements.

In a conversation with Mr. Patoray, BIML Director, Dr. Erhlich, NIST, OWM was informed that the OIML is no longer pursuing the new project to create an OIML recommendation to define the measurand “moisture mass fraction in grain.”

Subsequently, the United States and China, secretariats of OIML Technical Committee (TC) 17/Technical Subcommittee (SC) 1, received a document from Ms. Stephanie Bell of the National Physical Laboratory in the UK with reference to a proposed research topic to submit to the current call of the European Metrology Research Program (EMRP) to address the need for a more effective metrology infrastructure for measurements of moisture in materials. The United States and China responded including excerpts from the response provided for the OIML Proposal to create a new OIML recommendation to define the measurand “moisture mass fraction in grain”. OIML TC 17/SC 1 was not listed in support of these efforts.

Ms. Diane Lee (NIST, OWM) reported that she is developing an article on grain moisture measurements in the United States that has been reviewed by Dr. Richard Pierce of USDA, GIPSA. This article provides information on U.S. air-oven reference methods to include historical information and a summary of the various test methods used for different grains and types of commodities. This article may also serve to provide the international community with information on the air-oven reference test methods used in the United States.

9. Report on OIML TC 17/SC 8 Protein Measuring Instruments for Cereal Grain and Oil Seeds

Background/Discussion:

This item was included on the Sector’s agenda to provide a summary of the activities of OIML TC 17/SC 8. Subcommittee SC 8 was formed to study the issues and write a working draft document *Measuring Instruments for Protein Determination in Grains*. Australia is the Secretariat for this subcommittee. A TC 17/SC 8 meeting was hosted by NIST, OWM in September 2007 to discuss the 2 CD. Discussions on 2 CD dealt mostly with Maximum Permissible Errors and harmonization of the TC 17/SC 8 Recommendation for protein with the TC 17/SC 1 Recommendation for moisture. The Secretariat distributed a 2 CD of the document in February 2010. A meeting of TC 17/SC 8 was held September 2010 in Orlando, Florida. At the September meeting, comments to the Recommendation on Protein Measuring Instruments for Cereal Grain and Oil Seeds 2 CD were reviewed. It was agreed at this meeting that two instruments will be submitted for OIML type approval.

Ms. Diane Lee (NIST, OWM) reported that the 3 CD of the OIML Recommendation on Protein was distributed to members of the USNWG via e-mail on July 3, 2012. Comments to the 3 CD were requested by September 8, 2012. The 3 CD incorporates the changes to 2 CD that were agreed to at the 2010 TC 17/SC 8 meeting in Orlando, Florida. Changes were also made to the 3 CD to harmonize some section with OIML R 59 and include requirements of OIML D 11. Further discuss is needed to address whether or not all of the OIML D11 requirements that were added to the 3 CD are necessary for protein analyzers. In response to a question, “How many revisions are associated with OIML Recommendations?” Ms. Lee responded that typically, if comments to an OIML Recommendation can be resolved by voice or e-mail, the next version of the Recommendation could be forwarded for to the participating member countries for a Vote.

10. Item 356-1 Printed Ticket User Requirements - Update

Source:

Grain and Feed Association of Illinois (2012)

Purpose:

Change the mandatory printing of tickets from grain moisture meters to an “on demand at the time of transaction” printing and remove the requirement of printing the calibration version identification. Note that the S&T Committee did not agree with proposed removal of the requirement to print the calibration version identification; this position is reflected in the version of the proposal currently under consideration by the Committee.

Item Under Consideration:

Amend NIST Handbook 44, Grain Moisture Meter Code 5.56.(a) as follows:

UR.3.4. Printed Tickets.

- (b) The customer shall be given a printed ticket **at the time of the transaction or as otherwise specified by the customer.** The printed ticket shall include the date, grain type, grain moisture results, and test weight per bushel, and calibration version identification. The ticket **information** shall be generated by the grain moisture meter system.

(Amended 1993, 1995, ~~and~~ 2003, and 20XX)

Background:

According to the submitter, the user requirement to provide a printed ticket for every single load is unrealistic in the country elevator industry. Traffic patterns at country elevators do not lend themselves to providing a printed ticket to all customers and customers really don't want them. As the speed and capacity increases in the industry, outbound scales are being located at a distance from the inbound scale and the scale house where the moisture tester is located to alleviate traffic bottlenecks. When the outbound scale is located away from where the ticket is printed, the truck driver must circle back around to pick up the ticket, thus, causing logistical problems. In addition, since meters are sealed, inspected and required to have the correct calibration, there is no need for the calibration version identification to be printed on the ticket. Also, most customers are not going to know if it is the correct calibration version identification or not. There have been problems getting the information from the grain moisture meter to the grain accounting system – especially the calibration version identification. Some grain accounting systems have to be “hard coded” for calibration version identification which must be changed whenever the calibration changes. The change will be at an added cost for the industry.

When a consumer pays at a gas pump, they have the option of a receipt on demand at the time of transaction or not receiving a receipt. There would be a cost savings to moisture meter users as they would save on paper and filing space, and in the situation where the calibration version identification is “hard coded,” there will be a cost savings of the expense to have the grain accounting software provider make those changes.

Since moisture meters are capable of printing the ticket, some would argue that they should just go ahead and print them and provide them to the customer. In addition, the requirement does not say when the ticket shall be given to the customer; thus, the printed tickets could be saved for weeks, months, or even years in case the customer had a concern at some point. Printing the calibration version identification ensures the correct calibration is being used.

The submitter proposed amendments to paragraph UR.3.4. Printed Tickets as follows:

UR.3.4. Printed Tickets.

- (b) The customer shall be given a printed ticket on **demand at the time of the transaction** showing the date, grain type, grain moisture results, **and** test weight per bushel, ~~and calibration version identification~~. The ticket **information** shall be generated by the grain moisture meter system.

(Amended 1993, 1995, ~~and~~ 2003, and 20XX)

At the 2011 Central Weights and Measures Association (CWMA) Interim Meeting some jurisdictions opposed the proposal citing that it is a fundamental element of a point of sale transaction that there is either a witness to the transaction or that a receipt is made available. Others supported the item and recognized that many customers refuse to take the printed tickets. The CWMA believes that the calibration version identification is not necessary on the ticket since most jurisdictions are already verifying the calibrations version when the device is inspected. This proposal is not eliminating the opportunity for the seller to obtain a printed ticket. The CWMA forwarded the item to NCWM, recommending it as a Voting Item.

At the 2011 Western Weights and Measures Association (WWMA) Annual Meeting, the Committee heard no comments on this item. The WWMA amended the proposal to make the language consistent with other codes such as 3.32. LPG and Anhydrous Ammonia Liquid-Measuring Devices Code paragraph UR.2.6. Ticket Printer: Customer Tickets. The WWMA forwarded the modified version below to NCWM, recommending it as a Voting Item.

UR.3.4. Printed Tickets.

- (b) The customer shall be given a printed ticket ~~showing at the time of the transaction or as otherwise specified by the customer. The printed ticket shall include~~ the date, grain type, grain moisture results, and test weight per bushel, ~~and calibration version identification~~. The ticket information shall be generated by the grain moisture meter system.

(Amended 1993, 1995, ~~and~~ 2003, and 20XX)

At the 2011 Northeastern Weights and Measures Association (NEWMA) Interim Meeting there were no comments. Deferring to the expertise of the NTETC Grain Analyzer Sector, NEWMA forwarded the item to NCWM, recommending it as a Developing Item.

At the 2011 Southern Weights and Measures Association (SWMA) Annual Meeting, Ms. Butcher, NIST Technical Advisor, noted that the proposed language submitted was slightly different from that discussed by the NTETC Grain Analyzer Sector and provided a summary corresponding to this item prepared by Ms. Lee, Grain Analyzer Sector Technical Advisor. Ms. Butcher also pointed out that WWMA proposed alternate language that is consistent with printed tickets requirements in other codes. The SWMA agreed that the customer should be given the option of receiving a printed ticket from a transaction and that the proposed changes would clarify the responsibility of the device user. The SWMA preferred the option forwarded by WWMA since it mirrors existing language in other NIST Handbook 44 codes. The SWMA forwarded the item to NCWM, recommending it as a Voting Item as revised by WWMA.

At the 2012 NCWM Interim Meeting, the S&T Committee received comments in support of the alternative language submitted by the WWMA. NIST, OWM reported that the proposed language submitted to the regional weights and measures associations was different from that agreed to by the Grain Analyzer Sector at its August 2011 meeting. The Grain Analyzer Sector had specifically opposed deleting the phrase “calibration version identification.” NIST, OWM also noted that not all grain moisture meters are Category 3 devices; consequently, calibration version identification information is a critical component on the printed receipt to reconstruct the basis for a sale and help officials to resolve complaints.

The Committee agreed that the version proposed by WWMA and SWMA was preferable since it mirrors similar language in other NIST Handbook 44 Codes. The Committee also agreed that, given the Grain Analyzer Sector’s opposition to deleting the reference to “calibration version identification,” this phrase should be retained in the paragraph. The Committee presented an amended version of the proposal. The Committee recognized that the regional associations were not aware of the Sector’s position on the proposed deletion of the reference to the calibration version and that the submitter has not had an opportunity to review the significant changes from the original version. The 2012 S&T Committee designated this item as an Informational Item to allow additional opportunity for input.

At the Sector’s August 2012 meeting, one member suggested that the phrase “or as otherwise specified by the customer” be modified to read “or as agreed to by the customer.” Customers are not going to proactively specify

how elevator record keeping systems are put together, but they can agree that this information comes on a settlement sheet. A contract for the sale of grain at some future date with XYZ Grain contains a phrase that the seller agrees to XYZ Grain's various transaction policies. By signing the contract, the seller agrees to accept settlement sheet information via a web listing that can be accessed with a computer or possibly using a smart phone. The seller is not "specifying" how he wants to receive the "ticket" information, he is just "agreeing" to receive it in a different manner.

The wording proposed by the Sector in 2011, "A printed ticket shall be made available to the customer upon request at the time of transaction..." did not require the customer to do anything if he didn't want a ticket, but it did require him to ask for one if he wanted one. The wording in the Item under Consideration required the customer to say, "I don't want a ticket" if a ticket wasn't wanted. If he said nothing, he would be given a ticket (or offered one).

Other Sector members felt that the wording of the Item under Consideration allowed flexibility, and most were in favor of accepting the Item under Consideration. An attempt to obtain a consensus on the S&T Committee's proposal was unsuccessful due to one jurisdiction's belief that ... "a ticket is given to the customer no matter what."

There was further discussion on whether the wording in the Item under Consideration, "... at the time of the transaction or as otherwise specified by the customer" means that the customer gets a ticket at the time of transaction or at a later specified time. Some believed that "as otherwise specified by the customer" could mean "never" or "in another form." Sector Chairman, Ms. Cassie Eigenmann, DICKEY-john, Corp., reminded the Sector that the reason Illinois Grain & Feed Association submitted the request for change was because they did not want to have to print a ticket at the time of transaction unless the customer requested one at the time of transaction.

It was pointed out that unless a ticket is printed by the GMM before the grain sample is "dumped" from the GMM it may not be possible for the GMM to print a ticket for that transaction. The information, however, could reside in the memory of the elevator's grain transaction system and could be printed in another form for example, on a settlement sheet that is sent (or transmitted) to the seller later. Further discussion suggested that the S&T proposed wording could be interpreted to mean that elevators that captured GMM information in their grain transaction system at the time of transaction would not have to supply a GMM printed ticket at time of transaction unless requested by the customer at time of transaction. If the elevator is using a GMM that is equipped to record and that was put into service **before** January 1, 1998, the elevator would be required to give the customer a printed ticket at the time of transaction (need print only percent moisture content and grain selected).

Conclusion:

After further discussion a formal vote was taken to accept the Item Under Consideration as shown above. The vote was nine in favor to one opposed. The opposing vote was based on the implied need to give every customer a printed ticket.

11. Update on Proficiency Testing

Source:

Dr. Hurburgh, Iowa State University

Purpose:

Develop an air-oven proficiency testing program to ensure state laboratory and manufacturers air-oven measurements are traceable to the official USDA, GIPSA air-oven measurements.

Item Under Consideration:

Create an ongoing air-oven proficiency testing program for states maintaining a grain moisture laboratory and GMM manufacturers.

Background/Discussion:

At the 2009 NTETC Grain Analyzer Sector Meeting, Dr. Hurburgh, Iowa State University, urged the representatives from the American Oil Chemists Society (AOCS) to prepare a proposal so that the collaborative (air-oven) study

could be conducted on an on-going basis rather than on an *ad hoc* basis. He cautioned that the proposal would have to include corn and wheat as well as soybeans.

At the 2011 NTETC Grain Analyzer Sector Meeting, Ms. Johnson, AOCS, proposed an air-oven/GMM proficiency testing series designed specifically to address the needs of GMM manufacturers and states maintaining a grain moisture laboratory. AOCS would administer the program, oversee distribution of samples, compile results, perform statistical analysis of results, and distribute a report to participants. AOCS does not collect the samples. This is subcontracted to suitable providers. AOCS does not have laboratories. Since GIPSA/FGIS is a certified laboratory already participating in the AOCS Soybean Quality Traits program, GIPSA air-oven results could be reported for comparison.

At the Sector's August 2012 meeting, the Sector learned that Ms. Christine Atkinson will be taking over the Proficiency Testing program for states and interested manufacturers formerly headed by Ms. Amy Johnson. Ms. Atkinson verified that participant's cost will remain \$100 per year. The Sector reiterated that the program should focus solely on the standard FGIS air-oven method. Instrument results will not be reported. Participants' air-oven results will be compared against GIPSA's standard FGIS air-oven results. In response to Ms. Atkinson's question about scheduling, the Sector was in general agreement that samples should ship after harvest, preferably between mid-January and mid-February with participants' results due 30 days after the shipping date.

Conclusion:

In summary, the Sector agreed upon the following Program Details:

- Samples – Soybeans 2, Corn 2, Hard Red Winter Wheat 2
- Cost to Participants – \$100.00/year
- Schedule:
 - Samples (6) ship between January 15 and February 15.
 - Samples must be tested within 5 business days of receipt with results due 30 days after the shipping date.
- Reports to be posted on www.SoybeanQualityTraits.org by 1 May.
- Only the GIPSA oven results will be identified. Individual manufacturer's and State participant's oven results will be assigned an identifier known only to the manufacturer or State participant. Instrument results will not be reported.
- Detailed Participant Instructions will be provided to each participant.

12. NCWM Publication 14, NTEP Administrative Policy Changes

Source:
NTEP

Background/Discussion:

NCWM is working on revisions to NCWM Publication 14, *Administrative Policy*, to put it in a more logical order and more understandable form. The purpose is not to change the intent of the publication, but to realign and clarify sections as necessary. Sectors, Committees, and the NTEP laboratories are asked to review the revised section, NTEP *Administrative Policy* and provide feedback. An electronic copy of the document was distributed by NCWM to all who registered to attend the NTETC Grain Analyzer Sector meeting in August.

Conclusion:

No comments were offered at the August 2012 Sector meeting.

[Editor's Note: On September 14, 2012, Mr. Don Onwiler, NTEP Executive Director, sent an e-mail message to GA Sector meeting attendees alerting them that the *Administrative Policy* document distributed for the Sector's meeting was not the most up-to-date version. The most recent copy is now posted to the GA Sector "meeting documents" page on the NCWM web site. It can be accessed at: <http://www.ncwm.net/content/grain-analyzer-docs>. Mr. Onwiler welcomes comments for the next two months.]

13. Next Sector Meeting

Mr. Jim Truex, NTEP Administrator, suggested that the Sector consider using some form of web conferencing if a meeting of only four or five hours would be required. At that time, it was difficult to determine what the outcome would be for the issues the Sector was forwarding to the S&T Committee. Should it be necessary to hold a physical meeting, the Sector agreed to the following tentative location and dates:

Dates: Wednesday, August 21 and Thursday, August 22, 2012
Location: Chase Suites by Woodfin at KCI in Kansas City, Missouri (if available)

14. Review of Form 15s

Background/Discussion:

At the end of the first day of the Sector's August 2012 meeting, the Co-Technical Advisors agreed to complete the Form 15s that would be required to move Agenda Items 4, 5, and 10 forward. The following morning three completed Form 15s were presented for the Sector's review and approval:

1. Amend Table S.2.5. of §5.56.(a) in NIST Handbook 44 ([see GA Agenda Item 4.](#))
2. Modify Definition of Remote Configuration ([see GA Agenda Item 5.](#))
3. S&T Committee Item 356-1 Printed Ticket User Requirements ([See GA Agenda Item 10.](#))

Conclusion:

The Sector accepted Form15s "one" and "two" by consensus and "three" by a vote of 9 in favor to 1 opposed. As before, the opposing vote was based on the implied need to give every customer a printed ticket.

15. Update on the New Meter Technology

Background/Discussion:

The Sector invited Dr. David Funk, Deputy Director and Chief Scientist, GIPSA/FGIS Technology and Science Division, to update the Sector on the new meter technology. Following is a summary of his presentation:

History of Official Moisture Meter Approvals

- 1937 – Tag-Heppenstall
- 1960 – Motomco Model 919
- 1998 – DICKEY-john GAC 2100
- April 11, 2012 – First UGMA-Compatible moisture meters approved
 - DICKEY-john GAC 2500UGMA
 - Perten AM-5200-A

What is GIPSA's Unified Grain Moisture Algorithm (UGMA)?

- Very accurate dielectric-type moisture method
- Higher measurement frequency (about 150 MHz)
- Based on a defined physical parameter–Dielectric Constant
- Excellent density correction (Landau-Lifshitz, Looyenga Density Correction with LLL Exponent = 3)
- Three "unifying parameters" per grain group (Slope, Offset, and Translation Unifying Parameters)
- A single calibration "curve" for all grain types (a 5th-Order Polynomial)
- Precise, wide-range temperature correction
- Calibrated to GIPSA's standard AIR Oven method
- "Open" – Available to any manufacturer

Why Change to UGMA?

- Improved accuracy for all grain types

- Improved accuracy of UGMA
- Improved year-to-year calibration stability
- Drastically improved accuracy on high and low test weight corn
- Wider sample temperature ranges (allows measuring frozen grain)
- “Green” grain effects reduced (moisture “rebound” significantly reduced)
- Easier calibration development

GIPSA’s Basic Definition of Equivalency

- Same Technology
- Very close agreement among types as well as units of a type
- Same calibrations and standardization processes

UGMA – Compatibility Criteria

- NTEP Certification
- Documented and stable production processes
- Measurement frequency – 148.5 MHz to 150.5 MHz
- Standardize Test cell design
- Standardized loading method
- Standardize measurements
 - Sample dielectric constant
 - Sample mass
 - Sample temperature
- Tight tolerances specified for individual subsystems as well as for moisture results
- Must use specified mathematics
- Units’ agreement with FGIS Master system must meet tolerances in FGIS Regulations
 - ± 0.05 % M for Headquarters Standard units
 - ± 0.15 % M for other Official units(where “M” is the mean difference on medium-moisture HRWW)
- All UGMA-Compatible models must be able to use the same check testing process.
- A simple check testing process must ensure performance on all grains over full moisture ranges.
- Instruments must provide for efficient means of entering calibrations.
- Instruments must provide standardized output data stream for printing or networking.

Anticipated Moisture Changes with Transition to UGMA

- GAC2100 and new UGMA-based meters are all calibrated to agree with GIPSA’s air oven method as closely as possible.
- Do not expect significant average differences between GAC2100 and new UGMA-based meters – **except:**
- Low test weight corn moisture values will generally **increase:**
 - GAC2100 reads lower than UGMA by 0.2 % per pound per bushel below 57 lb/bu.
- High test weight corn moisture values will generally **decrease:**
 - GAC2100 reads higher than UGMA by 0.2 % per pound per bushel above 57 lb/bu.

Implications on Field-testing UGMA Meters

- Better to test with another UGMA meter
- Alternatively, test with one sample of grain
- Test weight will make a difference in the moisture result of UGMA meters (May need to verify that UGMA meter is measuring mass correctly.)

Implications for the Next Five Years

- There may be profound changes. Do we need NTEP phase 2?
- Reduction in the number of grain samples that are being collected but will not need to collect as many samples for the official meters which are UGMA meters now.

More information can be found at the GIPSA web page on UGMA moisture meter implementation:
<http://www.gipsa.usda.gov/fgis/equipment.html>

THIS PAGE INTENTIONALLY LEFT BLANK

Appendix D

National Type Evaluation Technical Committee (NTETC) Measuring Sector Annual Meeting Summary

October 5 - 6, 2012
Louisville, Kentucky

INTRODUCTION

The charge of the NTETC Measuring Sector (herein after referred to as “Sector”) is to provide appropriate type evaluation criteria based on specifications, tolerances and technical requirements of NIST Handbook 44, *Specifications, Tolerances, and Other Technical Requirements for Weighing and Measuring Devices*, Sections 1.10. General Code and all portions of Section 3 including codes for Liquid Measuring Devices, Vehicle Tanks Meters, Liquid Petroleum Gas and Anhydrous Ammonia Measuring Devices, Cryogenic Liquid Measuring Devices, Milk Meters, Water Meters, Mass Flow Meters, and Carbon Dioxide Liquid Measuring Devices. The Sector’s recommendations are presented to the National Type Evaluation Program (NTEP) Committee each January for approval and inclusion in NCWM Publication 14, *Technical Policy, Checklists, and Test Procedures* for national type evaluation.

The Sector is also called upon occasionally for technical expertise in addressing difficult NIST Handbook 44 issues on the agenda of National Conference on Weights and Measures (NCWM) Specifications and Tolerances (S&T) Committee. Sector membership includes industry, NTEP laboratory representatives, technical advisors, and the NTEP Administrator. Meetings are held annually, or as needed and are open to all NCWM members and other registered parties.

Suggested revisions are shown in **bold face print** by ~~striking-out~~ information to be deleted and underlining information to be added. Requirements that are proposed to be nonretroactive are printed in ***bold-faced italics***.

Note: It is policy to use metric units of measurement in publications; however, recommendations received by NCWM technical committees and regional weights and measures associations have been printed in this publication as submitted. Therefore, the report may contain references to inch-pound units.

Table A
Table of Contents

Title of Content	NTEP Appendix D – Page
INTRODUCTION	1
CARRY-OVER ITEMS:	3
1. Add Testing Criteria to NTEP Policy U “Evaluating Electronic Indicators Submitted Separate from a Measuring Element”.....	3
2. Product Families Table - Include Water on Existing NTEP CC’s.....	5
3. Product Families Table – Change Test Requirements for Turbine Meters from Test A to Test E.....	7
4. Product Families Table – Consolidate Product Categories for PD and Turbine Meters	8
NEW ITEMS:	10
5. Pictograms for “Setup or Configuration Mode Enabled”	10
6. Utility Water Meter Repeatability Tolerances.....	12
7. Water Meters Permanence Flow Rates.....	14

NTEP Committee 2013 Final Report
 Appendix D – NTETC 2012 Measuring Sector Meeting Summary

8. Clarify Scope of Technical Policy R (VTM and Stationary) - Applicability to both Meters and Registers	16
9. Product Families Table - Correct the Units for the Turbine Meter’s Critical Parameter of Kinematic Viscosity to Centistokes (cSt) in the Product Families Table	17
10. Post-Delivery Discounts and Electronic Receipts	18
11. NCWM Pub 14, NTEP Administrative Policy Revision	20
ADDITIONAL ITEMS AS TIME ALLOWS:	20
12. Windshield Washer Fluid Vending Units	21
13. Hot Water Meters	22
14. Section 3.31. Vehicle-Tank Meters; Paragraph T.4. Product Depletion Test (<i>S&T Carryover Agenda Item</i>)	23
NEXT MEETING:	27

APPENDICES:

A — Draft Checklist for Testing Electronic Digital Indicators with Simulated Pulses (Agenda Item 1)	D / A1
B — Draft Measuring Element vs. Register Evaluation Criteria (Technical Policy T) (Agenda Item 1)	D / B1
C — 1991 Product Families Table Proposal - Liquid Controls (Agenda Items 2-4)	D / C1
D — 1991 PD Meters TP 101D - Smith Meter Inc. (Agenda Items 2-4)	D / D1
E — Technical Policy C-Product Families Table-Centistoke Correction (Agenda Item 9)	D / E1
F — Post-Delivery Discount Revisions-Publication 14 Liquid Measuring Devices (Agenda Item 10)	D / F1
G — Post-Delivery Discount Revisions-Publication 14 ECR Interfaced with RMFD (Agenda Item 10)	D / G1
H — Action Items Table	D / H1
I — List of Attendees at 2012 Measuring Sector Meeting	D / I1

Table B
Glossary of Acronyms and Terms

Acronym	Term	Acronym	Term
CC	Certificate of Conformance	NTEP	National Type Evaluation Program
DMS	Division of Measurement Standards	NTETC	National Type Evaluation Technical Committee
ECR	Electronic Cash Register	OIML	International Organization of Legal Metrology
GPM	Gallons Per Minute	OWM	Office of Weights and Measures (NIST)
HB 44	NIST Handbook 44 <i>Specifications, Tolerances, and Other Technical Requirements for Weighing and Measuring Devices</i>	PD	Positive Displacement
L&R	Laws and Regulations	Pub 14	NCWM Publication 14
LMD	Liquid Measuring Devices	RMFD	Retail Motor-Fuel Dispenser
mA	milliamp	SI	International System of Units
MMA	Meter Manufacturer’s Association	VTM	Vehicle Tank Meter
NCWM	National Conference on Weights and Measures	W&M	Weights and Measures
NIST	National Institute of Standards and Technology		

This glossary is meant to assist the reader in the identification of acronyms used in this agenda and does not imply that these terms are used solely to identify these organizations or technical topics.

CARRY-OVER ITEMS:

1. Add Testing Criteria to NTEP Policy U “Evaluating Electronic Indicators Submitted Separate from a Measuring Element”

Source:
 California NTEP Lab

Background:
 At its 2007 meeting, the Measuring Sector heard that Technical Policy U in Pub 14 allows for testing an indicator separate from a measuring element. However, specific test criteria had not been developed for this practice. The Sector heard a recommendation to develop and add specific criteria for testing an indicator separate from a measuring element.

From 2007 to 2010, the California NTEP Laboratory worked to develop a checklist, but had received limited input on the drafts. At the 2009 Sector meeting, Mr. Dan Reiswig (CA DMS) provided an update to the Sector on the progress of the project. He presented a draft checklist, noting that the checklist follows the general format of NCWM Publication 14 and the main test procedures are at the end of the document. At the 2010 Sector meeting, Mr. Reiswig presented a list of the areas of the checklist that specifically needed further attention and review. Appendices A and B, submitted by Mr. Reiswig, contain the draft checklist and proposed revisions to Technical Policy T.

At the conclusion of its 2011 meeting:

The Sector agreed that additional work is needed to finalize the checklist. Mr. Rich Miller (FMC) volunteered to serve as Chair of the Work Group. Sector Technical Advisor, Mr. Marc Buttler (NIST OWM), will assist as needed and monitor progress of work.

Discussion:

Mr. Miller reported that a new electronic indicating device is very close to being released by FMC. FMC would like to use the normal NTEP evaluation of this device as an opportunity to help complete the new checklist. Results from a “bench test trial” using the draft checklist will be used by the Work Group and brought back to the Sector.

Mr. Miller understands that, once the checklist has been adopted in NCWM Publication 14, an indicator will not require a permanence test beyond the initial laboratory bench testing for approval in stationary applications because there is no wear on an electronic indicator that results from product flow as there is with a measuring element. However, since the checklist has not yet been completed by the Sector, Mr. Miller is planning for the device to undergo both the bench test trial of the new checklist and a full field evaluation, including a full permanence test on a vehicle.

Mr. Miller expects the new FMC device will be submitted for NTEP evaluation for a vehicle-mounted approval by the end of 2012. This device receives a pulse input representing the measured quantity. Serial communication from the measuring device is not within the scope of the proposed evaluation.

It was proposed by FMC that the bench testing could be conducted at the ISO 17025 accredited FMC Lab in Erie, Pennsylvania, in December. The truck on which the device will be mounted for field-testing and permanence evaluation is also located in Erie.

Final details regarding assignment of the project to one of the NTEP labs and timing will need to be decided at the time the device is submitted. However, because all the work on the checklist to date has originated from California, the Sector, with the concurrence of the NTEP Director, agreed that the CA DMS NTEP Lab would be the preferred lab for the trial as long as there are no scheduling issues.

Decision:

The Sector agreed to carry the item over to the Sector’s next meeting based on the recommendation from the Work Group to allow for completion and trial of the checklist. Mr. Jack Kiefert (Honeywell Enraf) has volunteered to join the group.

Work Group members as revised at the Sector’s 2012 meeting are listed below:

Electronic Indicators Checklist Work Group	
Chair:	Rich Miller, FMC
Members:	Dmitri Karimov, Liquid Controls
	Mike Keilty, Endress and Hauser
	Jack Kiefert, Honeywell Enraf
Review & Comment:	Mike Frailer, Maryland Weights and Measures
	Allen Katalinic, North Carolina Division of Measurement Services
Technical Advisor:	Marc Buttler, NIST, OWM, Office of Weights and Measures

Appendices A and B to this summary contain the draft checklist and proposed revisions to Technical Policy T. submitted by Mr. Reiswig. The Work Group was asked to address the highlighted sections in the draft checklist. The Work Group was also asked to address the five points below and then submit the finished checklist to the two lab representatives listed above for review and comment.

- 1) **A minimum of 10 000 pulses must be collected. To ensure that there will be a change in the displayed indication for each pulse received, the electronic indication should be scaled such that the value of the smallest indicated division should equate to less than or equal to the value associated with one input pulse.**
- 2) **It is important to validate whether ± 1 pulse is an appropriate tolerance, taking into consideration applicable OIML requirements.**
- 3) **The number of different temperature inputs and API gravity values that would need to be tested to adequately verify the temperature compensation function of an electronic indicator must be determined. It has been proposed that spot-checking of three random tables at three different temperatures would be adequate to verify that an indicator's temperature compensation feature is functioning properly.**
- 4) **A step for checking multipoint calibration along with associated guidance should be developed and added to the checklist. This guidance should emphasize the necessity of working with the manufacturer of each device in order to set up tests to properly check multipoint calibration using simulated pulses.**
- 5) **Addressing various different input signal formats including pulses, analog, and digital communication will be challenging. A analog (4-20 mA) input devices are to be excluded from the scope at this time. The Work Group is asked to address pulse (frequency) signals in the final version of the checklist and is asked to consider whether or not to also include digital communications.**

2. Product Families Table - Include Water on Existing NTEP CC's

Source:

Dmitri Karimov, Liquid Controls

Background:

Flow meters are approved to very tight tolerances on aggressive liquids such as acids, alcohols, glycol/water mixtures, and liquid fertilizers. Many of these liquids, including glycol/water mixtures and some liquid fertilizers, are water-based. Water is a less aggressive fluid and has a wider NIST Handbook 44 tolerance than these liquids.

A note at the end of the Product Families Table in NCWM Publication 14 allows water to be used as a test product in the "Fuels, Lubricants, and Industrial and Food-grade Liquid Oils" product family.

Despite these points, NCWM Publication 14 requires separate tests with water in order to add water to an existing PD or turbine meter NTEP CC which was issued based on tests with other products in the "Fuels, Lubricants, and Industrial and Food-grade Liquid Oils" product family.

At the conclusion of its 2011 meeting: The Sector voted on a proposal to add a note to the end of the Product Families Table that would apply to all technologies as follows:

The water family (in its entirety or partially – as determined by NTEP) can be included on an NTEP CC based on an approved product or range of products with similar metrological characteristics (specific gravity, conductivity, and viscosity – as applicable to the relevant meter technology) unless materials constituting the measuring element are known to deteriorate in contact with water.

The proposal and the results of the vote shown below were forwarded to the NTEP Committee.

In favor: 9
Opposed: 3
Abstained: 1

Note: Two of the three labs were opposed to the item.

On January 21, 2012, the NTEP Committee returned this item to the Sector for further consideration, noting that because the majority of the NTEP labs did not concur with the proposal, the conclusion did not represent a consensus among all segments of the membership.

Discussion:

At its 2012 meeting, the Sector reviewed and discussed each of the five points that were noted as unresolved issues in the 2011 summary:

Issue 1: The proposal to leave the decision of whether to add water to a CC without any additional testing up to the judgment of the NTEP labs on a case-by-case basis caused concern among some Sector members. The labs and some manufacturers were concerned that such ambiguity in NTEP policy could lead to unintentional inconsistency and less predictable outcomes during type evaluations.

The Sector discussed how, in order to replace testing with their judgment alone as the means of verifying suitability and metrological integrity of a meter with a new product family, the NTEP labs would need to invest in developing material compatibility expertise that would extend beyond what is justified by their primary mission.

Issue 2: A concern was raised about the application of the LMD Code and the Water Meters Code in NIST Handbook 44. Paragraph A.2.(d) of the LMD Code specifically excludes water meters. This exclusion requires a meter that already has a CC under the LMD Code to meet a potentially different set of requirements found in the Water Meters Code in order to add water to the CC. For example, a 3” size PD meter that is already approved under the LMD Code with a maximum discharge rate of 300 gpm would be required by paragraph S.4.4.1. in the LMD Code (Section 3.30.) to have a minimum discharge rate not to exceed 20 % of the marked maximum discharge rate, or 60 gpm. Therefore, the meter could be approved for use in applications other than water with a flow rate range from 60 gpm to 300 gpm. However, to comply with paragraph N.4.2. “Special Tests” in the Water Meters Code (Section 3.36.), the device would need to be able to pass special tests at 20 gpm, as shown in Table N.4.2.a.; this flow rate is three times smaller than what would normally be permitted by the LMD Code to be the smallest minimum rated discharge rate.

The Sector discussed emerging commercial water-measuring applications, such as Water-For-Injection (WFI), where the value of the water has been increased by industrial processes and larger quantities are measured. In these applications, a device other than a traditional utility water meter is generally preferred. With the emergence of new water-measuring applications, manufacturers question whether the requirements for traditional utility and batching applications, especially those that restrict flow rate ranges by meter size, should still apply to all applications that measure water of every type. It is possible that paragraph G-A.3. “Special and Unclassified Equipment” in NIST Handbook 44 may apply to some emerging applications that do not clearly fit the standard utility and batching applications that the Water Meters Code is intended to address. The Sector noted that there are already exceptions in the Water Meters Code that exclude mass flow meters and meters mounted on vehicle tanks. In both of these cases, meters must meet more stringent requirements, but are afforded greater flexibility of flow rate ranges than those that are allowed in the Water Meters Code.

More information is needed about the specific parameters of emerging water-measuring applications that do not fit clearly into the range of applications that are intended to be addressed by the Water Meters Code in order to develop a proposal to update NIST Handbook 44 for these applications. It is not yet clear from what is currently known whether it would be more appropriate to expand the scope of the Water Meters Code to address new applications or to modify the exception to water meters in the LMD Code to allow for certain types of water-measuring applications. In either case, the nature of the new applications must be well understood in order to justify a proposal to change NIST Handbook 44.

Issue 3: The Sector understands that any amount of testing will require some resources, and an effort is made to avoid policies that are not essential to assuring metrological integrity that might impose unreasonable burdens on manufacturers. However, several manufacturers stated that they often test on water and did not understand how testing with water could be viewed as an unreasonable burden.

The Sector discussed whether it would create a burden for some devices to require testing with water if the device is difficult to test on water because of questionable material compatibility. The Sector concluded that testing with water is even more important for devices which are marginally compatible with water or for which the compatibility with water is not well understood because the device was not originally intended to measure water.

Issue 4: There were concerns raised that water has been grouped separately in the product families table in the past for a reason, and that different types of water can affect measuring devices differently.

It was proposed to revise the Product Families Table, but a detailed proposal has not yet been developed.

Issue 5: A concern was raised that the word “similar” as used in the proposed language needed to be defined in more detail. During the 2011 Sector meeting, a definition for “similar” was proposed by one manufacturer as describing a group of two or more fluids that share the same value of the single critical property that applies to the device technology of concern (i.e., dynamic viscosity for PD meters, kinematic viscosity for turbine meters, specific gravity for mass flow meters, and conductivity for magnetic flow meters). This definition of similar fluids did not offer any explanation as to the reason that there are multiple product families in the Product Families Table which are similar as far as the critical property, but nevertheless have been defined as separate families ever since the adoption of the original version of the table.

The Sector agreed that some of the different product families were created to match meters made with different materials of construction. However, no one could say with certainty whether or not there are additional fluid product properties beyond the critical property for the device in question that affect the metrological integrity and durability of different measuring device types.

The submitter proposed withdrawing the item in recognition that there is no consensus support for the item as it is currently presented. Mr. Dmitri Karimov (Liquid Controls) plans to develop and submit a new item that will replace the current Agenda Items 2, 3, and 4.

Decision: The Sector agreed to Withdraw the item and anticipates Mr. Karimov will introduce a new item that combines Items 2, 3, and 4 from the 2012 Sector Agenda and which includes a detailed draft in the format of the Product Families Table.

3. Product Families Table – Change Test Requirements for Turbine Meters from Test A to Test E

Source:

Dmitri Karimov, Liquid Controls

Background:

In the Product Families Table of NCWM Publication 14, turbine meters require testing on individual products with some exceptions. This approach, which was appropriate many years ago when turbine meters were first entering the custody transfer arena, has become outdated. Turbine meters have been tested extensively by NTEP. The submitter contends that turbine meters need to at least have product tests match those of PD meters because turbine meter influence factors are similar to those of PD meters.

Discussion:

Mr. Karimov suggested Withdrawing the item until such time as a more detailed proposal that includes a draft of the changes to the Product Families Table can be completed. The Sector agreed that much of the discussion pertaining to Agenda Item 2 also applied to this item.

Decision:

The Sector agreed to Withdraw the item and anticipates Mr. Karimov will introduce a new item that combines Items 2, 3, and 4 from the 2012 Sector Agenda and which includes a detailed draft in the format of the Product Families Table.

4. Product Families Table – Consolidate Product Categories for PD and Turbine Meters

Source:

Dmitri Karimov, Liquid Controls

Background:

The submitter believes that NCWM Publication 14 (Pub 14) has too many agri-chemical products categories for PD and turbine meters that were created many years ago and are outdated. Note that this item relates to the proposal in Agenda Item 3 to match PD and turbine product categories.

At the conclusion of its 2011 meeting: The Sector voted on a proposal to add a note, as shown below, to the LMD Technical Policy.

If a PD or turbine meter is approved for a product of low viscosity in one product family or category and the same model meter is approved for a product of high viscosity in another product family or category, the meter will be approved for this viscosity range in both product families/categories.

The proposal and the results of the vote shown below were forwarded to the NTEP Committee.

Approve: 7
Oppose: 5
Abstain: 0

Note: All three labs and NIST were opposed to the item as it was framed for the vote.

On January 21, 2012, the NTEP Committee returned the item to the Sector for further consideration noting that because the NTEP labs and NIST did not concur with the proposal, the conclusion did not represent a consensus among all segments of the membership.

Discussion:

The Sector discussed the responses of the NTEP Committee to the voting results of Agenda Items 2 and 4. Even though an overall majority of the Sector members had voted in favor of both items, the NTEP Committee could not regard the proposals as representing consensus recommendations since a majority of one of the membership segments voted against each item. Because the NTEP Committee regards the input and participation from each segment of the Sector membership as critical, the committee regards such cases as a strong indication that an item needs further development.

Mr. Henry Oppermann (Weights and Measures Consulting) suggested that aligning proposals with OIML standards is often helpful in avoiding gaps in understanding between public and private sector members of the Sector. Mr. Dennis Beattie (Measurement Canada) mentioned that Canada is also attempting to address the organization of product fluid properties and meter materials of construction for the purpose of determining appropriate testing requirements for type evaluation.

The submitter proposed withdrawing the item in recognition that there is no consensus support for the item as it is currently presented. Mr. Karimov plans to develop and submit a new item that will replace the current Agenda Items 2, 3, and 4.

Mr. Buttler mentioned that he is available to provide technical guidance to Mr. Karimov in developing the draft proposal. However, industry must develop the item to ensure that the interests of industry are reflected by the proposal. Mr. Karimov commented that he would focus primarily on the test requirements for turbine meters in the new proposal.

The NTEP labs noted that a reference tool similar to the Product Families table is needed to capture the critical properties for each individual fluid. Because the Product Families Table is not all-inclusive and only provides information on the typical range of critical property values for each product family, the values for individual products must be determined by some other means. The Sector noted that the Product Families Table does not currently include all fluid products sold commercially and agreed that such a tool would be useful to aid field inspectors in enforcement and NTEP labs during type evaluation. However, the Sector also noted that it would be cumbersome to maintain the increasing volume of data that would be needed to achieve this.

Decision:

The Sector agreed to Withdraw the item and anticipates Mr. Karimov will introduce a new item that combines Items 2, 3, and 4 from the 2012 Sector Agenda and which includes a detailed draft in the format of the Product Families Table.

The Sector requested that the Technical Advisor, Mr. Buttler, provide assistance by researching historical records for any information listing the various fluid product properties that were considered when the product families for PD and turbine meters were first drafted by Mr. Mel Hankel of Liquid Controls for the original Product Families Table proposal.

Technical Advisor's Note: Mr. Buttler located information from the NIST file on the 1991 Measuring Sector meeting and attached the information to this summary as Appendices C and D.

Appendix C is a scanned image of a detailed letter from Mel Hankel to NIST that describes the interrelations between meter materials of construction and fluid product properties that formed the basis of the original proposal to streamline NTEP type testing by grouping fluids together into families. Appendix D is a technical paper from Smith Meter Inc. that includes additional technical information about interactions between meters and fluids with varying properties.

Appendices C and D identify the following fluid properties as properties that were considered during the creation of the original Product Families Table:

- *Viscosity*
- *Specific Gravity*
- *Percent of Abrasive Solids*
- *Lubricity Service Factor*
- *Typical Flow Rate Range Ratio*
- *Corrosiveness*
- *Vapor Pressure*
- *Homogeneity*
- *Solids (Particulate) Content*
- *Typical Temperature Ranges*
- *Typical Pressure Ranges*
- *Boundary Layer Thickening*
- *Deposits (e.g., paraffin)*

The 1991 discussion also noted that, at the time, Liquid Controls was producing 15 PD meter classes using various different materials of construction to address the anticipated range of these various fluid properties.

One additional fluid property was the subject of discussion in the 1991 Sector meeting. Entrained vapor/air resulting from agitation of fluids (e.g., fertilizers) was discussed at length with respect to the impact on effectiveness of the vapor/air elimination means of some measuring systems. Multiple fluid properties (e.g.,

viscosity and surface tension) will determine how entrained vapor/air will be dispersed in an agitated fluid and how quickly and effectively the entrained vapor/air can be eliminated.

The information from the 1991 Measuring Sector archive, Appendices C and D, in combination with more recent data from industry regarding the effects of various fluid properties on the latest metering technologies should be helpful to Mr. Karimov in developing the new proposal referenced above. If it can be shown which of the properties from the list above are the key characteristics for each of the currently defined product families, this understanding could then help to justify the specific details of a reorganization and consolidation of the Product Families Table.

NEW ITEMS:

5. Pictograms for “Setup or Configuration Mode Enabled”

Source:
 NTEP Measuring Labs

Background:

At the spring 2012 meeting of the NTEP measuring labs, the labs agreed that pictogram  is clear and acceptable indication of the status of the setup or configuration mode while sealing a device. To clarify acceptability of pictograms such as these, it is proposed that an example be added under the heading of Acceptable Clear Indications to the list of indications representing that the device is configured with the setup or configuration mode enabled.

Recommendation:

The Sector was asked to consider adding a pictogram to the sealing checklist table under examples of Acceptable Clear Indications that a device has the setup or configuration mode enabled as shown in the lower left corner of the figure below.

Indications representing that the device is configured with the setup or configuration mode enabled (i.e., any mode permitting access to any or all sealable parameters)	
This list is not limiting or all-inclusive; other indications may be acceptable.	
Acceptable Clear Indications	Indications NOT Acceptably Clear
Unusable quantity indications Example: C100.05E	C 100.05 gal
“not HB 44 ” annunciator	Any digit in the quantity differentiated by size, shape, or color
“CAL” annunciator (single or mixed case)	Quantities w/o units Example. 100.05
“Set-up” annunciator	Flashing quantity value

<p>Indications representing that the device is configured with the setup or configuration mode enabled (i.e., any mode permitting access to any or all sealable parameters)</p> <p>This list is not limiting or all-inclusive; other indications may be acceptable.</p>	
<p>Acceptable Clear Indications</p>	<p>Indications NOT Acceptably Clear</p>
<p>(single or mixed case)</p>	
<p>“Config” annunciator (single or mixed case)</p>	<p>Quantity with no annunciators displayed</p>
	<p>Quantity all annunciators displayed</p>

It was also recommended that the Sector consider adding an accompanying checklist table to show examples of optional indications that a device is in the sealed mode or has setup or configuration mode disabled. Indication of this mode is currently neither required nor prohibited in NIST Handbook 44.

<p><u>Indications (optional) representing that the device is configured with the setup or configuration mode disabled (i.e., no access to any or all sealable parameters)</u></p> <p><u>This list is not limiting or all-inclusive; other indications may be acceptable.</u></p>
<p><u>Acceptable Clear Indications</u></p>

Discussion:

The Technical Advisor summarized the two parts of the proposal:

- the addition of a pictogram example to the existing table of indications representing that the device is configured with the setup or configuration mode enabled, and
- the addition of a second table to show examples of indications representing that the device is configured with the setup or configuration mode **disabled**.

The Sector first discussed the existing table of indications representing that the device is configured with the setup or configuration mode enabled. The Sector noted that NCWM Publication 14 does not now prohibit the use of pictograms. The Sector agreed that adding examples of acceptable pictograms could avoid confusion as to whether pictograms are acceptable and would provide manufacturers that are submitting new devices with the pictogram options that have been reviewed previously and determined to be clear indications.

The Sector noted that the location of the title of the table as it appears in the proposal was inside the top cell of the table, and that this was in contrast to the location of the title of the table as separate text above the table where it currently appears in NCWM Publication 14. It was proposed that the table title and the note indicating that the list is not all-inclusive should remain as separate text above the table. The Sector agreed to keep the title and the note above the table to remain consistent with the way that other similar tables appear in NCWM Publication 14.

The Sector discussed the requirement found in Table S.2.2. “Categories of Device and Methods of Sealing” from the LMD Code in NIST Handbook 44 that applies to Category 2 and Category 3 devices:

The device shall clearly indicate that it is in the remote configuration mode and record such message if capable of printing in this mode or shall not operate while in this mode.

The Sector noted that there is no corresponding specific requirement in NIST Handbook 44 for a device to indicate when the remote configuration mode is **not** enabled. The Sector’s interpretation of this is that, although it is permitted for a device to indicate when the remote configuration mode is not enabled, it is only required for the device to indicate when the remote configuration mode is enabled. A concern was raised about adding examples of indications that are permitted but are not required. The Sector ultimately decided not to add the additional table that was proposed which would have listed the optional indications representing that the device is configured with the setup or configuration mode disabled.

Decision: The Sector unanimously agreed to propose adding the pictogram example and the additional wording to the note under the title of the existing table as shown underlined below. The Sector also decided not to include the new additional table that had been proposed to show optional indications representing that the device is configured with the setup or configuration mode “disabled.”

The title, note, and table should appear with the revisions as shown here:

Indications Representing That the Device is Configured with the Setup or Configuration Mode Enabled (i.e., any mode permitting access to any or all sealable parameters)

This list is not limiting or all-inclusive; other indications or pictograms may be acceptable.

Acceptable Clear Indications	Indications NOT Acceptably Clear
<ul style="list-style-type: none"> • Unusable quantity indications Example: C100.05E • “not HB 44” annunciator • “CAL” annunciator (single or mixed case) • “Set-up” annunciator (single or mixed case) • “Config” annunciator (single or mixed case) •  	<ul style="list-style-type: none"> • C 100.05 gal • Any digit in the quantity differentiated by size, shape, or color • Quantities w/o units Example: 100.05 • Flashing quantity value • Quantity with no annunciators displayed • Quantity all annunciators displayed

6. Utility Water Meter Repeatability Tolerances

Source:
 NTEP Measuring Labs

Background:
 The new Section L “Laboratory Evaluation and Permanence Tests for Utility Type Water Meters” that was added to NCWM Publication 14 in 2012 includes repeatability tolerance values for utility-type meters. At the spring 2012 meeting of the NTEP measuring labs, the labs recommended that these tolerance values be removed from NCWM Publication 14. Tolerance values are published in NCWM Handbook 44, and it is standard practice to refer to NIST Handbook 44 as the sole location of all tolerance values.

Recommendation:
 The Sector was asked to consider removing the tolerance values for utility-type water meters from NCWM Publication 14 as shown below.

L. Laboratory Evaluation and Permanence Tests for Utility Type Water Meters

All new-design meters are subject to a permanence test. NTEP reserves the right to require a permanence test based on the results of the initial examination.

Initial Examination

1. All meters of the new type installed at the type evaluation location are subject to evaluation. At least three meters of the same model must be tested.
2. At least three meters will be chosen for throughput testing on water. The minimum number of tests to be conducted for each of these meters will include the following:
 - Three tests at the maximum flow rate
 - Three tests at the intermediate flow rate
 - Three tests at the minimum flow rate
3. All meters must perform within acceptance tolerance.
4. Repeatability – When multiple tests are conducted at approximately the same flow rate, each test shall be within the applicable tolerances and the range of test results shall not exceed repeatability tolerance. ~~the following values:~~
 - ~~1. 0.6 percent for tests conducted at Normal Flow Rates~~
 - ~~2. 2.0 percent for tests conducted at Intermediate Flow Rates~~
 - ~~3. 4.0 percent for tests conducted at Minimum Flow Rates~~

Subsequent Examination

1. Following the period of use, the tests listed above are to be repeated. All results within the range of flow rates are to be included on the certificate of conformance provided the results are within the applicable tolerances.
2. The examination will be conducted as applicable:
 - 200 000 gallons for throughput testing for mechanical changes of metrological significance
 - Flow rates during throughput testing are not to exceed 50 % of the manufacturers rated maximum flow rate
3. Three tests at maximum, intermediate and minimum flow rate will be made on the throughput meters. Only one test at each flow rate needs to be performed on any remaining meters.
4. Repeatability – When multiple tests are conducted at approximately the same flow rate, each test shall be within the applicable tolerances and the range of test results shall not exceed repeatability tolerance. ~~the following values:~~
 - ~~1. 0.6 percent for tests conducted at Normal Flow Rates~~
 - ~~2. 2.0 percent for tests conducted at Intermediate Flow Rates~~
 - ~~3. 4.0 percent for tests conducted at Minimum Flow Rates~~

Discussion:

The Sector discussed the item and agreed that the convention in NCWM Publication 14 of not listing tolerance values, but rather referring directly to NIST Handbook 44 for tolerance values should apply for water meters as well.

Technical Advisor's Note: Clarifications that repeatability tests are three or more consecutive tests were added as an editorial change to reflect paragraph N.4.1.1. "Repeatability Tests" in the HB 44 Water Meters Code."

Decision:

The Sector unanimously agreed to propose removing the tolerance values for utility-type water meters from NCWM Publication 14 as shown below.

L. Laboratory Evaluation and Permanence Tests for Utility Type Water Meters

All new-design meters are subject to a permanence test. NTEP reserves the right to require a permanence test based on the results of the initial examination.

Initial Examination

1. All meters of the new type installed at the type evaluation location are subject to evaluation. At least three meters of the same model must be tested.
2. At least three meters will be chosen for throughput testing on water. The minimum number of tests to be conducted for each of these meters will include the following:
 - Three tests at the maximum flow rate
 - Three tests at the intermediate flow rate
 - Three tests at the minimum flow rate
3. All meters must perform within acceptance tolerance.
4. Repeatability – When ~~multiple~~ three or more consecutive tests are conducted at approximately the same flow rate, each test shall be within the applicable tolerances and the range of test results shall not exceed repeatability tolerance, the following values:
 - ~~1. 0.6 percent for tests conducted at Normal Flow Rates~~
 - ~~2. 2.0 percent for tests conducted at Intermediate Flow Rates~~
 - ~~3. 4.0 percent for tests conducted at Minimum Flow Rates~~

Subsequent Examination

1. Following the period of use, the tests listed above are to be repeated. All results within the range of flow rates are to be included on the certificate of conformance provided the results are within the applicable tolerances.
2. The examination will be conducted as applicable:
 - 200 000 gallons for throughput testing for mechanical changes of metrological significance
 - Flow rates during throughput testing are not to exceed 50 % of the manufacturers rated maximum flow rate
3. Three tests at maximum, intermediate and minimum flow rate will be made on the throughput meters. Only one test at each flow rate needs to be performed on any remaining meters.
4. Repeatability – When ~~multiple~~ three or more consecutive tests are conducted at approximately the same flow rate, each test shall be within the applicable tolerances and the range of test results shall not exceed repeatability tolerance, the following values:
 - ~~1. 0.6 percent for tests conducted at Normal Flow Rates~~
 - ~~2. 2.0 percent for tests conducted at Intermediate Flow Rates~~
 - ~~3. 4.0 percent for tests conducted at Minimum Flow Rates~~

7. Water Meters Permanence Flow Rates

Source:

NTEP Measuring Labs

Background:

The new Section L “Laboratory Evaluation and Permanence Tests for Utility Type Water Meters” that was added to NCWM Publication 14 in 2012 includes a restriction preventing throughput flow rates to 50 % of maximum rated flow rate and below. The NTEP labs report that past laboratory throughput testing of water meters has been run with flow rates near the maximum rated flow rate. Water meters in service are often found that are nearly continuously subjected to flow at close to the maximum rated flow rate. The labs feel it is important to be able to conduct testing under the conditions in which the meters will be used.

Recommendation:

The Sector was asked to consider removing the restriction in Section L that prevents throughput flow rates above 50 % of maximum rated flow rate as shown below.

Subsequent Examination

1. Following the period of use, the tests listed above are to be repeated. All results within the range of flow rates are to be included on the certificate of conformance provided the results are within the applicable tolerances.
2. The examination will be conducted as applicable:
 - 200 000 gallons for throughput testing for mechanical changes of metrological significance
 - ~~Flow rates during throughput testing are not to exceed 50 % of the manufacturers rated maximum flow rate~~
3. Three tests at maximum, intermediate, and minimum flow rate will be made on the throughput meters. Only one test at each flow rate needs to be performed on any remaining meters.
4. Repeatability – When multiple tests are conducted at approximately the same flow rate, each test shall be within the applicable tolerances and the range of test results shall not exceed repeatability tolerance.

Discussion:

The Sector revisited the question of what limit, if any, is appropriate to place on the throughput flow rate during permanence testing of utility type water meters. Mr. John Roach (CA DMS NTEP Lab) said that the water meter testing in California regularly runs throughput flow rates on ⁵/₈-inch meters at 15 gpm. He also mentioned that utility type water meters of similar size would often run continuously at this same high flow rate while in service. Sector members agreed that, for a permanence test to be valid, the meter should be allowed to run throughput at a flow rate similar to that at which a meter of the type is expected to see in service.

Mr. Andre Noel (Neptune Technology Group, Inc.) explained that there appears to be confusion when referring to the “manufacturer’s rated maximum flow rate” resulting from a difference in nomenclature between NCWM Publication 14; the ANSI/AWWA C700 “AWWA Standards for Cold-Water Meters”; and the Water Meters Code (Section 3.36.) in NIST Handbook 44. In the AWWA standard, the “recommended maximum rate for continuous operations” for cold-water meters is limited to 50 % of the “safe maximum operating capacity” flow rate. AWWA C700 describes the “safe maximum operating capacity” as the maximum rate of flow that water should be passed through the meter. AWWA adds that the maximum rate should extend only for short periods of time and at infrequent intervals, and that maximum flow could be destructive if continuous.

Mr. Noel further explained that the flow rates for normal tests listed in Table N.4.1. in the Water Meters Code in NIST Handbook 44 are lower than the “safe maximum operating capacity” flow rate values in AWWA C700. The limit on the throughput of “50 % of the manufacturer’s rated flow rate” currently stated in Section L of NCWM Publication 14 was intended to prevent continuous throughput flow at “safe maximum operating capacity” flow rates and thus avoid the potential destructive effects of continuous flow at those rates.

Since neither the “manufacturer’s rated flow rate” from NCWM Publication 14 nor the “safe maximum operating capacity” from the AWWA standard are terms that are currently referenced or defined in NIST Handbook 44, the Sector agreed to reword the description of the throughput flow rate limit in Section L of NCWM Publication 14 using terms referenced in NIST Handbook 44 and AWWA C700. Mr. Noel and other Sector members agreed that the throughput flow rates for water meters should be allowed to run at 100 % of the normal test flow rates in the NIST Handbook 44 Water Meters Code Table N.4.1. or up to the manufacturer’s recommended maximum rate for continuous operations, if that is higher. Mr. Roach confirmed that these flow rates represent the testing practices that are currently in place in California and are also reflective of normal continuous use conditions for utility type water meters.

Decision:

The Sector unanimously agreed to propose revisions to the wording of the “Subsequent Examination” steps in Section L of NCWM Publication 14 as shown below to resolve the nomenclature differences between NCWM Publication 14 and AWWA C700.

Subsequent Examination

1. Following the period of use, the tests listed above are to be repeated. All results within the range of flow rates are to be included on the certificate of conformance provided the results are within the applicable tolerances.
2. The examination will be conducted as applicable:
 - 200 000 gallons for throughput testing for mechanical changes of metrological significance
 - Flow rates during throughput testing are not to exceed **the normal flow rate from HB 44 or a stated maximum continuous flow rate from the manufacturer, if it is greater than the normal flow rate. 50% of the manufacturers rated maximum flow rate**
3. Three tests at maximum, intermediate and minimum flow rate will be made on the throughput meters. Only one test at each flow rate needs to be performed on any remaining meters.
4. Repeatability – When multiple tests are conducted at approximately the same flow rate, each test shall be within the applicable tolerances and the range of test results shall not exceed **repeatability tolerance, the following values:**
 1. **0.6 percent for tests conducted at Normal Flow Rates**
 2. **2.0 percent for tests conducted at Intermediate Flow Rates**
 3. **4.0 percent for tests conducted at Minimum Flow Rates**

8. Clarify Scope of Technical Policy R (VTM and Stationary) - Applicability to both Meters and Registers

Source:
NIST OWM

Background:

At their April 2000 meeting, the NTEP laboratories agreed that if a meter is successfully tested in a vehicle-mounted application, the resulting CC could cover both vehicle-mounted and stationary applications without additional testing in a stationary application. The labs forwarded a proposal to the Measuring Sector to add a new paragraph to the Technical Policy for Liquid-Measuring Devices, and this resulted in the addition of Technical Policy R “Vehicle-Mounted and Stationary Applications of the Meter” to Pub 14.

Since it was originally developed, Technical Policy R has referred only to “the meter.” NIST has received inquiries from industry requesting clarification on whether the scope of Technical Policy R is intended to include registers. Discussion notes from the 2000 Measuring Sector meeting confirm that the proposal was originally based on recognition that the vehicle-mounted application is the worst case of the two scenarios. There is no mention of any intention to exclude registers from the scope of this conclusion.

Recommendation:

The Sector was asked to consider clarifying Technical Policy R to include registers within the scope as shown in the decision below.

Discussion:

The Sector discussed the item and all agreed that the scope of Technical Policy R was intended to include both meters and registers. Several suggestions were offered to clarify the language that was initially proposed. However, after some discussion, all agreed to leave the original language of the proposal intact..

Decision:

The Sector unanimously agreed to propose the change as it appears below.

R. Vehicle-Mounted and Stationary Applications of the Meters and Registers

If a meter or register is successfully tested in a vehicle-mounted application, both vehicle-mounted and stationary applications can be covered on the resulting NTEP Certificate of Conformance (CC) without additional testing in a stationary application provided all other suitability criteria have been met (e.g., flow rates). If a meter or register evaluation has only been conducted in a stationary application, testing

must also be conducted on the meter or register in a vehicle-mounted application in order to cover both applications on the NTEP CC.

9. Product Families Table - Correct the Units for the Turbine Meter’s Critical Parameter of Kinematic Viscosity to Centistokes (cSt) in the Product Families Table

Source:

Marc Buttler, NIST OWM

Background:

In 2010, the Measuring Sector recommended a new format to reorganize the Product Families Table of Technical Policy C. The NTEP Committee approved the new format of the table and it was published in the 2011 edition of NCWM Publication 14.

The Sector had been working to develop the new format since 2006, but limited the scope of these discussions to revising the format and not the content of the table. See the 2006 – 2010 Measuring Sector Meeting Summaries for details.

The way in which viscosity units were presented in the older format of the table led to an error in how the content was translated to the new format. Viscosity units for both PD and turbine meters had previously been combined in the old format in a single column labeled “Viscosity (Centipoise Centistokes).” The correct unit for the critical parameter of “kinematic viscosity” that applies to turbine meters is centistokes (cSt). The correct unit for the critical parameter of “dynamic viscosity” that applies to PD meters is centipoise (cP). Dynamic viscosity is commonly referred to as either just “viscosity” or sometimes “absolute viscosity.”

The relationship between centistokes and centipoise is shown in the following equations:

$$\text{centistokes (10}^{-6} \text{ m}^2/\text{s)} = \text{centipoise (10}^{-3} \text{ kg/m}\cdot\text{s)} \div \text{density (kg/m}^3\text{)}$$

OR

$$\text{centistokes (cSt)} = 1.002 \times \text{centipoise (cP)} \div \text{density (SG)} \quad [\text{Where } 1 \text{ SG} = 998 \text{ kg/m}^3]$$

In the Product Families Table, Test E, which has always been reserved exclusively for turbine meters, specifies kinematic viscosity as the correct critical parameter for turbine meters.

Test E

To cover a range of products within each product category, test with one product having a low **kinematic viscosity** and test with a second product having a high **kinematic viscosity** within each category. The Certificate of Conformance will cover all products in the product category within the **kinematic viscosity** range tested.

Furthermore, the approved range of kinematic viscosity in active turbine meter CCs is identified using units of centistokes as the critical parameter.

Recommendation:

The Sector was asked to consider correcting the unit labeling of all references to kinematic viscosity under the turbine meter columns of the Product Families Table in Technical Policy C to centistokes (cSt) as shown in the example below. A complete markup with all changes to the table was provided (Appendix E). In addition to the corrections of the unit labels, the markup also included updated kinematic viscosity values for each product that were computed from the dynamic viscosity and density values found for each product elsewhere throughout the table. The conversions between units of centipoise and centistokes in Footnote 1 of the table were also clarified in the Attachment 3 markup.

Turbine Flow Meter	
Product Category and Test Requirements	
<u>Test E</u>	
To cover a range of products within each product category, test with one product having a low kinematic viscosity and test with a second product having a high kinematic viscosity within each category. The Certificate of Conformance will cover all products in the product category within the kinematic viscosity range tested. ¹	
Product Category:	
Alcohols, Glycols and Water Mixes Thereof (Alc Gly)	
Typical Products	Reference <u>Kinematic</u> Viscosity¹ (60 °F) <u>Centipoise (cP)</u> <u>Centistokes (cSt)</u>

Discussion: Mr. Buttler (NIST, OWM) reviewed how the error in units of viscosity occurred during the translation of the Product Families Table into the new format. Mr. Buttler also explained how the corrected values for kinematic viscosity for turbine meters in the proposed table shown in Appendix E were derived from other values already in the table. Values for dynamic viscosity in centipoise from the PD meter column of the table and SG values from the mass meter column were used in the formula stated above and in the footnote below the table to compute the kinematic viscosity values in the turbine meter column. Correcting the units to kinematic viscosity for turbine meters is essential to preserve the technical accuracy of the table, as well as the accuracy of active CCs that already state kinematic viscosity ranges for approved turbine meters in units of centistokes (e.g., CC 04-097A3).

Decision:

The Sector unanimously agreed to propose the changes as shown in Appendix E.

10. Post-Delivery Discounts and Electronic Receipts

Source:

2012 NCWM S&T Committee Item 330-1 (Unit Price Posting and Selection Requirements)

Background:

At the 2012 NCWM Annual Meeting, S&T Item 330-1 was approved to update specifications in NIST Handbook 44 to address current marketing methods for offering pricing discounts beyond simple cash/credit pricing and to establish a framework for “post-delivery” discounts offered after the delivery of fuel is complete.

Recommendation:

The Sector was asked to update the LMD and ECR-RMFD checklists to reflect the new requirements relating to post-delivery discounts and availability of electronic receipts.

Draft copies of Appendix F (LMD checklist) and Appendix G (ECR-RMFD checklist) were provided by the technical advisor. Revisions were proposed to portions of the checklists that reference the following paragraphs in the NIST Handbook 44 LMD Code (Section 3.30.):

- S.1.6.4.1. Unit Price
- S.1.6.5.4. Selection of Unit Price
- S.1.6.6. Agreement Between Indications
- S.1.6.7. Recorded Representations
- UR.3.2. Unit Price and Product Identity

Discussion:

The Technical Advisor, Mr. Buttler, presented first drafts of Appendices F and G to the Sector and explained that they were draft revisions to the NCWM Publication 14 LMD and ECR checklists which were developed in response to new LMD unit price posting and selection options and requirements adopted by the S&T Committee at the 2012 NCWM Annual Meeting for inclusion in NIST HandbookB 44. Because of the short window of time between the finalization of the new requirements and Measuring Sector meeting, there was no opportunity for review of the drafts by any Sector members prior to the Measuring Sector meeting. Mr. Buttler explained that the Retail Motor-Fuel Dispensers Price Posting and Computing Capability (RMFD PPCC) Task Group, which had been responsible for developing the new options and requirements, was asked by the S&T Committee to continue their work by developing examples and interpretations that would aid weights and measures officials and industry in interpreting and applying the requirements, and the Measuring Sector in updating the LMD and ECR checklists. However, that follow-up task is not yet complete and the Task Group has not yet set a target date for completion.

The NTEP Director, Mr. Jim Truex (NCWM), explained that in this situation, some urgent action was warranted to address the anticipated need for NTEP labs to be prepared for applications involving devices that would comply with some or all of the new options and requirements that were adopted. He asserted that these additional options were now going to be allowed in NIST Handbook44. Thus, the Measuring Sector and the NTEP labs could not afford to wait for delivery of the examples and interpretations by the RMFD PPCC Task Group, and must instead take some immediate action to establish interpretations and guidelines for use in type evaluation.

The Sector discussed the situation and agreed to do whatever was possible to complete the minimum updates to the checklists that would be needed to meet immediate needs in the short term without waiting for the anticipated deliverables from the RMFD PPCC Task Group. Furthermore, the Sector realized that additional revisions to the checklists might be required in the future in order to make use of the deliverables from the Task Group once they are provided.

Mr. Jerry Buttler (North Carolina NTEP Lab) raised a question about stacked sales, “Will the console be able to retain all the necessary dispenser information long enough when there is a long delay between the fuel delivery and the customer action that qualifies for a post-delivery discount?” This scenario seems likely, as it is anticipated that shopping and purchasing items inside a convenience store is one likely action that would trigger a post-delivery discount. The Sector discussed this and concluded that the requirements for stacked sales and for what must appear on the receipt when a post-delivery discount is applied would apply to these systems. Furthermore, the Sector concluded that design and use for compliance with these requirements must be addressed by the manufacturers and users/owners of these devices and systems if post-delivery discounts are to be offered. However, the further concern was raised as to whether the checklists fully address the need to assure that long delays in completing stacked sales do not present problems for some devices and systems.

Mr. Chris Willeke (Bright Solutions, LLC) raised a concern that, for tax reporting purposes, the International Fuel Tax Association (IFTA) may require that the net unit price of the fuel be stated by trucking operations for all purchases. The concern was based on the potential scenario where a receipt from a fuel sale would include all the information required in the new NIST Handbook 44 paragraph S.1.6.8. “Recorded Representations for Transactions Where a Post-Delivery Discount(s) is Provided,” including the: total quantity, unit price, and total computed price shown at the dispenser prior to the post-delivery discount; an itemization of the post-delivery discounts to the unit price; and the final total computed price of the fuel sale. However, because the receipt is not required to include the final computed unit price paid for the fuel that includes all post-delivery discounts, it would require truck operators to do a substantial amount of additional calculations to compute the values when preparing tax reports. Mr. Rich Tucker (RL Tucker Consulting LLC) asked if the post-delivery discounts applied to the unit price would need to be reported or would the unit price at the pump be reported, since the discount would be applied after the fuel was delivered. Mr. Willeke consulted with some of his staff and later confirmed that the report that truck operators must submit does not require the unit price, only the net total computed price for the fuel. Learning this, the Sector agreed that the issue was resolved, since the net total computed price for the fuel is required to appear on the receipt.

After the above discussion, the group of volunteers listed below agreed to reconvene following the first day of the Sector meeting to work on the checklist drafts:

Jerry Butler, NC NTEP Lab
Marc Buttler, NIST OWM Technical Advisor
Mike Frailer, MD NTEP Lab
Gordon Johnson, Gilbarco, Inc.

Henry Oppermann, W&M Consulting
Jim Truex, NCWM NTEP Director
Rich Tucker, RL Tucker Consulting LLC

During the evening session, Mr. Oppermann suggested that the order in which certain checklist items and code references appear in the LMD checklist needed to be reorganized in order to place these items in the correct section of the checklist and to ensure they are applied to all the intended types of devices. The Task Group relocated the code reference S.1.6.5.4. “Selection of Unit Price” and its associated checklist items from Section 8 “Computing” to Section 7 “Indicating and Recording Elements” in order to locate the checklist items that are related to the selection of unit price together with the code reference S.1.6.4.1. “Display of Unit Price” and its associated checklist items. The code reference S.1.6.8. “Recorded Representations for Transactions Where a Post-Delivery Discount(s) is Provided” and its associated checklist items needed to be located in multiple locations to ensure that the checklist items are applied to general retail motor fuel dispensers, card-activated devices, and cash-activated devices, when appropriate.

The volunteers successfully completed their review and presented their results as shown in Appendices F and G the next day.

Decision:

The Sector reviewed the revised proposals and unanimously agreed to propose them as shown in Appendices F and G to the NTEP Committee for inclusion in NCWM Publication 14.

11. NCWM Pub 14, NTEP Administrative Policy Revision

Source:

NTEP

Background:

NCWM is working to revise Pub 14, Administrative Policy to put it in a more logical order and more understandable form. The purpose is not to change the intent of the document, rather to realign and clarify sections as necessary.

Discussion:

Mr. Truex explained that the purpose of the proposed revision of the Administrative Policy of NCWM Publication 14 was to streamline the document and to address aspects of the current version that some people had found confusing. He further explained that the proposal was not intended to change the meaning of any aspect of the policy, only to reorganize and clarify. Since the Administrative Policy section of NCWM Publication 14 is not the responsibility of any specific Sector to maintain, the modified draft version has been distributed widely to the members of all NTETC Sectors. Mr. Truex reported that all other Sectors have reviewed the draft and reported no major problems. Mr. Oppermann also reported having reviewed the draft and indicated his support.

Mr. Truex requested that all recommendations and concerns from individuals, if there are any, be provided directly to him prior to the 2013 NCWM Interim Meeting, if possible.

Decision:

The Sector members agreed to provide any comments on the proposed revisions to the Administrative Policy of NCWM Publication 14 directly to Mr. Truex.

ADDITIONAL ITEMS AS TIME ALLOWS:

The Measuring Sector was asked to provide input on the following measuring-related issues on its agenda if time permitted during the Sector Meeting. In the interest of brevity, the narrative for each item is abbreviated to the extent practical. Full descriptions of NCWM S&T Committee items can be found in the S&T Committee’s list of carryover items and its 2012 Final Reports.

12. Windshield Washer Fluid Vending Units

Source:

Chris Willeke, Bright Solutions

Background:

A manufacturer seeking preliminary guidance on requirements for windshield washer fluid vending units asked for input on the application of NIST Handbook 44 and NCWM Publication 14 to these devices. Specific language for NCWM Publication 14 and NIST Handbook 44 have not yet been developed.

Recommendation:

The Sector was asked to consider the application and recommend the most appropriate path to address the following issues for windshield washer fluid vending devices:

- Determine the appropriate code section from NIST Handbook 44 that applies to this application and whether any changes or additions to either NIST Handbook 44 and/or NCWM Publication 14 are required.
- Determine what changes or additions to either NIST Handbook 44 and/or NCWM Publication 14 are appropriate to recognize the proposed method of dispensing without an indication of the total quantity delivered and with a time-out function. The submitter suggests using language that can be found in the California Type Evaluation Program (CTEP) standards for testing and certifying water vending units as a starting point. However, these standards do not address specifications or testing of the time-out function.

Discussion:

Mr. Michael Keilty (Endress and Hauser) explained that this item is not a NCWM Publication 14 issue, but a manufacturer is seeking input from the sector on how the code would apply for an NTEP evaluation. The Sector did not object to hearing the item.

Mr. Chris Willeke (Bright Solutions, LLC) explained the system's functioning and answered questions from other Sector members about how the device functions. The system is designed primarily to be installed on the island in fueling stations near the motor-fuel dispensers. It delivers discrete pre-authorized quantities of windshield washer fluid through a hose and nozzle that is intended to be used by customers to fill the reservoir in their vehicle during fueling stops. The device is capable of meeting a 0.75 % tolerance and typically discharges product at a flow rate close to 1 gpm.

As part of his presentation, Mr. Willeke shared a system diagram that included a totalizer and a Point of Sale (POS) display. Mr. Willeke explained that the totalizer does not return to zero or display the indications of total quantity, unit price, or computed price for each transaction that would be required to comply with the LMD Code. There is a discharge valve on the nozzle that is controlled by the customer. The POS system is used solely to purchase and pre-authorize the delivery of a discrete pre-set amount (e.g., 1 gal). However, if the customer does not allow the full amount to be delivered through the discharge valve within a certain time limit, the device is automatically reset and the quantity that remains undelivered is forfeited by the customer. Mr. Willeke also confirmed that there is no indication of the amount that was forfeited. The time limit is measured from the time the transaction is first authorized and cannot otherwise be controlled by the customer.

Mr. Willeke noted that the State of Wisconsin required this device to have an NTEP CC before it could be placed into commercial service. Mr. Willeke suggests that similar devices are in service now in some jurisdictions to vend water. The main difference between these devices and the proposed method is that water vending machines are designed to always deliver the full quantity of what was purchased into an empty container of known volume. Because water vending machines always dispense the full amount that was purchased, the selected preset amount can serve as the indication of the quantity that was delivered. Water vending machines have no customer-controlled nozzle, so there is no need for a time-out function that resets the transaction, possibly retaining an undisclosed amount of undelivered product. However, no standards or test methods exist in NIST Handbook 44 or NCWM Publication 14 that could be employed to ensure that the time-out function of the windshield washer vending machine, as it is described, is operating as intended and not in a way that could facilitate fraud.

The NTEP labs were uncertain what code could be applied for NTEP evaluation because of some of the unique characteristics of the device. The CA DMS NTEP Lab described CTEP approval of water vending machines as the example of equipment that is perhaps most similar to the windshield washer fluid vending machine. Mr. John Roach (CA DMS NTEP Lab) explained that CA borrows from the Water Meters Code for tolerance values when they evaluate water vending machines for CTEP approval because there is no national code that would apply to these devices.

The Sector members made comparisons between the system that was described by Mr. Willeke and other commercial devices, including timing devices used in air compressors for filling tires, water vending machines, DEF dispensers, and slow flow liquid-measuring devices used to sell fuel additives. At the end of the discussion, the consensus was that the way that this system currently functions does not comply with any existing set of requirements in NIST Handbook 44. Many members of the Sector expressed opinions that the device would need to be modified to comply with the LMD Code in order to seek NTEP approval.

Mr. Dennis Beattie (Measurement Canada) questioned whether the LMD Code could be applied to the device because of paragraph A.2.(e), which states:

A.2. Exceptions. – This code does not apply to:

:
:
:

- (e) devices used solely for dispensing a product in connection with operations in which the amount dispensed does not affect customer charges;

This would potentially be true, unless a customer decided to purchase more than the initial discrete amount, in which case the total customer charges would be incrementally increased based on the measurement of the device each time it reached the pre-authorized quantity and stopped until more was purchased.

Mr. Truex offered an opinion that this is a method of sale issue. He added that the fuel additive device that was discussed earlier has a working display to comply with the LMD Code. Mr. Truex confirmed that there are no NTEP CCs on water vending machines. Mr. Truex suggested that this metering device does not clearly fit into any code in HB 44 and suggested contacting the NIST L&R experts for guidance. He stated that the recommendation Mr. Willeke received from WI to apply for an NTEP CC may have been incorrect and he will discuss the issue with Wisconsin Weights and Measures.

Decision:

There was no decision to be made by the Sector on this issue. The manufacturer expressed his gratitude to the Sector for considering the question of how to seek NTEP approval.

13. Hot Water Meters

Source:

Michael Dick, Norgas Metering Technologies, Inc.

Purpose:

Include provisions for type evaluation and NTEP certification of hot water meters.

Recommendation:

Neither NCWM Publication 14 nor NIST Handbook 44 specifically address water temperature in the sections related to water meters. The Sector was asked to consider whether specific testing requirements or other information are needed in NCWM Publication 14 and/or NIST Handbook 44 to support NTEP evaluation, testing, and certification of hot water meters that are designed to operate continuously in the range from 80 °F to 140 °F.

Background:

Submeter applications exist where individual tenants share a common water heating system. To accommodate accurate measurement of the hot water consumed by each tenant, NTEP certified meters capable of measuring the water after it has been heated (in the range from 80 °F to 140 °F) are needed.

The submitter is developing a proposal to establish requirements for these devices and has asked the Sector for preliminary guidance. Specific language for NCWM Publication 14 and NIST Handbook 44 has not yet been developed. The item was withdrawn by the submitter prior to the meeting; however, the Sector chose to discuss the item and determine if anyone else wanted to address the item.

Discussion:

Mr. Roach explained that California issues CTEP CCs which specifically identify “hot water” meters and “cold water” meters on the CC. CTEP requirements for hot water meters reference the AWWA handbook.

Mr. Truex explained that the original submitter of this item was requesting a “hot water” meter designation on an NTEP CC. He further explained that NTEP cannot issue a CC for a “hot water meter” since NIST Handbook 44 does not include a definition or requirements for “hot water meters.” The Water Meters Code in NIST Handbook 44 currently imposes no specific temperature restrictions on ordinary water meters beyond the limitations stated by the manufacturer. The individual was satisfied when NTEP agreed to include water temperatures that were used during testing under the “test conditions” section of an NTEP certificate that recognizes the device as an ordinary water meter as defined in Section 3.36. of NIST Handbook 44. Mr. Truex added that the temperature information would NOT appear on page 1 of the CC because stating this information on page 1 would imply something that has no basis in NIST Handbook 44.

The Sector went on to discuss whether there is a general need for NIST Handbook 44 to recognize hot water meters separately and with a different set of requirements than standard “cold” water meters. Mr. Ralph Richter (NIST, OWM) shared that OIML R 49 “Water meters intended for the metering of cold potable water and hot water” includes hot water meters and cold-water meters together. Mr. Andre Noel (Neptune Technology Group, Inc.) pointed out that some meters may be made of materials that are compatible with cold water, but not with hot water. Mr. Noel volunteered to raise this question with other water meter manufacturers to determine if any manufacturers are interested in developing this item as a proposal to the NCWM S&T Committee.

Decision:

The Sector agreed to carry over the item in the Additional Items as Time Allows Section to allow the water meter manufactures to determine whether it will merit further development.

14. Section 3.31. Vehicle-Tank Meters; Paragraph T.4. Product Depletion Test (S&T Carryover Agenda Item)

Source:

2012 NCWM S&T Agenda. Original source is the Northeast Weights and Measures Association (NEWMA).

Background:

The S&T Committee has been considering a proposal to modify the VTM Code to base the product depletion test tolerances on the meter’s maximum flow rate (a required marking on all meters), rather than the meter size (a required marking for meters manufactured beginning in 2009). This will enable more consistent application of the tolerances for older meters, which are not required to be marked with the meter size, and address an unintentional gap that allows an unreasonably large tolerance for smaller meters.

From 2009 to 2011, the Committee repeatedly requested data to support or oppose the various proposals under consideration with little success. At the 2011 Annual Meeting, the Committee reiterated its need for data to evaluate the impact of any proposed tolerances changes. Following that meeting, NIST Technical Advisor, Ms. Tina Butcher, on behalf of the Committee, distributed a request on NIST OWM Directors’ list serve asking weights and measures jurisdictions to submit data.

At the 2012 NCWM Interim Meeting, the Committee reiterated its position that tolerances for the product depletion test of a VTM should be based on the marked maximum flow rate of the meter rather than meter size. The Committee considered the three options for modifying NIST Handbook 44, including two options presented in its Interim Agenda and a third option submitted by the MMA prior to the meeting. A summary of the three options is outlined in the following table. A second table illustrating examples of tolerances for common meter sizes and maximum flow rates is also included.

Summary of Product Depletion Tolerance Options Considered		
	Marked Maximum Flow Rate or Meter Size	Tolerance (% of Marked Max Flow Rate)
Current	Up to but not including 2 in	104 in ³
	2 in up to but not including 3 in	137 in ³
	3 in and larger	229 in ³
Option 1:	All Maximum Flow Rates	0.5 %
Option 2:	Marked Max ≤ 100 gpm	0.6 %
	Marked Max > 100 gpm	0.5 %
Option 3:	Marked Max ≤ 60 gpm	0.8 %
	Marked Max > 60 gpm up to and including 100 gpm	0.6 %
	Marked Max > 100 gpm	0.5 %

Examples of Tolerance Options for Different Meter Sizes/Flow Rates					
Size	Marked Maximum Flow Rate (gpm)	Current Tolerance	Option 1 (0.5 % max)	Option 2 (0.6 % max) (0.5 % max)	Option 3 (0.8 % max) (0.6 % max) (0.5 % max)
1-1/2 in	60 gpm	104 in ³	69 in ³	83 in ³	111 in ³
2 in	100 gpm	137 in ³	115 in ³	139 in ³	139 in ³
2 in	150 gpm	137 in ³	173 in ³	173 in ³	173 in ³
3 in	150 gpm	229 in ³	173 in ³	173 in ³	173 in ³
3 in	200 gpm	229 in ³	231 in ³	231 in ³	231 in ³
3 in	300 gpm	229 in ³	346 in ³	346 in ³	346 in ³
3 in	350 gpm	229 in ³	404 in ³	404 in ³	404 in ³

During its Open Hearings at the 2012 Interim Meeting, the Committee heard support for Option 3 from members of the MMA. The Committee also heard a comment from Mr. Ross Andersen, who submitted the original proposal. Mr. Andersen pointed out that the tolerances in Option 1 were the same as those that apply prior to modifying the tolerance to be based on meter size.

S&T Technical Advisor, Mrs. Tina Butcher, NIST OWM, reported that the Committee received product depletion test data from nine state and county weights and measures jurisdictions. Mrs. Butcher distributed a summary to the Committee as shown in the following two tables. Mrs. Butcher noted that assumptions were made about meter size in some instances where meter size and/or maximum flow rate were not both provided. The first table summarizes the number of meters tested along with a comparison of the number that failed the current and proposed tolerances; the data includes a breakdown of meters in three different flow rate categories.

Summary of Product Depletion Test Data Submitted by State and County Weights and Measures Jurisdictions As of 1/20/12						
	Total Meters	Failed Current Tolerance	Failed Option 1	Failed Option 2	Failed MMA	Marked Max
Jurisdiction #1	67	0	2	1	1	---
	1	0	1	1	1	60 gpm
	53	0	1	0	0	100 gpm
	12	0	0	0	0	> 100 gpm
	1	0	0	0	0	??
Jurisdiction #2	9	0	0	0	0	No Data
Jurisdiction #3	288	21	33	22	20	---
	28	1	5	3	1	60 gpm
	228	17	25	16	16	100 gpm
	32	3	3	3	3	> 100 gpm
Jurisdiction #4	196	7	18	9	6	---
	14	0	3	3	0	60 gpm
	153	5	14	5	5	100 gpm
	29	2	1	1	1	> 100 gpm
Jurisdiction #5	134	7	12	7	7	---
	10	2	3	2	2	60 gpm
	72	4	8	4	4	100 gpm
	52	1	1	1	1	> 100 gpm
Jurisdiction #6	200	20	29	20	20	---
	0	0	0	0	0	60 gpm
	178	16	25	16	16	100 gpm
	22	4	4	4	4	> 100 gpm
Jurisdiction #7	196	13	14	13	13	---
	0	0	0	0	0	60 gpm
	150	11	12	11	11	100 gpm
	46	2	2	2	2	> 100 gpm
Jurisdiction #8	761	0	7	1	0	---

Summary of Product Depletion Test Data Submitted by State and County Weights and Measures Jurisdictions As of 1/20/12						
	Total Meters	Failed Current Tolerance	Failed Option 1	Failed Option 2	Failed MMA	Marked Max
	103	0	1	1	0	60 gpm
	629	0	6	0	0	100 gpm
	29	0	0	0	0	> 100 gpm
Jurisdiction #9	71	26	26	20	20	No Data

The second table provides a summary showing these totals for all jurisdictions combined.

	Total Meters	Failed Current Tolerance	Failed Option 1	Failed Option 2	Failed Option 3	Marked Max
Summary of All Jurisdictions	156	3	13	10	4	60 gpm
	1463	53	91	52	52	100 gpm
	222	12	11	11	11	>100 gpm
	81	26	26	20	20	No Info
Totals	1922	94	141	93	87	

At the 2012 NCWM Annual Meeting Open Hearings, Mr. Dmitri Karimov (Liquid Controls) speaking on behalf of the Meter Manufacturers Association, commented that, while MMA is aware that the Committee did not support MMA’s proposed “Option 3,” the MMA supports “Option 2” recommended by the Committee.

The Committee wishes to express its sincere appreciation to those jurisdictions that submitted data. The Committee discussed the data received and the summaries prepared by NIST OWM. The Committee recognizes that the data collected was not obtained under controlled conditions or as part of a structured survey or study; however, the data has been extremely valuable to the Committee in assessing the relative impact of the three options proposed. After discussing the comments and reviewing the summary of the data prepared by NIST OWM, the Committee agreed that Option 2 represents a reasonable compromise between the original proposal and the MMA’s proposal (designated Option 3 in the tables above). The Committee acknowledged that this item has included multiple proposals up to this point and it is important for the Committee to designate a single option for consideration by the NCWM in order that this item can progress. Consequently, the Committee is deleting the other options and presenting Option 2 for consideration. Because this item has included multiple proposals up to this point, the Committee decided to designate this item as an Information Item and is asking for input on the proposal as shown in the Item Under Consideration prior to moving the item forward as a Voting Item.

The Committee asks the regional weights and measures associations and industry for input regarding whether or not the proposed changes are ready for adoption in the next NCWM cycle.

Discussion:

Members of the MMA who were present at the Sector meeting shared that, although they still recommend “Option 3” as it was proposed to the S&T Committee, the MMA understands the deliberations of the S&T Committee and reluctantly supports the item moving forward as Option 2. The meter manufacturers in the MMA have discussed the latest position of the S&T Committee and agree they can “live with” and will support Option 2 in order to move the item forward.

The MMA's reluctance to support Option 2 was based on a concern that the tolerances in Option 2 are still too tight on smaller meters and they had offered "Option 3" to resolve this concern. The MMA believes that the failures of the smaller meter sizes in the data are mainly measuring system failures, not meter failures.

Decision:

The Measuring Sector discussed this item and learned that the MMA is supporting the item. The Sector, therefore, recommends that the S&T Committee move the item forward as a Voting Item using the language as described in Option 2.

NEXT MEETING:

The Sector discussed the time and location of the next meeting and all agreed to continue to keep the meeting in association with the SWMA. A proposal to hold the Sector meeting following the SWMA was discussed, but the Sector decided to keep the meeting prior to the SWMA, because the time following the SWMA is not available for some members.

Technical Advisor's Note: Since the Sector meeting, Mr. Keilty has received information that the 2013 SWMA Annual Meeting is scheduled to take place from October 7 - 9, 2013, in Charleston, West Virginia, at the Embassy Suites Hotel. The Measuring Sector Meeting is likely to be scheduled on October 4 - 5, 2013, in that location.

THIS PAGE INTENTIONALLY LEFT BLANK

Appendix D – Sub-appendix A

Agenda Item 1

Checklist for Testing Electronic Digital Indicators with Simulated Pulses October 3, 2009

This checklist is used for Technical Policy U. Evaluating electronic digital indicators submitted separate from a measuring element. **This section is intended for lab testing only. Is permanence necessary?**

Code Reference: G-S.1. Identification

All equipment shall be clearly and permanently marked on an exterior visible surface after installation. It must contain the following information (prefix lettering may be initial capitals, all capitals, or all lower case):

- 1.1. Name, initials, or trademark of the manufacturer. **Yes** **No** **N/A**
- 1.2. A model designation that positively identifies the pattern or design. The Model designation shall be prefaced by the word "Model", "Type", or "Pattern". These terms may be followed by the term "Number" or an abbreviation of that word. The abbreviation for the word "Number" shall, at a minimum, begin with the letter "N" (e.g., No or No.) The abbreviation for the word "Model" shall be "Mod" or "Mod." **Yes** **No** **N/A**
- 1.3. Except for not built-for-purpose, software-based devices, a nonrepetitive serial number. The serial number shall be prefaced by words, an abbreviation, or a symbol, that clearly identifies the number as the required serial number. Abbreviations for the word "Serial" shall, as a minimum, begin with the letter "S," and abbreviations for the word "Number" shall, as a minimum, begin with the letter "N" (e.g., S/N, SN, Ser. No, and S No.). **Yes** **No** **N/A**
- 1.4. For not built-for-purpose, software-based devices the current software version or revision designation. The version or revision identifier shall be prefaced by the word "Version" or "Revision" as appropriate and either word may be followed by the word "Number." The abbreviations for the word "Version" shall, as a minimum, begin with the letter "V". The abbreviation for the word "Number" shall, as a minimum, begin with the letter "N" (e.g., No or No.). **Yes** **No** **N/A**

Code Reference G-S.1. (e).

- 1.5. The NTEP Certificate of Conformance (CC) Number or a corresponding CC addendum number for devices that have a CC. The number shall be prefaced by the terms "NTEP CC", "CC", or "Approval". These terms may be followed by the word "Number" or an abbreviation for the Word "Number". The abbreviation shall as a minimum begin with the letter "N" (e.g., No or No.). **Yes** **No** **N/A**

The device must have an area, either on the identification plate or on the device itself, suitable for the application of the Certificate of Conformance Number. If the area for the CC Number is not part of an identification plate, then note its intended location below and how it will be applied.

Location of CC Number if not located with the identification:

Code Reference: G-S.1.1. Location of Marking Information for Not Built-for-Purpose, Software-Based Devices Not Built-for-Purpose Devices, Software-Based

- 1.6. For not built-for-purpose, software-based devices the following shall apply:
- 1.6.1. The required information in G-S.1 Identification. (a), (b), (d), and (e) shall be permanently marked or continuously displayed on the device; or
 - 1.6.2. The Certificate of Conformance (CC) Number shall be:
 - permanently marked on the device; or
 - continuously displayed; or
 - accessible through an easily recognized menu and, if necessary, a submenu. Examples of menu and submenu identification include, but are not limited to "Help," "System Identification," "G-S.1. Identification," or "Weights and Measures Identification."

Note: For (1.6.2.), clear instructions for accessing the information required in G-S.1. (a), (b), and (d) shall be listed on the CC, including information necessary to identify that the software in the device is the same type that was evaluated.

- 1.7. The identification badge must be visible after installation. **Yes** **No** **N/A**
- 1.8. The identification badge must be permanent. **Yes** **No** **N/A**

Code Reference: G-S.2. Facilitation of Fraud

This applies to all metering system indicators installed at a fixed location or vehicle tank meter applications and controlled remotely or within the device itself.
This requirement addresses the process of changing the unit price or unit prices set in a metering system.

- 1.9. The system shall prevent a change of unit price during a delivery. **Yes** **No** **N/A**

Code Reference: G-S.3. Permanence How would this be conducted or not?

Equipment shall be of such materials, design, and construction that, under normal service conditions:

- 1.10. Accuracy will be maintained. **Yes** **No** **N/A**
- 1.11. Operating parts will continue to function as intended. **Yes** **No** **N/A**
- 1.12. Adjustments will remain reasonably permanent. **Yes** **No** **N/A**

Code Reference: G-S.4. Interchange or Reversal of Parts

If a metering system has parts that may be interchanged or reversed in normal field assembly, the system shall either be constructed so that reversal will not affect the accuracy of the system or the parts must be marked to indicate their proper position. For most metering devices, this applies only to the reversal of connectors of cables to peripheral devices.

If a metering system has any parts that may be interchanged or reversed in normal field assembly, the parts must either be:

- 1.13. Constructed so that reversal will not affect performance, **Yes** **No** **N/A**
- 1.14. Marked or keyed to indicate their proper positions. **Multiple cable connections but not interchangeable due to different plug styles.** **Yes** **No** **N/A**
- 1.15. **Cables are connected but are not removable without breaking a seal and opening housing.** **Yes** **No** **N/A**

2. Indications, and Recorded Representations Look at different codes

Code Reference: G-S.5.1. Indicating and Recording Elements

Several general requirements facilitate the reading and interpretation of displayed values. Each display for quantity or total price must be appropriate in design and have sufficient capacity for particular applications to be suitable for the application. Metering devices must be capable of indicating the maximum quantity and money values that can normally be expected in a particular application.

- 2.1. **Minimum quantity value indications.**
- 2.1.1. Display is capable of 1.0 Yes No N/A
- 2.1.2. Display is capable of 01 Yes No N/A
- 2.1.3. Display is capable of 0.01 Yes No N/A
- 2.1.4. Display is capable of 0.001 Yes No N/A
- 2.1.5. Display is capable of other (fill in blank): Yes No N/A
- 2.2. **Money value display**
- 2.2.1. Money value is properly displayed Yes No N/A
- 3.2. **The indications must be clear, definite, and accurate.**
- 2.2.1. Values must be clear, definite, and accurate Yes No N/A
- 2.2.2. Unit of measure is programmable Gallon, Liter, Pound Yes No N/A
- 2.2.2. Unit of measure is applied by permanent marking on indicator housing Yes No N/A
- 2.3. The indications must be easily read under normal operating conditions. Yes No N/A
- 2.4. Symbols for decimal points shall clearly identify the decimal position. (Generally acceptable symbols are dots, small commas, or x.) Yes No N/A
- 2.5. **The zero indication must consist of at least the following minimum indications as appropriate:**
- 2.5.1. One digit to the left and all digits to the right of a decimal point. Yes No N/A
- 2.5.2. If a decimal point is not used, at least one active decade must be displayed. Yes No N/A
- 2.6. Totalizer values must be accurate to the nearest minimum interval with decimal points displayed or subordinate digits adequately differentiated from others, if applicable. Yes No N/A

Code Reference: G-S.5.2.2. Digital Indication and Representation

Basic operating requirements for devices:

- 2.7. All digital values of like value in a system shall agree with one another. Yes No N/A
- 2.8. A digital value coincides with its associated analog value to the nearest minimum graduation. Yes No N/A
- 2.9. Digital values shall round off to the nearest minimum unit that can be indicated or recorded. Yes No N/A
- 2.10. When a digital zero display is provided, the zero indication shall consist of at least one digit to the left and all digits to the right of the decimal point. Yes No N/A

Agreement of indications shall be checked for several deliveries. The totalizer shall be checked for accuracy and agreement with individual deliveries and with other totalizers in the system.

- 2.11. All digital values of like value in a system agree with one another. Yes No N/A
- 2.12. Digital values coincide with associated analog values to the nearest minimum graduation. Yes No N/A
- 2.13. Digital values "round off" to the nearest minimum unit that can be indicated or recorded. Yes No N/A
- 2.14. The device totalizer shall agree with the total of the individual deliveries and with other totalizers in the system. Yes No N/A

Code Reference: G-S.5.2.3. Size and Character

Digits used for comparable values must be uniform in size and character, but subordinate values may be displayed in different and less prominent digits than more significant values. The latter more likely occurs on analog devices. In digital indications, the digits are usually of uniform size throughout a particular display. The size of digits may differ for different quantities, for example, the quantity and unit price digits may be smaller than the total price digits.

- 2.15. Yes No N/A
- 2.16. Indications and recorded representations shall be appropriately portrayed or designated. Yes No N/A

Code Reference: G-S.5.2.4. Values Defined

- 2.17. Values shall be adequately defined by a sufficient number of figures, words, symbols, or combinations, which are uniformly placed so that they do not interfere with the accuracy of the reading. Yes No N/A

Code Reference: G-S.5.2.5. Permanence

- 2.18. Indications, or recorded representations and their defining figures, words, and symbols shall be of such character that they will not tend to easily become obliterated or illegible. Yes No N/A

Code Reference: G-S.5.3., G-S.5.3.1. Values of Graduated Intervals or Increments

- 2.19. Digital indications, and recorded representations shall be uniform in size, character, and value throughout any series. Quantity values shall be defined by the specific unit of measure in use. Yes No N/A
- 2.20. Indications shall be uniform throughout any series. Yes No N/A
- 2.21. Quantity values shall be identified by the unit of measure. Yes No N/A

Code Reference: G-S.5.4. Repeatability of Indications

The quantity measured by a device shall be repeatable within tolerance for the same indication. One condition that may create a problem is that the value of the quantity division may be large relative to the tolerance. A delivery must be within tolerance wherever the delivery is stopped within the nominal indication of the test draft. Meters that may be at the tolerance limit may be out of tolerance at an extreme limit of the nominal quantity indication.

- 2.22. When a digital indicator is tested, the delivered quantity shall be within tolerance at any point within the quantity-value division for the test draft. Yes No N/A

Code Reference: G-S.5.6. Recorded Representations

- 2.23. All recorded values shall be digital. (See also G-UR.3.3.) Yes No N/A

~~**Code Reference: G-S.5.7. Magnified Graduations and Indications**~~

- ~~2.24. Magnified indications shall conform to all requirements for graduations and indications. Yes No N/A~~
~~Do not think this is needed and intend on removing this section.~~

Code Reference: G-S.6. Marking, Operational Controls, Indications, and Features

All operational controls, indications, and features shall be clearly and definitely identified. Nonfunctional keys and annunciators shall not be marked because their marking implies that the key or annunciator is functional and should be inspected or tested by the enforcement official. Keys and operator controls that are visible to a customer in a direct sale transaction shall be marked with words or symbols to the extent that they can be understood by the customer and aid in understanding the transaction. Keys that are visible only to the console operator need to be marked only to the extent that a trained operator can understand the function of each key.

- 2.25. All operational controls, indications, and features including switches, lights, displays, and push buttons shall be clearly and definitely identified. Yes No N/A
- 2.26. All dual function (multi-function) keys or controls shall be marked to clearly identify all functions. Yes No N/A
- 2.27. Non-functional controls and annunciators shall not be marked. Yes No N/A

Code Reference: G-S.7. Lettering, Readability

2.28. Required markings and instructions shall be permanent and easily read. Yes No N/A

Code Reference: G-S.8. Sealing Electronic Adjustable Components, and Provision for Sealing of Adjustable Components or Audit Trail

2.29. Electronic adjustable components that affect the performance of a device shall provide for an approved means of security (e.g. data change audit trail) or for physically applying a security seal. These components include the following: Yes No N/A
(1) mechanical adjustment mechanism for meters, (2) the electronic calibration factor and automatic temperature compensator for electronic meter registers, (3) selection of pressure for density correction capability and correction values, and (4) pulser setting and gallon/liter conversion switches when they may accidentally or intentionally be used to perpetrate fraud.

The following philosophy and list of sealable parameters applies to provision for sealing all liquid-measuring devices.

An electronic data audit trail is a means of allowing a weights and measures inspector to review how many times any electronic adjustment, which affects the accuracy of a volume measurement has been changed. The information contained in the audit trail shall consist of a cumulative and non-destructible number (even if a power failure occurs) which increments each time any of the adjustments required to be sealed have been changed. The electronic data audit trail information shall be capable of being recalled by the official on the main display of the device.

As a minimum, devices which use an audit trail to provide security for sealable parameters shall satisfy the following criteria and shall use the format set forth in Appendix A of the checklist for Liquid-Measuring Devices.

Philosophy for Sealing Typical Features to be Sealed

Principles for Determining Features to be Sealed

The need to seal some features depends upon:

- The ease with which the feature or the selection of the feature can be used to facilitate fraud; and
- The likelihood that the use of the feature will result in fraud not being detected.

Features or functions which the operator routinely uses as part of device operation, such as setting the unit prices on dispensers and maintaining unit prices in price look-up codes stored in memory, are not sealable parameters and shall not be sealed.

If a parameter (or set of parameters) selection would result in performance that would be obviously in error, such as the selection of parameters for different countries, then it is not necessary to seal the selection of these features.

If individual device characteristics are selectable from a "menu" or a series of programming steps, then access to the "programming mode" must be sealable. (Note: If an audit trail is the only means of security, then the audit trail shall update only after at least one sealable parameter has been changed; simply accessing the sealable parameters via a menu shall not update the audit trail.)

If a physical act, such as cutting a wire is required to change a parameter setting and physically repairing the cut is required to reactivate the parameter, then this physical repair process would be considered an acceptable way to select parameters without requiring a physical seal or an audit trail.

Typical Features and Parameters to be Sealed

The following provides examples of configuration and calibration parameters that are to be sealed. The examples are provided for guidance and are not intended to cover all possible parameters.

Calibration Parameters: Calibration parameters are those parameters whose values are expected to change as a result of accuracy adjustments. Examples include the following.

1. Measuring element adjustments where linearity corrections are used, e.g., flow rate 1 and meter factor 1, flow rate 2 and meter factor 2, etc.
2. Mass flow meter adjustments for zero adjustments (not simply setting the display to zero) and span settings.

Configuration Parameters: Configuration parameters are those parameters whose values are expected to be entered only once and not changed after all initial installation settings are made. Examples include the following.

1. Octane or other blend setting ratios (optional in Canada at this time)
2. Temperature, pressure, density, and other sensor settings for zero, span, and offset values
3. Measurement units (in Canada, only if not displayed or printed on the primary register)
4. Temperature compensation table, liquid coefficient of expansion, or compressibility factors or tables
5. Liquid density setting (in Canada, only if not displayed or printed on the primary register) and allowable liquid density input range
6. Vapor pressures of liquids if used in calculations to establish the quantity
7. Meter or sensor temperature compensation factors
8. False or missing pulse limits for dual pulse systems (Canada only)
9. On/off status of automatic temperature, pressure, or density correction
10. Automatic or manual data input for sensors
11. Dual pulse checking feature status on or off
12. Flow control settings (optional in Canada)
13. Filtering constants

Liquid-Measuring Device Features and Parameters	
Typical Features or Parameters to be Sealed	Typical Features or Parameters Not Required to be Sealed
Measuring element adjustment (both mechanical and electronic)	Analog-to-digital converters
Linearity correction values	Quantity division value (display resolution)
Measurement units (e.g., gallons to liters)	Double pulse counting
Octane blend setting for retail motor-fuel dispensers	Communications
Any tables or settings accessed by the software or manually entered to establish the quantity (e.g., specific gravity, pressure, etc.)	
Density ranges	
Pulsers	
Signal pick-up (magnetic or reluctance)	
Temperature probes and temperature offsets in software	
Pressure and density sensors and transducers	
Flow control settings, e.g., flow rates for slow-flow start, quantity for slow-flow start and stop	
Temperature compensating systems (on/off)	
Differential pressure valves	
As a point of clarification, the flow control settings referenced above are those controls typically incorporated into the installations of large-capacity meters (wholesale meters). The reference does not include the point at which retail motor-fuel dispensers slow product flow during a prepaid transaction to enable the dispenser to stop at the preset amount.	

Note: The above examples of adjustments, parameters, and features to be sealed are to be considered "typical" or "normal." This list may not be all-inclusive. Some parameters other than those listed, which affect the metrological performance of the device, must be sealed. If listed parameters or other parameters, which may affect the metrological function of the device, are not sealed, the manufacturer must demonstrate that all settings comply with the most stringent requirements for the application of the device (i.e., the parameter does not affect compliance with Handbook 44).

Category 1 Devices (Devices with No Remote Configuration Capability):

- The device is sealed with a physical seal or it has an audit trail with two event counters (one for calibration, the second for configuration). **Yes** **No** **N/A**
- A physical seal must be applied without exposing electronics. **Yes** **No** **N/A**
- Event counters are non-resettable and have a capacity of at least 000 to 999. **Yes** **No** **N/A**
- Event counters increment appropriately. **Yes** **No** **N/A**
- The audit trail information must be capable of being retained in memory for at least 30 days while the device is without power. **Yes** **No** **N/A**
- Accessing the audit trail information for review shall be separate from the calibration mode. **Yes** **No** **N/A**
- Accessing the audit trail information must not affect the normal operation of the device. **Yes** **No** **N/A**
- Accessing the audit trail information shall not require removal of any additional parts other than normal requirements to inspect the integrity of a physical security seal. (e.g., a key to open a locked panel may be required). **Yes** **No** **N/A**

Category 2 Devices (Devices with Remote Configuration Capability but Controlled by Hardware):

- The physical hardware enabling access for remote communication must be on-site. **Yes** **No** **N/A**
- The physical hardware must be sealable with a security seal or **Yes** **No** **N/A**
- The device must be equipped with at least two event counters: one for calibration, the second for configuration parameters **Yes** **No** **N/A**
 - calibration parameters event counter
 - configuration parameters event counter
- Adequate provision must be made to apply a physical seal without exposing electronics. **Yes** **No** **N/A**
- Event counters are non-resettable and have a capacity of at least 000 to 999. **Yes** **No** **N/A**
- Event counters increment appropriately. **Yes** **No** **N/A**
- Event counters may be located either: **Yes** **No** **N/A**
 - at the individual measuring device or
 - at the system controller
- If the counters are located at the system controller rather than at the individual device, means must be provided to generate a hard copy of the information through an on-site device. **Yes** **No** **N/A**
- An adequate number (see table below) of event counters must be available to monitor the calibration and configuration parameters of each individual device. **Yes** **No** **N/A**
- The device must either: **Yes** **No** **N/A**
 - clearly indicate when it is in the remote configuration mode or
 - the device shall not operate while in the remote configuration mode.
- If capable of printing in the calibration mode, it must print a message that it is in the calibration mode. **Yes** **No** **N/A**
- The audit trail information must be capable of being retained in memory for at least 30 days while the device is without power. **Yes** **No** **N/A**
- The audit trail information must be readily accessible and easily read. **Yes** **No** **N/A**

Minimum Number of Counters Required		
	Minimum Counters Required for Devices Equipped with Event Counters	Minimum Event Counter(s) at System Controller
Only one type of parameter accessible (calibration or configuration)	One (1) event counter	One (1) event counter for each separately controlled device, or one (1) event counter, if changes are made simultaneously.
Both calibration and configuration parameters accessible	Two (2) event counters	Two (2) event counters for each separately controlled device, or two (2) or more event counters if changes are made to all controlled devices simultaneously.

Category 3 Devices (Devices with Unlimited Remote Configuration Capability):

Category 3 devices have virtually unlimited access to sealable parameters or access is controlled though a password.

- For devices manufactured after January 1, 2001, the device must either: Yes No N/A
 - Clearly indicate when it is in the remote configuration mode, or
 - The device shall not operate while in the remote configuration mode
- The device is equipped with an event logger Yes No N/A
- The event logger automatically retains the identification of the parameter changed, the date and time of the change, and the new value of the parameter. Yes No N/A
- Event counters are nonresettable and have a capacity of at least 000 to 999. Yes No N/A
- The system is designed to attach a printer, which can print the contents of the audit trail. Yes No N/A
- The audit trail information must be capable of being retained in memory for at least 30 days while the device is without power. Yes No N/A
- The event logger must have a capacity to retain records equal to ten times the number of sealable parameters in the device, but not more than 1000 records are required. Yes No N/A
- The event logger drops the oldest event when the memory capacity is full and a new entry is saved. Yes No N/A
- Describe the method used to seal the device or access the audit trail information. **Is this used?**

Code Reference: G-UR.1.1. Suitability of Equipment

A device must be properly designed and have sufficient capacity to be suitable to use in a particular application. A device must measure the appropriate characteristics of a commodity to accurately determine the quantity, have the necessary components (e.g. vapor eliminator) to eliminate factors that may cause measurement errors during normal use, have sufficient capacity to indicate the quantity measured and the associated total price if it is a computing device. The meter must have the proper flow rate capacity to operate over the actual flow rates for the application, and the device must have a quantity division appropriate for the application. Some specific requirements for device characteristics are given in the specific codes for particular devices. **Remove?**

2.24. The equipment is suitable for its intended application. **Remove?** Yes No N/A

2.25. Equipment shall be suitable for use in the environment in which it will be used. Suitability with respect to environment includes the effects of wind, weather, temperature variations, and radio frequency interference. A device must work and remain accurate under its actual conditions of use. **Unless specific tests are developed this has no meaning!** Yes No N/A

2.26. **Simulator tests: All tests shall have a minimum of 10,000 pulses applied to the device for each test. Test with a minimum of two API/Density settings. Is this appropriate for all indicator technologies PD, Mass, Mag, etc?**

Product:	Meter Factor:	K Factor:
1 Test with liquid temperature between 55 – 65 degrees F at the manufactures rated maximum frequency/pulse rate.	API Gravity/Density: Temperature:	Yes <input type="checkbox"/> No <input type="checkbox"/> N/A <input type="checkbox"/>
2 Test with liquid temperature between 55 – 65 degrees F at manufactures rated minimum frequency/pulse rate.	API Gravity/Density: Temperature:	Yes <input type="checkbox"/> No <input type="checkbox"/> N/A <input type="checkbox"/>
3 Test with liquid temperature below 35 degrees F at manufactures rated maximum frequency/pulse rate.	API Gravity/Density: Temperature:	Yes <input type="checkbox"/> No <input type="checkbox"/> N/A <input type="checkbox"/>
4 Test with liquid temperature below 35 degrees F at manufactures rated minimum frequency/pulse rate.	API Gravity/Density: Temperature:	Yes <input type="checkbox"/> No <input type="checkbox"/> N/A <input type="checkbox"/>
5 Test with liquid temperature above 100 degrees F at manufactures rated maximum frequency/pulse rate.	API Gravity: Temperature:	Yes <input type="checkbox"/> No <input type="checkbox"/> N/A <input type="checkbox"/>
6 Test with liquid temperature above 100 degrees F at manufactures rated minimum frequency/pulse rate.	API Gravity: This way or Temperature:	Yes <input type="checkbox"/> No <input type="checkbox"/> N/A <input type="checkbox"/>
7 Test with liquid temperature between 55 – 65 degrees F at the manufactures rated maximum frequency/pulse rate.	API Gravity/Density: This way Temperature:	Yes <input type="checkbox"/> No <input type="checkbox"/> N/A <input type="checkbox"/>
8 Test with liquid temperature between 55 – 65 degrees F at manufactures rated minimum frequency/pulse rate.	API Gravity/Density: Temperature:	Yes <input type="checkbox"/> No <input type="checkbox"/> N/A <input type="checkbox"/>
9 Test with liquid temperature below 35 degrees F at manufactures rated maximum frequency/pulse rate.	API Gravity/Density: Temperature:	Yes <input type="checkbox"/> No <input type="checkbox"/> N/A <input type="checkbox"/>
10 Test with liquid temperature below 35 degrees F	API Gravity/Density:	Yes <input type="checkbox"/> No <input type="checkbox"/> N/A <input type="checkbox"/>

NTEP Committee 2013 Final Report
 Appendix D – NTETC 2012 Measuring Sector Meeting Summary –
 Sub-appendix A – Agenda Item 1-Draft Checklist for Testing Electronic Digital Indicators

Product:	Meter Factor:	K Factor:
	at manufactures rated minimum frequency/pulse rate.	Temperature:
11	Test with liquid temperature above 100 degrees F at manufactures rated maximum frequency/pulse rate.	API Gravity/Density: Yes <input type="checkbox"/> No <input type="checkbox"/> N/A <input type="checkbox"/> Temperature:
12	Test with liquid temperature above 100 degrees F at manufactures rated minimum frequency/pulse rate.	API Gravity/Density: Yes <input type="checkbox"/> No <input type="checkbox"/> N/A <input type="checkbox"/> Temperature:
13		API Gravity/Density: Yes <input type="checkbox"/> No <input type="checkbox"/> N/A <input type="checkbox"/> Temperature:
14		API Gravity/Density: Yes <input type="checkbox"/> No <input type="checkbox"/> N/A <input type="checkbox"/> Temperature:
15		API Gravity/Density: Yes <input type="checkbox"/> No <input type="checkbox"/> N/A <input type="checkbox"/> Temperature:
16		API Gravity/Density: Yes <input type="checkbox"/> No <input type="checkbox"/> N/A <input type="checkbox"/> Temperature:
17		API Gravity/Density: Yes <input type="checkbox"/> No <input type="checkbox"/> N/A <input type="checkbox"/> Temperature:

Product:	Meter Factor:	K Factor:
1	Test with liquid temperature between 55 – 65 degrees F at the manufactures rated maximum frequency/pulse rate.	API Gravity: Yes <input type="checkbox"/> No <input type="checkbox"/> N/A <input type="checkbox"/> Temperature:
2	Test with liquid temperature between 55 – 65 degrees F at manufactures rated minimum frequency/pulse rate.	API Gravity: Yes <input type="checkbox"/> No <input type="checkbox"/> N/A <input type="checkbox"/> Temperature:
3	Test with liquid temperature below 35 degrees F at manufactures rated maximum frequency/pulse rate.	API Gravity: Yes <input type="checkbox"/> No <input type="checkbox"/> N/A <input type="checkbox"/> Temperature:
4	Test with liquid temperature below 35 degrees F at manufactures rated minimum frequency/pulse rate.	API Gravity: Yes <input type="checkbox"/> No <input type="checkbox"/> N/A <input type="checkbox"/> Temperature:
5	Test with liquid temperature above 100 degrees F at manufactures rated maximum frequency/pulse rate.	API Gravity: Yes <input type="checkbox"/> No <input type="checkbox"/> N/A <input type="checkbox"/> Temperature:
6	Test with liquid temperature above 100 degrees F at manufactures rated minimum frequency/pulse rate.	API Gravity: Yes <input type="checkbox"/> No <input type="checkbox"/> N/A <input type="checkbox"/> Temperature:
7	Test with liquid temperature between 55 – 65 degrees F at the manufactures rated maximum frequency/pulse rate.	API Gravity/Density: Yes <input type="checkbox"/> No <input type="checkbox"/> N/A <input type="checkbox"/> Temperature:
8	Test with liquid temperature between 55 – 65 degrees F at manufactures rated minimum frequency/pulse rate.	API Gravity/Density: Yes <input type="checkbox"/> No <input type="checkbox"/> N/A <input type="checkbox"/> Temperature:
9	Test with liquid temperature below 35 degrees F at manufactures rated maximum frequency/pulse rate.	API Gravity/Density: Yes <input type="checkbox"/> No <input type="checkbox"/> N/A <input type="checkbox"/> Temperature:

NTEP Committee 2013 Final Report
 Appendix D – NTETC 2012 Measuring Sector Meeting Summary
 Sub-appendix A – Agenda Item 1-Draft Checklist for Testing Electronic Digital Indicators

Product:	Meter Factor:	K Factor:
10	Test with liquid temperature below 35 degrees F at manufactures rated minimum frequency/pulse rate.	API Gravity/Density: Yes <input type="checkbox"/> No <input type="checkbox"/> N/A <input type="checkbox"/> Temperature: <input type="checkbox"/>
11	Test with liquid temperature above 100 degrees F at manufactures rated maximum frequency/pulse rate.	API Gravity/Density: Yes <input type="checkbox"/> No <input type="checkbox"/> N/A <input type="checkbox"/> Temperature: <input type="checkbox"/>
12	Test with liquid temperature above 100 degrees F at manufactures rated minimum frequency/pulse rate.	API Gravity/Density: Yes <input type="checkbox"/> No <input type="checkbox"/> N/A <input type="checkbox"/> Temperature: <input type="checkbox"/>
13		API Gravity/Density: Yes <input type="checkbox"/> No <input type="checkbox"/> N/A <input type="checkbox"/> Temperature: <input type="checkbox"/>
14		API Gravity/Density: Yes <input type="checkbox"/> No <input type="checkbox"/> N/A <input type="checkbox"/> Temperature: <input type="checkbox"/>
15		API Gravity/Density: Yes <input type="checkbox"/> No <input type="checkbox"/> N/A <input type="checkbox"/> Temperature: <input type="checkbox"/>
16		API Gravity/Density: Yes <input type="checkbox"/> No <input type="checkbox"/> N/A <input type="checkbox"/> Temperature: <input type="checkbox"/>
17		API Gravity/Density: Yes <input type="checkbox"/> No <input type="checkbox"/> N/A <input type="checkbox"/> Temperature: <input type="checkbox"/>

Appendix D – Sub-appendix B

Draft Measuring Element vs. Register Evaluation Criteria (Technical Policy T)

Agenda Item 1

Many different kinds of electronic indicators are available for liquid measurement. Gas pumps, vehicle tank meters, and wholesale meters are common applications used. In some cases the same indicator can be used in multiple applications. Below are some guidelines and test procedures to be incorporated into Pub 14 to allow the manufactures to pretest to and to make uniform the testing for the NTEP labs for this technology.

T. Testing required for Electronic Indicators used with Measuring Elements.

If the indicator and measuring element are built into the system as a whole device then they are approved as a system and listed as a single device on the certificate.

If the indicator or measuring element are separable and can be used with other approved and compatible equipment then the following needs to be considered:

If the Electronic Indicator and Measuring Element both have a CC then the two do not need evaluation provided new features that would have a metrological effect have not been added to the existing equipment. Even though they both have a CC they still need compatibility verification i.e. approved and compatible. This can be verified at the local level of compliance.

If neither the Electronic Indicator or Measuring Element do not have a CC then full testing will be performed as per Pub 14 permanence testing for Electronic Indicating Element (20-30 days of significant use) and Measuring Element (through put).

If the Electronic Indicator does not have a CC but the Measuring Element has a CC then the Register will go through the 20-30 day permanence test.

If the Electronic Indicator has a CC but the Measuring Element does not then the measuring element will go through the associated through put as per the permanence for that particular technology.

Upon verification of the local authority, the NTEP lab may allow the local authority to conduct one phase of the evaluation, at the NTEP labs direction and control.

Testing considerations for the electronic indicator:

- 1) Multi-point Calibration: Some of the newer indicators have the optional single point or multi-point calibration. Multi-point calibration associates multiple meter calibration factors with different flow rates. Meter field testing at the local level is usually at the maximum and minimum flow ratings of the meter. Without the ability to print or view the multi-point parameters a meter could be calibrated with an intentional erroneous factor and could go undetected. The only other way would be to test at random flow rates and depending on the number of calibration points fraud could still be undetected; i.e. a meter factor that would allow an out of tolerance error for a delivery flow rate other than customary test flow rates. Some manufactures have provided a method for weights and measures to view or print the calibration information without having to break any seals. This viewing or printing capability should be incorporated into Pub 14 (maybe HB44 too?) as a tool for W/M to be able to detect the possibility of fraud on these systems. It would also allow for manufactures to be aware of this and build this into their systems that have multi-point calibration.
- 2) Tests for temperature compensation:
 - a) Temperature test at cold temperature and verify correction.
 - b) Temperature test at hot temperature.
 - c) Temperature test at field site temperature.List temperature range tested and type of probe tested on certificate.
- 3) Tests for pulser/encoder rotation speed:
 - a) Induce pulses and/or frequency at maximum to determine limitations of device.
 - b) Induce pulses and/or frequency at minimum to determine limitations of device.List limitations on certificate.
- 4) Tests for power failure: Indicators are capable of operating on different voltages. May want to consider weighing device testing for electronic indicators and information listed on certificate.
 - a) Test through AC voltage range
 - b) Test through DC voltage range
 - c) Power failure
- 5) Tests for computation, if capable.
 - a) Test below \$.999/gal.
 - b) Test above \$1.00/gal.
 - c) Test above \$2.00/gal.
 - d) Test at maximum unit price capability.
- 6) Tests for agreement of indications between indicator and totalizer if a totalizer is provided.

Appendix D – Sub-appendix C

1991 Product Families Table Proposal – Liquid Controls (Agenda Items 2-4)

Liquid

**CONTROLS
CORPORATION**



*Attachment for
Agenda Item II
Oct, 1991*

WACKER PARK
NORTH CHICAGO, IL 60064-3702
TEL: 708 689-2400 FAX: 708 689-8090

September 23, 1991

Mr. Henry Opperman
National Institute of Stds & Tech
Administration 101 Rm A617
Gaithersburg, MD 20899

Subject: Meter Approvals - Proposed NTEP Program for Type Approval
Testing of Meters for Liquids other than Petroleum Products

Dear Henry:

As a result of our meeting on August 7, 1991 in which we discussed means for testing meters for Type Approval on liquids other than refined petroleum, I have prepared a proposal which outlines an approach that will, I believe, validate the acceptability of positive displacement meters for a large variety of liquid types and applications while holding costs and use of labor at a practical level.

Please review this and pass it along to the National Type Evaluation Technical Committee (NTETC) for discussion and action.

Your support and assistance on this matter will be greatly appreciated.

Yours truly,

Melvin C. Hankel
Manager of Engineering
Product Support Group

xc: N. Alston, NTETC Chairman
R. L. Wipple, NIST
Royal Wollberg, LC

September 23, 1991

**Proposal to NTEP:
Program for Approval of Meters on Liquids
other than Petroleum Products.**

Subject: Type Evaluation and Approval of Positive Displacement Meters for
Liquids other than Refined Petroleum Products

The use of positive displacement meters for the accurate measurement of petroleum products throughout the entire petroleum distribution system has had a long history of success.

These meters or variants of them, with minor variations of materials of construction in some cases, have the demonstrated ability to handle a wide spectrum of liquids in other areas of industry and commerce as well. Some of these applications are not familiar to many people. Therefore the ability to judge their effectiveness, especially when submitted for weights & measures type evaluation and approval for use in trade, is a cause for concern.

The response is generally to require that insitu accuracy and permanence tests be run at a field test site. This approach is cautious and conservative, but also costly to the equipment manufacturer and wasteful of Weights & Measures officials time. Indirectly, it tends to discourage use of efficient handling of liquids by meter measurement systems in many commercial areas because of protracted approval costs.

September 23, 1991

There are hundreds, even thousands, of liquids that are suitable for meter measurement. What is proposed herewith is a workable, reliable approach for evaluation that will yield results that will validate the capability of the meter on a range of liquids and conserve valuable time and labor in the process.

This approach is dependent on two general concepts:

- a) The classification of meters by materials of construction
- b)

The classification of liquids into families or groups

Materials of Construction

Classification of meters by materials of construction is as noted earlier in this proposal a means to adapt the meter to the liquid environment in which it will be used. Matters of corrosion, lubricity, and the like are dealt with by the manufacturer in order to optimize the construction for the intended service. For a given meter manufacturer, meter measuring elements in design, size, and shape are unchanged, but the materials are selected to make the unit function effectively in the liquid group in which it will be used.

Liquid Controls Corporation has developed 15 classes that give optimum performance in the various liquid groups at an effective cost level. (Refer to Appendix A for a listing of these classes.) The number and make up of the classes may vary from manufacturer to manufacturer.

Liquid Groups or Families

It is possible to classify and group liquids in a number of ways including for example the broad general groups of:

Inorganic Liquids (usually water based solutions of acids, bases, or their salts - liquids that are likely to be corrosive in varying degrees due to their dissociation or ionization in water).

or

Organic Liquids (usually non-dissociated non-ionized homogenous and non-corrosive).

However, for practical reasons in matching not only chemical characteristics, but also physical characteristics such as viscosity, vapor pressure, whether clear and homogenous, specific gravity, whether or not they contain solid particulate matter, etc. another method of classifying is desirable.

A practical classification method that has worked well in the past in the industrial metering arena uses the following Families:

Water

Hydrocarbons/Petroleum Products

Alcohols, Glycols, and water mixtures thereof

Solvents (General) Solvents

(Chlorinated) Compressed

Liquified Gases

LPG

NH₃

September 23, 1991

Agricultural Liquids

Liquid Feeds

Clear Liquid Fertilizers

Suspension Fertilizers

Herbicides

Chemicals

These are groups of liquids that have a high degree of commonality in chemical and physical properties and are therefore similar in metering characteristics.

Appendix B is a chart showing the Liquid Families along with lists of examples of the various groups and their key parameters that influence meterability. These examples cover the range of properties within a group, but the list is not inclusive of all liquids in a given group in most cases.

Appendix B also includes a chart matching meter class materials of construction with the various Liquid Families for optimum compatibility.

In view of the above, it is our specific recommendation that the following approach be used for the testing, evaluation, and approval of meters in the numerous application areas possible. We feel that this will enable expanded use in trade of a very efficient method of moving and handling liquids without undue approval cost to the manufacture nor undue use of the limited Weights and Measures labor resources:

September 23, 1991

A. Application would be made and a meter would be submitted for approval on a specific family of liquids.

From the list of liquids, constituting the family(s), two liquids representative of the high and low of the key parameters would be selected for use in the test. If the meter successfully performed on tests of accuracy and permanence on the two extreme liquids it would be approved for use on all liquids in that family(s).

B. If meters of a given class of construction successfully passed all evaluation criteria, meters of a higher grade of construction would also be granted approval if so requested at the time of application by the manufacturer if the design and size of the devices were the same. An example of this might be:

If a meter of ferrous construction were submitted and approved then the same device constructed of stainless steel could likewise be approved without retesting if so requested by the manufacturer.

C. For a given Meter Class having a range of sizes or capacities (such as 1 1/2", 2", 3", 4" and 6"), if the middle unit of these (e.g. 3") were submitted for type evaluation and passed all requirements of accuracy and permanence, then the entire series of meters would be approved if so requested by the manufacturer at the time of submittal. D. For a smaller range of size or capacity, meters one size smaller and one size larger than the meter submitted for actual approval test would be also approved upon completion of successful test of the submitted unit if the manufacturer so requested this at the time of submittal.

September 23, 1991

This is predicated on the fact that the design of the meter is identical in all respects only scaled down or up in size for capacity.

An example of this might be:

If a 2" meter were submitted for approval, upon successful completion of testing the next smaller size, 1 1/2" meter, and the next larger size, 3" meter, would likewise be given approval.

This proposal is submitted as a request to develop and establish testing policy guidelines that will enable approvals sought under NTEP to have a standardized set of procedures and requirements that are practical in terms of costs and manpower utilization.

In conclusion, in view of recent efforts to assure competitive relationships in world trade, the requirements developed for NTEP approvals of meters should be no more severe or restricting than those required by international regulatory bodies (e.g. ECC in Europe and OIML).

Melvin C. Hankel
Mgr. of Engr. Support Group
Liquid Controls Corporation

Appendix A

METER CLASSES AND MATERIALS OF CONSTRUCTION

CLASS 1 Aluminum 356-T6 NiResist II or Ryton Sintered Iron Stainless Steel BunaN	CLASS 8 316 Stainless Steel Carbon or Teflon Teflon	CLASS 16 Aluminum 356-T6 NiResist/Carbon Sintered Iron Buna Nor Teflon
CLASS 2 Aluminum 356-T6 NiResist II or Ryton Stainless Steel BunaN	CLASS 10 Aluminum 356-T6 Stainless Steel/Hardchrome NiResist/Carbon BunaN	CLASS 20 Brass Carbon 17-4PH Buna N or Teflon
CLASS 3 Aluminum 356-T6 Ni-Resist II Stainless Steel BunaN	CLASS 12 Aluminum 356-T6 Stainless Steei/Hardchrome NiResist/Carbon Teflon/Buna N	CLASS 27 Cast Iron NiResist II/Teflon Stainless Steel Viton or Teflon
CLASS 4 Aluminum 356-T6 Carbon 17-4PH Stainless 316 Stainless/Hard Chrome BunaN	CLASS 14 Aluminum 356-T6 NiResist II 316 Stainless/Hardchrome Sintered Iron Viton or Teflon	CLASS 30 Aluminum 356-T6 Teflon 316 Stainless/Hardchrome Stainless Steel Viton
CLASS 7 Cast Iron NiResist II Carbon	CLASS 15 Aluminum 356-T6 316 Stainless/Hardchrome Teflon 17-4 PH BunaN	CLASS 37 Cast Iron NiResist II Sintered Iron Viton or Teflon Stainless Steel

APPENDIX B -LIQUID COMMODITY (LIQUID FAMILY) GROUPS (AND KEY PHYSICAL PROPERTIES

LIQUID FAMILIES

CONSTRAINT	PETROLEUM PRODUCTS	SOLVENTS GENERAL	SOLVENTS CHLORINATED	ALCOHOLS GLYCOLS & WATER MIXES THERE OF	COMPRESSED LIQUIDIFIED GASES WATER		AGRICULTURAL LIQUIDS					CHEMICALS	
					LPG	NH3	FERTILIZERS CLEAR LIQUID N-P-K	FERTILIZERS NITROGEN SOLUTIONS	FERTILIZERS SUSPENSIONS	HERBICIDES	LIQUID FEEDS		
EXAMPLES OF LIQUID WITHIN FAMILIES (PARTIAL LISTING)	Diesel Fuel Distillate Gasoline Fuel Oil Mineral Spirits Oil Bunker Oil Lube Oil Crude Oil Asphalt Etc.	Acetates Acetone Esters Ethylacetate Hexane MEK Naphtha Toluene Xylene Etc.	Carbon Tetra-Chloride Methylene-Chloride Perchloro-Ethylene Trichloro-Ethylene Etc.	Ethanol Methanol Butanol Isopropyl Isobutyl Ethylene Glycol Propylene Glycol Etc.	Propane Butane Freon 11 Freon 12 Freon 22 Etc.	Anhydrous-Ammonia	Tap Water Deionized Demineral-ized Potable	10-34-0 4-10-10 9-18-9 Etc.	20% Aqua-Ammonia 28%,30% or 32% Nitrogen Solution Urea Ammonia-Nitrate Etc.	3-10-30 4-4-27 Etc.	Atrex Atrazine Bicep Bladex Dual Eptan Eradicane Lorax Princep Round-up Sencor Sutan Treflon Etc	Liquid-Molasses + Phos-Acid and/or Urea Etc.	Surfamic-Acid Hydrochloric-Acid Phosphoric-Acid Etc.
VISCOSITY SSU	25 to 1 Million	2 to 35	2 to 35	2 to 35	.5 to 3	.5	5	50 to 150	30 to 100	100 to 1000	100 to 3500	50 to 250,000	75
CP		0.3 to 7	0.3 to 7	0.3 to 7	.1 to .5	.1	1.0	10 to 30	10 to 30	20 to 200	20 to 700	10 to 50,000	
SP.GR.	.68 to 1.1	.6 to 1.6	.6 to 1.6	.6 to 1.6	.5 to .65	.56 to .68	1.0	1.0 to 1.3	1.0 to 1.35	1.0 to 1.65	.9 to 1.2	1.2 to 1.5	1.1 to 1.85
% OF ABRASIVE SOLIDS	None	None	None	None	None	None	None	None	None	4%	3%	4%	None
LUBRICITY SERVICE FACTOR	1.0	1.0	1.0	1.0	1.0	1.0	1.0	1.0	1.0	0.8	0.8	0.8	1.0
RANGE	10:1	10:1	10:1	10:1	5:1	5:1	10:1	10:1	10:1	8:1	8:1	8:1	10:1
CLASS													
1	X												
2	X												
3													
4							X						
7	X	X	X	X									
8	X	X	X	X			X	X	X		X	X	X
10					X								
12						X							
14												X	
15									X		X		
16		X		X									
20							X						
27								X	X		X		
30											X		
37	X							X		X		X	

Appendix D/ Sub-appendix D

1991 PD Meters TP 101D – Smith Meter Inc.

(Agenda Item 2-4)

Smith Meter Inc.

A Moorco Company



Positive Displacement Liquid Meters

Christopher B. Laird

Introduction

This paper will examine positive displacement (P.D.) meters for liquid measurement. The emphasis will be on providing a basic understanding of the factors influencing its design and performance. Although the focus will be on petroleum liquids, these factors can be applied to other applications and other liquids as well.

History

P.D. meters have existed for over a century. Many of the designs were developed from either pumps or compressors. By the late 1930's, P.D. meters were being used extensively for precise measurement of petroleum liquids on tank trucks, bulk loading terminals, and small pipelines. With the construction of large pipelines and large ship loading facilities in the 1950's and 1960's, P.D. meters were developed which could measure flow rates over 10,000 barrels per hour. Most will agree that since its perfection in the 1950's, there exists no more accurate means of petroleum measurement than the P.D. meter. It has become the "Standard of Measurement" for the liquid petroleum industry.

Types of Meters

In general, all types of fluid flow meters can be classified as either Inference or Direct type meters.

Inference

Inference meters infer volumetric flow rate by measuring some dynamic property of the flow stream. Turbine meters fall into this category.

Other examples of Inference meters are orifice plates, flow nozzles, venturis, and pilot tubes, all of which infer flow rate from differential pressure measurements. Other types of meters infer flow rate from the measurement of mechanical force, magnetic resonance, flow area, electromagnetic force, speed of sound, vortex shredding, drag, swirl, impeller speed, etc.

One basic assumption of all Inference meters is that the effective flow cross-sectional area at the meter sense point remains constant between meter provings. If this effective flow area changes due to erosion, corrosion, deposits, boundary layer thickening, cavitation, obstructions, etc., the volume registration will change even though volumetric flow rate remains constant.

Direct

P.D. meters are of the Direct type since they measure volumetric flow directly by continuously separating (isolating) the flow stream into discrete volumetric segments and counting them.

Within the last few years, another interesting meter has emerged. It is the vibrating tube mass meter, and it

Technical Paper 101D

responds directly to mass flow; and, therefore, is of the Direct type.

Design and Construction

The three basic groups of components or subassemblies that make up a P.D. meter are the: External Housing, Internal Measuring Element, and Accessory Drive Train.

External Housing

The external housing is basically a pressure vessel with inlet and outlet connections. P.D. meters are commonly built with inlet and outlet connections from 1/4" to 16" for pressures to 1,440 psi (600 lb ANSI) and flow rates to 12,500 BPH. External housing materials typically are carbon steel, cast iron, ductile iron, aluminum, bronze, or stainless steel.

Meters may be of single or double case construction. In single case construction, the external housing serves both as a pressure vessel and as the measuring element housing; whereas with double case construction, the external housing is strictly a pressure vessel. Small meters of materials other than carbon steel are normally single case. Meters over 6" in size almost always use carbon steel double case construction.

The advantages of double case construction are: (1) piping stress is not transmitted to the measuring element; (2) the measuring element can be easily removed for service or line flushing on start-up; and (3) the differential pressure across the measuring element walls is minimal, thus eliminating the possibility of measuring element dimensional changes due to system pressure variations.

Internal Measuring Element

As previously mentioned, P.D. meters measure volumetric flow by continuously separating the flow stream into discrete volumetric segments and counting them. Some of the most common P.D. meters measuring element principles are illustrated in Figure 1. The measuring element also serves as a hydraulic motor, absorbing energy from the flow stream to produce the torque necessary to overcome internal friction and drive the counter and other accessory loads.

Accessory Drive Train

The accessory drive train, a typical example of which is shown in Figure 2, consists of three basic elements; Gear Train, Rotary Shaft Seal (Packing Gland), and Calibrator (Adjustor).

1. Gear Train

The gear ratio of the gear train is chosen to convert the fixed volume per revolution of the measuring element to some nominally convenient volume per revolution of the counter input shaft. For example, a 4" Smith P.D. Meter measuring element has a nominal 2.0 Gal/Rev. A typical counter input shaft speed

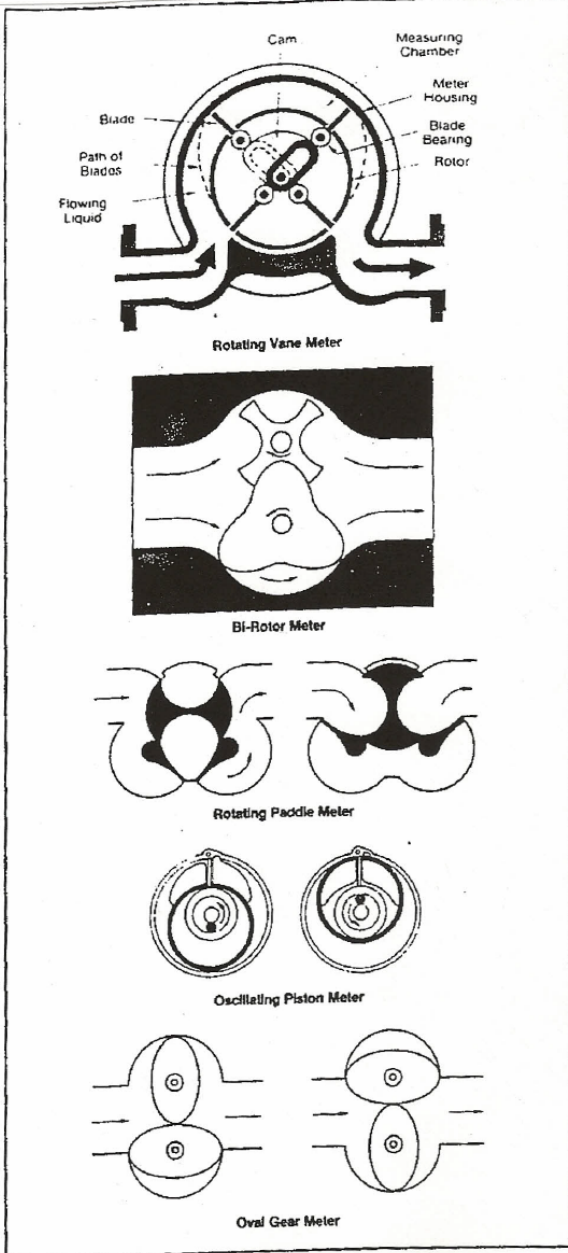

Figure 1 — P.D. Meter Measuring Elements

utilized is 5 Gal/Rev. Thus, a nominal 5:2 reduction gear ratio is used for the meter gear train.

2. Rotary Shaft Seal

A rotary shaft seal is required where the counter drive train penetrates the meter pressure vessel. It is normally designed into a module or gland for easy access, since it is a wear item which must be serviced when leakage occurs.

Smith's high pressure (275 psi and up) meters utilize an externally lubricated packing gland to isolate the dynamic shaft seal from the product, thereby increasing packing gland life. The external lubricant (typically glycerin or silicone grease) must be chemically compatible and immiscible with the product being metered.

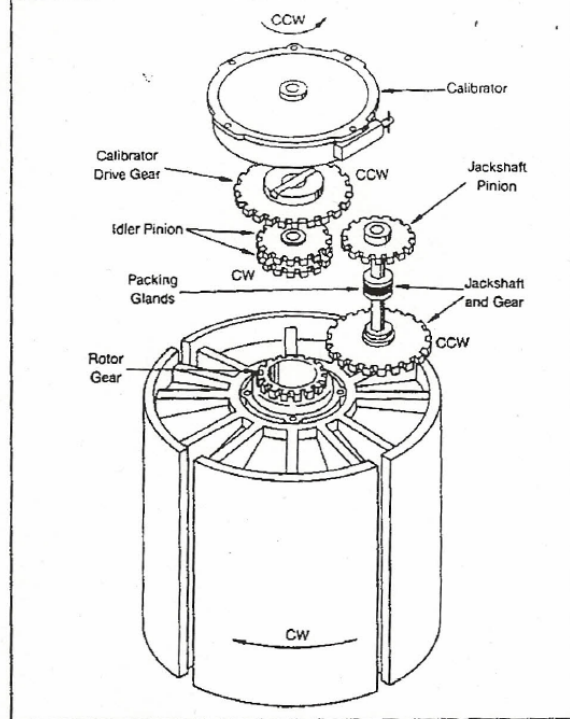

Figure 2 — Typical Counter Drive Train

Some P.D. meters have a magnetic drive coupling instead of a packing gland to eliminate the need for frequent servicing of a dynamic shaft seal.

The primary factors affecting rotary shaft seal life are the seal's compatibility with the liquid and the abrasive contamination of the liquid.

3. Calibrator (Adjustor)

A meter calibrator is a device for adjusting in fine increments the meter's counter drive train to register the true volume that has passed through the meter. Without a calibrator, a meter can typically only be geared to register true volumetric throughput within about 0.5 - 1.0%. This is due to manufacturing variations in the measuring element and the relatively coarse gear ratio increments available in a normal meter gear train.

Thus, a calibrator is necessary whenever the mechanical counter on the meter must register actual volume throughput. If a "meter factor" (ratio of actual/registered volume) is to be applied to registered volume, a common practice with pipeline meters, then nominal 100% meter gearing and no calibrator or a "dummy calibrator" is typically used.

Characteristics of a good meter calibrator are:

- Ability to drive a high torque load.
- Long service life.
- Fine adjustment range.
- Adequate adjustment range.
- Low repair or replacement cost.
- Minimal cyclic speed variation of the output shaft.

No available meter calibrator rates superior in all of these categories. However, the commonly used clutch type calibrator probably has a superior rating for all except minimal cyclic speed variation.

Since the clutch calibrator can only add revolutions to its input shaft, it is necessary that the gear train be biased slightly to under-register the throughput volume. Thus, when a 4" Smith P.D. Meter is said to have "96% 5:1 gallon gearing," the nominal gear ratio to the calibrator is only 96% of 5 U.S. gallons per revolution (4.8 U.S. gallons/rev). The calibrator must be adjusted to the overall gear ratio to the counter or other accessories by approximately 4%.

The clutch calibrator incorporates a double overriding clutch mechanism which acts to increase the drive ratio, e.g., 96 revolutions in 100 revolutions out. This is accomplished by increasing the speed of the input shaft through one-half of each output shaft revolution. That is, through the first half revolution, the input and output shafts travel at the same speed; however, during the second half revolution, the output shaft speeds above (overrides) the input shaft (upper graph of Figure 3). This produces cyclical speed variations in the output shaft. The amount of speed variation is proportional to the amount of calibration being applied.

Cyclic speed variation from a calibrator causes no registration error when the volume delivered is a whole number multiple of the volume per calibrator output shaft revolution. For example, a meter geared 5 gallons per calibrator output shaft revolution would have no registration error if the volume delivered were an exact multiple of 5 (e.g., 15, 605, 1,000, etc.) gallons. Since the volume of a tank or can type prover vessel is normally such a whole number multiple of the meter's volume per revolution, meter calibration is generally unaffected by cyclic speed variation from a calibrator.

However, the volume between detector switches on a pipe (displacement type) prover is normally not exactly a whole number multiple of the meter volume per revolution. Thus, cyclic speed variation from the calibrator can cause nonrepeatability in consecutive pipe prover type meter calibration tests.

Since the nonrepeatability is strictly random, statistical averaging of the results from several consecutive tests will produce an accurate meter factor.

In order to understand why cyclic speed variations from the calibrator can cause nonrepeatability when proving the meter, the operation of the calibrator must be closely examined. The lower graph in Figure 3 shows how the calibrator output shaft alternates in error between +4% or -4%.

If the meter were proved on only one-half (1/2) revolution of the calibrator (2-1/2 gallons on a 96% 5:1 gallon geared meter), then the repeatability error would be ±4% as shown by Case A.

If the meter were proved on one revolution (or whole revolutions) of the calibrator then there would be no repeatability error as shown by Case B.

$$\text{Repeatability Error (\%)} = \frac{(1 - \text{Nom. Meter Gearing})}{(2 \times \text{Revs. of Calibration Output Shaft})}$$

For a meter having nominal 99% 5:1 gallon gearing, an approximate 500 gallon calibration run would have a negligible (1%/200 = 0.005%) repeatability error. However, if the meter were geared 96% 1:1 barrel (one barrel per rev.), the maximum possible error on the above calibration run would be substantial (4%/2(500/42) = 0.17%). Thus, to minimize nonrepeatability of calibration runs when a cyclic output calibrator is to be used on a meter to be calibrated with a pipe prover, the meter should be geared for minimum calibrator correction

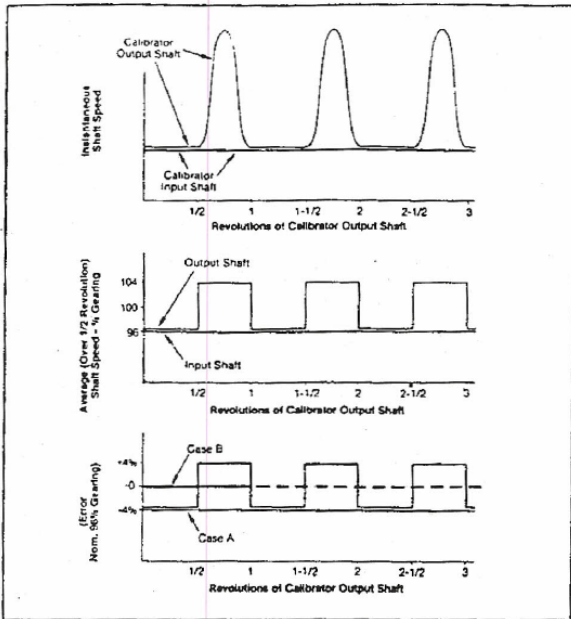

Figure 3 — Revolutions of Calibrator Output Shaft

(e.g., 99%) and maximum calibrator output shaft revolutions (smallest possible units of measure).

Cyclic speed variation can come from other sources. As liquid flows through the meter at a steady rate, the measuring element rotates. This rotation is carried through the drive train to eventually turn a counter, pulse transmitter, etc. It is logical to expect that if the liquid flow rate is constant, then the rotational speed of the output shaft must also be constant. This is not necessarily the case. As mentioned previously, a clutch calibrator will induce a cyclic speed variation in the output shaft.

However, even if a "dummy" calibrator is used, there will be small cyclic speed variation in the output shaft. Unlike the calibrator, this speed variation does not repeat (cycle) on each revolution of the shaft. It may not repeat for several revolutions. This is the result of rotor runout, gear runout, and drive couplings, and even though the speed variation is small, it can cause nonrepeatability when the meter is being proved using small volume displacement provers.

These secondary sources of cyclic speed variation are peculiar to each individual meter and, therefore, cannot be accurately predicted. In some cases, they may act to cancel each other or they may add to each other. If the nonrepeatability which is caused by these factors is excessive, then larger groups of proving runs can be taken and the repeatability of consecutive groups can be evaluated.

Accuracy Theory

The factors affecting the performance of P.D. meters can be described in terms of their effect on the volume displacement per rotor revolution or the slippage through the clearances of the measuring element.

Volume Displacement

The volume displaced by the measuring element is affected by: temperature, pressure, viscosity, wear, and deposits.

1. Temperature

Increasing temperature causes the measuring chamber volume to expand at the cubical expansion coefficient of its metal parts. When dissimilar metals are used (e.g., aluminum blades in a cast iron measuring element), the clearance between the dissimilar metal parts (e.g., blade tip clearance) changes with temperature, affecting displacement volume. This temperature effect is typically about 0.02% for a 10° F fluid temperature change.

2. Pressure

A substantial change in operating pressure will affect displacement volume in a single case meter, but not in a double case meter (where the pressure differential across the walls of the measuring chamber is nil). This effect varies with meter design. However, as a guideline, where operating pressure changes of over 20 psi are expected, the use of either a double case meter or a pressure adjusted meter factor should be considered.

3. Viscosity

As the viscosity of the liquid increases, it tends to cling to the surfaces of the measuring chamber. This clingage has the effect of reducing the displacement volume. This reduction ends when the film can no longer build because of the wiping action of the parts forming the measuring chamber.

4. Wear

Wear can have the effect of increasing the displacement of the rotating vane meter. As the cam or blade bearing becomes worn, the blade is allowed to move closer to the inner surface of the measuring chamber and, therefore, displaces more volume.

5. Deposits

Deposits such as paraffin on measuring chamber surfaces will reduce displacement volume up to a point where clearances become nil. Then, meter performance should remain very constant as long as the deposit remains in place.

However, if the paraffin has a melting point near the operating temperature of the meter, then the formation or melting can cause significant shifts in meter performance.

Slippage

All P.D. meters have some clearances between moving and stationary surfaces, with differential pressure across the clearances. Thus, there will always be some fluid that bypasses the measuring chamber by "slipping" through these clearances.

Figure 4 shows a typical clearance and the following equation relating the factors affecting slippage.

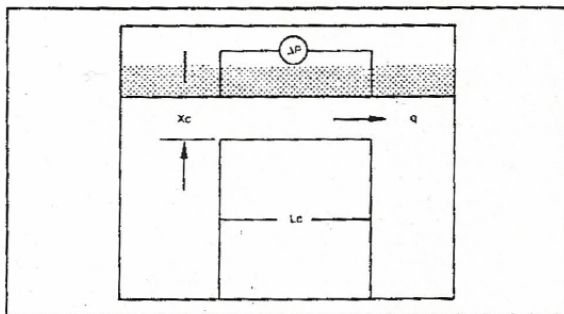

Figure 4 — Typical P.D. Meter Clearance

$$q = K \frac{Xc^3}{\mu Lc} \Delta P$$

If % bypass ($q/Q \times 100$) remained constant, the counter gear train could be adjusted to compensate for it. However, this relationship does not remain constant under normal operating conditions because of the following factors:

1. Viscosity

Figure 5 is a typical illustration of how the accuracy curve shifts with changing viscosity.

It is interesting to note that the rangeability of a P.D. meter increases dramatically with increasing viscosity. An approximate "rule of thumb" is that a meter's rangeability for a given meter factor shift, as well as meter factor shift for a given rangeability, changes in direct proportion to the change in fluid absolute viscosity (e.g., centipoise, but not necessarily SSU). For example, a P.D. meter should have about the same linearity accuracy between 5% and 100% of maximum rated flow (rangeability of 20:1) on a 4 cP viscosity fluid as it has between 10% and 100% of maximum rated flow (rangeability of 10:1) on a 2 cP viscosity fluid. In other words, halving the viscosity also halves the rangeability.

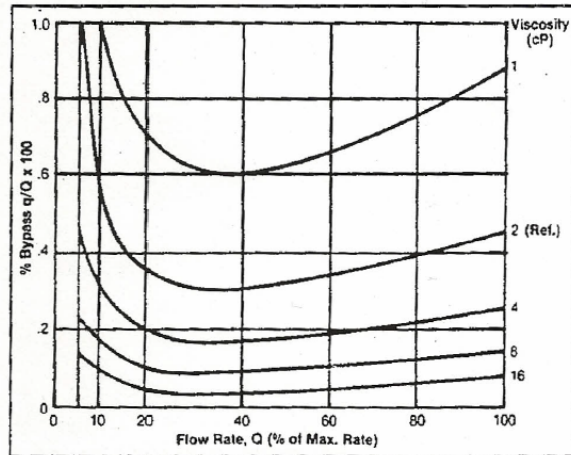

Figure 5 — Typical P.D. Meter Accuracy Curve Shift with Viscosity

It is also interesting to note in Figure 5 the relative shift in % bypass (or meter factor) with viscosity. At viscosities greater than 16 cP, the change in meter factor with changing viscosity and flow rate is negligible for this meter between 10% and 100% of maximum rated flow. In general, from an accuracy viewpoint at least, P.D. meters are the ideal flow meter for fluid viscosities greater than about 4 cP (No. 2 Fuel Oil or 40° API gravity crude oil). The accuracy and rangeability of Inference type flow meters (e.g., turbine meters), in general, decrease at higher viscosities, opposite to that of P.D. meters.

The viscosity of most liquids is related to the temperature. Figure 6 shows several relationships. For example, the viscosity of kerosene changes from 2.6 cP to 1.3 cP between 40° F and 100° F, respectively

2. Clearances

Figure 7 is a typical illustration of how the accuracy curve can shift with a relatively small change in average measuring element clearances (Xc). This shift is due to the cubing of this term in the basic bypass equation (Equation 2).

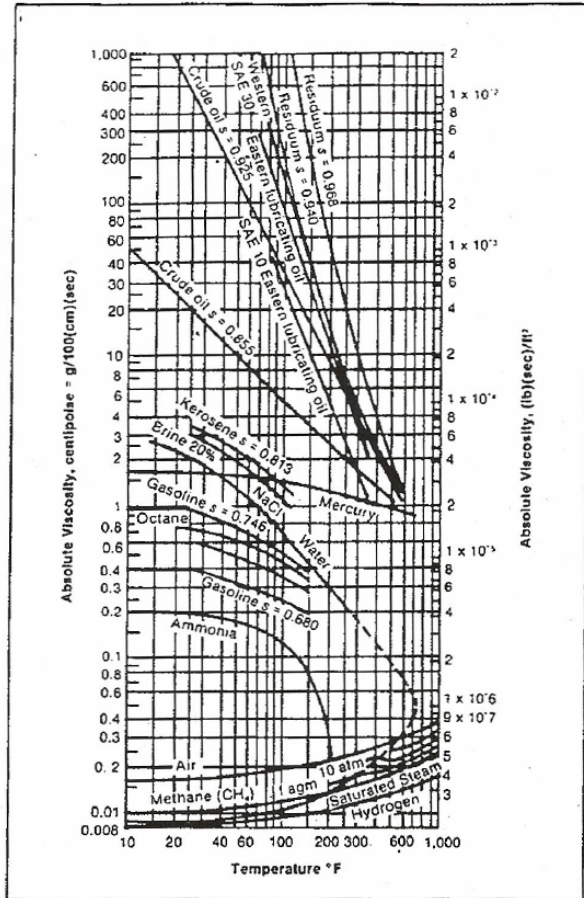

Figure 6 — Values of Absolute Viscosity

From an economical manufacturing viewpoint, because of the buildup of manufacturing tolerances in the various components of the measuring element of a P.D. meter, it is virtually impossible for all P.D. meters of the same design to have exactly the same clearance dimensions. Thus, any two apparently identical P.D. meters can exhibit significantly different shifts in meter factor even though the service

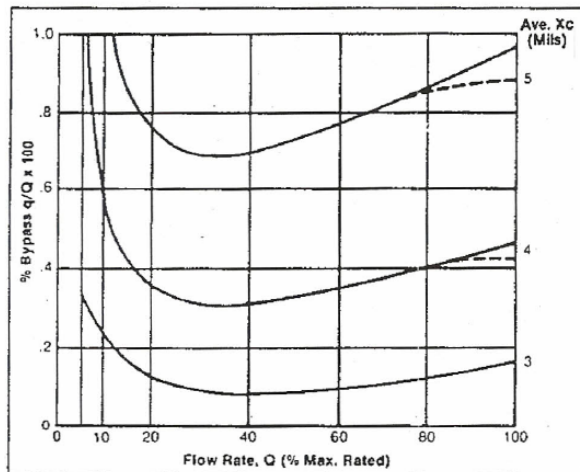

Figure 7 — Typical P.D. Meter Accuracy Curve Shift with Clearance Width

would appear to be identical. Certainly the tighter the meter clearances, the less the slippage and the lower the meter factor shift. However, a meter with extremely tight clearances will have reduced service time before inevitable bearing wear causes these same clearances to close up altogether, subsequently resulting in increased mechanical friction and possible severe meter element damage.

3. Friction

Figure 8 shows how the accuracy curve is shifted due to change in mechanical friction. When mechanical friction increases, more pressure differential is required to produce the torque to drive the meter, and therefore, bypass through the clearances is greater. Meters with relatively high mechanical friction may actually show better linearity over a narrow range (e.g., 2:1).

Accuracy Maintenance

In general, if liquid and operating properties (e.g., viscosity, flow rate, temperature) remain constant, there are only two basic types of meter malfunctions that can cause an abnormal shift in meter factor: excessive meter clearances, or excessive mechanical friction.

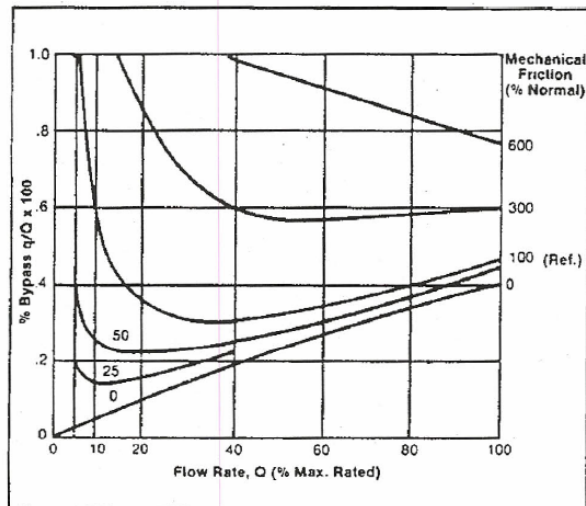

Figure 8 — Typical P.D. Meter Accuracy Curve Shift with Mechanical Friction

Observing the shift in meter factor at low and high flow rates, from earlier calibration runs, particularly on light viscosity (<10 cP) liquids, can provide a clue as to which of these two possible malfunctions is the cause of the problem. In both cases, the meter factor will increase. However, in comparing Figures 7 and 8, one observes that excessive meter clearances result in a greater increase in meter factor at high flow (e.g., 100%) than at low flow (e.g., 20%), whereas the opposite is true for excessive mechanical friction. If the latter is thus indicated, it is advisable to first check the torque required to drive the accessory stack. It is not uncommon for corrosion, abrasion, or foreign matter in a meter stack to cause its required drive torque to increase significantly.

Loss of rotor end clearance is another common cause of meter factor shift in horizontal meters. This has the compounding effect of increasing slippage through the upper rotor end clearances and increasing slippage through all clearances due to the high friction load.

Figure 8 shows another interesting phenomenon for very low mechanical friction. Notice the hypothetical 0% mechanical friction curve has more slippage at 100% of flow rate than at others. This is due to hydraulic pressure drop as liquid passes through the meter.

Conclusion

For optimum metering accuracy, it is important for the P.D. meter user to have a basic understanding of how various design and operating conditions can affect P.D. meter performance. This paper should provide that basic understanding.

The P.D. meter design characteristics important to good meter accuracy are:

- Low pressure differential across measuring element clearances.
- Large clearance length L_C .
- Small clearance width, X_C .

The low pressure differential across meter clearances is the main reason for the good accuracy characteristics of the Smith P.D. Meter. This is primarily the result of the following basic design characteristics of the Smith P.D. Meter:

1. At high flow rates, most of the pressure drop across the meter occurs in the inlet and outlet nozzles and not directly across the measuring element.
2. At low flow (less than 10%), the main cause of pressure drop is the energy expended to overcome internal friction (turn the meter) and the accessory torque load. In the Smith meter, this pressure drop is low because of the use of low friction ball bearings, the relatively large extended blade area normal to the flow stream, and the relatively large moment arm of the extended blade.

The operating condition variations having the greatest effect on the gross meter factor of a P.D. meter are: flow rate, fluid, viscosity, and fluid temperature.

P.D. meters, in general, provide better accuracy than velocity type meters (e.g., turbine meters) for applications where fluid viscosity exceeds about 4 cP (e.g., No. 2 Oil). Fluid viscosity may change due to temperature variations with the same fluid or due to a change of fluids. The insensitivity of the P.D. meter's meter factor to changes in operating conditions increases with increasing fluid viscosity. The opposite is true for velocity type meters.

For flow rates greater than about 4,000 BPH (10" P.D. meter), the cost of P.D. meters normally substantially exceeds the cost of alternative measurement methods (e.g., turbine meters).

However, this extra cost can be quickly offset by the superior accuracy obtainable from the P.D. meter. For example, a 16" P.D. meter operating at its maximum flow rate registers over \$200,000 worth of liquid per hour. An increase in accuracy of only 0.02%, would pay for itself at the rate of nearly \$1,000 per day.

References

1. Streeter, Victor L.: "Handbook of Fluid Dynamics," McGraw-Hill, New York, 1961.
2. Streeter, Victor L.: "Fluid Mechanics," 2nd Edition, McGraw-Hill, New York, 1958.

Acknowledgement

Much of the material presented here is contained in Smith Meter Inc. Technical Paper 101B, written by Philip D. Baker.

THIS PAGE INTENTIONALLY LEFT BLANK

Appendix D/Sub-appendix E

Technical Policy C – Product Families Table – Centistoke Correction – (Agenda Item 9)

C. Product Categories and Families for Meters

When submitting a meter for evaluation, the manufacturer must specify the product category(y)(ies) and/or family(y)(ies) and critical parameters for which the meter is being submitted.

Product Category

A group of products that share similar characteristics.

Note: Under certain Test Requirements, product coverage is indicated by reference to the "Product Category," while under other Test Requirements, product coverage is indicated by "Product Family."

Product Family

A group of products, sometimes including multiple Product Categories, which share a common Test Requirement.

Note: Coverage of different products by a certificate may be indicated using references to either "Product Categories" or "Product Families," as indicated in the Test Requirement for that Product Family.

The product family and the specific product subgroup covered by the Certificate are to be identified on page one (1) of the Certificate of Conformance. More detailed information, including the typical product types found in the subgroup is to be included in the application section of the Certificate.

THIS PAGE INTENTIONALLY LEFT BLANK

Mass Meter Product Category and Test Requirements			Magnetic Flow Meter Product Category and Test Requirements			Positive Displacement Flow Meter Product Category and Test Requirements		Turbine Flow Meter Product Category and Test Requirements	
Test B To cover a range of the following products, test with one product having a low specific gravity and test with a second product having a high specific gravity. The Certificate of Conformance will cover all products in all product categories listed in the table under Test B within the specific gravity range tested. <ul style="list-style-type: none"> • Test B does not apply to product categories of liquefied gases, compressed liquids, cryogenic liquids or heated products. <i>Note: Product categories under Test B were formerly referred to collectively as "Normal Liquids."</i>			Test F To cover a range of the following products, test with one product having a specified conductivity. The Certificate of Conformance will cover all products with conductivity equal to or above the conductivity of the tested liquid. <ul style="list-style-type: none"> • Test F does not apply to product categories of potable water, non-potable water, tap water, water mixes of alcohols and glycols, fertilizers, suspension fertilizers, liquid feeds, clear liquid fertilizers, chemicals or crop chemicals A, B, C, or D. • Test F does not apply to product categories of liquefied gases, or compressed liquids. 			Test C To cover a range of products within each product category, test with one product having a low viscosity and test with a second product having a high viscosity within each category. The Certificate of Conformance will cover all products in the product category within the viscosity range tested.		Test E To cover a range of products within each product category, test with one product having a low kinematic viscosity and test with a second product having a high kinematic viscosity within each category. The Certificate of Conformance will cover all products in the product category within the kinematic viscosity range tested. ¹	
						Product Category: Alcohols, Glycols and Water Mixes Thereof (Alc Gly)		Product Category: Alcohols, Glycols and Water Mixes Thereof (Alc Gly)	
Typical Products	Specific Gravity ² (60 °F)	Product Category	Typical Products	Conductivity (micro-siemens/centimeter)	Product Category	Typical Products	Reference Viscosity ¹ (60 °F) centipoise (cP)	Typical Products	Reference Kinematic Viscosity ¹ (60 °F) centistokes (cSt)
Butanol	0.81	Alc Gly	Butanol		Alc Gly	Butanol	3.34	Butanol	4.13
Ethanol	0.79	Alc Gly	Ethanol	0.0013	Alc Gly	Ethanol	1.29	Ethanol	1.64
Ethylene Glycol	1.19	Alc Gly	Ethylene Glycol		Alc Gly	Ethylene Glycol	25.5	Ethylene Glycol	21.5
Isobutyl	0.81	Alc Gly	Isobutyl	0.02	Alc Gly	Isobutyl	4.54	Isobutyl	5.62
Isopropyl	0.79	Alc Gly	Isopropyl	3.5	Alc Gly	Isopropyl	2.78	Isopropyl	3.53
Methanol	0.80	Alc Gly	Methanol	0.44	Alc Gly	Methanol	0.64	Methanol	0.80
Propylene Glycol	1.04	Alc Gly	Propylene Glycol		Alc Gly	Propylene Glycol	54	Propylene Glycol	52
Banvel	0.7 – 1.2	CC-A	6 Oil (#5, #6)		FL&O	Test C Product Category: Crop Chemicals (Type A) (CC-A)		Test E Product Category: Compressed Liquids, Fuels and Refrigerants NH ₃ (Comp liq)	
Herbicides	0.7 – 1.2	CC-A	Asphalt		FL&O	Typical	Reference Viscosity ¹	Typical	Reference Kinematic

¹ Viscosity (dynamic) is measured in centipoise. Kinematic viscosity is measured in centistokes. Source for some of the viscosity value information is the Industry Canada – Measurement Canada "Liquid Products Group, Bulletin V-16-E (rev.1), August 3, 1999."

$$\text{centistokes (10}^{-6} \text{ m}^2/\text{s)} = \text{centipoise (10}^{-3} \text{ kg/m}\cdot\text{s)} \div \text{density (kg/m}^3) \quad \text{OR} \quad \text{centistokes (cSt)} = 1.002 \times \text{centipoise (cP)} \div \text{density (SG)}$$

² The specific gravity of a liquid is the ratio of its density to that of water at standard conditions, usually 4 °C (or 40 °F) and 1 atmosphere. The density of water at standard conditions is approximately 1000 kg/m³ (or 998 kg/m³). The specific gravity of a gas is the ratio of its density to that of air at standard conditions, usually 4 °C (or 40 °F) and 1 atmosphere.

Mass Meter Product Category and Test Requirements			Magnetic Flow Meter Product Category and Test Requirements			Positive Displacement Flow Meter Product Category and Test Requirements		Turbine Flow Meter Product Category and Test Requirements	
						Products	(60 °F) centipoise (cP)	Products	Viscosity ¹ (60 °F) centistokes (cSt)
Paraquat	0.7 – 1.2	CC-A	Avgas		FL&O	Banvel	4 – 400	Anhydrous Ammonia	0.31
Typical Products	Specific Gravity ² (60 °F)	Product Category	Typical Products	Conductivity (micro-siemens/centimeter)	Product Category	<u>Test C</u> Product Category: Crop Chemicals (Type A) (CC-A) continued		<u>Test E</u> Product Category: Compressed Liquids, Fuels and Refrigerants NH ₃ (Comp liq) continued	
Prowl	0.7 – 1.2	CC-A	Biodiesel above B20		FL&O	Typical Products	Reference Viscosity ¹ (60 °F) centipoise (cP)	Typical Products	Reference Kinematic Viscosity ¹ (60 °F) centistokes (cSt)
Round-up	0.7 – 1.2	CC-A	Bunker Oil		FL&O	Herbicides	4 – 400	Butane	0.32
Touchdown	0.7 – 1.2	CC-A	Cooking Oils		FL&O	Paraquat	4 – 400	Ethane	
Treflan	0.7 – 1.2	CC-A	Corn Oil		FL&O	Prowl	4 – 400	Freon 11	0.21
Adjuvants	0.7 – 1.2	CC-B	Crude Oil		FL&O	Round-up	4 – 400	Freon 12	0.27
Fumigants	0.7 – 1.2	CC-B	Diesel Fuel ³		FL&O	Touchdown	4 – 400	Freon 22	1.46
Fungicides	0.7 – 1.2	CC-B	Fuel Oil (#1, #2, #3, #4)	0	FL&O	Treflan	4 – 400	Propane	0.195
Insecticides	0.7 – 1.2	CC-B	Gasoline ⁴		FL&O	<u>Test C</u> Product Category: Crop Chemicals (Type B) (CC-B)		<u>Test E</u> Product Category: Fuels, Lubricants, Industrial and Food Grade Liquid oils (FL&O)	
Fungicides	1 – 1.2	CC-C	Jet A		FL&O	Typical Products	Reference Viscosity ¹ (60 °F) centipoise (cP)	Typical Products	Reference Kinematic Viscosity ¹ (60 °F) centistokes (cSt)
Micronutrients	0.9 – 1.65	CC-D	Jet A-1		FL&O	Adjuvants	0.7 – 100	6 Oil (#5, #6)	73 – 14,500
Hydrochloric Acid	1.1	Chem	Jet B		FL&O	Fumigants	0.7 – 100	Asphalt	
Phosphoric Acid	1.87	Chem	JP4		FL&O	Fungicides	0.7 – 100	Avgas	
Sulfuric Acid	1.83	Chem	JP5		FL&O	Insecticides	0.7 – 100	Biodiesel above B20	11.8
3-10-30	0.9 – 1.65	Fert	JP7 and JP8		FL&O	<u>Test C</u> Product Category: Crop Chemicals (Type C) (CC-C)		Bunker Oil	11,300
4-4-27	0.9 – 1.65	Fert	Kerosene		FL&O	Typical Products	Reference Viscosity ¹ (60 °F) centipoise (cP)	Cooking Oils	10.8
9-18-9	1.32	Fert	Light Oil		FL&O	Fungicides	20 – 900	Corn Oil	4.4
10-34-0	1.39	Fert	Lubricating		FL&O	<u>Test C</u>		Crude Oil	3 – 2260

NTEP - D / E4

³ Diesel fuel blends (biodiesel with up to 20% vegetable or animal fat/oil.)

⁴ Gasoline includes oxygenated fuel blends with up to 15% oxygenate.

Mass Meter Product Category and Test Requirements			Magnetic Flow Meter Product Category and Test Requirements			Positive Displacement Flow Meter Product Category and Test Requirements		Turbine Flow Meter Product Category and Test Requirements	
			Oils			Product Category: Crop Chemicals (Type D) (CC-D)			
20% Aqua-Ammonia	0.89	Fert	Olive Oil		FL&O	Typical Products	Reference Viscosity ¹ (60 °F) centipoise (cP)	Diesel Fuel ³	12
28%, 30% or 32%	1.28 – 1.32	Fert	Peanut Oil		FL&O	Micronutrients	20 – 1000	Fuel Oil (#1, #2, #3, #4)	9 – 98

Typical Products	Specific Gravity ² (60 °F)	Product Category	Typical Products	Conductivity (micro- siemens/centimeter)	Product Category	Test C		Test E	
						Product Category: Chemicals (Chem)		Product Category: Fuels, Lubricants, Industrial and Food Grade Liquid oils (FL&O) continued	
Ammonia Nitrate	1.16 – 1.37	Fert	SAE Grades		FL&O	Typical Products	Reference Viscosity ¹ (60 °F) centipoise (cP)	Typical Products	Reference Kinematic Viscosity ¹ (60 °F) centistokes (cSt)
Clear Liquid Fertilizer	1.17 – 1.44	Fert	Soy Oil	0	FL&O	Hydrochloric Acid	0.80 – 1.0	Gasoline ⁴	0.39
Nitrogen Solution	1.17 – 1.44	Fert	Spindle Oil		FL&O	Phosphoric Acid	161	Jet A	
N-P-K Solutions	1.2 – 1.4	Fert	Sunflower Oil		FL&O	Sulfuric Acid	1.49	Jet A-1	1.8
Urea	1.89	Fert	Vegetable Oil	0	FL&O	Test C Product Category: Compressed Liquids, Fuels and Refrigerants (Comp liq)		Jet B	
6 Oil (#5, #6)	0.9	FL&O	Asphalt		Heated	Typical Products	Reference Viscosity ¹ (60 °F) centipoise (cP)	JP4	1.34
Asphalt		FL&O	Bunker C		Heated	Anhydrous Ammonia	0.188	JP5	2.56
Avgas		FL&O	Carbon Tetra- Chloride		Solv Cl	Butane	0.19	JP7 and JP8	2.4
Biodiesel above B20	0.86	FL&O	Methylene- Chloride		Solv Cl	Ethane		Kerosene	2.6
Bunker Oil	0.99	FL&O	Perchloro- Ethylene		Solv Cl	Freon 11	0.313	Light Oil	15.7
Cooking Oils	0.92	FL&O	Trichloro- Ethylene		Solv Cl	Freon 12	0.359	Lubricating Oils	22 – 1250
Corn Oil	0.91	FL&O	Acetates		Solv Gen	Freon 22	1.99	Olive Oil	127
Crude Oil	0.79 – 0.97	FL&O	Acetone	.02	Solv Gen	Propane	0.098	Peanut Oil	11 – 122
Diesel Fuel ³	0.84	FL&O	Ethylacetate	0.00001	Solv Gen	Test C Product Category: Clear Liquid Fertilizers (Fert)		SAE Grades	214 – 4037
Fuel Oil (#1, #2, #3, #4)	0.9	FL&O	Hexane	0	Solv Gen	Typical Products	Reference Viscosity ¹ (60 °F) centipoise (cP)	Soy Oil	97.6
Gasoline ⁴	0.72	FL&O	MEK	0.1	Solv Gen	9-18-0		Spindle Oil	
Jet A		FL&O	Toluene	0	Solv Gen	10-34-0	48	Sunflower Oil	97.1

NTEP - D / E5

Mass Meter Product Category and Test Requirements			Magnetic Flow Meter Product Category and Test Requirements			Positive Displacement Flow Meter Product Category and Test Requirements		Turbine Flow Meter Product Category and Test Requirements	
Jet A-1	0.76	FL&O	Xylene	0	Solv Gen	20% Aqua- Ammonia	1.1 – 1.3	Vegetable Oil	145
Jet B		FL&O	Deionized		Water	28%, 30% or 32%	31 – 110	Test E Product Category: Solvents General (Solv Gen)	
JP4	0.76	FL&O	Demineralized		Water	Ammonia Nitrate	11.22	Typical Products	Reference Kinematic Viscosity¹ (60 °F) centistokes (cSt)
JP5	0.76	FL&O				Clear Liquid Fertilizer	31 – 110	Acetates	0.47
JP7 and JP8	0.76	FL&O				Nitrogen Solution	31 – 110	Acetone	0.43
Typical Products	Specific Gravity² (60 °F)	Product Category	Test D To obtain coverage for a product category, test with one product in the product category. The Certificate of Conformance will cover all products in the category. <ul style="list-style-type: none"> • Test D does not apply to product categories of pure alcohols, pure glycol, pure water, solvents chlorinated, solvents general, fuels, lubricants, industrial and food grade liquid oils. • Test D does not apply to product categories of liquefied gases, compressed liquids or heated products. 			Test C Product Category: Clear Liquid Fertilizers (Fert) continued		Test E Product Category: Solvents General (Solv Gen) continued	
Kerosene	0.75	FL&O	Typical Products	Conductivity (micro- siemens/centimeter)	Product Category	Typical Products	Reference Viscosity¹ (60 °F) centipoise (cP)	Typical Products	Reference Kinematic Viscosity¹ (60 °F) centistokes (cSt)
Light Oil	0.86	FL&O	Water Mixes of Alcohols and Glycols		Alc Gly	N-P-K Solution		Ethylacetate	1.42
Lubricating Oils	0.80 – 0.90	FL&O	Banvel		CC-A	Urea	1	Hexane	0.52
Olive Oil	0.92	FL&O	Herbicides		CC-A	Test C Product Category: Fuels, Lubricants, Industrial and Food Grade Liquid Oils (FL&O)		MEK	0.56
Peanut Oil	0.9 – 1.0	FL&O	Paraquat		CC-A	Typical Products	Reference Viscosity¹ (60 °F) centipoise (cP)	Toluene	0.71
SAE Grades	0.9	FL&O	Prowl		CC-A	6 Oil (#5, #6)	66 – 13,000	Xylene	0.97
Soy Oil	0.93	FL&O	Round-up		CC-A	Asphalt	100 – 5000	Test A The following products must be individually tested and noted on the Certificate of Conformance.	
Spindle Oil		FL&O	Touchdown		CC-A	Avgas	1.5 – 6	Typical Products	Product Category
Sunflower Oil	0.93	FL&O	Treflan		CC-A	Biodiesel above B20	10.12	Banvel	CC-A
Vegetable Oil	0.92	FL&O	Adjuvants		CC-B	Bunker Oil	11,200	Herbicides	CC-A
Liquid Molasses	1.25	Liq Feed	Fumigants		CC-B	Cooking Oils	9.93	Paraquat	CC-A
Molasses Plus Phos Acid	1.1 – 1.3	Liq Feed	Fungicides		CC-B	Corn Oil	4	Prowl	CC-A

Mass Meter Product Category and Test Requirements			Magnetic Flow Meter Product Category and Test Requirements			Positive Displacement Flow Meter Product Category and Test Requirements		Turbine Flow Meter Product Category and Test Requirements	
and/or Urea (TreaChle)									
Carbon Tetra- Chloride	1.6	Solv Cl	Insecticides		CC-B	Crude Oil	3-1783	Round-up	CC-A
Methylene- Chloride	1.34	Solv Cl	Fungicides		CC-C	Diesel Fuel ³	10	Touchdown	CC-A
Perchloro- Ethylene	1.6	Solv Cl	Micronutrients		CC-D	Fuel Oil (#1, #2, #3, #4)	8 to 88	Treflan	CC-A
Trichloro- Ethylene	1.47	Solv Cl	Hydrochloric Acid	395000	Chem	Gasoline ⁴	0.28	Adjuvants	CC-B
Acetates	0.93	Solv Gen	Phosphoric Acid	56600	Chem	Jet A	1.5 – 6	Fumigants	CC-B
Typical Products	Specific Gravity ² (60 °F)	Product Category	Typical Products	Conductivity (micro- siemens/centimeter)	Product Category	Test C Product Category: Fuels, Lubricants, Industrial and Food Grade Liquid Oils (FL&O) continued		Typical Products	Product Category
Acetone	0.8	Solv Gen	Sulfuric Acid	209000	Chem	Typical Products	Reference Viscosity ¹ (60 °F) centipoise (cP)	Fungicides	CC-C
Ethylacetate	0.96	Solv Gen	9-18-0		Fert	Jet A-1	1.36	Insecticides	CC-B
Hexane	0.66	Solv Gen	10-34-0		Fert	Jet B	1.5 – 6	Fungicides	CC-C
MEK	0.81	Solv Gen	20% Aqua- Ammonia		Fert	JP4	1.02	Micronutrients	CC-D
Toluene	0.87	Solv Gen	28%, 30% or 32%		Fert	JP5	1.94	Hydrochloric Acid	Chem
Xylene	0.89	Solv Gen	Ammonia Nitrate		Fert	JP7 and JP8	1.82	Phosphoric Acid	Chem
Beverages	1.0	Water	Clear Liquid Fertilizer		Fert	Kerosene	1.94	Sulfuric Acid	Chem
Deionized	1.0	Water	Nitrogen Solution		Fert	Light Oil	13.47	NH ₃	Comp Liq
Demineralized	1.0	Water	N-P-K Solutions		Fert	Lubricating Oils	20 – 1000	20% Aqua- Ammonia	Fert
Juices	1.0	Water	Urea	5000	Fert	Olive Oil	116.8	28%, 30% or 32%	Fert
Milk	1.0	Water	Liquid Molasses	300	Liq Feed	Peanut Oil	11 – 110	9-18-0	Fert
Nonpotable	1.0	Water	Molasses Plus Phos Acid and/or Urea (TreaChle)		Liq Feed	SAE Grades	192 – 3626	10-34-0	Fert
Potable	1.0	Water	3-10-30		Sus Fert	Spindle Oil		Ammonia Nitrate	Fert
Tap Water	1.0	Water	4-4-27		Sus Fert	Soy Oil	90.6	Clear Liquid Fertilizer	Fert
Test D To obtain coverage for each of the following product categories, test with one product in each product category. The Certificate of Conformance will cover the products in the			Beverages		Water	Sunflower Oil	90.1	Nitrogen Solution	Fert

Mass Meter Product Category and Test Requirements			Magnetic Flow Meter Product Category and Test Requirements			Positive Displacement Flow Meter Product Category and Test Requirements		Turbine Flow Meter Product Category and Test Requirements		
product category in which a product was tested.										
Typical Products	Specific Gravity ² (60 °F)	Product Category	Juices		Water	Vegetable Oil	133	N-P-K Solutions	Fert	
Compressed Natural Gas (CNG)	0.6 – 0.8 (1=Air)	Comp gas	Nonpotable	72 ⁵	Water			Urea	Fert	
Anhydrous Ammonia	0.61	Comp liq	Potable	72 ⁵	Water			Bicep	Flow	
Butane	0.595	Comp liq	Tap Water	72 ⁵	Water			Broadstrike	Flow	
Typical Products	Specific Gravity ² (60 °F)	Product Category					Test C Product Category: Flowables (Flow)		Typical Products	Product Category
Ethane		Comp liq					Typical Products	Reference Viscosity ¹ (60 °F) centipoise (cP)	Doubleplay	Flow
Freon 11	1.49	Comp liq					Bicep	20 – 900	Dual	Flow
Freon 12	1.33	Comp liq					Broadstrike	20 – 900	Guardsman	Flow
Freon 22	1.37	Comp liq					Doubleplay	20 – 900	Harness	Flow
Propane	0.504	Comp liq					Dual	20 – 900	Marksman	Flow
Liquefied Natural Gas		Cryo LNG					Guardsman	20 – 900	Topnotch	Flow
Liquefied Oxygen	0.66	Cryo LNG					Harness	20 – 900	Asphalt	Heated
Nitrogen	0.31	Cryo LNG					Marksman	20 – 900	Bunker C	Heated
Asphalt		Heated					Topnotch	20 – 900	Liquid Molasses	Liq Feed
Bunker C	1.1	Heated	Test C Product Category: Heated (Heated)		Molasses plus Phos Acid and/or Urea (TreaChle)	Liq Feed				
Test A The following products must be individually tested and noted on the Certificate of Conformance.			Typical Products		Reference Viscosity ¹ (60 °F) centipoise (cP)	Carbon Tetra-Chloride	Solv Cl			
Compressed Hydrogen Gas (H or H2)	0.07 (1=Air)	Comp H2	Asphalt	100 – 5000	Methylene-Chloride	Solv Cl				
Liquid Carbon Dioxide	1.12 (-40 °F)	Liq CO2	Bunker C	11,200	Perchloro-Ethylene	Solv Cl				
			Test C Product Category:		Trichloro-Ethylene	Solv Cl				

NTEP - D / E8

⁵ This data point is suspected to be lower than that of normal tap water supplied for residential consumption.

Mass Meter Product Category and Test Requirements	Magnetic Flow Meter Product Category and Test Requirements	Positive Displacement Flow Meter Product Category and Test Requirements	Turbine Flow Meter Product Category and Test Requirements	
		Liquid Feed (Liq Feed)		
		Typical Products	Reference Viscosity¹ (60 °F) centipoise (cP)	Product Category
		Liquid Molasses	8640	3-10-30 Sus Fert
		Molasses Plus Phos Acid and/or Urea (TreaChle)	2882	4-4-27 Sus Fert
				Compressed Hydrogen Gas (H or H2) Comp H2
				Liquid Carbon Dioxide Liq CO2

Test C Product Category: Solvents Chlorinated (Solv Cl)	Test D To obtain coverage for a product category, test with one product in the product category. The Certificate of Conformance will cover all products in the category.		
Typical Products	Reference Viscosity¹ (60 °F) centipoise (cP)	Typical Products	Product Category
Carbon Tetra-Chloride	0.99	Liquefied Natural Gas	Cryo LNG
Test C Product Category: Solvents Chlorinated (Solv Cl) continued		Liquefied Oxygen	Cryo LNG
Typical Products	Reference Viscosity¹ (60 °F) centipoise (cP)	Nitrogen	Cry LNG
Methylene-Chloride	0.46	Beverages	Water
Perchloro-Ethylene	1	Deionized	Water
Trichloro-Ethylene	0.6	Demineralized	Water
Test C Product Category: Solvents General (Solv Gen)		Juices	Water
Typical Products	Reference Viscosity¹ (60 °F) centipoise (cP)	Milk	Water
Acetates	0.44	Nonpotable	Water
Acetone	0.34	Potable	Water
Ethylacetate	1.36	Tap Water	Water
Hexane	0.34		
MEK	0.45		
Toluene	0.62		

Mass Meter Product Category and Test Requirements	Magnetic Flow Meter Product Category and Test Requirements	Positive Displacement Flow Meter Product Category and Test Requirements	Turbine Flow Meter Product Category and Test Requirements												
		<table border="1"> <tr> <td>Xylene</td> <td style="text-align: center;">0.86</td> </tr> <tr> <td colspan="2">Test C</td> </tr> <tr> <td colspan="2" style="text-align: center;">Product Category: Suspension Fertilizers (Sus Fert)</td> </tr> <tr> <td style="text-align: center;">Typical Products</td> <td style="text-align: center;">Reference Viscosity¹ (60 °F) centipoise (cP)</td> </tr> <tr> <td style="text-align: center;">3-10-30</td> <td style="text-align: center;">100 – 1000</td> </tr> <tr> <td style="text-align: center;">4-4-27</td> <td style="text-align: center;">20 – 215</td> </tr> </table>	Xylene	0.86	Test C		Product Category: Suspension Fertilizers (Sus Fert)		Typical Products	Reference Viscosity¹ (60 °F) centipoise (cP)	3-10-30	100 – 1000	4-4-27	20 – 215	
Xylene	0.86														
Test C															
Product Category: Suspension Fertilizers (Sus Fert)															
Typical Products	Reference Viscosity¹ (60 °F) centipoise (cP)														
3-10-30	100 – 1000														
4-4-27	20 – 215														

	<p>Test D To obtain coverage for a product category, test with one product in the product category. The Certificate of Conformance will cover all products in the category.</p> <p style="text-align: center;">Product Category: Water (Water)</p> <table border="1"> <thead> <tr> <th style="text-align: center;">Typical Products</th> <th style="text-align: center;">Reference Viscosity¹ (60 °F) centipoise (cP)</th> </tr> </thead> <tbody> <tr><td>Beverages</td><td style="text-align: center;">1.0</td></tr> <tr><td>Deionized</td><td style="text-align: center;">1.0</td></tr> <tr><td>Demineralized</td><td style="text-align: center;">1.0</td></tr> <tr><td>Juices</td><td style="text-align: center;">1.0</td></tr> <tr><td>Milk</td><td style="text-align: center;">1.0</td></tr> <tr><td>Nonpotable</td><td style="text-align: center;">1.0</td></tr> <tr><td>Potable</td><td style="text-align: center;">1.0</td></tr> </tbody> </table> <p>Test D</p> <p style="text-align: center;">Product Category: Water (Water) continued</p> <table border="1"> <thead> <tr> <th style="text-align: center;">Typical Products</th> <th style="text-align: center;">Reference Viscosity¹ (60 °F) centipoise (cP)</th> </tr> </thead> <tbody> <tr> <td>Tap Water</td> <td style="text-align: center;">1.0</td> </tr> </tbody> </table> <p>Test A The following products must be individually tested and noted on the Certificate of Conformance.</p> <p style="text-align: center;">Product Category: Cryogenic Liquids and Liquefied Natural Gas (Cryo LNG)</p> <table border="1"> <thead> <tr> <th style="text-align: center;">Typical Products</th> <th style="text-align: center;">Reference Viscosity¹</th> </tr> </thead> <tbody> <tr> <td></td> <td></td> </tr> </tbody> </table>	Typical Products	Reference Viscosity ¹ (60 °F) centipoise (cP)	Beverages	1.0	Deionized	1.0	Demineralized	1.0	Juices	1.0	Milk	1.0	Nonpotable	1.0	Potable	1.0	Typical Products	Reference Viscosity ¹ (60 °F) centipoise (cP)	Tap Water	1.0	Typical Products	Reference Viscosity ¹			
Typical Products	Reference Viscosity ¹ (60 °F) centipoise (cP)																									
Beverages	1.0																									
Deionized	1.0																									
Demineralized	1.0																									
Juices	1.0																									
Milk	1.0																									
Nonpotable	1.0																									
Potable	1.0																									
Typical Products	Reference Viscosity ¹ (60 °F) centipoise (cP)																									
Tap Water	1.0																									
Typical Products	Reference Viscosity ¹																									

Mass Meter Product Category and Test Requirements	Magnetic Flow Meter Product Category and Test Requirements	Positive Displacement Flow Meter Product Category and Test Requirements	Turbine Flow Meter Product Category and Test Requirements																
		<table border="1"> <tr> <td></td> <td>(60 °F) centipoise (cP)</td> </tr> <tr> <td>Liquefied Natural Gas</td> <td></td> </tr> <tr> <td>Liquefied Oxygen</td> <td>0.038</td> </tr> <tr> <td>Nitrogen</td> <td>1.07</td> </tr> <tr> <td colspan="2">Test A The following products must be individually tested and noted on the Certificate of Conformance.</td> </tr> <tr> <td colspan="2">Product Category: Compressed Hydrogen Gas (Comp H2)</td> </tr> <tr> <td>Typical Products</td> <td>Reference Viscosity¹ (60 °F) centipoise (cP)</td> </tr> <tr> <td>Compressed Hydrogen Gas (H or H2)</td> <td>0.0097</td> </tr> </table>		(60 °F) centipoise (cP)	Liquefied Natural Gas		Liquefied Oxygen	0.038	Nitrogen	1.07	Test A The following products must be individually tested and noted on the Certificate of Conformance.		Product Category: Compressed Hydrogen Gas (Comp H2)		Typical Products	Reference Viscosity¹ (60 °F) centipoise (cP)	Compressed Hydrogen Gas (H or H2)	0.0097	
	(60 °F) centipoise (cP)																		
Liquefied Natural Gas																			
Liquefied Oxygen	0.038																		
Nitrogen	1.07																		
Test A The following products must be individually tested and noted on the Certificate of Conformance.																			
Product Category: Compressed Hydrogen Gas (Comp H2)																			
Typical Products	Reference Viscosity¹ (60 °F) centipoise (cP)																		
Compressed Hydrogen Gas (H or H2)	0.0097																		
		<table border="1"> <tr> <td colspan="2">Test A The following products must be individually tested and noted on the Certificate of Conformance.</td> </tr> <tr> <td colspan="2">Product Category: Liquid Carbon Dioxide (Liq CO2)</td> </tr> <tr> <td>Typical Products</td> <td>Reference Viscosity¹ (60 °F) centipoise (cP)</td> </tr> <tr> <td>Liquid Carbon Dioxide</td> <td>0.194</td> </tr> </table>	Test A The following products must be individually tested and noted on the Certificate of Conformance.		Product Category: Liquid Carbon Dioxide (Liq CO2)		Typical Products	Reference Viscosity¹ (60 °F) centipoise (cP)	Liquid Carbon Dioxide	0.194									
Test A The following products must be individually tested and noted on the Certificate of Conformance.																			
Product Category: Liquid Carbon Dioxide (Liq CO2)																			
Typical Products	Reference Viscosity¹ (60 °F) centipoise (cP)																		
Liquid Carbon Dioxide	0.194																		

Product Category Table – Category Abbreviations

Abbreviation	Product Category	Abbreviation	Product Category
Alc Gly	Alcohols, Glycols and Water Mixes Thereof	Fert	Fertilizers
CC-A	Crop Chemicals (Type A)	FL&O	Fuels, Lubricants, Industrial and Food Grade Liquid Oils
CC-B	Crop Chemicals (Type B)	Flow	Flowables
CC-C	Crop Chemicals (Type C)	Heated	Heated Products (Above 50 °C)
CC-D	Crop Chemicals (Type D)	Liq Feed	Liquid Feeds
Chem	Chemicals	Liq CO2	Liquid Carbon Dioxide
Comp gas	Compressed Gases	Solv Chl	Solvents Chlorinated
Comp H2	Compressed Hydrogen Gas	Solv Gen	Solvents General
Comp liq	Compressed Liquids (Fuels and Refrigerants, NH ₃)	Sus Fert	Suspension Fertilizers
Cryo LNG	Cryogenic Liquids and Liquefied Natural Gas	Water	Water

Note: The Typical Products listed in this table are not limiting or all-inclusive; there may be other products and product trade names, which fall into a product family. Water and a product such as stoddard solvent or mineral spirits may be used as test products in the fuels, lubricants, industrial, and food- grade liquid oils product family.

Appendix D/Sub-appendix F

National Type Evaluation Program Liquid Measuring Devices – Checklists and Test Procedures for Retail Motor Fuel Dispensers

(Agenda Item 10)

7. Indicating and Recording Elements

Code Reference: G-S.5.1. and G-UR.1.1. General

Indicating elements must be appropriately designed and adequate in amount. Specifically, a device must have sufficient display capacity to indicate the quantities and total prices, if it applies in the normal encountered specific application. Electronic devices shall either have sufficient display capacity to indicate the normal quantities and money values or automatically stop the delivery before exceeding the display capacity of either the quantity or total price. Analog indicating elements are required to have sufficient display capacity, or the device is not suitable for the application. This consideration may apply when evaluating a system that may be used in either a truck stop or an automobile service station.

- 7.1. Analog dispensers shall have adequate display capacity for the application. Yes No N/A
- 7.2. An electronic digital indicating element shall either:
- 7.2.1. Have adequate display capacity for the application. **OR** Yes No N/A
- 7.2.2. Automatically stop the delivery before exceeding the maximum quantity or maximum total price that can be indicated. Yes No N/A

Code Reference: G-S.5.2.2. Digital Indication and Representation; S.1.6.6. Agreement Between Indications

Basic operating requirements for devices are that:

- All digital values of like value in a system shall agree.
- A digital value shall agree with its analog representation to the nearest minimum graduation.
- Digital values shall round off to the nearest digital division that can be indicated or recorded.
- When a digital zero display is provided, the zero indication shall consist of at least one digit to the left and all digits to the right of the decimal point.

Due to limitations of some of the technologies used to transmit information from dispensers to service station consoles, some exceptions to these rules have been given to the indications on retail motor fuel dispensers and service station consoles. Exact agreement of digital quantity values is not required if only total price information is sent from the dispenser to the console. In these cases, the console calculates the quantity from the unit price set in the console. Consequently, the quantity indicated on the console may not agree exactly with the quantity indicated on the dispenser. However, if the console prints a customer receipt, then the quantity times unit price must equal the total price on both the dispenser and the printed receipt. In 2012, provisions were added to allow systems to apply post-delivery discounts. In cases where a system applies a post-delivery discount(s) to a fuel's unit price through an auxiliary element, the exception mentioned above does not apply and, therefore, the total volume quantity of the delivery shall be in agreement between all elements in the system. See LMD Code S.1.6.6.

Previously, the service station console was considered an auxiliary indication and did not have to satisfy the mathematical agreement requirement for money values (G-S.5.5.) A non-retroactive requirement effective January 1, 1988 requires all service station consoles installed after January 1, 1988 (not just new models) to satisfy the mathematical agreement of money values requirement (S.1.6.6.) The money value indication **prior to the application of any post-delivery discount** for dispensers and consoles must agree for all installations, both old and new.

For those systems consisting of a console and dispensers and equipped with pre-set volume, the dispenser must deliver at least the pre-set volume; it cannot deliver less. For example, if the console sends only the money equivalent of the pre-set volume to the dispenser, the dispenser shall deliver at least the pre-set volume. It may not stop at the first quantity amount that results in mathematical agreement with the money value equivalent of the pre-set volume if the quantity indication is less than the pre-set volume. Similarly, if a money value is pre-set, the dispenser is not properly designed if it always stops at the lowest quantity value that provides mathematical agreement with the pre-set money value.

Tests for agreement of digital values shall be performed in the post pay, prepay money, and pre-set volume modes. Agreement should be checked at several unit prices including the maximum unit price and with the dispenser operating at its maximum flow rate.

- 7.3. All total sale money value indications in a computing system are primary indications and must agree **prior to the application of any post-delivery discount**. Yes No N/A
- 7.4. Digital volume indications in a non-computing system must agree or "round off" to the nearest minimum unit that can be indicated or recorded. Yes No N/A
- 7.5. Manual quantity entries in invoice billing systems must be identified as such. Yes No N/A
- 7.6. When delivery from a computing device is based upon a pre-set volume, the quantity indicated on the dispenser and any auxiliary device must be equal to or greater than the pre-set volume and the dispenser and remote console must comply with G-S.5.5. Money Values, Mathematical Agreement. Yes No N/A
- 7.7. The quantity, unit price, and total price indications on the console shall be in mathematical agreement **prior to the application of any post-delivery discount**. Yes No N/A
- 7.8. The following applies when a quantity value indicated or recorded by an auxiliary element such as a console, ticket printer, or remote customer display, is a derived or computed value based on data received from a retail motor fuel dispenser. **When a system applies a post-delivery discount(s) to a fuel's unit price through an auxiliary element, the total volume of the delivery shall be in agreement between all elements in the system.**
- 7.8.1. **In systems that do not apply a post-delivery discount**, the quantity values indicated or recorded on a console, electronic cash register, or other auxiliary indicating or recording element may differ, however, **for all systems:**
- 7.8.1.1. All indicated or recorded total money values for an individual sale shall agree. **AND** Yes No N/A
- 7.8.1.2. The indicated or recorded quantity, unit price, and total sales price values shall be in mathematical agreement to the closest cent (e.g., within each element, the values indicated or recorded must meet the formula [quantity x unit price = total sales price] to the closest cent.) Yes No N/A

Examples: \$1.5549 rounds to \$1.55
\$1.5551 rounds to \$1.56
\$1.5550 rounds to either \$1.55 or \$1.56

- 7.9. The printed ticket and dispenser must comply with G.S.5.5. Money Values, Mathematical Agreement to the nearest cent (unit price x volume = total sale \pm 0.5 cent.) Yes No N/A
- 7.10. Digital values agree with their associated analog value to the nearest minimum graduation. Yes No N/A

Code Reference: G-S.5.5. Digital Money Values, Mathematical Agreement

Any recorded money value and any digital money value indication on a primary indicator must agree mathematically with its associated quantity (volume) representation or indication to the nearest one cent.

Formula: Unit Price x Indicated Volume = Total Sale \pm 0.5 cent

- 7.11. Check mathematical agreement of all primary indications (e.g., dispenser, console, printer) under the following conditions:
- 7.11.1. At various flow rates, including maximum and minimum. Yes No N/A
- 7.11.2. Snapping nozzle on and off several times during delivery. Check mathematical agreement each time flow is halted. Yes No N/A
- 7.11.3. At several unit prices including the low prices and the maximum pricing capability of the computer and when operating at the maximum flow rate. Yes No N/A
- 7.11.4. Turn the dispenser off during delivery with nozzle open. Yes No N/A

Code Reference: G-S.5.1. Indicating and Recording Elements/General

Discount Pricing

NIST Handbook 44 requires that, except for dispensers used for fleet sales, other price contract sales, truck refueling (e.g., truck stop dispensers used only to refuel trucks), when a product or grade is offered for sale at more than one unit price through a computing device, the selection of the unit price shall be made prior to delivery using controls on the device or through the deliberate action of the purchaser using: 1) controls on the device; 2) personal or vehicle mounted electronic equipment communicating with the system; or 3) verbal instructions.

Should the customer elect to use another method of payment following completion of delivery, the console may be used to recalculate the total price — provided the dispenser complies with all applicable *NIST Handbook 44* requirements. For example, the customer selects the credit card unit price on the dispenser and dispenses product at that unit price. However, the customer discovers that he forgot his credit card and decides to pay cash. In this case, the console might be used to calculate the total price at the cash unit price. In keeping with the intent of National Conference on Weights and Measures action in 1989 to require dispensers to calculate at all unit prices for which a product is offered for sale, it is anticipated that the console would be required to recalculate the new total price using the formula (quantity x unit price = total price.)

Except for fleet sales and other contract sales, a receipt providing the total volume, unit price, total computed price and product identity shall be available through a built-in or separate recording element for all transactions conducted with point-of-sale systems or devices activated by debit cards, credit cards, and/or cash. (Code Reference S.1.6.7) The recorded and displayed total fuel price on the receipt and dispenser, respectively, shall agree.

Selectable Unit Price Capability

Selectable unit price capability is a design feature that permits the customer to select the unit price for a particular transaction at the time of sale. A dispenser may then allow the unit price for a delivery to be

selected from two or more unit prices through the deliberate action of the purchaser using: 1) controls on the device; 2) personal or vehicle mounted electronic equipment communicating with the system; or 3) verbal instructions.

If the customer selects the unit price at the dispenser (e.g., cash or credit price), the selection may be made at any time prior to the start of product flow. The dispenser operating handle may be on when the selection is made. A system shall not permit a change to the unit price during delivery of product.

After a transaction is completed, the unit price displayed at the dispenser may be changed to a base unit price. However, the quantity and total price must be displayed on the face of the dispenser for at least 5 minutes or until the next transaction is initiated. Any display of quantity, unit price, and total price that does not mathematically agree occurs between transactions. This is permitted (in response to demands of device users) because the displayed values between "transactions" are not "significant" relative to the actual delivery process (transaction.)

The displayed unit price may revert to the base unit price immediately after the completion of a transaction, defined as the time the delivery has been terminated and payment has been settled. The payment may be automatic if the delivery is to a pre-paid amount. If the sale is prepaid, the delivery is considered terminated after the "handle" is in the off position or after the nozzle has been returned to the designed hanging position. This will allow the customer adequate time to observe that the prepaid amount has been reached. If the delivery stops short or overruns a prepaid amount, settling the payment means that money is either refunded or collected from the customer and the transaction is "cashed out" by the console operator.

In the case of invoice billing systems, such as card-lock or key-lock systems which compute the total sale price, it is considered not appropriate for the displayed unit price to revert to the base unit price immediately following a transaction. Because a receipt for the transaction may not be available, the customer must be allowed an adequate period of time following the delivery to record the transaction information. The transaction unit price must be displayed for at least 30 seconds, and the total price and the quantity must be displayed for at least 5 minutes following the completion of the delivery or the start of the next transaction. The delivery is considered complete after the "handle" is off or the nozzle has been returned to its designed hanging position.

- 7.12. A dispenser may be equipped with means for selecting more than one unit price, provided that the selected unit price cannot be changed after the initial flow begins. Yes No N/A
- 7.13. The selected unit price must be made clearly evident on the dispenser. Yes No N/A
- 7.14. Once selected the unit price cannot be changed by the operator at the console prior to or during the delivery. Yes No N/A
- 7.15. The selected unit price displayed at the dispenser prior to the delivery of product must be continuously displayed at the conclusion of the delivery by moving the operating mechanism to the "off" position, until the start of the next transaction by:
- 7.15.1. Movement of the operating mechanism to the "on" position. **OR** Yes No N/A
- 7.15.2. "Authorization/Approval" by the console operator, whichever occurs first. Yes No N/A
- 7.16. When a delivery is completed, the total price and quantity for that transaction shall be displayed on the face of the dispenser for at least 5 minutes or until the next transaction is initiated by using controls on the device or other user-activated (e.g., customer-activated) controls. Yes No N/A
- 7.17. In a system where a base unit price is automatically displayed on the dispenser after the completion of a transaction (e.g., product is dispensed and payment is settled), the dispenser may display the values for quantity, unit price, and total price that do not result in a mathematically correct equation. That is provided when the total price value displayed is divided by the quantity value displayed, the result is a unit price that is "posted" Yes No N/A

for a particular kind of transaction.

Credit Card- or Debit Card-Activated Retail Motor Fuel Dispenser

On card-activated retail motor fuel dispensers, the customer authorizes the dispenser by inserting the card or swiping the card through a slot. On credit card transactions, the customer is typically billed through the same methods as have been used for credit transactions handled through a station attendant. On debit card transactions, payment is made directly from the purchaser's account by electronic funds transfer.

- 7.18. A receipt must be available to the customer at the completion of the transaction. The issuance of the receipt may be initiated at the option of the customer. Yes No N/A
- 7.19. The customer receipt must contain the following information:
- 7.19.1. The identity (codes may be used) of the product purchased, the quantity purchased, the unit price, and the total price. Yes No N/A
- 7.19.2. Where a post-delivery discount(s) is applied, the sales receipt must provide:
- the total quantity, unit price, and total computed price that were displayed on the dispenser at the end of the delivery prior to any post-delivery discount(s);
 - an itemization of the post-delivery discounts to the unit price; and
 - the final total price of each fuel sale after all post-delivery discounts are applied.
See LMD Code S.1.6.8.
- 7.20. Cash Value Card - A cash value card that is initially encoded with the purchase price, authorizing a customer to purchase products up to the current cash value of the card. The value of the card is decreased in amounts equal to individual transactions. Yes No N/A
- Means shall be provided to the customer to determine the initial cash value of the card and the remaining cash value prior to and after each transaction.
- 7.21. Invoice Billing - Invoice billing is a process in which customers are billed for one or more transactions at the end of a billing period.
- 7.21.1. For computing systems, the date, quantity, unit price, and total price shall be recorded and shall agree with the indications on the dispenser. Yes No N/A
- 7.21.2. When non-computing analog dispensers are used and the billing is on the basis of individual quantities for each transaction (non-cumulative), the value of the smallest unit of displayed quantity for each transaction shall be not greater than 0.1 gallon providing the "pulser" and the recorded quantity used for billing are each equal to or less than 0.01 gallon. Yes No N/A
- 7.21.3. All displayed transaction information must be shown for at least 30 seconds after completing a delivery or starting the next transaction. The delivery is considered complete after the "handle" is off or after the nozzle has been returned to its designed hanging position. Yes No N/A

Code Reference: S.1.6.5.2. Money-Value Divisions, Digital

- 7.22. A computing type device with digital indications shall comply with the requirements of paragraph G-S.5.5. Money Values, Mathematical Agreement, and the total price computation shall be based on quantities not exceeding 0.05-liter intervals for devices indicating in metric units or 0.01-gallon intervals for devices indicating in inch-pound units. Yes No N/A

Note: At least four decimal places in cents must be carried to determine the proper round off of money values.

Code Reference: S.1.2. Primary Elements/Units

- 7.23. A liquid measuring device shall indicate, and record if the device is equipped to record, its deliveries in liters, gallons, quarts, pints, fluid ounces, or binary-submultiples or decimal subdivisions of the liter or gallon. Yes No N/A

Code Reference: S.1.2.3. Value of Smallest Unit

- 7.24. The value of the quantity division shall not exceed the equivalent of 0.5 L (0.1 gal) on retail devices with a flow rate of 750 L/min (200 gal/min) or less. Yes No N/A

Code Reference: S.1.6.1. Indication of Delivery

- 7.25. Retail devices shall automatically show their initial zero condition and amount delivered up to the nominal capacity of the device. For electronic devices manufactured on or after January 1, 2006, the measurement, indication of delivered quantity, and the indication of total sales price shall be inhibited until the fueling position reaches conditions necessary to ensure the delivery starts at zero. Yes No N/A
- 7.26. For electronic devices manufactured prior to January 1, 2006, the first 0.03 L (or 0.009 gal) of a delivery and its associated total sales price need not be indicated. Yes No N/A

Test Method Steps:

1. Set unit price on dispenser.
2. Pressurize system.
3. Turn the dispenser off.
4. Create void in dispenser hydraulics by opening the fuel nozzle to provide a zero internal pressure. Then close the fuel nozzle.
5. Activate the dispenser and let the system reset (for example, showing "8"s and then zero, running through a segment check, or using another method of resetting the system).
6. With the nozzle closed, watch the main sales display for advancement of total sales and total volume for at least 5 seconds and no more than 10 seconds.
7. No advancement constitutes a passing test.
8. Advancement constitutes a failed test.
9. Replace the fuel nozzle and turn off the dispenser.
10. Repeat this test 2 more times. *Note: The evaluator must be aware that a time delay for this feature may be incorporated.*
11. Device passes test. Yes No N/A

Code Reference: S.1.6.2.1. and S.1.6.2.2. Provisions for Power Loss

Even if power fails during a delivery, it is still necessary to correctly complete all transactions in progress at the time of the power failure. Quantity and total sales price information shall be recallable for at least 15 minutes after the power failure. The information may be recalled at the dispenser or at the console if the console indications are accessible to the customer. Operator information, such as fuel and money value totals, shall be retained in memory during a power failure. The operator information is not required to be recallable during the power failure, but shall be recallable after power is restored. Test to determine if the indications are accurate when the delivery is continued after a power failure.

Note: For remote controllers (e.g., cash register, console, etc.) which have the capability to retain information pertaining to a transaction (e.g., stacked completed sales.) If the information cannot be recalled at the dispenser following a power outage, means (e.g., uninterruptible power supply or other means) must be provided to enable the transaction information to be recalled and verified for at least 15 minutes following a power outage.

- 7.27. The quantity and total sales price shall be recallable for 15 minutes after the power failure. Yes No N/A
- 7.28. The quantity and total sales price values shall be correct if the power fails between deliveries. Yes No N/A
- 7.29. The quantity and total sales price values shall be correct if the delivery is continued after a power failure. Yes No N/A
- 7.30. The operator's information shall be retained in memory during a power failure. Yes No N/A
- 7.31. Remote controllers which stack completed sales must have a means to enable the transaction information to be recalled and verified for at least 15 minutes. Yes No N/A

Code Reference: S.1.6.3. Return to Zero

The primary indicating and recording elements of a retail device shall readily return to a definite zero indication. Key-lock and other self-operated devices must have a zero-return indicating element, but they are not required to have the recording element return to zero. These devices may be equipped with cumulative recording elements. The primary indicating and recording elements shall not go beyond their correct zero position.

- 7.32. Does the device have a primary recording element? Yes No N/A
- 7.33. The indicating and recording elements of a retail device shall readily return to a definite zero indication. Yes No N/A
- 7.34. Key-lock and self-operated devices shall have an indicating element that return to zero. Yes No N/A
- 7.35. Does the device have:
- 7.35.1. A cumulative indicating element? Yes No N/A
- 7.35.2. A cumulative recording element? Yes No N/A
- 7.36. Primary indicating and recording elements shall not go beyond their correct zero position. Yes No N/A

Code Reference: S.1.6.4.1. Display of Unit Price

A computing or money-operated device shall have a means on the face of the device for displaying the unit price at which it is set to compute or deliver. If a grade, brand, blend, or mixture is offered for sale at more than one unit price

from a device, then all of the unit prices at which that product is offered for sale shall be displayed or shall be capable of being displayed on the dispenser using controls available to the customer prior to the delivery of the product. The unit price shall be expressed as a decimal value in dollars.

7.37. Means shall be provided to display the unit price on the face of the device. Yes No N/A

7.38. If a grade, brand, blend, or mixture is offered for sale at more than one unit price from a device, then all of the unit prices at which that product is offered for sale:

7.38.1. Shall be displayed prior to the delivery of the product. **OR** Yes No N/A

7.38.2. Shall be capable of being displayed on the dispenser through the deliberate action of the purchaser using: 1) controls on the device; 2) personal or vehicle mounted electronic equipment communicating with the system; or 3) verbal instructions. Yes No N/A

Note: It is not necessary to simultaneously display all of the unit prices for all grades, brands, blends, or mixtures provided the dispenser complies with this section, S.1.6.4.1.

Note: For a system that offers post-delivery discounts on fuel sales, display of pre-delivery unit price information is exempt from 7.38, provided the system complies with S.1.6.8

The unit prices for each product and price level may be:

- a. Displayed simultaneously for all products.
- b. Displayed simultaneously for each product separately.; or
- c. Displayed individually in a unit-price display only if controls permit the customer to sequence the display through the unit prices for each and every product.

Note: Section 7.38.2 shall not apply to fleet sales, other contract sales, or truck refueling sales (e.g. sales from dispensers used to refuel trucks.)

7.39. The unit price shall be expressed in dollars and decimals of dollars using a dollar sign. A common fraction shall not appear in the unit price, (e.g., \$1.299 not \$1.29 9/10). Yes No N/A

Code Reference: S.1.6.4.2. Display of Product Identity

7.40. Means shall be provided to post the identity of the product grade, brand, blend, or mixture or dispensed product. Yes No N/A

Code Reference: S.1.6.5.5. Display of Quantity and Total Price

7.41. Except for aviation refueling applications, when a delivery is completed on a computing device, the total price and quantity for that transaction shall be displayed on the face of the dispenser for at least 5 minutes or until the next transaction is initiated by using controls on the device or other customer-activated controls. Yes No N/A

Note: The displayed unit price may revert to a base unit price immediately after the completion of a transaction, defined as the time the delivery has been terminated and payment has been settled. Any display of quantity, unit price, and total price that does not mathematically agree between transactions and is permitted (in response to demands of device users) because the displayed values between "transactions" are not "significant" relative to the actual delivery process (transaction.)

Code Reference: S.1.6.5.4. Selection of Unit Price

7.42. Except for dispensers used exclusively for truck refueling (e.g., truck stop dispensers used only to refuel trucks), when a product or grade is offered for sale at more than one unit price through a computing device, the selection of the unit price shall be made:

7.42.1. Prior to delivery using controls on the device. **OR** Yes No N/A

7.42.2. Through deliberate action of the purchaser using: 1) controls on the device; 2) personal or vehicle mounted electronic equipment communicating with the system; or 3) verbal instructions. Yes No N/A

Note: This requirement does not apply to devices for which the Certificate of Conformance is limited to installations where the devices are used exclusively for fleet sales, other price contract sales, and truck refueling (e.g., truck stop dispensers used only to refuel trucks.)

7.43. A system shall not permit a change to the unit price during delivery of product. Yes No N/A

Code Reference: S.1.6.8. Recorded Representations for Transactions Where a Post-Delivery Discount(s) is Provided

7.44. Where a post-delivery discount(s) is applied, the sales receipt must provide: Yes No N/A

- the total quantity, unit price, and total computed price that were displayed on the dispenser at the end of the delivery prior to any post delivery discount(s);

- an itemization of the post-delivery discounts to the unit price; and

- the final total price of each fuel sale after all post-delivery discounts are applied.

Code Reference: S.1.6.5.6. Display of Quantity and Total Price, Aviation Refueling Applications

7.45. a. The quantity shall be displayed throughout the transaction. Yes No N/A

b. The total price shall also be displayed under one of the following conditions:

i. The total price can appear on the face of the dispenser or through a controller adjacent to the device.

ii. If a device is designed to continuously calculate and display the total price, it shall be displayed for the quantity delivered throughout the transaction.

c. The total price and quantity shall be displayed for at least 5 minutes or until the next transaction is initiated by using controls on the device or other customer activated controls.

d. A printed receipt shall be available and shall include, at a minimum, the total price, quantity, and unit price.

8. Computing

A retail computing device shall be capable of computing total sale prices for all unit prices and for all deliveries within the range of measurement or computing capacity. The maximum value of the money-value division and the maximum variation of indicated total sale price from the mathematically computed total sale price are specified for analog devices. Because analog dispensers may have different money-value divisions

depending upon the unit price, the service station console must update in the same money-value division to maintain agreement of total sale price values. The maximum quantity-value divisions for digital devices are prescribed.

Code Reference: S.1.6.5. Money-Value Computations

- 8.1. A retail computing device shall compute total sale prices for all quantities and unit prices within the range of its quantity and computing capacities. Yes No N/A

Notes: For dispensers which are not capable of complying with the requirements of UR.3.2., UR.3.3., and S.1.6.5., the Certificate of Conformance must be limited to single-tier pricing applications. This requirement does not apply to devices for which the Certificate of Conformance is limited to installations where the devices are used for fleet sales, other price contract sales, and truck stop dispensers used only to refuel trucks.

- 8.2. Analog money value indications on each side of a device shall not differ from the mathematically computed money value (Quantity x Unit Price = Sales Price), for any delivered quantity, by an amount greater than the values shown in the following table: Yes No N/A

Unit Price		Money Value Division	Maximum Allowable Variation	
From	To and Including		Design Test	Field Test
0	0.25/liter or \$1.00/gallon	1¢	± 1¢	± 1¢
0.25/liter or \$1.00/gallon	0.75/liter or \$3.00/gallon	1¢ or 2¢	± 1¢	± 2¢
0.75/liter or \$3.00/gallon	2.50/liter or \$10.00/gallon	1¢, 2¢ or 5¢	± 1¢ ± 2.5¢	± 2¢ ± 5¢

See NIST Handbook 44 N.4.3. for Test Procedures

- 8.3. Total prices indicated on the two sides of an analog register shall agree within one-half of the money value division. Yes No N/A

Code Reference: S.1.6.5.1. Analog Money-Value Divisions

Analog money-value divisions shall be as follows:

- 8.4. Not more than 1 cent at all unit prices up to and including \$0.25 per liter or \$1.00 per gallon. Yes No N/A
- 8.5. Not more than 2 cents at all unit prices greater than \$0.25 per liter or \$1.00 per gallon up to and including \$0.75 per liter or \$3.00 per gallon. Yes No N/A
- 8.6. Not more than 5 cents at all unit prices greater than \$0.75 per liter or \$3.00 per gallon. Yes No N/A

Code Reference: S.1.6.5.2. Digital Money-Value Divisions

- 8.7. Digital quantity and total price indications shall agree to the nearest cent. Yes No N/A
- 8.8. Total price indications shall be based on quantity-value divisions that are less than or equal to 0.05 liters or 0.01 gallons. Yes No N/A

Code Reference: S.1.6.5.3. Money-Value Divisions, Auxiliary Indications

- 8.9. Money value divisions on devices such as remote consoles and printers shall be the same as on the dispenser. Yes No N/A

Code Reference: S.1.6.9. Travel of Indicator on Lubricant Devices

- 8.10. If the most sensitive element of the indicating system of a lubricant device uses an indicator and graduations, the relative movement of these parts shall be at least 2.5 cm (1 in) per 0.5 L (1 pt) of delivery. Yes No N/A

9. Measuring Elements

Code Reference: S.2.2. Provision for Sealing

Measuring elements shall be designed with adequate provisions to prevent changes from being made to the measuring element or the flow rate control (if the flow rate control affects the accuracy of deliveries) without evidence of the change being made. These provisions can be an approved means of security (e.g., data change audit trail) or physically applying a security seal which must be broken before adjustments can be made. When applicable, the adjusting mechanism shall be readily accessible for the purposes of affixing a security seal.

- 9.1. A measuring element shall have provisions for either:
- 9.1.1. Applying a physical security seal. **OR** Yes No N/A
 - 9.1.2. An approved means of security (e.g., data change audit trail) so that no changes may be made to its adjustable components. Yes No N/A
- 9.2. Any adjustable element controlling the delivery rate shall provide for sealing or other approved means of security (e.g., data audit trail) if the flow rate affects the accuracy of deliveries. Yes No N/A
- 9.3. When applicable, the adjusting mechanism shall be readily accessible for the purposes of affixing a security seal. Yes No N/A
- 9.4. Audit trails shall use the format set forth in the Common and General Code Criteria section of this checklist (Code Reference G-S.8) and in Appendix A, Audit Trail Checklist for Liquid Measuring Devices. Yes No N/A
- 9.5. Retail motor fuel dispensers with remote configuration capabilities shall be sealed according to Table S.2.2. in Appendix A, Minimum Requirements for Audit Trails for Liquid Measuring Devices and under the "Common and General Code Criteria" section of this checklist. Yes No N/A

Code Reference: S.2.2.1. Multiple Measuring Devices with a Single Provision for Sealing

- 9.6. A change to the adjustment of any measuring element shall be individually identified. Yes No N/A

Note: Examples of acceptable identification of a change to the adjustment of a measuring element include but are not limited to:

- a. A broken, missing, or replaced physical seal on an individual measuring element.
- b. A change in a calibration factor for each measuring element.
- c. Display of the date of or the number of days since the last calibration event for each measuring element.
- d. A counter indicating the number of calibration events per measuring element.

Note: S.2.2.1. will be removed in the 2010 edition of NIST Handbook 44 when General Code paragraph G S.8.1. Multiple Weighing or Measuring Elements with a Single Provision for Sealing becomes effective.

Code Reference: S.2.3. Directional Flow Valves

- 9.7. Values intended to prevent the reversal of flow shall be automatic in operation. Yes No N/A

Code Reference: S.2.4. Stop Mechanism

If a device is hand-operated via a crank, the device is likely to have "stops" or tabs designed to stop the cranking operation at the point representing the nominal quantity to be delivered in one cycle. The stops must be held securely in place and marked with the nominal quantity represented by one cycle of the cranking process.

- 9.8. Stops must be held securely in position. Yes No N/A
- 9.9. Each stop shall be marked with the nominal quantity to be delivered by cranking to each stop. Yes No N/A
- 9.10. Stops shall be adjustable so deliveries will be within tolerance. Yes No N/A

Code Reference: S.2.5. Zero-Set-Back Interlock

The zero-set-back interlock on a dispenser is critical to prevent fraudulent practices. A retail motor fuel device shall have an effective automatic interlock such that once the dispenser shuts off, it cannot be restarted without resetting the indicating element to zero. This requirement also applies to the recording element if one is present. The dispenser shall be designed so that the starting lever must be in the shut-off position and the interlock engaged before the discharge nozzle can be returned to its designed hanging position. If a single pump supplies more than one dispenser, then each dispenser shall have an automatic control valve that prevents product from being delivered by a dispenser until its indications have been set to zero.

- 9.11. After the device is turned off by moving the lever that stops the flow, a subsequent delivery shall be prevented until the indicators (and recording element if present) have returned to their correct zero positions. Yes No N/A
- 9.12. The starting lever shall be in shut off position and zero-set-back interlock engaged before the nozzle can be returned to its designed hanging position. That is any position where the tip of the nozzle is placed in its designed receptacle and the lock can be inserted. Yes No N/A
- 9.13. If more than one dispenser is connected to a single pump, an automatic control valve shall prevent fuel from being delivered until the indicating elements have been returned to their correct zero position and engaged. Yes No N/A
- 9.14. The use of the interlock shall be effective under all conditions when any control on the console, except a system emergency shut-off, is operating and after any momentary power failure. Yes No N/A

Code Reference: S.2.8. Lubricant Devices, Supply Exhaustion

A lubricant device that is not a meter type shall become inoperable or give a conspicuous and distinct warning when the level of the supply of lubricant becomes so low that it may affect the accuracy of the measurement.

10. Discharge Lines and Discharge Line Valves

Code Reference: S.3.1. Diversion of Measured Liquid

This paragraph does not apply to devices that comply with Paragraph S.3.2.

To prevent fraudulent practices, no means for which any measured liquid can be diverted from the measuring chamber or the discharge line of a device shall be available.

A device may have two or more delivery outlets if there are automatic means to insure that:

- a. Liquid can flow from only one outlet at a time. and
 - b. The direction of liquid flow is definitely and conspicuously indicated.
- 10.1. Except as identified above, it shall not be possible to divert measured liquid from the measuring chamber or the discharge line of the device. Yes No N/A
- 10.2. Two or more delivery outlets may be installed if there are automatic means to ensure that liquid can flow from only one outlet at a time, and the direction of flow for which the mechanism may be set at any time is definitely and conspicuously indicated. Yes No N/A
- 10.3. Except as identified above, an outlet that may be opened for purging or draining the measuring system or for recirculating, if recirculation is required in order to maintain the product in a deliverable state, shall be permitted only when the system is measuring food products, agri chemicals, biodiesel, or biodiesel blends. Effective automatic means shall be provided to prevent passage of liquid through any such outlet during normal operation of the measuring system and to inhibit meter indications (or advancement of indications) and recorded representations while the outlet is in operation. Yes No N/A

Code Reference: S.3.2. Exceptions

If suitable means are provided to prevent the diversion of liquid flow to other than the receiving vehicle, devices that are specifically installed for fueling trucks are exempt from the provisions of S.3.1. and may have two outlets operating simultaneously.

- 10.4. For devices that are specifically installed for fueling trucks, two outlets may be operated simultaneously only if suitable means are provided to ensure that diversion of flow to other than the receiving vehicle cannot readily be accomplished and is readily apparent. Such means include, but are not limited to, physical barriers to adjacent driveways, visible valves or lighting systems indicating which outlets are in operation, and explanatory signs. Yes No N/A

Code Reference: S.3.3. Pump-Discharge Unit

- 10.5. If a pump-discharge unit is equipped with a flexible discharge hose, it shall be a wet-hose type. Yes No N/A

Code Reference: S.3.5. Discharge Hose

- 10.6. A discharge hose shall be adequately reinforced. Yes No N/A

Code Reference: S.3.6. Discharge Valve

- 10.7. A discharge valve may be installed in the discharge line only if the device is of the wet-hose type. Yes No N/A

Code Reference: S.3.7. Antidrain Valve

- 10.8. A wet-hose, pressure-type device shall have an effective anti-drain valve incorporated in the discharge valve or adjacent thereto. Yes No N/A

11. Marking

Code Reference: S.4.1.1. Marking Requirements; Limitation on Use

- 11.1. If a device is intended to accurately measure only products having particular properties or under specific installation or operating conditions or when used in conjunction with specific accessory equipment, these limitations shall be clearly and permanently stated on the device. A meter may be used to measure both gasoline and diesel fuel at different times provided the meter is tested and adjusted with the product to be measured before it is used commercially. Yes No N/A

Code Reference: S.4.4. Marking Requirements For Retail Devices Only

- 11.2. On a retail device with a designed maximum discharge rate of 115 L/min (30 gpm) or greater, the maximum and minimum discharge rates shall be marked in accordance with *NIST Handbook 44* S.4.4.2. The minimum rate shall not exceed 20% of the maximum discharge rate. Yes No N/A

Example: With a marked maximum discharge rate of 230 L/min (60 gpm), the marked minimum discharge rate shall be 45 L/min (12 gpm) or less (e.g., 40 L/min (10 gpm) is acceptable.) A marked minimum discharge rate greater than 45 L/min (12 gpm) (e.g., 60 L/min (15 gpm)) is not acceptable.

Code Reference: S.4.4.2. Location of Marking Information

- 11.3. The required marking information in the General Code, paragraph G-S.1. shall be located as follows:
- 11.3.1. Shall be within 24 to 60 inches from the base of the dispenser. Yes No N/A
- 11.3.2. May be internal and/or external provided the information is permanent and easily read. Yes No N/A
- 11.3.3. **Shall** be on a portion of the device that cannot be readily removed or interchanged (e.g., not on a service access panel.) Yes No N/A

Note: The use of a dispenser key or tool to access internal marking information is permitted.

12. Totalizers

Code Reference: S.5.1. Totalizers for Retail Motor Fuel Dispensers

- 12.1. Retail motor fuel dispensers shall be equipped with a non-resettable totalizer for the quantity delivered through the metering device. Yes No N/A

13. User Requirements

Code Reference: UR.1.1. Length of Discharge Hose

- 13.1. The length of a discharge hose shall not exceed 5.5 m (18 ft), but marinas and airports may have hoses up to 15 m (50 ft) long. Yes No N/A
- 13.2. If the length of a discharge hose in a marina or airport exceeds 8 m (26 ft), it shall be adequately protected from environmental factors. Yes No N/A

Code Reference: UR.3. Use of Device

Note: For dispensers which are not capable of complying with the requirements of UR.3.2., UR.3.3., and S.1.6.5., the Certificate of Conformance must be limited to single-tier pricing applications.

14. Installation Requirements

Code Reference: UR.2.1. Installation

- 14.1. A device shall be installed according to the manufacturer's instructions, and the installation shall be sufficiently secure and rigid to maintain this condition. Yes No N/A

Code Reference: UR.2.2. Discharge Rate

- 14.2. Actual maximum discharge rate shall not exceed the rated maximum discharge rate. Yes No N/A

15. Card-Activated Retail Motor Fuel Dispensers

Code Reference: G-S.2. Facilitation of Fraud

Accidental or intentional fraud causes great concern when customers use card-activated systems in service stations, bank-card-activated systems directly access bank accounts. The following criteria and test procedures apply to card-activated retail motor fuel dispensers.

A card-activated system shall authorize the dispensing of product for not more than three minutes for the time between authorization and "handle on" at the dispenser. It shall properly record transactions on the appropriate card account.

When a card-activated system is subjected to power loss of greater than 10 seconds, the dispenser shall de-authorize. Because systems may be installed with separate power lines to the console, card reader, and dispenser, tests should be run with power failures to different parts of the system to evaluate the potential for accidental or intentional errors. The appropriate device response depends when the power loss occurs during the delivery sequence.

- 15.1. The dispenser must de-authorize in not more than three minutes if the pump "handle" is not turned on. Yes No N/A
- 15.2. If the time limit to deactivate a dispenser is programmable, it shall not accept an entry greater than three minutes. Yes No N/A
- 15.3. When a power loss greater than 10 seconds occurs after the pump "handle" is on, the dispenser must de-authorize. Yes No N/A
- 15.4. When there is a loss of power, but the pump "handle" is not on, the dispenser must de-authorize in not more than three minutes. Yes No N/A

16. Test Methods for Card-Activated Retail Motor Fuel Dispensers

- 16.1. Authorize the dispenser and, with the pump "handle" on, interrupt power to any part (or all) of the system. The pump should deauthorize immediately. Specifically:
- 16.1.1. Authorize with a card and turn the "handle" on. Power down briefly, then restore power. Try to dispense product: the dispenser must not dispense because the power failure should have de-authorized the dispenser. Yes No N/A
- 16.2. Authorize the dispenser using a card (leaving handle off); wait more than three minutes, and try to start the dispenser. It should not start because the

authorization should have timed out. Specifically:

16.2.1. Authorize with a card, but do not turn the "handle" on. Power down for more than three minutes, and then restore power. Try to dispense product; the dispenser should have "timed-out" and not dispense. Yes No N/A

16.2.2. Authorize and dispense with card #1. Allow the system to time out and de-authorize (if it does). Do not turn off the "handle." Authorize and dispense with card #2. The transactions shall be properly recorded for each card. Yes No N/A

Note: A mechanical register may accumulate the two deliveries, but the printed record must not have accumulated values.

16.2.3. Authorize with card #1. Turn the "handle" on, then off. Authorize with card #2. Dispense product and complete the delivery. Check the printed receipt to verify that the delivery has been properly charged to card #2. Yes No N/A

16.2.4. Turn the dispenser "handle" on, and use a card to authorize the dispenser. Turn the "handle" off. After a period of 15 seconds, turn the "handle" on. Try to deliver product; the dispenser must not dispense. Yes No N/A

16.2.5. Authorize with card #1 (do not turn the "handle" on) and interrupt power for at least 10 seconds. This should de-authorize the dispenser. Resupply power; turn the "handle" on; try to dispense. The dispenser shall not deliver product. Yes No N/A

Note: The term "handle" generically refers to the handle, flapper, start button, on/off switch, or other mechanism used to activate or deactivate the dispenser.

16.2.6. Authorize with card #1; turn the "handle" on, and then interrupt power. This should de-authorize the dispenser. Resupply power and authorize the dispenser with card #2. Then, complete a delivery. Verify that the transaction is charged to card #2. Yes No N/A

Note: This test is not required if the device under test complies with paragraph 16.1.

16.2.7. Authorize a dispenser with card #1, but do not turn the dispenser "handle" on. Try to authorize the same dispenser with card #2; it should not be accepted until after the 3 minute time-out. Yes No N/A

16.3. Attempt to override or confuse the card system by varying the length of time the card is in the slot, (e.g., vary the "swipe" times) and pushing all other keys on the keypad during each step of the authorization process. Yes No N/A

National Type Evaluation Program Liquid Measuring Devices – Checklists and Test Procedures for Cash-Activated Retail Motor Fuel Dispensers

The following criteria and test procedures apply to cash-activated retail motor fuel dispensers. Tests using various denominations of bills accepted by the cash acceptor should be performed.

Certificates of Conformance will cover the use of the cash acceptor option at both attended and unattended stations. Cash Acceptors which are used at unattended locations must meet the marking requirements of paragraph G-UR.3.4. Responsibility, Money-Operated Devices shall be clearly and conspicuously displayed on the device or immediately adjacent to the device information detailing the return of monies paid when the product cannot be obtained.

17. Code Reference: S.1.6.2. Provisions for Power Loss

Even if power is interrupted during a delivery, it is still necessary to correctly complete all transactions in progress at the time of the power interruption. In the event of a power loss, the information needed to complete any transaction in progress at the time of the power loss (such as the quantity and unit price, sales price, or amount of money already inserted into the cash acceptor) shall be determinable for at least 15 minutes at the dispenser or at the console or journal printer if the console or journal printer is accessible to the customer.

All portions of the transaction must be accounted for in order to complete the transaction. This information would include the following: (1) the total amount of money that was inserted into the device prior to the power interruption, (2) the amount of product already dispensed (which should be available from the dispenser and which must comply with the requirements of S.1.6.2., (3) and any bill that has been inserted but has not yet been recognized by the cash acceptor.

Note: For bills that have not yet been drawn into the cash acceptor to the point that the bill is no longer visible, it is assumed that the information on the bill denomination can be obtained from visual examination.

Various methods may be used to recall specific portions of the transaction depending on how the basic system operates. For example, systems that can print a record of the amount fed into the machine as each bill is fed into the device maintain an ongoing record of bills recognized by the system. Other systems may not print a receipt until the end of the transaction, so the information is recalled on a journal printer accessible to the customer or can be recalled on the cash acceptor display.

Check to see what happens when the power is interrupted at different points of the transaction. Note what occurs at the points where power is interrupted, what information is provided to the customer on the receipt, audibly and visually in the form of instructions or error messages. Because systems may be installed with separate power lines to the console, card reader, and dispenser may be installed, tests should be run with power interruptions to different parts of the system to evaluate the potential for accidental or intentional errors. The appropriate device response depends upon when the power loss occurs during the delivery sequence.

- 17.1. Systems with Battery Back-up or Uninterruptible Power Supply or Equivalent - Some systems are equipped with a battery back-up or an uninterruptible power supply (or equivalent) which allows a transaction to continue in the event of a power loss. For such systems, the transaction in progress at the time of a power interrupted must continue as if no power interruption had occurred (or comply with the requirements for systems not equipped with a battery back-up.) That is, all bills (including bills being fed into the device at the time of the power loss) must be correctly accounted for, and the quantity and total sale amounts must be mathematically correct. Yes No N/A

Check these systems by interrupting power at several points in the transaction to ensure that all information (total price, quantity, mathematical agreement, and total dollar amount inserted by the customer) is accounted for correctly.

All Other Systems: To check the operation of systems not equipped with a battery backup, uninterruptible power supply, or equivalent, interrupt power as described below. As noted earlier, if separate power lines supply different components in the system, interrupt power to different parts of the system.

- 17.2. When one or more bills has been accepted and registered by the device, but product has not yet been dispensed, at least one of the following criteria must be met to ensure that this information can be recalled in the event of a power interruption:
- 17.2.1. The denomination of the bill must be printed by the printer on the device as the device recognizes the bill. (The printed receipt must be available to the customer.) Yes No N/A
 - 17.2.2. The denomination of each bill must be printed by a journal or other printer accessible to the customer as each bill is recognized by the device. Yes No N/A
 - 17.2.3. The running total display must be capable of being recalled for at least 15 minutes. Yes No N/A
 - 17.2.4. Means provided to enable the customer to retrieve the money inserted into the device (e.g., a button which can be used during a power interruption to eject the money inserted by the customer.) Yes No N/A
 - 17.2.5. Other means used to provide a visual or printed record of the total amount of money accepted by the device. Yes No N/A
- 17.3. There is a brief period of time during which a bill has been accepted by the cash acceptor but has not yet been recognized by the device. The following criteria must be met to ensure that this information can be recalled in the event of a power failure.
- 17.3.1. Means provided to enable the attendant or customer to retrieve the bill (for example, a button which can be used during a power interruption to eject the bill or if the cash acceptor box can be removed by the attendant and the bill retrieved.) Yes No N/A

Note: There may be a space of time in which a bill can be caught partially in and out of the cash acceptor during a power interruption. In such a case, if the denomination of the bill is visible to the customer and attendant, this is sufficient to provide information about the bill being fed into the device at the time of the power interruption. The cash acceptor must comply with the other applicable items noted above.

It is expected that the retail motor fuel dispenser will comply with S.1.6.2. and the information on the product already dispensed can be recalled through this portion of the system.

- 17.4. Power should be interrupted at different points in the transaction to determine that all transaction information can be recalled in the event of a power interruption including combinations of the following:
- 17.4.1. After one bill has been inserted. Yes No N/A
 - 17.4.2. After several bills have been inserted. Yes No N/A
 - 17.4.3. While a bill is being inserted. Yes No N/A
 - 17.4.4. After a bill has been inserted but not yet recognized. Yes No N/A

- 17.4.5. After a bill(s) has been inserted and recognized, but the on/off handle is still in the "off" position. Yes No N/A
- 17.4.6. After a bill(s) has been inserted and recognized, the on/off handle is in the "on" position, but no product has been dispensed. Yes No N/A
- 17.4.7. After a bill(s) has been inserted and recognized, the on/off handle is in the "on" position, and product is being dispensed. Yes No N/A

Code Reference: G-S.5.1. Indicating and Recording Elements, General; S.1.6.8. Recorded Representations for Transactions Where a Post-Delivery Discount(s) is Provided

- 17.5. Total Money Display - A running display showing the amount of money fed into the machine must be provided. It is not necessary for this information to be displayed once the customer initiates delivery. Yes No N/A
- 17.6. Printed Receipt - A printed receipt must be available to the customer from the device at the completion of the transaction. The issuance of the receipt may be initiated at the option of the customer. Yes No N/A

17.6.1. The customer receipt must contain the following information:

- 17.6.1.1. The identity (codes may be used) of the product purchased, the quantity purchased, the unit price, and the total price. Yes No N/A

Because the customer must be provided with the option of receiving a receipt, the system must not accept cash if sufficient paper is not available to complete the transaction.

- 17.6.1.2. Where a post-delivery discount(s) is applied, the sales receipt must provide: Yes No N/A

- the total quantity, unit price, and total computed price that were displayed on the dispenser at the end of the delivery prior to any post-delivery discount(s);

- an itemization of the post-delivery discounts to the unit price; and

- the final total price of each fuel sale after all post-delivery discounts are applied.
See LMD Code S.1.6.8.

17.7. The cash acceptor must not initiate a cash transaction if either of the following conditions is true:

- 17.7.1. No paper is in the receipt printer of the cash acceptor. Yes No N/A
- 17.7.2. Insufficient paper is available to complete a transaction. Yes No N/A

Code Reference: G-S.6. Marking Operational Controls, Indications, and Features

- 17.8. Instructions must be marked on the device to inform the customer how to operate the cash acceptor. Yes No N/A

Code Reference: G-S.2. Facilitation of Fraud

- 17.9. Means must be provided for the customer to cancel the transaction at any point.

- 17.9.1. The customer has inserted cash, but has not yet dispensed product. If the customer cancels the transaction by pressing the cancel key (or equivalent key(s)) or by lowering the on/off handle, the device must either:
- 17.9.1.1. Be equipped with means for the customer to retrieve the cash inserted from the device. **AND**
Automatically issue a printed receipt indicating the amount tendered and the amount returned. **OR** Yes No N/A
- 17.9.1.2. Display instructions (such as "sale terminated, see attendant," "sale terminated, get receipt" or similar wording) for the customer to see the attendant. **AND**
Automatically issue a printed receipt showing the amount of cash inserted by the customer, a statement indicating that the sale was terminated, and instructions for the customer to see the attendant. Yes No N/A
- 17.9.2. The customer has inserted cash and has started dispensing product. If the customer cancels or discontinues the transaction by pressing the cancel key (or equivalent key(s)) or lowering the on/off handle before reaching the total money inserted into the device, the device must:
- 17.9.2.1. Display instructions for the customer to obtain the receipt and to see the attendant. Yes No N/A
- 17.9.2.2. Automatically issue a printed receipt showing the amount of cash inserted, the amount dispensed, the balance due to the customer, a statement indicating that the sale was terminated, and instructions for the customer to see the attendant. Yes No N/A

Note: It is acceptable for different messages to be used. This depends upon whether the transaction is terminated by use of the cancel key, (e.g., "sale terminated, get receipt" or "sale terminated, see attendant") or by lowering the on/off handle, (e.g., "change due, see attendant.")

Appendix D/Sub-appendix G

National Type Evaluation Program

**Post Delivery Discount Revisions – Publication 14
Electronic Cash Register Interfaced with Retail Motor Fuel Dispensers**

(Agenda Item 10)

THIS PAGE INTENTIONALLY LEFT BLANK



Appendix G- Post-Delivery Discount revisions-Publication_14_ECR_Interfaced_with_RMFD_DRAFT revised 10-6-12

National Conference on Weights and Measures
National Type Evaluation Program

**Electronic Cash Register
Interfaced with
Retail Motor Fuel Dispensers**

Technical Policy • Checklists • Test Procedures



NCWM

Publication 14

© 2012

THIS PAGE INTENTIONALLY LEFT BLANK

Acknowledgements

The contents of this publication are the result of extensive meetings of the National Type Evaluation Program (NTEP) Technical Sectors and working groups assembled by National Conference on Weights and Measures (NCWM). The support, technical expertise, and judgment brought by members of industry and weights and measures officials have been critical to the development of the technical policy, checklists and test procedures. The contributions of all sector and work group members are greatly appreciated. The work to maintain these checklists continues.

We acknowledge and thank the technical advisor to the sectors from the National Institute of Standards and Technology, Office of Weights and Measures and the private sector, including Mr. Marc Buttler of the Measuring Sector and Mr. Doug Bliss of the Software Sector for their significant contributions. They have spent many hours before, during and after the sector meetings to prepare for, actively participate in and summarize the proceedings of these meetings.

We recognize the Measuring Sector Chair, Mr. Michael Keilty and Software Sector Co-Chairs Mr. Norman Ingram and Mr. James Pettinato in helping to organize and conduct the sector meetings in a fair and consensus-building manner. The recommendations forwarded from the sector to the NTEP Committee are the result of their guidance and leadership.

We also acknowledge the NTEP Committee for its careful assessment of the recommendations presented by the sector, commenting and revising when necessary, and approving the recommendations for inclusion in these checklists.

These contributions from so many people have resulted in a reference book that will help device manufacturers to design devices in compliance with *NIST Handbook 44* and promote uniform procedures and assessment by type evaluation by the laboratories. This is a goal of NTEP.

THIS PAGE INTENTIONALLY LEFT BLANK

Amendments

Electronic Cash Register Interfaced with Retail Motor Fuel Dispensers

<i>Section Number</i>	<i>Amendment</i>	<i>Page</i>	<i>Source</i>
Document	Please note that the NTEP Measuring Devices publication has been thoroughly reviewed by NCWM staff. Changes have been made, but none are to change intent of the policies, checklists or test procedures, thus considered editorial. Issues or concerns should be brought to the attention of NCWM staff.	Document	Editorial

THIS PAGE INTENTIONALLY LEFT BLANK

Table of Contents

Section	Page ECRD
Checklists and Test Procedures	
1. Identification.....	11
2. Indicating and Recording Elements	13
3. Recorded Representations.....	14
4. Provisions for Sealing.....	15

THIS PAGE INTENTIONALLY LEFT BLANK

National Type Evaluation Program Electronic Cash Register Interfaced with Retail Motor Fuel Dispenser Checklists and Test Procedures

Introduction

This checklist is intended for use when conducting general evaluations of new electronic cash registers (ECR) that are to interface with retail motor fuel dispensers. It is assumed that the dispenser was previously evaluated, if not, the Liquid Measuring Device checklist must be applied to the dispenser sale system. The ECR must interface with a dispenser to perform this evaluation. Specific criteria that apply to service station control consoles are in the checklist for retail motor fuel dispensers and must be applied if the cash register also serves as the service station controller. As a minimum, two dispensers from different manufacturers, each of which includes all of the features to be listed on the ECR Certificate of Conformance (CC), must be evaluated with the ECR in order to have the statement "equivalent and compatible equipment" appear on the CC.

This checklist is designed in a logical sequence for the user to determine and record the conformance of the device with the elements of *NIST Handbook 44*. The user should make copies of the checklist to serve as worksheets and preserve the original for reference. In most cases, the results of evaluation for each element can be recorded by checking the appropriate response. In some cases, the user is required to record values, results, or comments. In those cases, space is provided.

Identification

Code Reference: G-S.1. General

Each cash register must comply with the appropriate *NIST Handbook 44* identification requirements.

All equipment, except weights and separate parts necessary to the measurement process but not having any metrological effect, shall be clearly and permanently marked for the purposes of identification with the following information (prefix lettering may be initial capitals, all capitals, or all lower case.)

Location of the information:

- | | |
|--|---|
| 1.1. The name, initials, or trademark of the manufacturer or distributor. | <input type="checkbox"/> Yes <input type="checkbox"/> No <input type="checkbox"/> N/A |
| 1.2. A model identifier that positively identifies the pattern or design of the device. The model identifier shall be prefaced by the word "Model," "Type," or "Pattern." These terms may be followed by the word "Number" or an abbreviation of that word. The abbreviation for the word "Number" shall, as a minimum, begin with the letter "N" (e.g., No or No.) The abbreviation for the word "Model" shall be "Mod" or "Mod." Prefix lettering may be initial capitals, all capitals, or all lower case. | <input type="checkbox"/> Yes <input type="checkbox"/> No <input type="checkbox"/> N/A |
| 1.3. Except for equipment with no moving or electronic component parts and not built for purpose, software-based devices, a non-repetitive serial number. The serial number shall be prefaced by the words "Serial Number" or an abbreviation, or a symbol, that clearly identifies the number as the required serial number. Abbreviations for the word "Serial" shall, as a minimum, begin with the letter "S," and abbreviations for the word "Number" shall, as a minimum, begin with the letter "N" (e.g., S/N, SN, Ser. No, and S No.) | <input type="checkbox"/> Yes <input type="checkbox"/> No <input type="checkbox"/> N/A |
| 1.4. For not built-for-purpose, software based devices the current software version designation. The version or revision identifier shall be prefaced by the word "Version" or "Revision" as appropriate and either word may be followed by the word "Number." The abbreviations for the word "Version" shall, as a minimum, | <input type="checkbox"/> Yes <input type="checkbox"/> No <input type="checkbox"/> N/A |

begin with the letter "V." Abbreviations for the word "Revision" shall, as a minimum, begin with the letter "R." The abbreviations for the word "Number" shall, as a minimum, begin with the letter "N" (e.g., No or No.)

Code Reference: G-S.1. (e)

- 1.5. An NTEP Certificate of Conformance (CC) Number or a corresponding CC addendum number for devices that have (or will have) a CC. The number shall be prefaced by the terms "NTEP CC," "CC," or "Approval." These terms may be followed by the word "Number" or an abbreviation for the word "Number." The abbreviation for the word "Number" shall as a minimum begin with the letter "N" (e.g., No or No.) Yes No N/A

The device must have an area, either on the identification plate or on the device itself, suitable for the application of the Certificate of Conformance Number. If the area for the CC number is not part of an identification plate, then note its intended location below and how it will be applied.

1.5.1. Location of CC Number if not located with the identification information:

- 1.6. The required information shall be so located that it is readily observable without the necessity of the disassembly of a part requiring the use of any means separate from the device. Yes No N/A
- 1.7. The device must be marked with a unique serial number to identify the electronic element that controls the system. A remote display is not required to have a serial number because it usually does not have any electronics to analyze the signal received from the measuring element. Similarly, other elements of a system, (e.g., a printer, keyboard, cash drawer etc.) which cannot be operated as stand-alone units or are not intended to interface in a system of other models are not required to have a serial number. Yes No N/A
- 1.8. The marking must be visible after installation. Yes No N/A
- 1.9. Equipment is to be marked on a surface that is an integral part of the chassis, which is visible after installation. If the required information is located on the back of the device, the same information must also appear on the side, front, or top. It may be installed on the housing only if the housing can be fitted with a security seal. The bottom of a device is not an acceptable surface. Yes No N/A
- 1.10. The marking must be permanent. It may be a metal or plastic plate attached with pop rivets, adhesive, or other means. Removable bolts or screws are not permitted. A foil plate may be used provided it is destroyed in any attempt to remove it. Additionally, the printing on a foil plate must be easily read and not easily obliterated by rubbing with a relatively soft object (e.g., the wood of a pencil.) Yes No N/A

Note: A location under a cover or inside a panel door is acceptable. Visibility may be achieved by placing a duplicate serial number badge on the front, side, or top of the ECR. This badge may contain only the serial number if the other information is visible elsewhere on the ECR.

Code Reference: G-S.1.1. Location of Marking Information for Not Built-for-Purpose, Software-Based Devices

1.1. For not built-for-purpose, software-based devices, the following shall apply:

- 1.1.1. The required information in G-S.1 Identification. (a), (b), (d), and (e) shall be permanently marked or continuously displayed on the device. **OR** Yes No N/A
- 1.1.2. The Certificate of Conformance (CC) Number shall be:
- 1.1.2.1. Permanently marked on the device. **OR** Yes No N/A
- 1.1.2.2. Continuously displayed. **OR** Yes No N/A
- 1.1.2.3. Accessible through an easily recognized menu and, if necessary, a submenu. Examples of menu and submenu identification include, but are not limited to "Help," "System Identification," "G S.1. Identification," or "Weights and Measures Identification." Yes No N/A

Note: For (1.1.2.), clear instructions for accessing the information required in G-S.1. (a), (b), and (d) shall be listed on the CC, including information necessary to identify that the software in the device is the same type that was evaluated.

Indicating and Recording Elements

Code Reference: G-S.5.1. Price Look-up Codes (PLUs)

- 2.1. PLUs must operate only with appropriate information, (e.g., if a PLU activates a dispenser transaction, a volume input is required before a price is computed and recorded.) Yes No N/A
- 2.2. Other PLUs must not interact with dispenser information. Yes No N/A
- 2.3. Manual volume entries are permitted. They must be clearly identified on the receipt as a manual entry by the terms "Manual Fuel Sale." Yes No N/A

Note: All uppercase or a combination of upper and lower case letters are permitted provided the evaluating laboratory finds the resulting text to be clear and legible.

- 2.4. Incorrect entries shall be signaled by an audio and/or visual signal. Yes No N/A
- 2.5. A dispenser verification display (e.g., segment test) shall not be recorded by the ECR. Yes No N/A

Code Reference: S.1.6.2. Provision for Power Loss

- 2.6. Power Interruptions. First test with a power failure to the ECR alone. Then a power failure to the dispenser alone. Finally, a power failure to both components simultaneously. When power interruption occurs, the register must do one of the following:
- 2.6.1. Continue to function and perform correctly either automatically or manually. Yes No N/A
- 2.6.2. The transaction is halted and can be continued when power returns. Yes No N/A

Note: The ECR may continue to function while power is interrupted, (e.g., the ECR is equipped with an uninterruptible power supply.) Alternatively, the ECR may cease operation when power is interrupted and may resume the transaction in process at the time of the power failure when power is returned. Either alternative is acceptable provided that the ECR continues to function and perform correctly. There are no requirements to indicate when a power failure or interruption has occurred.

2.7. Provisions for Power Loss.

Note: For remote controllers, (e.g., cash register, console, etc.) which have the capability to retain information pertaining to a transaction, (e.g., stacked completed sales, if the information cannot be recalled at the dispenser following a power outage, (e.g., uninterruptible power supply or other means) then provisions must be made for the transaction information to be recalled and verified for at least 15 minutes following a power outage.

- 2.7.1. Remote controllers which stack completed sales must have a means to enable the transaction information to be recalled and verified for at least 15 minutes. Yes No N/A

Note: The criteria for power loss to a fuel dispenser are given in the retail motor fuel dispenser checklist.

- 2.8. An ECR shall be able to record all quantities, unit prices, and total prices up to the capacity of the dispenser. When the capacity of the quantity or total price is exceeded and the display "rolls over," the ECR shall not record the "rolled over" value but shall either record the correct total volume and total price or give an error indication. Yes No N/A

- 2.9. A cash register shall not print the values from a dispenser until the delivery has been completed and dispenser turned off. Yes No N/A

Items not measured or weighed may be split-priced according to general marketing practices. Acceptable price extensions will depend on individual State policies. Normally, the single item price will be the multiple item price divided by the number of items and rounded up to the next high cent. If the single item price is different from the price that would be computed as described, the price per item must be posted at the display. *See FPLA value comparison considerations and the Model Unit Pricing Regulation.* Suggested multiple item prices for test procedures are 3/\$1.00 and 7/\$1.00. The single item prices may be recorded as \$.34, \$.34, \$.32 or \$.34, \$.33, \$.33 and \$.15, \$.15, \$.15, \$.15, \$.15, \$.10 or \$.15, \$.14, \$.14, \$.15, \$.14, \$.14, \$.14, \$.14, respectively.

- 2.10. Price calculations for multiple-item-priced commodities shall be correctly computed as described above for:
- 2.10.1. Prices entered via PLUs. Yes No N/A
- 2.10.1. Prices entered through the keyboard. Yes No N/A

3. Recorded Representations

Code Reference: G-S.5.1., S.1.6.7., and S.1.6.8.

A sales receipt showing the quantity, unit price, total price, and product identity for each fuel delivery in a transaction is required for point-of-sale systems. A printed receipt must always be available to the customer upon request. In addition, systems may be equipped with the capability to issue an electronic receipt. The customer may be given the option to receive the receipt electronically (e.g., via cell phone, computer, etc.).

Various forms (or representations) of sales receipt formats are acceptable provided they are clear and understandable. Guidelines are provided to assist manufacturers and weights and measures officials in determining the acceptability of formats. Symbols other than those given below may be acceptable, but they will be reviewed on a case-by-case basis. More descriptive symbols and terms are acceptable.

- 3.1. The unit of measure shall be clearly defined. Acceptable symbols for units are: Gallon Gal, of G for gallons and Liter, l or L for liters. Upper or lower case is optional except that a lower case "l" must not resemble a "1" (numeral one), (e.g. a script "l" is an acceptable symbol for liters.) Yes No N/A

The unit of measure may be defined with either the quantity value, (e.g., 10 000 GAL) or with the unit price, (e.g., \$1.119/Gal), not necessarily both.

- 3.2. Acceptable designations of the unit price are: "@" as a prefix to the unit price value, an upper or lower case "X" or slash between the quantity and unit price, \$/G, PPG (price per gallon), PPL (price per liter), UP (unit price), P/G, price/Vol, PPU (price per unit), DOL/GAL. Yes No N/A
- 3.3. The total fuel price must be clearly distinguished from other information in the fuel transaction. To identify the total fuel sale price, use one of the following methods:
- 3.3.1. Decimal point in the proper dollar position, (e.g., XX.XX.) If a dollar sign is not used, there must be at least one offset column of the least significant digit in recorded information, other than the sale price. Yes No N/A
- 3.3.2. The words gas, diesel, or other product designation may be used with the word "SALE" (e.g., "FUEL SALE" or "GAS SALE") or the product identification followed by the sale price, (e.g., GAS 20.00.) Yes No N/A
- 3.4. Each fuel delivery in a transaction for a single customer must be recorded separately. Yes No N/A
- 3.5. Where a post-delivery discount(s) is applied, the sales receipt must provide: Yes No N/A
- the total quantity, unit price, and total computed price that were displayed on the dispenser at the end of the delivery prior to any post-delivery discount(s);
- an itemization of the post-delivery discounts to the unit price; and
- the final total price of each fuel sale after all post-delivery discounts are applied. *See LMD Code S.1.6.8.*
- 3.6. When a service station cash register/console is capable of recording sales transactions of other products, the fuel transaction must be clearly distinguished from the other transactions. A "product class" must be associated with the fuel transaction as well as the other transactions. In terms of format, the fuel transactions may be separated (blocked-off) from other transactions by blank lines or by at least one offset column between the sales price and the other recorded information. Yes No N/A
- 3.7. The product identity for fuel need only distinguish it from other items. The product name, code number (similar to a price look-up code), or hose or pump number are acceptable designations of product identify. *See LMD Code S.1.6.4.* Yes No N/A

Example 1		Example 2	
Meat	3.89	Meat	3.89
Soda	2.99	Soda	2.99
Gas 5.080 G @ 1.000	5.08	Gas 4.080 G @ 1.000	4.08
Cig	1.00		

Note: NIST Handbook 44 does not require that product identification, date, and change due be printed on a ticket or a cash register receipt. These requirements apply to recorded representations resulting from a final sale, not to deposit slips for prepaid transactions, etc.

- 3.8. The quantity representation of an item sold by count must be expressed in whole units. An expression of count with a decimal point and trailing zeroes, (e.g., 2.00 items) is acceptable provided that fractions of a whole unit cannot be expressed. Yes No N/A

4. Provisions for Sealing

Code Reference: G-S.8. Provision for Sealing Electronic Adjustable Components

Remote controllers, which have the capabilities to electronically adjust components that affect the performance of a device, shall have provisions for approved means of security. *See LMD - Appendix A - Philosophy for Sealing, Typical Features to be Sealed.*

THIS PAGE INTENTIONALLY LEFT BLANK

Appendix D/Sub-appendix H Action Items Table
October 5-6, 2012
NTETC Measuring Sector Meeting

Agenda Item	Title	Task	Responsible Person(s)	Due Date
1	Add Testing Criteria to NTEP Policy U “Evaluating electronic indicators submitted separate from a measuring element”	Finalize the checklist, addressing all highlighted areas and the five open	Work group	1/3/13
		Forward finalized checklist to Mike Frailer and Allen Katalinic for review.	Rich Miller, FMC; Technical Advisor, Marc Buttler	1/4/13
		Review finalized checklist and provide comments to Rich Miller and	Mike Frailer, MD; Allen Katalinic, NC	1/18/13
		Incorporate laboratory comments prior to 2013 NCWM Interim Meeting.	Rich Miller, FMC; Technical Advisor, Marc Buttler	1/23/13
2-4	Product Families Table	Research historical records for any information listing the various fluid product properties that were considered when the product families for PD and turbine meters were first drafted by Mel Hankel of Liquid Controls for the original Product	Technical Advisor, Marc Buttler	Completed 10/10/12
		Draft a specific proposal to update the Product Families Table for turbine and PD meters including the latest values for dynamic and kinematic viscosity if needed. Incorporate stakeholder input from labs, Rich	Dmitri Karimov, Liquid Controls	Next Sector meeting
5-9	See Summary	Submit recommendation to modify NCWM Publication 14 to NTEP Committee.	Technical Advisor, Marc Buttler	11/30/12
10	Post-Delivery Discounts and Electronic Receipts	Send advance draft copies of LMD and ECR checklist changes to Gordon Johnson and John Roach.	Technical Advisor, Marc Buttler	Completed 10/9/12
11	NCWM Pub 14, NTEP Administrative Policy Revision	Send all comments on the NCWM Pub 14, NTEP Administrative Policy draft revision to Jim Truex.	Sector members	Prior to 2013 NCWM Interim Meeting
12	Windshield Washer Fluid Vending Units	Discuss the issue with WI W&M.	Jim Truex, NCWM	TBD
13	Hot Water Meters	Discuss the merit of the item with water meter manufacturers.	Andre Noel, Neptune	Next Sector meeting
	Next Meeting	Identify location and time of next SWMA Meeting and propose location to NTEP Committee	Chair, NTEP Director, Technical Advisor	Completed 10/10/12

THIS PAGE INTENTIONALLY LEFT BLANK

National Conference on Weights and Measures / National Type Evaluation Program

Measuring Sector Attendee List Final

October 5-6, 2012 – Louisville, KY



Dennis Beattie
Measurement Canada
400 St Mary Ave
Winnipeg, Manitoba R1A 4K5
Canada
P. (204) 983-8910
E. dennis.beattie@ic.gc.ca

Jerry Butler
North Carolina Department of Agriculture
1050 Mail Service Center
Raleigh, NC 27699-1050
P. (919) 733-3313
E. jerry.butler@ncagr.gov

Marc Buttler
NIST, Office of Weights and Measures
100 Bureau Drive Stop 2600
Gaithersburg, MD 20899-2600
P. (301) 975-4615
E. marc.buttler@nist.gov

Rodney Cooper
Tuthill Transfer Systems
8825 Aviation Drive
Fort Wayne, IN 46809
P. (260) 755-7552
E. rcooper@tuthill.com

Michael Frailer
Maryland Weights and Measures
50 Harry S. Truman Parkway
Annapolis, MD 21401
P. (410) 841-5790
E. mike.frailer@maryland.gov

Paul Glowacki
Murray Equipment, Inc.
2515 Charleston Place
Fort Wayne, IN 46808
P. (260) 484-0382
E. pglowacki@murrayequipment.com

Gordon Johnson
Gilbarco, Inc.
7300 W. Friendly Ave
Greensboro, NC 27410
P. (336) 547-5375
E. gordon.johnson@gilbarco.com

Dmitri Karimov
Liquid Controls
105 Albrecht Drive
Lake Bluff, IL 60044
P. (847) 283-8317
E. dkarimov@idexcorp.com

Allen Katalinic
North Carolina Department of Agriculture
1050 Mail Service Center
Raleigh, NC 27699
P. (919) 733-3313
E. merleallen1234@aol.com

Michael Keilty
Endress + Hauser Flowtec AG USA
211 Pinewood Drive
Lyons, CO 80540
P. (303) 823-5796
E. michael.keilty@us.endress.com

Jack Kiefert
Honeywell Enraf
1545 Shagbark Way
Cumming, GA 30041
P. (404) 414-7523
E. jack.kiefert@honeywell.com

Andrew C. MacAllister
Daniel Measurement and Control Inc.
11100 Brittmoore Park Drive
Houston, TX 77041
P. (713) 827-4334
E. andrew.macallister@emerson.com

Rich Miller

FMC Technologies Measurement Solutions, Inc.
1602 Wagner Ave
Erie, PA 16510
P. (814) 898-5286
E. rich.miller@fmcti.com

Chris Willeke

Bright Solutions, LLC
631 4th Street North
Hudson, WI 54016
P. (651) 354-8211
E. chris.willeke@gmail.com

Henry Oppermann

Weights and Measures Consulting
1300 Peniston St.
New Orleans, LA 70115
P. (504) 896-9172
E. wm-consulting@att.net

Andre Noel

Neptune Technology Group Inc.
1600 Alabama Highway 229 South
Tallasse, AL 36078
P. (334) 283-7298
E. anoel@neptunetg.com

Ralph Richter

National Institute of Standards and Technology
100 Bureau Drive, Mailstop 2600
Gaithersburg, MD 20899-2600
P. (301) 975-3997
E. ralph.richter@nist.gov

John Roach

California Department of Food & Agriculture
6790 Florin-Perkins Road, Suite 100
Sacramento, CA 95828
P. (916) 229-3456
E. john.roach@cdfa.ca.gov

James Truex

National Conference on Weights and Measures
Inc.
88 Carryback Drive
Pataskala, OH 43062
P. (740) 919-4350
E. jim.truex@ncwm.net

Richard Tucker

RL Tucker Consulting LLC
605 Bittersweet Lane
Ossian, IN 46777
P. (260) 622-4243
E. rtucker83@comcast.net

Appendix E

National Type Evaluation Technical Committee (NTETC) Software Sector Meeting Summary

March 20-21, 2012
Columbus, Ohio

INTRODUCTION

The charge of the NTETC Software Sector is important in providing appropriate type evaluation criteria for software-based weighing or measuring device based on specifications, tolerances and technical requirements of NIST Handbook 44, *Specifications, Tolerances, and Other Technical Requirements for Weighing and Measuring Devices*, Section 1.10. General Code, Section 2 for weighing devices, Section 3 for liquid and vapor measuring devices, and Section 5 for taximeters, grain analyzers, and multiple dimension measuring devices. The Sector’s recommendations are presented to the National Type Evaluation Program (NTEP) Committee each January for approval and inclusion in NCWM Publication 14, *Technical Policy, Checklists, and Test Procedures*, for national type evaluation.

The Sector is also called upon occasionally for technical expertise in addressing difficult NIST Handbook 44 issues on the agenda of the National Conference on Weights and Measures (NCWM) Specifications and Tolerances (S&T) Committee. Sector membership includes industry, NTEP laboratory representatives, technical advisors and the NTEP Administrator. Meetings are held annually, or as needed and are open to all NCWM members and other registered parties.

Suggested revisions are shown in **bold face print** by ~~striking out~~ information to be deleted and underlining information to be added. Requirements that are proposed to be nonretroactive are printed in ***bold faced italics***.

Note: It is the policy of the National Institute of Standards and Technology (NIST) to use metric units of measurement in all of its publications; however, recommendations received by NCWM technical committees and regional weights and measures associations have been printed in this publication as submitted. Therefore, the report may contain references in inch-pound units.

Table A
Table of Contents

Title of Content	NTEP Appendix E – Page
INTRODUCTION	1
WELCOME/INTRODUCTIONS	2
STATUS REPORTS	2
1. 2012 NCWM Interim Meeting Report.....	2
2. 2012 International Activity Report	3
CARRY-OVER ITEMS	3
3. Software Identification/Markings	3
4. Identification of Certified Software	7
5. Software Protection/Security	11
6. Software Maintenance and Reconfiguration.....	14
7. NTEP Application for Software and Software-based Devices	16
8. Training of Field Inspectors.....	17
NEW ITEMS	19

9. Next Meeting 19
10. NCWM Publication 14 Proposed Changes 19
ATTENDANCE 20

Table B
Glossary of Acronyms and Terms

Acronym	Term	Acronym	Term
CC	Certificate of Conformance	OIML	International Organization of Legal Metrology
CRC	Cyclical Redundancy Check	OWM	Office of Weights and Measures
EPO	Examination Procedure Outline	PDC	Professional Development Committee
NCWM	National Conference on Weights and Measures	PTB	Physikalisch-Technische Bundesanstalt
NIST	National Institute of Standards and Technology	S&T	Specifications and Tolerances Committee
NTEP	National Type Evaluation Program	SMA	Scale Manufacturers Association
NTETC	National Type Evaluation Technical Committee	WELMEC	European Cooperation in Legal Metrology

Details of All Items
(In order by Reference Key)

WELCOME/INTRODUCTIONS

Mr. Pettinato, Chair, would like to welcome new individuals that have joined the NTETC Software Sector since the last meeting. Please welcome:

- Ms. Mary Abens, Emerson Process Management
- Mr. Thomas Fink, ITW Food Equipment/Hobart
- Mr. Adam Oldham, Gilbarco, Inc.

STATUS REPORTS

1. 2012 NCWM Interim Meeting Report

Source:

NCWM S&T Committee Agenda

Background/Discussion:

There was one item on the NCWM S&T Committee Agenda for the 2012 NCWM Interim Meeting related to work done by the NTETC Software Sector. Publication 15 (2012), S&T Item 360-2 relates to the 2012 NTETC Software Sector Agenda Item 1: Marking Requirements.

Conclusion:

Attendees indicated that the 2012 Interim Meeting was well attended. Most issues were not S&T issues – more laws and packaging type issues. The one issue that was on the S&T Committee Agenda has been changed from Informational to Developing. Mr. Truex, NTEP Administrator, was not at the Open Hearings when that item was discussed, but Mr. Lewis, Rice Lake Weighing Systems, Inc. was. He said it didn't go anywhere.

2. 2012 International Activity Report

Source:

NTETC Software Sector

Background/Discussion:

Dr. Thompson, National Institute of Standards and Technology (NIST), Office of Weights and Measures (OWM), will provide a synopsis of international activity that relates to the work of the Sector. Mr. Pettinato, Chair, will summarize the discussion that took place at the European Cooperation in Legal Metrology (WELMEC) WG 7 meeting in December 2011.

Conclusion:

Highlights of interest to the NTETC Software Sector:

- Workshop on Operating Systems in Legal Metrology hosted by Physikalisch-Technische Bundesanstalt (PTB) December 2011 coincident with WELMEC WG7 meeting.
- New D-11 draft circulated for comment early 2012.

Mr. Pettinato, Chair attended the WELMEC WG7 meeting in Berlin in December. He was struck by how similar the discussion was to our NCWM meetings. We are trailing in requirements for software security. They are trying to enforce authentication, identification, self-checking, etc. They're dealing with Linux and other open-source issues. Some approvals have taken 18 months. They seem to be starting in a new direction, possibly rewriting D 7.2 to reference software documents for IT standards for security. This would result in them only focusing on metrological issues in the software, leaving the other standards to cover the remaining issues in security. Currently PTB references a National Security Agency document on securing Red Hat Linux.

Mr. Beattie, Measurement Canada, asked about the feeling regarding Common Criteria. Mr. Pettinato reported that there were a couple presentations on this subject. There are big concerns about data privacy. PTB has backed off from this approach since they've realized that it puts a lot of responsibility on their plate. This is part of why they are looking to recommend various IT standards. Dr. Thompson reported that the Germans had wanted to go to the extreme of detailed code-walking. Mr. Oldham, Gilbarco, Inc., mentioned that though Europe has apparently backed off on this, India and Mexico appear to be continuing to pursue it.

CARRY-OVER ITEMS

3. Software Identification/Markings

Source:

NTETC Software Sector

Background/Discussion:

Since its inception, the Sector has wrestled with the issue of software identification and marking requirements. *See the 2011 Software Sector Meeting Summary and the 2012 Interim Meeting S&T Agenda Item 360-2 for more background on this item.*

NIST, OWM had been adding items to the S&T Agendas that confused matters since the perception was that this Sector had contributed to this input. Most of the confusion arose in the 1990s, due to some items being approved, and others, such as the definitions for “Built-for-Purpose” and “Not Built-for-Purpose,” not being approved.

Mr. Truex, NTEP Administrator, discussed the difficulty there has been in coming to a consensus on these issues with a representative of the NTEP Committee. Suggestions from NTEP to come to some resolution has been to write an article for the newsletter (which Mr. Bliss, Mettler-Toledo, LLC, had already done, to no effect), sending a questionnaire to the NTEP community, asking what they’d like to see, and sending a representative from this Sector to the S&T Committee.

Mr. Roach, California Division of Measurement Standards, is concerned that some people may want to interpret G-S.1.(c) as requiring a serial number for software. Mr. Lewis, Rice Lake Weighing Systems, Inc. pointed out that the computer that the software was running on could have the serial number, not the software itself. That shouldn’t matter, regardless.

Mr. Bliss, Mettler-Toledo, LLC, pointed out that the terminology in G-S.1. “All equipment”, could be interpreted to mean that it doesn’t apply to software. It was proposed that G-S.1.(c) be amended to add “and software”. Mr. Bliss suggested submitting a document explaining the reasoning behind the proposed changes, rather than assume that the text is self-explanatory. Making a presentation to the various Committees on the subject in addition would be beneficial as well. If a document is written, perhaps the examples given in G-S.1.d.3.(a) can be eliminated. “Metrologically significant” isn’t explicitly defined, but it’s been used since time immemorial.

Attempts to modify G-S.1.1. have been controversial, both in this meeting and in other Committees. Unfortunately, there has been little constructive feedback from the other Committees. It would probably be easier to incorporate specific examples given in G-S.1.1.b.3 in NCWM Publication 14. After some discussion, the previously proposed language was modified slightly to address some of the concerns received via feedback from other Sectors and interested parties:

NIST Handbook 44 – Proposed changes:

G-S.1. Identification. – All equipment, except weights and separate parts necessary to the measurement process but not having any metrological effect, shall be clearly and permanently marked for the purposes of identification with the following information:

- (a) the name, initials, or trademark of the manufacturer or distributor;
- (b) a model identifier that positively identifies the pattern or design of the device;
 - (1) *The model identifier shall be prefaced by the word “Model,” “Type,” or “Pattern.” These terms may be followed by the word “Number” or an abbreviation of that word. The abbreviation for the word “Number” shall, as a minimum, begin with the letter “N” (e.g., No or No.). The abbreviation for the word “Model” shall be “Mod” or “Mod.” Prefix lettering may be initial capitals, all capitals, or all lowercase.*
[Nonretroactive as of January 1, 2003]
(Added 2000) (Amended 2001)
- (c) *a nonrepetitive serial number, except for equipment with no moving or electronic component parts and ~~not built for purpose software based software devices~~ software;*
[Nonretroactive as of January 1, 1968]
(Amended 2003 and 20XX)
 - (1) *The serial number shall be prefaced by words, an abbreviation, or a symbol, that clearly identifies the number as the required serial number.*
[Nonretroactive as of January 1, 1986]
 - (2) *Abbreviations for the word “Serial” shall, as a minimum, begin with the letter “S,” and abbreviations for the word “Number” shall, as a minimum, begin with the letter “N” (e.g., S/N, SN, Ser. No., and S. No.).*
[Nonretroactive as of January 1, 2001]

- (d) ~~the current software version or revision identifier for not built for purpose software-based electronic devices;~~
[Nonretroactive as of January 1, 2004]

(Added 2003) **(Amended 20XX)**

- (1) *The version or revision identifier shall be prefaced by words, an abbreviation, or a symbol, that clearly identifies the number as the required version or revision.*

[Nonretroactive as of January 1, 2007]

(Added 2006)

- (2) *Abbreviations for the word “Version” shall, as a minimum, begin with the letter “V” and may be followed by the word “Number.” Abbreviations for the word “Revision” shall, as a minimum, begin with the letter “R” and may be followed by the word “Number.” The abbreviation for the word “Number” shall, as a minimum, begin with the letter “N” (e.g., No or No.).*

[Nonretroactive as of January 1, 2007]

(Added 2006)

- (3) The version or revision identifier shall be accessible via the display. Instructions for displaying the version or revision identifier shall be described in the CC. As an exception, permanently marking the version or revision identifier shall be acceptable under the following conditions:**

(a) The user interface does not have any control capability to activate the indication of the version or revision identifier on the display, or the display does not technically allow the version or revision identifier to be shown (analog indicating device or electromechanical counter) or

(b) the device does not have an interface to communicate the version or revision identifier.

- (e) an NTEP CC number or a corresponding CC Addendum Number for devices that have a CC.

- (1) *The CC Number or a corresponding CC Addendum Number shall be prefaced by the terms “NTEP CC,” “CC,” or “Approval.” These terms may be followed by the word “Number” or an abbreviation of that word. The abbreviation for the word “Number” shall, as a minimum, begin with the letter “N” (e.g., No or No.)*

[Nonretroactive as of January 1, 2003]

The required information shall be so located that it is readily observable without the necessity of the disassembly of a part requiring the use of any means separate from the device.

(Amended 1985, 1991, 1999, 2000, 2001, 2003, ~~and~~, 2006 **and 201X**)

G-S.1.1. Location of Marking Information for ~~Not-Built-For-Purpose~~ all Software-Based Devices. – For ~~not-built-for-purpose~~, software-based devices, either:

- (a) *The required information in G-S.1. Identification. (a), (b), ~~(d)~~, and (e) shall be permanently marked or continuously displayed on the device; or*

- (b) *The Certificate of Conformance Number shall be:*

(1) *permanently marked on the device;*

(2) *continuously displayed; or*

(3) *accessible through an easily recognized menu and, if necessary, a submenu. Examples of menu and submenu identification include, but are not limited to, “Help,” “System Identification,” “G-S.1. Identification,” or “Weights and Measures Identification.”*

Note: For (b), clear instructions for accessing the information required in G-S.1. (a), (b), and (d) shall be listed on the CC, including information necessary to identify that the software in the device is the same type that was evaluated.

[Nonretroactive as of January 1, 2004]

(Added 2003) (Amended 2006 **and 20XX**)

The new language in G-S.1.1. reflects that the Sector reached consensus on the following positions:

- The software version/revision should (with very few exceptions – see D-31 5.1.1) be accessible via the user interface.
- The means by which the software version is accessed must be described in the Certificate of Conformance (CC).

In addition, it was asserted that the previously recommended changes to G-S.1.1.(b)(3) in fact are not really necessary; the current language of NIST Handbook 44 empowers the laboratories to enforce “easily recognizable” as they see fit. In fact, the previously generated “list” of icons and menu options could certainly be used by the examining laboratories as part of the approval process (e.g., in NCWM Publication 14). Of course, a manufacturer who is reviewing NIST Handbook 44 so as to develop an acceptable device may benefit from more explicit guidance. Where does such guidance belong?

Comments related to the circulated list included a comment from the Scale Manufacturers Association (SMA) suggesting that a definition is needed for “software-based devices.” SMA opposed the definitions previously put forth by the Sector. It was suggested that perhaps SMA would be more amenable to a definition that doesn’t differentiate between software types.

The conclusion from the 2011 NTETC Software Sector Meeting was that the Sector will request feedback on the new recommended language for G-S.1. and G-S.1.1. since it does deviate somewhat from previous submissions. It is hoped that the various interested Sectors, regions, and associations will give this new proposal careful thought and submit their concerns to the NTETC Software Sector.

The list of suggested icons/menus that should be considered finite options for manufacturers was updated to reflect comments received by the Sector. The Sector now believes this approach is adequate without a change to NIST Handbook 44; the NTEP laboratories would be able to enforce “easily recognizable” against this finite list. Hence, the Sector recommends the list be inserted into NCWM Publication 14.

Crafting a definition for “software based device” may be included as an item in a future agenda. Note the term “not built for purpose, software based device” is already used in NIST Handbook 44.

Some concerns seemed to stem from a lack of understanding of intent. It was suggested that a supplementary document could be written, explaining the intent of the “software based device” terminology.

Conclusion:

The Sector wishes to continue promotion of this item, with the minor edits shown above included addressing some of the concerns of other interested parties. Since this is currently defined as a Developing Item, it cannot be moved to a Voting Item at the 2012 NCWM Annual Meeting; it will have to wait until 2013. In January of 2013, the decision will be made as to changing the status of this item. This Sector will need to push to accomplish this. Developing a presentation and/or writing a supplementary document that would explain the intent behind the proposed changes to G-S.1. and G-S1.1. would most likely help in getting these changes passed. The annual meeting would be an appropriate venue for a presentation, though it may be too late to get it onto the agenda. The SMA is having their meeting next month in Monterey, California. Mr. Fink, ITW Food Equipment/Hobart, may be available to assist Mr. Pettinato, Chair, in putting together a presentation and volunteered to present it at the SMA Meeting.

4. Identification of Certified Software

Source:

NTETC Software Sector

Background/Discussion:

This item originated as an attempt to answer the question, “How does the field inspector know that the software running in the device is the same software evaluated and approved by the lab?” In previous meetings it was shown that the international community has addressed this issue (both WELMEC and International Organization of Legal Metrology [OIML]).

From WELMEC 7.2:

Required Documentation:

The documentation shall list the software identifications and describe how the software identification is created, how it is inextricably linked to the software itself, how it may be accessed for viewing, and how it is structured in order to differentiate between version changes with and without requiring a type approval.

From OIML D-31:

The executable file “**tt100_12.exe**” is protected against modification by a checksum. The value of checksum as determined by algorithm **XYZ** is **1A2B3C**.

Previous discussions have included a listing of some additional examples of possible valid methods (not limiting):

- Cyclical Redundancy Check (CRC)
- Checksum
- Inextricably Linked version no.
- Encryption
- Digital Signature

Is there some method to give the weights and measures inspector information that something has changed?

Yes, the Category III Audit Trail or other means of sealing.

How can the weights and measures inspector identify an NTEP certified version?

They can't, without adding additional requirements such as those described here, in conjunction with including the identifier on the CC.

The Sector has continued to believe that we should work towards language that would include a requirement similar to the OIML requirement in NIST Handbook 44. It is also the opinion of the Sector that a specific method should not be defined; rather the manufacturer should utilize a method and demonstrate the selected identification mechanism is suitable for the purpose. It is not clear from the discussion where such proposed language might belong.

Closely related to this concept of uniquely identifying software is the practice of software separation. The Sector sees the benefit in allowing that metrological software be separated from non-metrological software for ease of identification and evaluation.

From OIML:

Separation of software parts – All software modules (programs, subroutines, objects, etc.) that perform metrologically significant functions or that contain metrologically significant data domains form the metrologically significant software part of a measuring instrument (device or sub-assembly). The conformity requirement applies to all parts and parts shall be marked according to Section G-S-X.X.

If the separation of the software is not possible or needed, then the software is metrologically significant as a whole.

(Segregation of parameters is currently allowed – see table of sealable parameters)

Previously recommended text intended to be added to NCWM Publication 14 was discussed and modified slightly:

Identification of Certified Software:

Note: Manufacturers may choose to separate metrologically significant software from non-metrologically significant software. Separation would allow the revision of the non-metrological portion without the need for further evaluation. In addition, non-metrologically significant software may be updated on devices without breaking a seal, if so designed. Separation of software requires that all software modules (programs, subroutines, objects, etc.) that perform metrologically significant functions or that contain metrologically significant data ~~domains~~ form the metrologically significant software part of a measuring instrument (device or sub-assembly). If the separation of the software is not possible or needed, then the software is metrologically significant as a whole. ~~The conformity requirement applies to all parts and parts shall be marked according to Section G-S-X.X.~~

The manufacturer must describe and possibly demonstrate how the version or revision identifier is directly and inseparably linked to the metrologically significant software. Where the version revision identifier is comprised of more than one part, the manufacturer shall describe which portion represents the metrological significant software and which does not.

From OIML D-31:

Legally relevant software of a measuring instrument/electronic device/sub-assembly shall be clearly identified with the software version or another token. The identification may consist of more than one part but at least one part shall be dedicated to the legal purpose.

The identification shall be inextricably linked to the software itself and shall be presented or printed on command or displayed during operation or at start up for a measuring instrument that can be turned off and on again. If a sub-assembly/an electronic device has neither display nor printer, the identification shall be sent via a communication interface in order to be displayed/printed on another sub-assembly/electronic device.

The first sentence of the first paragraph above is already addressed in NIST Handbook 44's marking requirements.

In 2010, the Sector recommended the following change to NIST Handbook 44, General Code, G-S.1.(d) to add a new subsection (3):

(d) the current software version or revision identifier for ~~not built for purpose~~ software-based electronic devices;

[Nonretroactive as of January 1, 2004]

*(Added 2003) **(Amended 20XX)***

(1) The version or revision identifier shall be prefaced by words, an abbreviation, or a symbol, that clearly identifies the number as the required version or revision.

[Nonretroactive as of January 1, 2007]

(Added 2006)

(2) Abbreviations for the word "Version" shall, as a minimum, begin with the letter "V" and may be followed by the word "Number." Abbreviations for the word "Revision" shall, as a minimum, begin with the letter "R" and may be followed by the word "Number." The abbreviation for the word "Number" shall, as a minimum, begin with the letter "N" (e.g., No or No.).

[Nonretroactive as of January 1, 2007]

(Added 2006)

(3) The version or revision identifier shall be directly and inseparably linked to the software itself. The version or revision identifier may consist of more than one part, but at least one part shall be dedicated to the metrologically significant software.
[Nonretroactive as of January 1, 201X]
(Added 20XX)

Also the Sector recommends the following information be added to NCWM Publication 14 as explanation/examples:

- Unique identifier must be displayable/printable on command or during operation, etc.
- At a minimum, a version/revision indication (1.02.09, rev 3.0 a, etc). Could also consist of/contain checksum, etc (crc32, for example)

There was some additional discussion on this item regarding where this new requirement was best located. It was suggested that the first sentence of G-S.1.d.(3) could be added as a clause to the base paragraph G-S.1(d) text, e.g.

“the current software version or revision identifier for ~~not built for purpose software-based~~ devices, which shall be directly and inseparably linked to the software itself;” .

It also was suggested that the second sentence in G-S.1.d. (3) might be more suitable for NCWM Publication 14, as it describes more “how” than “what” the requirement entails.

In addition, the Sector considered the following information to be added to NCWM Publication 14 as explanation/examples:

- The current software identifier must be displayable/printable on command during operation (or made evident by other means deemed acceptable by G-S.1.)
- At a minimum, the software identifier must include a version/revision indication (1.02.09, rev 3.0 a, etc.). It could also consist of/contain checksum, etc. (crc32, for example).
- The version or revision identifier may consist of more than one part, but at least one part shall be dedicated to the metrologically significant software.

Other questions still outstanding are:

- If we allow hard-marking of the software identifier (the Sector has wavered on this in the past), does the above wording then imply that some mechanical means is required (i.e. physical seal) to “inseparably link” the identifier to the software? If it’s acceptable to hard-mark the version or revision, the requirement to inseparably link it to the software is waived.
- If a device is capable of doing so, does it still have to be able to display, print or communicate the identifier somehow, even if it is hard-marked? If the device is capable of doing so, it must.

At the 2012 NTETC Software Sector Meeting, there was some discussion as to where the terminology regarding inextricably linking the software version or revision to the software itself belonged. At the moment, it is not incorporated in the proposed text for G-S.1. NCWM Publication 14 may be a better option for the time being. This would be another item that would benefit from further explanation in a supplementary document.

One suggestion was this revision to G-S.1.(d):

- (d) ~~when metrologically significant software is employed, the current software version or revision identifier, which shall be directly and inseparably linked to the software itself, for not built for purpose software-based electronic devices;~~

Alternatively, if the previously proposed new subsection G-S.1.(d)(3) from Item 1 is adopted, this concept could be inserted thus:

(3) The version or revision identifier shall be directly and inseparably linked to the software itself and accessible via the display. Instructions for displaying the version or revision identifier shall be described in the CC. As an exception, permanently marking the version or revision identifier shall be acceptable under the following conditions:

Several sector members were of the opinion that attempting to make this change at the same time as the earlier changes might be a difficult sell. Mr. Truex, NTEP Administrator, reiterated the necessity of baby steps.

Conclusion:

The Sector recommends adding the following to NCWM Publication 14 and forward to NTETC Weighing, Measuring, and Grain Analyzer Sectors for feedback:

Identification of Certified Software:

Note: Manufacturers may choose to separate metrologically significant software from non-metrologically significant software. Separation would allow the revision of the non-metrological portion without the need for further evaluation. In addition, non-metrologically significant software may be updated on devices without breaking a seal, if so designed. Separation of software requires that all software modules (programs, subroutines, objects etc.) that perform metrologically significant functions or that contain metrologically significant data domains form the metrologically significant software part of a measuring instrument (device or sub-assembly). If the separation of the software is not possible or needed, then the software is metrologically significant as a whole. The conformity requirement applies to all parts and parts shall be marked according to Section G-S-X.X.

The manufacturer must describe and possibly demonstrate how the version or revision identifier is directly and inseparably linked to the metrologically significant software. Where the version revision identifier is comprised of more than one part, the manufacturer shall describe which portion represents the metrological significant software and which does not.

Also, it was decided to forward the two alternate options for adding requirements for uniquely identifying software to the individual Sectors:

One suggestion was this revision to G-S.1.d:

(d) ~~when metrologically significant software is employed,~~ the current software version or revision identifier, which shall be directly and inseparably linked to the software itself, ~~for not built for purpose software-based electronic devices;~~

Alternatively, if the previously proposed new subsection G-S.1.(d)(3) from Item 1 is adopted, this concept could be inserted thus:

(3) The version or revision identifier shall be **directly and inseparably linked to the software itself and accessible via the display. Instructions for displaying the version or revision identifier shall be described in the CC. As an exception, permanently marking the version or revision identifier shall be acceptable under the following conditions:**

Both alternatives will be sent to the Sectors for feedback.

5. Software Protection/Security

Source:

NTETC Software Sector

Background/Discussion:

The Sector agreed that NIST Handbook 44 already has audit trail and physical seal, but these may need to be enhanced.

From the WELMEC Document:

Protection against accidental or unintentional changes

Metrologically significant software and measurement data shall be protected against accidental or unintentional changes.

Specifying Notes:

Possible reasons for accidental changes and faults are: unpredictable physical influences, effects caused by user functions and residual defects of the software even though state of the art of development techniques have been applied.

This requirement includes consideration of:

- a) Physical influences: Stored measurement data shall be protected against corruption or deletion when a fault occurs or, alternatively, the fault shall be detectable.
- b) User functions: Confirmation shall be demanded before deleting or changing data.
- c) Software defects: Appropriate measures shall be taken to protect data from unintentional changes that could occur through incorrect program design or programming errors, for example, plausibility checks.

Required Documentation:

The documentation should show the measures that have been taken to protect the software and data against unintentional changes.

Example of an Acceptable Solution:

- The accidental modification of software and measurement data may be checked by calculating a checksum over the relevant parts, comparing it with the nominal value and stopping if anything has been modified.
- Measurement data are not deleted without prior authorization, for example, a dialogue statement or window asking for confirmation of deletion.
- For fault detection see also Extension I.

The Sector continued to develop a proposed checklist for NCWM Publication 14. The numbering will still need to be added. This is based roughly on R 76 – two checklist and discussions beginning as early as the October 2007 NTETC Software Sector Meeting. The information requested by this checklist is currently voluntary, however, it is recommended that applicants comply with these requests or provide specific information as to why they may not be able to comply. Based on this information, the checklist may be amended to better fit with NTEP's need for information and the applicant's ability to comply.

The California, Maryland and Ohio laboratories agreed to use this check list on one of the next devices they have in the laboratory and report back to the Sector on what the problems may be. In February 2011, the North Carolina laboratory was also given a copy of the check list to try.

1. Devices with Embedded Software TYPE P (aka built-for-purpose)

- 1.1. Declaration of the manufacturer that the software is used in a fixed hardware and software environment. **AND Needs clarification** Yes No N/A
- 1.2. Cannot be modified or uploaded by any means after securing/verification. Yes No N/A
Note: It is acceptable to break the "seal" and load new software, audit trail is also a sufficient seal.
- 1.3. The software documentation contains:
- 1.3.1. Description of all functions, designating those that are considered metrologically significant. Yes No N/A
- 1.3.2. Description of the **securing** means **of sealing** (evidence of an intervention). **(Note: See Philosophy of Sealing in Pub. 14.)** Yes No N/A
- 1.3.3. Software Identification Yes No N/A
- 1.3.4. Description how to check the actual software identification. Yes No N/A
- 1.4. The software identification is:
- 1.4.1. Clearly assigned to the metrologically significant software and functions. **Describe how the identification applies to the software – is the metrological software separated or does the identifier apply to the entire software?** Yes No N/A
- 1.4.2. Provided by the device as documented. Yes No N/A

2. Personal Computers, Instruments with PC Components, and Other Instruments, Devices, Modules, and Elements with Programmable or Loadable Metrologically Significant Software TYPE U (aka not built-for-purpose)

- 2.1. The metrologically significant software is:
- 2.1.1. Documented with all relevant (see below for list of documents) information. **This may be part of the standard documentation, or it may be a separate document.** Yes No N/A
- 2.1.2. Protected against accidental or intentional changes. **Can someone overwrite it or modify it after it's been installed without any evidence of a change?** Yes No N/A
- 2.2. Evidence of intervention (such as, changes, uploads, circumvention) is available until the next verification / inspection (e.g., physical seal, Checksum, CRC, audit trail, etc. means of security). Yes No N/A

3. Software with Closed Shell (no access to the operating system and/or programs possible for the user). Shell means command-line interface or access to the Windows Desktop, as examples. This doesn't guarantee that there is no back door, just that the manufacturer doesn't know of one.

- 3.1. Check whether there is a complete set of commands (e.g., function keys or commands via external interfaces) supplied and accompanied by short descriptions. Yes No N/A
- 3.2. Check whether the manufacturer has submitted a written declaration of the completeness of the set of commands. Yes No N/A

4. Operating System and / or Program(s) Accessible for the User

- 4.1. Check whether a checksum or equivalent signature is generated over the machine code of the metrologically significant software (program module(s) subject to legal control Weights and Measures jurisdiction and type-specific parameters). **Is there a means to determine that the software is complete and authorized by the vendor – not damaged or someone else’s program?** Yes No N/A
- 4.2. Check whether the metrologically significant software will detect and act upon any unauthorized alteration of the metrologically significant software using simple software tools (e.g., text editor). **If the software is altered, is there some means to determine whether that has occurred? As an example, can an average text editor cause damage?** Yes No N/A

5. Software Interface(s)

- 5.1. **This is intended to determine whether the manufacturer has at least considered these issues.** Verify the manufacturer has documented:
- 5.1.1. The program modules of the metrologically significant software are defined and separated. **Has the metrologically significant software been separated from the other software?** Yes No N/A
- 5.1.2. The protective software interface itself is part of the metrologically significant software. **This is something that’s used to close access to the metrologically significant software.**
- 5.1.3. The functions of the metrologically significant software that can be accessed via the protective software interface. **This could be all, none, or some. Functions mean more than just changing parameters. As an example, this may mean whether you can take a tare or not.** Yes No N/A
- 5.1.4. The parameters that may be exchanged via the protective software interface are defined. **The sealed parameter list from Pub. 14.** Yes No N/A
- 5.1.5. The description of the functions and parameters are conclusive and complete. Yes No N/A
- 5.1.6. There are software interface instructions for the third party (external) application programmer. **If so, how is the metrologically-significant data and functionality protected? What can it do? Is it fixed? Can it be expanded?** Yes No N/A

The Maryland laboratory had particular questions regarding 3.1. and 5.1. The information for 3.1. could be acquired from an operator’s manual, a training video, or in-person training. The items in 5.1. were confusing to the evaluators. The terminology is familiar to software developers, but not necessarily others. It was indicated that manufacturers were typically quick to return the filled out questionnaire, but he didn’t know how his laboratory was supposed to verify that it was true. Generally, the laboratories wouldn’t be expected to verify things to that level. For example, if the manufacturer states that a checksum is used to ensure integrity, the laboratories wouldn’t be expected to evaluate the algorithm used.

The intent was to see whether the manufacturer had at least considered these issues, not for evaluators to become software engineers. Perhaps a glossary or descriptive paragraphs might be added to assist the evaluators for if the manufacturer has questions for the evaluators.

OIML makes use of supplementary documents to explain the checklist they use. Below are links:

- <http://www.oiml.org/publications/D/D031-e08.pdf>
- <http://www.welmec.org/latest/guides/72.html>
- http://www.welmec.org/fileadmin/user_files/publications/2-3.pdf

WELMEC document 2.3 is the original source for our checklist, but it's been significantly revised and simplified. Mr. Payne, Maryland Department of Agriculture, is going to review the other documents and come up with some suggestions for the checklist. Mr. Roach, California Division of Measurement Standards, is going to begin using the checklist. The international viewpoint is that any device running an operating system is considered to be Type U. Mr. Roach mentioned that they're having lots of problems with "skimmers" stealing PIN's. Is there some way they can detect this?

Mr. Lewis, Rice Lake Weighing Systems, Inc., mentioned that he liked Measurement Canada's website. When answering similar questions, different pages would appear, based on answers to those questions: <http://www.ic.gc.ca/eic/site/mc-mc.nsf/eng/lm00573.html>

At the 2011 NTETC Software Sector Meeting, the laboratories were polled to obtain any feedback on the use of the checklist. Maryland attempted to use this checklist a few times. They had some difficulty obtaining answers from the manufacturers because the individual(s) interacting with the Maryland evaluator didn't always have the required information on hand. More experience in using the checklist will help determine what needs to be revised.

It was suggested that the checklist could be sent to manufacturers for their feedback as well, with the stipulation that it is a completely voluntary exercise and purely informational at this point. The laboratories will coordinate with willing manufacturers to obtain feedback.

Conclusion:

Work is ongoing on this item with the intent that it eventually will be incorporated as a checklist in NCWM Publication 14; again the laboratories are requested to try utilizing this checklist for any evaluations on software-based electronic devices.

The checklist has been reviewed with an eye to making its terminology clearer to laboratories. Some examples and clarifications have been added as shown in the discussion section of this item. The revised checklist will be distributed to the laboratories for additional review. Maryland and California laboratories agreed to use the checklist on a trial basis.

6. Software Maintenance and Reconfiguration

Source:

NTETC Software Sector

Background/Discussion:

After the software is completed, what do the manufacturers use to secure their software? The following items were reviewed by the Sector.

1. Verify that the update process is documented.
2. For updates to be automatically verified by the device, installed software must be authenticated and checked for integrity.

Technical means shall be employed to guarantee the authenticity of the loaded software (i.e., that it originates from the owner of the type approval certificate). This can be accomplished (e.g., by cryptographic means such as signing). The signature is checked during loading. If the loaded software fails this test, the instrument shall discard it and either use the previous version of the software **or become inoperative.**

Technical means shall be employed to guarantee the integrity of the loaded software (i.e., that it has not been inadmissibly changed before loading). This can be accomplished for example, by adding a checksum or hash code of the loaded software and verifying it during the loading procedure. If the loaded software fails this test, the instrument shall discard it and either use the previous version of the software **or become inoperative**.

3. Verify that the sealing requirements are met
This item is **only** addressing the **software update**, it can be either verified or traced.
4. Verify that if the upgrade process fails, the device is inoperable or the original software is restored.
The question before the group is can this be made mandatory, in other words.

“The manufacturer shall ensure by appropriate technical means (e.g., an audit trail) that traced updates of metrologically significant software are adequately traceable within the instrument for subsequent verification and surveillance or inspection. This requirement enables inspection authorities, which are responsible for the metrological surveillance of legally controlled instruments, to back-trace traced updates of metrologically significant software over an adequate period of time (that depends on national legislation).”

The Sector discussed how to best move this item forward, and there was also some discussion as to whether new language for the General Code was required. The general consensus of the group after considering feedback from external interested parties is that a new G-S.9. with explicit requirements is not necessary (nor likely to be adopted by NCWM) and that this requirement belongs in the NCWM Publication 14 lists of sealable parameters rather than in NIST Handbook 44.

Additional work done at the 2011 NTETC Software Sector Meeting to further develop the proposed text toward inclusion in NCWM Publication 14 resulted in the following:

The updating of metrologically significant software shall be considered a sealable event. The software that checks for authenticity and integrity for a Traced Update, as well as the software responsible for generating and viewing the audit trail, is metrologically significant.

Verified Update

A verified update is the process of installing new software where the security is broken and the device must be re-verified. Checking for authenticity and integrity is the responsibility of the owner/user.

Traced Update

A traced update is the process of installing new software where the software is automatically checked for authenticity and integrity, and the update is recorded in a ~~software update log or~~ Category 3 audit trail. The audit trail entry shall include the software identification of the newly installed version.

Note: It's possible that the Philosophy of Sealing section of NCWM Publication 14 may already address the above IF the definitions of Verified and Traced Updates (and the statement below) were to be added. The contrary argument was that it may be better to be explicit:

Conclusion:

As a first step, attempt to add only the following to the Philosophy of Sealing in NCWM Publication 14:

The updating of metrologically significant software, including software that checks the authenticity and integrity of the updates, shall be considered a sealable event.

Mr. Truex, NTEP Administrator, believes the above sentence is unnecessary since it's self-evident. It was agreed to ask the Sectors for feedback on the value of this addition.

Though the Sector is currently recommending only the single sentence be incorporated into NCWM Publication 14 for the time being, ultimately, the Sector may wish to advance the remaining language of the original item submission.

7. NTEP Application for Software and Software-based Devices

Source:

NTETC Software Sector

Background/Discussion:

The purpose of initiating this item was to identify issues, requirements and processes for type approving software applications. It was suggested that it may be useful to the laboratories to devise a separate submission form for software and devices. What gets submitted? What requirements and mechanisms for submission should be available? Validation in the laboratories - all required subsystems shall be included to be able to simulate the system as installed.

Mr. Roach, California Division of Measurement Standards, stated that if the software package being evaluated supports platforms/subsystems from multiple manufacturers, testing should be done using at least two platforms/subsystems. Scale laboratories and scale manufacturers indicated that this is not usually done for scale evaluations.

Mr. Truex, NTEP Administrator, indicated that we can move in this direction, but felt that it was somewhat premature to develop this thoroughly now. At the point where the Sector has developed checklist requirements, then we could move to perhaps add a subsection to current NTEP applications for applicable software. Refer to D-31.6.1. It was also agreed that there seems to be no reason for limiting the scope of this item to software-only applications, and hence all software/software-based devices could benefit from an enhanced application process. Hence the description of this agenda item was modified as shown in the marked up heading.

Comments given at the meeting indicate that current practice does not require anything different for software/software based devices compared to any other type approval. It was also noted that for international applications, OIML D-31.6.5 states, "The approval applicant is responsible for the provision of all the required equipment and components." This would likely also be the policy of NTEP.

Mr. Truex, NTEP Administrator, clarified that the current applications have some checks of software already, not that they couldn't benefit eventually from some additions. Once the checklist has been refined, it might prove useful. This won't likely be a separate software checklist but rather some additional questions that will pertain to software, added to the existing list of questions that are currently asked.

Since the checklist is still being tried out by some of the laboratories, the Sector is not quite ready to develop this fully. Some documentation that eventually might be required by applicants could include (from WELMEC doc. 7-2 Issue 4):

- A description of the software functions that are metrologically significant, meaning of the data, etc.
- A description of the accuracy of the measuring algorithms (e.g., price calculation and rounding algorithms).
- A description of the user interface, menus, and dialogs.
- The software identification (version, revision, etc.) and how to view it.
- An overview of the system hardware (e.g., topology block diagram, type of computer(s), type of network), if not described in the operating manual.
- An overview of the security aspects of the operating system, e.g. protection, user accounts, privileges, etc.
- The operating manual.

Conclusion:

These documentation requirements will be considered as input for requirements that will eventually appear in NCWM Publication 14 and the application paperwork. Further work by the Sector to develop the NCWM Publication 14 requirements is needed, after more input from the laboratories is gathered.

8. Training of Field Inspectors

Source:

NTETC Software Sector

Background/Discussion:

During discussions at the 2009 NTETC Software Sector Meeting, the Sector concluded that a new agenda item should be initiated specific to the training of field inspectors in relation to evaluating/validating software-based devices.

California has an Examination Procedure Outline (EPO) that begins to address this. Use NIST Handbook 112* as a pattern template for how it could read.

Items to be addressed:

- CC
- Terminology (as related to software) beyond what is in NIST Handbook 44.
- Reference materials / information sources
- Safety

System Verification Tests

NOTE: Item numbers one through five applies to both weighing and measuring devices. Numbers six and seven are specific to weighing devices; while numbers nine and ten apply to measuring devices.

1. Identification. The identification (ID) tag may be on the back room computer server and could be viewed on an identification screen on the computer monitor. The ID information may be displayed on a menu or identification screen. Though currently discouraged, some systems may be designed so the system must be shut down and reset to view the ID information. G-S.1. (1.10.)
 - 1.1. Manufacturer.
 - 1.2. Model designation.
2. Provisions for sealing. G-S.8. [1.10.]; S.1.11. [2.20.]; S.2.2. [3.30.]
 - 2.1. Verify sealing category of device (refer to Certificate of Approval for that system).
 - 2.2. Verify compliance with certificate.
3. Units of measure.
 - 3.1. A computer and printer interfaced to a digital indicator shall print all metrological values, intended to be the same, identically. G-S.5.2.2.(a); G-S.5.1. [1.10.]
 - 3.2. The unit of measure, such as lb, kg, oz, gal, qt, liters, or whatever is used, must agree.
4. Operational controls, indications and features (buttons and switches). Verify that application criteria and performance criteria are met (refer to Certificate of Approval).
 - 4.1. Any indication, operation, function or condition must not be represented in a manner that interferes with the interpretation of the indicated or printed values.
5. Indications and displays.
 - 5.1. Attempt to print a ticket. The recorded information must be accurate or the software must not process and print a ticket with erroneous data interpreted as a measured amount.

Weighing Devices

6. Motion detection.
 - 6.1. For railway track, livestock, and vehicle scales apply or remove a test load of at least 15d while simultaneously operating a print button, push-button tare or push-button zero. A good way to do this is to try to print a ticket while pulling the weight truck or another vehicle onto the scale. Recorded values shall

not differ from the static display by more than 3d. Perform the test at 10 %, 50 % and 100 % of the maximum applied test load. S.2.5.1.(a) [2.20.]; EPO NO. 2-3, 2.4

6.2. For all other scales, apply or remove at least 5d. Printed weight values must agree with the static weight within 1d and must exactly agree with other indications. S.2.5.4.(b) [2.20.]; EPO NO. 2-3, 2.4

7. Behind zero indication.

7.1 Apply a load in excess of the automatic zero setting mechanism (AZSM) and zero the scale. S.2.1.3. [2.20.]; EPO NO. 2-3, 2.4, 2.5.2

Example: On a vehicle scale have someone stand on the scale, then zero them off (AZSM is 3d). Remove the weight (person) and note the behind zero display (usually a minus weight value) or error condition.

7.2. Attempt to print a ticket. With a behind zero condition, (manually or mechanically operated) a negative number must not be printed as a positive value.

8. Over capacity.

8.1. Manually enter a gross weight if permissible or apply a test load in excess of 105 % of the scale's capacity. S.1.7. [2.20.]; S.1.12., UR.3.9. [2.20.]

8.2. Attempt to print a weight ticket. A system must not print a ticket if the manually entered weight or load exceeds 105 % of the scale capacity.

Measuring Devices

9. Motion detection.

9.1. Initiate flow through the measuring element. Attempt to print a ticket while the product is flowing through the measuring chamber. The device must not print while the indication is not stable. S.2.4.1. [3.30.]

10. Over capacity.

10.1. Attempt to print a ticket in excess of the indicated capacity. A system must not print a ticket if the device is manually or mechanically operated in excess of the indicated value.

NOTE: Be aware of error codes on the indicator, which may be interrupted as measured values.

This item is in the early stages; work will continue on the item working toward materials to aid in the training of field inspectors. It was indicated that working in conjunction with the Professional Development Committee (PDC) to develop training materials, etc. would be a logical path of progress once we have developed the information content to include.

At the 2011 NTETC Software Sector Meeting, it was decided that this topic should be tabled until items 1 to 4 in the summary are better defined. This will also depend on the needs of and feedback from field inspectors, since the goal is to empower them to be better able to handle inspection of software-based devices. It was also suggested that we liaise with the PDC to garner input for focus areas related to the inspection of software-based devices. It was also noted that OIML D 31 has sections on conformance to original type approval, etc., pertaining to software.

Conclusion:

Mr. Jordan, California Division of Measurement Standards, is already doing something similar, and he may be able to assist. Mr. Roach, California Division of Measurement Standards, will talk to him to see whether they're available. In addition Mr. Parks, California Division of Measurement Standards, is based in Sacramento, California, and a potential resource. If the meeting is held in Sacramento next year, they may be able to attend.

Mr. Truex, NTEP Administrator, pointed out that the PDC would also be a valuable resource on this subject. Mr. Pettinato, Chair, will contact them.

**NIST Handbook 112- Examination Procedure Outline for Commercial Weighing and Measuring Devices.*

NEW ITEMS

9. Next Meeting

Source:

NTETC Software Sector

Background/Discussion:

The Sector is on a yearly schedule for NTETC Software Sector Meetings. Mr. Truex, NTEP Administrator, will determine when the next meeting is possible. The normal rotation would have the meeting in Sacramento, California in 2013.

Mr. Truex, NTEP Administrator, indicated that New York has re-established their laboratory, and would be an alternative site for the 2013 meeting. It was also mentioned that Sacramento had the benefit of Mr. Jordan, California Division of Measurement Standards, and/or Mr. Parks, California Division of Measurement Standards, being able to attend.

Conclusion:

The next meeting will be held either in Albany, New York, or Sacramento, California, depending on New York's willingness to host and locate an acceptable meeting location. Mr. Truex, NTEP Administrator, will make the determination as to meeting location by the end of the year.

10. NCWM Publication 14 Proposed Changes

Source:

NTEP Administrator

Background/Discussion:

Mr. Truex, NTEP Administrator, sent the Sector membership a document outlining proposed changes to NCWM Publication 14's *Administrative Policy* section. The purpose is not to change the intent but to clarify it. He's asking for feedback on the proposed changes. Is the formatting, verbage, etc. acceptable? Does anyone have any questions or concerns? If so, send them to Mr. Truex. After the Sectors have reviewed it, NTEP will do so, and then it will go to the Board of Directors.

Conclusion:

Members are asked to review and comment on the document and provide any feedback to the Mr. Truex, NTEP Administrator.

ATTENDANCE

Dennis Beattie

Measurement Canada
400 St. Mary Ave
Winnipeg, MB R3C 4K5
Canada
(204) 983-8910
dennis.beattie@ic.gc.ca

Doug Bliss

Mettler-Toledo, Inc.
1150 Dearborn Drive
Worthington, OH 43085
(614) 438-4307
doug.bliss@mt.com

Cassie Eigenmann

DICKEY-john Corporation
5200 Dickey-john Road
Auburn, IL 62615
(217) 438-2294
ceigenmann@dickey-john.com

Tom Fink

Hobart Corporation
701 Ridge Ave
Troy, OH 45374
(937) 332-3114
tom.fink@hobartcorp.com

Mike Frailer

Maryland Weights and Measures
50 Harry S Truman Parkway
Annapolis, MD 21401
(410) 841-5790
frailerm@mda.state.md.us

Teri Gulke

Liquid Controls, LLC
105 Albrecht Drive
Lake Bluff, IL 60044
(847) 283-8346
tgulke@idexcorp.com

Ken Jones

California Division of Measurement Standards
6790 Florin Perkins Road
Suite 100
Sacramento, CA 95828
(916) 229-3052
ken.jones@cdfa.ca.gov

Tom Junkans

Rice Lake Weighing Systems
230 West Coleman Street
Rice Lake, WI 54868
(715) 434-5130
tjunkans@ricelake.com

Paul A. Lewis, Sr.

Rice Lake Weighing Systems, Inc.
230 West Coleman Street
Rice Lake, WI 54868
(715) 434-5322
plewis@ricelake.com

Rick Lydon

Sick, Inc.
800 Technology Center Drive
Stoughton, MA 02072
(781) 302-2552
richard.lydon@sick.com

Paul McElhinney

Sick, Inc.
800 Technology Center Drive
Suite 6
Stoughton, MA 02072
(781) 302-2503
paul.mcelhinney@sick.com

Adam Oldham

Gilbarco, Inc.
7300 West Friendly Ave
Greensboro, NC 27420
(336) 547-5952
adam.oldham@gilbarco.com

Ed Payne

Maryland Department of Agriculture
50 Harry S. Truman Parkway
Annapolis, MD 21401
(410) 841-5790
payneea@mda.state.md.us

Jim Pettinato

FMC Technologies Measurement Solutions, Inc.
1602 Wagner Avenue
Erie, PA 16510
(814) 898-5250
jim.pettinato@fmcti.com

John Roach

California Division of Measurement Standards
6790 Florin Perkins Road
Suite 100
Sacramento, CA 95828
(916) 229-3456
john.roach@cdfa.ca.gov

Ambler Thompson

NIST, Office of Weights and Measures
100 Bureau Drive
Mail Stop 2600
Gaithersburg, MD 20899
(301) 975-2333
ambler@nist.gov

Jim Truex

National Conference on Weights and Measures
88 Carryback Drive
Pataskala, OH43062
(740) 919-4350
jim.truex@ncwm.net

John Wind

Bizerba USA, Inc.
5200 Anthony Road
Sandston, VA 23150
(804) 222-3922
john.wind@bizerba.com

THIS PAGE INTENTIONALLY LEFT BLANK

Appendix F

National Type Evaluation Technical Committee (NTETC) Weighing Sector Meeting Summary

August 28-29, 2012
Annapolis, Maryland

INTRODUCTION

The charge of the NTETC Weighing Sector is important in providing appropriate type evaluation criteria based on specifications, tolerances and technical requirements of NIST Handbook 44, *Specifications, Tolerances, and Other Technical Requirements for Weighing and Measuring Devices*, Sections 1.10. General Code, 2.20. Scales, 2.22. Automatic Bulk Weighing Systems, and 2.24. Automatic Weighing Systems. The Sector’s recommendations will be presented to the National Type Evaluation Program (NTEP) Committee each January for approval and inclusion in NCWM Publication 14, *Technical Policy, Checklists, and Test Procedures* for national type evaluation.

The Sector is also called upon occasionally for technical expertise in addressing difficult NIST Handbook 44, *Specifications, Tolerances, and Other Technical Issues* on the agenda of National Conference on Weights and Measures (NCWM) Specifications and Tolerances (S&T) Committee. Sector membership includes industry, NTEP laboratory representatives, technical advisors, and the NTEP Administrator. Meetings are held annually, or as needed and are open to all NCWM members and other registered parties.

Suggested revisions are shown in **bold face print** by ~~striking-out~~ information to be deleted and underlining information to be added. Requirements that are proposed to be nonretroactive are printed in *bold faced italics*.

Note: It is the policy of the National Institute of Standards and Technology (NIST) to use metric units of measurement in all of its publications; however, recommendations received by NCWM technical committees and regional weights and measures associations have been printed in this publication as submitted. Therefore, the report may contain references in inch-pound units.

Table A Table of Contents

Title of Contents	NTEP Appendix F – Page
INTRODUCTION	1
CARRY-OVER ITEMS	3
1. Recommended Changes to NCWM Publication 14	3
1.a. Item 320-4 UR.1.2. Grain Hopper Scales, Table T.1.1. Tolerance for Unmarked Scales, and Table 7.a. Typical Class of Device for Weighing Applications	3
1.b. Item 320-3. N.3.1.2. Interim Approval	3
1.c. Item 320-6 Appendix D - Definitions (Reference Weight Car)	3
2. Digital Electronic Scale (DES) Section 42. Zero-Load and Tare Adjustment – Monorail Scales Rounding of Intermediate Values in an Equation	4
3. Acceptable Symbols/Abbreviations to Display the CC Number Via a Device’s User Interface	6
4. DES Section 70. – Performance and Permanence Tests for Railway Track Scales Used to Weigh In- Motion	10
5. DES Appendix C- Acceptable Abbreviations for Short Ton and Long Ton	10
6. Sealing/Capabilities of Smart Junction Boxes	13

NEW ITEMS..... 15

7. NCWM Publication 14 Load Cell Table 6 – Summary Table Examples 15

8. NCWM Publication 14, NTEP Administrative Policy 17

9. Next Sector Meeting 17

APPENDIX A – ATTENDEES..... 18

ATTACHMENTS..... 20

Attachment to agenda Item-6: Sealing/Capabilities of Smart Junction Boxes..... 20

Table B
Glossary of Acronyms and Terms

Acronym	Term	Acronym	Term
CC	Certificate of Conformance	NTEP	National Type Evaluation Program
DES	Digital Electronic Scales	NTETC	National Type Evaluation Technical Committee
GIPSA	Grain Inspection, Packers and Stockyards Administration	OIML	International Organization of Legal Metrology
LMD	Liquid Measuring Device	OWM	Office of Weights and Measures
MRA	Mutual Recognition Agreement	R	Recommendation
NCWM	National Conference on Weights and Measures	S&T	Specifications and Tolerances Committee
MC	Measurement Canada	SMA	Scale Manufacturers Association
NEWMA	Northeastern Weights and Measures Association	WS	National Type Evaluation Technical Committee Weighing Sector

Details of All Items
(In order by Reference Key)

CARRY-OVER ITEMS

1. Recommended Changes to NCWM Publication 14

Source:

Mr. Harshman, National Institute of Standards and Technology (NIST), Technical Advisor provided the Sector with specific recommendations for incorporating test procedures and checklist language based upon actions of the 2012 NCWM Annual Meeting. The Sector was asked to briefly discuss each item and, if appropriate, provide general input on the technical aspects of the issues.

1.a. Item 320-4 UR.1.2. Grain Hopper Scales, Table T.1.1. Tolerance for Unmarked Scales, and Table 7.a. Typical Class of Device for Weighing Applications

Source:

2012 S&T Committee Final Report

Background/Discussion:

See the Final Report of the 2012 NCWM S&T Committee Agenda Item 320-4 for the adopted language and additional background information on the item to amend NIST Handbook 44, Scales Code paragraph UR.1.2. Grain Hopper Scales, Table T.1.1. Tolerances for Unmarked Scales, and Table 7a. Typical Class or Type of Device for Weighing Applications to clarify the applicable tolerances for hopper scales used to weigh grain (both unmarked and marked as Class III).

Conclusion:

The WS agreed with the NIST Technical Advisor recommendation that no changes to NCWM Publication 14 are needed.

1.b. Item 320-3. N.3.1.2. Interim Approval

Source:

2012 S&T Committee Final Report

Background/Discussion:

See the Final Report of the 2012 NCWM S&T Committee Agenda Item 320-3 for the adopted language and additional background information on the item to amend NIST Handbook 44 Scales Code paragraph N.3.1.2. Interim and complete additional editorial title changes to paragraphs N.3.1. and N.3.1.1. to clarify the type of tests conducted for an interim approval and to specify how quickly officials are to be notified when scales are repaired and placed in temporary service with an interim test.

Conclusion:

The WS agreed with the NIST Technical Advisor recommendation that no changes to NCWM Publication 14 are needed.

1.c. Item 320-6 Appendix D – Definitions (Reference Weight Car)

Source:

2012 S&T Committee Final Report

Background/Discussion:

See the Final Report of the 2012 NCWM S&T Committee Agenda Item 320-6 for the adopted language and additional background information on the item to amend the definition of “reference weight car” in Appendix D of NIST Handbook 44.

Conclusion:

The WS agreed with the NIST Technical Advisor recommendation that no changes to NCWM Publication 14 are needed.

2. Digital Electronic Scale (DES) Section 42. Zero-Load and Tare Adjustment – Monorail Scales Rounding of Intermediate Values in an Equation

Source:

Mr. Steven Cook, Retired NIST Technical Advisor, OWM (2011 NTETC Weighing Sector, Agenda Item 2)

Background/Discussion:

NCWM Publication 14 DES Section 42 Zero-Load and Tare Adjustment – Monorail Scales currently reflects language in NIST Handbook 44 regarding the setting of zero and tare values that are less than 5 % of the scale capacity to within 0.02 % of scale capacity according to NIST Handbook 44 Scales Code paragraphs S.2.1.4. Monorail Scales and S.2.3.1. Monorail Scales Equipped with Digital Indications. For example, a 1000 lb × 1 lb monorail scale shall have the capability to set tare values up to 50 lb to within a resolution of 0.2 lb (1000 × 0.02 %).

At the 2010 NTETC Weighing Sector Meeting, the Sector agreed to recommend that NCWM Publication 14 Section 42 be amended to clarify rounding of values by adding a new Section 42.3. stating that “rounding is not performed until the last mathematical operation to reduce the uncertainty of the net weight calculation.”

The Sector also discussed the potential differences and verification of rounding when net weights are determined using a digital indicator's internal or displayed resolution of the gross weight.

At the 2011 NTETC Weighing Sector Meeting, the Sector agreed that test criteria needs to be developed to verify whether or not scales submitted for type evaluation comply with the tare requirements in NIST Handbook 44 Scales Code paragraph S.2.3.1. A few members of the Sector agreed to work on developing possible test criteria that could be added to NCWM Publication 14 to verify whether a device submitted for type evaluation complies. It was also agreed that the work group would seek input from Mr. Ainsworth, U.S. Department of Agriculture (USDA)/Grain Inspection Packers and Stockyard Administration (GIPSA), and Mr. Vande Berg, Vande Berg Scales, when developing the test criteria.

Following the 2011 NTETC Weighing Sector Meeting, Mr. Cook, NIST, OWM, contacted Mr. Vande Berg for his input on the proposed development of procedures to determine if net weights are determined using the digital indicator's internal or displayed resolution of the gross weight in the calculation of the net weight and verify that tare weights that are smaller than the verification scale division “e” are not rounded to the value of “e” when calculating net weights for both static and dynamic monorail scales. It should also be noted that NIST Handbook 44 Scales code paragraph S.1.2.2.1. Class I and II Scales and Dynamic Monorail Scales allows Class III and unmarked dynamic monorail scales to have a “d” value less than “e” unlike other Class III and unmarked scales.

Mr. Vande Berg stated that he was concerned that the language recommended by the Sector in 2010 will cause a much more confusing issue with inspectors and packers. He was unaware of any packer that currently sends gross weights in 1 lb divisions and applies a 0.1 lb tare anymore. This confusion in 1997 or so was dealt with by the State of Nebraska and Packers and Stockyards (Mr. Onwiler and Mr. Blachford in attendance) before the provision allowing different values of “e” and “d” was added to NIST Handbook 44 in 1999.

Mr. Vande Berg added that there has been little to no confusion, and he believes that this issue had been previously addressed and does not currently exist in the major packers since the adoption of paragraph S.1.2.2.1. The value of “e” in dynamic monorails is basically always 1.0 lb. There is some confusion about the value of “d” in dynamic

monorails. Most states allow, and Packers and Stockyards encourages (in Mr. Vande Berg's opinion a good thing), scales to display in 0.1 lb divisions regardless of the scale division value listed on the NTEP Certificate of Conformance (CCs) since the producer (cattle seller) is virtually never in attendance at the time of the transaction (which takes place in the packing plant so no transaction confusion due to the difference between "d" and "e" exists). This allows both the Packers and Stockyards inspector and the service agent the ability to more accurately gauge the performance of the dynamic scale during static and dynamic testing that is also recorded in 0.1 lb divisions. States like Illinois require scales comply with the value of "d" specified on the CC, which in Vande Berg Scale's case is 0.2 lb, thus hurting both the packers maintenance people and the Packers and Stockyards inspection.

Mr. Vande Berg believes that accurately arriving at two net weight "d" values first, and then summing the net weights (by adding them together), makes more sense and is more in line with how MOST packers operate. Taking tare after adding gross weight values for cattle monorails (especially) will cause considerable trouble and in his opinion not a good way to handle the potential rounding error problem that he doesn't believe exists significantly in the field anymore. Field problems with subtraction and rounding may stem from weight indication manufacturers or unknowing dealers that are simply not accurately calculating net weight values because their equipment may not be capable of S.2.3.1. Monorail Scales Equipped with Digital Indications. (This is often the case as most indicator manufacturers do not understand the monorail tare requirement.) Vande Berg Scales generally insist that the tare is subtracted inside the indicator because of those potential rounding error issues.

Mr. Vande Berg recommended that the Sector review the language that was added to NCWM Publication 14 DES Section 42.3 to clarify that in the case of cattle, where the net weights of two half-carasses are added together, the net weights of the individual weighments remain in the "d" values and that the summed weight will then be rounded to the value of "e". To avoid controversy on this topic, he recommended the language in Section 42.3 be replaced with a statement such as "tare weight subtraction must always be done with weight values that are equal in division size to "d" or less of the scale."

Technical Advisors Note: In the case of dynamic monorail scales, $d < e \leq 10 d$, as specified in Scales code paragraph S.1.2.2.1. Class I and II Scales and Dynamic Monorail Scales. In the case of static monorail scales, the value of "e" must be equal to or less than the value of "d," as specified in paragraph S.1.2.2.2. Class III and IIII Scales.

An additional recommendation made by Mr. Vande Berg was to modify the language in the first sentence of Scales code paragraphs S.2.3.1. Monorail Scales Equipped with Digital Indications and S.2.1.4. Monorail Scales by adding the words "at least" to the first sentence of each paragraph so that the ending portion of those sentences would read as follows:

"means shall be provided for setting the zero-load balance to within at least 0.02 % of scale capacity."

The Sector may wish to consider Mr. Vande Berg's additional recommendation as changing the language of these two NIST Handbook 44 paragraphs may impact the application of NCWM Publication 14 DES Section 42.1.

Since there have been few rounding problems discovered by Packers and Stockyards since the issue was raised in 2010, the Sector may want to discuss the need for developing additional procedures to determine if net weights are determined using the digital indicator's internal or displayed resolution of the gross weight in the calculation of the net weight, and verify that tare weights that are smaller than the verification scale division "e" are not rounded to the value of "e" when calculating net weights for both static and dynamic monorail scales.

Mr. Vande Berg recommended the following changes to NCWM Publication 14, Section 42:

42. Zero-Load and Tare Adjustment – Monorail Scales

Code References: S.2.1.4. and S.2.3.1.

Under the regulations of the Packers and Stockyards Administration, the rollers and hooks used on monorail scales within a facility are required to be nearly the same weight. Since dynamic monorail scales typically have seale verification (e) divisions of 1 lb, a monorail scale must be capable of setting tare weights that are

less than 5 % of the scale capacity to a weight value less than the displayed scale division. This reduces the rounding error in the tare weight that would otherwise be present if the tare weight were rounded to the nearest displayed scale division.

- 2.1. Means must be provided for setting the zero-load balance and any tare value less than 5 % of the scale capacity to within 0.02 % **or less** of scale capacity. Yes No N/A
- 2.2. For an in-motion system, the conditions above must be automatically maintained. Yes No N/A
- 2.3. Rounding **to the value of (e)** is not performed until the last mathematical operation to reduce the uncertainty of **the summed** net weight calculation. Yes No N/A

For additional background information relative to this item and actions taken by the NTETC Weighing Sector during its 2010 and 2011 meetings go to: ncwm.net/content/weighing-archive

Conclusion:

Mr. Vande Berg, Vande Berg Scales, and Mr. Arce, GIPSA, were present at the 2012 WS meeting to assist in explaining and answering questions relative to this item. They reviewed with members of the WS some of the more typical procedures used by U.S. meat packing companies to determine the weight of animal carcasses obtained from monorail scale systems of varying design. As part of that discussion, they also identified some concerns they had relative to some of the weighing practices and designs of some of the monorail scale systems. Two main concerns were identified and discussed:

1. The additional rounding error caused by weighing two halves of an animal carcass separately on a scale with digital indication, and
2. The taking of tare to an increment different from the displayed scale division.

The WS considered whether any of the current requirements in HB-44 might already address the concerns raised by Mr. Vande Berg and Mr. Arce and concluded that they did not. It was then suggested, and the WS agreed, that NIST Handbook 44 should first be amended, rather than NCWM Publication 14, because the evaluation criteria in NCWM Publication 14 is intended to determine whether or not equipment submitted for type evaluation complies with NIST Handbook 44 requirements. Thus, it would be inappropriate to develop type evaluation criteria to address issues that have no corresponding NIST Handbook 44 requirement. For this reason, the WS agreed to take no action on the item pending possible future changes to NIST Handbook 44. Mr. Vande Berg and Mr. Arce agreed to develop, with the assistance of Mr. Harshman, NIST Technical Advisor, an NCWM Form 15 proposal to amend NIST Handbook 44 and address all concerns.

3. Acceptable Symbols/Abbreviations to Display the CC Number Via a Device’s User Interface

Sources:

- 2009 NTETC Software Sector Agenda Item 3 and 2010 S&T Item 310-3 G-S.1. Identification. (Software)
- 2010 Final Report of the S&T Committee: ncwm.net/content/annual-archive
- 2010 Software Sector summary: ncwm.net/content/software-archive
- 2011 Software Sector summary: ncwm.net/content/software-docs
- 2011 Final Report of the S&T Committee (Publication 16 a nd addendum sheets): ncwm.net/content/annual-archive
- 2012 Software Sector summary: ncwm.net/content/software-docs

Background/Discussion:

Local weights and measures inspectors need a means to determine whether equipment discovered in the field has been evaluated by NTEP. If so, the inspector needs to know at a minimum the CC number. From this starting point, other required information can be ascertained. NIST Handbook 44 currently includes three options for marking of the CC:

1. Permanent marking
2. Continuous display
3. Recall using a special operation

Additional background information relative to this item can be found in 2012 NCWM Publication 16 at: ncwm.net/content/annual-archive

At the 2011 NCWM Annual Meeting, the S&T Committee agreed to change the status of this item to Developing because the item was lacking enough information for full consideration and a full proposal has yet to be developed.

At the 2011 NTETC Weighing Sector Meeting, the Sector agreed to take no additional action on this item pending further development of the item by the NTETC Software Sector.

During the 2012 Software Sector Meeting, Mr. Truex, NTEP Administrator, discussed the difficulty there has been in coming to a consensus on these issues with a representative of the NTEP Committee. Suggestions from NTEP to come to some resolution has been to write an article for the newsletter (which Mr. Bliss, Mettler-Toledo, LLC, had already done, to no effect), sending a questionnaire to the NTEP community, asking what they'd like to see, and sending a representative from this Sector to the S&T Committee.

Mr. Roach, California Division of Measurement Standards, was concerned that some people may want to interpret G-S.1.(c) as requiring a serial number for software. Mr. Lewis, Rice Lake Weighing Systems, Inc. pointed out that the computer that the software was running on could have the serial number, not the software itself. That shouldn't matter, regardless.

Mr. Bliss, Mettler-Toledo, LLC, pointed out that the terminology in G-S.1., "All equipment" could be interpreted to mean that it doesn't apply to software. It was proposed that G-S.1.(c) be amended to add "and software." Mr. Bliss suggested submitting a document explaining the reasoning behind the proposed changes, rather than assume that the text is self-explanatory. Making a presentation to the various Committees on the subject in addition would be beneficial as well. If a document is written, perhaps the examples given in G-S.1.(d)(3)(a) can be eliminated. "Metrologically significant" isn't explicitly defined, but it's been used since time immemorial.

Attempts to modify G-S.1.1. have been controversial, both in this meeting and in other committees. Unfortunately, there has been little constructive feedback from the other committees. It would probably be easier to incorporate specific examples given in G-S.1.1.(b)(3) in NCWM Publication 14. After some discussion, the previously proposed language was modified slightly to address some of the concerns received via feedback from other Sectors and interested parties:

NIST Handbook 44 – Software Sector Proposed modifications to 2012 NCWM Publication 16 Developing Item 360-2 G-S.1. Identification. (Software) Proposed modifications are described below and shown in shaded text):

The Software Sector modified the Developing item by deleting the proposed additional language in the first sentence in paragraph G-S.1. to read as follows:

G-S.1. Identification. – All equipment, except weights and separate parts necessary to the measurement process but not having any metrological effect, ~~and software-based devices covered in G-S.1.1. Location of Marking Information*~~, shall be clearly and permanently marked for the purposes of identification with the following information:

(a) the name, initials, or trademark of the manufacturer or distributor;

(b) a model identifier that positively identifies the pattern or design of the device;

(1) *The model identifier shall be prefaced by the word "Model," "Type," or "Pattern." These terms may be followed by the word "Number" or an abbreviation of that word. The abbreviation for the word "Number" shall, as a minimum, begin with the letter "N" (e.g., No or No.). The abbreviation for the word "Model" shall be "Mod" or "Mod." Prefix lettering may be initial capitals, all capitals, or all lowercase.*

[Nonretroactive as of January 1, 2003]

(Added 2000) (Amended 2001)

The Software Sector modified the Developing item by replacing the proposed reference to “software-based electronic devices” with the single word “software” to read as follows:

- (c) ~~a nonrepetitive serial number, except for equipment with no moving or electronic component parts and not built for purpose software-based electronic devices~~ **software.**
[Nonretroactive as of January 1, 1968]
(Amended 2003)
- (1) *The serial number shall be prefaced by words, an abbreviation, or a symbol, that clearly identifies the number as the required serial number.*
[Nonretroactive as of January 1, 1986]
- (2) *Abbreviations for the word “Serial” shall, as a minimum, begin with the letter “S,” and abbreviations for the word “Number” shall, as a minimum, begin with the letter “N” (e.g., S/N, SN, Ser. No., and S. No.).*
[Nonretroactive as of January 1, 2001]

The Software Sector modified the Developing item by deleting the proposed reference to “software-based electronic devices” to read as follows:

- (d) ~~the current software version or revision identifier for not built for purpose software-based electronic devices.~~
[Nonretroactive as of January 1, 2004]
(Added 2003) **(Amended 20XX)**
- (1) *The version or revision identifier shall be prefaced by words, an abbreviation, or a symbol, that clearly identifies the number as the required version or revision.*
[Nonretroactive as of January 1, 2007]
(Added 2006)
- (2) *Abbreviations for the word “Version” shall, as a minimum, begin with the letter “V” and may be followed by the word “Number.” Abbreviations for the word “Revision” shall, as a minimum, begin with the letter “R” and may be followed by the word “Number.” The abbreviation for the word “Number” shall, as a minimum, begin with the letter “N” (e.g., No or No.).*
[Nonretroactive as of January 1, 2007]
(Added 2006)

The Software Sector modified the Developing item by adding a new subparagraph G-S.1. (d) (3) to read as follows:

- (3) ***The version or revision identifier shall be accessible via the display. Instructions for displaying the version or revision identifier shall be described in the CC. As an exception, permanently marking the version or revision identifier shall be acceptable under the following conditions:***
- (a) ***The user interface does not have any control capability to activate the indication of the version or revision identifier on the display, or the display does not technically allow the version or revision identifier to be shown (analog indicating device or electromechanical counter) or***
- (b) ***the device does not have an interface to communicate the version or revision identifier.***
- (e) **an NTEP CC number or a corresponding CC Addendum Number for devices that have a CC.**
- (1) *The CC Number or a corresponding CC Addendum Number shall be prefaced by the terms “NTEP CC,” “CC,” or “Approval.” These terms may be followed by the word “Number” or an abbreviation of that word. The abbreviation for the word “Number” shall, as a minimum, begin with the letter “N” (e.g., No or No.).*
[Nonretroactive as of January 1, 2003]

The required information shall be so located that it is readily observable without the necessity of the disassembly of a part requiring the use of any means separate from the device.

(Amended 1985, 1991, 1999, 2000, 2001, 2003, ~~and~~, 2006 **and 201X**)

G-S.1.1. Location of Marking Information for ~~Not-Built-For-Purpose~~ all Software-Based Devices. --For ~~not-built-for-purpose~~, software-based devices, either:

The Software Sector modified the Developing item by reinstating references to subparagraphs “G-S.1. Identification (a),

(b), and (e)” in paragraph G-S.1.1. (a) to read as follows:

(a) The required information in G-S.1. Identification. (a), (b), ~~(d)~~, and (e) ~~(a)~~, ~~(b)~~, ~~(d)~~, and ~~(e)~~ shall be permanently marked or continuously displayed on the device; or

(b) The CC Number shall be:

(1) permanently marked on the device;

(2) continuously displayed; or

(3) accessible through ~~an easily recognized menu and, if necessary, a submenu. Examples of menu and submenu identification include, but are not limited to, “Help,” “System Identification,” “G-S.1. Identification,” or “Weights and Measures Identification.”~~ one or, at most, two levels of access.

(i) For menu based systems, “Metrology,” System Identification,” of “Help.”

(ii) For Systems using icons, a metrology symbol “(M),” (SI),” or a help symbol (“?”, “I,” or and “I” within a magnifying glass).

Note: For (b), clear instructions for accessing the information required in G-S.1. (a), (b), and (d) shall be listed on the CC, including information necessary to identify that the software in the device is the same type that was evaluated.

[Nonretroactive as of January 1, 2004]

(Added 2003) (Amended 2006 and 20XX)

The new language in G-S.1.1. reflects that the Sector reached consensus on the following positions:

- The software version/revision should (with very few exceptions – see D-31 5.1.1) be accessible via the user interface.**
- The means by which the software version is accessed must be described in the Certificate of Conformance (CC).**

In addition, it was asserted that the previously recommended changes to G-S.1.1.(b)(3) in fact are not really necessary; the current language of NIST Handbook 44 empowers the laboratories to enforce “easily recognizable” as they see fit. In fact, the previously generated “list” of icons and menu options could certainly be used by the examining laboratories as part of the approval process (e.g., in NCWM Publication 14). Of course, a manufacturer who is reviewing NIST Handbook 44 so as to develop an acceptable device may benefit from more explicit guidance. Where does such guidance belong?

Comments related to the circulated list included a comment from the Scale Manufacturers Association (SMA) suggesting that a definition is needed for “software-based devices.” SMA opposed the definitions previously put forth by the Sector. It was suggested that perhaps SMA would be more amenable to a definition that doesn’t differentiate between software types.

Since this item is currently defined as a Developing Item, it cannot be moved to a Voting Item at the 2012 NCWM Annual Meeting; it will have to wait until 2013. In January of 2013, the item will be reviewed and a decision will be made whether or not to change the status of this item. To upgrade the status of this item, the Sector will need to explain the intent behind the proposed changes to G-S.1. and G-S.1.1.

Conclusion:

It was reported that the Software Sector is still actively working on this item and that during the SMA meetings in April 2012 a member of that Sector was present and had circulated that Sector’s proposed modifications to members of the SMA for input. The general view of most members of the SMA was favorable towards the proposed changes. Members of the WS were then offered the opportunity to provide an opinion on the modifications proposed, but no one opted to do so. The WS agreed to take no additional action on this item pending further development of the item by the Software Sector.

4. DES Section 70. – Performance and Permanence Tests for Railway Track Scales Used to Weigh In-Motion

Source:

Mr. Luthy, Stock Equipment Company, Inc. (2011 NTETC Weighing Sector Agenda Item 6)

Background/Discussion:

During the 2011 NTETC Weighing Sector Meeting, the Sector discussed a weigh in-motion system using new technology that utilizes continuous rails (no “rail gaps”) on the approaches and weighing areas of the scale. The submitter stated that the manufacturer was unable to offer this device for sale in the United States in commercial applications because current NTEP type evaluation criteria and NIST Handbook 44 requirements were written in such a way that makes it impossible for devices incorporating this new technology to comply. For example, NIST Handbook 44, Scales Code paragraph UR.2.4. Foundations, Supports, and Clearance requires clearance be provided around all live parts to the extent that no contacts may result. NCWM Publication 14, DES Section 70, Inspect the Scale, Item 4 Rail Gaps states that “the rail gaps should be set at $\frac{3}{8}$ inch.” The *AAR Scale Handbook* includes language that allows $\frac{1}{8}$ inch to $\frac{5}{8}$ inch rail gaps.

The members of the Sector agreed that they were not willing to recommend deleting references to the required gaps in the rail until it is proven that the new technology complies with the tolerances in NIST Handbook 44. Thus, the Sector recommended that the applicant move forward with performance testing to confirm that the new technology complies with the tolerances in NIST Handbook 44. The Sector agreed that data resulting from the performance testing needed to be submitted to the Sector prior to the time that the 2012 NTETC Weighing Sector Agenda was developed or the item should not be included as a carryover item on that agenda.

For additional background information relative to this item and actions taken by the NTETC Weighing Sector during its 2011 meeting go to: ncwm.net/content/weighing-archive

Conclusion:

Mr. Luthy, Stock Equipment Co., provided a brief update on the progress of the performance testing to date. He reported that ongoing testing is still being conducted at the Association of American Railroads (AAR) Transportation Technology Center near Pueblo, Colorado. Because the testing is still ongoing, the WS agreed to Mr. Luthy’s request to maintain the item as a Carryover item on the 2013 NTETC Weighing Sector Agenda providing a report resulting from the testing is submitted to the Sector prior to the time that the 2013 NTETC Weighing Sector Agenda is developed. Otherwise, the item should not be included as a Carryover item on the 2013 WS Agenda.

5. DES Appendix C- Acceptable Abbreviations for Short Ton and Long Ton

Source:

Mr. Lewis, Rice Lake Weighing Systems, Inc. (2011 NTETC Weighing Sector Agenda Item 8)

Background/Discussion:

At the 2011 NTETC Weighing Sector Meeting, Mr. Lewis, Rice Lake Weighing Systems, Inc., recommended adding “tn” as an acceptable abbreviation for a U.S. short ton to the current list of acceptable abbreviation of “Ton” or “TN.” Mr. Lewis is also recommended that “lt” be added to the list of acceptable abbreviations for a long ton. He added that the *Canadian Lab Manual*, Part 2, Section Appendix-2A in the table for abbreviations and symbols accepted in Canada, metric ton is abbreviated by “t” and ton (short ton) is abbreviated by “tn.”

The Sector agreed to add “tn” to the table of Acceptable Abbreviations in Appendix C of NCWM Publication 14 as an acceptable abbreviation for short ton. Mr. Harshman, NIST Technical Advisor, noted that the abbreviation “tn” does not exist in Appendix C of NIST Handbook 44 nor in NIST SP 811, *Guide for the Use of the International System of Units (SI)*, and this change recommended by the Sector, if approved, would add the abbreviation to only one portion of NCWM Publication 14 table, that is, to the portion titled “Exceptions to General Tables” of NIST Handbook 44. The Sector also agreed to delay taking any action on adding the abbreviation “lt” for long ton until

the S&T Committee has had an opportunity to consider the proposal from Mr. Lewis, Rice Lake Weighing Systems, Inc., to amend NIST Handbook 44 by adding the abbreviations “tn” for short ton and “lt” for long ton.

At the 2012 NCWM Interim Meeting, the original submitter, Mr. Lewis, Rice Lake Weighing Systems, Inc., requested that the proposal in the Interim Agenda be modified to remove the reference to long ton and its associated proposed abbreviation “lt.” Mr. Lewis indicated that the intent of the proposal is to align United States and Canadian requirements and noted that the abbreviation “tn” is an acceptable Canadian abbreviation for short ton.

Mr. Flocken, speaking on behalf of the SMA, suggested making the item Informational to allow for more discussion. He stated that SMA supports the abbreviation “tn” for short ton but not the long ton abbreviation “lt.”

Mr. Ripka, Thermo Fisher Scientific, indicated that several different references for ton (short) have been used with belt-conveyor scale systems over the years. For example, both lower case “t” and upper case “T” have been used to abbreviate short ton. He stated that although he was not opposed to the item, more work is needed to ensure that references are consistent throughout all of NIST Handbook 44.

The S&T Committee considered the comments received during the Open Hearings and agreed with the recommendation to amend the Units of Mass table on page C-19 of NIST Handbook 44, Appendix C as shown in Item Under Consideration. The Committee agreed that additional work was needed on this item. The Committee asked the NIST Technical Advisors to undertake a review of the references in NIST Handbook 44, the Canadian requirements, and NCWM Publication 14, and identify any additional changes that might be needed to ensure consistency. Additionally, the Committee is seeking input from the community on the impact that this item might have on existing scales in the marketplace. The 2012 S&T Committee designated this item as an Informational Item.

After the 2012 NCWM Interim Meeting had concluded, NIST, OWM, in reviewing summary comments from the 2011 SWMA fall meeting, discovered an additional reference on page C-6 of Appendix C, NIST Handbook 44 that SWMA had identified as needing to be changed in order to be consistent with the change proposed in the Item Under Consideration. NIST, OWM suggested that the Committee consider the following changes for future consideration of this item:

Amend the abbreviation “t” representing the “net” or “short” ton on page C-6 of NIST Handbook 44 Appendix C to “tn” as follows:

Avoirdupois Units of Mass⁶

[The “grain” is the same in avoirdupois, troy, and apothecaries units of mass.]

1 μ lb	= 0.000 001 pound (lb)
27 ^{11/32} grains (gr)	= 1 dram (dr)
16 drams	= 1 ounce (oz)
	= 437½ grains
16 ounces	= 1 pound (lb)
	= 256 drams
	= 7000 grains
100 pounds	= 1 hundredweight (cwt) ⁷
20 hundredweights	= 1 ton (tn)
	= 2000 pounds ⁷

In “gross” or “long” measure, the following values are recognized:

112 pounds (lb)	= 1 gross or long hundredweight (cwt) ⁷
20 gross or long hundredweights	= 1 gross or long ton
	= 2240 pounds

NTEP Committee 2013 Final Report
Appendix F –NTETC 2012 Weighing Sector Meeting Summary

⁶ When necessary to distinguish the **avoirdupois** dram from the **apothecaries** dram, or to distinguish the **avoirdupois** dram or ounce from the **fluid** dram or ounce, or to distinguish the avoirdupois ounce or pound from the **troy** or **apothecaries** ounce or pound, the word “avoirdupois” or the abbreviation “avdp” should be used in combination with the name or abbreviation of the **avoirdupois** unit.

⁷ When the terms “hundredweight” and “ton” are used unmodified, they are commonly understood to mean the 100 pound hundredweight and the 2000-pound ton, respectively; these units may be designated “net” or “short” when necessary to distinguish them from the corresponding units in **gross** or **long** measure.

Additional letters, presentations, and data may have been part of the Committee’s consideration. Please refer to www.ncwm.net/content/2012pub-16 to review these documents.

At the 2012 NCWM Annual Meeting, the Committee acknowledged that the reference to “lt” is no longer under consideration. Mr. Darrell Flocken, speaking on behalf of SMA, reiterated the comments he made at the Central Weights and Measures Association (CWMA) meeting and supported changing the item to Informational.

NIST, OWM noted that the 2011 NCWM Publication 14 Belt-Conveyor Scale Systems type evaluation criteria provides a table on page BCS-4 that indicates the U.S. short ton may be identified as “ton” or upper case “T;” the metric ton as lower case “t;” and the U.S. long ton as upper case “LT.” The following abbreviations appear in the 2011 version of NCWM Publication 14 BCS systems type evaluation criteria:

Unit	Abbreviation
pounds	lb or LB
U.S. short ton	ton or T
U.S. long ton	LT
Metric ton	t
kilograms	kg

The abbreviation “T” for U.S. short ton in NCWM Publication 14 conflicts with the acceptable abbreviation for the U.S. short ton specified in Appendix C of NIST Handbook 44, which is “t.” A search of the word “ton” in Appendix C of NIST Handbook 44 revealed that nowhere is upper case “T” used, although lower case “t” appears as an acceptable abbreviation for both the U.S. short (or net) ton (page C-6) and the metric ton (page C-19). NIST, OWM is concerned that officials applying paragraph G-S.5.6.1. might be inclined to reject an upper case “T” as an acceptable abbreviation for the U.S. short (or net) ton even though NCWM Publication 14 indicates that the upper case “T” is acceptable. Officials might also find it confusing if lower case “tn” were made an acceptable abbreviation for the U.S. short or net ton, given that the table on page BCS-4 of NCWM Publication 14 specifies lower case “t” as the acceptable abbreviation for the metric ton.

NIST, OWM noted that even if everyone were to agree on different acceptable abbreviations for the U.S. short or net ton, the U.S. long ton, and the metric ton, it is not likely that this would completely resolve all the confusion relating to the value of the ton in commercial transactions. The spelled-out version of the word “ton” is often used instead of its abbreviation to identify values displayed or recorded by a commercial device. Thus, unless the word “ton” is further qualified using an appropriate clarifying preface such as metric, short, net, or long, it’s unclear as to which ton is being referenced when the word “ton” by itself is used to identify the unit of measure.

NIST, OWM suggested that the Committee consider changing the abbreviation “t” (which refers to 1 ton (short), beneath the heading “Avoirdupois Units of Mass” on page C-6 of the 2012 version of NIST Handbook 44) to “tn” to avoid conflict with the recommended proposal. NIST, OWM also noted that the abbreviation “lt” was erroneously left in the table.

The Committee agreed that the “lt” abbreviation for “1 ton, gross or long” in the table on page S&T 20 of 2012 NCWM Publication 16 was erroneously left in the table from the original proposal and should be removed.

The Committee reiterated its request for input from the community on the impact that this item might have on existing scales in the marketplace and asks for input regarding what additional changes might be needed to the proposal prior to moving it forward.

The Committee recommended deleting the reference to “Long Ton” in the “Purpose” so that it reads as follows:

“Purpose: Establish uniform abbreviations for Short Ton.”

The Committee also recommended deleting the reference to “It” in the “Units of Mass” table in the “Item Under Consideration” so that the reference for “1 ton, gross” reads as follows:

1 ton, gross or long¹⁹

Background information may be obtained online at:

2011 NTETC WS

Summary: ncwm.net/sites/default/files/meetings/weighing/2011/2011_Weighing_Meeting_Summary.pdf

2012 S&T Interim

Report: www.ncwm.net/sites/default/files/meetings/annual/2012/S%26T%20docs/2012_Pub16_ST.pdf

2012 S&T Final Report:

www.nist.gov/pml/wmd/pubs/sp1160

Conclusion:

Mr. Harshman, NIST Technical Advisor, reviewed background associated with this item and reported that prior to the 2012 NCWM Annual Meeting, Mr. Ripka, Thermo Ramsey had expressed a concern that field officials might find it confusing if lower case “tn” were adopted as an acceptable abbreviation for short or net ton because the abbreviation “t” is considered an acceptable abbreviation for metric ton in NCWM Publication 14 BCS. He also pointed out that even if the abbreviation “tn” was adopted, this would not clear up all the confusion surrounding the value of the ton in commercial transactions. In cases where the word ton is spelled out and no abbreviation is used, additional qualifying words are needed to identify which ton is being referenced. Mr. Lewis, Rice Lake Weighing Systems, Inc., commented that the proposal was intended to harmonize U.S. and Canadian requirements, noting that Canada accepts “tn” as an acceptable abbreviation for short ton. Mr. Flocken, Mettler-Toledo, Inc., added that the change would make it easier for scale manufacturers if they could manufacture scales using a single acceptable abbreviation. Mr. Luciano Burtini, MC, stated that upper case “T” is not permitted as an acceptable abbreviation for short or net ton as it is in NCWM Publication 14 BCS. The lower case “tn” is the acceptable Canadian abbreviation for short ton and lower case “t” is the acceptable abbreviation for metric ton. Mr. Harshman, NIST Technical Advisor, will forward the Sector’s comments and recommendations to the appropriate regional and NCWM Committees for their consideration and comments.

6. Sealing/Capabilities of Smart Junction Boxes

Source:

Mr. Payne, Maryland Department of Agriculture (2011 NTETC Weighing Sector Agenda Item 11)

Background / Discussion:

At the 2011 NTETC Weighing Sector Meeting, Mr. Payne, Maryland Department of Agriculture, requested the Sector’s guidance on the proper means of sealing, and assistance in determining the capabilities of a “smart junction box,”(aka “smart “J” box”) which was about to be submitted to the Maryland Laboratory for NTEP certification. Although not confirmed, it was Mr. Payne’s belief (based on discussions with an equipment manufacturer) that the “smart junction box” provided a means of remotely accessing calibration and/or configuration adjustments once installed in a scale.

Mr. Truex, NTEP Administrator, pointed out that such adjustments can generally only be carried out through the indicator of a weighing system comprised of separable components (i.e., an indicator, weighing/load-receiving element, and load cells). NTEP evaluates each of these components separately, issuing a separate CC for each

component once that component has passed type evaluation criteria. Notations made on the CC by the evaluator typically provide an indication of the compatibility and/or non-compatibility of a component with other separable components.

During the discussion, it was mentioned that several U.S. scale manufacturers, including some who were represented in the room, design and manufacture smart “J” boxes. Mr. Flocken, Mettler-Toledo, LLC, noted that internationally, as many as seven different components of a scale are type evaluated using test criteria contained in International Organization of Legal Metrology (OIML) Recommendations. He questioned whether the Sector might want to further research the capabilities of “smart “J” boxes” and possibly consider developing type evaluation criteria to evaluate them as separate component of a weighing system.

The Sector agreed to form a small work group to study the capabilities of this equipment and determine whether or not type evaluation criteria should be developed to evaluate them as a separate component. Mr. Harshman, NIST, OWM agreed to organize the first teleconference to review the requirements for a Smart Junction Box. Additionally, the Sector agreed that, the term “smart junction box” refers to a device that contains active components and used to digitize the output of one or more analog load cells. The box may include a processing component with or without software to scale or calibrate the digitized output. The box transmits the weight information to an indicating element either via a wireless or wired connection.

During the discussion of the November 3, 2011, teleconference, there was general agreement that, because the junction box contained active elements, it should be tested for environmental influence factors as described in NIST Handbook 44 Scales Code paragraph T.N.8. It was also determined that there are two basic types of smart junction boxes; those that only digitize the load cell signal(s) and those that digitize and then calibrate the load cell signal(s).

It was concluded that checklist procedures and language will be developed to describe the evaluation of this device type and that this would be submitted to the NTETC Weighing Sector at their next regularly scheduled meeting. To accomplish this, a workgroup would be formed. The workgroup would be made up of device manufacturers, representatives of NIST, OWM and NTEP, and lab personnel. Mr. Langford, Cardinal Scale Manufacturing Co., volunteered to serve as the *ad hoc* chair of the workgroup and indicated the first step would be to develop a list of the devices of this type already assigned NTEP CCs. Mr. Harshman, NIST, OWM provided the contact information for the participants at the teleconference.

The draft procedures and discussions were developed, reviewed, and agreed upon by the work group by the end of December 2011 and submitted to Mr. Truex, NTEP Administrator, and Mr. Harshman, NIST, OWM for discussion at the 2012 NTETC Weighing Sector Meeting.

For additional background information relative to this item and actions taken by the NTETC Weighing Sector during its 2011 meeting go to: ncwm.net/content/weighing-archive

Conclusion:

Members of the Sector, including the NTEP evaluators who were present at the meeting, voiced support to adding the draft evaluation criteria to NCWM Publication 14. During the discussion, it was noted that the draft document was developed and borrowed heavily from criteria already existing in NCWM Publication 14. The Sector agreed that the draft type evaluation criteria should be recommended for addition to the DES portion of NCWM Publication 14 as a new Section 76 and that its title should be “Digital Controller Element for Load Cells.” This new section should also be referenced in the DES Table of Contents beneath the heading titled: “Checklists and Test Procedures,” as a new Section 76. The draft evaluation criteria recommended for insertion into NCWM Publication 14 can be found in the Attachment section of this summary and is titled: Attachment to agenda Item-6: Sealing/Capabilities of Smart Junction Boxes.

NEW ITEMS

7. NCWM Publication 14 Load Cell Table 6 – Summary Table Examples

Source:

NTEP Administrator

Background/Discussion:

The NTEP Administrator was contacted by an individual questioning tolerance values for repeatability and creep shown in the example summary table in NCWM Publication 14 – Load Cells Table 6 “Example of a Summary Table for a Class III 3000 Single Load Cell” (the reported errors are shown in Table 6 in **shaded text**). The individual reported that:

1. The tolerance listed on the table should be the value from Table 3 - Tolerance for Class III Load Cells, page LC-10. That is, the repeatability error of a Class III 3000 single cell requirement (from Table 3) should be 0.7v (0-500v); 1.4v (501-2000v); 2.1v (2001-4000v); 3.5v (4001-10 000v), so the value of repeatability error shown on Table 6 should be other than 0.35v.
2. Similar error on Creep (time dependence) of Table 6, the value should follow the mpe Table T.N.4.6., the value of creep shown on Table 6 should be 1.05v other than 1.5v.
3. Same error on Creep change ($I_{20min} - I_{30min}$) of Table 6, according to Table T.N.4.6., it should be 0.1575v (0.15 x mpe) other than 0.225v.

Table 6.

Example of a Summary Table for a Class III 3000 Single Load Cell

Summary Table				
(As requested in Item 12 of the load cell data format paper)				
		Critical Result	Tolerance	Result/Tolerance
a.	Load Cell Error	0.68 v	0.7 v	0.97
	Repeatability Error	0.19 v	0.35 v	0.55
	Temperature Effect on MDLO	0.57 v _{min} /5 °C	0.7 v _{min} /5 °C	0.82
	Creep (time dependence)	0.98 v	1.5 v	0.65
	Δ Creep = $I_{20\ min} - I_{30\ min}$	0.09 v	0.15 x mpe = 0.225 v	0.40
	Creep Recovery	0.17 v	0.5 v	0.34
	Effect of Barometric Pressure	0.185 v _{min} /kPa	1.0 v _{min} /kPa	0.15

Table 3.
Tolerance for Class III Load Cells

NIST Handbook 44 Reference	Single Cell Requirement		Multiple Cell Requirement	
Load Cell Error Table 6., Class III; T.N.3.2. and T.N.8.1.1.	0.7 Factor Applied		1.0 Factor Applied	
	Load	Tolerance	Load	Tolerance
	0 – 500v	0.35v	0 – 500v	0.50v
	501 – 2000v	0.70v	501 – 2000v	1.00v
	2001 – 4000v	1.05v	2001 – 4000v	1.50v
	4001 – 10 000v	1.75v	4001 – 10 000v	2.50v
Repeatability Error; T.N.5. and T.N.8.1.1.	0.7 Factor Applied		1.0 Factor Applied	
	Load	Tolerance	Load	Tolerance
	0 – 500v	0.70v	0 – 500v	1.00v
	501 – 2000v	1.40v	501 – 2000v	2.00v
	2001 – 4000v	2.10v	2001 – 4000v	3.00v
	4001 – 10 000v	3.50v	4001 – 10 000v	5.00v
Temperature Effect on Minimum Dead Load Output; T.N.8.1.3. and T.N.8.1.1.	0.7 v _{min} /5 °C		0.7 v _{min} /5 °C	
Effects of Barometric Pressure; T.N.8.2.	Applicable only to specified load cells 1 v _{min} /1kPA		Applicable only to specified load cells 1 v _{min} /1kPA	

The Sector was asked to review the information provided by Mr. Truex, NTEP Administrator, and agree on an appropriate recommendation to address the reported inaccuracies in NCWM Publication 14 Load Cells Table 6 – Example of a Summary Table for a Class III 3000 Single Load Cell (e.g., correcting or deleting Table 6, or other possible solutions).

Conclusion:

Mr. Truex, NTEP Administrator, reported that NCWM Publication 14 Load Cell Table 6 had been created a very long time ago and that the validity of some of the values in the table was currently being questioned. He supported maintaining the table in NCWM Publication 14 and asked that the load cell experts from the WS verify the correctness of the values being questioned. Members of the WS reviewed the values in Table 6 and could not determine how some of the values were determined or derived. Consequently, the WS agreed to maintain this item as a Carryover item on their 2013 agenda to allow additional time for input from load cell experts. It was agreed that Mr. Rusk, Coti Global Sensors; Mr. Upright, Vishay Transducers, Inc.; Mr. Flocken, Mettler-Toledo, Inc.; Mr. Langford, Cardinal Scale Manufacturing, Inc.; and Mr. Harshman, NIST, OWM, would consult with load cell experts in an effort to verify and make corrections to the values in the table where needed. Mr. Harshman offered to consult with Mr. Chesnutwood, NIST Force Lab, regarding this effort.

Shortly after the 2012 WS meeting had concluded, Mr. Chesnutwood provided a review of the values in Table 6 and made corrections where necessary. A corrected version of the table, shown below, incorporating Mr. Chesnutwood’s changes, was then circulated to all members of the Sector who were in attendance at the 2012 WS meeting. Members were asked to vote on whether the corrections to the values in the table should be completed or the item remain as a Carryover item on the 2013 WS agenda. All members responding to the poll, with the exception of one member choosing to abstain, voted in favor of making the corrections included in the table. For this reason, it was decided that the corrected version of the table would be submitted to the NTEP Committee in January 2013 with the recommendation from the WS that it be included in the next version of NCWM Publication 14. Three members of the WS representing load cell manufacturers did not respond to the poll that was

taken. Because those three represented a majority of the load cell manufacturers present during the WS meeting, it was decided that the item would still remain as a Carryover item on the 2013 WS agenda to provide additional confirmation by the WS, including more desired representation by the load cell manufacturers, that the changes made to the table were correct.

Table 6 (Corrected)
Example of a Summary Table for Class III 3000 Single Load Cell

Summary Table (As requested in Item 12 of the load cell data format paper)				
		Critical Result	Tolerance	Result/Tolerance
	Load Cell Error	0.68 v	0.7 v	0.97
	Repeatability Error	0.19 v	0.35 v 0.7 v	0.55 0.27
	Temperature Effect on MDLO	0.57 v _{min} /5 °C	0.7 v _{min} /5 °C	0.82
	Creep (time dependence)	0.98 v	1.5 v 1.05 v	0.65 0.93
	Δ Creep = I _{20 min} – I _{30 min}	0.09 v	0.15 x mpe = 0.225 0.1575 v	0.40 0.57
	Creep Recovery	0.17 v	0.5 v	0.34
	Effect of Barometric Pressure	0.185 v _{min} /kPa	1.0 v _{min} /kPa	0.15

8. NCWM Publication 14, NTEP Administrative Policy

Source

NTEP Administrator

Background/Discussion

NCWM is working to revise NCWM Publication 14, *Administrative Policy* to put it in a more logical order and more understandable form. The purpose is not to change the intent of the publication, rather to realign and clarify sections as necessary. Sectors, Committees, and the NTEP labs are asked to review the revised section, “NTEP Administrative Policy” and provide feedback.

Conclusion:

Mr. Truex reported that the NTEP Board of Directors maintains responsibility of NCWM Publication 14, *Administrative Policy* and that this document had been recently revised and is currently in draft form. A copy of the draft revision was provided to members of the Sector and they were asked to provide a review and report any concerns to Mr. Truex prior to the NTEP Committee meeting planned in early October 2012. Mr. Harshman, OWM, commented that he noticed that the revised draft uses the acronym WMD to reference the NIST Office of Weights and Measures and that a global search of the document should be performed to correct this oversight. The draft revision of NCWM Publication 14, *Administrative Policy* can be found in the NTETC Sector Section of the www.ncwm.net website.

9. Next Sector Meeting

The WS agreed to conduct their next meeting in Albany, New York, on Tuesday and Wednesday, August 27 and 28, 2013. Mr. Morabito, New York State Weights and Measures, was asked by Mr. Truex to provide the names of three hotels in the area to accommodate members of the Sector during their visit. Mr. Morabito stated that Mr. Sikula, Director of New York State Weights and Measures, hopes to be able to offer a tour of the new lab at that time.

APPENDIX A – ATTENDEES

William Arce

USDA, GIPSA, PSP
210 Walnut Street, Suite 317
Des Moines, IA 50014
P. (515) 323-2510
E. william.arce@usda.gov

Steven Beitzel

Systems Associates, Inc.
1932 Industrial Drive
Libertyville, IL 60048
P. (847) 367-6650
E. SJBeitzel@Systemsassoc.com

Luciano Burtini

Measurement Canada
2008 Matera Avenue
Kelowna, BC V1V1W9
P. (250) 862-6557
E. luciano.burtini@ic.gc.ca

Darrell Flocken

Mettler-Toledo, Inc.
1150 Dearborn Drive
Worthington, OH 43085
P. (614) 438-4393
E. darrell.flocken@mt.com

Rick Harshman

NIST, Weights and Measures Division
100 Bureau Drive, Stop 2600
Gaithersburg, MD 20899-2600
P. (301) 975-8107
E. richard.harshman@nist.gov

Ken Jones

California Division of Measurement
Standards
6790 Florin Perkins Road Suite 100
Sacramento, CA 95828
P. (916) 229-3052
E. kenneth.jones@cdfa.ca.gov

Takashi Kawazoe

New Brunswick International Inc.
76 Veronica Ave.
Somerset, NJ 08873
P. (732) 828-3633
E. tkservice@nbidigi.com

Stephen Langford

Cardinal Scale Manufacturing Co.
203 East Daugherty Street
Webb City, MO 64870
P. (417) 673-4631
E. slangford@cardet.com

Paul A. Lewis, Sr.

Rice Lake Weighing Systems, Inc.
230 West Coleman Street
Rice Lake, WI 54868-2404
P. (715) 234-9171 ext.5322
E. plewis@ricelake.com

Ed Luthy

Stock Equipment Co., Inc.
108 Wade Drive
Dover, OH 44622
P. (440) 241-0194
E. ed.luthy@stockequipment.com

Eric Morabito

New York State Weights and Measures
10 B Airline Drive
Albany, NY 12235
P. (518) 457-3452
E. Eric.Morabito@agriculture.ny.gov

Joe Morrison

Ohio Department of Agriculture
Weights and Measures
8995 East Main Street, Building 5
Reynoldsburg, OH 43068
P. (614) 728-6290
E. jmorrison@agri.ohio.gov

Edward Payne

Maryland Department of Agriculture
50 Harry S. Truman Parkway
Annapolis, MD 21401
P. (410) 841-5790
E. edward.payne@maryland.gov

Frank Rusk

Coti Global Sensors
5709 Highway 53
Harvest, AL 35749
P. (256) 852-9900
E. frank@cotiglobal.com

Samuel Sagarsee

Emery Winslow Scale Co.
4530 North 25th Street
Terre Haute, IN 47805
P. (812) 466-5265 ext.112
E. srsagarsee@winslowth.com

Byron School

USDA, GIPSA
1400 Independence Ave. SW
Washington, DC 20250
P. (202) 720-0280
E. Byron.C.School@usda.gov

Louis Straub

Fairbanks Scales, Inc.
3056 Irwin Drive S.E.
Southport, NC 28461
P. (910) 253-3250
E. lstraub@fairbanks.com

James Truex

National Conference on Weights and
Measures
88 Carryback Drive
Pataskala, OH 43062
P. (740) 919-4350
E. jim.truex@ncwm.net

Rob Upright, Jr.

Vishay Transducers
42 Countryside Road
North Grafton, MA 01536
P. (508) 615-1185
E. rob.upright@vishaypg.com

David Vande Berg

Vande Berg Scales
770 7th Street N.W.
Sioux Center, IA 51250
P. (712) 722-1181
E. davevb@vbssys.com

ATTACHMENTS

Attachment to agenda Item-6: Sealing/Capabilities of Smart Junction Boxes

**National Type Evaluation Program
 Digital Controller Element for Load Cells
 Checklists and Test Procedures**

Revision A – Dec 28, 2011

Purpose and Use

This checklist is intended for use when conducting NTEP evaluations of new Digital Controller Elements (DCE) for Load Cells. A DCE for Load Cells is defined as a device that accepts the analog output of one or more cells, converts the load cell output(s) to a single digital value and transmits that value to a display element where it is either displayed or processed further before display. The DCE is typically housed in a separate enclosure and located adjacent to the load cell(s). Calibration of the digital weight signal can take place either within the Digital Controller or within the Digital Weight Indicating (DWI) element. Block diagrams of the three possible types of Load Cell Digital Controller are shown below:

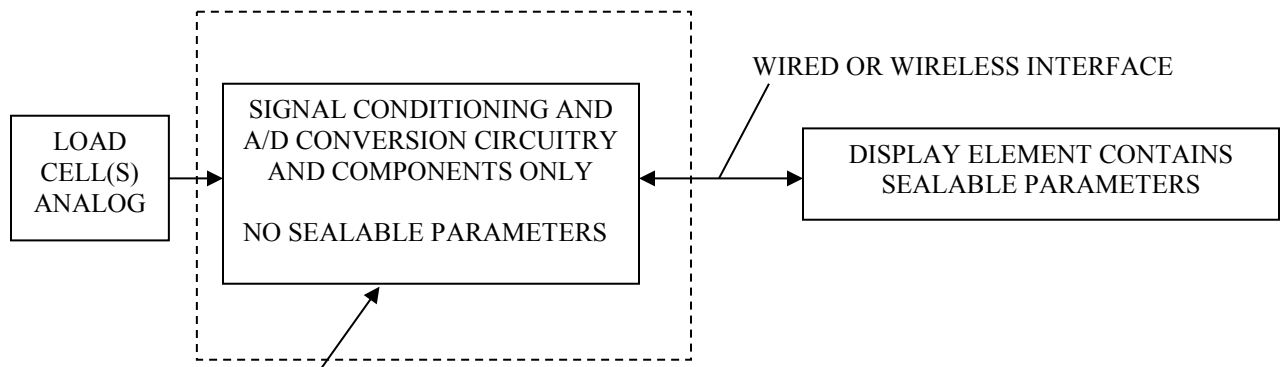

These checklists and test procedures apply if NTEP Certification is ONLY for this portion of the instrument.

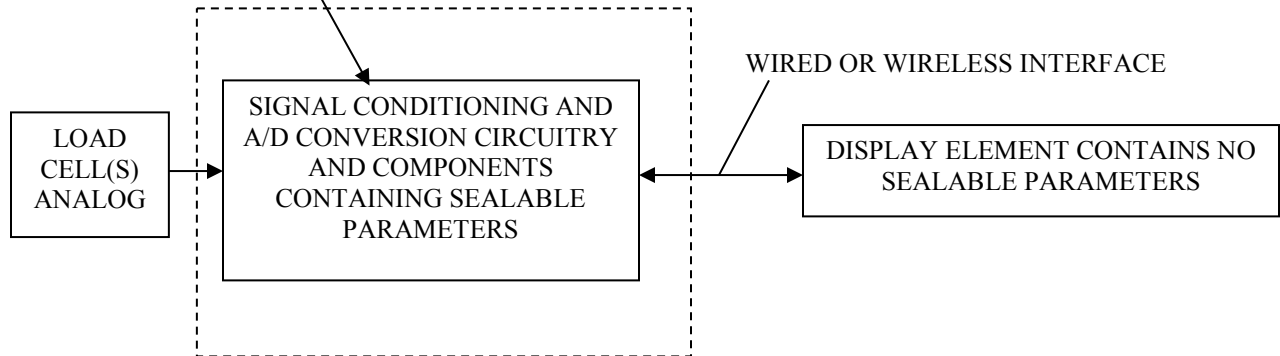

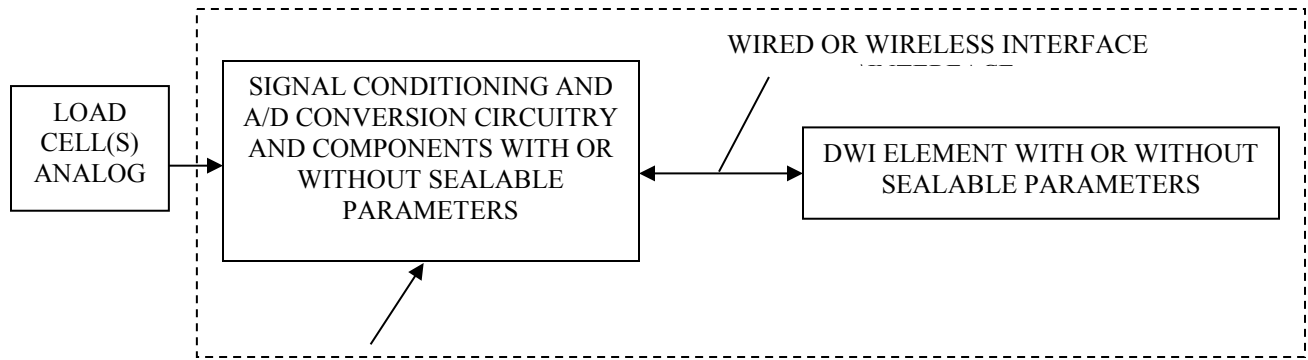

If NTEP Certification is for the signal conditioning element and the DWI element (the whole weight indicating element), use the Digital Electronic Scales (DES) examination procedure.

NTEP Certification is not required for the DCE.

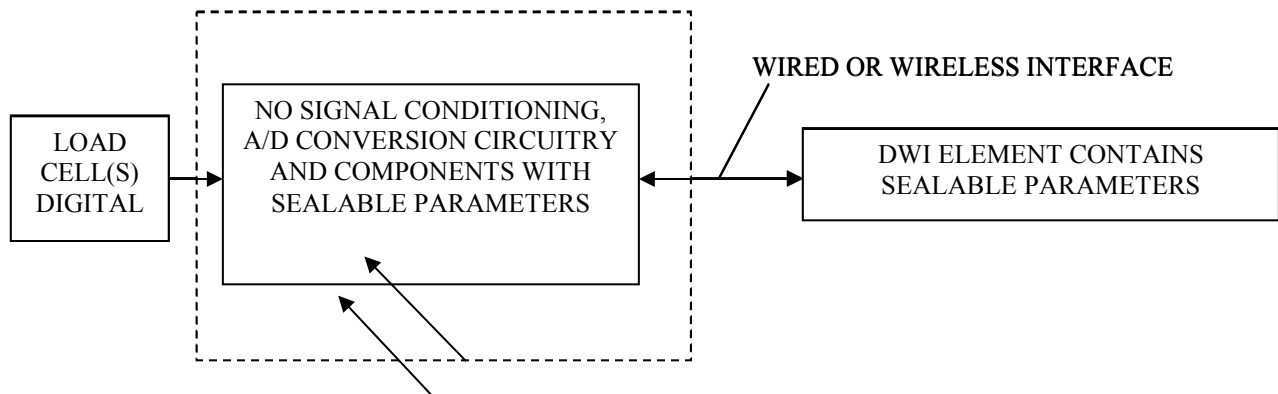

NTEP Certification is required for the DCE.

If both the DCE AND the associated DWI Element are being evaluated as a single component, the test and checklist for Digital Electronic Scales should be used. If only the DCE is being evaluated, use this checklist and test procedure.

The checklist is designed so that the user can determine and record the conformance of the device with the elements of NIST Handbook 44 in a logical sequence. The user should make copies of the checklist to serve as work sheets, preserving the original for reference. In most cases, the results of evaluation for each element can be recorded by checking the appropriate response. In some cases the user is required to record values, results or comments. In those cases, space is provided.

1. Marking Requirements

Code Reference: To Be Determined

The minimum information to be marked on the Load Cell Digital Controller Element (DCE) includes the manufacturer’s ID, the Model Number and Prefix, the Serial Number and Prefix and the Certificate of Conformity Number (CC). If the DCE is intended to operate accurately over a temperature range that is narrower than – 10 °C to 40 °C (14 °F to 104 °F) then the operating temperature range must also be marked on the device. If a narrower temperature range is specified, the range must be at least 54 °F (30 °C). If the DCE contains calibration and setup information to calibrate the weight signal before transmission, it must also contain markings for the accuracy class and n-max. The display element used to display the weight value from this device must contain markings for manufacturer’s ID, the Model Number and Prefix, the Serial Number and Prefix, the Certificate of Conformity Number (CC), the temperature range if not – 10 °C to 40 °C (14 °F to 104 °F), the Nominal Capacity, the Value of the Scale Division “d”, and the value of “e” (required only if different than “d”).

The lettering must be permanent as described in section 1.

- | | | | | |
|-----|--|-----|----|-----|
| 1.1 | The Manufacturer’s ID, the Model Number and Prefix, the Serial Number and Prefix and Certificate of Conformity Number (CC) must be permanently marked on the device. | | | |
| | Manufacturer’s ID | Yes | No | N/A |
| | Model Number and Prefix | Yes | No | N/A |
| | Serial Number and Prefix | Yes | No | N/A |
| | Certificate of Conformity | Yes | No | N/A |
| 1.2 | The operating temperature range shall be marked if different from – 10 °C to 40 °C (14 °F to 104 °F). | Yes | No | N/A |

Figure 1.
Examples of Marking Requirements for Various Device Configurations

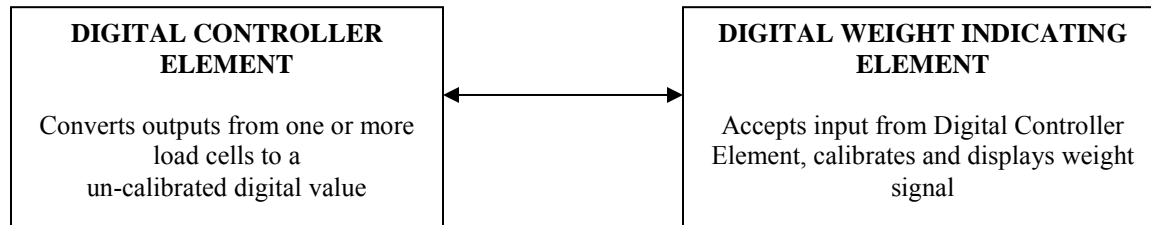

Mark with:
 Manufacturer’s ID
 Model Number and Prefix
 Serial Number and Prefix
 Temperature Range if required
 Certificate of Conformity Number

Mark with:
 Manufacturer’s ID
 Model Number and Prefix
 Serial Number and Prefix
 Temperature Range if required
 Certificate of Conformity Number
 Accuracy Class
 Nominal Capacity
 n-max
 Scale Division d
 Value of e (if different from d)
 CLC (vehicle, axle load and livestock1)
 Section Capacity (for livestock1 and Railway track scales)
 Special Applications

1 See Footnote 14 in Handbook 44 Scales Code Table S.6.3.b.

Marking Requirements for DCEs that Do Not Output a Calibrated Weight Value

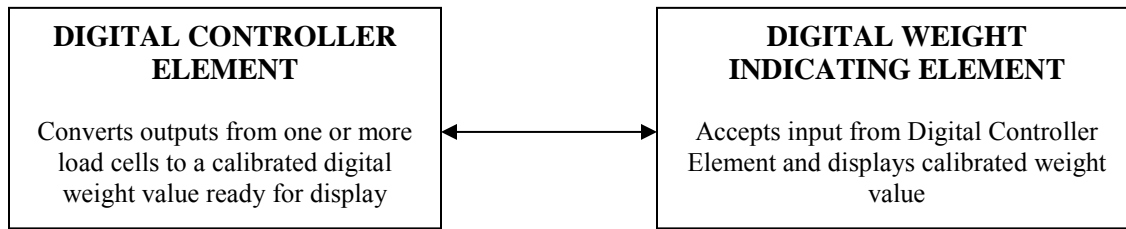

Mark with:

- Manufacturer’s ID
- Model Number and Prefix
- Serial Number and Prefix
- Temperature Range if required
- Certificate of Conformity Number
- Accuracy Class
- Nominal Capacity
- n_{max}
- Scale Division, d
- Value of e (if different from d)
- CLC (vehicle, axle load and livestock¹)

Mark with:

- Manufacturer’s ID
- Model Number and Prefix
- Serial Number and Prefix
- Temperature Range if required
- Certificate of Conformity Number
- Accuracy Class
- Nominal Capacity
- n_{max}
- Scale Division, d
- Value of e (if different from d)
- CLC (vehicle, axle load and livestock¹)
- Section Capacity (for livestock¹ and Railway track scales)
- Special Applications

Marking Requirements for DCEs that Output Calibrated Weight Values

- | | | | | |
|-----|--|-----|----|-----|
| 1.3 | If the device contains calibration data, the Accuracy Class and n-max shall be marked. | Yes | No | N/A |
| 1.4 | The lettering for all markings must be permanent. | Yes | No | N/A |

2. Provision for Metrological Sealing of Adjustable Components or Audit Trail

Code Reference S.1.11.

All components of a weighing instrument must comply with Section 10 of the Digital Electronic Scale Checklist if they have a metrological effect on the instrument or system. DCE features, not addressed in this checklist, may be covered and shall comply with applicable sections in the Digital Electronics Scales Checklist. (See Appendix A – Philosophy for Sealing, Typical Features and Parameters to be Sealed)

Only those DCEs that contain sealable parameters are required to have a means of sealing the adjustments or contain an Audit Trail feature. Those DCEs that ONLY digitize the load cell signal and do not contain any sealable parameters are not required to have security seals or Audit Trails.

Verify that the Digital Controller Element (DCE) does NOT have sealable parameters and cannot adjust the accuracy of the weighing instrument.

- | | | | | |
|-----|--|-----|----|-----|
| 2.1 | Does the Digital Controller Element (DCE) have sealable parameters or features? <i>See table of typical “Scale Features and Parameters” and DES Section 10 Provisions for Metrological Sealing of Adjustable</i> | Yes | No | N/A |
|-----|--|-----|----|-----|

Components or Audit Trail.

2.1.1	If yes, does the DCE Comply with the DES checklist Section 10, Provision for Metrological Sealing of Adjustable Components or Audit Trail?	Yes	No	N/A
	Category 1			
	Category 2			
	Category 3			

3. Test Procedures for Influence Factors

Introduction

Influence factors are environmental variables that might affect the performance of the DCE. Section T.N.8. of the Scales Code in NIST Handbook 44 specifies performance requirements for scales and scale components over given ranges. The test equipment (e.g., thermometers, hygrometers, timing devices) must be sufficiently accurate that their errors do not significantly contribute to the measurement results. The environmental chamber used must meet specified conditions as well. In general, good laboratory practices must be followed.

DCEs can be affected by changes in temperature, changes in the power supply voltage, EMC, interruption of weight data transmission media and possibly humidity depending on enclosure design. The manufacturer of the DCE under evaluation must also provide a compatible DWI element that will be used to indicate the output of the DCE. The following tests are appropriate for those DCEs that only digitize and transmit the weight information as well as those who also calibrate the weight signal and output the weight data in a calibrated format ready for display.

Purpose

The purpose of these tests is to determine the performance and operating characteristics of the DCE under test under loss of communication with the DWI element, at different ambient temperatures, and to determine the temperature effect on the no-load indication.

Pre-Test Conditions

- 3.1 Test Equipment Needed:
 - 3.1.1 Environmental Chamber of sufficient capacity and temperature range
 - 3.1.2 Load Cell Simulator
 - 3.1.3 Calibrated Thermometer and Hygrometers
- 3.2 Device to be Tested
 - 3.2.1 DCE
 - 3.2.2 DWI Element
 - 3.2.3 Interconnecting Cable (not required if interface is wireless)
- 3.3 Conditions of Equipment Under Test
 - 3.3.1 The DCE shall be connected to the Load Cell Simulator following instructions provided in the manufacturer's documentation. Connect the DCE to the DWI Element following the manufacturer's instructions (unless a wireless interface is used). Connect the DCE and the DWI Element to a power source in accordance with the manufacturer's instructions. If equipped with power switch(es), turn both the DWI Element and DCE on and allow them to remain on for a period of time equal to or greater than the manufacturer's recommendations.
 - 3.3.2 Verify that the DCE and DWI Element are operational by observing the weight display in response to changes in the setting of the Load Cell Simulator.
 - 3.3.3 Place the DCE and DWI Element within the environmental chamber and set the temperature to 20 °C (68 °F) or at the mid point of the temperature extremes if a temperature range other than the standard – 10 °C to 40 °C (14 °F to 104 °F) range is specified by the manufacturer.
 - 3.3.4 Prior to beginning the test, verify that the ambient humidity does not exceed 50 % relative humidity and that the DCE and DWI Element are at thermal equilibrium.

3.4 Communications Interface Interruption

3.4.1 The purpose of this test is to ensure that no erroneous weight information is transmitted when the communications interface between the DCE and DWI Element is interrupted. Increase the setting of the Load Cell Simulator until a reading within the range of 500 to 5000 divisions is displayed by the DWI Element. Record the reading. Remove the primary power from the DCE by unplugging its power cord or, if so equipped, remove the battery. If the DCE receives its power from the DWI, it will be necessary to contact the manufacturer to determine the method to be used to disconnect it from its source of power. Observe the DWI Element. The weight value shown by the DWI Element should, within two seconds of interrupting communications, change to either a blank display or error message. It should not be able to display, record, or transmit a weight value under these conditions. Restore power to the DCE. Does the DWI Element indicate an error condition or blank display when the communications with the DCE is interrupted?

Yes No N/A

3.4.2 Repeat the test described in 3.4.1 above but rather than disconnecting the DCE from its power source, disconnect the communications cable or block the wireless signal if so equipped. Does the DWI Element indicate an error condition or blank display when the communications with the DCE is interrupted?

Yes No N/A

3.5 Effect of Temperature on Device Output

Code References: T.N.8.1

3.5.1 The purpose of this test is to determine the effect of changes in temperature on the output of the device. Place the DCE and DWI Elements within the environmental chamber. Connect the Load Cell Simulator or Load Receiving Element to the DCE and place the Load Cell Simulator or Load Receiving Element outside of the environmental chamber. Apply power to the DCE and DWI Elements according to the manufacturer's instructions. Set the environmental chamber to a temperature of 20 °C if the full temperature range is being used or to the mid point of the temperature extremes if a temperature range other than the standard -10 °C to 40 °C (14 °F to 104 °F) range is specified by the manufacturer. If equipped, set the humidity to a setting not greater than 50 % relative humidity. Allow the chamber and equipment under test to reach thermal equilibrium. Verify that these conditions are maintained for a minimum of three hours.

3.5.2 Using the Load Cell Simulator or Load Receiving Element, conduct at least two increasing and two decreasing load tests with at least five different test loads. If the DCE contains calibration settings and transmits a calibrated weight to the DWI Element, the test points shall include the maximum test loads at each tolerance level. If the DCE does not transmit a calibrated weight value to the DWI Element, it is not necessary to include the maximum test load at each tolerance level.

3.5.3 Record the following information at each test load:

- Time and date
- Temperature
- Relative Humidity
- Test Load (mV/V or micro-strain) (or weight if a Load Receiving Element is used)
- Indication
- Error
- Performance Notes if appropriate

- 3.5.4 Increase the temperature of the environmental chamber to the maximum temperature specified by the manufacturer not to exceed 40 °C (104 °F) and allow the device under test to stabilize for at least 3 hours. Stability is assumed to have been reached when the intended temperature is maintained within ± 1 °C (2 °F) for a period of 10 minutes.
- 3.5.5 Record the change in zero, if any, zero if necessary and repeat steps 3.5.2 and 3.5.3.
- 3.5.6 Reduce the temperature to the minimum specified. After the temperature has stabilized according to the definition in 3.5.4, allow the device under test to stabilize for a minimum of 3 hours.
- 3.5.7 Record the change in zero, if any, zero if necessary and repeat steps 3.5.2 and 3.5.3.
- 3.5.8 Increase the temperature to the temperature used in step 3.5.1 and, after the temperature has stabilized, allow the device under test to stabilize for a minimum of 3 hours.
- 3.5.9 Record the change in zero, if any, zero if necessary and repeat steps 3.5.2 and 3.5.3.
- 3.5.10 Additional tests at other temperatures within the specified range of temperatures may be conducted if so desired.
- 3.5.11 If the DCE fails to meet tolerance requirements while conducting the tests in this section of the procedure, the manufacturer has the option of specifying a smaller temperature range. If the DCE failed at only the original specified minimum or maximum temperature, the device need only be tested at the new specified minimum or maximum temperature. It is not required to re-test over the entire newly specified temperature range.
- 3.5.12 If the DCE fails to meet tolerance requirements while conducting the tests in this section of the procedure, the manufacturer may have the option to have the test data reanalyzed for a larger e-min and a smaller n-max. Reanalyzing the data is only appropriate if the data were collected in an expanded display resolution to a resolution of one tenth of the specified e-min or with error weights if a load-receiving element was used in place of the Load Cell Simulator.
- 3.5.13 Before the manufacturer requests a smaller e-min and/or a larger n-max based on the performance during an evaluation, they must submit documentation illustrating the changes made to the device or the manufacturing process, in order to improve the metrological performance of the device. NTEP will require the submission of additional devices for temperature testing.
- 3.5.14 Does the device under test perform over the specified temperature range within tolerance?

Yes No N/A

3.6 Power Voltage Variations

Code References: T.N.8.3.1.

The purpose of varying the power supply voltage is to determine the performance and operating characteristics of the Digital Device Controller that is under test at different voltage levels required by T.N.8.3.1.

If the DCEs provided with an automatic zero tracking device, it may be in operation during the test, in which case the error at zero point shall be determined by recording the error at a test load several intervals above the zero tracking limits.

- 3.6.1 Test Equipment Needed:
 - 3.6.1.1 Variable Power Source
 - 3.6.1.2 Voltmeter
 - 3.6.1.3 Load Cell Simulator or Load Receiving Element
- 3.6.2 The test shall be conducted in a normal laboratory environment.
- 3.6.3 Conditions of Equipment under Test
 - 3.6.3.1 Normal power shall be applied to the DCE and DWI Element for a period of time equal to or greater than the warm-up time specified by the manufacturer.
 - 3.6.3.2 If applicable, the DCE shall be adjusted as closely as practicable to zero error. If the DCE has no adjustments, disregard this step.
 - 3.6.3.3 If equipped with adjustment features, the DCE shall not be adjusted or readjusted at any time during the conduct of this test.
- 3.6.4 Allowable Variations in Test Conditions:
 - 3.6.4.1 $\pm 2\%$ of the power supply
 - 3.6.4.2 All other variables shall be held as nearly as practicable to a normal condition. At least one test cycle shall be conducted.
- 3.6.5 Power Supply Limits
 - 3.6.5.1 As specified in Scale Code in NIST Handbook 44 paragraph T.N.8.3.1.
- 3.6.6 Maximum Allowable Variations
 - 3.6.6.1 All available functions must operate correctly
 - 3.6.6.2 All indications must remain within the tolerances specified in the Scales Code paragraph T.N.3. Tolerance Values for DCEs that produce a calibrated weight value.

POWER SUPPLY TEST

1. With the power supply and equipment under test in the “on” condition, warm up the equipment for a time interval equal to or greater than the manufacturer’s specified minimum warm-up time.
2. Stabilize the power supply output at the nominal voltage $\pm 2\%$.
3. Conduct increasing and decreasing load tests with at least three different test loads, including the maximum test loads at each tolerance level (only if the DCE produces the calibrated weight value).
4. Record the following data:
 - a. Time and Date
 - b. Temperature
 - c. Relative Humidity
 - d. Power Supply Voltage
 - e. Test Load (in mV/V or micro-strain) (or units of mass if a Load Receiving Element is used)
 - f. Indication
 - g. Error
 - h. Any applicable notes pertaining to functions or performance
5. Reduce the power supply to the minimum specified in T.N.8.3.1.
6. Zero if necessary and repeat steps 3 and 4.
7. Increase the power supply voltage to the maximum specified in T.N.8.3.1.
8. Zero, if necessary, and repeat steps 3 and 4.
9. Reduce the power supply voltage to the nominal value.
10. Zero, if necessary, and repeat steps 3 and 4.

Note: Data can be recorded on the Variation of Voltage Report

Form shown at the end of DES section 61.

3.6.7 Are all readings collected during the test within the appropriate tolerance?

Yes No N/A

4. Other Applicable Tests for Digital Controller Elements

4.1	Interchange or Reversal of Parts Does the device under evaluation comply with Section 7 Interchange or Reversal of Parts?	Yes	No	N/A
4.2	Wireless Communications Test Does the device under evaluation comply with DES Sections 11.19 through 11.19.6?	Yes	No	N/A
4.3	Facilitation of Fraud Does the device under evaluation comply with DES Section 19 Facilitation of Fraud – Appropriate Design?	Yes	No	N/A
4.4	RFI/EMI Environment Does the device under evaluation comply with Section 24 RFI/EMI Environment?	Yes	No	N/A
4.5	Installation Requirements Does the device under evaluation comply with Section 25 Installation Requirements?	Yes	No	N/A
4.6	Discrimination and Zone of Uncertainty Does the device under evaluation comply with Section 44 Discrimination and Zone of Uncertainty?	Yes	No	N/A
4.7	Temperature and Performance Tests (General) Does the device under evaluation comply with Section 54 Temperature and Performance Tests?	Yes	No	N/A

Report of the Nominating Committee

Mr. Kurt Floren, Committee Chair
Los Angeles County, California

800 INTRODUCTION

The Nominating Committee (hereinafter referred to as the “Committee”) met during the 98th National Conference on Weights and Measures (NCWM) Interim Meeting, January 27 - 30, 2013, in Charleston, South Carolina. At that time, the Committee nominated persons for the various available Board of Director positions for the 99th NCWM. The following report reflects the decisions of the NCWM membership.

Table A identifies the agenda items by reference key, title of item, page number and the appendices by appendix designations. Table B reflects the Summary of Voting Results.

**Table A
Table of Contents**

Reference Key	Title of Item	NOM Page
800	INTRODUCTION	1
810	NOMINATIONS	2
810-1	V Officer Nominations	2

**Table B
Summary of Voting Results**

<i>Reference Key Number</i>	<i>House of Senate Representatives</i>		<i>House of Delegates</i>		<i>Results</i>
	<i>Yeas</i>	<i>Nays</i>	<i>Yeas</i>	<i>Nays</i>	
810-1	Voice Vote of Business Items as amended by Committee				Adopted
To Accept the Report	Voice Vote				Adopted

Details of All Items
(In order by Reference Key)

810 NOMINATIONS

810-1 V Officer Nominations

(This item was adopted by unanimous vote of the 98th National Conference on Weights and Measures)

Source:

Nominating Committee

Purpose:

Election of NCWM officers

Item Under Consideration:

The following slate of officers was selected by unanimous vote of the committee:

Chairman-Elect:

Mr. Ronald Hayes, Missouri Weights and Measures

Board of Directors Active Director - Southern: (5 years)

Mr. Kenneth Ramsburg, Maryland Department of Agriculture

Board of Directors Associate Director: (3 years)

Mr. Christopher Guay, Proctor & Gamble Co.

Board of Directors At-Large Director: (5years)

Mr. Chuck Corr, Archer Daniels Midland Co.

Treasurer: (1 year)

Mr. Mark Coyne, Brockton, Massachusetts Weights and Measures

Background/Discussion:

The Nominating Committee met during the 2013 Interim Meeting at the Francis Marion Hotel, Charleston, South Carolina, at which time the Committee nominated the persons listed above to be officers of the 99th National Conference on Weights and Measures. In the selection of nominees from the active and associate membership, consideration was given to professional experience, qualifications of individuals, conference attendance and participation, and other factors considered to be important.

At the Annual Meeting, held in Louisville, Kentucky, the above nominations were selected by unanimous voice vote to serve on the Board of Directors.

Mr. Kurt Floren, Los Angeles County | Committee Chair
Ms. Judy Cardin, Wisconsin | Member
Mr. Thomas Geiler, Barnstable Weights and Measures | Member
Mr. Joe Gomez, New Mexico | Member
Mr. Maxwell Gray, Florida | Member
Mr. Randy Jennings, Tennessee | Member
Mr. Tim Tyson, Kansas | Member

Nominating Committee

98th Annual Meeting Attendees

Sprague Ackley

Intermec
6001 36th Avenue, W
Everett, WA 98203
Phone: (425) 501-8995
E-mail: hsackley@cs.com

Cary Ainsworth

USDA, GIPSA
75 Spring Street, Suite 230
Atlanta, GA 30303-3309
Phone: (404) 562-5426
E-mail: l.cary.ainsworth@usda.gov

John Albert

Missouri Department of Agriculture
1616 Missouri Boulevard
P.O. Box 630
Jefferson City, MO 65102
Phone: (573) 751-7062
E-mail: John.Albert@mda.mo.gov

Mahesh Albuquerque

CDLE-Oil and Public Safety
633 17th Street, Suite 500
Denver, CO 80202
Phone: (303) 318-8502
E-mail: mahesh.albuquerque@state.co.us

S. Chris Anders

Zeltex Inc.
130 Western Maryland Parkway
Hagerstown, MD 21740
Phone: (301) 791-7080
E-mail: canders@zeltex.com

Ross Andersen

25 Moon Drive
Albany, NY 12205
Phone: (518) 869-7334
E-mail: rjandersen12@gmail.com

Paige Anderson

National Association of Convenience Stores
1600 Duke Street
Alexandria, VA 22314
Phone: (703) 518-4221
E-mail: panderson@nacsonline.com

Cheryl Ayer

New Hampshire Department of
Agriculture Markets and Food
25 Capitol Street
Concord, NH 03302
Phone: (603) 568-3387
E-mail: cheryl.ayer@agr.nh.gov

Jason Barber

Oregon Measurement Standards Division
635 Capitol Street, NE
Salem, OR 97301
Phone: (503) 986-4767
E-mail: jbarber@oda.state.or.us

Todd Barrows

Elkhart County Weights & Measures
117 N 2nd, Room 107
Goshen, IN 46526-3231
Phone: (574)535-6472
E-mail: tbarrows@elkhartcounty.com

John Barton

NIST, Office of Weights and Measures
100 Bureau Drive, MS 2600
Gaithersburg, MD 20899-2600
Phone: (301) 975-4002
E-mail: john.barton@nist.gov

Steve Beitzel

Systems Associates, Inc.
1932 Industrial Drive
Libertyville, IL 60048
Phone: (847) 367-6650
E-mail: sjbeitzel@systemsassoc.com

Sam Bell

Echols Oil Company, Inc.
P.O. Box 1477
Greenville, SC 29602
Phone: (864) 233-6205
E-mail: info@scpma.com

Attendees – 2013 Final Report

Mike Belue

Belue Associates
139 Whisperwood Trail.
Florence, AL 35633
Phone: (256) 768-2994
E-mail: Bassoc@aol.com

Joe Benavides

Texas Department of Agriculture
1700 North Congress Avenue
Stephen F. Austin Building, 11th Floor
Austin, TX 78701
Phone: (512) 463-5706
E-mail: joe.benavides@texasagriculture.gov

Stephen Benjamin

North Carolina Department of
Agriculture and Consumer Services
1050 Mail Service Center
Raleigh, NC 27699-1050
Phone: (919) 733-3313
E-mail: steve.benjamin@ncagr.gov

Ann Boeckman

Kraft Foods Group, Inc.
Three Lakes Drive
Northfield, IL 60093
Phone: (847) 646-2862
E-mail: ann.boeckman@kraftfoods.com

Adam Bolain

Heinz North America
357 6th Avenue
Pittsburgh, PA 15222
Phone: (724) 778-5640
E-mail: adam.bolain@us.hjheinz.com

David Boykin

NCR Corporation
200 Highway 74 South
Peachtree City, GA 30269
Phone: (770) 288-1556
E-mail: db123643@ncr.com

Tim Broemmer

Avery Weigh-Tronix
272 Botanical Ridge Drive
Wentzville, MO 63385
Phone: (913) 617-9176
E-mail: tbroemmer@awtxglobal.com

Josh Brown

NorthStar Inc.
1600 Union Road
Evanston, WY 82930
Phone: (307) 789-5088
E-mail: jbrown@northstarlng.com

Norm Brucker

Precision Measurement Standards, Inc.
1665 Bonaire Path West
Rosemount, MN 55068
Phone: (651) 423-3241
E-mail: sharnoma@frontiernet.net

Jerry Buendel

Washington State Department of Agriculture
1111 Washington Street
P.O. Box 42560
Olympia, WA 98504-2560
Phone: (360) 902-1856
E-mail: jbuendel@agr.wa.gov

Luciano Burtini

Measurement Canada
2008 Matera Avenue
Kelowna, BC V1V 1W9
Phone: (250)862-6557
E-mail: luciano.burtini@ic.gc.ca

Tina Butcher

NIST, Office of Weights and Measures
100 Bureau Drive, MS 2600
Gaithersburg, MD 20899
Phone: (301) 975-2196
E-mail: tina.butcher@nist.gov

Jerry Butler

North Carolina Department of Agriculture
1050 Mail Service Center
Raleigh, NC 27699-1050
Phone: (919) 733-3313
E-mail: jerry.butler@ncagr.gov

John Cabaniss

Association of Global Automakers
1050 K Street, NW #650
Washington, DC 20001
Phone: (202) 650-5562
E-mail: jcabaniss@globalautomakers.org

David Calix

NCR Corporation
1510 North Walton Boulevard
Bentonville, AR 72712
Phone: (479) 372-8407
E-mail: david.calix1976@gmail.com

Bill Callaway

Crompco
1815 Gallagher Road
Plymouth Meeting, PA 19067
Phone: (610) 256-7185
E-mail: bill.callaway@crompco.com

Stacy Carlsen

Marin County Weights and Measures
1682 Novato Boulevard, Suite 150-A
Novato, CA 94947-7021
Phone: 415-473-6700
E-mail: scarlsen@marincounty.org

Charlie Carroll

Massachusetts Division of Standards
One Ashburton Place, Room 1115
Boston, MA 02108
Phone: (617) 727-3480
E-mail: Charles.Carroll@state.ma.us

Jimmy Cassidy

City of Cambridge Weights
and Measures Department
831 Massachusetts Avenue
Cambridge, MA 02139
Phone: (617) 349-6133
E-mail: jcassidy@cambridgema.gov

Clarence Chee

Navajo Nation Business Regulatory Department
HWY 264, 100 Taylor Rd, Suite 210
St. Michaels, AZ 86511
Phone: (928) 871-6718
E-mail: locohorse99@yahoo.com

Tim Chesser

Arkansas Bureau of Standards
4608 West 61st Street
Little Rock, AR 72209
Phone: (501) 570-1159
E-mail: tim.chesser@aspb.ar.gov

Sherri Cionciarulo

City of Chicago
2350 W. Ogden
Chicago, IL 60608
Phone: (312) 743-9103
E-mail: sherri.cionciarulo@cityofchicago.org

Brian Clark

Kentucky Petroleum Marketers Association
2365 Harrodsburg Road, Suite A325
Lexington, KY 40504
Phone: (859) 226-4374
E-mail: brian.clark@kpma.net

John Cook

Kentucky Department of Agriculture
107 Corporate Drive
Frankfort, KY 40601
Phone: 502-573-0282
E-mail: johnr.cook@ky.gov

Clark Cooney

Retired
Salem, OR
Phone: (503) 986-4677
E-mail: ccooney@oda.state.or.us

Rodney Cooper

Tuthill Transfer Systems
8825 Aviation Drive
Fort Wayne, IN 46809
Phone: (260) 755-7552
E-mail: rcoper@tuthill.com

Chuck Corr

Archer Daniels Midland Company
1251 Beaver Channel Parkway
Clinton, IA 52732
Phone: (563) 244-5208
E-mail: corr@adm.com

Constantine Cotsoradis

Flint Hills Resources
4111 East 37th Street North
Wichita, KS 67220-3203
Phone: (316) 828-6133
E-mail: constantine.cotsoradis@fhr.com

Mark Coyne

Brockton Weights and Measures
45 School Street, City Hall
Brockton, MA 02301-9927
Phone: (508) 580-7120
E-mail: mcoyne@cobma.us

Jim Creevy

National Electrical Manufacturers Association
(NEMA)
1300 North 17th St, Suite 1752
Arlington, VA 22209
Phone: (703) 841-3265
E-mail: jim.creevy@nema.org

Attendees – 2013 Final Report

Matthew Curran

Florida Department of Agriculture
and Consumer Services
3125 Conner Boulevard
Building 1, Mail Stop L1
Tallahassee, FL 32399-1650
Phone: (850) 921-1570
E-mail: matthew.curran@freshfromflorida.com

Ha Dang

San Diego County Department of Agriculture
Weights and Measures
9325 Hazard Way, Suite 100
San Diego, CA 92123-1217
Phone: (858) 614-7703
E-mail: ha.dang@sdcounty.ca.gov

Matt Daus

International Association of
Transportation Regulators
156 West 56th Street, 22nd Floor
New York, NY 10019
Phone: (646) 261-1590
E-mail: cmanning@windelsmarx.com

Bill Deitz

Sam's Club
2101 Simple Savings Drive
Bentonville, AR 72712
Phone: (479) 277-7595
E-mail: bill.deitz@samsclub.com

Rob DeRubeis

Michigan Department of Agriculture
and Rural Development
940 Venture Lane
Williamston, MI 48895
Phone: (517) 655-8202
E-mail: derubeisr@michigan.gov

Wes Diggs

7508 Oakmont Drive
Henrico, VA 23228
Phone: (804) 264-3461
E-mail: westonclubs14@aol.com

John Eichberger

National Association of Convenience Stores
1600 Duke Street
Alexandria, VA 22314
Phone: (703) 518-4247
E-mail: jeichberger@nacsonline.com

Bob Feezor

Scales Consulting and Testing
35 Stonington Place
Marietta, GA 30068
Phone: (770) 971-7454
E-mail: rkfeezor@bellsouth.net

Kevin Ferrick

API
1220 L Street, NW
Washington, DC 20005
Phone: (202) 682-8233
E-mail: ferrick@api.org

Mark Flint

Archer Daniels Midland
4666 Faries Parkway
Decatur, IL 62526
Phone: (217) 451-3104
E-mail: mark.flint@adm.com

Darrell Flocken

Mettler-Toledo, LLC
1150 Dearborn Drive
Worthington, OH 43085
Phone: (614) 438-4393
E-mail: darrell.flocken@mt.com

Kurt Floren

LA County Agricultural Commissioner
Weights and Measures
12300 Lower Azusa Road
Arcadia, CA 91006
Phone: (626) 575-5451
E-mail: kflore@acwm.lacounty.gov

John Gaccione

Westchester County Weights and Measures
148 Martine Avenue, Room 407
White Plains, NY 10601
Phone: (914) 995-2164
E-mail: jpg4@westchestergov.com

Win Gardner

ExxonMobil Corporation
3225 Gallows Rd, Rm 6D0416
Fairfax, VA 22037
Phone: (703) 846-5400
E-mail: k.w.gardner@exxonmobil.com

Tom Geiler

Town of Barnstable
200 Main Street
Hyannis, MA 02601
Phone: (508) 862-4670
E-mail: tom.geiler@town.barnstable.ma.us

Bill Geubelle

Phillips 66
1000 S Pine
Ponca City, OK 74602
Phone: (580) 767-3400
E-mail: bill.g.geubelle@p66.com

Steve Giguere

Maine Department of Agriculture
28 State House Station
Augusta, ME 04333
Phone: (207) 287-4456
E-mail: steve.giguere@maine.gov

Jason Glass

Kentucky Department of Agriculture
107 Corporate Drive
Frankfort, KY 40601
Phone: (502) 573-0282
E-mail: jason.glass@ky.gov

Paul Glowacki

Murray Equipment, Inc.
2515 Charleston Place
Fort Wayne, IN 46805
Phone: (260) 480-1352
E-mail: pglowacki@murrayequipment.com

Angela Godwin

Ventura County Department of Weights
and Measures, California
800 S Victoria Avenue, #1750
Ventura, CA 93009
Phone: (805) 654-2428
E-mail: angela.godwin@ventura.org

Joe Gomez

New Mexico Department of Agriculture
P.O. Box 30005, MSC 3170
Las Cruces, NM 88003-8005
Phone: (575) 646-1616
E-mail: jgomez@nmda.nmsu.edu

Steve Grabski

Walmart Stores, Inc.
508 SW 8th Street, MS 0505
Bentonville, AR 72712
Phone: (479) 277-8005
E-mail: steven.grabski@wal-mart.com

Max Gray

Florida Department of Agriculture
and Consumer Services
3125 Conner Boulevard
Building 1, MS L1
Tallahassee, FL 32399-1650
Phone: (850) 921-1570
E-mail: maxwell.gray@freshfromflorida.com

Charley Greene, Ph.D.

Camino Del Rex
Las Cruces, NM 88001
Phone: (575) 523-0730
E-mail: cgreene1932@yahoo.com

Frank Greene

Connecticut Dept of Consumer Protection
165 Capitol Avenue
Hartford, CT 06106
Phone: (860) 713-6168
E-mail: frank.greene@ct.gov

LuAnne Groenjes

National Conference on Weights
and Measures, Inc.
1135 M Street, Suite 110
Lincoln, NE 68508
Phone: (402) 434-4880
E-mail: luanne.groenjes@ncwm.net

Chris Guay

Procter and Gamble Co.
One Procter and Gamble Plaza
Cincinnati, OH 45202
Phone: (513) 983-0530
E-mail: guay.cb@pg.com

Brett Gurney

Utah Department of Agriculture and Food
P.O. Box 146500
Salt Lake City, UT 84114-6500
Phone: (801) 538-7158
E-mail: bgurney@utah.gov

Krister Hard af Segerstad

IKEA North America Services, LLC
420 Alan Wood Road
Conshohocken, PA 19428
Phone: (610) 834-0180
E-mail: krister.hardafsegerstad0@ikea.com

Attendees – 2013 Final Report

John Harkins

Sunoco Logistics
4041 Market Street
Aston, PA 19014
Phone: (610) 833-3671
E-mail: jjharkins@sunocologistics.com

Rick Harshman

NIST, Office of Weights and Measures
100 Bureau Drive, MS 2600
Gaithersburg, MD 20899-2600
Phone: (301) 975-8107
E-mail: richard.harshman@nist.gov

Ryanne Hartman

Michigan Department of Agriculture
and Rural Development
940 Venture Lane
Williamston, MI 48895-2451
Phone: (517) 655-8202
E-mail: hartmanr9@michigan.gov

Scott Hartman

Shell
777 Walker Street
Houston, TX 77002
Phone: (713) 598-9158
E-mail: scott.hartman@shell.com

Ron Hayes

Missouri Department of Agriculture
1616 Missouri Boulevard
P.O. Box 630
Jefferson City, MO 65102
Phone: (573) 751-4316
E-mail: ron.hayes@mda.mo.gov

Scott Henry

Motorola Solutions, Inc.
1700 Belle Meade Court
Lawrenceville, GA 30043
Phone: (770) 338-3884
E-mail: scott.henry@motorolasolutions.com

Maureen Henzler

Kansas Department of Agriculture
Phone: P.O. Box 19282
Topeka, KS 66619
Phone: (785) 862-2415
E-mail: maureen.henzler@kda.ks.gov

Marilyn Herman

Herman and Associates
3730 Military Road, NW
Washington, DC 20015
Phone: (202) 362-9520
E-mail: mherman697@aol.com

Maile Hermida

Hogan Lovells US, LLP
555 13th Steet, NW
Washington, DC 20004
Phone: (202) 637-5428
E-mail: maile.hermida@hoganlovells.com

Mike Hoar

New World Pasta
2360 Propect Street
Memphis, TN 38106
Phone: (502) 396-1746
E-mail: mhoar@nwpasta.com

Carol Hockert

NIST, Office of Weights and Measures
100 Bureau Drive, MS 2600
Gaithersburg, MD 20899-2600
Phone: (301) 975-4004
E-mail: carol.hockert@nist.gov

Jerry Horn

Chevron Global Downstream, LLC
100 Chevron Way, Room 61-4228
Richmond, CA 94802
Phone: (510) 242-1367
E-mail: jerryhorn@chevron.com

Bill Hornbach

Chevron Products Company
6001 Bollinger Canyon Road
San Ramon, CA 94583
Phone: (925) 842-3484
E-mail: billhornbach@chevron.com

Doug Horne

Clean Vehicle Education Foundation
3011 Fords Lake Court NW
Acworth, GA 30101
Phone: (770) 424-8575
E-mail: dbhorne1@comcast.net

Fran Houston

Ohio Department of Agriculture
Division of Weights and Measures
8995 East Main Street
Reynoldsburg, OH 43068
Phone: (614) 728-6290
E-mail: houston@agri.ohio.gov

John Hughes

Rice Lake Weighing
230 W Coleman Street
Rice Lake, WI 54868
Phone: (507) 399-4629
E-mail: jhughes@ricelake.com

Mark James

Frias Transportation
5010 S. Valley View Boulevard
Las Vegas, NV 89118
Phone: (702) 798-3424
E-mail: kat@friaslasvegas.com

Randy Jennings

Tennessee Department of Agriculture
P.O. Box 40627
Melrose Station
Nashville, TN 37204
Phone: (615) 837-5327
E-mail: randy.jennings@tn.gov

Paul Jeran

Hewlett-Packard Company
11311 Chinden Boulevard
Boise, ID 83714
Phone: (208) 396-6144
E-mail: paul.jeran@hp.com

Rafael Jimenez

Association of American Railroad
Transportation Technology Center
P.O. Box 11130
55500 D.O.T. Road
Pueblo, CO 81001
Phone: (719) 584-0691
E-mail: rafael_jimenez@ttci.aar.com

Joanna Johnson

Johnson Policy Associates, Inc.
P.O. Box 13302
Des Moines, IA 50310
Phone: (515) 277-4320
E-mail: jpa.inc@earthlink.net

Gordon Johnson

Gilbarco, Inc.
7300 West Friendly Avenue
Greensboro, NC 27410
Phone: (336) 547-5375
E-mail: gordon.johnson@gilbarco.com

Raymond Johnson Jr.

New Mexico Department of Agriculture
P.O. Box 30005, MSC 3170
Las Cruces, NM 88003-8005
Phone: (575) 646-1616
E-mail: rjohnson@nmda.nmsu.edu

Dave Jones

Nevada Division of Measurement Standards
2150 Frazer Avenue
Sparks, NV 89431
Phone: (775) 353-3782
E-mail: djones@agri.nv.gov

Murray Jones

ECotality
430 S. 2nd Avenue
Phoenix, AZ 85003
Phone: (480) 526-8414
E-mail: mjones@ecotality.com

Zina Juroch

Pier 1 Imports
100 Pier 1 Place
Fort Worth, TX 76102
Phone: (817) 252-8348
E-mail: zmjuroch@pier1.com

Henry Kellogg

Compucom
2 Cromer Drive
Bella Vista, AR 72715
Phone: (479) 685-6862
E-mail: henry.kellogg@compucom.com

Cindy Kennard

Marathon Petroleum Company, LP
1000 Ashland Drive, Suite 201
Ashland, KY 41101-7057
Phone: (606)326-2519
E-mail: clkennard@marathonpetroleum.com

Michael Kerr

Southern Company Services
228 Bridle Run
Somerset, KY 42503
Phone: (606) 305-2419
E-mail: mlkerr@southernco.com

Doug Killingsworth

Georgia Department of Agriculture
19 M.L.K. Jr. Drive. SW
Atlanta, GA 30334
Phone: (404) 656-3605
E-mail: william.killingsworth@agr.georgia.gov

Attendees – 2013 Final Report

Jeri Kahana

Hawaii Department of Agriculture
1851 Auiki Street
Honolulu, HI 96819
Phone: (808) 832-0707
E-mail: Jeri.M.Kahana@hawaii.gov

Dmitri Karimov

Liquid Controls
105 Albrecht Drive
Lake Bluff, IL 60044
Phone: (847) 283-8317
E-mail: dkarimov@idexcorp.com

Michael Keilty

Endress + Hauser Flowtec AG USA
2441 Arapaho Road
Estes Park, CO 80517
Phone: (970) 586-2122
E-mail: michael.keilty@us.endress.com

Vance Kopp

Weaver LLP
24 Greenway Plaza, Suite 1800
Houston, TX 77057
Phone: (720) 279-3011
E-mail: vance.kopp@weaverllp.com

Jason Kukachka

Thermo Fisher Scientific
501 90th Avenue, N.W
Coon Rapids, MN 55433
Phone: (763) 783-2566
E-mail: jason.kukachka@thermofisher.com

Archie Lambert

Louisiana Dept. of Agriculture and Forestry
P.O. Box 3098
Baton Rouge, LA 70821-3098
Phone: (225) 925-3780
E-mail: archie_l@ldaf.state.la.us

Stephen Langford

Cardinal Scale Manufacturing Co.
203 East Daugherty Street
P.O. Box 151
Webb City, MO 64870
Phone: (417) 673-4631
E-mail: slangford@cardet.com

Robert Legg

Southwest Research Institute
6220 Culebra Road
San Antonio, TX 78238
Phone: (210) 522-2071
E-mail: robert.legg@swri.org

Jeff Lewelling

City of Chicago
2350 W. Ogden
Chicago, IL 60608
Phone: (312) 744-5404
E-mail: jeffrey.lewelling@cityofchicago.org

Paul Lewis

Rice Lake Weighing Systems, Inc.
230 West Coleman Street
Rice Lake, WI 54868-2404
Phone: (715) 434-5322
E-mail: plewis@ricelake.com

Rich Lewis

Georgia Department of Agriculture
Agriculture Building, 19 MLK Drive, Rm. 321
Atlanta, GA 30334
Phone: (404) 656-3605
E-mail: richard.lewis@agr.georgia.gov

Russ Lewis

Marathon Petroleum Company LP
2901 Camelia Drive
Flatwoods, KY 41139
Phone: (606) 921-2009
E-mail: rplewis@marathonpetroleum.com

Tim Lloyd

Montana Weights and Measures Bureau
P.O. Box 200516
Helena, MT 59620-0516
Phone: (406) 443-3289
E-mail: tlloyd@mt.gov

Rick Long

RDM Industrial Electronics
850 Harmony Grove Road
Nebo, NC
Phone: (828) 652-8346
E-mail: rick@rdm.net

Girard Lukowiak

City of East Orange
143 New Street
East Orange, NJ 07017
Phone: (201) 953-4260
E-mail: glukowiak@gmail.com

Ed Luthy

Schenck Process
108 Wade Drive
Dover, OH 44622
Phone: (440) 241-0194
E-mail: e.luthy@schcnckprocess.com

Rodney Lynch

Navajo Nation Weights and Measures
P.O. Box 663
Window Rock, AZ 86515
Phone: (928)871-7367
E-mail: lynch_rodney@yahoo.com

Andrew MacAllister

Daniel Measurement and Control, Inc.
11100 Brittmoore Park Drive
Houston, TX 77041
Phone: (713) 827-4334
E-mail: andrew.macallister@emerson.com

Kristin Macey

California Division of Measurement Standards
6790 Florin Perkins Rd, Suite 100
Sacramento, CA 95828
Phone: 916-229-3000
E-mail: kristin.macey@cdfa.ca.gov

Roger Macey

Retired
Elk Grove, CA 95624
E-mail: romac@softcom.net

Matthew Maiten

Santa Barbara County Agriculture Commissions
263 Camino del Remedio
Santa Barbara, CA 93110
Phone: (805) 681-5600
E-mail: mmaiten@agcommissioner.com

Marco Mares

San Diego County Dept of Agriculture
Weights and Measures
9325 Hazard Way, Suite 100
San Diego, CA 92123-1256
Phone: (858) 614-7726
E-mail: marco.mares@sdcounty.ca.gov

Devin Martin

NorthStar, Inc.
P.O. Box 1342
Evanston, WY 82931
Phone: (307) 789-5088
E-mail: dmartin@northstarlng.com

Dr. Willie May

NIST, Office of Weights and Measures
100 Bureau Drive, MS 2600
Gaithersburg, MD 20899-2600

Rich McComas

West Virginia Weights and Measures
Division of Labor
570 McCorkle Avenue West
St. Albans, WV 25177
Phone: (304) 722-0602
E-mail: rich.d.mccomas@wv.gov

Jim McGetrick

BP Products
Mail Code J-8
150 W. Warrenville Road
Naperville, IL 60563
Phone: (630) 487-1685
E-mail: james.mcgetrick@bPhonecom

Bob McGrath

Boston ISD Weights and Measures
1010 Massachusetts Avenue
Boston, MA 02118
Phone: (617) 961-3376
E-mail: Robert.Mcgrath@CityofBoston.gov

Paul Menard

Lexmark International
740 West New Circle Road
501C14/082-1
Lexington, KY 40550
Phone: (859) 232-7379
E-mail: menard@lexmark.com

Dan Middleton

Texas A&M University
3135 Tamu
College Station, TX 77843
Phone: (979) 229-4785
E-mail: d-middleton@tamu.edu

Kristy Moore

Renewable Fuels Association
425 3rd Street, SW, Suite 1150
Washington, DC 20024
Phone: (309) 830-6154
E-mail: kmoore@ethanolrfa.org

Joe Moreo

Modoc County Department of Agriculture
202 West Fourth Street
Alturas, CA 96101
Phone: (530)233-6401
E-mail: susiephilpott@co.modoc.ca.us

Attendees – 2013 Final Report

Paul Moyer

Nebraska Division of Weights and Measures
301 Centennial Mall South, Box 94757
Lincoln, NE 68509-4757
Phone: (402) 471-6842
E-mail: paul.moyer@nebraska.gov

Bob Murnane

Seraphin Test Measure, Co.
30 Indel Avenue
P.O. Box 227
Rancocas, NJ 08073-0227
Phone: (609) 267-0922
E-mail: rmurnane@pemfab.com

Bob Nelson

Shell Oil Products
1000 Main Street, Level 12
Houston, TX 77002
Phone: (713) 230-5143
E-mail: robert.e.nelson@shell.com

Josh Nelson

Oregon Department of Agriculture
635 Capitol Street, NE
Salem, OR 97301-2532
Phone: (503) 986-4751
E-mail: jnelson@oda.state.or.us

Laurence Nolan

LA County Agriculture Commission
Weights & Measures
11012 Garfield Avenue
South Gate, CA 90280
Phone: (562)940-8936
E-mail: lnolad@acwm.lacounty.gov

Neal Nover

WinWam Software
3000 Atrium Way, Suite 2203
Mount Laurel, NJ 08054-3910
Phone: (856) 273-6988
E-mail: NealNov@winwam.com

Pete O'Bryan

Foster Farms
P.O. Box 457
Livingston, CA 95334-9900
Phone: (209) 765-4978
E-mail: Pete.obryan@fosterfarms.com

Don Onwiler

National Conference on Weights
and Measures, Inc.
1135 M Street, Suite 110
Lincoln, NE 68508
Phone: (402) 434-4871
E-mail: don.onwiler@ncwm.net

Henry Oppermann

Weights and Measures Consulting, LLC
1300 Peniston Street
New Orleans, LA 70115
Phone: (504) 896-9172
E-mail: wm-consulting@att.net

Everett Osgood

MidContinental Chemical Co, Inc
1802 East 123rd Terrace
Olathe, KS 66061
Phone: 913-390-5556
E-mail: everetto@mcchemical.com

Nick Owens

Stark County Weights and Measures
225 4th Street, NE
Canton, OH 44702
Phone: (330) 451-7356
E-mail: njowens@co.stark.oh.us

Tom Palace

PMCA of Kansas
P.O. Box 678
Topeka, KS 66601
Phone: (785) 233-9655
E-mail: tom@pmcaofks.org

David Paul

RideCharge, Inc. dba Taxi Magic
229 Berkeley Street, #400
Boston, ma 02116
Phone: (703) 579-6911
E-mail: dmp@taximagic.com

Hank Picken

Beaumont Products, Inc
1560 Big Shanty Drive
Kennesaw, GA 30144
Phone: (770) 514-9000
E-mail: kpicken@beaumontproducts.com

Ronda Powell

Georgia-Pacific LLC
133 Peachtree Street, NE
9th Floor
Atlanta, GA 30303
Phone: (404) 652-2610
E-mail: ronda.powell@gapac.com

Julie Quinn

Minnesota Department of Commerce
14305 South Cross Drive, Suite 150
Burnsville, MN 55306
Phone: (651) 539-1555
E-mail: julie.quinn@state.mn.us

Dave Rajala

Total Meter Services, Inc.
136 Queen Anne Drive
Hollidaysburg, PA 16648-9228
Phone: (814) 693-1055
E-mail: drajala@totalmeter.com

Ken Ramsburg

Maryland Department of Agriculture
50 Harry S. Truman Parkway
Annapolis, MD 21401
Phone: (410) 841-5790
E-mail: kenneth.ramsburg@maryland.gov

Doug Rathbun

Illinois Department of Agriculture
801 Sangamon Avenue
P.O. Box 19281
Springfield, IL 62794-9281
Phone: (217) 785-8300
E-mail: doug.rathbun@illinois.gov

Doug Raymond

Raymond Regulatory Resources/NAA
5857 Trumbull Road
Geneva, OH 44041
Phone: (440) 474-4999
E-mail: djraymond@reg-resources.com

Derek Regal

Tesoro Companies, Inc.
19100 Ridgewood Parkway
San Antonio, TX 78259
Phone: (210) 626-7317
E-mail: derek.b.regal@tsocorPhone.com

Rebecca Richardson

MARC IV Consulting
2005 Tin Cup Road
Mahomet, IL 61853
Phone: (217) 419-3543
E-mail: RRichardson@marciv.com

Ralph Richter

NIST, Office of Weights and Measures
100 Bureau Drive, MS 2600
Gaithersburg, MD 20899-2600
Phone: (301) 975-3997
E-mail: ralph.richter@nist.gov

Bill Ripka

Thermo Fisher Scientific
501 90th Avenue, NW
Minneapolis, MN 55433
Phone: (800) 445-3503
E-mail: bill.ripka@thermofisher.com

Mike Roach

VeriFone
4011 Barwood Court
Tampa, FL 33624
Phone: (813) 205-0876
E-mail: mike_r4@verifone.com

Elisa Robertson

National Conference on Weights
and Measures, Inc
1135 M Street, Suite 110
Lincoln, NE 68508
Phone: (402) 434-4872
E-mail: elisa.robertson@ncwm.net

Lou Sakin

Towns of Hopkinton/Northbridge
1 Ford Lane
Framingham, MA 01701
Phone: (508) 620-1148
E-mail: louissakin@aol.com

Hector Santini

Motorola Solutions
9733 Fredericksburg Road
Tampa, FL 33635
Phone: (813) 220-9174
E-mail: hector.santini@motorolasolutions.com

Attendees – 2013 Final Report

Brett Saum

San Luis Obispo County Weights and Measures
2156 Sierra Way, Suite A
San Luis Obispo, CA 93401-4556
Phone: (805) 781-5922
E-mail: bsaum@co.slo.ca.us

Dale Saunders

VDACS – Office of Weights and Measures
P.O. Box 1163
Richmond, VA 23218
Phone: (804) 786-2476
E-mail: dale.saunders@vdacs.virginia.gov

Prentiss Searles

American Petroleum Institute
1220 L Street, NW
Washington, DC 20005
Phone: (202) 682-8227
E-mail: searlesp@api.org

David Sefcik

NIST, Office of Weights and Measures
100 Bureau Drive, MS 2600
Gaithersburg, MD 20899-2600
Phone: (301) 975-4868
E-mail: david.sefcik@nist.gov

Joseph Silvestro

Retired
Gloucester Co. New Jersey
64 Forage Drive
Mickleton, NJ 08056
Phone: (856) 423-5360
E-mail: silver7777@comcast.net

Scott Simmons

Colorado Oil and Public Safety
633 17th Street, Suite 500
Denver, CO 80202
Phone: (303) 378-1103
E-mail: scott.simmons@state.co.us

Daniel Smith

Alaska Division of Measurement Standards/CVE
11900 Industry Way, Bldg. M, Suite 2
Anchorage, AK 99515
Phone: (907) 365-1210
E-mail: dan.smith1@alaska.gov

Bill Spitzley

Michigan Department of Agriculture
and Rural Development
940 Venture Lane
Williamston, MI 48895-2451
Phone: 517-655-8202
E-mail: spitzleyW@michigan.gov

Josh Stepanian

Pennsylvania Department of Agriculture
Bureau of Weights and Measures
2301 North Cameron Street
Harrisburg, PA 17110
Phone: (717) 787-9089
E-mail: jstepanian@pa.gov

Brad Stotler

NATSO, Representing America's
Travel Plazas and Truckstops
1737 King Street, Suite 200
Alexandria, VA 22314
Phone: (202) 309-0400
E-mail: bstotler@natso.com

Lou Straub

Fairbanks Scales, Inc.
3056 Irwin Drive S.E-mail
Southport, NC 28461
Phone: (910) 253-3250
E-mail: lstraub@fairbanks.com

Larry Stump

Indiana State Department of Health
2525 N. Shadeland Avenue, #03
Indianapolis, IN 46219-1791
Phone: (317) 356-7078
E-mail: lstump@isdh.in.gov

Richard (Dick) Suiter

Richard Suiter Consulting
9819 Anchor Bend
McCordsville, IN 46055
Phone: (317) 336-9819
E-mail: Rsuit700@aol.com

Bob Susor

Mettler-Toledo
1900 Polaris Parkway
Columbus, OH 43240
Phone: (614) 638-1162
E-mail: bob.susor@mt.com

Bill Tedder

North Carolina Department of Agriculture
1050 Mail Service Center
Raleigh, NC 27699-1050
Phone: (919) 733-3313
E-mail: lbtedder@intrstar.net

Stan Toy

Santa Clara County
Weights and Measures
1553 Berger Drive, Building 1, 2nd Floor
San Jose, CA 95112
Phone: (408) 918-4633
E-mail: stan.toy@aem.sccgov.org

Ron Travis

Travis Scale Company
61 West Tucker Road
Liberal, KS 67901
Phone: (620) 626-5940
E-mail: ron@travisscale.com

Beth Treseder

API
1220 L Street, NW
Washington, DC 20005
Phone: (202) 682-8172
E-mail: tresedere@api.org

Jim Truex

National Conference on Weights
and Measures, Inc.
1135 M Street, Suite 110
Lincoln, NE 68508
Phone: (740) 919-4350
E-mail: jim.truex@ncwm.net

Rich Tucker

RL Tucker Consulting, LLC
605 Bittersweet Lane
Ossian, IN 46777
Phone: (260) 622-4243
E-mail: rtucker83@comcast.net

Tim Tyson

Kansas Department of Agriculture
Weights and Measures Division
P.O. Box 19282
Forbes Field Building 282
Topeka, KS 66619-0282
Phone: (785) 862-2415
E-mail: tim.tyson@kda.ks.gov

Rob Underwood

Petroleum Marketers Association of America
1901 N Fort Myer Drive, Suite 500
Arlington, VA 22209
Phone: (703) 351-8000
E-mail: runderwood@pmaa.org

Rob Upright

Vishay Transducers
42 Countryside Road
North Grafton, MA 01536
Phone: (508) 615-1185
E-mail: rob.upright@vishaypg.com

Craig VanBuren

Michigan Department of Agriculture
and Rural Development
940 Venture Lane
Williamston, MI 48895-2451
Phone: (517) 655-8202
E-mail: vanburenc9@michigan.gov

Gilles Vinet

Measurement Canada
151 Tunney's Pasture Driveway
Ottawa, ON K1A 0C9
Phone: (613) 941-8918
E-mail: gilles.vinet@ic.gc.ca

Jack Walsh

Town of Wellesley
525 Washington Street
Town Hall Wellesley
Wellesley, MA 02482
Phone: (774) 279-2559
E-mail: JackBWalsh@verizon.net

Lisa Warfield

NIST, Office of Weights and Measures
100 Bureau Drive, MS 2600
Gaithersburg, MD 20899-2600
Phone: (301) 975-3308
E-mail: lisa.warfield@nist.gov

Joe Warren

Transcore
2441 Adams Drive
Lindenhurst, IL 60046
Phone: (214) 460-4178
E-mail: joe.warren@transcore.com

Attendees – 2013 Final Report

Chester Watson

Kentucky Department of Agriculture
107 Corporate Drive
Frankfort, KY 40601

Phone: (502) 573-0282

E-mail: chester.watson@ky.gov

Richard Whiting

America Wood Fibers
9841 Broken Land Parkway, #302
Columbia, MD 21046

Phone: (410) 290-8700

E-mail: rwhiting@awf.com

Bob Williams

Tennessee Department of Agriculture
P.O. Box 40627
Melrose Station
Nashville, TN 37204-0627

Phone: (615) 837-5109

E-mail: robert.g.williams@tn.gov

Curt Williams

CP Williams Energy Consulting, LLC
95 Roundtree Court
Stockbridge, GA 30281

Phone: (770) 957-6992

E-mail: curtiswilliams@aol.com

Juana Williams

NIST, Office of Weights and Measures
100 Bureau Drive, MS 2600
Gaithersburg, MD 20899-2600

Phone: (301) 975-3989

E-mail: juana.williams@nist.gov

Craig Wilson

Florida Department of Transportation
2740 Centerview Drive
Tallahassee, FL 32301

Phone: (850) 251-6025

E-mail: craig.wilson@dot.state.fl.us

Jane Zulkiewicz

Town of Barnstable
200 Main Street
Hyannis, MA 02601

Phone: (505) 862-4773

E-mail: jane.zulkiewicz@town.barnstable.ma.us