

NIST Office of Weights and Measures (OWM) Analysis Laws and Regulations (L&R) 2024 NCWM Interim Meeting Agenda

The NIST OWM Analysis is submitted to assist the Weights and Measures community as it deliberates on items before the Conference. NIST OWM offers these comments and recommendations based on information and input available as of the date of this report. This does not address information received after this date.

Language shown in a boldface print by ~~striking-out~~ information to be deleted and underlining information to be added.

Assessment of items contained within this report is as the date of this report and does not address information received after this date.

For additional information or assistance please contact a NIST OWM Technical Advisor:

Lisa Warfield, L&R Committee, lisa.warfield@nist.gov or (301) 975-3308
John McGuire, L&R Committee, john.t.mcguire@nist.gov or (202) 981-1750

Subject Series List

| | |
|---|------------|
| Handbook 130 – General | GEN Series |
| Uniform Laws | |
| Uniform Weights and Measures Law | WAM Series |
| Uniform Weighmaster Law | WML Series |
| Uniform Fuels and Automotive Lubricants Inspection Law | FLL Series |
| Uniform Regulations | |
| Uniform Packaging and Labeling Regulation | PAL Series |
| Uniform Regulation for the Method of Sale of Commodities | MOS Series |
| Uniform Unit Pricing Regulation | UPR Series |
| Uniform Regulation for the Voluntary Registration of Servicepersons and Service Agencies for Commercial Weighing and Measuring Devices | RSA Series |
| Uniform Regulation for National Type Evaluation | NTP Series |
| Uniform Fuels and Automotive Lubricants Regulation | FLR Series |
| Uniform E-Commerce Regulation | ECM Series |
| Examination Procedure for Price Verification | PPV Series |
| NCWM Policy, Interpretations, and Guidelines | POL Series |
| Handbook 133 | NET Series |
| Other Items | OTH Series |

Table of Contents

| | |
|--|-----------|
| Subject Series List | 1 |
| PAL – Uniform Packaging and Labeling Regulation | 5 |
| PAL-24.1 Section 10.11. <i>Cannabis</i> and <i>Cannabis</i> -Containing Products..... | 5 |
| NIST OWM Executive Summary for PAL-24.1 – Section 10.11. <i>Cannabis</i> and <i>Cannabis</i> -Containing Products..... | 6 |
| MOS – Uniform Regulation for the Method of Sale of Commodities | 10 |
| MOS-24.2 Section 2.16.3.1. Tare Weights, Part (c) Allowable difference. | 10 |
| NIST OWM Executive Summary for MOS-24.2 – Section 2.16.3.1. Tare Weights, (c) Allowable difference | 12 |
| MOS-24.3 Section 2.16.3.1. Tare Weights, Part (d) Average requirement | 16 |
| NIST OWM Executive Summary for MOS-24.3 – Section 2.16.3.1. Tare Weights, (d) Average Requirement | 17 |
| MOS-24.4 Section 2.16.3.1. Tare Weights, (e) Tare Determination..... | 20 |
| NIST OWM Executive Summary for MOS-24.4 – Section 2.16.3.1. Tare Weights, (e) Tare Determination..... | 20 |
| RSA – Uniform Regulation for the Voluntary Registration of Service Persons and Service Agencies for Commercial Weighing and Measuring Devices | 23 |
| RSA-24.1 Section 4. Voluntary Registration | 23 |
| NIST OWM Executive Summary for RSA-24.1 – Section 4. Voluntary Registration..... | 24 |
| FLR – Uniform Fuels and Automotive Lubricants Regulation | 28 |
| FLR-23.3 D Section 2.20. Hydrogen Fuel..... | 28 |
| NIST OWM Executive Summary for FLR-23.3 – Section 2.20. Hydrogen Fuel – | 28 |
| NET – Handbook 133: Checking the Net Content of Packaged Goods | 32 |
| NET-22.1 A Section 1.2.6. Deviations Caused by Moisture Loss or Gain and Section 2.3.8. Table 2-3 Moisture Allowances..... | 32 |
| NIST OWM Executive Summary for NET-22.1 – Section 1.2.6. Deviations Caused by Moisture Loss or Gain and Section 2.3.8. Table 2-3 Moisture Allowances..... | 33 |
| NET-24.1 Section 3.11. Ice Cream Novelties. | 43 |
| NIST OWM Executive Summary for NET-24.1 – Section 3.11. Ice Cream Novelties | 46 |
| NET-24.2 Section 4.9. Procedure for Checking the Contents of Specific Agriculture Seed Packages Labeled by Count., and Appendix D. AOSA Rules for Testing Seeds. | 62 |
| NIST OWM Executive Summary for NET-24.2 – Section 4.9. Procedure for Checking the Contents of Specific Agriculture Seed Packages Labeled by Count., and Appendix D. AOSA Rules for Testing Seeds. | 67 |
| OTH – Other Items | 70 |
| OTH-24.1 X. Uniform Shipping Law | 70 |

NIST OWM Executive Summary for OTH-24.1 – X, Uniform Shipping Law70

OTH-07.1 D Fuels and Lubricants Subcommittee77

OTH-11.1 D Packaging and Labeling Subcommittee79

Item Block 1 (B1) Renewable Diesel and Diesel79

B1: MOS-23.1 A Sections 2.31. Biodiesel and biodiesel Blends that Contain Greater Than or Equal to 21 % by Volume Biodiesel. and 2.40. Diesel Fuel.79

B1: FLR-23.1 A Sections 1.9. Biodiesel Blend., 1.27. Fuel Oil., 1.XX. Renewable Diesel., 3.3.2. Automotive Fuel Rating., 3.15. Biodiesel and Biodiesel Blends Containing Greater than 20 % by Volume Biodiesel.79

NIST OWM Executive Summary for Item Block 1 (B1) –Renewable Diesel and Diesel80

Item Block 2 (B2) Reference ASTM Standards D8080 and D848789

B2: MOS-24.1 Section 2.9. Liquefied Natural Gas (LNG) Vehicle Fuel, 2.10. Compressed Natural Gas (CNG)., and 2.XX. Compressed Natural Gas (CNG) Blended with Hydrogen..89

B2: FLR-24.1 Section 3.11.2.1.X. Identification of Grade. and 3.12.2.X. Identification of Grade.89

NIST OWM Executive Summary for Item Block 2 (B2) –Reference ASTM Standards D8080 and D848790

References:93

Appendix A. Supporting Documents93

Table 1. Reporting Structure

| |
|---|
| Source: Name and affiliation of the submitter. |
| Submitter’s Purpose and Justification: The submitter’s concise statement as to the intent or purpose of this proposal. The justification describes the national importance, and background on the issue, and may contain references to supporting data or documents. The justification may be summarized by NIST OWM. |
| NIST OWM Executive Summary: High-level points that summarize the Technical Aspects of the item and recommendations pertaining to the Item Under Consideration. |
| Table 2. Summary of Recommendations. |
| Item Under Consideration – The latest language that the Committee has moved forward as the Item membership is considering. NIST OWM has applied the appropriate formatting according to NIST Handbooks |
| NIST OWM Detailed Technical Analysis – A detailed analysis with background information and recommendations from the NIST Office of Weights and Measures (OWM) |
| Summary of Discussions and Actions – A NIST OWM summary of details and discussion on this Item. This includes discussion and decisions of the Standing Committee. This may also include information from sectors, trade associations, task groups, and subcommittees. |
| Regional Association Reporting – An NIST OWM Summarization of the Regional Association Meeting finalized reports. <ul style="list-style-type: none"> • Each region will be identified by its regional acronym along with the year and meeting. • The meetings within each region will be in chronological order. |
| Found at the end of the Report: References: Appendix A: Supporting Documents |

Details of All Items
(in order by Item Number)

PAL – Uniform Packaging and Labeling Regulation

PAL-24.1 Section 10.11. Cannabis and Cannabis-Containing Products.

Source: Doctors for Cannabis Regulation

Submitter’s Purpose and Justification:

Provide states with a universal symbol to clearly identify products containing intoxicating cannabinoids. At present, there are several symbols being used which is an issue right now with multistate *Cannabis* license holders who are required to have different packaging in each jurisdiction. NCWM providing a symbol that states can adopt as they see fit can begin to harmonize under one symbol, which will avoid major headaches in the event of federal legalization.















Uniform product identity is crucial to continue establishing consumer trust and equity in each transaction. We believe it’s important that consumers understand whether a product they are buying contains intoxicating cannabinoids.

There are currently 14 different symbols being used in the US, none of which comply with ISO/ANSI standards for warning symbols (table below). The U.S. needs a pathway to uniform intoxicating product identification to solve multistate operator cost of compliance and provide a pathway for a future of interstate commerce.

ASTM International Technical Committee D37 on Cannabis has developed D8441/D8441M Standard Specification for an International Symbol for Identifying Consumer Products Containing Intoxicating Cannabinoids (IICPS), which defines specifications for a harmonized graphical symbol that can be used as a means of identifying consumer products containing intoxicating cannabinoids. The symbol is available without having to pay for the ASTM standard by visiting <https://www.dfc.org/universal-cannabis-symbol> or the websites of state agencies who have already adopted it, which are Montana, Vermont, South Dakota, and New Jersey.

Multi-state operators currently have different symbol requirements, with compliance cost and hassle involved in having to use different symbols in different states. Providing the industry with the option of adopting a symbol based on a consensus standard positions NCWM to become the natural answer to a future of interstate commerce, likely after future federal legalization, making the NIST Handbook 130 the ideal home for reference to a universal symbol that provides states the option to adopt at their own discretion at any pace they like, before or after any federal legalization.

NIST OWM Analysis
2024 NCWM Interim L&R Agenda Items

| Symbol design | Authorities having jurisdiction (AHJs) using the symbol | Shape of outline (conventional meaning) | Emphasized color (conventional meaning) | Number of colors (including white) | Graphical element (cannabis leaf) | Large graphical element for the visually impaired | Text excluded from interior of symbol | ISO & ANSI compliant |
|---|---|---|---|------------------------------------|-----------------------------------|---|---------------------------------------|----------------------|
|  | ICPS: MT, NJ, SD, & VT | Triangle (warning) | Yellow (caution) | 2 | Yes | Yes | Yes | Yes |
|  | AR | None | None | 2 | No | No | No | No |
|  | AZ, CO, FL, & OH | Diamond (none) | Red (prohibition) | 2 | No | No | No | No |
|  | CA | Triangle (warning) | None | 2 | Yes | No | No | No |
|  | CT, MA, ME, & RI | Triangle (warning) | Red (prohibition) | 3 | Yes | Yes | Yes | No |
|  | MD | Triangle (warning) | Red (prohibition) | 2 | Yes | No | No | No |
|  | MI | Inverted triangle (none) | Green (safe condition) | 2 | Yes | Yes | No | No |
|  | NM | Diamond (none) | Red (prohibition) | 2 | No | No | No | No |
|  | NV | Triangle (warning) | None | 2 | No | No | No | No |
|  | NY | Square (none) | Yellow, red (caution, prohibition) | 4 | Yes | No | No | No |
|  | OK | Rectangle (none) | Red (prohibition) | 3 | Yes | No | No | No |
|  | OR | Rectangle (none) | Red (prohibition) | 3 | Yes | Yes | No | No |
|  | WA | Diamond (none) | Yellow, green (caution, safe condition) | 4 | Yes | Yes | No | No |
|  | Canada | Octagon (stop) | Red (prohibition) | 3 | Yes | Yes | No | No |

The submitter pointed out the following possible arguments and responses.

NCWM doesn't measure intoxicating cannabinoids, so we shouldn't have to label it. We think this is not unlike the recently passed regulations requiring "*Cannabis*" to appear on the PDP. Here, we're going further with product identification.

The CTG just passed product identification standards. Why this now? The *Cannabis* industry is dynamic and travels faster than the recently approved standards that were originally submitted years ago.

This will conflict with the symbol selected by my state. States have discretion on adoption. Passing this standard allows for maximum flexibility for states to adopt it when they are ready.

The submitter requested Voting status in 2024.

| NIST OWM Executive Summary for PAL-24.1 – Section 10.11. Cannabis and Cannabis-Containing Products | |
|--|--|
| NIST OWM Recommendation: OWM recommends this item be Withdrawn. | |
| <ul style="list-style-type: none"> This proposal is a warning statement rather than a quantity statement. If this becomes a requirement within NIST Handbook 130, Section 10.1.2(a)(3) it will violate the existing UPLR Section 8.1 General. | |

- Health issues should be regulated by the state or local health department or cannabis commission, and/or FTC or the FDA when cannabis becomes legally recognized by the federal government.
 - Proposals with pictograms have been rejected by NCWM because they are not enforceable.
 - In the item under consideration the word “percent” or the symbol “%” should be used for uniformity throughout the document.
 - If this item proceeds forward in NCWM, it should be assigned to the NCWM Cannabis Task Group.
-
- ¹ In contrast to hemp, marijuana remains a Schedule I substance under the Controlled Substances Act. NIST does not have a policy role related to the legalization of the production, sale, distribution, or use of cannabis (including hemp and marijuana). NIST participates in the National Conference of Weights and Measures (NCWM) as part of NIST’s statutory mission to promote uniformity in state laws, regulations, and testing procedures.

**Table 2. Summary of Recommendations
PAL-24.1 – Section 10.11. Cannabis and Cannabis-Containing Products**

| | Status Recommendation | Note* | Comments |
|-----------|-----------------------|-------|----------|
| Submitter | Voting | | |
| OWM | Withdrawn | | |
| WWMA | Assigned | | |
| NEWMA | Assigned | | |
| SWMA | Informational | 1 | |
| CWMA | Voting | | |
| NCWM | | | |

***Notes Key:**

- 1 Submitted modified language
- 2 Item not discussed
- 3 No meeting held
- 4 Not submitted on agenda
- 5 No recommendation or not considered

Item under Consideration:

(NIST OWM has applied the appropriate formatting according to NIST Handbooks)

Amend Handbook 130 Uniform Packaging and Labeling Regulation as follows:

10.11. Cannabis and Cannabis-Containing Products *(See Section 10.11. NOTE)*

10.11.1. Definition. – *Cannabis* is a genus of flowering plants in the family Cannabaceae, of which *Cannabis sativa*, *indica*, *ruderalis* are species., and any hybridization thereof. This definition includes products that contain 0.3 percent or less of Total Delta-9 Tetrahydrocannabinol (THC)

(also known as Hemp) and products that contain more than 0.3 percent of Total Delta-9 THC (also known as *cannabis*, marijuana, or marihuana).

10.11.2. Labeling. – Any *Cannabis* or *Cannabis*-containing products intended for human or animal consumption or application, shall bear on the outside of the package the following:

(a) On the principal display panel

- (1) The statement “Contains *Cannabis*.” The word “*Cannabis*” shall be capitalized and italicized;
- (2) The statement “Contains 0.3 % or less Total Delta-9 THC” or “Contains more than 0.3 % Total Delta-9 THC”; and
- (3) Shall display a *Cannabis* Leaf symbol in accordance with the latest version of ASTM D8441/D8441M Standard Specification for an International Symbol for Identifying Consumer Products Containing Intoxicating Cannabinoids. (Amended 20XX)**

NIST OWM Detailed Technical Analysis:

Health warning (which this is) should be regulated by the state or local health department or cannabis commission, and/or FTC or the FDA when cannabis becomes legally recognized by the federal government.

NIST OWM believes this item violates the regulations in NIST Handbook 130, Uniform Packaging and Labeling Regulation (UPLR)

Section 8. Prominence and Placement: Consumer Packages

8.1. General. – All information required to appear on a consumer package shall appear thereon in the English language and shall be prominent, definite, plain, and conspicuous as to size and style of letters and numbers and as to color of letters and numbers in contrast to color of background. Any required information that is either in hand lettering or hand script shall be entirely clear and equal to printing in legibility.

Nowhere in the UPLR does it allow for symbols or pictograms to be regulated on packages. The NCWM has rejected these proposals in the past as they are not enforceable.

Summary of Discussions and Actions

Regional Association Reporting:

Western Weights and Measures Association

At the 2023 WWMA Annual Meeting, Vince Wolpert (Co-Chair Cannabis TG) stated there will be changes to the last portion of the statement for products containing intoxicating cannabinoids. Recommends item remains assigned to the Cannabis Task Group.

Steven Harrington (Oregon) recommended withdrawal after testimony was heard from several other regulators.

Matt Douglas (California Department of Agriculture, Division of Measurement Standards) had a general inquiry as to whether this is an identity symbol or a warning symbol. Matt encouraged the submitter work with the Cannabis TG to determine if this is the appropriate place for this item, and recommended this item be assigned to the Cannabis TG.

Kurt Floren (Los Angeles County, California) stated they were opposed to this item. Kurt supports cannabis quantity statements, however, does not feel we should be providing warning, as once we step in to regulate warnings, it becomes regular for us to have to do so. Kurt stated that the health issues are better left to health agencies, and when the federal government moves toward legalization, the FDA and FTC can get involved.

Jose Arriaga (Orange County, California) is in favor of having a harmonizing symbol to identify cannabis, however, does not support cautionary statements, including the word intoxicating.

Joe Moreo (Trinity County, California) stated this should include an identification, a warning, and a potency, since the federal government defines hemp, THC, and cannabis by potency. Recommended the item be assigned to the Cannabis TG.

The WWMA recommends this item be Assigned to the Cannabis TG.

Central Weights and Measures Association

At the 2023 CWMA Interim Meeting, Mike Harrington (Iowa) commented that this item does not pertain specifically to their state but believes it will be federally legalized so supports the standards moving forward. Mike further commented that states who do not have legal use of cannabis should still be involved in helping develop the standard once it is legalized federally. Chris Guay (CGGT) concurs and believes having consistency across states is important to establish a benchmark developed by NCWM. Steve Peter (representing himself) concurs and supports the item moving forward. The Committee agrees this item is developed and ready for voting status.

Southern Weights and Measures Association

At the 2023 SWMA Annual Meeting, it was recognized that the current item under consideration could be interpreted to apply to all *Cannabis*-containing products and the SWMA recommends the following change to clarify that this requirement does not apply to hemp. SWMA recommends the following language for 10.11.2.(a)3. to move forward as Informational to allow for further vetting of the item.

- 3. If the product contains more than 0.3 % Total Delta-9 THC it shall display a Cannabis Leaf symbol in accordance with the latest version of ASTM D8441/D8441M Standard Specification for an International Symbol for Identifying Consumer Products Containing Intoxicating Cannabinoids.**

Northeastern Weights and Measures Association

At the 2023 NEWMA Interim Meeting, Lou Sakin (Holliston, Massachusetts and representing the Cannabis Task Group) stated this is an attempt to standardize (nationwide) a warning symbol on product containing cannabis. Lou believes the item is ready for voting and related that the WWMA recommended

it remain as Assigned and that some members feel this is not a weights and measures issue. Many states have different symbols.

Jason Flint (New Jersey) stated they already adopt the symbols and wording. ASTM already uses this labeling and Jason is in favor of Assigned but would vote yes for it. Jim Willis (New York) and Walter Remmert (Pennsylvania) remarked they are not in favor of this item as a Voting item and should stay Assigned. Jim Cassidy (Massachusetts) and Marc Paquette (Vermont) agreed it should stay Assigned.

NEWMA recommended this Item be Assigned.

MOS – Uniform Regulation for the Method of Sale of Commodities

MOS-24.2 Section 2.16.3.1. Tare Weights, Part (c) Allowable difference.

Source: National Propane Gas Association

Submitters Purpose and Justification:

Resolve the discrepancy that exists between NIST Handbook 130 and Title 49 of the Code of Federal Regulations with respect to the allowable differences between the stamped tare weight and the actual tare weight of cylinders used for compressed or liquefied gases in refillable cylinders.

The data presented in NIST Special Publication, “NIST SP 2200-01, 2022 NCWM-NIST National Survey on 20 lb LPG (Propane) Cylinders,” is sufficient evidence that the tolerances imposed in Handbook 130 on the marking of tare weights for propane cylinders are not in sync with the real world. For example, the report states that “*nearly half (44.3 %) of new cylinders and significantly less (32.0 % of used cylinders were in compliance with existing tare weight requirements,*” (in reference to the current Handbook 130 requirements). Which means, of course that the great majority of cylinders, even new cylinders, were not in compliance. The reasons for that include the following:

- As quoted from the report, “*Initial assessments suggest that cylinder manufactures use a tolerance of 1 %, which is primarily based on Measurement Canada’s requirement of 1 %.*” If a cylinder’s tare weight can vary $\pm 1\%$ from stamped value as manufactured, a cylinder’s actual tare weight cannot be expected to be within $\pm 0.5\%$ of the marked value after the cylinder at any point in time thereafter.
- For practical reasons, some manufacturers may use a statistical method to arrive at an average tare weight based on previous measurements of a sufficiently large sample pool. Whatever variance there may be in the actual weight of the cylinder versus the marked tare weight, the fact is that over 98 % of the new cylinders weighed were in compliance with the DOT tolerances.
- The following statement from the report is very telling: “*It is highly unusual and irregular to see a tolerance where a very significant majority of the packages are in compliance (in this case, 98.4 %).*” The report goes on to state that 34.3 % of “used” cylinders would not be in compliance with the DOT tolerances. These two statements call attention to the fact that these grill cylinders are in constant circulation, subject to a wide variety of conditions, treatment and possible abuse by potentially many different customers, thereby underlining the need to steer clear of overburdensome and unwarranted regulation.

- Scales utilized in most retail locations where cylinders are filled are beam scales which do not have the capability of weighing cylinders to the sensitivity or number of decimal places necessary to verify the initial tare weight while a cylinder is under vacuum using Handbook 130 requirements. Additionally, there is no requirement in any national code or standard to fill cylinders by weight at the point of sale when the cylinder is transported for non-commercial use. These cylinders are not considered to be transported “in commerce” and are therefore not required to be filled by weight, thereby allowing for the determination of maximum fill level using the fixed maximum liquid level gauge. Scales are not required to be installed at these facilities.
- Even when the product is released to the atmosphere to “empty” the cylinder, there will always be some amount of liquid and vapor remaining in the cylinder, unless the cylinder has been put under vacuum. The liquid, of course, is much denser than air and the vapor in the cylinder is 1.5 times the weight of the air that was in the sample cylinders when they were weighed to establish the “average” tare weights.
- A minus tolerance of – 3 % will not result in extreme loss to the propane marketer in most cases, because the overfilling prevention device (OPD) will activate and prevent the overfilling of the cylinder in the vast majority of cases. As stated in the report, only 1.1 % of all cylinders tested exceeded the legal filling limit. Considering the time of year that this project was undertaken and in some northern states, it is very likely that some of those cylinders may have been filled volumetrically when the temperature was below 40 °F, it would not be unusual that more product was put into the cylinder because the OPD is calibrated to the maximum fill at 40 °F and the liquid density increases as the temperature gets colder.
- The price for a pound of propane as stated in the report seems high, as it would equate to \$5.51 per gallon (4.24 lbs. per gallon). The Department of Energy published the average cost of propane in 2022 and it was shown to be \$2.23 per gallon.

Opposing arguments may take the following form:

- “The purpose of NIST Handbook 130 is to ensure that the customer gets what he pays for and that the propane marketer doesn’t lose out, either.” The rebuttal to this argument from the standpoint of the customer is provided in the justification in number 18 above. From the marketer’s standpoint, the fact that the vast majority of retail gallons sold in the U.S. are sold by National Propane Gas Association members and that those very members endorsed this proposal is evidence that marketers are not concerned about the small quantities of gas that may not be billed to the customer.
- “We should make DOT change their tolerances instead of NCWM changing theirs.” The fact is that NCWM allowable differences are so unreasonable that 56 % of newly manufactured cylinders were not in compliance with them. That should be reason enough to realize that NCWM needs to change. In addition, once gas is put into a cylinder, there will always be a little bit of liquid remaining in the cylinder unless it is vacuum purged or opened to the atmosphere. This means that accurately measuring the tare weight of a cylinder becomes very difficult unless specific procedures are followed to ensure that the cylinder is truly “empty.”

The submitter requested that this be a voting item in 2024 and a retroactive requirement, enforceable to all devices.

NIST OWM Executive Summary for MOS-24.2 – Section 2.16.3.1. Tare Weights, (c) Allowable difference

NIST OWM Recommendation: OWM recommends a status of Informational to allow DOT PHMSA to respond to the NCWM petition (dtd. January 2023).

NOTE: The Committee should consider blocking Items MOS-24.2, MOS-24.3, and MOS-24.4 if they remain on the L&R Agenda. Each of these Items are modifications to subsections c, d, and e in Section 2.16.3.1.

- NCWM petitioned the Department of Transportation – PHMSA requesting they reevaluate the allowable differences and they consider existing NIST Handbook 130 tolerances and data provided within the SP 2200-01, 2022 NCWM-NIST National Survey on 20 lb LPG (Propane) Cylinders.

- Once the Committee reviews the response from DOT and if this item moves forward the language for 2.16.3.1.(c) should appear as:

(c) **Allowable difference.** – If the stamped or stenciled tare is used to determine the net contents of the cylinder, the allowable difference between the actual tare weight and the stamped (or stenciled) tare weight, or the tare weight on a tag attached to the cylinder ~~for a new or used cylinder, shall be within:~~

(1) For cylinders manufactured prior to December 28, 2022 shall be within:

- ~~(1)i.~~ $\frac{1}{2}$ % for tare weights of 9 kg (20 lb) or less; or
- ~~(2)ii.~~ $\frac{1}{4}$ % for tare weights of more than 9 kg (20 lb).

(2) For cylinders manufactured on or after December 28, 2022 shall be within the following limits prescribed by General requirements for specification cylinders, 49 C.F.R. § 178.35:

- i. **For a cylinder of 25 lbs or less at the time of manufacture, a lower tolerance of 3 % and an upper tolerance of 1 %; or**
- ii. **For a cylinder exceeding 25 lbs at the time of manufacture, a lower tolerance of 2 % and an upper tolerance of 1 %.**

NOTE: Failure of a cylinder tare weight to be within the required allowable difference is considered a Method of Sale violation. The cylinder shall be removed from use until the tare weight is corrected.

Table 2. Summary of Recommendations
MOS-24.2 – Section 2.16.3.1. Tare Weights, (c) Allowable difference

| | Status Recommendation | Note* | Comments |
|-----------|-----------------------|-------|----------|
| Submitter | Voting | | |
| OWM | Informational | 1 | |
| WWMA | Informational | | |
| NEWMA | Withdraw | | |
| SWMA | Informational | 1 | |
| CWMA | Informational | | |
| NCWM | | | |

***Notes Key:**

- 1 Submitted modified language
- 2 Item not discussed
- 3 No meeting held
- 4 Not submitted on agenda
- 5 No recommendation or not considered

Item under Consideration:

Amend the Uniform Regulation for the Method of Sale of Commodities as follows:

2.16.3.1. Tare weights.

...

(c) **Allowable difference.** – If the stamped or stenciled tare is used to determine the net contents of the cylinder, the allowable difference between the actual tare weight and the stamped (or stenciled) tare weight, or the tare weight on a tag attached to the cylinder for a new or used cylinder, shall be within **the following limits prescribed by 49 CFR § 178.35:**

- (1) ~~$\frac{1}{2}$ % for tare weights of 9 kg (20 lb) or less~~ **For a cylinder of 25 pounds or less at the time of manufacture, a lower tolerance of 3 percent and an upper tolerance of 1 percent;**
or
- (2) ~~$\frac{1}{4}$ % for tare weights of more than 9 kg (20 lb)~~ **For a cylinder exceeding 25 pounds at the time of manufacture, a lower tolerance of 2 percent and an upper tolerance of 1 percent.**

NOTE: Failure of a cylinder tare weight to be within the required allowable difference is considered a Method of Sale violation. The cylinder shall be removed from use until the tare weight is corrected.

NIST OWM Detailed Technical Analysis:

This proposal seeks to align NIST Handbook 130, Uniform Regulation for the Method of Sale of Commodities, Section 2.16.3.1.(c) with General Requirements for Specification Cylinders, **49 CFR §**

178.35 released on December 28, 2020, which applies to cylinders manufactured after December 28, 2022.

The new DOT general requirements regarding the accuracy of the tare weight stamped on a cylinder, preempt the requirements found currently in NIST Handbook 130. OWM notes the DOT requirement only applies to cylinders manufactured AFTER December 28, 2022. The manufactured date can be verified by inspecting the collar on the cylinder to which the required date is stamped.

We concur that 2.16.3.1.(c) needs to be updated to reflect new DOT requirements, the new language must reflect how the new DOT and Handbook 130 tolerance would apply. OWM recommends that a note be included in the language that states:

- (c) **Allowable difference.** – If the stamped or stenciled tare is used to determine the net contents of the cylinder, the allowable difference between the actual tare weight and the stamped (or stenciled) tare weight, or the tare weight on a tag attached to the cylinder ~~for a new or used cylinder, shall be within:~~

(1) For cylinders manufactured prior to December 28, 2022 shall be within:

- ~~(1)~~ **i.** 1/2 % for tare weights of 9 kg (20 lb) or less; or
~~(2)~~ **ii.** 1/4 % for tare weights of more than 9 kg (20 lb).

(2) For cylinders manufactured on or after December 28, 2022 shall be within the following limits prescribed by General requirements for specification cylinders, 49 C.F.R. § 178.35:

- i. For a cylinder of 25 lbs or less at the time of manufacture, a lower tolerance of 3 % and an upper tolerance of 1 %; or**
ii. For a cylinder exceeding 25 lbs at the time of manufacture, a lower tolerance of 2 % and an upper tolerance of 1 %.

NOTE: Failure of a cylinder tare weight to be within the required allowable difference is considered a Method of Sale violation. The cylinder shall be removed from use until the tare weight is corrected.

The Compressed Gas Association (CGA) is an organization of primarily cylinder manufacturers and qualifiers who petitioned the DOT in 2009, and recommended tolerances with no supporting data, which DOT adopted in 2022.

NCWM petition (dtd. January 2023) requesting DOT PHMSA reevaluate the allowable differences and that DOT take into account existing NIST Handbook 130 tolerances and data provided within the **SP2200-01, 2022 NCWM NIST National Survey on 20 lb LPG (Propane) Cylinders.**

OWM concurs with NCWM in that the DOT tolerances are too stringent and only considers the safety aspects of testing and not potential economic harm. As documented in the NCWM – NIST National Survey, it is estimated that under the new DOT requirements, there is a potential loss of 10 million dollars to consumers and 30 million dollars to consumers. High tolerances may also affect manufacturers' ability to accurately fill net contents. During DOT rulemaking, they were unaware that HB 130 regulations

existed. The proposed rule was never intended to change an existing tare weight standard, but to create one.

The survey results found that 55.7 % of 9,482 new cylinders tested were not within the HB130 tolerances of ± 0.5 % and that 68 % of the 1,535 used cylinders tested were not in compliance. Though on the surface it may appear that the ± 0.5 % may be too stringent, initial assessments suggest that cylinder manufacturers use a tolerance of 1 % which is based on Measurement Canada's requirement. This would lead to a higher failure rate.

OWM believes that DOT will provide a formal response to the NCWM petition by the end of 2023. OWM is recommending that this item remain Informational to allow the Committee time to receive and review the response from DOT.

Summary of Discussions and Actions

Regional Association Reporting:

Western Weights and Measures Association

At the 2023 WWMA Annual Meeting, John McGuire (NIST OOWM) wanted to bring to the attention of the Committee that NCWM petitioned the U.S. DOT to look at the tolerances and should hold off until an answer is provided by the U.S. DOT. John McGuire anticipates the response to be sent to the NCWM when complete.

Matt Douglas (California Department of Food and Agriculture, Division of Measurement Standards) recommended withdrawal, and felt that the cylinders should be stamped with an accurate tare statement, as the U.S. DOT allowable difference of the stamped tare weight versus the actual tare weight is a safety item. Matt stated that the NCWM requirements are for consumer protection, and are within the U.S. DOT safe ranges, so there is no conflict.

Steven Harrington (Oregon) takes no position, however, asked that the Committee consider adding metric units back to the proposal.

The WWMA recommends this item be Informational.

Central Weights and Measures Association

At the 2023 CWMA Interim Meeting, no comments were heard. Because of no comments, the Committee recommends this item be Informational.

Southern Weights and Measures Association

At the 2023 SWMA Annual Meeting, based on comments received during open hearings and the fact the National Conference on Weights and Measures sent a petition to DOT to evaluate tolerances on tare, the SWMA recommends this item be informational awaiting response from DOT.

The Committee would like to acknowledge the language recommended by OWM for 2.16.3.1.(c) and as shown below:

- (c) **Allowable difference.** – If the stamped or stenciled tare is used to determine the net contents of the cylinder, the allowable difference between the actual tare weight and the stamped (or stenciled) tare weight, or the tare weight on a tag attached to the cylinder ~~for a new or used cylinder, shall be within:~~

(1) For cylinders manufactured prior to December 28, 2022 shall be within:

- ~~(1)~~**i.** 1/2 % for tare weights of 9 kg (20 lb) or less; or
- ~~(2)~~**ii.** 1/4 % for tare weights of more than 9 kg (20 lb).

(2) For cylinders manufactured on or after December 28, 2022 shall be within the following limits prescribed by General requirements for specification cylinders, 49 C.F.R. § 178.35:

- i. For a cylinder of 25 lbs or less at the time of manufacture, a lower tolerance of 3 % and an upper tolerance of 1 %; or**
- ii. For a cylinder exceeding 25 lbs at the time of manufacture, a lower tolerance of 2 % and an upper tolerance of 1 %.**

NOTE: Failure of a cylinder tare weight to be within the required allowable difference is considered a Method of Sale violation. The cylinder shall be removed from use until the tare weight is corrected.

Northeastern Weights and Measures Association

At the 2023 NEWMA Interim Meeting, Steven Timar (New York) is concerned that this adversely affects the existing tolerances (increase) and could be a safety issue if the tank is overfilled (relying on the blow off valve).

Jason Flint (New Jersey) agreed with New York on this issue. This item shouldn't move forward without receiving response from U.S. DOT concerning their position on the item.

Cheryl Ayer (New Hampshire) agreed with New York and New Jersey. Walter Remmert (Pennsylvania) and Lou Sakin (Holliston, Massachusetts) believe it should be Withdrawn.

MOS-24.3 Section 2.16.3.1. Tare Weights, Part ~~(d)~~ Average requirement.

Source: National Propane Gas Association

Submitters Purpose and Justification:

Remove an ambiguous and subjective requirement that is based on a statistical approach not clearly defined.

Deleting (d) is necessary because the requirement itself is too subjective and not based on a clear compliance threshold. For example, there is no clear indication what “predominantly” means. There is no

direction on how many cylinders to test or what statistical methods to employ in determining the meaning of “predominantly.”

An opposing argument may be that the paragraph is needed in order to protect consumers from fraud due to a scheme undertaken by sellers or retail propane and the manufacturers of cylinders. The rebuttal to that argument is that in effect, this rule in Handbook 130 is skewed against retail sellers of propane and by its very nature alleges that there is collusion between cylinder manufacturers and retail propane marketers. Such an argument does not take into consideration the variances in raw materials, the tolerances that manufacturers can achieve, or any number of factors that address the very usefulness of a tare weight marking in the modern world of filling a cylinder with liquefied petroleum gas.

The submitter requested that this be a voting item in 2024 and a retroactive requirement, enforceable to all devices.

| NIST OWM Executive Summary for MOS-24.3 – Section 2.16.3.1. Tare Weights, (d) Average Requirement |
|--|
| <p>NIST OWM Recommendation: OWM recommends this item be Withdrawn.</p> <p>NOTE: The Committee should consider blocking Items MOS-24.2, MOS-24.3, and MOS-24.4 if they remain on the L&R Agenda. Each of these Items are modifications to subsections c, d, and e in Section 2.16.3.1.</p> <ul style="list-style-type: none">• This proposal seeks to remove the Average Requirement from NIST HB 130, Method of Sale Regulation for compressed or liquified gases in refillable cylinders in Section 2.16.3.1.(d).• This safeguard has been in place in NIST HB 130, Method of Sale Regulation since 1990. The proposal was developed in conjunction with the Compressed Gas Association (CGA).• The “Average Requirement” is essential to ensuring the net quantity of contents in packaged goods and is designed to avoid complaints from consumers and competitors who believe the seller misrepresented the net quantity of the product.• OWM and NCWM believe this an important safeguard. NCWM cited this in their petition (dtd. Jan. 2023) to DOT requesting they amend Hazardous Materials: Miscellaneous Amendments Pertaining to DOT Specification Cylinders 49 C.F.R. § 178.35.• Predominance is indicated in NIST Handbook 44 1.10 General Code G-UR.4.1 <p>G-UR.4. Maintenance Requirements.</p> <p>G-UR.4.1. Maintenance of Equipment. – All equipment in service and all mechanisms and devices attached thereto or used in connection therewith shall be continuously maintained in proper operating condition throughout the period of such service. Equipment</p> |

in service at a single place of business shall not be considered “maintained in a proper operating condition” if:

- (a) predominantly, equipment of all types or applications are found to be in error in a direction favorable to the device user; or
- (b) predominantly, equipment of the same type or application is found to be in error in a direction favorable to the device user.

**Table 2. Summary of Recommendations
 MOS-24.3 – Section 2.16.3.1. Tare Weights, (d) Average Requirement**

| | Status Recommendation | Note* | Comments |
|-----------|-----------------------|-------|----------|
| Submitter | Voting | | |
| OWM | Withdrawn | | |
| WWMA | Withdrawn | | |
| NEWMA | Withdrawn | | |
| SWMA | Withdrawn | | |
| CWMA | Informational | | |
| NCWM | | | |

***Notes Key:**

- 1 Submitted modified language
- 2 Item not discussed
- 3 No meeting held
- 4 Not submitted on agenda
- 5 No recommendation or not considered

Item Under Consideration:

Amend the Uniform Regulation for the Method of Sale of Commodities as follows:

2.16.3.1. Tare weights.

...

~~(d) Average requirement.—When used to determine the net contents of cylinders, the stamped or stenciled tare weights of cylinders at a single place of business found to be in error predominantly in a direction favorable to the seller and near the allowable difference limit shall be considered to be not in conformance with these requirements.~~

NIST OWM Detailed Technical Analysis:

This proposal seeks to remove the Average Requirement from NIST HB 130, Method of Sale Regulation for compressed or liquified gases in refillable cylinders in Section 2.16.3.1.(d).

This safeguard has been in place in NIST HB 130, Method of Sale Regulation since 1990. The proposal was developed in conjunction with the Compressed Gas Association (CGA).

The “Average Requirement” is essential to ensuring the net quantity of contents in packaged goods and is designed to avoid complaints from consumers and competitors who believe the seller misrepresented the net quantity of the product. The average requirement helps ensure cylinder manufacturers do not stamp a Tare Weight (TW) that is within the allowable difference but is also consistently favorable to their business. Commercial transactions with the absence of an average requirement could create an unfair competition and may be potentially abused, either intentional or unintentionally.

OWM and NCWM believe this an important safeguard. NCWM cited this in their petition (dtd. Jan. 2023) to DOT requesting they amend Hazardous Materials: Miscellaneous Amendments Pertaining to DOT Specification Cylinders 49 C.F.R. § 178.35. The NCWM petition states, *“we request DOT also consider adding an “Average Requirement” to its tare regulations in future editions of the Federal regulations as it is anticipated to improve measurement accuracy and production controls when large plus and minus tolerances in specifications are allowed. This would be consistent with what is currently in the NIST Handbook 130 Uniform Method of Sale Regulation of Commodities. It ensures the businesses are not using the allowable differences to gain a competitive advantage by imposing an “average requirement” on the variations. Below is the current language in NIST Handbook 130 that is recommended for adoption by DOT.”*

The NCWM recommendation to DOT for the inclusion of an “average requirement” to tare regulations was requested because it improves measurement accuracy and production controls when large \pm tolerances in specifications are allowed. This ensures the businesses are not using the allowable differences to gain a competitive advantage by imposing an “average requirement” on the variations.

The average requirement states that “when used to determine the net contents of cylinders, the stamped or stenciled tare weights of cylinders at a single place of business found to be in error predominantly in a direction favorable to the seller and near the allowable difference limit shall be considered to be not in conformance with these requirements.” In NIST Handbook 44, predominance is defined in General Code, UR.4.1. Maintenance of Equipment when used in application of a weighing or measuring device.

Summary of Discussions and Actions

Regional Association Reporting:

Western Weights and Measures Association

At the 2023 WWMA Annual Meeting, John McGuire (NIST OWM) stated that this proposal seeks to remove the average requirements from the Method of Sale. These requirements have been in place since 1990 and were developed in conjunction with the Compressed Gas Association and was designed with the intent of avoiding complaints from consumers that sellers were misrepresenting the net quantity.

Matt Douglas (California Department of Food and Agriculture, Division of Measurement Standards) stated that the need for consumer protection exceeds the justification of this item and recommends withdrawal.

The WWMA recommends this item be Withdrawn.

Central Weights and Measures Association

At the 2023 NCWM Interim Meeting, no comments were heard. Because no comments, the Committee recommends this be Informational.

Southern Weights and Measures Association

The SWMA does not see any merit in this item and recommends the item be Withdrawn.

Northeastern Weights and Measures Association

Jason Flint (New Jersey), Jim Willis (New York), Jimmy Cassidy (Massachusetts), and Cheryl Ayer (New Hampshire) all believe the item has no merit and feels it should be Withdrawn.

NEWMA recommend this Item be Withdrawn.

MOS-24.4 Section 2.16.3.1. Tare Weights, (e) Tare Determination.

Source: National Propane Gas Association

Submitter’s Purpose and Justification:

The modification proposed to (e) is necessary because this text is confusing. Sometimes the protective cap for a cylinder is attached by a plastic lanyard to the valve and is not easily removed. Other times, it is removeable. Sometimes the “label” is actually a sleeve and it must be removed prior to filling the cylinder. Other times it is adhered to the cylinder and cannot be removed easily.

An opposing argument may be that the paragraph is needed in order to protect consumers from fraud due to a scheme undertaken by sellers or retail propane and the manufacturers of cylinders. The rebuttal to that argument is that in effect, this rule in Handbook 130 is skewed against retail sellers of propane and by its very nature alleges that there is collusion between cylinder manufacturers and retail propane marketers. Such an argument does not take into consideration the variances in raw materials, the tolerances that manufacturers can achieve, or any number of factors that address the very usefulness of a tare weight marking in the modern world of filling a cylinder with liquefied petroleum gas.

The submitter requested that this be a voting item in 2024 and a retroactive requirement, enforceable to all devices.

| |
|--|
| NIST OWM Executive Summary for MOS-24.4 – Section 2.16.3.1. Tare Weights, (e) Tare Determination |
| NIST OWM Recommendation: OWM recommends this item be Withdrawn. |
| NOTE: The Committee should consider blocking Items MOS-24.2, MOS-24.3, and MOS-24.4 if they remain on the L&R Agenda. Each of these Items are modifications to subsections c, d, and e in Section 2.16.3.1. |

- This Item refers to when the “removable protective cap and label” are not included as part of the stamped or stenciled tare, and whether it “should” or “must” be included in the total tare determination.
- The Method of Sale Regulation clearly states that accurate tare is needed to properly determine net contents verification. If the protective cap and label are not included in the stamped tare weight on the cylinder it must be included in the total tare weight determination when a net contents verification test is performed.
- Industry practice has been not to include the protective cap and label as part of the stamped tare, because they are considered “removable”.

**Table 2. Summary of Recommendations
 MOS-24.4 – Section 2.16.3.1. Tare Weights, (e) Tare Determination**

| | Status Recommendation | Note* | Comments |
|-----------|-----------------------|-------|----------|
| Submitter | Voting | | |
| OWM | Withdrawn | | |
| WWMA | Withdrawn | | |
| NEWMA | Withdrawn | | |
| SWMA | Withdrawn | | |
| CWMA | Informational | | |
| NCWM | | | |

***Notes Key:**

- 1 Submitted modified language
- 2 Item not discussed
- 3 No meeting held
- 4 Not submitted on agenda
- 5 No recommendation or not considered

Item Under Consideration:

Amend the Uniform Regulation for the Method of Sale of Commodities as follows:

2.16.3.1. Tare weights.

...

(e) Tare Determination. – The stamped or stenciled tare weight shall be used for purposes of verifying the net contents unless the actual tare weight is determined, then the actual tare weight shall be used for purposes of net content verification. The removable protective cap and label are not included in the stamped or stenciled tare but ~~must~~ can be included in the total tare determinations.

NIST OWM Detailed Technical Analysis:

This proposal has to do with when the “removable protective cap and label” are not included as part of the stamped or stenciled tare, and whether it “should” or “must” be included in the total tare determination.

The method of sale clearly indicates that accurate tare is needed to properly determine net contents verification. If the protective cap and label are not included in the stamped tare weight on the cylinder it must be included in the total tare weight determination when a net contents verification test is performed. Industry practice has been not to include the protective cap and label as part of the stamped tare, because they are considered “removable”.

Determining accurate tare is a normal and familiar process among weights and measures officials. For these reasons OWM recommends that this item be Withdrawn.

Summary of Discussions and Actions

Regional Association Reporting:

Western Weights and Measures Association

At the 2023 WWMA Annual Meeting, Matt Douglas (California Department of Food and Agriculture, Division of Measurement Standards) recommended Withdrawal, as the cap and label have to be considered as either tare, or as part of the product, which is unacceptable.

John McGuire (NIST OWM) concurred with Matt Douglas and stated that NIST OWM believes the Method of Sale Regulation states that an accurate tare must be stated to determine the net contents declaration.

Kurt Floren (Los Angeles County, California) agreed with the previous testimony, and that changing “must” to “can” was absurd, as it makes more non-uniformity with no benefit.

The WWMA recommends this item be Withdrawn.

Central Weights and Measures Association

At the 2023 CWMA Interim Meeting, no comments were heard. Because of no comments, the Committee recommends this item be Informational.

Southern Weights and Measures Association

The SWMA does not see any merit in this item and recommends the item be Withdrawn.

Northeastern Weights and Measures Association

Jason Flint (New Jersey), Jim Willis (New York), Jimmy Cassidy (Massachusetts), and Cheryl Ayer (New Hampshire) all believe the item has no merit and feels it should be Withdrawn.

NEWMA recommend this Item be Withdrawn.

RSA – Uniform Regulation for the Voluntary Registration of Service Persons and Service Agencies for Commercial Weighing and Measuring Devices

RSA-24.1 Section 4. Voluntary Registration

Source: Arkansas Bureau of Standards

Submitter’s Purpose and Justification:

Add the requirement that a Service Agent or individuals employed by a Service Agency must possess certificates demonstrating basic competency in applying applicable Handbook 44, 130, and 112 requirements.

Mandating an assessment of an individual’s knowledge, on weighing and measuring devices, will verify competency and serve as a tool to increase consistency of services offered to owner/operators. This process is inconsistently accomplished, nationwide, throughout jurisdictions.

The addition of this wording was not possible until the recent creation of Registered Service Agent Testing through the National Conference on Weights and Measures (NCWM). By placing the testing and certificates, into a single location(s), jurisdictions will not have to individually implement core knowledge assessment. Note, this DOES NOT restrict jurisdictions from implementing additional testing, which can also be added through NCWM. Centralization of core knowledge testing creates a uniform knowledge assessment that benefits NCWM membership and owner/operators. This knowledge base would then be consistent across the country and membership could change as needed through the Professional Development Committee.

Adoption of this language also serves to guarantee that certificates could be accepted in all jurisdictions, benefitting Service Agents. Core or specific competency requirements could be achieved for multiple jurisdictions at one location or in a shorter time. Alternative proctoring compounds this savings even more by allowing testing almost anywhere. Each of these steps will cut cost and time investment of onboarding. This new testing will give Service Agent’s a “one-stop shopping” option in demonstrating knowledge and gaining registration in multiple jurisdictions.

The submitter presented the following potential arguments with responses:

Associated Cost – Testing through NCWM will cause a financial burden.

NCWM has set forth to make the testing reasonably affordable. Associated cost for multi-state travel, missed work, technician pay, and others should offset testing cost.

Using the wording “certificate(s) granted by a standards development organization recognized by the Director”.

Though NCWM is the only organization to currently have this option available, it is not the intent to preclude certificates from any other organization that may be recognized or those created by jurisdictions. Including only “NCWM certificates” could be seen as limiting the options available in the future.

Immediately being enforceable

Submitter would defer to jurisdictional authority on implementation. Reasonable effort should be given to educate and train Service Agents as to the requirement and location of the testing. Creating effective dates or changing requirements on applications should create reasonable accommodations to the industry. Centralized testing will create an even greater advantage, as Service Agents will only have to accomplish the action once.

Difficulty in ability to attain certificate.

This may be an unintended consequence that presents itself with opportunity. Inability to pass the test will create an opportunity of jurisdictions to better educate and train those individuals. In turn this creates a better Service Agent and provides more consistent and correct service to owner/operators.

Lack of training by Service Agents

Another consequence that may present opportunity. This could create a marketplace for training. Whether this is taken up by individual, jurisdictions, industry, or NCWM it could become the catalyst for increasing education and provide higher quality service.

Lack of mandatory testing for Inspectors

Some service companies may take issue with no policy providing for mandated inspector/investigator testing. The model law does not have an inspector provision; therefore, it cannot be amended. Jurisdictions should have training and accountability programs in place to ensure inspector/investigator knowledge. Professional certification through NCWM does not serve as core competency for inspectors/investigators, rather it provides “confidence that an individual has a strong understanding of U.S. weights and measures standards as adopted by NCWM and published in Handbooks 44, 130, and 133” (NCWM website).

Service Agent testing is meant to only establish core competency in reading of the handbooks and being able to use the appropriate material when inspecting and testing devices. The certificates issued will NOT be considered “Professional Certification”.

Recourse is available by submitting a Form 15 with any proposed changes or creation of model law to include inspector/investigator requirements. Service Agents can go through the exact same process and be heard.

The submitter requested Voting status for 2024.

| NIST OWM Executive Summary for RSA-24.1 – Section 4. Voluntary Registration |
|---|
| <p>NIST OWM Recommendation: OWM recommends a status of Informational.</p> <ul style="list-style-type: none">• This agenda item changes the individualized State training, certification, and experience factors from the sole discretion of the Director and allowing another Standards development organization to become another qualifying entity for Registered Service Agents. This is not an inhibitor; rather it is an additional resource that needs to be fully vetted. |

- Directors need to fully vet the standards organization to ensure proper qualifications are being met.
- What are the minimum criteria and which organizations?
- Will each standards organization meet the same quality of training and testing of the Directors program?
- Currently, 30 States adopt the RSA with an addition 15 States having a law or regulation in force but not based on NCMW standard.

**Table 2. Summary of Recommendations
RSA-24.1 – Section 4. Voluntary Registration**

| | Status Recommendation | Note* | Comments |
|-----------|-----------------------|-------|----------|
| Submitter | Voting | | |
| OWM | Informational | | |
| WWMA | Informational | 1 | |
| NEWMA | Developing | | |
| SWMA | Voting | 1 | |
| CWMA | Informational | | |
| NCWM | | | |

***Notes Key:**

- 1 Submitted modified language
- 2 Item not discussed
- 3 No meeting held
- 4 Not submitted on agenda
- 5 No recommendation or not considered

Item Under Consideration:

Amend Handbook 130 Uniform Regulation for the Voluntary Registration of Service Persons and Service Agencies for Commercial Weighing and Measuring Devices as follows:

Section 4. Voluntary Registration

An individual or agency qualified by, **training or experience, and certificate(s) granted by a standards development organization recognized by the Director;** may apply for registration to service weighing devices or measuring devices on an application form supplied by the Director. Said form, duly signed and witnessed, shall include ~~certification~~ **guarantee** by the applicant that the individual or agency is fully qualified to install, service, repair, or recondition whatever devices for the service of which competence is being registered; has in possession or available for use, and will use, all necessary testing equipment and standards; and has full knowledge of all appropriate weights and measures laws, orders, rules, ~~and~~ regulations, **and policies.** An ~~applicant~~ **individual or each individual of an agency also** shall submit appropriate **certificate(s), evidence, ~~or~~ and references as to qualifications.** **The certificate(s) shall apply to the types of weighing devices and measuring**

devices inspected and tested by the individual or agency. Device types without available certificate(s) may be exempted. Application for registration shall be voluntary, but the Director is authorized to reject or limit any application.

(Added 1966) (Amended 1984 **and 20XX**)

NIST OWM Detailed Technical Analysis:

This agenda item changes the individualized State Registered Service Agents training and experience factors from the sole discretion of the Director to include a standards development organization(s) to become another qualifying entity. This is not an inhibitor; rather it is an additional resource that needs to be fully vetted.

This will allow the examination and certification process to be administered through a different standard setting organization(s) at the discretion of the Director. The NCWM is in the process of building a complex examination process to help the states with qualified Registered Service Agents. This process needs to be discussed and fully understood by State Directors to ensure compatibility within their programs.

Summary of Discussions and Actions

Regional Association Reporting:

Western Weights and Measures Association

At the 2023 WWMA Annual Meeting, Steven Harrington (Oregon) is not opposed to this item, and that it seems the proposal is trying to take the NCWM exams and build them into model regulations for RSAs. Steven Harrington is struggling with line 16 on page L&R-108 of the WWMA Agenda, did not want a standards development organization to decide for the states, and that it should be the Director's discretion.

Kevin Schnepf (California Department of Food and Agriculture, Division of Measurement Standards) agreed with the previous statements, adding "and/or" to line 16.

Aaron Yanker (Colorado Department of Agriculture, Weights and Measures) echoed the previous statements, and appreciated the direction for consistency.

The modified language containing suggestions from Steven Harrington and Kevin Schnepf is below.

An individual or agency ~~qualified by training or experience~~ may apply for registration to service weighing devices or measuring devices on an application form supplied by the Director, **who may consider training and/or experience, and certificate(s) granted by a standards development organization recognized by the Director;** Said form, duly signed and witnessed, shall include **certification guarantee** by the applicant that the individual or agency is fully qualified to install, service, repair, or recondition whatever devices for the service of which competence is being registered; has in possession or available for use, and will use, all necessary testing equipment and standards; and has full knowledge of all appropriate weights and measures laws, orders, rules, ~~and~~ regulations, **and policies.** An ~~applicant~~ **individual or each individual of an agency** ~~also~~ shall submit appropriate **certificate(s), evidence, or and references as to qualifications.** **The certificate(s) shall apply to the types of weighing devices and measuring devices inspected and tested by the**

individual or agency. Device types without available certificate(s) may be exempted. Application for registration shall be voluntary, but the Director is authorized to reject or limit any application.

(Added 1966) (Amended 1984 **and 20XX**)

The WWMA recommends this item be Informational.

Central Weights and Measures Association

At the 2023 CWMA Interim Meeting, no comments were heard. The Committee recommends this item be made informational and needs more input. The Committee also questions the definition of “guarantee” by the applicant. The word “verification” may be better suited. This is found in Section 4 Voluntary Registration

Southern Weights and Measures Association

At the 2023 SWMA Annual Meeting, based on comments received during open hearings, the SWMA recommends this as a Voting item with the following language for Section 4:

An individual or agency qualified by, **training or experience, and certificate(s) granted by a standards development organization recognized by the Director;** may apply for registration to service weighing devices or measuring devices on an application form supplied by the Director. Said form, duly signed and witnessed, shall include **certification guarantee acknowledgment** by the applicant that the individual or agency is fully qualified to install, service, repair, or recondition whatever devices for the service of which competence is being registered; has in possession or available for use, and will use, all necessary testing equipment and standards; and has full knowledge of all appropriate weights and measures laws, orders, rules, and regulations, ~~and policies~~. An ~~applicant~~ **individual or each individual of an agency also** shall submit appropriate **certificate(s), evidence, or and references as to qualifications.** **The certificate(s) shall apply to the types of weighing devices and measuring devices inspected and tested by the individual or agency.** **Device types without available certificate(s) may be exempted.**

Application for registration shall be voluntary, but the Director is authorized to reject or limit any application.

(Added 1966) (Amended 1984 **and 20XX**)

Northeastern Weights and Measures Association

At the 2023 NEWMA Interim Meeting, Lou Sakin (Holliston, Massachusetts) does not register service agents and never will. Jim Cassidy (Massachusetts) remarked weights and measures officials are already in place for these inspections and this would be a conflict of interest.

Jim Willis (New York) and Marc Paquette (Vermont) do not allow registered service companies. Ethan Bogren (Westchester, New York) recommends that its fully developed it should be Voting.

NEWMA recommends this be a Developing Item.

FLR – Uniform Fuels and Automotive Lubricants Regulation

FLR-23.3 D Section 2.20. Hydrogen Fuel.

Source: Quong and Associates

Submitter’s Purpose and Justification:

Add equivalent hydrogen quality standard, ISO 14687 to 2.20.

As hydrogen fuel cell vehicles expand worldwide, the codes and standards that support them have also moved to an international stage. Currently, most of the hydrogen quality requirements for fuel cell vehicles have occurred under the International Organization for Standardization (ISO) 14687 “Hydrogen fuel quality – Product specification”. The latest revision of ISO 14687 occurred in 2019, and SAE 2719 was updated in 2020 to match. The attached document compares the latest hydrogen fuel quality specifications in ISO 14687 2019 and SAE J2719 2020. Having both requirements will allow the user of the station to use the most updated specification and ensure that fuel cell vehicles are protected from contaminated fuel.

Some may argue that Argument: The updates in ISO 14687 could be considered a relaxation of the hydrogen quality requirements. The submitter explained that the changes were made to provide flexibility for contaminants which could not damage the fuel cell vehicle, or combine contaminants with similar characteristics, such as inert gases or carbon monoxide/ formaldehyde/formic acid.

The submitter requested that this be a Voting Item.

| NIST OWM Executive Summary for FLR-23.3 – Section 2.20. Hydrogen Fuel |
|--|
| <p>NIST OWM Recommendation: OWM recommends this item be returned to the submitter for additional development to address the questions and concerns raised at the Conference.</p> <ul style="list-style-type: none">• The weights and measures community recognizes for more than two decades a concerted effort in the hydrogen community to globally align related standards.• Address the concerns raised about the proposal resulting in dual fuel quality standards in effect should there be a delay in the alignment process. What are the mechanisms in place for rapid alignment of the standards and the technical committee with oversight having the ability to recognize emerging test methods for the verification of constituent values?• There should be clarification on whether specific portions of the ISO standard applicable to fueling road vehicles must be cited in the fuel specification requirement. What guidance is offered for that interim period when the SAE and ISO standards differ or what would occur if as a result of the standard review cycle if the hydrogen community is left with differing contaminant specifications where the standards cannot be aligned? |

**Table 2. Summary of Recommendations
FLR-23.3 – Section 2.20. Hydrogen Fuel**

| | Status Recommendation | Note* | Comments |
|-----------|-----------------------|-------|--|
| Submitter | Voting | | |
| OWM | Developing | | |
| WWMA | Withdrawn | | |
| NEWMA | Developing | | |
| SWMA | Developing | | Request that the submitter have a developed item by 2024 NCWM Interim. If not recommend it be Withdrawn. |
| CWMA | Developing | | |
| NCWM | | | |

***Notes Key:**

- 1 Submitted modified language
- 2 Item not discussed
- 3 No meeting held
- 4 Not submitted on agenda
- 5 No recommendation or not considered

Item Under Consideration:

Amend Handbook 130 Uniform Fuels and Automotive Lubricants Regulation as follows:

2.20 Hydrogen Fuel. – Shall meet the latest version of SAE J2719, “Hydrogen Fuel Quality for Fuel Cell Vehicles” or ISO 14687 “Hydrogen fuel quality — Product specification”.

(Added 2012) (Amended 20XX)

NIST OWM Detailed Technical Analysis:

The weights and measures community recognizes a more than two decades a concerted effort in the hydrogen community to globally align related standards. Concerns have been raised about the proposal resulting in dual fuel quality standards in effect should there be a delay in the alignment process. Clarification needs to be sought on the mechanisms in place for rapid alignment of the standards and the technical committee with oversight having the ability to recognize emerging test methods for the verification of constituent values. NIST OWM notes that there should also be clarification on whether specific portions of the ISO standard applicable to fueling road vehicles must be cited in the fuel specification requirement.

The NIST sponsored USNWG on Developing Commercial Measurements Standards for Hydrogen Gas was established in 2007; however, the Work Group’s membership level has declined as a result of the normal progression of changes that have occurred in both the public and private sectors and there has been very limited recent activity to address hydrogen gas legal metrology requirements. Juana Williams has not had the opportunity to discuss the proposals as they appear in NCWM Publication 16 (2023) with FALS Chair Benchea. NIST OWM has participated in the National Hydrogen Fuel Cell Codes and Standards Coordinating Committee (NHFCCSCC) several of whose members have been part of the Work Group and that group also represents a wide variety of stakeholders (to include the submitter) in the

hydrogen community. Juana Williams has made this group, which works to harmonize global hydrogen standards, aware of the 2023 NIST HB 130 proposals and continues to update the NHFCCSCC on the latest status of all proposals and provide them with contact information should they wish to provide input to the weights and measures community as it prepares for the 2023 NCWM Annual Meeting.

Address the concerns raised about the proposal resulting in dual fuel quality standards in effect should there be a delay in the alignment process. Is there typically a chronological order adhered to in the development of these standards which would eliminate any concerns about dual fuel standards being in effect at the same time? What are the mechanisms in place for rapid alignment of the standards and the technical committee with oversight having the ability to recognize emerging test methods for the verification of constituent values? What guidance is offered for that interim period when the SAE and ISO standards differ or what would occur if as a result of the standard review cycle if the hydrogen community is left with differing contaminant specifications where the standards cannot be aligned?

NIST OWM is aware of the submitter's May 8, 2023 letter recommending further modification to the proposal to specify the ISO Grade (D) and the application of the most recently published standard; however, there would be a gap in compliance typically when a standard becomes more stringent.

Summary of Discussions and Actions:

At the 2023 NCWM Interim Meeting, Matthew Curran (Florida) opposed this item due to two different standards reflected within one regulation. FALS Chair Benchea reported that the two standards would be confusing, and FALS recommends additional outreach to stakeholders and make this Item Informational (Refer to agenda item OTH-07.1–Fuels and Lubricants Subcommittee). Many regulators spoke in support of the FALS recommendation. Spencer Quong agreed to do additional work to address the concerns that were raised. Austin Sheppard (County of San Diego) concurred with the previous comments regarding two standards and suggests picking the more stringent of the two standards.

The Committee recommended this as a Developing item and requested Spencer Quong provide an update to the Committee as soon as possible.

Regional Association Reporting:

Western Weights and Measures Association

At the 2022 WWMA, Kevin Schnepf (CDFA/DMS) mentioned that the two systems, ISO, and SAE, are not always aligned. They are meant to be aligned but when changes are made those changes may be adopted at different times (example of 6-month gap in 2019). He also mentioned that the reference standards in the ISO are specifically section (d) of 14687, and this should be referenced specifically. He also mentioned that there may not be a need for this item. The Committee suggests the edits below.

2.20. Hydrogen Fuel. – Shall meet the latest version of SAE J2719, “Hydrogen Fuel Quality for Fuel Cell Vehicles” **or ISO14687 Grade (D) “Hydrogen fuel quality – Product specification”.**
(Added 2012) (**Amended 20XX**)

The WWMA L&R Committee recommends Voting status with the above revisions based on the comments heard.

At the 2023 WWMA Annual Meeting, Matt Douglas (California Department of Food and Agriculture, Division of Measurement Standards) supported Information or Developing status for this item, as ISO and SAE are on different update schedules, and may not always align.

The WWMA recommends Withdrawn, as the submitter has not determined which one standard is appropriate, and there are issues having two standards, as stated in the NCWM 2023 Interim report.

Central Weights and Measures Association

At the 2022 CWMA Interim Meeting, Doug Rathbun (Illinois) commented they supported this item and believes it is ready for Voting status. Hearing no further comments during open hearings, the Committee concurs the item is fully developed and ready for Voting status. The Committee recommends the National L&R Committee consider combining this item with FLR-23.4 as a block.

At the 2023 CWMA Annual Meeting, no comments were received and the Committee recommends this as a Developing item.

At the 2023 CWMA Interim Meeting, no comments were heard. The Committee recommends this item remain as Developing until NIST and the developer are ready for it to proceed.

Southern Weights and Measures Association

At the 2022 SWMA Annual Meeting, Matt Curran (Florida) commented that only one reference should be listed if equivalent. Listing both could cause confusion.

Lisa Warfield (NIST OWM) commented that Juana Williams (NIST OWM) is working with the Hydrogen National Work Group and should have an update by January 2023.

The Committee concurred with Dr. Curran that the item needs further development to determine which standard will be referenced and recommends it to be a Developing Item.

At the 2023 SWMA Annual Meeting, they recommend that the submitter provide a modification with the selection of one standard by the 2024 NCWM Interim Meeting or the item be Withdrawn.

Northeastern Weights and Measures Association

At the 2022 NEWMA Interim Meeting, no comments were heard. The Committee does not have a recommendation for this item.

At the 2023 NEWMA Annual Meeting, no comments were heard. The Committee recommended this as a Developing item.

At the 2023 NEWMA Interim Meeting, Lou Sakin (Holliston, Massachusetts) noted that no representative for this item is present to discuss the item. Ethan Bogren (Westchester, New York) believes it should be a Developing item.

NET – Handbook 133: Checking the Net Content of Packaged Goods

NET-22.1 A Section 1.2.6. Deviations Caused by Moisture Loss or Gain and Section 2.3.8. Table 2-3 Moisture Allowances.

Source: NCWM Cannabis Task Group

Submitter's Purpose and Justification:

Establish an acceptable Net Weight allowance for Cannabis, which is related to the MOS Form 15 related to water activity and the Packaging and Labeling Form 15 Sections 2 and 10.

Since *Cannabis* and *Cannabis*-containing products were first legalized by various states, the industry has undergone an unprecedented expansion. Even though these products haven't received Federal approval at this time, more and more states have supported *Cannabis* and *Cannabis*-containing products for medicinal or adult use under their own laws. This has resulted in boutique markets developing across the country with restrictive state boundaries for lack of clarity and uniformity in commercialization of these products.

Cannabis and *Cannabis*-containing products are unique in many aspects; they have a niche as medicine, have resulted in the development of adult use markets, and have an incredible array of different manufacturing and industrial applications. Some of these products contain controlled substances which presents a special concern for the safety and welfare of consumers if misused or mishandled. Further, they are subject to strict regulations by multiple government agencies. *Cannabis* and *Cannabis*-containing products and applications range from non-food to food products for human and animal consumption through inhalation, ingestion, and/or topical or dermal application. They can be used as ingredients in other commodities, changing in most cases the product identity to *Cannabis* products. Some *Cannabis* is very susceptible to environmental conditions easily losing or gaining moisture with consequences impacting net quantity, degradation of active cannabinoids, and/or microbial proliferation depending on the situation. These are just some of the reasons there are many concerns and uncertainty surrounding the moisture allowance of *Cannabis*.

In the retail *Cannabis* trade, insufficient attention and guidance is given to moisture migration in or out of some *Cannabis* packaging and as a result, the contents of some *Cannabis* flower packaging have been found to be underweight, resulting in the patient/consumer paying for weight that they are not receiving. For instance, underweight complaints are the #1 consumer complaint in Oregon. See attached table for data from multiple stores of four brands and the incidence of underweight contents. **Preview:** If you were shopping any one of 3 stores of a popular brand, you'd have a 71 % chance of buying a supposedly 1.75 g package that is 21.6 % underweight, meaning you have a 71 % chance of being ripped off by \$5 (assuming a \$10/g price). The lowest incidence of underweight? 54 %. The lowest percent underweight? 2.75 %.

For the fairness and safety of *Cannabis* consumers, a 3 % ± weight variance based on enforcement of acceptable moisture range needs to be established. A 3 % allowance aligns with other known commodities and with California regulations that outline ± 3 %.

Why 3 %? Consistent with other items in NIST handbook, aligns with California. If the boundaries are too wide, it exposes the program to diversion.

Is underweight really an issue? I filed Public Records requests with every state that allows *Cannabis* flower commerce. Each of them told me they keep no official records on underweight complaints. However, Oregon went on record telling me underweight is one of their largest complaints (attached). As for one other state, see attached data from Colorado that recorded 69 separate container purchases from 18 separate stores within four brands.

The submitter asked that this be a Voting Item in 2022.

NIST OWM Executive Summary for NET-22.1 – Section 1.2.6. Deviations Caused by Moisture Loss or Gain and Section 2.3.8. Table 2-3 Moisture Allowances

NIST OWM Recommendation¹: OWM recommends the item remain assigned to the Cannabis Task Group (TG). However, there are some significant issues need to be addressed before this item is ready for adoption.

- The L&R Committee requested that the NCWM Cannabis TG follow guidance found in NIST Handbook 130, NCWM, Interpretations and Guidelines, Section 2.5.6. “Guidelines for NCWM Resolution of Requests for Recognition of Moisture Loss in Other Packaged Products” to establish the moisture allowances (loss and gain). In 1988, NCWM Task Force developed this Guidelines we encourage the Cannabis Moisture Allowance TG to follow this guidance.
- OWM does not concur with adding a 3 % weight variance without study, documentation, and verification of results.
- A modification to NIST Handbook 133 procedures will need to be submitted for consideration. Current procedures are written to guide inspectors only on applying a moisture allowance when a sample has a negative average error.
- They would need to conduct a nationwide scientifically valid study that reflects regional environment and seasonal changes in humidity. Any studies should also consider the different types of packaging into consideration. This needs to be for both moisture loss and moisture gain (as being proposed). The involvement of industry is crucial for this study.
- Two key components, among others, for any industry in determining moisture loss include:
 1. having “real world” data on product as found in the retail marketing chain (not just laboratory moisture loss data); and
 2. collect data on industry-wide basis (rather than from only one or two companies).
- The 3 % was assigned by the Cannabis TG; the TG based this value on other known commodities stated within NIST HB 133, Table 2-3 Moisture Allowance and to align with California regulations. The Cannabis Moisture Loss WG has not shared any moisture allowance data with the Cannabis TG or L&R Committee.
- OWM recognizes that there was only one member of the Cannabis TG Moisture Loss WG. We encourage other members to join this group, submit data, and reach consensus on bringing language forward to the L&R Committee. OWM recommends that the state directors be surveyed to determine if they intend to have their inspectors take enforcement action on overweight packages of *cannabis*. If they do not implement this type of enforcement action for

| |
|---|
| NIST OWM Executive Summary for NET-22.1 – Section 1.2.6. Deviations Caused by Moisture Loss or Gain and Section 2.3.8. Table 2-3 Moisture Allowances |
| the reason, they doubt that the public or courts would find those cases justify prosecution, then the approach should probably not be added to NIST Handbook 133 and remain as guidance. |
| <p>¹ In contrast to hemp, marijuana remains a Schedule I substance under the Controlled Substances Act. NIST does not have a policy role related to the production, sale, distribution, or use of cannabis (including hemp and marijuana). NIST participates in the National Conference of Weights and Measures (NCWM) as part of NIST’s statutory mission to promote uniformity in state laws, regulations, and testing procedures.</p> |

**Table 2. Summary of Recommendations
NET-22.1 – Section 1.2.6. Deviations Caused by Moisture Loss or Gain and Section 2.3.8. Table 2-3
Moisture Allowances**

| | Status Recommendation | Note* | Comments |
|-----------|-----------------------|-------|----------|
| Submitter | Voting | | |
| OWM | Assigned | | |
| WWMA | Assigned | | |
| NEWMA | Assigned | | |
| SWMA | Assigned | | |
| CWMA | Assigned | | |
| NCWM | | | |

***Notes Key:**

- 1 Submitted modified language
- 2 Item not discussed
- 3 No meeting held
- 4 Not submitted on agenda
- 5 No recommendation or not considered

Item Under Consideration:

1.2.6. Deviations Caused by Moisture Loss or Gain

Deviations from the net quantity of contents caused by the loss or gain of moisture from the package are permitted when they are caused by ordinary and customary exposure to conditions that normally occur in good distribution practice and that unavoidably result in change of weight or measure. According to regulations adopted by the U.S. Environmental Protection Agency, no moisture loss is recognized on pesticides. (See Code of Federal Regulations **40 CFR 156.10.**)

1.2.6.1. Applying a Moisture Allowance

Some packaged products may lose or gain moisture and, therefore, lose or gain weight or volume after packaging. The amount of moisture loss depends upon the nature of the product, the packaging material, the length of time it is in distribution, environmental conditions, and other factors. Moisture loss may occur even when manufacturers follow good distribution practices.

Loss of weight “due to exposure” may include solvent evaporation, not just loss of water. For loss or gain of moisture, the moisture allowances may be applied before or after the package errors are determined.

To apply an allowance before determining package errors, adjust the Nominal Gross Weight (see Section 2.3.6. “Determine Nominal Gross Weight and Package Errors”), so the package errors are increased by an amount equal to the moisture allowance. This approach is used to account for moisture loss in both the average and individual package errors.

It is also permissible to apply the moisture allowances after individual package errors and average errors are determined.

Example:

A sample of a product that could be subject to moisture loss might fail because the average error is minus or the error in several of the sample packages are found to be unreasonable errors (i.e., the package error is greater than the Maximum Allowable Variation (MAV) permitted for the package’s labeled quantity).

You may apply a moisture allowance after determining the package errors by adding the allowance to the Sample Error Limit (SEL) and then, comparing the average error to the SEL to determine compliance. The moisture allowance must be added to the MAV before evaluating sample errors to identify unreasonable minus errors.

(Amended 2010)

This handbook provides “moisture allowances” for some meat and poultry products, flour, pasta, **Cannabis (this only includes plant material but does not include products containing Cannabis)** and dry pet food. (See Chapter 2, Table 2-3. “Moisture Allowances”) These allowances are based on the premise that when the average net weight of a sample is found to be less than the labeled weight, but not by an amount that exceeds the allowable limit, either the lot is declared to be within the moisture allowance or more information must be collected before deciding lot compliance or noncompliance.

Test procedures for flour, some meat, and poultry are based on the concept of a “moisture allowance” also known as a “gray area” or “no decision” area (see Section 2.3.8. “Moisture Allowances”). When the average net weight of a sample is found to be less than the labeled weight, but not more than the boundary of the “gray area,” the lot is said to be in the “gray” or “no decision” area. The gray area is not a tolerance. More information must be collected before lot compliance or noncompliance can be decided. Appropriate enforcement should be taken on packages found short weight and outside of the “moisture allowance” or “gray area.”

(Amended 2002)

Table 2-3. Moisture Allowances

| Verifying the labeled net weight of packages of: | Moisture Allowance is: | Notes |
|--|------------------------|---|
| Flour | 3 % | |
| Dry pet food | 3 % | Dry pet food means all extruded dog and cat foods and baked treats packaged in Kraft paper bags and/or cardboard boxes with a moisture content of 13 % or less at time of pack. |

NIST OWM Analysis
2024 NCWM Interim L&R Agenda Items

| | | |
|--|---------------------------|--|
| Pasta products | 3 % | Pasta products means all macaroni, noodle, and like products packaged in kraft paper bags, paperboard cartons, and/or flexible plastic bags with a moisture content of 13 % or less at the time of pack. |
| Borax | see Section 2.4. Borax | |
| <u>Cannabis</u> | <u>3 %</u> | <u>Cannabis means plant material only, and not products containing Cannabis, whether containing more than 0.3 % Total Delta-9 THC (also known as cannabis, Marijuana, or Marihuana) or containing 0.3 % or less Total Delta-9 THC (also known as Hemp).</u> |
| Wet Tare Only¹ | | |
| Fresh Poultry | 3 % | Fresh poultry is defined as poultry above a temperature of – 3 °C (26 °F) that yields or gives when pushed with the thumb. |
| Franks or hot dogs | 2.5 % | |
| Bacon, fresh sausage, and luncheon meats | 0 % | For packages of bacon, fresh sausage, and luncheon meats, there is no moisture allowance if there is no free-flowing liquid or absorbent material in contact with the product and the package is cleaned of clinging material. Luncheon meats are any cooked sausage product, loaves, jellied products, cured products, and any sliced sandwich-style meat. This does not include whole hams, briskets, roasts, turkeys, or chickens requiring further preparation to be made into ready-to-eat sliced product. When there is no free-flowing liquid inside the package and there are no absorbent materials in contact with the product, Wet Tare and Used Dried Tare are equivalent. |

¹Wet tare procedures must not be used to verify the labeled net weight of packages of meat and poultry packed at an official United States Department of Agriculture (USDA) facility and bearing a USDA seal of inspection. The Food Safety and Inspection Service (FSIS) adopted specific sections of the 2005 4th edition of NIST Handbook 133 by reference in 2008 but not the “Wet Tare” method for determining net weight compliance. FSIS considers the free-flowing liquids in packages of meat and poultry products, including single-ingredient, raw poultry products, to be integral components of these products (see Federal Register, September 9, 2008 [Volume 73, Number 175] [Final Rule – pages 52189-52193]).

NIST OWM Detailed Technical Analysis:

NIST OWM appreciates the work being conducted by Michigan’s lab to determine moisture allowance in Cannabis. OWM continues to encourage the Cannabis TG to follow the NCWM 2022 Interim L&R Committee recommendation which states, “The Committee is recommending the NCWM Cannabis Task Group to follow NIST Handbook 130, NCWM, Interpretations and Guidelines section 2.5.6 Guidelines for NCWM Resolution of Requests for Recognition of Moisture Loss in Other Packaged Products to establish the moisture allowances (loss and gain).” NIST OWM also encourages the Task Group to reach out to the Cannabis Industry for data more “real-world” data and assistance in the determining of both moisture loss and gain, to which no precedent has been set for moisture gain. Then, “when all preliminary information recommended in NIST Handbook 130, NCWM, Interpretations and Guidelines section 2.5.6 Guidelines for NCWM Resolution of Requests for Recognition of Moisture Loss in Other Packaged Products has been collected, a field test of the proposed compliance scheme should be conducted by weights and measures officials to prove its viability”.

The weights and measures laws do not grant the director the authority to establish the moisture content limits for foods, drugs, or cosmetics. OWM recommends that Committee clearly state that weights and measures inspections conducted under this proposed regulation will be limited to only cannabis (the plant)

and that there is no intent to expand to products containing cannabis. This statement of intent early in the consideration process may be helpful to future readers of the historical record.

For the reasons provided OWM does support the development of this proposal. OWM has provided similar guidance in the past for other products based on information from FDA.

Since the 1980's, OWM has worked with NCWM on moisture loss studies beginning with the creation of the NCWM Task Force on Commodity Requirements. The NCWM Task Force developed the Guidelines for NCWM Resolution of Requests for the Recognition of Moisture Loss in Other Packaged Foods (see NIST Handbook, NCWM Policy, Interpretations and Guidelines Section 2.5.6. in VI at 00-20-h130-vi-final-4.pdf) which the NCWM adopted in 1988. Since its adoption, industry who contacts OWM for advice on how moisture allowance is developed is advised to follow the NCWM guidance. In addition, NCWM recognized considerations proposed by industry on moisture allowance. The rice industry and bar soap manufacturers approached OWM for information and were provided this advice. The pet food industry and pasta industries have both followed the NCWM guidance for moisture loss recognition and have been successful with proposal for moisture allowances being adopted by NCWM. In the interest of due process, interest of its own guidelines, and the precedents it has followed for more than 33 years, OWM recommends the Committee advise the cannabis industry to apply the same NCWM guidance. They would need to conduct a nationwide scientifically valid study that reflects regional environment and seasonal changes in humidity. Any studies should also consider the different types of packaging into consideration.

Two key components, among others, for any industry in determining moisture loss include: 1. having “real world” data on product as found in the retail marketing chain (not just laboratory moisture loss data) and 2. collecting data on an industry-wide basis (rather than from only one or two companies).

Supporting data based on nationwide scientifically valid moisture loss and moisture gain studies for packaged cannabis was not submitted with this proposal. Test procedures or limits on moisture loss or gain which are not based on scientifically established data, that occur during current good distribution practices, must be avoided as they likely violated due process (among other cases see especially *Cook Family Foods, Ltd. v. Voss*, 781 F. Supp. 1458 (C.D. Cal. 1991)). OWM is concerned that adding the proposed moisture allowances to NIST Handbook 133 without valid studies will make it difficult for the states to reduce or remove them in the future, if data from field testing or later research, indicates that they were either too large or too small.

This proposal involves limits on moisture loss and moisture gain, and it is likely that two studies will be required. In the past, NCWM focused on moisture loss but with this is an area where limits on moisture gain will be established therefore different test conditions will need to be considered and test protocols developed. Typically, desiccating products regain moisture at a slower rate than they lose moisture, but that rate depends on several variables. A moisture gain study may take longer and be carried out in controlled environmental conditions. Regardless both studies must encompass the typical shelf life of the packaged product. If the studies are not done in a way that is scientifically valid, which represents real world conditions, and reflects the typical packaging and shelf-life of products, they will NOT protect consumers or packers. They will also not ensure inventory or taxes are accurately maintained. In fact, if the proposed limits are too small or too large, they could impose unjustifiably higher costs on packers and those costs will be passed onto consumers.

A modification to NIST Handbook 133 procedures will need to be submitted for consideration. Current procedures are written to guide inspectors only on applying a moisture allowance when a sample has a negative average error.

Enforcement of net weight regulations where a moisture allowance is in question, requires the inspector to obtain additional information on the sample and may involve seizing samples for testing and contacting the packer to obtain production records for review. This is in part as to why they are sometimes treated as tolerances which can facilitate fraudulent packaging practices. If an unscrupulous packer underfills packages 1 % when there is an overly generous 3 % moisture allowance that results in the packer's filling practice not being verified. Typically, officials will invest the time and effort into moisture loss (and here gain) investigations when they receive consumer or competitor complaints. Even more frequently when a reseller believes that a supplier has repeatably shipped them underweight packages. Complaints from business owners will also arise when a particular shipment of expensive products and the complainant suspects, unreasonably underweight packages. Inspectors also pursue these types of investigations if they suspect, based on past testing, that a packer has repeatably delivered underweight packages that fall within a specified moisture allowance.

As noted above, it is important to stress that plus and minus values for moisture allowance are not tolerance limits. Under this moisture allowance approach inspectors will not be able to take enforcement actions as they currently do when using NIST Handbook 133.

Since the 1970s, weights and measures has treated overweight and overfilled packages as being acceptable because overpacking is limited by the packer for economic reasons. Inspectors do not take action on samples when the average error is positive (or when a minus error falls with the Sample Error Limit). Under this proposal inspectors will not be permitted to approve lots with positive average errors that fall within the 3 percent limit (for a 2 g package this 3 percent value = + 60 mg). Inspectors will not remove products from sale for being underweight within the 3 percent limit (- 60 mg) (unless the value is treated as a tolerance), until they take additional steps to find out more about the moisture content of the cannabis by consulting the packer to obtain production records, date of pack and inspection. They will also determine if the packer is following current good manufacturing and distribution practices and then makes a determination that the overfilling or underfilling was reasonable or not. During this stage of the process the packaged goods are placed under a stop-sale-hold order and cannot be removed from the point of inspection until released.

OWM recommends that the state directors be surveyed (see OWM general comments on Block 3) to determine if they intend to have their inspectors take enforcement action on overweight packages of cannabis. If they do not implement this type of enforcement action for the reason, they doubt that the public or courts would find those cases justify prosecution, then the approach should probably not be added to NIST Handbook 133 and remain as guidance.

The importance of limiting moisture gain could be well documented and presented as meriting enforcement action but any arguments would need to be persuasive. Taking enforcement action does occur when overpacking is used as an unfair trade practice (states have taken action against an ice packer who put 10 lb of ice in a bag and then labeled it 8 lb, and then advertises that the 8 lb bag lasts as long as a competitor 10 lb bag).

This proposal raises another question for the Committee is when there are no Maximum Allowable Variations (MAV) for plus package errors. OWM recommends that the Committee study the idea of changing this approach and have the MAV values apply to both positive and negative package errors when packaged cannabis is being tested.

OWM encourages the Committee to consider conducting a broad long-term study in cooperation with the cannabis industry to determine if the 10 percent MAV packages under 36 g is an appropriate for application to cannabis packages.

Cannabis is packaged on modern high precision weighing instruments and variations in packaging fill that occur in current good manufacturing practice are likely to be much less than they were when the 10 percent MAV's for packages under 36 g was established in the early 1970s and at that time the data used was collected at both the point of pack and retail stores and included data for both small packages of foods and other consumer products. (Note: for a 2 g package of cannabis the MAV is 200 mg)

A reference to an acceptable moisture test procedure must be developed included in this proposal. The moisture loss approach in NIST Handbook 133 anticipates that samples may need to be taken and tested if there is a significant enforcement action contemplated. If an inspector repeatably finds minus package errors within the 3 percent limits (for a 2 g package of cannabis this is ± 60 mg) the inspector will collect a sample and compare the moisture content as found along with the moisture content at time of pack information provided by the packer. If there is a dispute the inspector can share a sample with the packer for testing and the two values can be intercompared to ensure the labs are in agreement. This may occur in a situation where the product is consistently found to be underweight, between one to three percent, on lots that were just delivered from the packer or where the inspector suspects someone is packing shortweight and claiming it is moisture loss. Procedures need to be known in advance, so the state metrology laboratory has the necessary test equipment and trained personnel available to perform the test promptly.

In addition, adding a recognized moisture test procedure a detailed set of instructions for selecting and handling the moisture samples will need to be provided. If an inspector seizes samples for testing, they will need to follow good sampling procedures and handling practices to ensure the samples are protected and stored properly prior to and after testing. If there are legal or other restrictions that apply to the seizure, handling, storage, or transportation of cannabis samples then these can be included in the instructions to assist the inspector.

In developing the final proposal, the following questions need to be resolved.

- Will proactive compliance testing be done, audit testing or will this be done on complaint only basis?
- Consideration also needs to be given to how sampling will occur, how the lot is determined and whether a sample or the entire lot will fail.
- Educating the Weights and Measures community on moisture allowance and water activity.
- What are weights and measures protecting consumers and businesses from?

Summary of Discussions and Actions:

At the 2022 NCWM Interim Meeting, Dr. Lippa (NIST OWM) responded to general comments and answered questions that were posed to OWM as to what OWM can do with language within the NIST Handbooks. Dr. Lippa stated that OWM is in discussion with NIST Office of Chief Counsel regarding the cannabis agenda items at NCWM.

There are a few things for NIST related work: development to standards materials, high and low THC, and standards. There needs to be a distinction of the THC level that is regulated by the Farm Bill and the Controlled Substance Act (CSA).

NIST OWM Analysis
2024 NCWM Interim L&R Agenda Items

According to the CSA, high THC marijuana is an illegal drug and NIST cannot support guidance, training, and standards. Recognizing this issue, NIST will be able to publish Handbook 130 with this item, but they will have to provide a disclaimer citing the CSA. OWM is in communication with NIST legal counsel on this matter and will continue to work and advice with NIST legal.

The Committee requested the Cannabis TG submit information and data supporting their proposed moisture loss allowance, but it was not received. The Committee did not believe this item was ready for a Voting status and removed it from Block 3. This is assigned back to the NCWM Cannabis TG for additional development and to conduct a study relative to moisture loss allowance for Cannabis. They should establish data supporting the moisture loss allowance that the TG recommended. The Committee heard concerns that should the current moisture loss allowance be accepted without a study, the NCWM would be setting a precedence for future moisture loss allowance requests. The Committee considered comments urging the Committee to move forward with the $\pm 3\%$ moisture loss allowance but believes it would be imprudent to accept a moisture loss allowance without supporting data.

The Committee requested that the NCWM Cannabis TG follow NIST Handbook 130, NCWM, Interpretations and Guidelines Section 2.5.6. "Guidelines for NCWM Resolution of Requests for Recognition of Moisture Loss in Other Packaged Products" to establish the moisture allowances (loss and gain).

At the NCWM 2022 Annual Meeting, the Committee heard from the Cannabis TG Co-Chair Rutherford that work on studying moisture loss had begun with the State of Michigan, a packaging company, and a Cannabis provider to study moisture loss. David Sefcik shared the NIST OWM Executive comments.

At the 2023 NCWM Interim Meeting, Craig Van Buren (Michigan) supported this moving forward as a Voting item. but noted they are having issues obtaining chambers and the product to produce key data for submittal to the TG. They hope to have the data by the 2023 CWMA Meeting. David Sefcik read from the NIST OWM Executive and remarked that the courts would consider this arbitrary. They encouraged states to participate in the Cannabis Moisture Loss study. They also recommended that a national environmental or any type of study should consider different types of packaging. This proposal needs to be for moisture loss and gain and real-world data is needed, not just laboratory data. Data should not be collective of one to two industries. This includes a requirement of a moisture gain of up to 3 % and HB133 does not address moisture gain. In addition, a modification to NIST HB133 is needed to include procedures to assist inspectors. Negative average errors, not a positive error and inspectors need guidance.

Cannabis TG Co-Chair Wolpert (Arizona) that part of the study is a simulated environment. We can simulate to condense down and this is what is occurring. There is a broad range of packaging options. This is a young industry and everyone is doing their own thing and best practice is not developed. Need to limit our variables (simulated study). Industry has raised hemp water activity to bring NCWM along with everyone else including industry for hemp standards.

The Committee kept this Item Assigned to the NCWM Cannabis TG and encourages the completion of the study to determine the moisture allowance.

At the 2023 NCWM Annual Meeting, Cannabis Co-Chair Rutherford had no update, but expected the testing being conducted by Michigan to be completed soon and have the results for the 2024 NCWM Interim Meeting.

Regional Association Reporting:

Western Weights and Measures Association

At the 2021 WWMA Annual Meeting, Wendy Hahn expressed concern with percentages of THC were of a more qualitative nature and not necessarily within the purview of weights and measures. Kurt Floren (Los Angeles County, California) addressed the comments and concerns on quality issues as a general matter is not our purview in weights and measures. They mentioned how quality issues are a purview of weights and measures in matters of fuel with octane levels and viscosity of oils that must meet standards. They also mentioned that this would be similar in Cannabis, in that THC levels are a part of the identity of the product, and that it is an important component in determining the value and allowing for value comparison. Kurt Floren stated that States are in different stages of regulation, and there is going to be a need for uniform standards. Joe Moreo (Trinity County, California) provided testimony that different species including Cannabis indica and Cannabis ruderalis should also be provided in the definition. Lisa Warfield (NIST OWM) provided testimony that was based on the OWM Analysis that was submitted as the supporting documentation.

The WWMA Committee recommends that this item be further developed. The Committee recommends reviewing the OWM analysis supporting documentation and addressing the concerns with testing procedure, testing equipment, and the need for technical studies regarding moisture loss and gain.

At the 2022 WWMA Annual Meeting, the L&R Committee did not solicit comments on this item, and recommends this item continues as Assigned to the NCWM Cannabis TG.

At the 2023 WWMA Annual Meeting, Vince Wolpert (Cannabis TG Co-Chair) requested that this item remain Assigned. It was also stated that the analysis of moisture loss has been completed and is being compiled by Craig VanBuren (Michigan). The Cannabis TG will be making recommendations regarding moisture loss once that data has been compiled and analyzed. This may include water activity information as well.

Matt Douglas (California Department of Food and Agriculture, Division of Measurement Standards) supported an Assigned status, and is looking forward to the report.

The WWMA recommends this item remain Assigned to the Cannabis TG.

Central Weights and Measures Association

At the 2021 CWMA Interim Meeting, there was no discussion related to this item. Ivan Hankins (Iowa) supports the item moving forward with Voting status and suggests the development of a handbook for states who regulate cannabis. Based on comments during open hearings, supporting documents and discussions, the Committee believes this item is fully developed and ready for Voting status.

At the 2022 CWMA Annual Meeting, Lisa Warfield recommended this as a Developing Item or Assigned to the Cannabis Task Group to obtain additional information that OWM has recommended in their analysis.

At the 2022 CWMA Interim Meeting, Craig VanBuren commented that his state is collecting data and is hopeful it will be ready for review by the 2023 NCWM Interim meeting, but certainly by the 2023 Annual Meeting. He believes it is ready for Voting status pending results of the data. Charlie Rutherford commented he appreciates the nearly unanimous support for this item from the CWMA. Doug Musick

NIST OWM Analysis
2024 NCWM Interim L&R Agenda Items

and Loren Minnich (Kansas) supported the item and believed it is ready for Voting status. Ivan Hankins (Iowa) concurred. Based on comments from open hearings, the Committee believes the item is fully developed and ready for Voting status. The Committee is aware once the data is collected, changes may occur to the original item, or the item may be deescalated if necessary.

At the 2023 CWMA Annual Meeting, no comments were received and the Committee recommends this as an Assigned item.

At the 2023 CWMA Interim Meeting, Greg VanderPlaats (Minnesota) commented they believe the items should remain as an Assigned item until we have additional data. The Committee agreed that the item should remain Assigned to the Task Group.

Southern Weights and Measures Association

At the 2021 SWMA Annual Meeting, the Committee believed this Item is fully developed and recommended it to go to the NCWM L&R Committee with a Voting status. The Committee recommended the Cannabis TG take into consideration recommendations from the OWM Analysis, i.e., the survey to State Directors, this could help identify the need for development of items in other sections of the Handbooks, i.e., Powers and Duties of the Director.

At the 2022 SWMA Annual Meeting, Charlie Rutherford provided a quick update that a cannabis company is willing to give flower for free and Michigan will begin the testing soon and anticipates an update to report at the NCWM 2023 Annual Meeting.

The Committee recommended this item to remain Assigned.

At the 2023 SWMA Annual Meeting, they recommend this item remained assigned and awaits the upcoming data.

Northeastern Weights and Measures Association

At the 2021 NEWMA Interim Meeting, David Sefcik commented that this item seeks to set a moisture allowance (loss or gain) and to his knowledge no work has been done or data provided to determine support the proposed plus or minus allowance. It appears to be arbitrary. Mike Sikula concurs and questioned if water activity and moisture content are the same thing? Dr. Curran commented that water activity is free water available in the product. Moisture content measures the content of water in the product. Cheryl Ayer asked if it is necessary for the lower-case cannabis to be used in parenthesis. Matt Curran suggested it was a way to clarify terms. Charlie Rutherford commented that the TG believes the item is developed “enough” to be granted Voting status to have something in place to combat consumer fraud. Lisa Warfield recommended removal of the allowance in Table 2.3 and that it be placed in its own table and who would be responsible for training. The Committee recommends that NET 22.1 only be given Assigned. The Committee recommends that the TG review the OWM analysis for this item and address the need for technical studies (data) for moisture loss and gain.

At the 2022 NEWMA Annual Meeting, John McGuire noted that the NCWM Cannabis TG, NCWM L&R Committee, and the NEWMA L&R Committee recommends removing this block and making them individual items to ensure each item is fully considered.

James Cassidy noted the TG continues to work on dealing with moisture content and moisture in the case of cannabis is the opposite of what weight and measures is familiar with (moisture loss vs. moisture

content). They related an analogy as to how a humidifier operates to protect cigars, so cannabis needs to have a certain moisture content to be a viable product and needs to be tested that way. James Cassidy questioned NIST's role in publishing these items. Tina Butcher responded, "once the NCWM votes and passes specific language, it is NIST's intent to publish the content, subject to legal review, reflecting that NIST does not have a policy role as to marijuana's status as a Schedule 1 controlled substance." NEWMA L&R Committee recommends this item continues to be an Assigned Item.

At the 2022 NEWMA Interim Meeting, Charlie Rutherford reported that Craig VanBuren is waiting on some implementation details to be clarified before work can begin in his lab. The Committee recommends this remain as an Assigned Item.

At the 2023 NEWMA Annual Meeting, Cannabis Co-Chair Rutherford noted Craig Van Buren is in the process of conducting a study at Michigan's lab that will provide insight to the task group on moisture deviation above and below proposed thresholds. The results will be presented at the NCWM annual meeting in July.

The Committee recommends this remain as an Assigned Item.

At the 2023 NEWMA Interim Meeting, Lou Sakin (Holliston Massachusetts and representing the Cannabis Task Group) stated this item is not ready to move forward and is awaiting data from testing results Craig VanBuren.

NET-24.1 Section 3.11. Ice Cream Novelties.

Source: County of Los Angeles Department of Agriculture Commissioner/Weights and Measures

Submitter's Purpose and Justification:

Add to the procedure and provide technical guidance on the preparation and maintenance of ice water at the required temperature to test ice cream novelties such as ice cream bars, ice cream sandwiches, or cones.

The existing Handbook 133 procedure does not include guidance on the preparation of chilled water as an immersion fluid at the required temperature [1 °C (33 °F) or below]. As such, it can be difficult to maintain the immersion fluid for a reliable duration at the required temperature [1 °C (33 °F) or below] after the chilled water is poured into the displacement vessel. Water temperature exceeding 1 °C (33 °F) will result in the potential melting or softening of the ice cream or frozen novelty, thus resulting in inaccurate testing data and consequently invalidate or invite challenges to the inspection findings.

Testing Data

Data Analysis and Summary Justification

The following data summarizes the test of various materials for displacement vessels for this procedure. Materials considered were acrylic and metal in a variety of settings (ambient, with insulation, with insulation and prior chilling in freezer). These materials were chosen to reflect the variety used in typical, current displacement vessel fabrication.

The acrylic displacement vessel, combined with the insulation shield (with prior chilling), had the most favorable and reliable results for temperature stability. With the insulation and prior chilling, temperature stability in the acrylic displacement vessel significantly increased from 53 seconds of maintaining the temperature below 33.1 °F to 93 minutes and 53 seconds.

I. Displacement Vessel at Room Temperature (Without Insulation Shield)

Data below recorded length of time that water temperature stayed below 33.1°F.

| Tester Material | Time (min: sec) |
|-----------------|-----------------|
| Metal | 00:00 |
| Acrylic | 00:53 |

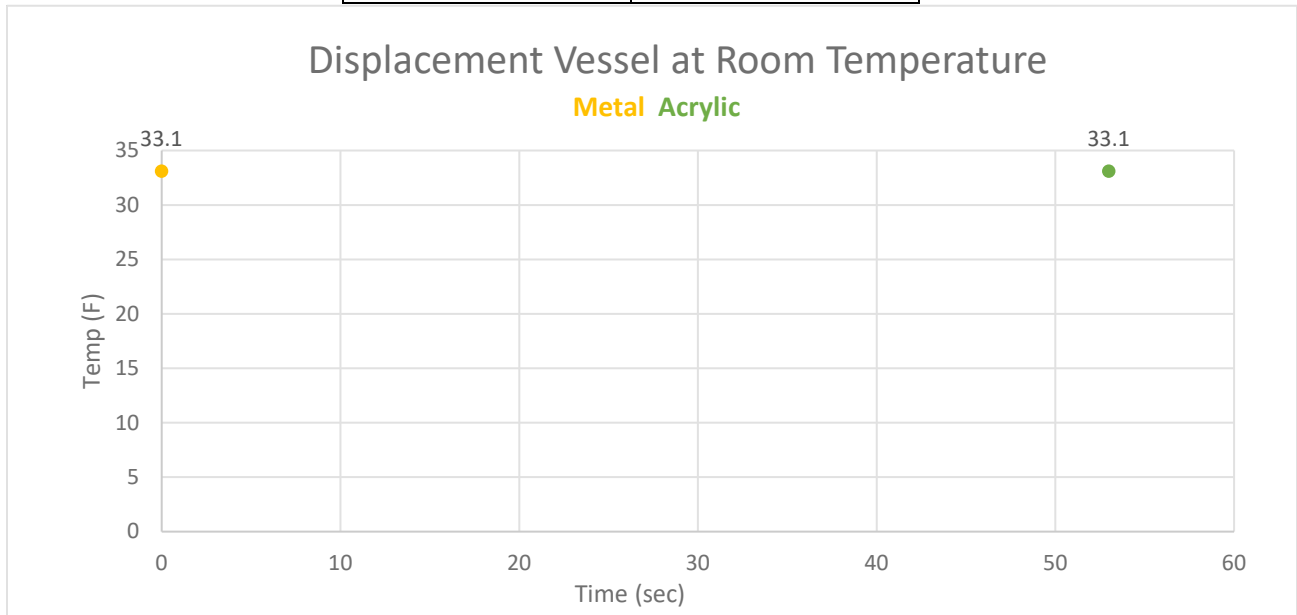

II. Displacement Vessel at Room Temperature (With Insulation Shield)

Data below recorded length of time that the water temperature stayed below 33.1°F.

| Tester Material | Time (min: sec) |
|-----------------|-----------------|
| Metal | 00:00 |
| Acrylic | 00:52 |

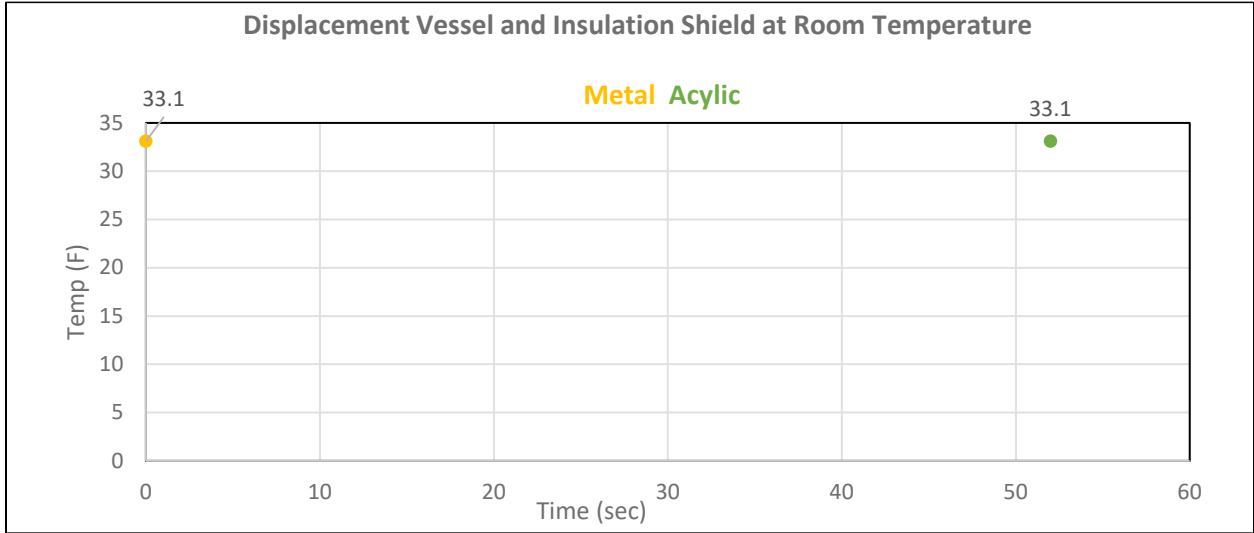

III. Displacement Vessel Chilled in Freezer for 30 minutes Prior to Test (Without Insulation Shield)

Prior to the testing, the displacement vessel was chilled in freezer prior to test for half an hour (30 mins).

Data below recorded length of time that the water temperature stayed below 33.1°F.

| Tester Material | Time (min: sec) |
|-----------------|-----------------|
| Metal | 06:30 |
| Acrylic | 13:22 |

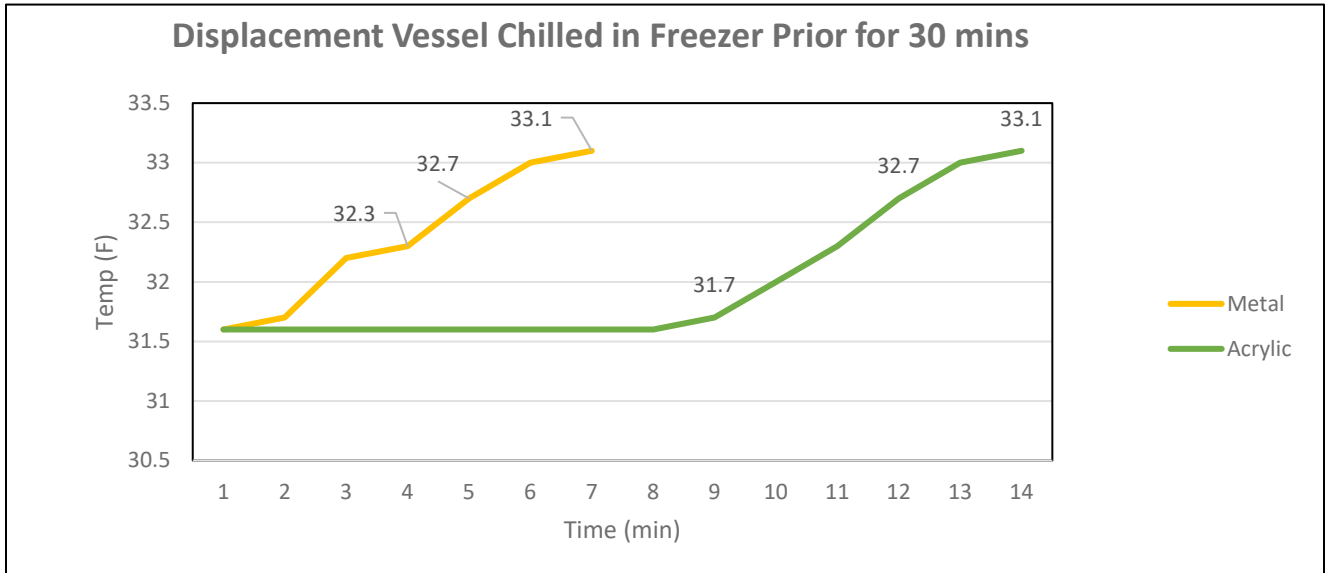

IV. Displacement Vessel and Insulation Shield Chilled in Freezer for 30 minutes Prior to Test

Prior to the testing, displacement vessel and insulation shield chilled in freezer for half an hour (30 mins).

Data below recorded length of time that the water temperature stayed below 33.1°F.

| Tester Material | Time (min: sec) |
|-----------------|-----------------|
| Metal | 36:16 |
| Acrylic | 93:50 |

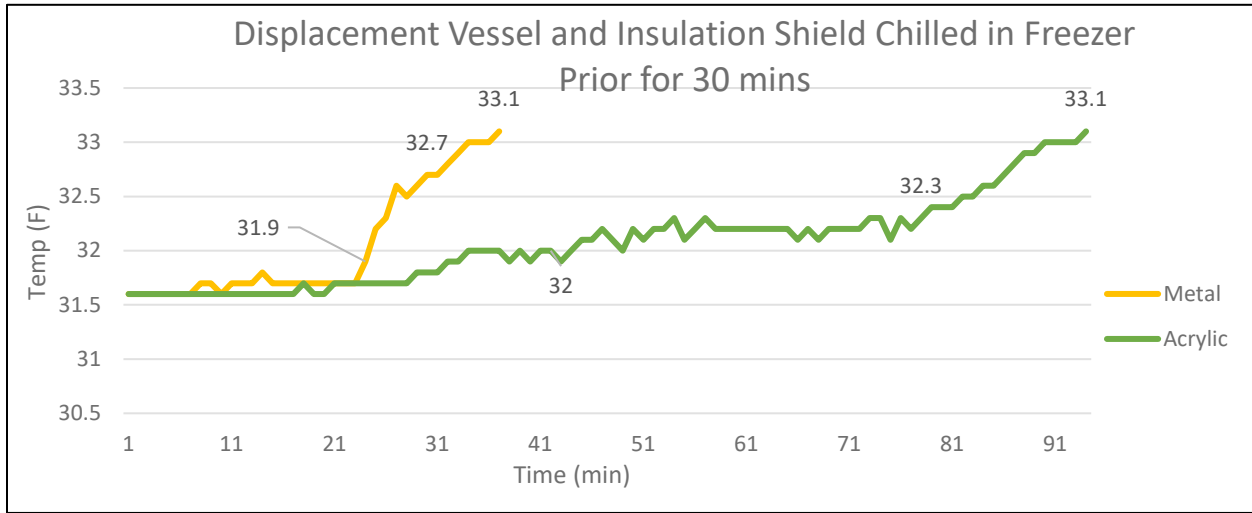

The submitter asked that this be an Informational Item in 2024.

| NIST OWM Executive Summary for NET-24.1 – Section 3.11. Ice Cream Novelties |
|---|
| <p>NIST OWM Recommendation: OWM recommends this item be Developing.</p> <ul style="list-style-type: none"> • Modify the title to include all packaged ice cream and similar frozen products. We recommend the aligning with language similar to the NIST Handbook, Method of Sale, Section 1.7.1. Factory Packaged Ice Cream and Similar Frozen Products”. • OWM recommends that the formatting standard be used to have the graphics be placed below where it is mentioned in the Test Procedure and not within the Test Equipment. • In 3.11.1. Test Equipment, under the Insulation Shield, NIST OWM recommends it read as follows: <ul style="list-style-type: none"> • <u>Insulation Shield</u> <ul style="list-style-type: none"> ➤ <u>Styrofoam Board – minimum one-inch-thick</u> ➤ <u>Styrofoam glue</u> |

The remaining portion of the submitters descriptor for the Insulation Shield should be moved under Step 4, as this is part of the Test Procedure.

The insulation shield should be assembled with dimensions that will cover as much surface area of the displacement vessel and minimal gaps between the seams (see Figure 3-7(b)(c)(d), “Example of an insulation shield with displacement vessel”). The purpose of the insulation shield is to reduce thermal transfer from the ambient environment to the displacement vessel in order to maintain the immersion fluid at 1 °C (33 °F) or below, as consistently as possible during testing.

In Section 3.11.1. Test Equipment, we recommend the following clarification to the test equipment identified.

- Change the following: Freezer or ice chest **~~containing and dry ice.~~**
- Add a new line item and include OSHA require standards for handling dry ice:
 - **Ice Cubes or Dry Ice (Safe Handling and Storage of Dry Ice | OSHA Safety Manuals (Safe Handling and Storage of Dry Ice | OSHA Safety Manuals <https://www.safetymanualosha.com/safe-handling-and-storage-of-dry-ice/>**
- Define what an insulation blanket is under **Plastic Pitcher with insulation blanket.**
- Define what type of Strainer is required.
- In Section 3.11.2. Test Procedure, Step 2, needs to be clarified. The displacement vessel and the insulation shield should be in the freezer or ice chest “**separately,**” or “**assembled together**”? (Step 5 states “**When the displacement vessel and the insulation shield are both chilled and ready to be used, assemble them together (see Figure 3-7(b)(c)(d)).**”

Does it have a different effect/result if they are combined within the freezer? We also question the effectiveness of placing a container of water in a “refrigerator” versus a freezer to assist with the chilling process.

- Step 4 (new), the following ratio is defined: **Water: Dry ice: Ice cubes = 6 : 1 : 2.** This ratio needs to be clarified. For example, what does 6 parts of water mean? What does 2 parts dry ice mean? And what does 2 parts ice cubes mean? Can a ratio between the water, dry ice, ice cubes be defined?
- Step 14 and Step 15 (new), implies that Step 2 (freezing the displacement vessel and Styrofoam insulation shield) is not needed to be repeated. Does the data support that freezing the defined test equipment in Step 2, and maintaining the equipment at the required temperature for one test or possibly for 12 tests? When must the inspector refreeze the displacement vessel and Styrofoam insulation shield?
- OWM recommends that more testing be done by other counties and/or states to support the results. The results submitted are only based on two to three tests.

**Table 2. Summary of Recommendations
 NET-24.1 – Section 3.11. Ice Cream Novelties**

| | Status Recommendation | Note* | Comments |
|-----------|-----------------------|-------|----------|
| Submitter | Informational | | |
| OWM | Developing | | |
| WWMA | Voting | 1 | |
| NEWMA | Developing | | |
| SWMA | Developing | | |
| CWMA | Assigned | | |
| NCWM | | | |

***Notes Key:**

- 1 Submitted modified language
- 2 Item not discussed
- 3 No meeting held
- 4 Not submitted on agenda
- 5 No recommendation or not considered

Item Under Consideration:

(NIST OWM has applied the appropriate formatting according to NIST Handbooks)

Amend Handbook 133, Checking the Net Contents of Packaged Goods, as follows:

3.11. Ice Cream Novelties

Note: The following procedure can be used to test packaged products that are solid or semisolid and that will not dissolve in, mix with, absorb, or be absorbed by the fluid into which the product will be immersed. ~~For example, ice cream and frozen novelties labeled by volume can be tested using icechilled water or kerosene~~ as the immersion fluid.

Exception: Pelletized ice cream is beads of ice cream which are quick frozen with liquid nitrogen. The beads are relatively small but can vary in shape and size. On April 17, 2009, the FDA issued a letter stating that this product is considered semisolid food, in accordance with 21 CFR 101.105(a). The FDA also addresses that the appropriate net quantity of content declaration for pelletized ice cream products be in terms of net weight.

(Added 2010)

The following volume displacement procedure uses a displacement vessel specifically designed for ice cream novelties such as ice cream bars, ice cream sandwiches, or cones. The procedure determines the volume of the novelty by measuring the amount of water displaced when the novelty is submerged in the vessel. Two displacements per sample are required to subtract the volume of sticks or cups.

The procedure first determines if the densities of the novelties are the same from package to package (in the same lot) so that a gravimetric test can be used to verify the labeled volume. If a gravimetric procedure is used, compute an average weight for the declared volume from the first two packages and

weigh the remainder of the sample. If the gravimetric procedure cannot be used, use the volume displacement procedure for all of the packages in the sample.

3.11.1. Test Equipment

- A scale that meets the requirements in Section 2.2. “Measurement Standards and Test Equipment”
- Volumetric measures
- Displacement vessel with dimensions appropriate for the size of novelties being tested (see Figure 3-7(a), “Example of a Displacement Vessel”). It should include an interior baffle that reduces wave action when the novelty is inserted and a downward angled overflow spout to reduce dripping. Other designs may be used.

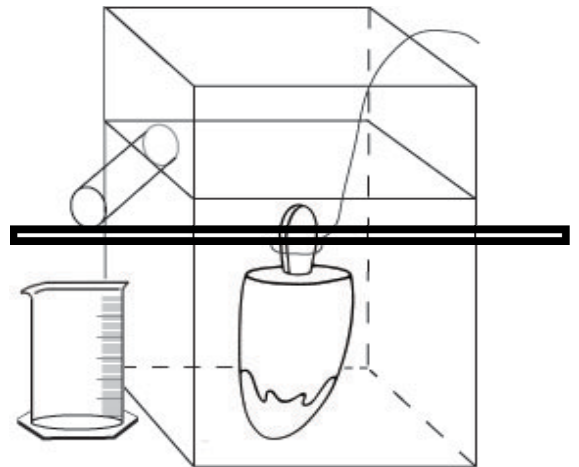
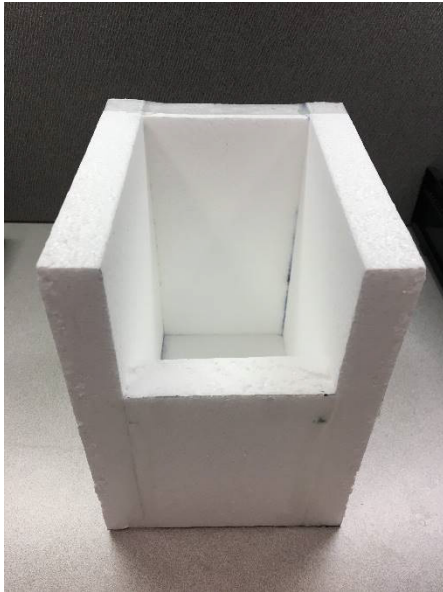

Figure 3-7(a). Example of a Displacement Vessel.

- **Insulation shield**
 - **Minimum one-inch-thick Styrofoam board**
 - **Styrofoam glue**

NOTE: Use a minimum of one-inch-thick Styrofoam board to assemble the insulation shield. The insulation shield should be assembled with dimensions that will cover as much surface area of the displacement vessel and with as few gaps as possible (see Figure 3-7(b)(c)(d) Example of an insulation shield with displacement vessel).

The purpose of this equipment is to reduce thermal transfer from ambient environment to the displacement vessel in order to maintain the immersion fluid at 1 °C (33 °F) or below as consistently as possible during testing.



(b)

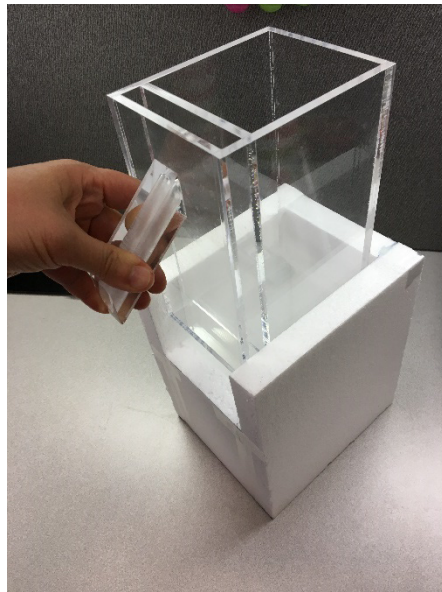

(c)

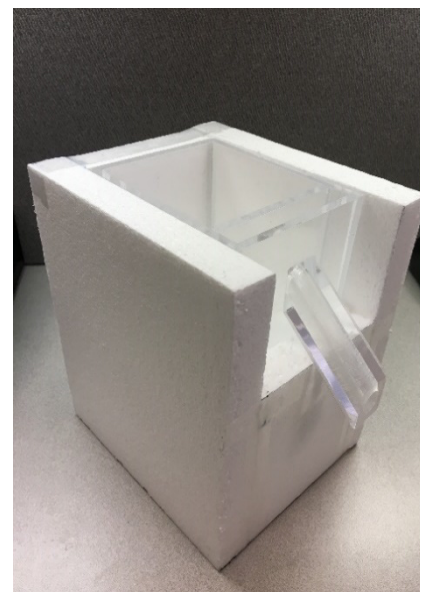

(d)

Figure 3-7(b)(c)(d). Example of an Insulation Shield with Acrylic Displacement Vessel,

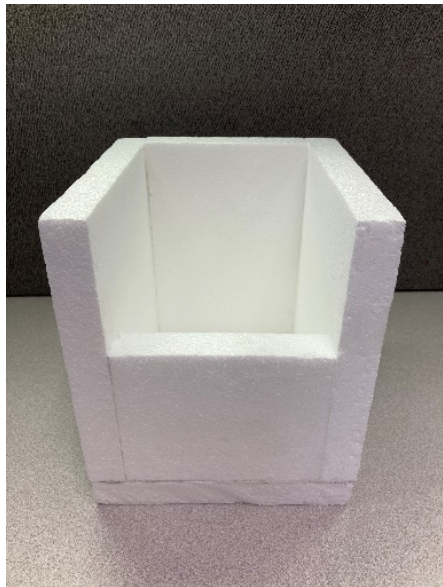

(e)

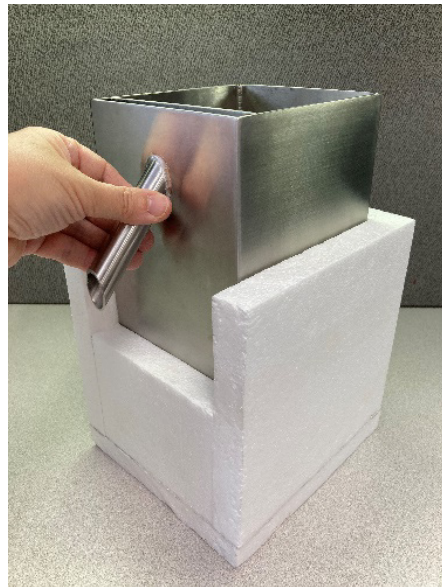

(f)

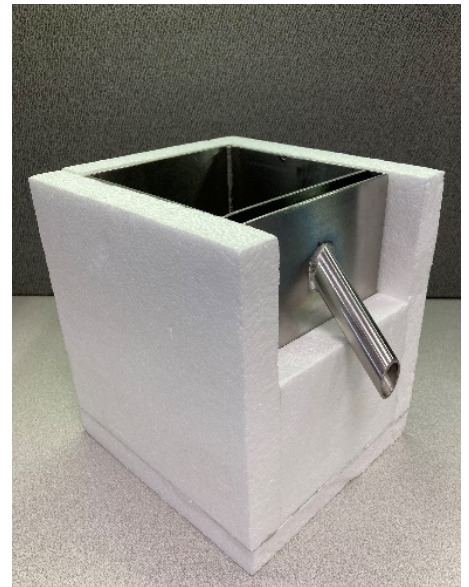

(g)

Figure 3-7(e)(f)(g). Example of an Insulation Shield with Metal Displacement Vessel

- Thin wire, clamp, or tongs
- Freezer or ice chest **containing and** dry ice
- Single-edged razor or sharp knife (for sandwiches only)
- **Prepared, chilled** water ~~kerosene~~ maintained at 1 °C (33 °F) or below

- Water, ice cubes, dry ice, pitcher with insulation blanket
- Cryogenic gloves (for handling dry ice)
- Plastic Pitcher with insulation blanket
- Strainer
- Indelible marker (for ice pops only)
- Level, at least 152 mm (6 in) in length
- Partial immersion thermometer or equivalent with 1 °C (2 °F) graduations and a – 35 °C to + 50 °C (– 30 °F to + 120 °F) accurate to ± 1 °C (± 2 °F)
- A tabletop, laboratory-type jack of sufficient size to hold the displacement vessel
- Stopwatch

3.11.2. Test Procedure

| |
|--|
| 1. Follow the procedures in Section 2.3.1. “Define the Inspection Lot.” Use a “Category A” sampling plan in the inspection; and select a random sample. |
| 2. <u>Place the displacement vessel and insulation shield in a freezer or an ice chest filled with dry ice for at least 30 minutes prior to testing. It is advisable to pre-chill water for use as immersion fluid in a sufficient volume to fill the displacement vessel and to replenish as needed throughout the testing procedures by placing a container of water in a refrigerator or ice chest during the same period.</u> Maintain the <u>ice cream or frozen novelty</u> samples at the reference temperature for frozen products that is specified in Table 3-1. “Reference Temperatures for Liquids.” Place the samples in the freezer or ice chest until they are ready to be tested, and then remove packages from the freezer one at a time. |
| 3. According to the type of novelty, prepare the sample products as follows: |
| ➤ *Ice-pop. Mark on the stick(s) with the indelible marker the point to which the ice-pop will be submerged in the <u>prepared, chilled</u> water. (After the ice-pop contents have been submerged, remove the novelty to determine the volume of the stick.) |
| ➤ *Cone. Make a small hole in the cone below the ice cream portion to allow air to escape. |
| ➤ Sandwich. Determine whether the declared volume is (a) the total volume of the novelty (that is, including the cookie portion) or (b) the volume of the ice-cream-like portion only. If the declared volume is the volume of only the ice-cream-like portion, shave off the cookie with a razor or knife, leaving some remnants of cookie to ensure that no ice cream is accidentally shaved off. Work quickly and return the novelty to the freezer before the sandwich softens. |
| ➤ Cup. Remove the cap from the cup. |
| <u>4. Prepare immersion fluid to a temperature of 1 °C (33 °F) or below by adding dry ice and ice cubes to water in a plastic pitcher.</u> |

For best results, wrap the pitcher with an insulation blanket to prevent heat transfer from the ambient environment. Monitor the water temperature throughout this procedure by placing the thermometer in the center position of the pitcher.

Note: Be cautious while handling dry ice due to its very low temperature (-109 °F); handle it with cryogenic gloves to prevent frostbite or freezer burns to skin.

Note: Dry ice (-109 °F) is the key ingredient for the chilled water immersion fluid preparation because of its very low temperature. However, while the dry ice lowers the water mixture temperature, the water surface that is in contact with the ambient air in the testing environment is also constantly gaining heat due to heat transfer. To resolve this problem, add ice cubes to the water; the ice cubes will float and form an insulation barrier, thereby, allowing water temperature to be maintained at the required temperature. The ratio to make the prepared, chilled water (can reach as low as 31.6 °F) are as follows:

Water : Dry ice : Ice cubes = 6 : 1 : 2

Note: Monitoring of the temperature of the chilled water immersion fluid should be conducted throughout the testing. At any time that the chilled water temperature exceeds 1 °C (33 °F), a new batch of chilled water at the required temperature will need to be prepared to validate the testing procedure.

5. When the displacement vessel and the insulation shield are both chilled and ready to be used, assemble them together (see Figure 3-7(b)(c)(d)).

64. Fill the displacement vessel with **ice-prepared, chilled** water until it overflows the spout. **Use a strainer to prevent ice cubes or dry ice chunks from flowing into the displacement vessel.** Allow it to sit until dripping stops. Raise the displacement vessel **with a tabletop laboratory-type jack** as necessary and place the graduate **of appropriate capacity** beneath the spout.

75. Remove a package from the freezer, determine its gross weight, and record it.

86. Submerge the novelty as suggested until it is below the surface level of the water.

- **Ice-pop.** Use a clamp, tongs, or your fingers to hold the stick(s) and submerge the ice-pop to the level marked in Step 3 of the Test Procedure.
- **Cone.** Shape the wire into a loop, and use it to push the cone, headfirst (ice cream portion first) into the **prepared, chilled** water. Do not completely submerge the cone immediately: let water fill the cone through the hole made in Step 3 of the Test Procedure before completely submerging the novelty.
- **Sandwich or cup.** Skewer the novelty with the thin wire or form a loop on the end of the wire to push the sandwich or ice cream portion or cup completely below the liquid level

97. Record the total water volume in the graduate.

- For a cone or sandwich, record the water volume as the net volume and go to Step 9.
- For ice-pops or cups, record the water volume in the graduate as the gross volume and go to Step 8.

108. Refill the displacement vessel with **prepared, chilled** water to overflowing and reposition the empty graduate under the spout. After the cup and novelty contents have been submerged, remove the novelty from the cup to determine the volume of the cup.

| |
|---|
| <p>➤ Ice-pop. Melt the ice-pop off the stick or sticks. Submerge the stick or sticks to the line marked in Step 3. Record the volume of tare material (i.e., stick) by measuring the water displaced into the graduate. The net volume for the ice-pop is the gross volume recorded in Step 7 minus the volume of the tare materials in this step. Record this volume as the “volume of novelty.” To determine the error in the package, subtract the labeled quantity from the volume of novelty.</p> |
| <p>➤ Cup. Remove the novelty from the cup. Rinse the cup, and then submerge it in the displacement vessel. Small pinholes in the base of the cup can be made to make submersion easier. Record the volume of water displaced into the graduate by the cup as the volume of tare material. The net volume for the novelty is the gross volume determined in Step 7 minus the volume of the tare materials determined in this step. Record this as the net volume of the novelty. To determine the error in the package, subtract the labeled quantity from the volume of novelty.</p> |
| <p>11.9. Clean and air-dry the tare materials (sticks, wrappers, cup, lid, etc.). Weigh and record the weight of these materials for the package.</p> |
| <p>12.10. Subtract the tare weight from the gross weight to obtain the net weight and record this value.</p> |
| <p>13.11. Compute the weight of the labeled volume for the package using the following formula and then record the weight:</p> $\text{Product Density} = (\text{product net weight in Step 10}) \div (\text{the total water volume in Step 7} - \text{volume of tare material in Step 8})$ $\text{Weight of labeled volume} = (\text{labeled volume}) \times (\text{Product Density})$ |
| <p>14.12. Repeat Steps 3 through 11 for a second package.</p> |
| <p>15.13. If the weight of the labeled volumes in Step 11 for the two packages differs from each other by more than one division on the scale, the gravimetric test procedure cannot be used to test the sample for compliance. If this is the case, use Steps 3 through 8 for each of the remaining packages in the sample to determine their net volumes and package errors. Then go to evaluation of results. If the weights of the labeled volumes agree within one division, continue to Step 14 to test the rest of the sample using the gravimetric test procedure.*</p> |
| <p>16.14. Use Section 2.3.5.1. “Determination of Tare Sample and Average Tare Weight” to determine the Average Used Dry tare Weight of the sample.</p> |
| <p>17.15. Find the Average Product Density by adding the densities of the product from the two packages and dividing the sum by two.</p> |
| <p>18.16. Using the weight of labeled volume determined in Step 11, calculate the Average Product Weight by multiplying the weight of the labeled volume by the average product density.</p> $\text{*Average Product Weight} = \text{Labeled Volume} \times \text{Average Product Density}$ |
| <p>19.17. Calculate the “nominal gross weight” using the formula:</p> $\text{Nominal Gross Weight} = \text{Average Product Weight} + \text{Average Used Dry Tare Weight}$ |
| <p>20.18. <u>Weigh the remaining packages in the sample.</u></p> |
| <p>21.19. Subtract the nominal gross weight from the gross weight of each package to obtain package errors in terms of weight.</p> <p>Note: Compare the sample packages to the nominal gross weight.</p> |
| <p>22.20. Determine the average package error by totaling all package errors and dividing by the number of packages in the sample.</p> |

To convert the average error or package error from weight to volume, use the following formula:
$$\text{Package Error in Volume} = (\text{Package Error in Weight}) \div (\text{Average Product Density})$$

3.11.3. Evaluation of Results

Follow the procedures in Section 2.3.7. “Evaluate for Compliance” to determine lot conformance.

NIST OWM Detailed Technical Analysis:

NIST OWM recognizes the challenges of maintaining the ice water used in the displacement vessel at or below 1 °C (33 °F). We are in support of the development of this proposal which will improve testing procedures. Below are some recommendations for the continued development of this proposal.

Modify the title to include all packaged ice cream and similar frozen products. We recommend the aligning with language similar to the NIST Handbook, Method of Sale, Section 1.7.1. Factory Packaged Ice Cream and Similar Frozen Products”.

OWM recommends that the formatting standard be used to have the graphics be placed below where it is mentioned in the Test Procedure and not within the Test Equipment.

In 3.11.1. Test Equipment, under the Insulation Shield, NIST OWM recommends it read as follows:

- **Insulation Shield**
 - **Styrofoam Board – minimum one-inch-thick**
 - **Styrofoam glue**

The remaining portion of the submitters descriptor for the Insulation Shield should be moved under Step 4, as this is part of the Test Procedure.

The insulation shield should be assembled with dimensions that will cover as much surface area of the displacement vessel and minimal gaps between the seams (see Figure 3-7(b)(c)(d), “Example of an insulation shield with displacement vessel”). The purpose of the insulation shield is to reduce thermal transfer from the ambient environment to the displacement vessel in order to maintain the immersion fluid at 1 °C (33 °F) or below, as consistently as possible during testing.

In Section 3.11.1. Test Equipment, we recommend clarifying the test equipment.

Change the following: Freezer or ice chest ~~containing and dry ice~~. Then add a new item and OSHA safety standards to handling dry ice.

Ice Cubes or Dry Ice (Safe Handling and Storage of Dry Ice | OSHA Safety Manuals (Safe Handling and Storage of Dry Ice | OSHA Safety Manuals
<https://www.safetymanualosha.com/safe-handling-and-storage-of-dry-ice/>

Define what an insulation blanket is under **Plastic Pitcher with insulation blanket**. In addition, what type of Strainer is required?

In Section 3.11.2. Test Procedure, Step 2, needs to be clarified. The displacement vessel and the insulation shield should be in the freezer or ice chest “separately,” or “assembled together”? Step 5 states “When the displacement vessel and the insulation shield are both chilled and ready to be used, assemble them together (see Figure 3-7(b)(c)(d).” Does it have a different effect/result if they are combined within the freezer? We also question the effectiveness of placing a container of water in a “refrigerator” versus a freezer to assist with the chilling process.

Step 4 (new), the following ratio is defined: **Water: Dry ice: Ice cubes = 6 : 1 : 2**. This ratio needs to be clarified. For example, what does 6 parts of water mean? What does 2 parts dry ice mean? And what does 2 parts ice cubes mean? Can a ratio between the water, dry ice, ice cubes be defined?

Step 14 and Step 15 (new), implies that Step 2 (freezing the displacement vessel and Styrofoam insulation shield) is not needed to be repeated. Does the data support that freezing the defined test equipment in Step 2, and maintaining the equipment at the required temperature for one test or possibly for 12 tests? When must the inspector refreeze the displacement vessel and Styrofoam insulation shield?

OWM recommends and supports additional testing be done by other counties and/or states to support the results. The results submitted are only based on two to three tests.

Summary of Discussions and Actions

Regional Association Reporting:

Western Weights and Measures Association

At the 2023 WWMA Annual Meeting, a presentation was given by the submitter of this item during open hearings and is available on the WWMA website. The submitter recognized editorial changes submitted by Matt Douglas (CDFA-DMS). The submitter stated that this item is fully developed and would like Voting status.

Austin Shepherd (County of San Diego, California) voiced support for the proposal as voting.

Matt Douglas echoed the comments of Austin Shepherd, voicing support for the item with the adoption of their editorial changes.

Kurt Floren (Los Angeles County, California) stood as a proud boss, thanking Annie Tsou and Lina Ng for their hard work on this submission. Kurt Floren stated that it is absolutely critical to maintain the temperature of the water during this test procedure. Kurt Floren stated that this item also cleans up code, and fully supports this as a Voting item.

Jose Arriaga (Orange County, California) also voiced support for this item with the editorial changes.

The updated proposal is shown below. (Testing data was resubmitted with no changes. To view testing data, see “Submitter’s Purpose and Justification.”)

3.11. Ice Cream Novelties

Note: The following procedure can be used to test packaged products that are solid or semisolid and that will not dissolve in, mix with, absorb, or be absorbed by the fluid into which the product will be

immersed. ~~For example, ice~~ cream and frozen novelties labeled by volume can be tested using ~~ice~~chilled water ~~or kerosene~~ as the immersion fluid.

Exception: Pelletized ice cream is beads of ice cream which are quick frozen with liquid nitrogen. The beads are relatively small but can vary in shape and size. On April 17, 2009, the FDA issued a letter stating that this product is considered semisolid food, in accordance with 21 CFR 101.105(a). The FDA also addresses that the appropriate net quantity of content declaration for pelletized ice cream products be in terms of net weight.

(Added 2010)

The following volume displacement procedure uses a displacement vessel specifically designed for ice cream novelties such as ice cream bars, ice cream sandwiches, or cones. The procedure determines the volume of the novelty by measuring the amount of water displaced when the novelty is submerged in the vessel. Two displacements per sample are required to subtract the volume of sticks or cups.

The procedure first determines if the densities of the novelties are the same from package to package (in the same lot) so that a gravimetric test can be used to verify the labeled volume. If a gravimetric procedure is used, compute an average weight for the declared volume from the first two packages and weigh the remainder of the sample. If the gravimetric procedure cannot be used, use the volume displacement procedure for all of the packages in the sample.

3.11.1. Test Equipment

- A scale that meets the requirements in Section 2.2. “Measurement Standards and Test Equipment”
- Volumetric measures
- Displacement vessel with dimensions appropriate for the size of novelties being tested (see Figure 3-7(a), “Example of a Displacement Vessel”). It should include an interior baffle that reduces wave action when the novelty is inserted and a downward angled overflow spout to reduce dripping. Other designs may be used.

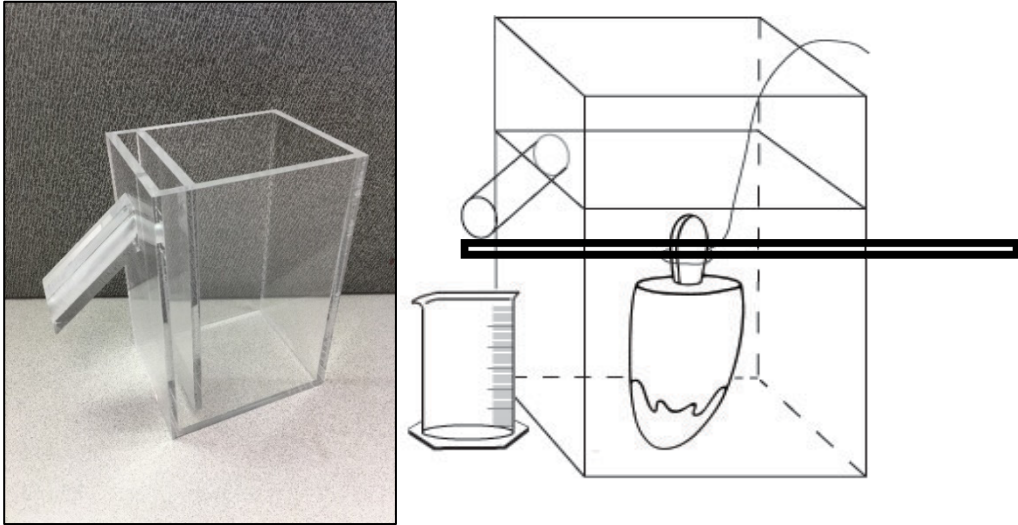
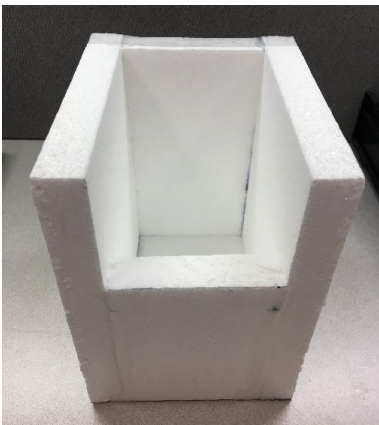

Figure 3-7(a). Example of a Displacement Vessel.

- **Insulation shield**
 - **Minimum one-inch-thick Styrofoam board**
 - **Styrofoam glue**

Use a minimum of one-inch-thick Styrofoam board to assemble the insulation shield. The insulation shield should be assembled with dimensions that will cover as much surface area of the displacement vessel and with as few gaps as possible (see Figure 3-7(b)(c)(d), “Example of an insulation shield with displacement vessel”). The purpose of this equipment is to reduce thermal transfer from ambient environment to the displacement vessel in order to maintain the immersion fluid at 1 °C (33 °F) or below as consistently as possible during testing.



(b)



(c)

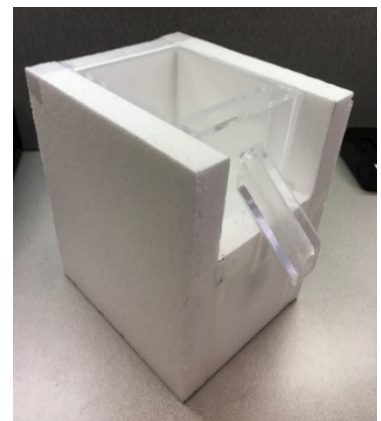

(d)

Figure 3-7(b)(c)(d). Example of an Insulation Shield with Acrylic Displacement Vessel.

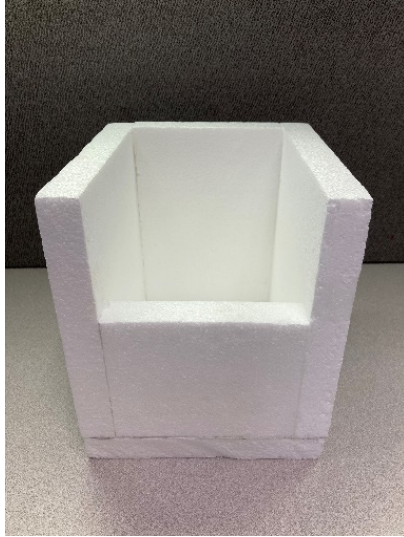

(e)

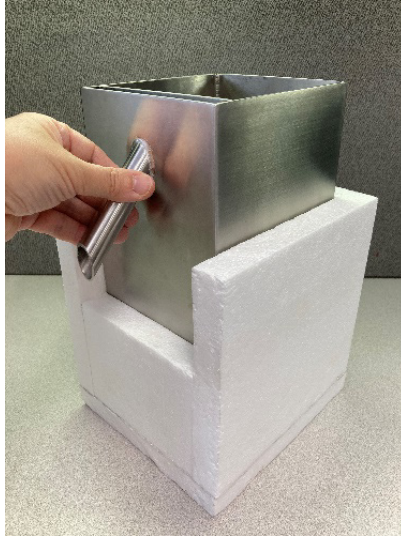

(f)

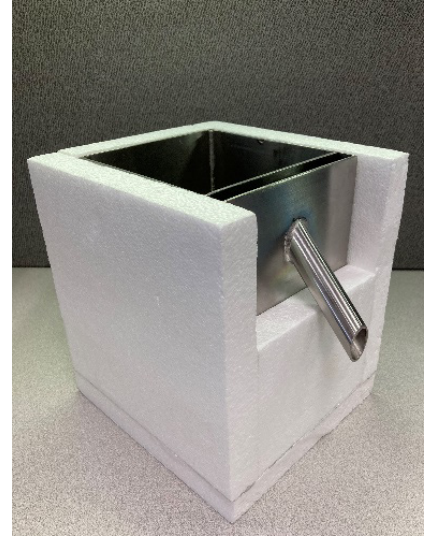

(g)

Figure 3-7(e)(f)(g). Example of an Insulation Shield with Metal Displacement Vessel

- Thin wire, clamp, or tongs
- Freezer or ice chest **containing and** dry ice
- Single-edged razor or sharp knife (for sandwiches only)
- **Prepared, chilled** water ~~/kerosene~~ maintained at 1 °C (33 °F) or below
 - **Water, ice cubes, dry ice, pitcher with insulation blanket**
- **Cryogenic gloves (for handling dry ice)**
- **Plastic Pitcher with insulation blanket**
- **Strainer**
- Indelible marker (for ice pops only)
- Level, at least 152 mm (6 in) in length
- Partial immersion thermometer or equivalent with 1 °C (2 °F) graduations and a – 35 °C to + 50 °C (– 30 °F to + 120 °F) accurate to ± 1 °C (± 2 °F)
- A tabletop, laboratory-type jack of sufficient size to hold the displacement vessel
- Stopwatch

3.11.2. Test Procedure

| | |
|------|---|
| 1. | Follow the procedures in Section 2.3.1. “Define the Inspection Lot.” Use a “Category A” sampling plan in the inspection; and select a random sample. |
| 2. | <u>Place the displacement vessel and insulation shield in a freezer or an ice chest filled with dry ice for at least 30 minutes prior to testing. It is advisable to pre-chill water for use as immersion fluid in a sufficient volume to fill the displacement vessel and to replenish as needed throughout the testing procedures by placing a container of water in a refrigerator or ice chest during the same period.</u> Maintain the <u>ice cream or frozen novelty</u> samples at the reference temperature for frozen products that is specified in Table 3-1. “Reference Temperatures for Liquids.” Place the samples in the freezer or ice chest until they are ready to be tested, and then remove packages from the freezer one at a time. |
| 3. | According to the type of novelty, prepare the sample products as follows: |
| | ➤ *Ice-pop. Mark on the stick(s) with the indelible marker the point to which the ice-pop will be submerged in the <u>prepared, chilled</u> water. (After the ice-pop contents have been submerged, remove the novelty to determine the volume of the stick.) |
| | ➤ *Cone. Make a small hole in the cone below the ice cream portion to allow air to escape. |
| | ➤ Sandwich. Determine whether the declared volume is (a) the total volume of the novelty (that is, including the cookie portion) or (b) the volume of the ice-cream-like portion only. If the declared volume is the volume of only the ice-cream-like portion, shave off the cookie with a razor or knife, leaving some remnants of cookie to ensure that no ice cream is accidentally shaved off. Work quickly and return the novelty to the freezer before the sandwich softens. |
| | ➤ Cup. Remove the cap from the cup. |
| 4. | <u>Prepare immersion fluid to a temperature of 1 °C (33 °F) or below by adding dry ice and ice cubes to water in a plastic pitcher.</u> <u>For best results, wrap the pitcher with an insulation blanket to prevent heat transfer from the ambient environment. Monitor the water temperature throughout this procedure by placing the thermometer in the center position of the pitcher.</u> <u>Note: Be cautious while handling dry ice due to its very low temperature (−109 °F); handle it with cryogenic gloves to prevent frostbite or freezer burns to skin.</u> <u>Note: Dry ice (−109 °F) is the key ingredient for the chilled water immersion fluid preparation because of its very low temperature. However, while the dry ice lowers the water mixture temperature, the water surface that is in contact with the ambient air in the testing environment is also constantly gaining heat due to heat transfer. To resolve this problem, add ice cubes to the water; the ice cubes will float and form an insulation barrier, thereby, allowing water temperature to be maintained at the required temperature. The ratio to make the prepared, chilled water (can reach as low as 31.6 °F) are as follows:</u> <u>Water : Dry ice : Ice cubes = 6 : 1 : 2</u> <u>Note: Monitoring of the temperature of the chilled water immersion fluid should be conducted throughout the testing. At any time that the chilled water temperature exceeds 1 °C (33 °F), a new batch of chilled water at the required temperature will need to be prepared to validate the testing procedure.</u> |
| 5. | <u>When the displacement vessel and the insulation shield are both chilled and ready to be used, assemble them together (see Figure 3-7(b)(c)(d)).</u> |
| 6.4. | Fill the displacement vessel with <u>ice-prepared, chilled</u> water until it overflows the spout. <u>Use a strainer to prevent ice cubes or dry ice chunks from flowing into the displacement vessel.</u> Allow it to sit until dripping |

| |
|---|
| <p>stops. Raise the displacement vessel with a tabletop laboratory-type jack as necessary and place the graduate of appropriate capacity beneath the spout.</p> |
| <p>7.5. Remove a package from the freezer, determine its gross weight, and record it.</p> |
| <p>8.6. Submerge the novelty as suggested until it is below the surface level of the water.</p> |
| <ul style="list-style-type: none"> ➤ Ice-pop. Use a clamp, tongs, or your fingers to hold the stick(s) and submerge the ice-pop to the level marked in Step 3 of the Test Procedure. ➤ Cone. Shape the wire into a loop, and use it to push the cone, headfirst (ice cream portion first) into the prepared, chilled water. Do not completely submerge the cone immediately: let water fill the cone through the hole made in Step 3 of the Test Procedure before completely submerging the novelty. ➤ Sandwich or cup. Skewer the novelty with the thin wire or form a loop on the end of the wire to push the sandwich or ice cream portion or cup completely below the liquid level. |
| <p>9.7. Record the total water volume in the graduate.</p> <ul style="list-style-type: none"> ➤ For a cone or sandwich, record the water volume as the net volume and go to Step 119. ➤ For ice-pops or cups, record the water volume in the graduate as the gross volume and go to Step 108. |
| <p>10.8. Refill the displacement vessel with prepared, chilled water to overflowing and reposition the empty graduate under the spout. After the cup and novelty contents have been submerged, remove the novelty from the cup to determine the volume of the cup.</p> <ul style="list-style-type: none"> ➤ Ice-pop. Melt the ice-pop off the stick or sticks. Submerge the stick or sticks to the line marked in Step 3. Record the volume of tare material (i.e., stick) by measuring the water displaced into the graduate. The net volume for the ice-pop is the gross volume recorded in Step 97 minus the volume of the tare materials in this step. Record this volume as the “volume of novelty.” To determine the error in the package, subtract the labeled quantity from the volume of novelty. ➤ Cup. Remove the novelty from the cup. Rinse the cup, and then submerge it in the displacement vessel. Small pinholes in the base of the cup can be made to make submersion easier. Record the volume of water displaced into the graduate by the cup as the volume of tare material. The net volume for the novelty is the gross volume determined in Step 97 minus the volume of the tare materials determined in this step. Record this as the net volume of the novelty. To determine the error in the package, subtract the labeled quantity from the volume of novelty. |
| <p>11.9. Clean and air-dry the tare materials (sticks, wrappers, cup, lid, etc.). Weigh and record the weight of these materials for the package.</p> |
| <p>12.10. Subtract the tare weight from the gross weight to obtain the net weight and record this value.</p> |
| <p>13.11. Compute the weight of the labeled volume for the package using the following formula and then record the weight:</p> $\text{Product Density} = (\text{product net weight in Step } \del{1210}) \div (\text{the total water volume in Step } \del{97} \text{ volume of tare material in Step } \del{108})$ $\text{Weight of labeled volume} = (\text{labeled volume}) \times (\text{Product Density})$ |
| <p>14.12. Repeat Steps 3 through 1311 for a second package.</p> |
| <p>15.13. If the weight of the labeled volumes in Step 1311 for the two packages differs from each other by more than one division on the scale, the gravimetric test procedure cannot be used to test the sample for compliance. If this is the case, use Steps 3 through 108 for each of the remaining packages in the sample to determine their net volumes and package errors. Then go to evaluation of results. If the weights of the labeled volumes agree within one division, continue to Step 1614 to test the rest of the sample using the gravimetric test procedure.*</p> |

| |
|--|
| 1614. Use Section 2.3.5.1. “Determination of Tare Sample and Average Tare Weight” to determine the Average Used Dry tare Weight of the sample. |
| 1715. Find the Average Product Density by adding the densities of the product from the two packages and dividing the sum by two. |
| 1816. Using the weight of labeled volume determined in Step 1311 , calculate the Average Product Weight by multiplying the weight of the labeled volume by the average product density. <i>*Average Product Weight = Labeled Volume × Average Product Density</i> |
| 1917. Calculate the “nominal gross weight” using the formula: <i>Nominal Gross Weight = Average Product Weight + Average Used Dry Tare Weight</i> |
| 2018. Weigh the remaining packages in the sample. |
| 2119. Subtract the nominal gross weight from the gross weight of each package to obtain package errors in terms of weight. |
| Note: Compare the sample packages to the nominal gross weight. |
| 2220. Determine the average package error by totaling all package errors and dividing by the number of packages in the sample. |
| To convert the average error or package error from weight to volume, use the following formula: <i>Package Error in Volume = (Package Error in Weight) ÷ (Average Product Density)</i> |

The Committee recommends this as a Voting Item.

Central Weights and Measures Association

At the 2023 CWMA Interim Meeting, no comments were heard. The Committee recommends this item be Informational for more comments to come in.

Southern Weights and Measures Association

At the 2024 SWMA Annual Meeting, they recommend a Developing status for this item and would like the following areas of concern to be addressed:

- Additional safety concerns when handling dry ice (OSHA requirements)
- Costs associated to the test method (specifically dry ice and equipment)
- Additional data from other states (i.e., repeatability)
- Applicability to other states
- Address other ice creams products not included in the definition of novelty.

Northeastern Weights and Measures Association

At the 2023 NEWMA Interim Meeting, Marc Paquette (Vermont) has received complaints involving short measure, very difficult testing procedures. The item needs to address the use of kerosene in the

testing protocol (remove it). Walt Remmert (Pennsylvania) agrees this should stay as developing. Jim Willis (New York) related that it is a very messy procedure that can't be done on site in stores.

NET-24.2 Section 4.9. Procedure for Checking the Contents of Specific Agriculture Seed Packages Labeled by Count., and Appendix D. AOSA Rules for Testing Seeds.

Source: Louisiana Department of Agriculture and Forestry

Submitter's Purpose and Justification:

Align Chapter 4.9. Procedure for Checking the Contents of Specific Agriculture Seed Packages Labeled by Count and Appendix D. AOSA Rules for Testing Seeds with recent changes to Association of Official Seed Analyst (AOSA) Rules.

The primary purpose of this proposal is to clarify that the mechanical seed counting process (outlined in AOSA Rules Vol.1 Section 12) may be used to determine the number of seeds contained in a sample of additional crop kinds not listed. The mechanical seed counter must be proven it is fit for purpose (suitable) for seed kinds not listed, by using a 1,000 seed calibration sample of the seed kind under consideration. This proposal would provide a standardized mechanical seed counter calibration procedure for all models of mechanical seed counters being used across the United States, to determine the number of seeds per pound and/or for the purpose of packaging seeds by count.

The submitter acknowledged the following:

- 1) Some mechanical seed counters have an automatic calibration feature that allows the device to automatically adjust the settings to accurately count the seeds. Thus, there is no need to require mechanical seed counters to be calibrated and/or verified using a 1,000 seed calibration sample.
- 2) AOSA Rules Volume 1 Section 14.9 only has maximum tolerances for comparing two seed count test results for corn, field bean, soybean, and wheat. Two mechanical seed counts for seed kinds not listed cannot be compared since there are no tolerances. Thus, there is no need to require mechanical seed counters to be calibrated using a 1,000 seed calibration sample to confirm if the counter is suitable for use for kinds of seeds not listed in Section 14.9

Seed Counter 1000 Seed Calibration Verification Record

| Date | Technician Initials | Crop | Feeder Fast | Feeder Slow | Sensitivity* | Length Rejection* | Count | Pass Y/N (± 2 seeds) | Comments |
|-----------|---------------------|--------|-------------|-------------|--------------|-------------------|-------|-------------------------|-------------------------|
| 28-Dec-22 | DMJ | Cotton | 2.2 | 7.8 | High 3 | 2 | 1000 | y | Calib. sample confirmed |
| 28-Dec-22 | DMJ | Cotton | 2.2 | 7.8 | High 3 | 2 | 1001 | y | |
| 28-Dec-22 | DMJ | Cotton | 2.2 | 7.8 | High 3 | 2 | 1000 | y | |
| 28-Dec-22 | DMJ | Cotton | 2.2 | 7.8 | High 3 | 2 | 1000 | y | |
| 28-Dec-22 | DMJ | Cotton | 2.2 | 7.8 | High 3 | 2 | 999 | y | |
| 28-Dec-22 | DMJ | Cotton | 2.2 | 7.8 | High 3 | 2 | 996 | n | Calib. sample confirmed |
| 28-Dec-22 | DMJ | Cotton | 2.2 | 7.8 | High 3 | 2 | 999 | y | |
| 28-Dec-22 | DMJ | Cotton | 2.2 | 7.8 | High 3 | 2 | 999 | y | |
| 28-Dec-22 | DMJ | Cotton | 2.2 | 7.8 | High 3 | 2 | 999 | y | |
| 28-Dec-22 | DMJ | Cotton | 2.2 | 7.8 | High 3 | 2 | 1000 | y | |
| | | | | | | | | | |
| | | | | | | | | | |
| | | | | | | | | | |
| | | | | | | | | | |
| | | | | | | | | | |
| | | | | | | | | | |
| | | | | | | | | | |
| | | | | | | | | | |
| | | | | | | | | | |
| | | | | | | | | | |
| | | | | | | | | | |
| | | | | | | | | | |
| | | | | | | | | | |
| | | | | | | | | | |
| | | | | | | | | | |
| | | | | | | | | | |
| | | | | | | | | | |
| | | | | | | | | | |
| | | | | | | | | | |
| | | | | | | | | | |
| | | | | | | | | | |

*Note: Sensitivity and Length Rejection settings located inside of top access panel.

- Procedure:**
- >Ensure all counter setting are on the appropriate set points for the crop being counted
 - >Carefully pour the 1,000 seed calibration sample of the crop being counted into seed counter bowl
 - >Start counter and run until all seeds have been counted
 - >Record number of seeds as displayed on counter display and any additional seeds remaining in bowl
 - >Calibration count should not vary more than ±2 seeds from the 1,000 seed calibration sample
 - >If count is not within the tolerance, check settings, clean appropriate areas of the counter
 - >Rerun calibration sample up to 3 times to confirmed that the counter may not be working appropriately
 - >If count is not within the ±2 seed tolerance then manually count calibration sample to confirm 1,000 seeds
 - >If calibration sample does not contain 1000 seeds, adjust as needed by adding or removing seeds
 - >If calibration sample is correct, adjust speed and/or sensitivity settings until ±2 seed tolerance is obtained
 - >If seed counter continues to fail calibration check, do not use until counter has been repaired and then verified using the 1,000 seed calibration sample

Seed Counter 1000 Seed Calibration Verification Record

IMD Model 750-2CS

v23MAR2018

| Date | Technician Initials | Crop | Feeder Fast | Feeder Slow | Sensitivity* | Length Rejection* | Count | Pass Y/N (± 2 seeds) | Comments |
|-----------|---------------------|------|-------------|-------------|--------------|-------------------|-------|----------------------|-------------------------|
| 28-Dec-22 | DMJ | Hemp | 2.0 | 7.0 | High 4 | 2 | 1001 | y | Calib. sample confirmed |
| 28-Dec-22 | DMJ | Hemp | 2.0 | 7.0 | High 4 | 2 | 1000 | y | |
| 28-Dec-22 | DMJ | Hemp | 2.0 | 7.0 | High 4 | 2 | 998 | y | |
| 28-Dec-22 | DMJ | Hemp | 2.0 | 7.0 | High 4 | 2 | 998 | y | |
| 28-Dec-22 | DMJ | Hemp | 2.0 | 7.0 | High 4 | 2 | 998 | y | Calib. sample confirmed |
| 28-Dec-22 | DMJ | Hemp | 2.0 | 7.0 | High 4 | 2 | 1000 | y | |
| 28-Dec-22 | DMJ | Hemp | 2.0 | 7.0 | High 4 | 2 | 999 | y | |
| 28-Dec-22 | DMJ | Hemp | 2.0 | 7.0 | High 4 | 2 | 1000 | y | |
| 28-Dec-22 | DMJ | Hemp | 2.0 | 7.0 | High 4 | 2 | 1000 | y | |
| 28-Dec-22 | DMJ | Hemp | 2.0 | 7.0 | High 4 | 2 | 1000 | y | |
| | | | | | | | | | |
| | | | | | | | | | |
| | | | | | | | | | |
| | | | | | | | | | |
| | | | | | | | | | |
| | | | | | | | | | |
| | | | | | | | | | |
| | | | | | | | | | |
| | | | | | | | | | |
| | | | | | | | | | |
| | | | | | | | | | |
| | | | | | | | | | |
| | | | | | | | | | |
| | | | | | | | | | |
| | | | | | | | | | |
| | | | | | | | | | |
| | | | | | | | | | |
| | | | | | | | | | |
| | | | | | | | | | |
| | | | | | | | | | |
| | | | | | | | | | |
| | | | | | | | | | |
| | | | | | | | | | |
| | | | | | | | | | |

*Note: Sensitivity and Length Rejection settings located inside of top access panel.

Procedure:
 >Ensure all counter setting are on the appropriate set points for the crop being counted
 >Carefully pour the 1,000 seed calibration sample of the crop being counted into seed counter bowl
 >Start counter and run until all seeds have been counted
 >Record number of seeds as displayed on counter display and any additional seeds remaining in bowl
 >Calibration count should not vary more than ±2 seeds from the 1,000 seed calibration sample
 >If count is not within the tolerance, check settings, clean appropriate areas of the counter
 >Rerun calibration sample up to 3 times to confirmed that the counter may not be working appropriately
 >If count is not within the ±2 seed tolerance then manually count calibration sample to confirm 1,000 seeds
 >If calibration sample does not contain 1000 seeds, adjust as needed by adding or removing seeds
 >If calibration sample is correct, adjust speed and/or sensitivity settings until ±2 seed tolerance is obtained
 >If seed counter continues to fail calibration check, do not use until counter has been repaired and then verified using the 1,000 seed calibration sample

Seed Counter 1000 Seed Calibration Verification Record

IMD Model 750-2CS v23MAR2018

| Date | Technician Initials | Crop | Feeder Fast | Feeder Slow | Sensitivity* | Length Rejection* | Count | Pass Y/N (± 2 seeds) | Comments |
|-----------|---------------------|------|-------------|-------------|--------------|-------------------|-------|---------------------------|-------------------------|
| 28-Dec-22 | DMJ | Rice | 2.2 | 7.0 | High 3 | 2 | 1000 | y | Calib. sample confirmed |
| 28-Dec-22 | DMJ | Rice | 2.2 | 7.0 | High 3 | 2 | 998 | y | |
| 28-Dec-22 | DMJ | Rice | 2.2 | 7.0 | High 3 | 2 | 1000 | y | |
| 28-Dec-22 | DMJ | Rice | 2.2 | 7.0 | High 3 | 2 | 1000 | y | |
| 28-Dec-22 | DMJ | Rice | 2.2 | 7.0 | High 3 | 2 | 1000 | y | |
| 28-Dec-22 | DMJ | Rice | 2.2 | 7.0 | High 3 | 2 | 1000 | y | |
| 28-Dec-22 | DMJ | Rice | 2.2 | 7.0 | High 3 | 2 | 998 | y | |
| 28-Dec-22 | DMJ | Rice | 2.2 | 7.0 | High 3 | 2 | 1000 | y | |
| 28-Dec-22 | DMJ | Rice | 2.2 | 7.0 | High 3 | 2 | 1001 | y | |
| 28-Dec-22 | DMJ | Rice | 2.2 | 7.0 | High 3 | 2 | 1001 | y | |
| | | | | | | | | | |
| | | | | | | | | | |
| | | | | | | | | | |
| | | | | | | | | | |
| | | | | | | | | | |
| | | | | | | | | | |
| | | | | | | | | | |
| | | | | | | | | | |
| | | | | | | | | | |
| | | | | | | | | | |
| | | | | | | | | | |
| | | | | | | | | | |
| | | | | | | | | | |
| | | | | | | | | | |
| | | | | | | | | | |
| | | | | | | | | | |
| | | | | | | | | | |
| | | | | | | | | | |

**Note: Sensitivity and Length Rejection settings located inside of top access panel.*

Procedure:

- >Ensure all counter setting are on the appropriate set points for the crop being counted
- >Carefully pour the 1,000 seed calibration sample of the crop being counted into seed counter bowl
- >Start counter and run until all seeds have been counted
- >Record number of seeds as displayed on counter display and any additional seeds remaining in bowl
- >Calibration count should not vary more than ± 2 seeds from the 1,000 seed calibration sample
- >If count is not within the tolerance, check settings, clean appropriate areas of the counter
- >Rerun calibration sample up to 3 times to confirmed that the counter may not be working appropriately
- >If count is not within the ± 2 seed tolerance then manually count calibration sample to confirm 1,000 seeds
- >If calibration sample does not contain 1000 seeds, adjust as needed by adding or removing seeds
- >If calibration sample is correct, adjust speed and/or sensitivity settings until ± 2 seed tolerance is obtained
- >If seed counter continues to fail calibration check, do not use until counter has been repaired and then verified using the 1,000 seed calibration sample

Mechanical Seed Counters Operation Manual Review:

The following mechanical seed counter information and operational manuals were briefly reviewed to determine if a 1,000 seed calibration sample was required or encouraged to be used to calibrate the device. While a few devices stated they had an automatic calibration and/or adjustment process, none of the manuals stated using a 1,000 seed calibration sample to confirm the accuracy of the device before use.

1. Wintersteiger Seed Counter S-25+ – <https://www.wintersteiger.com/us/Plant-Breeding-and-Research/Products/Product-range/Laboratory-preparation/66-Seed-Count-S-25plus>



2. Agri-Instrument SLY-E High Accuracy Automatic Seed Counter - <https://www.agri-instrument.com/wp-content/uploads/2018/05/SLY-E-High-Accuracy-Automatic-Seed-Counter.pdf>

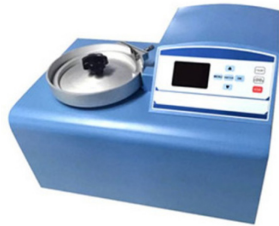

3. Data Technologies DATA Count S-25 Plus - <https://data-technologies.com/wp-content/uploads/2017/09/Seed-Counter-S-25.pdf>



4. Seedbuero Count-A-Pak 801 - https://cdn.shopify.com/s/files/1/0070/8041/1191/files/801_Manual.pdf?v=1614276180



5. International Marketing and Design (IMD) Technologies Totalizer 750-2 C Series - <http://www.seedcounters.com/index.php/counting/summary?id=148>

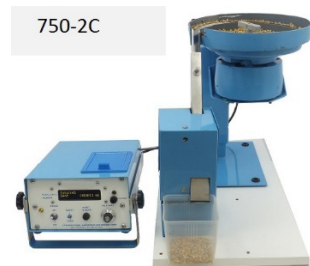

6. Pfeuffer Contador - <https://www.pfeuffer.com/product/contador>



| |
|--|
| NIST OWM Executive Summary for NET-24.2 – Section 4.9. Procedure for Checking the Contents of Specific Agriculture Seed Packages Labeled by Count., and Appendix D. AOSA Rules for Testing Seeds. |
| <p>NIST OWM Recommendation: OWM recommends a status of Voting.</p> <ul style="list-style-type: none"> NIST OWM believes this aligns with the Association of Official Seed Analyst (AOSA) test method and will update NIST Handbook 133 Appendix D. AOSA Rules for Testing Seeds to reflect the most updated version of the AOSA document. Appendix D. AOSA Rules for Testing Seeds is a document provided by the Association of Official Seed Analyst https://analyzeseeds.com/. On November 14, 2023, NIST OWM received copyright permission to reprint the matter into NIST Handbook 133 and AOSA has forwarded the matter to NIST OWM for inclusion if adopted. |

**Table 2. Summary of Recommendations
NET-24.2 – Section 4.9. Procedure for Checking the Contents of Specific Agriculture Seed Packages Labeled by Count., and Appendix D. AOSA Rules for Testing Seeds.**

| | Status Recommendation | Note* | Comments |
|-----------|-----------------------|-------|----------|
| Submitter | | | |
| OWM | Voting | | |
| WWMA | Informational | | |
| NEWMA | Voting | | |

| | | | |
|------|---------------|--|--|
| SWMA | Voting | | |
| CWMA | Informational | | |
| NCWM | | | |

***Notes Key:**

- 1 Submitted modified language
- 2 Item not discussed
- 3 No meeting held
- 4 Not submitted on agenda
- 5 No recommendation or not considered.

Item Under Consideration:

Amend Handbook 133, Checking the Net Contents of Packaged Goods, as follows:

4.9. Procedure for Checking the Contents of Specific Agriculture Seed Packages Labeled by Count

The following method shall be employed when using a mechanical seed counter to determine the number of seeds contained in a sample of soybean (*Glycine max*), corn (*Zea mays*), wheat (*Triticum aestivum*) and field bean (*Phaseolus vulgaris*) **and other seeds kinds. CAUTION: A mechanical seed counter may not be appropriate to use for counting all seed kinds.**

...

4.9.2. Test Procedure

1. Testing samples shall be received and retained in moisture proof containers until the weight of the sample prepared for purity analysis is recorded. The sample shall be of at least 500 grams for soybean, **and** field beans, and 100 grams for wheat. **The sample weight for other seed kinds being tested shall be the weight of the purity exam listed in AOSA Rules Volume 1 Table 2A.**

and

Appendix D. AOSA Rules for Testing Seeds

SECTION 12: MECHANICAL SEED COUNT

The following method shall be employed when using a mechanical seed counter to determine the number of seeds contained in a sample of soybean (*Glycine max*), corn (*Zea mays*), wheat (*Triticum aestivum*) and field bean (*Phaseolus vulgaris*) **and other seeds kinds. CAUTION: A mechanical seed counter may not be appropriate to use for counting all seed kinds.**

12.1 Samples

Samples for testing shall be of at least 500 grams for soybean, corn and field beans and 100 grams for wheat. **The sample weight for other seed kinds being tested shall be the weight of the purity exam listed in AOSA Rules Volume 1 Table 2A, and All samples shall be** received in moisture proof

containers. Samples shall be retained in moisture proof containers until the weight of the sample prepared for purity analysis is recorded.

12.2 Seed counter calibration

...

- (b) Carefully pour the 1,000 seed calibration sample into the seed counter. Start the counter and run it until all the seeds have been counted. The seeds should not touch as they run through the counter. Record the number of seeds as displayed on the counter read out. The seed count should not vary more than ± 2 seeds from 1,000. If the count is not within this tolerance, clean the mirrors, adjust the feed rate and/or reading sensitivity. Rerun the calibration sample until it is within the ± 2 seed tolerance. If the seed counter continues to fail the calibration procedure and the calibration sample has been checked to ensure that it contains 1,000 seeds, do not use the counter until it has been repaired. and then verified using the 1,000 seed calibration sample.

CAUTION: If the 1,000 seed calibration sample for a non-listed seed kind being counted always varies more than the permitted ± 2 seeds from 1,000, then the use of the mechanical seed counter is not appropriate for that seed kind and must not be used for counting.

NIST OWM Detailed Technical Analysis:

NIST OWM believes this aligns with the Association of Official Seed Analyst (AOSA) test method and will update NIST Handbook 133 Appendix D. AOSA Rules for Testing Seeds to reflect the most updated version the AOSA document.

On November 14, 2023, NIST OWM received copyright permission to reprint the matter into NIST Handbook 133 and AOSA has forwarded the matter to NIST OWM for inclusion if adopted.

Summary of Discussions and Actions

Regional Association Reporting:

Western Weights and Measures Association

At the 2023 WWMA Annual Meeting, Matt Douglas (California Department of Food and Agriculture, Division of Measurement Standards) was not familiar with the testing procedure but was not against the proposal. Matt was hoping for more discussion on this proposal.

The WWMA recommends this item be Informational.

Central Weights and Measures Association

At the 2023 CWMA Interim Meeting, no comments were heard. The Committee recommends this item be Informational for more comments to come in.

Southern Weights and Measures Association

At the 2023 SWMA Annual Meeting, they recommend a Voting status for this item pending copyright approval to be included into NIST HB 133.

Northeastern Weights and Measures Association

At the 2023 NEWMA Interim Meeting, Jim Willis (New York) stated they have a seed lab and the director of this lab is in favor of this being a voting item. Walt Remmert (Pennsylvania) concurs with New York. Lou Sakin (Holliston, Massachusetts) recommends it move forward as Voting item.

OTH – Other Items

OTH-24.1 X. Uniform Shipping Law

Source: New Hampshire Department of Agriculture, Markets & Food

Submitter’s Purpose and Justification:

Provide model law language to address the shipment of goods.

Current shipping practices may result in incorrect overcharges and misleading pricing. It has been documented through investigations that carriers or freight brokers have incorrectly billed shippers on goods shipped. Documentation provided by carriers to both shippers and weights and measures officials lack relevant information needed to fully investigate complaints within the shipping industry.

Carriers may have language in their contracts that inform the shipper of possible audits of their shipped goods and subsequent correction and audit fees.

The submitter requested Voting status in 2024.

| NIST OWM Executive Summary for OTH-24.1 – X, Uniform Shipping Law |
|---|
| <p>NIST OWM Recommendation: OWM believes this item be Assigned to a Task Group to develop. The submitter remarked at the 2023 NEWMA Interim Meeting they would be willing to participate or Chair a Task Group.</p> <ul style="list-style-type: none">• NIST OWM has applied the appropriate formatting according to NIST Handbooks. |

**Table 2. Summary of Recommendations
OTH-24.1 – X, Uniform Shipping Law**

| | Status Recommendation | Note* | Comments |
|-----------|-----------------------|-------|----------|
| Submitter | Voting | | |
| OWM | Assigned | | |
| WWMA | Informational | | |
| NEWMA | Developing | | |
| SWMA | Withdrawn | | |
| CWMA | Withdrawn | | |
| NCWM | | | |

***Notes Key:**

- 1 Submitted modified language
- 2 Item not discussed
- 3 No meeting held
- 4 Not submitted on agenda
- 5 No recommendation or not considered

Item Under Consideration:

(NIST OWM has applied the appropriate formatting according to NIST Handbooks)

Adopt a new Handbook 130, Uniform Shipping Law as follows:

X. Uniform Shipment Law

Section 1. Purpose

The purpose of this Act is to ensure the accurate shipment of goods.

Section 2. Scope

This Act:

- (a) establishes an enforcement program;**
- (b) empowers the state to promulgate regulations as needed to carry out the provisions of the Act;**
- (c) provides for civil and criminal penalties.**

Section 3. Definitions

As used in this Act:

3.X. Goods. – All things which are movable and can be transported.

3.X. Carrier. – The business that transports an amount of goods.

3.X Shipper. – Individuals or businesses that send goods using a carrier.

3.X. Shipment. – A quantity of goods shipped with a carrier.

3.X. Freight. – Goods or charges.

3.X. Freight Broker. – The intermediary between the shipper and the carrier who facilitates the transportation of goods.

3.X. Quote. – A competitively solicited written offer to furnish supplies or services by a method of procurement that is less formalized than a bid or a proposal.

3.X. Bill of Lading (BOL). – A legal instrument used in the transportation and shipping industries which lists the goods being shipped and the terms under which they will be delivered.

3.X. Progressive Number (Pro Number). – A series of numbers used by carriers to identify and then track a specific order tendered to a specific carrier.

3.X. Inspection Certificate. – A document used to signify that shipped goods have been inspected pertaining, but not limited to, classification, density, weight, or measure.

3.X. Director. – The _____ of the Department of _____.

Section 4. Enforcing officer: Rules and Regulations

The Director is authorized to:

- (a) enforce the provisions of this Act;**
- (b) issue reasonable regulations for the enforcement of this Act that shall have the force and effect of law; and**
- (c) adopt rules that include, but are not limited to;**
 - (1) adherence to quotes when correct documentation is provided to the carrier;**
 - (2) weighing and measuring practices that must be followed;**
 - (3) the required information to be submitted to the shipper if there is a correction fee applied; and**
 - (4) the period of recordkeeping.**

Section 5. Weighing and Measuring Practices and Equipment Used

A carrier shall use the following weighing and measuring practices and equipment:

(a) in accordance with the requirements of the latest edition of NIST Handbook 44, “Specifications, Tolerances, and Other Technical Requirements for Weighing and Measuring Devices”; and

(b) examined, tested, and approved for use by a weights and measures officer of this state.

Section 6. Weighing Device Used:

A carrier shall use a scale in accordance with the manufacturer’s approved application of the device.

Section 7. Measuring Device Used:

A carrier shall use a measuring device in accordance with the manufacturer’s approved application of the device.

Section 8. Inspection Certificate: Required Entries

- (a) The documentation, when properly completed and signed shall be prima facie evidence of the accuracy of the procedure followed and the recorded results.**
- (b) The design of and the information to be furnished on the documentation shall be prescribed by the Director and will include, but not be limited to, the following:**
 - (1) the name and employee ID# of the individual who conducts the inspection;**
 - (2) date and time of the inspection;**
 - (3) signature of the employee who conducts the inspection (digital signature accepted);**
 - (4) identifying information of the weighing or measuring device used to conduct the inspection to include the associated make, model, serial number, and Certificate of Conformance number, if applicable;**
 - (5) indicated reweigh or remeasure value from the weighing device or measuring device;**
 - (6) provide detailed information on the process used to reclassify a shipment according to type of goods and/or shipment density;**
 - (7) provide the dollar amount of the correction fee applied and the description of the fee;**
 - (8) identifying information for the issuing terminal to include physical address and contact name of terminal manager to include phone number and/or email address;**
 - (9) identifying information for both the Pro Number and BOL, if applicable;**
 - (10) the name and address of the shipper from point of origin;**

- (11) the tendered classification, density, weight, or measurement provided from the shipper and freight broker, if applicable; and
- (12) the declared classification, density, weight, or measurement determined by the carrier and freight broker, if applicable.

Section 9. Copies of Inspection Certificates

The carrier shall keep and preserve for the period specified in the regulations a legible copy of each inspection certificate issued to the shipper and freight broker, if applicable. The certificates shall be available for inspection by any weights and measures officer during normal office hours.

Section 10. Prohibited Acts

No entity shall

- (a) provide a false classification, density, weight, or measurement;
- (b) violate any provisions of this Act or any regulation promulgated under this Act; or
- (c) use or have in their possession a device which has been altered to facilitate fraud.

Section 11. Civil Penalties

11.1. Assessment of Penalties. – Any entity who by themselves or by their servant or agent commits any of the acts enumerated in Section 14. Validity of Prosecutions may be assessed by the a civil penalty of:

- (a) not less than \$ nor more than \$ for a first violation,
- (b) not less than \$ nor more than \$ for a second violation within from the date of the first violation, and
- (c) not less than \$ nor more than \$ for a third violation within from the date of the first violation.

11.2. Administrative Hearing. – Any entity subject to a civil penalty shall have a right to request an administrative hearing within _____ days of receipt of the notice of the penalty. The Director or their designee shall be authorized to conduct the hearing after giving appropriate notice to the respondent. The decision of the Director shall be subject to appropriate judicial review.

11.3. Collection of Penalties. – If the respondent has exhausted their administrative appeals and the civil penalty has been upheld, they shall pay the civil penalty within _____ days after the effective date of the final decision. If the respondent fails to pay the penalty, a civil action may be brought by the Director in any court of competent jurisdiction to recover the penalty. Any civil penalty collected under this Act shall be transmitted to _____.

Section 12. Criminal Penalties

12.1. Misdemeanor. – Any entity who by themselves or by their servant or agent commits any of the acts enumerated in Section 10. Prohibited Acts or violates any other provision of this Act shall be guilty of a Class _____ misdemeanor and upon conviction shall be punished by a fine not less than \$ _____, nor more than \$ _____, or by imprisonment for not less than _____ nor more than _____, or both fine and imprisonment.

12.2. Felony. – Any entity who by themselves or their servant or agent who intentionally commits any of the acts enumerated in Section 1. Prohibited Acts or repeatedly violates any other provision of this Act shall be guilty of a Class _____ felony and upon conviction shall be punished by a fine not less than \$ _____ and/or by imprisonment for not less than _____, nor more than _____.

Section 13. Restraining Order and Injunction

The Director is authorized to apply to any court of competent jurisdiction for a restraining order, or a temporary or permanent injunction, restraining any person from violating any provision of this Act.

Section 14. Validity of Prosecutions

Prosecutions for violation of any provision of this Act are declared to be valid and proper notwithstanding the existence of any other valid general or specific Act of this state dealing with matters that may be the same as or similar to those covered by this Act.

Section 15. Severability Provision

If any provision of this Act is declared unconstitutional, or the applicability thereof to any person or circumstance is held invalid, the constitutionality of the remainder of the Act and the applicability thereof to other persons and circumstances shall not be affected.

Section 16. Repeal of Conflicting Laws

All laws and parts of laws contrary to or inconsistent with the provisions of this Act, and specifically _____, are repealed insofar as they might operate in the future; but as to offenses committed, liabilities incurred, and claims now existing there under, the existing law shall remain in full force and effect.

Section 17. Citation

This Act may be cited as the “Shipment Act of _____.”

Section 18. Effective Date

This Act shall become effective on _____.

NIST OWM Detailed Technical Analysis:

NIST OWM believes this item has merit and recommends the NCWM L&R Committee form a NCWM Task Group that is Chaired by the submitter, Cheryl Ayer. The goals of the Task Group should be to identify any other regulations that this proposal might infringe upon, as an example, the Federal Motor Carrier regulations of the Department of Transportation. We strongly encourage the Task Group to do an in-depth review of interstate commerce.

Summary of Discussions and Actions

Regional Association Reporting:

Western Weights and Measures Association

At the 2023 WWMA Annual Meeting, Steven Harrington (State of Oregon) had no preference in opposition or support for this item. Steve Harrington stated we might run into a situation where we are getting into regulating interstate commerce, so this item needs to be vetted, possibly by a Task Group, to ensure we get the details right.

Matt Douglas (California Department of Food and Agriculture, Division of Measurement Standards) echoed Steven Harrington's comments, with the additional statement that more input would be needed from impacted industries and may need to be addressed by a Task Group. Matt Douglas stated this should be a Developing item.

Kurt Floren (Los Angeles County, California) echoed previous speakers, adding that there has been fraud for many, many years in this area, particularly in the moving industry, with no record of re-weighments, and possessions being held hostage, so it would seem that something needs to be done. However, this would be stepping heavily into interstate commerce with little justification. They stated there needs to be additional justification, and recommends this item be Informational and to call for broad nationwide input.

The WWMA recommends this item be Informational.

Central Weights and Measures Association

At the 2023 CWMA Interim Meeting, Mike Harrington (Iowa) commented they do not fully understand the purpose of this item and asked for clarification from the submitter. At this point they would recommend withdrawing the item because they don't understand how it relates to weights and measures.

The Committee recommends withdrawal. More information is needed to clarify the intent of this item.

Southern Weights and Measures Association

At the 2023 SWMA Annual Meeting, the SWMA L&R Committee does not see any merit in the language as provided and recommends this item be Withdrawn.

Northeastern Weights and Measures Association

At the 2023 NEWMA Interim Meeting, Cheryl Ayer (New Hampshire and submitter) provided a presentation and PowerPoint. The expectation is to create rules for shipping (and reweighing) products nationwide. Cheryl is willing to participate or chair a task group. Walt Remmert (Pennsylvania) recognizes this is a problem and thanks New Hampshire for taking on this issue. Pennsylvania supports the item and has a volunteer to work on the Task Group if one is organized. Lou Sakin (Holliston, Massachusetts) commends New Hampshire for her presentation. They question if this is an interstate commerce issue and which agencies need to get involved? Seeking help from other jurisdictions for input and help with these issues. Perhaps a task group is appropriate. Jason Flint (New Jersey) likes the idea and wants it to be further developed.

OTH-07.1 D Fuels and Lubricants Subcommittee

Source: NCWM Fuels and Lubricants Subcommittee (FALS)

Submitter's Purpose and Justification:

For more information or to provide comment, please contact the FALS Chair:

Vanessa Benchea
Florida Department of Agriculture and Consumer Services / Division of Consumer Services
(813) 868-8263, Vanessa.Benchea@fdacs.gov

Summary of Discussions and Actions:

This item is to provide a report on the activities of the Fuels and Lubricants Subcommittee (FALS) which reports and provides recommendations to the Laws and Regulations Committee.

FALS met at the 2023 NCWM Interim Meeting to review items related to fuel and automotive fluid standards that appear on the L&R agenda. A brief update received from IFG Chair Johnson who is working on Item Block 6, an item currently assigned to FALS, was presented to the Subcommittee. There were also brief discussions of Item Block 1, Block 2, as well as FLR-23.3 and FLR-23.4.

FLR-23.3 Section 2.20 Hydrogen Fuel: At the 2023 NCWM Interim Meeting, the proposed change to this section would add an additional standard, ISO 14687 Grade (D) "Hydrogen fuel quality – Product specification", which could cause some difficulty for regulators to adopt and cause confusion as to which standard to follow since there could be "Harmonization Gap" between the two referenced standards when they are not aligned. The consensus from the group was that there was agreement that one standard should be referenced, and that stakeholders and suppliers should be consulted for direction on which standard was more appropriate. Kevin Schnepf recommended Informational status and suggested getting input from other OEMs and industry members. Lisa Warfield (OWM) clarified that Grade D would be specific to road vehicles only.

FALS Standard Operating Procedures: At the 2023 NCWM Interim Meeting discussion of old business was presented. Kristi Moore (Growth Energy) requested a status update of the FALS Standard Operation Procedures (SOP). Bill Striejewski (previous FALS Chair) stated that recommendations and changes discussed at the FALS meeting held at the 2022 NCWM Annual meeting had been incorporated

and is now the current version which will be posted to the website for the FALS to view. There was also clarification that the FALS can continue to operate under this SOP and this item will be removed from the Board of Director's agenda.

At the 2023 NCWM Annual Meeting, FALS met review items related to fuel and automotive fluid standards that appear on the L&R agenda. Updates were provided for assigned Item Block 1 and 6. They discussed proposed changes to Item Block 2 and discussed and two new business items related to drag reducing agents in retail diesel and NIST formatting standards when referencing citations from Federal Government Agencies.

Item Block 1 (B1) Renewable Diesel and Diesel: At the 2023 NCWM Interim Meeting, Chuck Corr gave a presentation on this item and during his discussion with the FALS they presented a holistic approach should be taken in this endeavor and that he intends to lead an IFG to review all of HB 130 with the goal of the harmonizing the definitions of middle distillates. Shailesh Lopes (General Motors) encouraged any work group include labeling considerations when determining definitions.

At the 2023 NCWM Annual Meeting, Chuck Corr provided the latest developments that there were additional changes from the language in Publication 16 that resulted from a IFG meeting. Further there were changes that were made based on input from comments submitted following the IFG meeting. The IFG is on hiatus until after the fall Regional Association meetings. The IFG will reconvene and discuss any changes that may be needed and present this at the NCWM 2024 Interim Meeting

Jim Rocco, (Sage Risk, for Energy Marketers of America) introduced the discussion on how the definitions of biomass-based diesel and biodiesel should be managed. Chuck Corr indicated the intention of the IFG was to be consistent with the FTC motor fuel rating requirements as well as ASTM where possible. Jim Rocco asked how industry uses the specifications for diesel, making the point that the NCWM body needs to ensure that we are consistent and not confusing with FTC and ASTM.

Shailesh Lopes (General Motors) suggested that the biomass-based diesel was commonly known as renewable diesel and asked that the presentation include a note to that effect. Others agreed that would be a good addition. Russ Lewis (Marathon Petroleum) asked for the final version to be shared with the Committee for discussion. While there was no consensus around some of the language presented, there was ultimately consensus by FALS that it was ready to be advanced at the Regional Associations.

New Business: At the 2023 NCWM Annual Meeting, Joanna Johnson recommended that a new group be started that focuses on EV fluids and EV transmission fluids from gear oil. There was no opposition from FALS for this new task.

Brian Kernke (Love's Travel Stores) presented information on the impacts that unsheared drag reducing agents have had on Love's business and stated that there had also been impacts at retail stations as well as truck drivers. He indicated it was expensive to replace filters and the associated downtime at retail. Bill Striejewske (Nevada) indicated that they had seen these issues in Nevada and that it was causing dispensers to flow so slow that shutoffs weren't working properly.

Chuck Corr spoke on the proposed NIST established editorial standards. He has concerns about including the year. Lisa Warfield (NIST OWM Advisor) commented that listing a year would be up to NCWM, but the handbooks will not list a year; it will be simply up to date with the latest CFR standard format for publications. Jim Rosso and Steven Harrington (Oregon) both believe a date should not be listed. There was agreement from FALS that would agree with the NIST format standard (Name, Volume Source § xxx (Year)). Feedback from FALS Chair to the Board of Directors will request no dates be included when

referencing citations from federal government agencies. Lisa Warfield noted that this was presented to the Board of Directors in May 2023 and they had already approved making the changes to the handbooks.

OTH-11.1 D Packaging and Labeling Subcommittee

Source: NCWM Packaging and Labeling Subcommittee (PALS)

Submitter's Purpose and Justification:

Provide an update of the activities of this Subcommittee which reports to the L&R Committee. The mission of PALS is to assist the L&R Committee in the development of agenda item, NCWM positions and new standards related to packaging and labeling. The Subcommittee will also be called upon to provide important and much needed guidance to the regulatory and consumer packaging communities on difficult questions. PALS will report to NCWM L&R Committee. The Subcommittee is comprised of a Chair, eight voting members, and anyone interested in packaging and labeling standards.

This item is to provide a report on the activities of the PALS which reports and provides recommendations to the Laws and Regulations Committee.

For more information or to provide comment, please contact the PALS Chair:

Chris Guay (CGGT)
(513) 652-6597, guay.cb@gmail.com

Summary of Discussions and Actions:

At the 2023 CWMA Interim Meeting, Chair Guay provided an activity update and invited interested attendees to be active members of the Committee. Chair Guay reported PALS is working on a supplemental Identity document which should be available in January. The Committee recommends this remain Developing.

Item Block 1 (B1) Renewable Diesel and Diesel

- B1: MOS-23.1 A Sections 2.31. Biodiesel and biodiesel Blends that Contain Greater Than or Equal to 21 % by Volume Biodiesel. and 2.40. Diesel Fuel.
- B1: FLR-23.1 A Sections 1.9. Biodiesel Blend., 1.27. Fuel Oil., 1.XX. Renewable Diesel., 3.3.2. Automotive Fuel Rating., 3.15. Biodiesel and Biodiesel Blends Containing Greater than 20 % by Volume Biodiesel.

(NOTE: The language as reflected in the Item Under Consideration was submitted by FALS to the L&R Committee on December 12, 2023. This supporting document also appears on the NCWM L&R Supporting Documents website.)

Source: CC Consulting, LLC

Submitter’s Purpose and Justification:

Further refine and provide clarity to the changes related to biodiesel made at the 2022 NCWM Annual meeting. This proposal also includes needed updates related to renewable diesel. The proposal also includes important information related to renewable diesel. The submitter recognizes that some may think no changes are needed.

| NIST OWM Executive Summary for Item Block 1 (B1) –Renewable Diesel and Diesel |
|--|
| <p>NIST OWM Recommendation: NIST OWM recommends this Item remain Assigned.</p> <ul style="list-style-type: none"> • The “Source” should be changed from CC Consulting, LLC to reflect that it is currently assigned to “FALS”. • NIST OWM recognizes that FALS met on December 12, and the Item Under Consideration in the NIST OWM Analysis reflects the latest language submitted to the L&R Committee. |

**Table 2. Summary of Recommendations
 Item Block 1 (B1) – Section 10. Certificate: Required Entries**

| | Status Recommendation | Note* | Comments |
|-----------|------------------------------|--------------|-----------------|
| Submitter | | | |
| OWM | Assigned | | |
| WWMA | Assigned | | |
| NEWMA | Developing | | |
| SWMA | Assigned | | |
| CWMA | Assigned | | |
| NCWM | | | |

***Notes Key:**

- 1 Submitted modified language
- 2 Item not discussed
- 3 No meeting held
- 4 Not submitted on agenda
- 5 No recommendation or not considered

Item Under Consideration:

(NIST OWM has applied the appropriate formatting according to NIST Handbooks)

Amend Handbook 130, Uniform Regulation for the Method of Sale of Commodities as follows:

B1: MOS-23.1 Sections 2.31. Biodiesel and biodiesel Blends that Contain Greater Than or Equal to 21 % by Volume Biodiesel and 2.40. Diesel Fuel.

2.31. Biodiesel and Biodiesel Blends.

~~2.31.1. Identification of Product. Biodiesel shall be identified by the term “Biodiesel” with the designation “B100.” Biodiesel Blends shall be identified by the term “Biodiesel Blend.”~~

~~2.31.2. Labeling of Retail Dispensers.~~

~~2.31.2.1. Labeling of Grade Required. Biodiesel and biodiesel blends shall be identified in accordance with both EPA and FTC requirements.~~

~~2.31.2.2. Automotive Fuel Rating. Biodiesel and biodiesel blends shall be labeled with its automotive fuel rating in accordance with 16 CFR 306.~~

~~2.31.2.3. Biodiesel Blends. When biodiesel blends greater than 20 % by volume are offered by sale, each side of the dispenser where fuel can be delivered shall have a label conspicuously placed that states “Consult Vehicle Manufacturer Fuel Recommendations.” The lettering of this legend shall not be less than 6 mm (1/4 in) in height by 0.8 mm (1/32 in) stroke; block style letters and the color shall be in definite contrast to the background color to which it is applied.~~

~~2.31.3. Documentation for Dispenser Labeling Purposes. The retailer shall be provided, at the time of delivery of the fuel, a declaration of the volume percent biodiesel on an invoice, bill of lading, shipping paper, or other document. This documentation is for dispenser labeling purposes only; it is the responsibility of any potential blender to determine the amount of biodiesel in the diesel fuel prior to blending.~~

~~2.31.4. Exemption. Biodiesel blends that contain less than or equal to 5 % biodiesel by volume are exempt from the requirements of Sections 2.31.1. Identification of Product, 2.31.2. Labeling of Retail Dispensers, and 2.31.3. Documentation for Dispenser Labeling Purposes when it is sold as diesel fuel. (Added 2008) (Amended 2022)~~

2.40. Diesel Fuel. – Shall meet the following requirements, based on the biodiesel concentration of the fuel:

- (a) Diesel fuel that contains less than or equal to 5 % by volume biodiesel shall meet the latest version of ASTM D975, “Standard Specifications for Diesel Fuels” and shall be sold as diesel fuel.
- (b) Diesel fuel that contains **biodiesel in concentrations** greater than or equal to 6 % by volume **biodiesel** and **that contains** less than or equal to 20 % by volume shall meet the latest version of ASTM D7467, “Standard Specifications for Diesel Fuel Oil, Biodiesel Blend (B6 to B20).”
- (c) **Diesel fuel that contains greater than or equal to 21 % by volume biodiesel shall be a blend of fuel from (a) or (b) and biodiesel meeting the latest version of ASTM D6751, “Standard Specification for Biodiesel Fuel Blend Stock (B100) for Middle Distillate Fuels.”**
- ~~(d) Only fuel additive registered with the U.S. EPA may be used to additize diesel fuel, and the final product shall meet the latest version of ASTM D975 and/or ASTM D7467.~~

(Amended 20XX)

2.40.1. Labeling of Retail Dispensers.

2.40.1.1. FTC Automotive Fuel Rating. – Diesel fuel shall be labeled with its automotive fuel rating in accordance with Automotive Fuel Ratings, Certification and Posting Rule 16 C.F.R. 306.

2.40.1.2. Biodiesel Concentrations 21% or Greater - When diesel fuel that contains biodiesel concentrations greater than or equal to 21 % by volume is offered by sale, each side of the dispenser where fuel can be delivered shall have a label conspicuously placed that states “Consult Vehicle Manufacturer Fuel Recommendations.” The lettering of this legend shall not be less than 6 mm (1/4 in) in height by 0.8 mm (1/32 in) stroke; block style letters and the color shall be in definite contrast to the background color to which it is applied.

2.40.1.3. Documentation for Dispenser Labeling Purposes. –The retailer shall be provided, at the time of delivery of the fuel, a declaration of the volume percent biodiesel and or volume percent of biomass-based diesel on an invoice, bill of lading, shipping paper, or other document. This documentation is for dispenser labeling purposes only; it is the responsibility of any potential blender to determine the amount of biodiesel in the diesel fuel prior to blending.

2.40.1.4. Delivery Documentation for Premium Diesel or Other Diesel Terminology Claims. – Before or at the time of delivery of the diesel fuel, the retailer or the wholesale purchaser-consumer shall be provided on an invoice, bill of lading, shipping paper, or other documentation a declaration of all performance properties that qualifies the fuel as premium diesel fuel as required in Section 2.40.2. Premium Diesel Fuel and 2.40.3. Use of Other Diesel Terminology.

(Added 20XX)

2.40.2. 2.40.1. Premium Diesel Fuel. – All diesel fuels identified on retail dispensers as premium, super, supreme, or premier must conform to the following minimum requirements.

2.40.3. 2.40.2. Use of Other Diesel Terminology – For any terms other than premium, super, supreme, or premier included in the diesel fuel product or grade name and/or advertisements and claims displayed on dispensers, pump toppers, pole signs, and bollard signs which imply improved performance, the product must have a clearly-defined fuel property with a substantiated functional benefit. Such property must be measurable utilizing industry-accepted test methodologies developed by recognized standards organizations such as ASTM, SAE, and CEC to allow verification of the improved performance.

(Added 2021) (Amended 20XX)

B1: FLR-23.1 A Sections 1.9. Biodiesel Blend., 1.27. Fuel Oil., 1.XX. Renewable Diesel., 3.3.2. Automotive Fuel Rating., 3.15. Biodiesel and Biodiesel Blends Containing Greater than 20% by Volume Biodiesel.

Item Under Consideration:

Amend the Uniform Fuels and Automotive Lubricants Regulation as follows:

Section 1. Definitions

1.9. Biodiesel Blend – A fuel comprised of **a homogeneous mixture of hydrocarbon oils and mono-alkyl esters of long-chain fatty acids.** ~~a blend of biodiesel with hydrocarbon diesel fuel.~~

(Amended 2018)

1.15. Diesel Fuel – ~~A refined hydrocarbon suitable for use as a fuel in a compression-ignition (diesel) internal combustion engine that may contain a combination of biodiesel, renewable diesel, and fuel additives.~~ **A liquid fuel specifically designed for injection into a compression-ignition engine to provide energy, commonly composed of hydrocarbons refined from petroleum or biomass and the fuel may contain biodiesel and fuel additives.**

(Amended 2018 **and 20XX**)

1.XX. Fuel Oil. – A liquid fuel designed for use in open flame applications to provide energy, commonly composed of hydrocarbons refined from petroleum or biomass and the fuel may contain biodiesel and fuel additives. The fuel may also be used in select compression-ignition engines.

Section 2. Standard Specifications

2.2. Diesel Fuel. – Shall meet the following requirements, based on the biodiesel concentration of the fuel:

- (a) Diesel fuel that contains less than or equal to 5 % by volume biodiesel shall meet the latest version of ASTM D975, “Standard Specifications for Diesel Fuels” and shall be sold as diesel fuel.
- (b) Diesel fuel that contains **biodiesel in concentrations** greater than or equal to 6 % by volume **biodiesel** and ~~that contains~~ less than or equal to 20 % by volume shall meet the latest version of ASTM D7467, “Standard Specifications for Diesel Fuel Oil, Biodiesel Blend (B6 to B20).”
- (c) **Diesel fuel that contains greater than or equal to 21 % by volume biodiesel shall be a blend of fuel from (a) or (b) and biodiesel meeting the latest version of ASTM D6751, “Standard Specification for Biodiesel Fuel Blend Stock (B100) for Middle Distillate Fuels.”**
- (d) Only fuel additives registered with the U.S. EPA may be used to additize diesel fuel, ~~and the final product shall meet the latest version of ASTM D975 and/or ASTM D7467.~~

(Amended 2003, ~~and~~ 2018, and 20XX)

Section 3. Classification and Labeling for Sale

3.3. Diesel Fuel.

3.3.1. Labeling of Retail Dispensers.

3.3.1.1. FTC Automotive Fuel Rating. – Diesel fuel shall be labeled with its automotive fuel rating in accordance with Automotive Fuel Ratings, Certification and Posting Rule 16 C.F.R. 306.

3.3.1.2. Biodiesel Concentrations 21% or Greater – When diesel fuel that contains biodiesel concentrations greater than or equal to 21 % by volume is offered by sale, each side of the dispenser where fuel can be delivered shall have a label conspicuously placed that states “Consult Vehicle Manufacturer Fuel Recommendations.” The lettering of this legend shall not be less than 6 mm (1/4 in) in height by 0.8 mm (1/32 in) stroke; block style letters and the color shall be in definite contrast to the background color to which it is applied.

3.3.1.3. Labeling of Grade Required. – Diesel Fuel other than No 2-D shall be identified by grade. (Added 20XX)

3.3.2. Documentation for Dispenser Labeling Purposes.

3.3.2.1. The retailer shall be provided, at the time of delivery of the fuel, a declaration of the volume percent biodiesel and or volume percent of biomass-based diesel on an invoice, bill of lading, shipping paper, or other document. This documentation is for dispenser labeling purposes only; it is the

responsibility of any potential blender to determine the amount of biodiesel in the diesel fuel prior to blending.

~~3.3.1. Labeling of Grade Required—Diesel Fuel other than No 2-D shall be identified by grade.
(Amended 2018)~~

~~3.3.2. Automotive Fuel Rating.—Diesel fuel containing 6 % to 20 % by volume biodiesel shall be labeled with its automotive fuel rating in accordance with the FTC “Automotive Fuel Ratings, Certification and Posting Rule,” 16 CFR 306.
(Added 2018) (Amended 20XX)~~

~~3.3.2.2. 3.3.3. Delivery Documentation for Premium Diesel or Other Diesel Terminology Claims. — Before or at the time of delivery of the premium diesel fuel, the retailer or the wholesale purchaser-consumer shall be provided on an invoice, bill of lading, shipping paper, or other documentation a declaration of all performance properties that qualifies the fuel as premium diesel fuel as required in Section 2.2.1. Premium Diesel Fuel and 2.2.2 Use of Other Diesel Terminology.
(Added 1998) (Amended 1999 and 20XX)
(Amended 1998, 1999, 2008, 2012, and 2018, and 20XX)~~

~~3.15. Biodiesel and Biodiesel Blends~~

~~3.15.1. Identification of Product.—Biodiesel Blendstock shall be identified by the term “biodiesel” with the designation “B100” or “B99.”
(Amended 2018)~~

~~3.15.2. Labeling of Retail Dispensers.~~

~~3.15.2.1. Labeling of Grade Required.—Biodiesel shall be identified by the grades No. 1-B S15 or No. 1-B S500, or No. 2-B S500.
(Amended 2018)~~

~~3.15.2.2. Automotive Fuel Rating.—Biodiesel and biodiesel blends shall be labeled with its automotive fuel rating in accordance with the FTC Automotive Fuel Ratings, Certification and Posting Rule, 16 CFR 306.
(Amended 2018)~~

~~3.15.2.3. Biodiesel Blends.—When biodiesel blends greater than 20 % by volume are offered by sale, each side of the dispenser where fuel can be delivered shall have a label conspicuously placed that states “Consult Vehicle Manufacturer Fuel Recommendations.”~~

~~The lettering of this legend shall not be less than 6 mm (¹/₄ in) in height by 0.8 mm (¹/₃₂ in) stroke; block style letters and the color shall be in definite contrast to the background color to which it is applied.~~

~~3.15.3. Documentation for Dispenser Labeling Purposes.—The retailer shall be provided, at the time of delivery of the fuel, a declaration of the volume percent biodiesel on an invoice, bill of lading, shipping paper, or other document. This documentation is for dispenser labeling purposes only; it is the responsibility of any potential blender to determine the amount of biodiesel in the diesel fuel prior to blending.~~

~~3.15.4. Exemption. Biodiesel blends that contain less than or equal to 5 % biodiesel by volume are exempted from the requirements of Sections 3.15.1. Identification of Product, 3.15.2. Labeling of Retail Dispensers, and 3.15.3. Documentation for Dispenser Labeling Purposes when it is sold as “diesel fuel” as required in Section 3.3. Diesel Fuel.~~

~~(Added 2005) (Amended 2008 and 2018)~~

NIST OWM Detailed Technical Analysis:

NIST OWM looks forward to reviewing the work of FALS.

Summary of Discussions and Actions:

At the 2023 NCWM Interim Meeting, the Committee designated an Assigned status to this block as it continues its development at the FALS.

At the 2023 NCWM Annual Meeting, Chuck Corr provided the latest developments that there were changes from the language that appeared in NCWM Publication 16. This modified language was the result of an IFG meeting. The IFG is on hiatus until after the fall Regional Association meetings. The IFG will reconvene and discuss any changes that may be needed and present this at the NCWM 2024 Interim Meeting. Additional information and background discussion can be found under Item OTH-07.1.

Regional Association Reporting:

Western Weights and Measures Association

At the 2022 WWMA Annual Meeting, Rebecca Richardson (Clean Fuels Alliance America), supported continued development of this item. Kevin Schnepf (California Department of Food and Agriculture, Division of Measurement Standards) proposed several changes:

- There are no current ASTM fuel quality standards for biodiesel, diesel blends greater than 20 %. This section would imply that there is.
- Deletion of 2.31.2.2. I do not see a need for this deletion.
- Deletion of 2.31.4. Exemption. I do not see a need for this deletion. This section clarifies that biodiesel, diesel blends less than 5 % as considered diesel fuel.
- Addition of 2.40.3 Labeling requirements: The FTC is covered in 2.31.2.2. If that section is deleted, then this requirement would be necessary.

B1: FLR-23.1

- 1.9. Biodiesel Blend. There are no current ASTM fuel quality standards for biodiesel, diesel blends greater than 20 %. This section would imply there is.
- 1.27. Fuel Oil. This is consistent with ASTM D396.
- 1.XX. Renewable Diesel. This is a weak definition that needs to be worked on.

NIST OWM Analysis
2024 NCWM Interim L&R Agenda Items

- 3.3.2. Automotive Fuel Rating. – This is consistent with 16CRF306.
- 3.15. Biodiesel and Biodiesel Blends containing greater than 20 % by volume biodiesel. This is attempting to establish biodiesel blends greater than 20 % by volume.
- 3.15.2.1. Labeling of Grade Required. This Fixes a miss B-2 S15 grade label.
- 3.15.2.2. Automotive Fuel Rating. This is the FTC requirement.
- 3.15.2.3. Biodiesel Blends. This section was not modified but I recommend that it be removed as there is no fuel quality standard for greater than 20 % biodiesel, diesel blends.
- 3.15.4. Exemption. – This is consistent with 16 CFR 306.

Based on testimony heard regarding this item not being fully developed, the WWMA L&R Committee recommends this item be assigned Developing status.

At the 2023 WWMA Annual Meeting, Randy Jennings (representing Clean Fuels Alliance America and FALS Vice Chair) supports this item moving forward, and has been working closely with Chuck Corr, (FG). Randy Jennings stated that the FALS gave no dissent to this item and posed no opposition to this item moving forward in July.

Chuck Corr submitted the following updates by email to the L&R Committee:

“These two items were assigned to FALS at the last Interim meeting. During the spring a focus group refined the proposal and presented it to all FALS members at the July national meeting. There was consensus to publish this version to get additional feedback from the fall regional meetings. The focus group will reconvene in November to consider the feedback received. We will then present it for full FALS review. We expect a final version at the January Interim Meeting and hope for a voting status.

During the development process the focus group received a number of comments that, where the FTC regulation is being implemented, we should use FTC terminology. The FTC regulations use the term biomass-based diesel. The intention was to replace renewable diesel with biomass-based diesel throughout the proposal. When preparing the final document, I made an error by not making the replacement in two locations. Please consider these two corrections:

- Page L&R 158 Line 12 replace the word “renewable” with “biomass-based”
- Page L&R 162 Line 32 replace the word “renewable” with “biomass-based””

Steven Harrington (Oregon) was in support of the proposal and encourages Voting status, as it is working to match language in 16 CFR part 306.

Kurt Floren (Los Angeles County, California) expressed that Randy Jennings is the premier expert on this topic. They also asked if there was a reason for the discrepancy between the 20 % and 21 % throughout the document. Randy Jennings replied that when measuring these quantities, the general rules of rounding would be applied.

Kevin Schnepf understood that discrepancies may be due to a rounding issue, however the gap between 20 % and 21 % may cause enforcement issues. Kevin Schnepf recommended this item remain assigned to FALS.

Joe Sorena (Chevron), Russ Lewis (Marathon Petroleum) and Bill Striejewske (Nevada) all stood in support of this item moving forward with the amendments as stated.

The WWMA recommends this item remain assigned to FALS until the final report is given by FALS in January, when this item may be escalated to Voting status.

Central Weights and Measures Association

At the 2022 CWMA Interim Meeting, Chuck Corr (Iowa RFA and submitter) reviewed the changes which they indicated are an extension to what was changed and approved at the 2022 NCWM Annual Meeting. Tamara Paik (Marathon) sees small differences between FTC rules, and this proposed item. They believe there should be more consistency between the two. Prentiss Searles (API) commented that there are some changes that can be made including consistent reference to CFR in section 3.3.2. (Citation references which Chuck Corr considers as editorial in nature). Mike Harrington (Iowa) supports the item and indicated Iowa has passed legislation to incentivize B30 so higher blends are coming to the marketplace. Scott Fenwick (Clean Fuels Alliance America) is supportive of the concept and supports consistent language and uniformity with citations throughout the Handbook. Mike Harrington also supports alignment and consistency across various sections of Handbook 130 as well as with FTC. The Committee believes that comments made regarding lack of consistency between FTC rules, EPA rules and what appears in the handbook are valid and should be further developed.

At the 2023 CWMA Annual Meeting, Chuck Corr commented that the item is assigned to FALS which has formed a focus group that will make a presentation in July at the FALS meeting.

At the 2023 CWMA Interim Meeting, Chuck Corr commented that this block was Assigned to FALS. The item has been updated, and the Focus Group will reconvene in November. Chuck Corr expects the final version by January 2024 and intends for the item to achieve Voting status. They further commented that this is found in Labeling of Retail Dispensers 2.40.1.3 L&R page 158, line 12, the word “renewable” should be replaced with “biomass-based”. Similarly, on Documentation for Dispenser Labeling Purposes 3.3.2.1 L&R page 162, line 32 the same correction should be made. This change is to keep the item consistent with FTC terminology.

The Committee recommends this item remain assigned to FALS.

Southern Weights and Measures Association

At the 2022 SWMA Annual Meeting, Randy Jennings (Clean Fuels) is generally in support of the items submitted and would like to see it go forward in some fashion. Speaking on their own behalf, they would like to suggest an amendment to the definition for diesel fuel to align with the recently updated ASTM D975.

Joe Sorena (Chevron) recommends the item remain in development and L&R consider alternate wording proposed concerning the concept of redefining the bio diesel blend containing greater than 20 %, as it is inconsistent with D7467 and will contribute to customer confusion.

NIST OWM Analysis
2024 NCWM Interim L&R Agenda Items

Matthew Curran (Florida) spoke with Chuck Corr regarding this item. Conceptually, approves this section. Inconsistencies were described found in the titles of MOS-23.1 and FLR-23.1 and a recommendation for clearer titles was made. They recommend in 2.31.2.1 verbiage is added to the specific EPA and FTC requirements.

Randy Jennings (Clean Fuels) suggested to form a focus group within FALS with Chuck Corr to lead and move this item forward.

The Committee corrected the title as follows:

Sections **2.231. Biodiesel and biodiesel Blends that Contain Greater Than or Equal to 21 % by Volume Biodiesel** and 2.40. Diesel Fuel.

The Committee agrees that this item needs more development and recommends this as a Developing Item on the NCWM Agenda.

At the 2023 SWMA Annual Meeting, the following update was provided by FALS Chair Benchea (Florida):

These two items were assigned to FALS at the last interim meeting. During the spring, a FG refined the proposal and presented it to all FALS members at the July national meeting. There was consensus to publish this version to get additional feedback from the fall regional meetings. This language can be found on page L & R 157 of the agenda.

The FG will reconvene in November to consider the feedback received. We will then present it for full FALS review. We expect a final version at the January NCWM Interim Meeting and hope for a voting status.

During the development process the FG received a number of comments that, where the FTC regulation is being implemented, we should use FTC terminology. The FTC regulations use the term biomass-based diesel. The intention was to replace renewable diesel with biomass-based diesel throughout the proposal. When preparing the final document, an error was made by not making the replacement in two locations. Please consider these two corrections:

- Page L&R 158 Line 12 replace the word “renewable” with “biomass-based”
- Page L&R 162 Line 32 replace the word “renewable” with “biomass-based”

Apologies for this error.

Again, we are looking for feedback on the proposal. You can either contact Chuck at **chuckcorrconsulting@gmail.com** or any FALS member.

Randy Jennings representing Clean Fuels and Russ Lewis, Marathon, both made comments in support of this item and the changes suggested.

The SWMA L&R Committee recommends this item remain assigned to FALS until the final report is given by FALS in January, when this item may be escalated to Voting status.

Northeastern Weights and Measures Association

At the 2022 NEWMA Interim Meeting, Rebecca Richardson (Clean Fuels Alliance America) commented supports the item moving forward with an Assigned status and recommends L&R refer it to FALS for further development. Jim Willis (New York) concurs. The Committee recommends Assigned status for this item.

At the 2023 NEWMA Annual Meeting, Rebecca Richardson offered an update on behalf of FALS stating that Chuck Corr who will have an update ready for the NCWM Annual Meeting in July. The Committee recommends this as an Assigned item.

At the 2023 NEWMA Interim Meeting, Jim Willis (New York) finds the wording confusing (21 % in the title vs. references to 20 % in the language) in the proposal, questioning transparency of renewable fuels with threshold of 20 % and 21 %. Walt Remmert (Pennsylvania) supports this as a ‘Voting’ item.

Item Block 2 (B2) Reference ASTM Standards D8080 and D8487

- B2: MOS-24.1 Section 2.9. Liquefied Natural Gas (LNG) Vehicle Fuel, 2.10. Compressed Natural Gas (CNG), and 2.XX. Compressed Natural Gas (CNG) Blended with Hydrogen
- B2: FLR-24.1 Section 3.11.2.1.X. Identification of Grade. and 3.12.2.X. Identification of Grade.

Source: AMT Consulting

Submitter’s Purpose and Justification:

Amend NIST HB 130, Uniform Regulation for the Method of Sale of Commodities: Sections 2.9 and 2.10 by replacing SAE J1616 and SAE J2699 with ASTM D8080 “Standard Specification for Compressed Natural Gas (CNG) and Liquefied Natural Gas (LNG) Used as a Motor Vehicle Fuel.”

Amend NIST HB 130, Uniform Regulation for the Method of Sale of Commodities, Section 2 by adding a new paragraph for ASTM D8487 “Standard Specification for Natural Gas, Hydrogen Blends for Use as a Motor Vehicle Fuel.”

Amend NIST HB 130, Uniform Fuels and Automotive Lubricants Regulation sections 3.10 and 3.11 by adding labeling of grades to the method of sale for CNG and LNG.

ASTM Committee D03 on Gaseous Fuels has adopted two new fuel quality specifications for natural gas vehicles:

ASTM D8080 “Standard Specification for Compressed Natural Gas (CNG) and Liquefied Natural Gas (LNG) Used as a Motor Vehicle Fuel”

ASTM D8487 “Standard Specification for Natural Gas, Hydrogen Blends for Use as a Motor Vehicle Fuel”.

These specifications are a replacement for both SAE J1616 (CNG) and SAE J2699 (LNG).

NIST OWM Analysis
2024 NCWM Interim L&R Agenda Items

ASTM D8080 is intended for natural gas vehicle fuels that have no additional hydrogen blend in the fuel. The specification establishes performance grades based on the fuel resistance to engine knock, energy content, and sulfur levels.

ASTM D8487 is intended for natural gas vehicle fuels that have additional hydrogen blended in the fuel. The specification covers natural gas fuels that have been blended with hydrogen and establishes performance grades based on the fuel resistance to engine knock, energy content, and sulfur levels. This specification is to be used in locations where hydrogen is being blended into the natural gas supply. This will become increasingly important as the natural gas supply has hydrogen blended to meet the decarbonization efforts of the U.S.

Both these standards are applicable at the point of dispensing into the vehicle fuel tank.

This proposal will require dispensers to be labeled with the product grade. This will require the product composition to be determined.

The submitter requested that the status be “Developing”.

| |
|---|
| NIST OWM Executive Summary for Item Block 2 (B2) –Reference ASTM Standards D8080 and D8487 |
| <p>NIST OWM Recommendation: NIST OWM believes this item has merit and looks forward to the development of this Item.</p> <ul style="list-style-type: none"> The submitter cites the incorrect Regulation within their submitted Form 15 and justification statement. The Item under Consideration for B2: MOS-24.1 and FLR-24.1 is amending the Uniform Regulation for the Fuels and Lubricants Regulation (NCWM identifier “FLR”) and not the cited Method of Sale Regulation (NCWM identifier “MOS”). |

**Table 2. Summary of Recommendations
Item Block 2 (B2) –Reference ASTM Standards D8080 and D8487**

| | Status Recommendation | Note* | Comments |
|-----------|-----------------------|-------|----------|
| Submitter | Developing | | |
| OWM | Developing | | |
| WWMA | Developing | | |
| NEWMA | Developing | | |
| SWMA | Developing | | |
| CWMA | Developing | | |
| NCWM | | | |

***Notes Key:**

- 1 Submitted modified language
- 2 Item not discussed
- 3 No meeting held
- 4 Not submitted on agenda
- 5 No recommendation or not considered

Item Under Consideration:

B2: MOS-24.1

Amend the Uniform Regulation for the Method of Sale of Commodities as follows:

2.9. Liquefied Natural Gas (LNG) Vehicle Fuel. – Shall meet the latest version of ~~SAE J2699, “Liquefied Natural Gas (LNG) Vehicle Fuel.”~~ **ASTM D8080 “Standard Specification for Compressed Natural Gas (CNG) and Liquefied Natural Gas (LNG) Used as a Motor Vehicle Fuel.”**

(Amended 20XX)

2.10. Compressed Natural Gas (CNG). – Shall meet the latest version of ~~SAE J1616, “Recommended Practice for Compressed Natural Gas Vehicle Fuel.”~~ **ASTM D8080 “Standard Specification for Compressed Natural Gas (CNG) and Liquefied Natural Gas (LNG) Used as a Motor Vehicle Fuel.”**

(Amended 20XX)

2.XX. Compressed Natural Gas (CNG) blended with hydrogen. **Shall meet the latest version of ASTM D8487 “Standard Specification for Natural Gas, Hydrogen Blends for Use as a Motor Vehicle Fuel.”**

(Amended 20XX)

B2: FLR-24.1

Amend the Uniform Fuels and Automotive Lubricants Regulation as follows:

3.11.2.1.X. Identification of Grade. – **Each retail dispenser of CNG shall be labeled with an identification of the grade of the product.**

3.12.2.X. Identification of Grade. – **Each retail dispenser of LNG shall be labeled with an identification of the grade of the product.**

NIST OWM Detailed Technical Analysis:

NIST OWM believes this item has merit and looks forward to its development. The submitter should review any regulations pertaining to LNG and CNG in FTC regulations or other requirements.

Additionally, the submitter cited the incorrect Regulation within their submitted Form 15. The Item under Consideration for B2: MOS-24.1 and FLR-24.1 are to amend the Uniform Regulation for the Fuels and Lubricants Regulation and not the cited Method of Sale Regulation

MOS 24.1 (should be relabeled by NCWM) NIST OWM agrees with the change in sections 2.9 and 2.10 by replacing SAE J1616 and SAE J2699 with ASTM D8080 “Standard Specification for Compressed Natural Gas (CNG) and Liquefied Natural Gas (LNG) Used as a Motor Vehicle Fuel. This change will bring in line the more widely used ASTM Standard within NIST Handbook 130.

With the inclusion of the ASTM Standard the submitter needs to align the labeling of the dispenser with the appropriate dispenser language differentiating the grades being sold.

Summary of Discussions and Actions

Regional Association Reporting:

Western Weights and Measures Association

At the 2023 WWMA Annual Meeting, Kevin Schnepf (California Department of Food and Agriculture, Division of Measurement Standards) stood in support of both items in Block 2. They stated that the ASTM standard that is specified in this item has been thoroughly vetted and is also a standard that accounts for hydrogen blending in natural gas, which is already adopted in Europe. Kevin Schnepf stated that these specifications meet the needs of industry and producers.

The WWMA recommends this item as Developing, as requested by the submitter.

Central Weights and Measures Association

At the 2023 CWMA Interim Meeting, no comments were heard. The Committee recommends this Item be Developing as requested by the submitter.

Southern Weights and Measures Association

At the 2023 SWMA Interim Meeting, the SWMA L&R Committee recommends this item as Developing as requested by the submitter. The Committee would also like to alert NCWM that some items listed in Block 2 are referenced incorrectly to the Method of Sale of Commodities Regulation and should reference the Fuels and Automotive Lubricants Regulation and are listed below:

MOS-24.1 to FLR-24.#

Amend NIST HB 130, ~~B. Uniform Regulation for the Method of Sale of Commodities~~ **F. Uniform Fuels and Automotive Lubricants Regulation**: sections 2.9 and 2.10 by replacing SAE J1616 and SAE J2699 with ASTM D8080 “Standard Specification for Compressed Natural Gas (CNG) and Liquefied Natural Gas (LNG) Used as a Motor Vehicle Fuel.”

Amend NIST HB 130 ~~B. Uniform Regulation for the Method of Sale of Commodities~~ **F. Uniform Fuels and Automotive Lubricants Regulation**, Section 2 by adding a new paragraph for ASTM D8487 “Standard Specification for Natural Gas, Hydrogen Blends for Use as a Motor Vehicle Fuel.”.

B2: FLR-24.1 3.11.2.1.X. Identification of Grade. and 3.12.2.X. Identification of Grade.

Item under Consideration:

Amend the ~~Uniform Regulation for the Method of Sale of Commodities~~ **Uniform Fuels and Automotive Lubricants Regulation** as follows:

3.11.2.1.X4. Identification of Grade. – Each retail dispenser of CNG shall be labeled with an identification of the grade of the product.

3.12.2.X4. Identification of Grade. – Each retail dispenser of LNG shall be labeled with an identification of the grade of the product.

Northeastern Weights and Measures Association

At the 2023 NEWMA Interim Meeting, no comments were heard. NEWMA supports this as a Developing item.

References:

- [1] NIST OWM Analysis and Executive reports <https://www.nist.gov/pml/owm/owm-technical-analysis>
- [2] National Conference on Weights and Measures Publication 15 (2024) and 16 (2023) <https://www.ncwm.com/>
- [3] 1905-2022 NCWM Annual Conference reports <https://www.nist.gov/pml/owm/national-conference-weights-measures-ncwm-related-reports>

Appendix A. Supporting Documents

There are no supporting documents.