

SCHUNK Dextrous Hand 2.0 (SDH 2.0)



Body Data

Overall Length	253 mm
Finger Length	155 mm
Finger Root Distance	66 mm
Factor to Human Hand	1.4 : 1
Total Weight	1.95 kg
Impermeability (aim)	IP 65

Kinematics

Number of Fingers	3
DOF (active) total	7
DOF (active) per Finger	2
DOF (active) 2-Finger-Pivot.	1

Motion Data

Angular Joint Speed max.	210°/sec
Moment (Proximal Joint)	2.1 Nm
Moment (Distal Joint)	1.4 Nm
Accuracy	0.011°

Electronics

Voltage	24 V
Currency (grasping object)	5 A
Communication:	CAN / Ethernet / RS232

Sensors

Absolute Encoder	7
Tactile Sensor Arrays	6

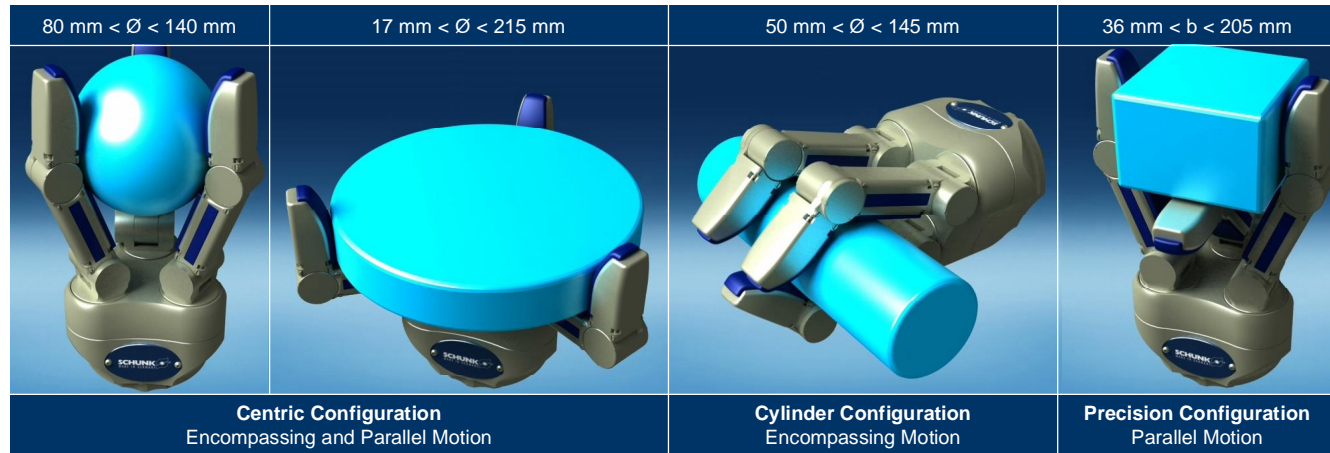
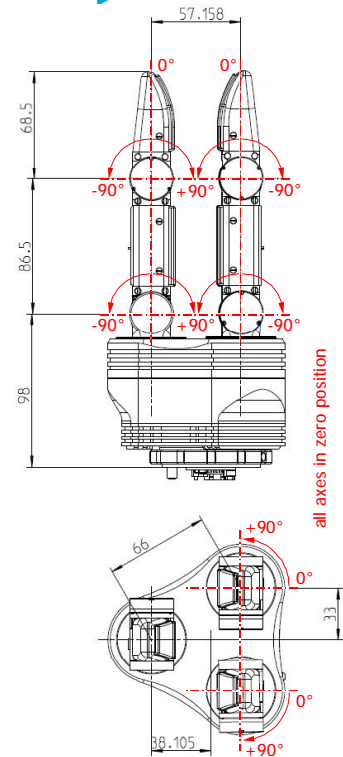
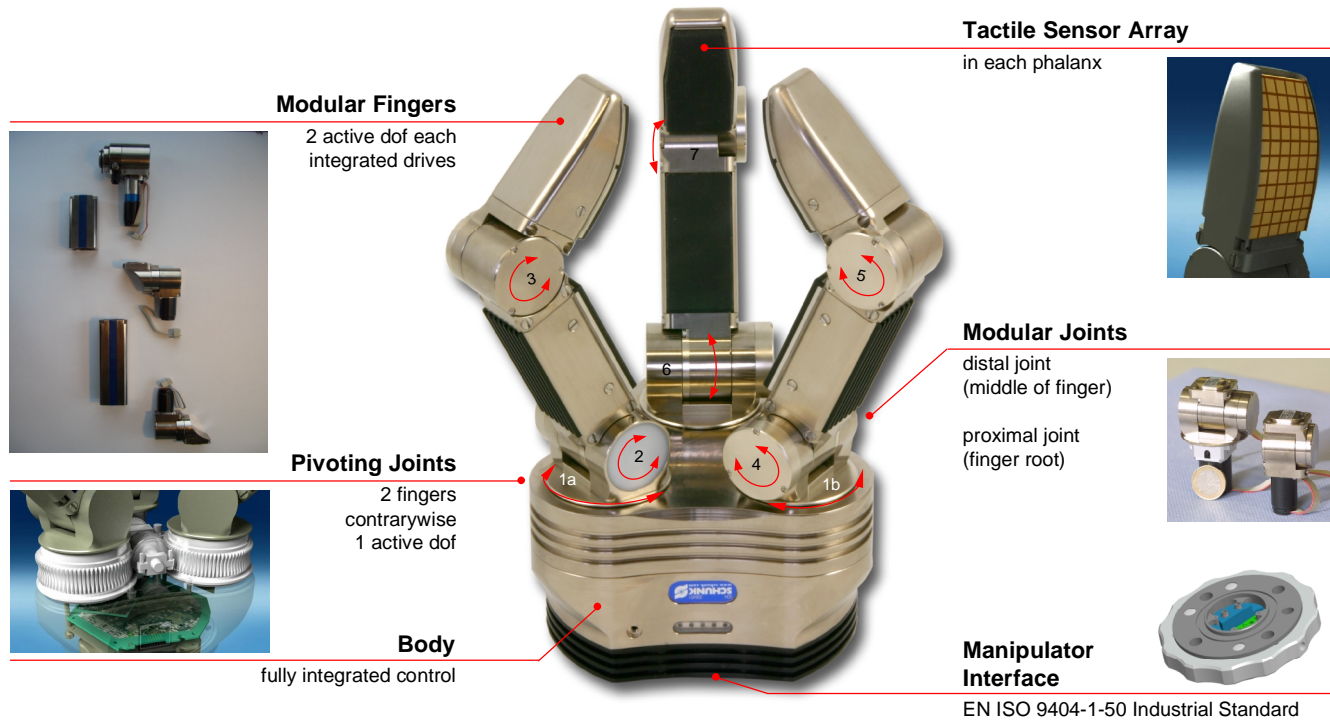

SCHUNK GmbH & Co. KG

Bahnhofstrasse 106-134
74348 Lauffen / Neckar
Germany

+49 (7133) 103-0
info@de.schunk.com
http://www.schunk.com