

Schedule for Monday, 12 JUN 2017

| Start | End | Session | Speaker | Title |
|-------|-------|------------------------------|-----------------------|---|
| 8:30 | 9:00 | Arrive | | |
| 9:00 | 9:20 | <i>Welcome</i> | PML Director's office | PML / NIST Overview |
| 9:20 | 9:40 | | Jeff Nico | Neutron Physics Overview |
| 9:40 | 10:00 | | Daniel Hussey | Neutron Imaging Overview |
| 10:00 | 10:30 | Coffee | | |
| 10:30 | 11:00 | <i>Facilities</i> | Michael Lerche | The ODIN Project at the European Spallation Source |
| 11:00 | 11:30 | | Takenao Shinohara | Present status of the Energy-Resolved Neutron Imaging System, RADEN, in J-PARC |
| 11:30 | 12:00 | | Triestino Minniti | Characterisation of the TOF imaging instrument IMAT |
| 12:00 | 12:30 | | Yoshiaki Kiyonagi | Present status of accelerator driven neutron facilities with capability of imaging in Japan |
| 12:30 | 13:30 | Lunch, NIST Cafeteria | | |
| 13:30 | 14:00 | <i>Phase Imaging</i> | Markus Strobl | Perspectives of quantitative neutron time-of-flight dark-field imaging |
| 14:00 | 14:30 | | Dimtri Pushin | Neutron Twisted Waves and their Spin-Orbit Coupling |
| 14:30 | 15:00 | | Ralph Harti | Sub-pixel correlation length imaging of the heterogeneous formation of a colloidal crystal |
| 15:00 | 15:30 | | Les Butler | Neutron Interferometry of Stressed Additive Manufacturing Samples |
| 15:30 | 16:00 | Coffee | | |
| 16:00 | 16:30 | <i>Bragg Edge Analysis</i> | Søren Schmidt | 3D Neutron Diffraction (3DND) methodology – second generation algorithms |
| 16:30 | 17:00 | | Jean Bilheux | Imaging Bragg Edge Analysis Tool for Engineering Structure – iBeatles |
| 17:00 | 17:30 | | Marc Raventos | Forward model algorithm for multigrain indexing in Laue mode |
| 17:30 | 18:00 | Transit to Hotel | | |
| 18:00 | 20:00 | Dinner, on own | | |
| 20:00 | 23:00 | Poster Session | | |

The ODIN Project at the European Spallation Source

M. Lerche¹, M. Morgano², M. Strobl² and E. Calzada¹

¹Technische Universität München, FRM2, Germany

²Paul Scherrer Institut, SinQ, Switzerland

ODIN (Optical and Diffraction Imaging with Neutrons) is a beamline project at the European Spallation Source (ESS). It is a collaboration between the ESS, PSI and TUM, with TUM as lead institution. ODIN will provide a multi-purpose imaging capability with spatial resolutions down to the μm -range. The pulsed nature of the ESS source will give access to wavelength-resolved information. Different imaging techniques, from traditional attenuation-based imaging to advanced dark field, polarized neutron or Bragg edge imaging, will be available within the full scope of ODIN with unprecedented efficiency and resolution. A summary of the technical full scope and its science application will be given and the updated conceptual instrument design including its challenges, see Figure 1, will be presented.

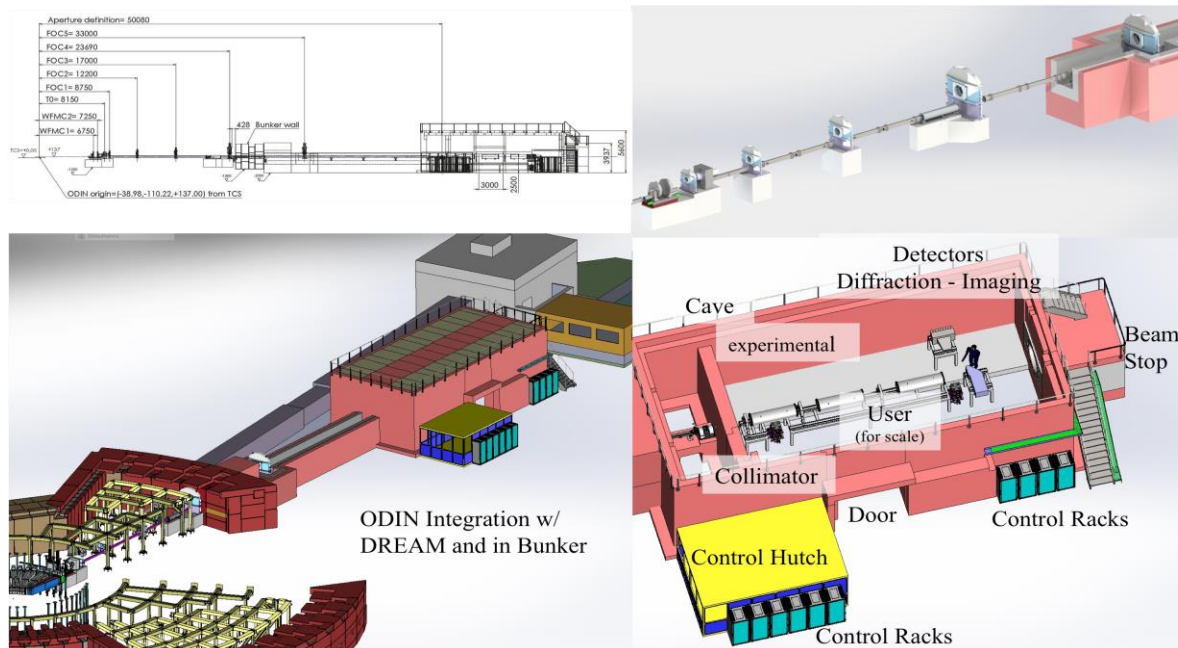

Figure 1: ODIN Design and layout

Present status of the Energy-Resolved Neutron Imaging System, RADEN, in J-PARC

T. Shinohara¹, T. Kai¹, K. Oikawa¹, K. Hiroi¹, Y. Su¹, M. Segawa¹, T. Nakatani¹, H. Hayashida²,
Y. Matsumoto², J. D. Parker², W. Ueno¹, Y. Seki¹, Y. Kiyanagi³

¹*J-PARC Center, Japan Atomic Energy Agency, Tokai, Ibaraki, Japan*

²*Neutron R&D Division, CROSS-Tokai, Tokai, Ibaraki, Japan*

³*Graduate School of Engineering, Nagoya University, Nagoya, Aichi, Japan*

The Energy-Resolved Neutron Imaging System, RADEN, in the Materials and Life Science Experimental Facility (MLF) of J-PARC [1] has been open for general users from JFY 2015, and we have accepted 47 proposals through the 2017A period. Besides the user program, the RADEN instrument group is continuing the development on both energy-resolved neutron imaging, i.e. Bragg edge, resonance absorption, and polarized pulsed neutron imaging, and conventional neutron imaging techniques so as to fully utilize the short-pulsed neutron beam of the MLF. Especially, improvement of the 3D polarization analysis apparatus has been done so as to achieve precise neutron spin control in three dimensions and to decrease the sample-to-detector distance. Additionally, the validity of Bragg-edge imaging was confirmed by comparing evaluated quantities from the profile fitting of Bragg edge spectra using RITS code [2] and those obtained by other techniques, and application studies of Bragg-edge imaging technique to practical steel objects have been performed.

In this presentation, we will report the present status of RADEN along with recent results of both the technical development and application studies regarding energy-resolved neutron imaging techniques conducted at RADEN.

References

[1] T. Shinohara et al., J. Physics: Conf. Series 746, 012007 (2016).

[2] H. Sato et al., Mater. Trans. 52, 1294 (2011).

Characterization of the TOF imaging instrument IMAT

Triestino Minniti¹, Kenichi Watanabe², Genoveva Burca¹, Daniel Pooley¹, Winfried Kockelmann¹

¹STFC, Rutherford Appleton Laboratory, ISIS Facility, Harwell, OX11 0QX, United Kingdom

²Nagoya University, Furo-cho, Chikusa-ku, Nagoya, 464-8603, Japan

IMAT is a new cold-neutron imaging facility, recently installed on the target station 2 (TS2) at the ISIS neutron spallation source. The pulsed source enables energy-selective and energy-dispersive imaging options via time-of-flight (TOF) techniques, which are available in addition to the white-beam neutron radiography and tomography operation. During the first six month of commissioning of IMAT basic instrument parameters for radiography and tomography have been determined, including the neutron beam flux profiles, absolute neutron flux values, guide artifacts, neutron beam inhomogeneity, divergence and spatial resolution and neutron pulse widths. Data from these commissioning tests will be presented. Furthermore, we will report a preliminary study on dissimilar electron beam welds as an example of energy-dispersive neutron imaging.

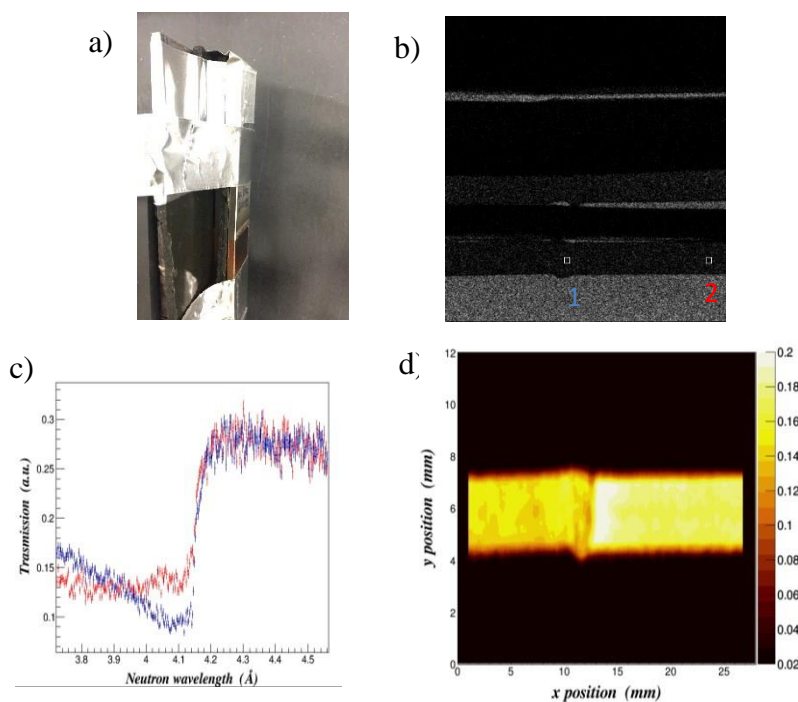

Figure: a) photo of the sample mounted on the IMAT beamline; b) neutron transmission image, measurement points indicated; c) comparison of the Bragg Edge shape (110) for Fe and (111) for Cu from the highlighted pixels; d) Bragg Edge intensity map obtained by pixel by pixel analysis.

Present status of accelerator driven neutron facilities with capability of imaging in Japan

Y. Kiyanagi

Graduate School of Engineering, Nagoya University

Neutron imaging has become very popular and recognized to be useful for scientific and engineering applications. This trend is also true in Japan. As well-known one of biggest facilities is J-PARC/MLF and the RADEN instrument was installed. Furthermore, accelerator driven neutron compact neutron sources are working and new facilities are being constructed. Hokkaido University Neutron Source (HUNS) is being used for Bragg edge imaging, resonance imaging, white beam imaging, RIKEN neutron source (RANS) for white beam imaging and energy selective imaging, KURRI-LINAC for resonance imaging, Kyoto University neutron source (KUANS) also for energy selective and white beam imaging, etc. Furthermore, commercial neutron source SHIEI have been working as a neutron source for imaging. Recently, some of BNCT neutron sources are planned to be used for imaging. For example, Ibaraki BNCT and Nagoya BNCT facilities. A neutron source is now under construction in Aomori prefecture, which aims at multi-purpose use of a proton accelerator including the imaging. One more neutron source for neutron scattering and imaging will be constructed in Ibaraki prefecture.

Thus, compact neutron source activity in Japan is very high and the present status will be presented at the meeting.

Perspectives of quantitative neutron time-of-flight dark-field imaging

M. Strobl^{1,2,3}, R. P. Harti¹, J. Plomp⁴, A. Kusmin⁴, C. Grünzweig¹, R. Woracek²

¹Laboratory for Neutron Scattering and Imaging, Paul Scherrer Institut, Switzerland

²European Spallation Source E.R.I.C., Sweden

³Niels Bohr Institute, Copenhagen University, Denmark

⁴Reactor Institute Delft, Technical University Delft, Netherlands

During the last decades, neutron scattering and imaging have not only achieved an overlap in accessible structure sizes, but also have been merged in several techniques taking advantage of diffraction and scattering while probing macroscopic variations with real space image resolution [1]. These methods naturally require both imaging detection and wavelength resolution and hence the best available neutron phase space densities. Particularly promising recent approaches are developed in neutron imaging with respect to either probing small angle scattering (SAS) through dark-field contrast imaging [2] (DFI) and diffraction through spatially resolved Bragg edge signatures of crystalline materials in the transmitted beam.

Dark field contrast in neutron imaging refers to contrast that is achieved by the ability to detect scattering to small angles through losing contrast of a beam focused in angle [3] or space [2,4-6] to its background around the initial focus of intensities. In grating interferometric imaging with x-rays as well as with neutrons the beam is spatially modulated on the detector through a Talbot Lau absorption and phase grating set-up. The loss of beam modulation induced by a sample in the beam is a measure of small angle scattering of the sample within a certain scattering vector range. Variations in the probed scattering vector range, or better autocorrelation length probed, through geometry scans or wavelength dispersive measurements enable quantitative spatially resolved SAS studies [7]. Subsequently an alternative method to modulate a polarized neutron beam through spin manipulations has been introduced as spin-echo modulation dark field imaging [4].

On the other hand, it has also been shown that energy dispersive attenuation measurements, which are straightforward at pulsed neutron sources, enable access to a wealth of additional information in imaging. This is in particular the case for crystalline materials where the elastic coherent Bragg scattering dominates the attenuation of the beam in the range of cold neutrons. Correspondingly the transmitted wavelength resolved spectrum provides insights with respect to the crystalline structures in the sample.

Hence, energy resolved neutron imaging in time-of-flight (ToF) utilizing a grating interferometer does, besides the conventional image resolution in real space, not only enable access to the micrometer size range through DFI but also to the nanometer size range of crystalline structures and phenomena through the measured energy resolved attenuation. Hence multiple length scales from nanometers to centimeters become accessible simultaneously, opening new potentials for a new range of studies and in-situ applications. Such studies will profit significantly from pulsed sources and the ESS will provide an unprecedented potential to advance such techniques [8].

References

1. Strobl M. & Grazzi F., *Neutron News* **26**:2 (2015)
2. Strobl M., et al., *Phys. Rev. Lett.* **101**, 123902 (2008)
3. Strobl M., Treimer W., Hilger A., *Appl. Phys. Lett.*, **85**, 3, (2004)
4. Strobl M. et al., *Scientific reports* **5**, 16576 (2015).
5. Strobl M., et al., *J. of Appl. Cryst.* **49** (2016).
6. Harti R. P., et al., *Scientific Reports* **7**, (2017)
7. Strobl M., *Scientific Reports* **4** (2014)
8. Strobl M., *Physics Procedia* **69** (2015)

Neutron Twisted Waves and their Spin-Orbit Coupling

D. Sarenac,^{1,2} M. Arif,³ W.C. Chen,^{3,4} C.W. Clark,^{5,3} D.G. Cory,^{2,1,6,7} B. Heacock,^{8,9} I. Hincks,^{2,1} M.G. Huber,³ J. Nsofini,^{10,2} C. B. Shahi,⁵ and D. A. Pushin^{10,2}

¹University of Waterloo, Waterloo, ON, Canada, N2L3G1; ²Institute for Quantum Computing, University of Waterloo, Waterloo, ON, Canada, N2L3G1; ³National Institute of Standards and Technology, Gaithersburg, MD 20899, USA; ⁴University of Maryland, College Park, MD 20742, USA; ⁵Joint Quantum Institute, University of Maryland, College Park, MD 20742, USA; ⁶Perimeter Institute for Theoretical Physics, Waterloo, ON, Canada, N2L2Y5; ⁷Canadian Institute for Advanced Research, Toronto, Ontario, Canada, M5G 1Z8; ⁸North Carolina State University, Raleigh, NC 27695, USA; ⁹Triangle Universities Nuclear Laboratory, Durham, NC 27708, USA ¹⁰Department of Physics, University of Waterloo, Waterloo, ON, Canada, N2L3G1

Most waves encountered in nature can be given a “twist”, so that their phase winds around an axis parallel to the direction of wave propagation. Such waves are said to possess orbital angular momentum (OAM). For quantum particles such as photons, atoms, and electrons, this corresponds to the particle wavefunction having angular momentum of L_H along its propagation axis, where the integer L is called the winding number or topological charge.

Orbital angular momentum control of neutrons was demonstrated in 2015 [1]. Neutron interferometry with a spatially incoherent input beam, it has been used to show the addition and conservation of OAM (Fig. 1a) and entanglement between quantum path and OAM degrees of freedom. A spiral phase plate used in these experiments has been holographically imaged using a neutron interferometer [2]. The resulting hologram is a fork dislocation image, consistent with the predictions of [4].

Neutrons have an intrinsic spin, and here we suggest a means of coupling neutron spin and OAM to obtain an entangled spin-orbit state [3]. A Ramsey-fringe-type measurement is suggested as a means of verifying the spin-orbit correlations (Fig. 1b).

Neutron-based quantum information science, heretofore limited to spin, path, and energy degrees of freedom, now has access to another quantized variable, and OAM modalities of light, x-ray, and electron beams are extended to a massive, penetrating neutral particle. The methods of neutron phase imprinting demonstrated here expand the toolbox available for development of phase-sensitive techniques of neutron imaging.

References

- [1] Clark C. W., et al., Controlling neutron orbital angular momentum, *Nature* 525, pp. 504-506, 2015.
- [2] Sarenac D., et al., Holography with a neutron interferometer, *Optics Express* 24, pp. 22528-22535, 2016.
- [3] Nsofini J., et al., Spin orbit states of neutron wavepackets, *Phys. Rev. A* 94, p. 013605, 2016.
- [4] Bazhenov, V. I., et al., Laser beams with wave front screw dislocations, *Pisma v ZETF* 52, 1037-1039, 1990.

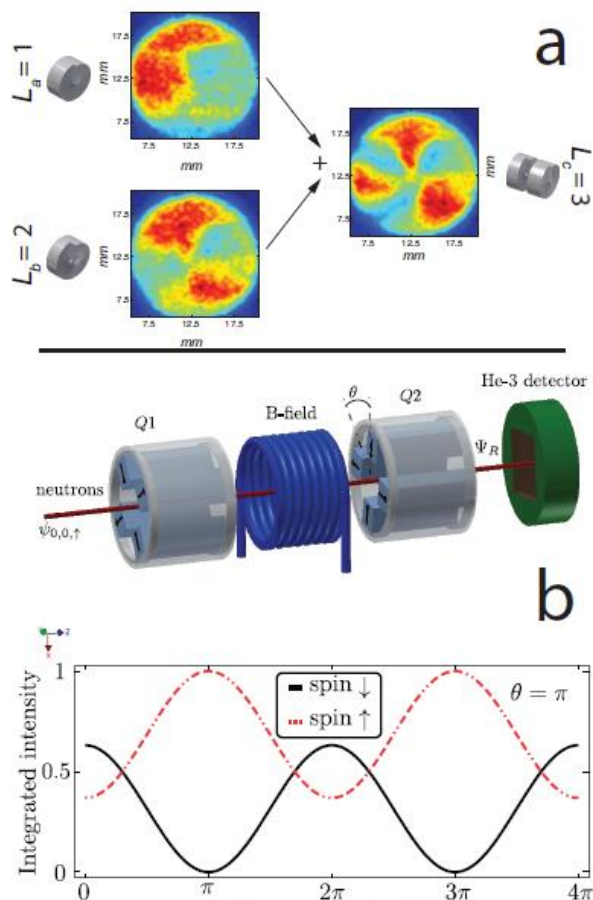

Figure 1. a) Addition of angular momenta along the direction of propagation accomplished by two spiral phase plates. Interferograms represent neutron phase profile after passage through the plates [1]; b) Above: schematic of a spin-orbit Ramsey fringe

Sub-pixel correlation length imaging of the heterogeneous formation of a colloidal crystal

R. P. Harti¹, M. Strobl^{2,3}, C. Grünzweig¹

¹ Paul Scherrer Institut, Laboratory for Neutron Scattering and Imaging, 5232 Villigen PSI, Switzerland

² European Spallation Source E.R.I.C., Lund 22100, Sweden

³ University of Copenhagen, The Niels Bohr Institute, Copenhagen 2100, Denmark

The dark-field image in neutron grating interferometry makes it possible to assign an experimentally variable and wavelength dependent autocorrelation length (500 nm to 4.5 μm) to the recorded images¹. With that the autocorrelation function of the scattering system can be extracted in each pixel. We will present the first experimental work that utilizes the spatial resolution of scattering functions by studying the heterogeneous formation of colloidal crystals made from micrometer sized particles². A slight mismatch between particle and solution density leads to gravity induced sedimentation at a rate that allows the formation of crystalline order. The combined imaging and scattering information enables us to study the transition regions from unordered phases to the ordered crystalline structure in a previously inaccessible macroscopic volume. Therefore, our work can also serve as a guideline for future studies that combine neutron imaging and scattering in a single neutron grating interferometry experiment in order to probe macroscopic length scales as well as micrometer and sub-micrometer structures simultaneously. Furthermore, we show how neutron scattering principles find their way into imaging in terms of data analysis and interpretation.

References

1. General solution for quantitative dark-field contrast imaging with grating interferometers, M. Strobl, Scientific Reports 4, 7243 (2014)
2. Sub-pixel correlation length neutron imaging: Spatially resolved scattering information of microstructures on a macroscopic scale, R. P. Harti et al., Scientific Reports 7, 44588 (2017)

Neutron Interferometry of Stressed Additive Manufacturing Samples

Adam Brooks¹, Nikolay Kardjilov², Daniel S. Hussey³, Shengmin Guo⁴, Michael M. Khonsari⁴, and Leslie G. Butler¹

¹Dept. of Chemistry, Louisiana State University, Baton Rouge, LA USA

²Helmholtz-Zentrum Berlin für Materialien und Energie GmbH, Berlin D-14109, Germany

³National Institute of Standards and Technology, 100 Bureau Dr., Mail Stop 8461, Gaithersburg, MD

⁴Department of Mechanical and Industrial Engineering, Louisiana State University, Baton Rouge, LA

Stress and fatigue in selective laser melted SS316 dogbones were studied with neutron interferometry (2D and 3D) and Bragg edge imaging. The hypotheses for stress and fatigue failure include modifications to both grain structure and microcracks. Two methods of grating-based neutron interferometry were used: A Talbot-Lau interferometer yielded good spatial resolution, but operated at fixed auto-correlation scattering length of 2 μm . A far-field interferometer was used to acquire images reflecting scattering lengths 0.6 to 2 μm , though the images suffered from geometric blur at the longer scattering lengths. Bragg edge imaging showed a change in crystallographic structure and/or texture at pre-existing fractures, but did not provide evidence for presumptive crack formation. Preliminary crack formation may have been observed with both 2D far-field and 3D Talbot-Lau interferometry.

Figure 1. The stressed sample (#630) was imaged with stress axis perpendicular to the scattering plane (Expt.#2) and parallel (Expts. #6, #8) The volume rendering (#2) showed two regions of interest (crosses) while the line probes showed partial agreement. Line probe with an interior-only mask showed nearly superimposable traces but with less clearly defined observation of the presumptive cracks.

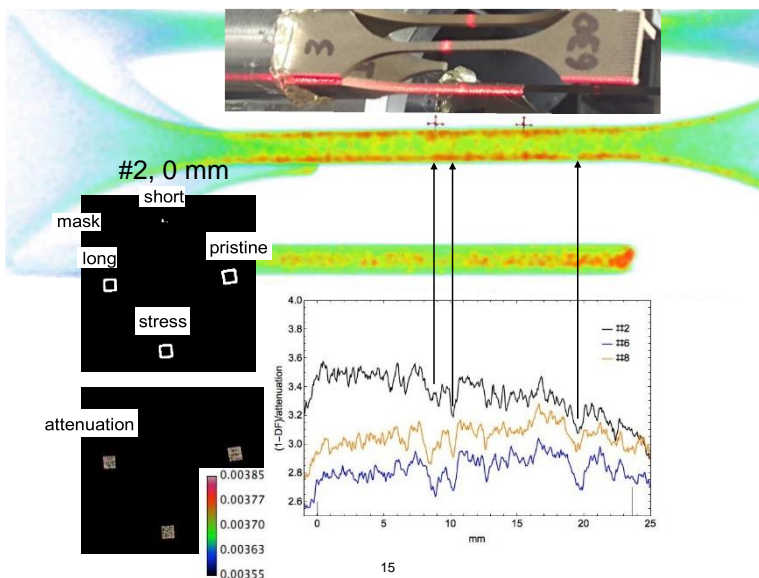

3D Neutron Diffraction (3DND) methodology – second generation algorithms

Søren Schmidt

Department of Physics, Technical University of Denmark, email: ssch@fysik.dtu.dk

At NEUWAVE-8 the 3D Neutron Diffraction (3DND) methodology for non-destructive characterization of crystalline structures in polycrystalline materials was presented along with a feasibility study, see also [1]. The data analysis was carried out on a grain by grain basis. Meanwhile, the 3DND algorithm development has continued towards establishing a new software platform for 3DND reconstructions with local characterization of crystalline properties, such as phase and orientation. Consequently, the methodology doesn't operate with the concept of grains but rather on a series direct space sub-volumes, within which the local crystalline properties are determined. The underlying principle of analyzing each sub-volume independently has previously been introduced with success for x-ray diffraction [2]. Here, this concept has been adopted to time-of-flight neutrons for simultaneous utilization of transmission (extinction) and diffraction data. This novel approach uses an optimized distribution of seed orientation volumes [3] enabling a fast search scheme to identify the local orientations. The end goal is to facilitate robust and fast reconstruction of complex structural configurations, such as multi-phased microstructures and/or microstructures with mosaicity. Here, the current state of the second generation 3DND algorithms are presented.

References:

- [1] A. Cereser et al, submitted. Also available on: [arXiv:1704.06589](https://arxiv.org/abs/1704.06589)
- [2] S. Schmidt et al., Scripta Mater. (2008), 59, 491-494.
- [3] P. M. Larsen and S. Schmidt, submitted.

Imaging Bragg Edge Analysis Tool for Engineering Structure – iBeatles

Jean Bilheux, Gian Song, Hassina Bilheux, Jiao Lin

Oak Ridge National Laboratory

The Spallation Neutron Source (SNS) at Oak Ridge National Laboratory (ORNL) provides pulsed neutrons with energies varying from epithermal to cold. In preparation for VENUS, the neutron imaging beamline to be located at beam port 10, we have performed a series of experiments focused on wavelength- dependent radiography and computed tomography for a broad range of applications, from materials science to biological tissues.

One of the time-of-flight (TOF) techniques that is of interest to the scientific community is the 2-dimensional mapping of phases and average crystalline plane orientation in samples both ex-situ and during applied stresses such as tensile loading and heating. This technique is known as Bragg edge imaging and relies on the identification of changes of transmission values, fitting of the edge to measure its displacement, and thus identify the shift in lattice parameter due to stresses. One of the challenges of TOF imaging measurements is the amount of data and the inability to observe Bragg edge shifts in real time during an experiment. Thus, we have been focusing on creating a Python-based interface that allows fast data processing and instantaneous mapping and fitting of the Bragg edges, and their evolution through time.

Python libraries and Jupyter notebooks have been implemented to facilitate decision making during an experiment. The advantage of the notebooks is the possibility to guide an experiment as they can quickly process and display Bragg edge data. These notebooks can be used independently, or can be combined in a Python Graphical User Interface (GUI) tool called iBeatles. This interface permits visualization and fitting of the Bragg edges, and ultimately back-projects the fitting results onto the radiographs to display a strain map. Assuming data collection has sufficient statistics, the strain mapping analysis can be performed on a pixel-by-pixel basis. This development is a step forward toward a better user experience at the future VENUS beamline in terms of live feedback and productivity. Analysis that used to take days of switching between different applications can now be done in minutes within the same interface.

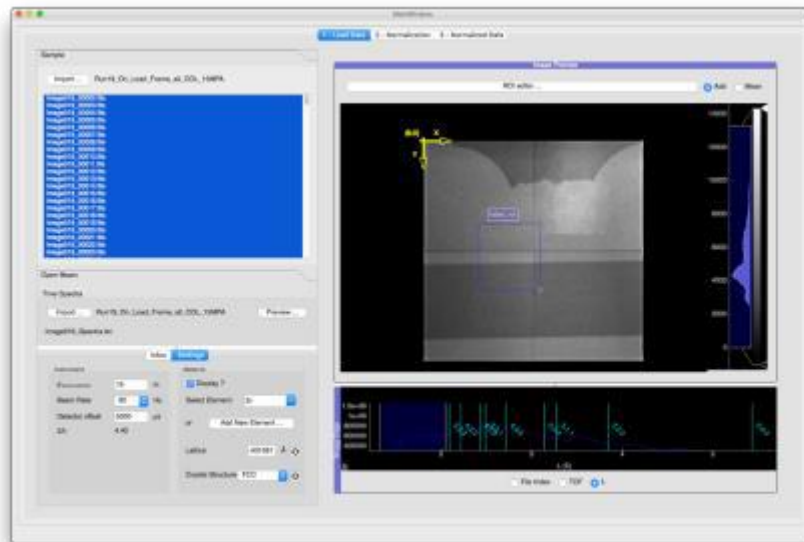

Forward model algorithm for multigrain indexing in Laue mode

M. Raventos,^{1,2} E. Lehmann,¹ C. Grünzweig¹, M. Tovar³ and S. Schmidt⁴

¹ NIAG, Paul Scherrer Institut, CH-5232 Villigen PSI, Switzerland;

² DQMP, University of Geneva, CH-1211 Geneva, Switzerland

³ Helmholtz-Zentrum, 14109 Berlin, Germany

⁴ Department of Physics, Technical University of Denmark 2800 Kgs. Lyngby, Denmark

Polycrystalline materials undergoing thermal or mechanical loading suffer deformations and damage which can modify their grain size, orientation and texture. To study these effects, multigrain indexing permits the study of their crystalline structure through diffraction techniques. The indexing and 3D reconstruction of multiple grains has been previously demonstrated for neutrons [1].

We propose a new method for grain indexing. By comparing experimental Laue diffraction data with a forward model, we can obtain the orientation and position of every grain in a polycrystalline sample. The model requires information about the crystal structure of the material and the beamline setup, such as spectrum, detector geometry and sample-to-detector distance. The experimental data is composed of diffractive images with different rotation angles measured in Laue mode with neutron imaging detectors. The diffraction spots are then identified with the FABLE [2] package and feed into the forward model solver.

The solver first places a trial grain in the center of the beam and tries 25^3 possible orientations, stepping through the whole orientation space of the given crystal. For every orientation, the distance between the predicted spot and the closest experimental spot is calculated. Then, the average distance between experimental and predicted spots is computed for every orientation, and the orientations with the smallest average distances are tagged as candidates. Candidate orientations are then fed into a constrained optimization function, which adjusts the rotation axis deviation from the center of the beam, the position of the grain with respect to the rotation axis and the precise orientation of the grain. When all candidates have been fitted, the one with the lowest objective value as solution is saved, and the fitted experimental spots are removed from the initial group of spots. The constrained optimization function is rerun without the fitted spots to find the next grain.

We have currently indexed 5 grains from a dataset (40 steps, 240° rotation) of a Fe sample measured at the FALCON beamline of HZB. The strength of this method lies in the use of the full white beam spectrum of a continuous source to perform multi-grain indexing with a faster data acquisition than before. This method shows promising results for applications on quality assessment of crystal growth methods and study of annealed samples for metallurgy.

References:

- [1] Peetermans, S., King, A., Ludwig, W., Reischig, P., & Lehmann, E. H. (2014). *Analyst*. 139, 5765-5771.
- [2] http://www.chess.cornell.edu/software/anaconda/GrainMapping_instructions.pdf

Schedule for Tuesday, 13 JUN 2017

| Start | End | Session | Speaker | Title |
|-------|-------|------------------------------|----------------------|--|
| 8:30 | 9:00 | Arrive | | |
| 9:00 | 9:30 | <i>Instrumentation</i> | Matthew Connolly | In Situ Neutron Transmission Bragg Edge Measurement of Strain Fields Near Fatigue Cracks Grown in Hydrogen |
| 9:30 | 10:00 | | Yoshiyuki Takahashi | Improvement of a Neutron Source and a Beam Line for Pulsed Neutron Imaging at KURRI-LINAC |
| 10:00 | 10:30 | | Robin Woracek | Developing key capabilities for neutron imaging at ESS Using the ESS Testbeamline at HZB |
| 10:30 | 11:00 | Coffee | | |
| 11:00 | 11:30 | <i>Magnetic Imaging</i> | Boris Khaykovich | Towards polarized neutron microscope for studies of magnetic domains and magnetic phase transitions |
| 11:30 | 12:00 | | Morten Sales | Three Dimensional Polarimetric Neutron Tomography of Magnetic Fields |
| 12:00 | 12:30 | | Wolfgang Triemer | Study of shape dependent flux trapping with polarized neutrons |
| 12:30 | 13:30 | Lunch, NIST Cafeteria | | |
| 13:30 | 14:00 | <i>Instrumentation</i> | Burkhard Schillinger | Optimizing the design and use of neutron imaging facilities |
| 14:00 | 14:30 | | Joseph Parker | Present status of neutron imaging detector development at RADEN |
| 14:30 | 15:00 | | Nikolay Kardjilov | Double-crystal monochromator device for energy-selective imaging |
| 15:00 | 15:30 | | Indu Dhiman | Development of polarized neutron imaging technique on CG-1D beamline for the investigation of superconductors and magnetic transitions |
| 15:30 | 16:00 | Coffee | | |
| 16:00 | 16:30 | <i>Phase Imaging</i> | Luisa Riik | Complementary information: Ultra small angle scattering and radiography with polarized neutrons on magnet steel samples |
| 16:30 | 17:00 | | Jacopo Valsecchi | Quantitative visualization of the magnetic induced phase shift with polarized neutron grating interferometry |
| 17:00 | 17:30 | | Michael Huber | Three Phase-Grating Moiré Neutron Interferometer |
| 17:30 | 18:00 | Transit to Hotel | | |
| 19:00 | 21:00 | Workshop Dinner | | |

In Situ Neutron Transmission Bragg Edge Measurement of Strain Fields Near Fatigue Cracks Grown in Hydrogen

Connolly M.J.¹, Hussey, D.S.², Bradley P.E.¹, O'Connor D.T.³, Slifka A.J.¹, Drexler E.S.¹

¹National Institute of Standards and Technology, 325 Broadway, Boulder CO 80305

²National Institute of Standards and Technology, 100 Bureau Dr, Gaithersburg, MD 20899

³Cold Regions Research and Engineering Laboratory, 72 Lyme Road, Hanover, NH 03755

Hydrogen is desirable for energy storage as it is cleaner burning and can store a larger amount of energy than an equal mass of gasoline. One problem related to the development of a hydrogen economy is to find or develop materials that ensure the safe, reliable, and cost-effective flow of energy from the source to the user. It is expected high-strength steels will be needed to serve this function. However, the existing network of natural gas pipeline, for example, is constructed of ferrous materials which are susceptible to embrittlement and subsequent increased fatigue crack growth rates (FCGR) during exposure to hydrogen. Proposed mechanisms of hydrogen embrittlement include hydrogen-enhanced decohesion (HEDE) and the hydrogen-enhanced localized plasticity (HELP) mechanisms. In the HEDE mechanism, accumulation of hydrogen at locations of high triaxial stresses lead to the weakening of Fe-Fe bonds once the hydrogen concentration reaches a critical concentration. In the HELP mechanism, the introduction of hydrogen gas creates areas of extended dislocations in the Fe lattice and enhances dislocation mobility in the steel framework.

Quantifying stress and strain fields from fatigue cracking is crucial to the determination of the underlying mechanism behind hydrogen embrittlement and to the study of hydrogen embrittlement and hydrogen-assisted FCGR. Because of the fast diffusion of H₂ from the steels, the effect of hydrogen embrittlement presents only during exposure, and steel specimens will exhibit in-air fatigue crack growth rates shortly after being removed from a hydrogen environment (~ 45 min.). Thus, any measurements designed to study hydrogen embrittlement and hydrogen-enhanced fatigue crack growth must be performed in situ.

We performed neutron transmission Bragg-edge measurements at the NIST Center for Neutron Research NG-6 beamline to characterize the strain fields near cracks that were grown both in air and in hydrogen. Using a novel chamber uniquely compatible with neutron scattering, the measured cracks were grown *in situ* during the neutron scattering measurements. An enhancement in the magnitude and spatial extent of the strain field near the crack grown in hydrogen compared to near the crack grown in air was observed. We compare the strain fields to predictions from finite element, and discuss the differences between the measured in-air and in-H₂ crack-tip strain fields in the context of the HELP and HEDE mechanisms.

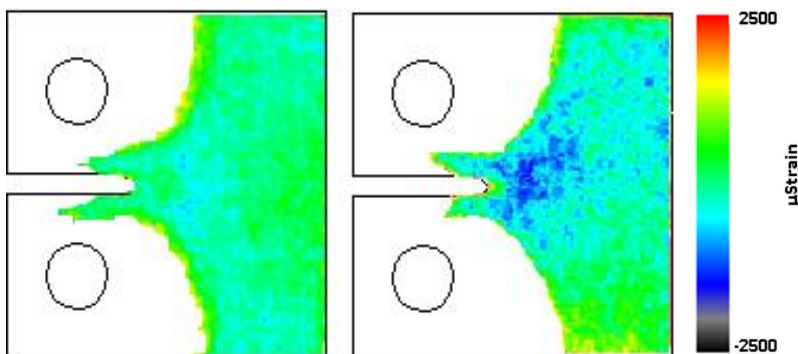

Figure 1: Measured strain fields for the cracks grown in air (left) and in H₂ (right). The strain direction measured is in the direction of the through-thickness of the CT specimen. An enhancement in the magnitude of the strain field near the fatigue crack grown in hydrogen of ~1.7x the strain field near the crack grown in air was observed. This is consistent with the HEDE mechanism.

Improvement of a Neutron Source and a Beam Line for Pulsed Neutron Imaging at KURRI-LINAC

Y. Takahashi¹, Y. Kiyonagi², A. Uritani², J. Hori¹, T. Sano¹, H. Unesaki¹, K. Nakajima¹

¹Research Reactor Institute, Kyoto University, Kumatori, Osaka 590-0494, Japan

²Nagoya University, Nagoya, Aichi 464-8603, Japan

A fast reactor system with trans-uranium (TRU) fuels containing minor-actinide (MA) is expected to be effective for the incineration of high-level radioactive wastes. For the safety operation of a fast reactor system, integrity evaluations of the fuels with high activity are required. In order to develop the new technology applicable to the integrity evaluation, the N-DeMAIN (Development of Non-Destructive Methods Adapted for Integrity test of Next generation nuclear fuels) project has been started in Japan. In the project, the neutron resonance transmission analysis (NRTA) is adopted for the identification and quantification of nuclides in the fuels by time-of-flight (TOF) measurement. In addition, the determination of temperature distribution in the fuels based on Doppler-effect and neutron imaging of each nuclide are conducted in the project.

The electron accelerator in Kyoto University Research Reactor Institute (KURRI-LINAC) will be used for the project because KURRI-LINAC is the only pulsed neutron facility where nuclear materials can be utilized in Japan. The neutron source and neutron transport line, namely moderator, reflector and collimators in the beam line, is being re-designed by simulation calculations using PHITS code and JENDL-4.0. And the experiments were conducted in the newly developed neutron source and beam line for quantitative analysis of the performances of the neutron source and beam line.

Acknowledgement

The authors thank Ms. Harada for her contribution of the simulation calculations and valuable discussion. Present study includes the result of “Development of Non-Destructive Methods Adapted for Integrity test of Next generation nuclear fuels” entrusted to the Kyoto University by the Ministry of Education, Culture, Sports, Science and Technology of Japan (MEXT).

Developing key capabilities for neutron imaging at ESS Using the ESS Testbeamline at HZB

Robin Woracek¹, Ken H. Andersen¹, Michael Wedel¹, Markus Strobl^{1,2}

¹ European Spallation Source ESS AB, SE-221-00, Lund, Sweden

² Paul Scherrer Institut, CH-5232 Villigen-PSI, Switzerland

The European Spallation Source (ESS) operates a time-of-flight testbeamline (V20) at Helmholtz Zentrum Berlin. The beamline serves several purposes:

- Development and testing of key ESS technologies (centralized timing system, instrument control, data reduction, detectors, neutron optical devices, ...)
- Development of cutting edge neutron methods (in collaboration with in-kind and external partners)

ESS will be the world's most powerful pulsed neutron source, while its long pulse time structure poses significant differences for several neutron methods. In order to address the required developments, V20 is capable of mimicking the ESS pulse structure by a double chopper system (14 Hz, 2.86 ms) and of pulse shaping via a wavelength frame multiplication (WFM) chopper system (similar to several ESS instruments, including ODIN).

We will report on recent progress and applications (related to neutron imaging) since Neuwave-8, including [key collaborators in brackets]:

- Progress on ESS technology integration [DMSC, RAL] + detector testing and development [HZG, UC Berkeley, Proxivision],
- Spin-echo modulated small-angle neutron scattering (SEMSANS) [TU Delft, PSI]
- Wavelength resolved Grating Interferometry [PSI]
- Fermi Chopper characterization using an imaging detector [FZJ, UC Berkeley]
- Pilot studies on energy devices [DTU, RAL, UCL, PSI]

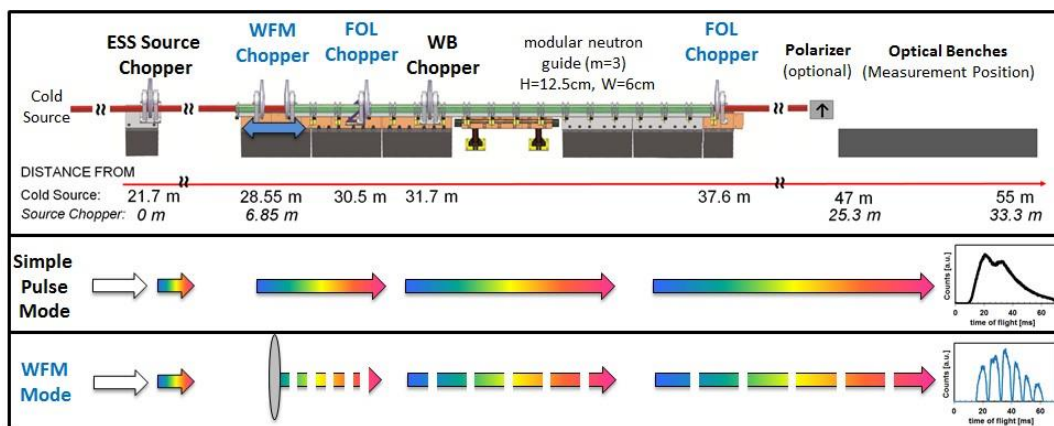

Figure: (TOP) Layout of V20 (CENTER) Illustration of simple pulsed mode [wavelength range 1.8Å-10Å, wavelength resolution ~ 10%] (BOTTOM) Illustration of the six-fold WFM mode [providing tunable wavelength resolution of 0.5%-2%]

References:

- [1] M. Strobl, M. Bulat, K. Habicht, Nucl. Instr. Meth. A 705 (2013)
 [2] R. Woracek, R. Woracek, T. Hofmann, M. Bulat, M. Sales, K. Habicht, K. Andersen, M. Strobl, Nucl. Instr. Meth. A 839 (2016)

Towards polarized neutron microscope for studies of magnetic domains and magnetic phase transitions

B. Khaykovich¹, A. Delmore², D. S. Hussey³, P. Jorba⁴, N. Kardjilov⁵, L. Riik⁵, M. Schulz^{4,6}, W. Treimer^{5,7}, R. Ziesche^{5,8,9}

¹Nuclear Reactor Laboratory, Massachusetts Institute of Technology, Cambridge, MA, USA; ²Department of Nuclear Science and Engineering, Massachusetts Institute of Technology, Cambridge, MA, USA; ³Physical Measurement Laboratory, NIST, Gaithersburg, Maryland, USA; ⁴Physik-Department, Technische Universität München, Garching, Germany; ⁵Helmholtz-Zentrum Berlin für Materialien und Energie, Berlin, Germany; ⁶Heinz Maier-Leibnitz Zentrum, Technische Universität München, Garching, Germany; ⁷University of Applied Sciences, Beuth Hochschule f. Technik, Berlin, Germany; ⁸Department of Chemical Engineering, University College London, London, UK; ⁹STFC, Rutherford Appleton Laboratory, ISIS Facility, Chilton, UK

Neutron imaging of magnetic phenomena is very promising being the only imaging technique, which is able to probe the spatial distribution of magnetic domains in the bulk of materials. We used a combination of polarized imaging and grating interferometry to study magnetic transitions and domain structures in single crystals of rare earth magnets, Ho and Tb. However, imaging magnetic phenomena is challenging since it requires polarized or phase imaging techniques, which involve special equipment restricting both the neutron flux and the spatial resolution.

Particularly in the case of the depolarization imaging, a spin analyzer is placed between the sample and the detector, limiting the spatial resolution to ~120 microns. Since interesting magnetic domains are often a few microns or less in size, the resolution needs to be increased significantly. Also, interesting magnetic materials are often available only in the form of very small single crystals.

Therefore, we have proposed and demonstrated a new approach, the polarized neutron microscope, where Wolter optic is used as image-forming lens, allowing to place the spin analyzer and other sample environment without affecting the resolution. We observed spatial inhomogeneity in the magnetic phase transition in a sub-mm sample of HgCr₂Se₄ crystal inside a clamp pressure cell at cryogenic temperatures. This demonstration shows that the use of image-forming optics has the potential to transfigure neutron imaging applications beyond magnetic imaging.

Three Dimensional Polarimetric Neutron Tomography of Magnetic Fields

Morten Sales¹, Markus Strobl^{2,3}, Takenao Shinohara⁴, Anton Tremsin⁵, Luise Theil Kuhn⁶,
William R.B. Lionheart⁷, Naeem M. Desai⁷, Anders BJORHOLM DAHL⁸, and Søren Schmidt¹

*1*Department of Physics, Technical University of Denmark, Denmark; *2*European Spallation Source ESS ERIC, Sweden;
*3*Niels Bohr Institute, University of Copenhagen, Denmark; *4*J-PARC Center, Japan Atomic Energy Agency, Japan;
*5*Space Sciences Laboratory, University of California at Berkeley, USA; *6*Department of Energy Conversion and Storage,
Technical University of Denmark, Denmark; *7*School of Mathematics, The University of Manchester, United Kingdom;
*8*Department of Applied Mathematics and Computer Science, Technical University of Denmark, Denmark

We present our successful demonstration of the novel technique Time-of-Flight Three Dimensional Polarimetric Neutron Tomography (ToF 3DPNT) for the non-destructive measurement and reconstruction of three dimensional magnetic field strengths and directions, a technique capable of extracting hitherto un- measurable properties from bulk samples.

Using a state-of-the-art polarimetric set-up for ToF neutron instrumentation at the J-PARC RADEN beamline, Japan, in combination with a newly developed reconstruction algorithm, we have measured and reconstructed the magnetic field generated by a current carrying solenoid as displayed in the figure.

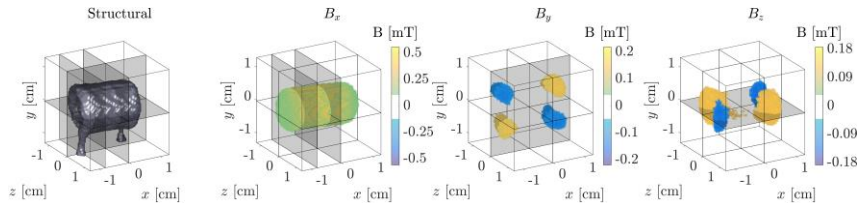

Three Dimensional Polarimetric Neutron Tomography of Magnetic Fields.

References:

M. Sales et al. Submitted. (see also arXiv:1704.04887)

Study of shape dependent flux trapping with polarized neutrons

W. Treimer^{1,2}, H. Höppner^{1,2}, J. Nicol³, L. Riik^{1,2}, R. Ziesche⁴

¹University of Applied Sciences, Beuth Hochschule f. Technik, FB II, D -13353 Berlin, Germany

²Helmholtz Zentrum für Materialien und Energie, D-14109 Berlin, Germany ³Imperial College London, Department of Mechanical Engineering, London, SW7 2BX, UK ⁴University College London, Department of Chemical Engineering, London WC1E 7JE, UK

In the past radiography and tomography from the trapped magnetic fields in superconductors recorded with polarized neutrons have proven to be a unique technique in order to determine their shape and amount for different $T < T_c$. [1-2] There, specially measured and quantized T- dependences could be realized and showed thermodynamics of superconductivity below T_c .

However, physics of flux trapping is still not fully understood due to lack knowledge of parameters which contribute / influence flux trap. Inhomogeneities are well accepted candidates, but shape and orientation of a sample with respect to an external magnetic field during cooling process also play an important role for flux trap as well as amount and temperature $T < T_c$ of the sample.

The underlying question here is the role of geometry of a sample in the Meissner phase / intermediate state in the case of flux trap. We report about series of measurements with different samples and geometries and try to give an answer for this issue.

References

- [1] W. Treimer, O. Ebrahimi, N. Karakas, R. Prozorov, Phys. Rev. B **85**, 184522-1 - 9 (2012)
- [2] W. Treimer, J. Magnetism and Magnetic Materials **350**, p 188-198 (2014)

Present status of neutron imaging detector development at RADEN

J.D. Parker¹, M. Harada², H. Hayashida¹, T. Kai², Y. Matsumoto¹, T. Nakatani²,
K. Oikawa², M. Segawa², T. Shinohara², Y. Kiyanagi³

¹ Comprehensive Research Organization for Science and Society (CROSS), Tokai, Ibaraki 319-1106, Japan

² Japan Atomic Energy Agency (JAEA), Tokai, Ibaraki 319-1195, Japan

³ Nagoya University, Nagoya, Aichi 464-8603, Japan

The Energy-Resolved Neutron Imaging System, RADEN [1], located at beam line BL22 of the J-PARC Materials and Life Science Experimental Facility (MLF), is designed to take full advantage of the high-intensity pulsed neutron beam of the MLF to perform both conventional radiography/tomography and energy-resolved neutron imaging techniques. To meet the very different requirements for these imaging techniques, we provide a wide selection of detector systems, from traditional and high-speed CCD cameras to cutting-edge micro-pattern detectors. In this presentation, we will discuss the present status of ongoing detector development at RADEN, including recent progress for our CCD camera system [2], Micro Pixel Chamber-based Neutron Imaging Detector (μ NID) [3], and Li-glass scintillator detector (LiTA12) [4], among others. Through improvements and upgrades to the CCD camera system, we have achieved a spatial resolution of 50 μ m and successfully performed stroboscopic imaging. For the μ NID, we have tested a boron-coated drift cathode as a possible replacement for the ³He gas currently used. We have also tested new readout elements and made improvements to the data analysis for improved spatial resolution and rate performance. Additionally, a new μ NID system with a more compact pressure vessel and new data acquisition controller unit with increased functionality has been built and tested at RADEN. Finally, we have carried out suitability studies of a flat-panel Li-glass scintillator detector for resonance absorption imaging. The results of recent on-beam tests of these detector systems performed at the MLF will be presented.

References

- [1] T. Shinohara *et al.*, J. Physics: Conf. Series **746**, 012007 (2016).
- [2] Y. Matsumoto *et al.*, to be published in Physics Procedia.
- [3] J.D. Parker *et al.*, Nucl. Instr. and Meth. A **726**, 155 (2013).
- [4] S. Satoh *et al.*, JPS Conf. Proc. **8**, 051001 (2015).

Optimizing the design and use of neutron imaging facilities: A) Is a Sapphire filter helpful for neutron imaging? B) Maximizing the utilization of neutron imaging beam time by multiple detection systems

Burkhard Schillinger

Heinz Maier-Leibnitz Zentrum (FRM II), Technische Universität München

Neutron imaging facilities have seen a lot of optimization in the past decade, and further optimization becomes more and more complicated. While many scattering instruments use a sapphire filter for the suppression of fast neutrons, it was never clear if neutron imaging would benefit from the use of such a filter. Then, the trend in neutron imaging goes towards smaller samples and higher resolution while the original beam was designed for a cross section in the order of 20x20 cm², so a lot of neutrons are wasted during the examination of cm-sized samples.

A) According to many colleagues with scattering instruments, typical thicknesses from 10 to 15 cm cause significant improvement. For neutron imaging, sapphire filters are sometimes used ‘on suspicion’, and integrated into the beam channel, so they cannot easily be removed to check their effect. We have explicitly tried 10 pieces of aligned 1 cm Sapphire blocks at the ANTARES imaging facility of FRM II using a Gadox scintillation screen, both with the full beam as well with epithermal neutrons still transmitted with the fast shutter closed. The filter crystals were once mounted on a rotation table close to the detector, and once far away from the detector, close to the collimator, in about 8 m. We have seen a reduction in intensity of about 0.33, which remained constant even with a +/-10° angular scan, for both spectra. Local gamma dose within our bunker increased only with the filter present in the bunker, but fast neutrons would have transmitted the detector and been absorbed only in the beam catcher seven meters away. We examined the relative contrast between dark and bright of a Siemens star made of Gadolinium, and it remained the same as in the full beam with all crystal configurations. We have not seen any effect on image quality and relative contrast in the cold and epithermal range. If there was an effect on the fast flux, we were not sensitive for it. The talk will explain the exact experimental conditions and show the single results; we kindly ask the audience to discuss the setup for possible mistakes, and/or if we should finally conclude that a Sapphire filter only reduces the available intensity for imaging and does not improve the image quality.

B) Neutron Imaging has seen a rapid development towards high resolution in time and space. The current trend goes to smaller and smaller samples with higher and higher resolution, so detectors view only a very small beam area. The downside of this development is that the total neutron flux on the whole detector area also becomes smaller and smaller, increasing the required measuring times and throwing most of the neutron flux on the originally large area away. Setups have been built by PSI and FRM II to record multiple tomographies on one imaging detector using multiple rotation axes for narrow, but elongated samples at the same time. But often, the remaining resolution of the split detector area is insufficient for the samples at hand. Even if most facilities have one central, high end detection system, a slight deterioration in quality may well be traded for the examination of a larger number of samples. For high resolution only, a detection system (including shielding) can be built much smaller than the flexible, universal-size camera boxes, so we propose to set up four or more small detection systems including CT axes that make use of the large original beam cross section for four or more simultaneous high-resolution tomography measurements. Since the exposures of the cameras and also the rotation of samples will be synchronized, it is also possible to stack two samples for two camera systems within an Aluminium tube with cutouts on a single rotation table, so a 2x2 camera array can be served with only two rotation stages. Especially for pulsed neutron imaging at spallation sources, where the price for a time-resolved imaging detector with channel plates is small compared to the construction cost of the whole facility, and the separation of a pulse into time slices further increases the required measuring time, the use of multiple detection systems will optimize the use of the available beam time. A prototype using a small camera is currently under development at ANTARES / FRM II, and the control software is being modified to control four rotation tables and four cameras with identical parameters. The talk will describe several theoretical aspects both in hard- and software, and hopefully, by the time of the meeting, present the first prototype of a multiple system.

Double-crystal monochromator device for energy-selective imaging

Alaa M. Al-Falahat, Tran V. Khanh, Nikolay Kardjilov, Robin Woracek, Mirko Boin, Ingo Manke
Helmholtz-Zentrum Berlin, Hahn-Meitner-Platz 1, 14109 Berlin, Germany

Three techniques for beam monochromatisation in neutron imaging experiments can be used. Double crystal monochromator (DCM) and velocity selector (VS) are used at steady neutron sources (reactors) while Time of Flight (TOF) technique is used usually at pulsed sources. In the first case, the wavelength resolution $\Delta\lambda/\lambda$ varies between 3 % and 10 % (DCM) and between 10 % and 30 % (VS), while in case of TOF a resolving power $\Delta\lambda/\lambda \sim 10^{-3}$ can be achieved, which is sufficiently accurate to detect residual stresses in samples with simple geometries.

A comparison between different techniques is presented in Figure 1 where the energy- selective transmission of iron sample is measured by using a velocity selector and double-crystal monochromator with two different crystal mosaicity. The attenuation spectra are compared with tabulated data for iron.

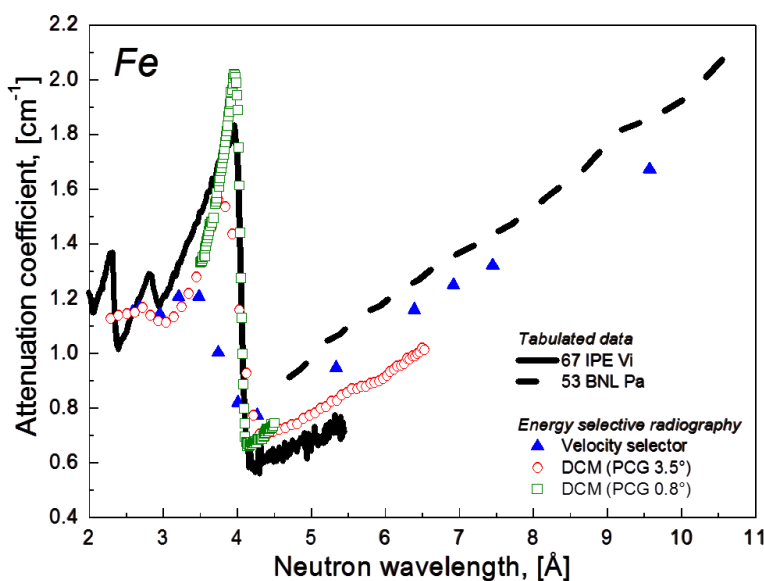

Fig. 1 Energy-selective dependence of the attenuation coefficient for iron measured by velocity selector (blue) and double crystal monochromator with two different crystals (pyrolytic graphite) with mosaicities of 3.5° and 0.8°. Tabulated data are given in black.

Double crystal monochromator devices were installed recently and operated successfully at various imaging facilities. The optimization of these facilities is performed on empirical base by varying the setup parameters following the trial and error strategy. In order to understand the behavior and the principle of the double-crystal monochromator device Monte Carlo simulations based on McStass code were performed and analyzed.

Development of polarized neutron imaging technique on CG-1D beamline for the investigation of superconductors and magnetic transitions

I. Dhiman¹, Ralf Ziesche^{2,3}, Tianhao Wang¹, Hassina Bilheux¹, Lou Santodonato¹, X. Tong¹, C. Y. Jiang¹, Ingo Manke², Wolfgang Treimer², Tapan Chatterji⁴, and Nikolay Kardjilov²

¹ Neutron Science directorate, Oak Ridge National Laboratory, Tennessee 37831, USA, ² Helmholtz Centre Berlin for Materials and Energy, D-14109 Berlin, Germany ³ Department of Chemical Engineering, UCL, Torrington Place, London WC1E 7JE, UK, ⁴ Institute Laue-Langevin, 38042 Grenoble Cedex, France.

Magnetically aligned polarized neutron imaging is a novel probe for the investigation of magnetic materials. Direct sensitivity of neutrons to the magnetic field distribution in and around samples can make substantial contribution in the field of superconductivity and magnetism [1-3]. Neutron spin passing through an inhomogeneous magnetic field experiences different Larmor precessions, which is dependent on path integral. This path-dependent depolarization effect of the neutron spin can be used to image the influence of magnetic field in superconductors. Neutron spin interaction with magnetic fields provides the possibility to explore bulk of materials, as against various other techniques such as magneto-optical imaging, surface based scanning tunneling microscopy techniques.

Type-I superconductors do not exhibit built-up of flux lines in contrast to type-II superconductors, on application of external magnetic field. However, studies have been reported about the development of an additional state [1, 2] and quantum tunneling of interfaces in Pb (type-I superconductor) samples [3].

Our aim is to develop polarized neutron imaging technique at CG-1D beamline, and study various superconducting samples, with varying magnetic field and temperature. Towards this, we have carried out polarized neutron imaging proof-of-concept using polychromatic neutron beam at the ORNL HFIR CG-1D beamline. Using polychromatic neutron beam, the exposure time is considerably improved on the order of minutes in comparison to hours of exposure time for monochromatic beam. To demonstrate the capability of this technique, we investigate two samples, Iron Platinum (Fe₃Pt) and Niobium (Nb). Firstly, ferromagnetic phase transition is studied for Fe₃Pt sample as a function of temperature, wherein a clear phase transition from ferromagnetic to paramagnetic state is observed at $T_C \sim 450$ K. Secondly, the mixed state with flux pinning behavior in Niobium type-II superconductor in the presence of external magnetic field of 15 mT is investigated. Signatures of magnetic flux pinning behavior are observed below the transition temperature of $T_C \sim 9.2$ K.

References:

1. R. Prozorov, A. F. Fidler, J. R. Hoberg, & P. C. Canfield, Nature Physics **4**, 327 (2008).
2. W. Treimer, O. Ebrahimi, N. Karakas, & R Prozorov ; Phys. Rev B **85**, 184522 (2012).
3. S. Vález, R. Zarzuela, A. García-Santiago & J. Tejada; Phys. Rev. B **85**, 064506 (2012).

Acknowledgement

This research used resources at the High Flux Isotope Reactor, a DOE Office of Science User Facility operated by the Oak Ridge National Laboratory. This material is based upon work supported by the Office of Basic Energy Sciences, U.S. Department of Energy.

Complementary information: Ultra small angle scattering and radiography with polarized neutrons on magnet steel samples

L. Riik,^{1,2} H. Höppner,^{1,2} W. Treimer,^{1,2} and R. Ziesche^{1,3,4}

¹Helmholtz-Zentrum Berlin für Materialien und Energie, D-14109 Berlin, Germany

²University of Applied Sciences Berlin Beuth Hochschule für Technik Berlin, D 13353 Berlin, Germany ³Department of Chemical Engineering, University College London, Torrington Place, London WC1E 7JE, UK ⁴STFC, Rutherford Appleton Laboratory, ISIS Facility, Chilton, OX11 0QX, UK

A new instrument is developed that combine ultra small angle scattering with the additional use of polarized neutrons which give a unique tool to investigate spin depending scattering. The spin up and down components are spatial separated by an inhomogeneous field of an electromagnet. Thus, allowing to analyse scattering of both components separately which is done by a fivefold reflection analyser crystal. A separation of 50 seconds of arc and polarization degree up to 0.9992% is realized. The angle sensitivity of neutron spin relative to scattering plane is less than 0.2° and as a result enabling an accurate determination of the incident spin. This technique will be used to gain complementary information to polarized neutron imaging plates which was employed to visualize and locate magnetic domains in magnetic steel plates. Polarized neutron imaging use spin precession and the direction of magnetic domains can only be guessed by assumptions and simulations [1]. On the other hand the new instrument give information of spin dependent scattering at magnetic domains which add up to the nuclear scattering [2] and therefore precise information of the magnetic field direction in the domain in the magnetic steel plate.

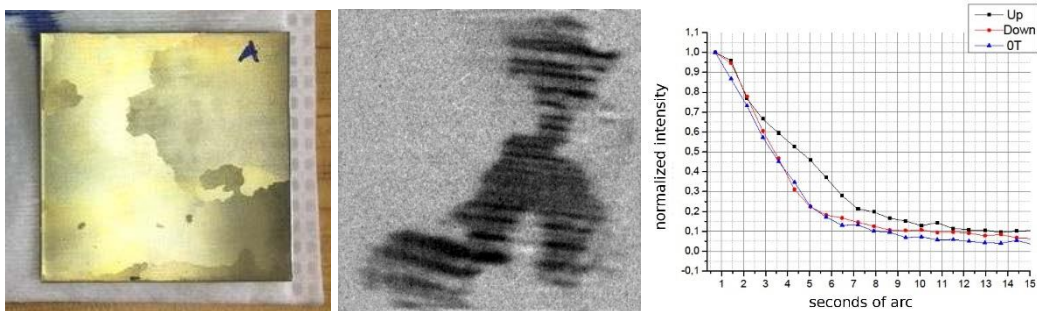

FIG. 1: left: FeSi plate, middle: PNI showing domain structure, right: ultra small angle scattering with unpolarized(blue curve) and polarized neutrons(up(black) and down(red))

References:

- [1] Treimer; Radiography and tomography with polarized neutrons; Journal of Magnetism and Magnetic Materials 350 (2014) 188-198
- [2] Bacon; Neutron Diffraction; Oxford At The Clarendon Press 1955, p. 147ff

Quantitative determination and visualization of the magnetic induced phase shift with polarized neutron grating interferometry

J. Valsecchi^{1,2}, R. P. Harti^{1,2}, F. Piegsa³, W. Treimer^{4,5}, E. Lehmann¹, and C. Grünzweig¹

¹Paul Scherrer Institut, CH-5232 Villigen PSI, Switzerland ²Université de Genève, CH-1211 Genève, Switzerland

³LHEP Universität Bern CH-3012, Bern, Switzerland ⁴Helmholtz-Zentrum Berlin, D-14109, Berlin, Germany

⁵University of Applied Sciences Beuth Hochschule, D-13353, Berlin, Germany

Over the last decade polarized neutron imaging [1] and the grating interferometer technique (nGI) [2] have gained attention among the neutron imaging community due to their spatial resolution and sensitivity to the magnetic structure.

Here we present an extension of the classical nGI setup, which allows to operate with polarized neutrons (p-nGI) in order to retrieve differential phase contrast images (DPCI) induced by the interaction between the neutron spin and the magnetic field.

The DPCI yields quantitative information about the phase shift induced by the refraction of the polarized neutron beam on the phase object, due to the magnetic interaction between the sample and the neutron spin state, hence the magnetic field distribution.

The talk reports our experimental results achieved at the Beamline for neutron Optics and other Application (BOA) [3] at Paul Scherrer Institut (PSI).

A beryllium filter was used as energy selector in order to improve the sensitivity of the setup to the magnetic field strength.

The tailored sample, taken into account for our experiment, was the magnetic field produced by square-shaped neodymium permanent magnets, roughly 0.9 T.

Hence, the magnetic phase shift image (PCI) of the experimental data was achieved by integrating the DPCI, taking into account the energy spectrum of the beam and the visibility response function [4] of the p-nGI setup.

Subsequently, the PCI results were validated with the expected value calculated from the Hall probe measurements.

References

[1] Kardjilov N. et al. (2008) Nat. Phys. 4, pp 399-403, doi:10.1038/nphys912

[2] Pfeiffer F. et al. (2006) Phys. Rev. Lett. 96, 215505, doi:10.1103/PhysRevLett.96.215505

[3] Morgano M. et al. (2014) Nucl. Instr. and Meth. A 754, doi:10.1016/j.nima.2014.03.055 [4] Harti R. P. et al. (2017) Opt. Express. 1023 Vol.25 No.2, doi:10.1364/OE.25.001019

Three Phase-Grating Moiré Neutron Interferometer

D. Sarenac,^{1,2} D.A. Pushin,^{1,2} M. Huber,³ D.S. Hussey,³ H. Miao,⁴ M. Arif,³
D.G. Cory,^{2, 5, 6, 7} A.D. Cronin,⁸ D. Jacobson,³ J. LaManna,³ and H. Wen⁴

¹Department of Physics, University of Waterloo, Waterloo, ON, Canada, N2L3G1; ²Institute for Quantum Computing, University of Waterloo, Waterloo, ON, Canada, N2L3G1; ³National Institute of Standards and Technology, Gaithersburg, MD 20899, USA; ⁴Biophysics and Biochemistry Center, National Heart, Lung and Blood Institute, National Institutes of Health, Bethesda, MD USA; ⁵Department of Chemistry, University of Waterloo, Waterloo, ON, Canada, N2L3G1; ⁶Perimeter Institute for Theoretical Physics, Waterloo, ON, Canada, N2L2Y5; ⁷Canadian Institute for Advanced Research, Toronto, Ontario, Canada, M5G 1Z8; ⁸University of Arizona, Department of Physics, Tucson, AZ, USA, 85721

We have demonstrated a three phase-grating neutron interferometer operating in the far field regime and with a polychromatic beam. The technique builds upon the two phase-grating moiré interferometer allowing for large grating separations and increased sensitivity to phase gradients. Interference fringes were observed with a total grating separation of four meters. The three phase-grating moiré neutron interferometer is a suitable candidate for large area neutron interferometer applications due to its relaxed grating fabrication and alignment requirements and broad wavelength acceptance. In this talk I will discuss a proposed experiment to measure the gravitational constant “G”.

A Neutron Interferometer (NI) has proven to be an extremely sensitive measuring tool; allowing for the precise characterization of material properties as well as the fundamental laws of nature. However, a successful perfect crystal neutron interferometer is extremely difficult to fabricate and requires stringent forms of vibration isolation, beam collimation, and alignment. In addition, these types of interferometers are limited to the available float-zone grown silicon ingots which typically are limited to a length of a few inches.

Recently we demonstrated a broadband three phase-grating neutron interferometer operating in the far field. This NI setup employs the universal moiré effect [1] and is an extension to the recently demonstrated two phase-grating moiré interferometer [2, 3]. The first two gratings form an achromatic Fourier image at a plane downstream, and then the third grating is optimized with the Fourier image for the universal moiré condition. This allows for large grating separations and hence increased sensitivity towards phase gradients.

The neutron three phase-grating interferometer can be viewed as a spatially separated array of Mach-Zehnder (MZ) neutron interferometers; with the path separation of each MZ interferometer determined by the period of the gratings. This is a coherent process, and the universal moiré pattern condition provides us with an ability to use a polychromatic beam and maintain the coherence. The advantages of this setup include the use of widely available thermal and cold neutron beams, relaxed grating fabrication and alignment requirements, large interferometer area, and broad wavelength acceptance.

One of the significant applications of three phase-grating moiré interferometer would be a high resolution measurement of the gravitational constant, G. The high sensitivity to phase gradients allows for an experiment similar to well-known perfect crystal neutron interferometer experiment to measure the phase shift of neutrons caused by their interaction with Earth’s gravitational field [4]. With a dedicated robust three grating NI setup running for a period of 1 year yields us the possibility of measuring $\delta g/g$ to a 10^{-11} and thus $\delta G/G$ to a 10^{-5} level or smaller.

References:

- [1] H. Miao, A. Panna, A.A.Gomella, E.E. Bennett, S. Znati, L. Chen, and H. Wen, Nature Physics (2016).
- [2] D. Pushin, D. Sarenac, D. Hussey, H. Miao, M. Arif, D. Cory, M. Huber, D. Jacobson, J. LaManna, J. Parker, et al., Physical Review A 95, 043637 (2017).
- [3] D.S. Hussey, H. Miao, G. Yuan, D. Pushin, D. Sarenac, M.G. Huber, D.L.Jacobson, J.M. LaManna, and H. Wen, arXiv preprint arXiv:1606.03054 (2016).
- [4] R. Colella, A.W. Overhauser, and S.A. Werner, Physical Review Letters 34, 1472 (1975).

Schedule for Wednesday, 14 JUN 2017

| Start | End | Session | Speaker | Title |
|-------|-------|--------------------------------|-----------------------------|---|
| 8:30 | 9:00 | Arrive | | |
| 9:00 | 9:20 | <i>Tomography</i> | Jacob LaManna | Status and research applications of the Neutron and X-ray Tomography (NeXT) system |
| 9:20 | 9:40 | | Anna Fedrigo | Bi-modal tomography with X-rays and neutrons, a case study on impactite samples |
| 9:40 | 10:00 | | Muhammad Abir | Post Irradiation Examination of U-Mo Fuels Using Neutron Computed Tomography |
| 10:00 | 10:20 | | Singanallur Venkatakrishnan | Pushing the Limits of 3D Imaging Systems - A Model-based Reconstruction Approach |
| 10:20 | 10:50 | Coffee | | |
| 10:50 | 11:10 | <i>Bragg Edge Applications</i> | Daisuke Ito | Bragg edge imaging of solidification process in lead-bismuth eutectic |
| 11:10 | 11:30 | | Gian Song | Dynamic microstructural evolution of additively manufactured Inconel 718 parts using Bragg-edge imaging radiography and neutron diffraction |
| 11:30 | 11:50 | | Malgorzata Makowska | Coupling between creep and redox behaviour in half-SOC cells observed in-situ by Bragg edge neutron imaging |
| 11:50 | 12:10 | | Tetsuya Kai | Observation of lithium-ion battery by using the Bragg-edge imaging technique |
| 12:10 | 12:30 | | Eberhard Lehmann | Progress in Neutron Imaging (during/by the NEUWAVE workshop series) |
| 12:30 | 13:30 | Lunch | | |
| 13:30 | 14:00 | Transit to NCNR | | |
| 14:00 | 16:00 | NCNR Tour | | |

Status and research applications of the Neutron and X-ray Tomography (NeXT) system

Jacob M. LaManna, Daniel S. Hussey, Eli Baltic, David L. Jacobson

Physical Measurement Laboratory, National Institute of Standards and Technology, Gaithersburg, MD, USA

Neutrons and X-rays provide complementary non-destructive probes for the analysis of structure and chemical composition of materials. Due to the high sensitivity to hydrogen, neutrons excel at separating liquid water or hydrogenous phases from the underlying structure while X-rays resolve the solid structure. Many samples of interest, such as fluid flow in porous materials or curing concrete, are stochastic or slowly changing with time which makes sequential imaging with neutrons and X-rays difficult as the sample may change between scans. To alleviate this issue, NIST has developed a system for simultaneous neutron and X-ray tomography (NeXT) by orienting a 90 keV_{peak} micro-focus X-ray tube orthogonally to a thermal neutron beam. The NeXT system allows for non-destructive, multimodal tomography of dynamic or stochastic samples while penetrating through sample environment equipment such as pressure and flow vessels. This talk will focus on recent instrument developments and give examples of several application areas.

Bi-modal tomography with X-rays and neutrons, a case study on impactite samples

A. Fedrigo^{1,2}, K. Marstal^{2,3}, C. Bender Koch⁴, M. Lyksborg², A. Bjorholm Dahl², C. Gundlach⁵, and M. Strobl¹

¹ European Spallation Source ESS ERIC, SE-221 00 Lund, Sweden; ² DTU Compute, Lyngby (DK); ³ ERASMUS MC - Biomedical Imaging Group Rotterdam (NL); ⁴ Copenhagen University, Copenhagen (DK); ⁵ DTU Physics, Lyngby (DK)

X-ray and neutron tomography are applied as a bi-modal approach for the 3D characterisation of heterogeneous geological samples containing high- and low-Z materials. In particular we investigated composition and porosity of Monturaqui and Wabar impactites, partially melt and glassy materials that formed by shock metamorphism during the impact of iron meteorites with the target rocks in Monturaqui crater (Chile) and target dune sands in Empty Quarter of Saudi Arabia.

Meteorite collisions cause irreversible geological changes in the target material due to the formation and propagation of a shock compressional wave in the target body. For terrestrial planets, the impact can increase pressures up to several 100 GPa and releases heat up to thousands degrees Celsius [1], causing rock deformations both at macroscopic and at microscopic level. Depending on the geochemistry of the target rocks and the pressures and temperatures reached, the materials involved may undergo melting, and even vaporisation. After the collision, melted and shattered rocks and meteorite fragments are ejected in various directions opening a crater cavity. The resulting impactite rocks represent chemical disequilibrium products where vitreous phases are mixed with shocked and unshocked lithic fragments, and vaporised/condensed metal spherules deriving from the meteorite, forming vesiculated heterogeneous aggregates.

Computed tomography is used as a non-destructive method of studying morphology and composition of the impactites, and distribution and size variability of the vesicles and metallic spherules. X-ray CTs were carried out at the 3D Imaging Centre, DTU Lyngby (DK), while white beam neutron tomographies were carried out at the IMAGINE beamline [2], the cold neutron imaging facility at the Laboratoire Léon Brillouin CEA/CNRS (FR). The two data sets have been scaled and aligned on a common coordinate system using a normalised mutual information coregistration method [3, 4], allowing for a pixel-wise comparison between images from the two different data sets. The dual attenuation value was used for material segmentation.

References:

- [1] Fettes D. & Desmons J. (2007) *Metamorphic Rocks: A Classification and Glossary of Terms*, Cambridge University Press, Cambridge, UK
- [2] www-llb.cea.fr/fr-en/pdf/Imagine.pdf
- [3] <http://www.fil.ion.ucl.ac.uk/spm/software/spm8/>
- [4] C. Studholme et al., *Pattern Recognition* **32**, 71–86, 1999.

Post Irradiation Examination of U-Mo Fuels Using Neutron Computed Tomography

Muhammad Abir, Aaron Craft, Walter Williams, Daniel Wachs

Materials and Fuels Complex, Idaho National Laboratory, P.O. Box- 1625, Idaho Falls, ID, USA

Idaho National Laboratory (INL) has a 250 kW TRIGA mark II neutron radiography (NRAD) reactor for neutron tomography of irradiated materials and fuels. INL utilizes an indirect foil-film transfer technique, offering a complete rejection of gamma radiation. Two neutron images of the highly irradiated U-Mo fuel were acquired by indirect foil-film transfer technique using indium and dysprosium foils after subsequent chemical processing of X-ray films. Indium and dysprosium foils provide two neutron images activated by epithermal and thermal neutrons, respectively. Since the acquisition of neutron images is a prohibitively time-consuming process, a limited-angle strategy is employed for CT reconstruction of U-Mo fuels.

The U-Mo monolithic fuels clad with AL 6061 aluminum with 4 full-length fuel plates (as shown in Fig. 1), each of them are approximately 101.6 cm long \times 6.28 cm wide \times 0.127 cm thick and are curved to a radius of 9.03 cm are used to demonstrate neutron tomography [1]. Each fuel plate has a nominal fuel meat thickness of 0.033 cm and a zirconium barrier thickness of 0.0025 cm on either side of the foil resulting a total foil thickness of 0.038 cm and a total plate thickness of 0.127 cm. The assembly was irradiated at the ATR for two full cycles with 95.6 effective full power days (EFPD).

The penetration depth of neutrons (which largely depends on the enrichment of U-235) through U-Mo fuel assemblies is calculated for both thermal and epithermal neutrons prior to conducting tomographic reconstruction. Calculations and prior studies reveal that thermal neutrons are best suited for tomography of small assemblies and low enriched fuels such as the U-Mo fuel assemblies (total plate thickness of 0.508 cm) [2]. Therefore, reconstruction of the U-Mo fuels is performed using radiographs produced with thermal neutrons. A total of 41 neutron radiographs were acquired and digitized using a flatbed image scanner. The angular range of the image acquisition is shown in Fig. 2(a). Fig. 2(b) shows a neutron radiograph acquired at 115°. 2D and 3D reconstructions (Fig. 2(c), (d), and (e)) are performed after subsequent image processing and using an algorithm developed for limited-angle reconstruction strategy [3].

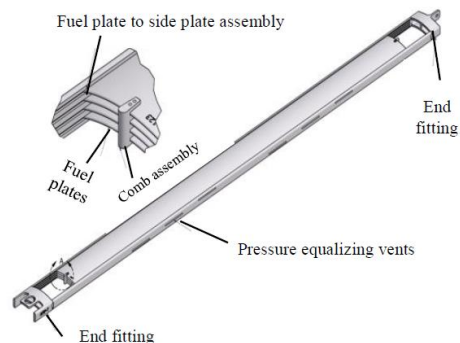

Fig. 1: U-10 Mo fuel assembly (19.75% ²³⁵U)

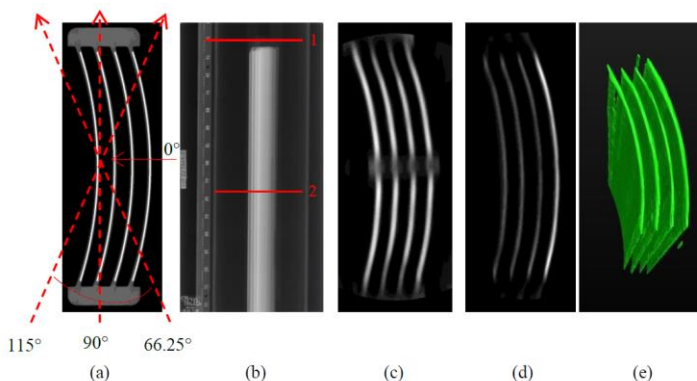

Fig. 2 (a) shows the acquisition angular range, (b) shows a neutron radiograph, (c) shows reconstruction from position 1, (d) shows reconstruction from position 2, (e) shows the 3D reconstruction of the assembly.

References

- [1] D. M. Perez, M. A. Lillo, G. S. Chang, G. A. Roth, N. E. Woolstenhulme, and D. M. Wachs, "AFIP-1 Irradiation Summary Report", Idaho National Laboratory (May 2011) Report INL/EXT-11-22045.
- [2] C. T. Oien, J. P. Barton, and C. F. Barton, "Feasibility of Epi-Thermal Neutron Radiography of Fast Reactor Fuel Assemblies," in *Neutron Radiography: Proceedings of the First World Conference San Diego, California, U.S.A. December 7-10, 1981*, J. P. Barton and P. von der Hardt, Eds., ed Dordrecht: Springer Netherlands, 1983, pp. 403-410.
- [3] M. I. Abir *et al.*, "Determination of optimal imaging parameters for the reconstruction of a nuclear fuel assembly using limited angle neutron tomography," *Journal of Instrumentation*, vol. 11, p. C01016, 2016.

Pushing the Limits of 3D Imaging Systems - A Model-based Reconstruction Approach

S. V. Venkatakrisnan^[1], Richard K. Archibald^[2], Hassina Billheux^[3], Philip Bingham^[1]

[1] Imaging, Signals and Machine Learning Group, Oak Ridge National Lab, [2] Computer Science and Mathematics Group, Oak Ridge National Lab, [3] High-Flux isotope Reactor and Spallation Neutron Source, Oak Ridge National Lab

Model-based iterative reconstruction (MBIR) approaches have gained popularity over the last decade for addressing challenges in tomographic (3D) reconstruction for various applications. These methods work by combing the physics and statistics of the data formation with low-dimensional models for the unknown volume to formulate the reconstruction as a high-dimensional (Bayesian) estimation problem that is solved in an iterative manner. In this work, we will present MBIR algorithms for tomographic reconstruction with an emphasis on applications in electron [1,2], X-ray [3] and neutron tomography [4]. We will address how these methods can be designed to automatically handle the presence of ring/streak artifacts and dramatically improve the quality of reconstructions from noisy (low-dose), limited and even time-resolved data compared to traditional approaches (like filtered back projection and SIRT). As a result, we can obtain high quality reconstructions even with miscalibrated, noisy detectors and sample environments that force novel acquisition geometries. Fig. 1 shows an illustration of the advantage of using MBIR for neutron tomography compared to the typically used iterative method. Finally, we will highlight the central challenges that remain in using these techniques in practice and touch upon some ideas on how to address them.

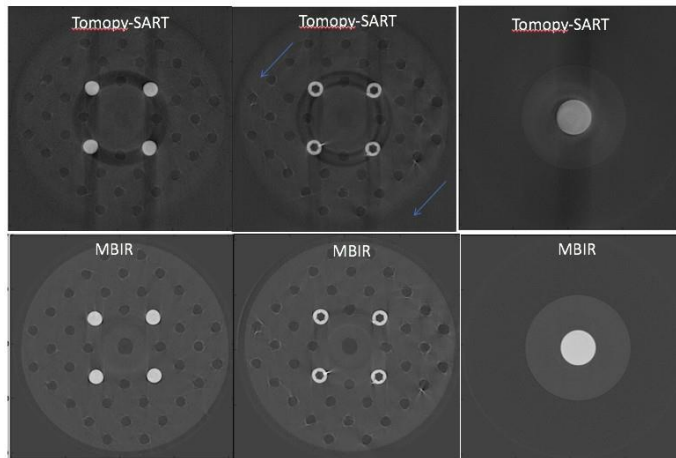

Fig.1. Cross-sections from reconstruction of a cylindrical sample mounted on a sample stage using a standard iterative method (using the tomopy package) and the proposed model-based technique. Notice that the artifacts are significantly reduced without any pre/post processing.

References

- [1] S. V. Venkatakrisnan, L.F. Drummy, M. Jackson, M. De Graef, J.P. Simmons, and C.A. Bouman, "Model-Based Iterative Reconstruction for Bright-Field Electron Tomography", IEEE Transactions on Computational Imaging, Vol. 1, Issue 1, pp. 1-15, March 2015
- [2] S. V. Venkatakrisnan, L.F. Drummy, M. Jackson, M. De Graef, J.P. Simmons, and C.A. Bouman, "A Model Based Iterative Reconstruction Algorithm for High Angle Annular Dark-Field Scanning Transmission Electron Microscope (HAADF-STEM) Tomography", IEEE Transactions on Image Processing, Vol. 22, Issue 11, pp. 4532-4544, Nov. 2013
- [3] K. Aditya Mohan, S. V. Venkatakrisnan, Lawrence F. Drummy, Jeff Simmons, Dilworth Y. Parkinson, and Charles A. Bouman, "Model-Based Iterative Reconstruction for Synchrotron X-Ray Tomography", Proceedings of IEEE ICASSP 2014
- [4] S. V. Venkatakrisnan, Ercan Cakmak, Philip Bingham, Hassina Billheux, Richard Archibald, "Iterative Image Reconstruction for Neutron Laminography", to appear, Asilomar Conference of Signals, Systems and Computer, Nov. 2017

Bragg edge imaging of solidification process in lead-bismuth eutectic

Daisuke Ito¹, Hiroataka Sato², Yasushi Saito¹, Takenao Shinohara³

¹Research Reactor Institute, Kyoto University; ²Hokkaido University; ³Japan Atomic Energy Science

Lead-bismuth eutectic (LBE) has been investigated as a candidate for a coolant in fast reactor and accelerator driven system. The LBE has lower melting point (≈ 125 °C) in a comparison with other metals. The solidification process of the LBE is very important to assess a flow channel blockage accident in the LBE-cooled reactor. Therefore, the solidification behavior should be well understood for a development of such reactor. Although LBE solidification has been studied by some researchers [1], the effect of the crystal structure on the solidification process has not been clarified so far. Thus, in this study, the characteristics of the LBE solidification or re-crystallization were studied by Bragg edge transmission imaging at BL22 in J-PARC. Two imaging experiments were carried out. One was an imaging of LBE solid samples which were solidified with different cooling speed, and another was a visualization of the transient solidification process of the LBE. The typical results of solid sample imaging are shown in Fig.1. The LBE was encapsulated in an aluminum container and the sample thickness is 10 mm. A GEM detector was used and its spatial resolution is 0.8 mm. Neutron transmission spectra at each pixel can be obtained by using this detector [2]. Fig. 1 represents the wavelength resolved images at a wavelength of 5.4 Å which indicates Bragg edge of β -phase in the LBE. It is found that the crystal structure is changed by the cooling process. Furthermore, the crystal grain size and its number density can be roughly estimated from the image. Such information will be helpful for understanding the re-crystallization of the LBE.

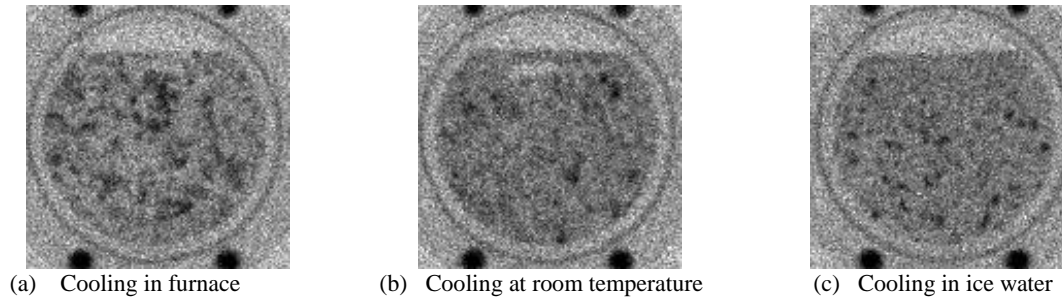

Fig.1 Bragg edge images of solid LBE samples with difference cooling process

Reference

- [1] Glasbrenner, et al., Expansion of solidified lead bismuth eutectic, Journal of Nuclear Materials, 343 (2005) 341-348.
- [2] Ito, et al., Visualization of solidification process in lead-bismuth eutectic, ITMNR-8, Beijing, China (2016)

Dynamic microstructural evolution of additively manufactured Inconel 718 parts using Bragg-edge imaging radiography and neutron diffraction

Gian Song¹, H.Z. Bilheux¹, J.-C. Bilheux¹, J. Lin¹, Q. Xie¹, K. An¹, A. D. Stoica¹, L. Santodonato¹, R. R. Dehoff², M. M. Kirka², S. Gorti³, B. Radhakrishnan³, A. Tremsin⁴

¹*Neutron Sciences Directorate, Oak Ridge National Laboratory*

²*Physical Sciences Directorate, Oak Ridge National Laboratory*

³*Computing & Computational Sciences Directorate, Oak Ridge National Laboratory*

⁴*Experimental Astrophysics Group, Space Sciences Laboratory, University of California, Berkeley*

There have been numerous efforts to adopt additive manufacturing (AM) technique into a variety of metal materials fields because of the excellent design flexibility and microstructure control capability. However, AM is still an immature technique compared to conventional manufacturing techniques due to a lack of in-depth understanding of the link between AM processing and microstructure. Therefore, rigorous characterization methods and predictive modeling of the microstructure of AM materials are needed to understand AM materials properties, lifetime performance and failure mechanisms. Wavelength-dependent neutron radiography, the so-called Bragg edge radiography, has been utilized to study grain orientation, averaged residual stress, and phase distribution in a handful of conventionally built AM materials. Recently, Bragg-edge neutron radiography has become available at facilities with high neutron flux, time resolution and advances detectors, such as the Spallation Neutron Source (SNS) at the Oak Ridge National Laboratory. In the present study, we apply the Bragg-edge radiography and theoretical modelling to characterize AM Inconel 718 samples with a strong crystallographic texture (columnar grain). In-situ heating Bragg-edge neutron experiments were conducted at the SNS SNAP beamline to capture the thermally-induced dynamic evolution of the microstructure. Also, quantitative analysis of the Bragg-edge spectra was carried out using a theoretical fitting, allowing the understanding of the evolution of the angular distribution of the preferred grain orientation. Moreover, comparative texture measurements using neutron diffraction at the SNS VULCAN engineering diffractometer validated the crystallographic information obtained from Bragg edge imaging.

Acknowledgments

This research is sponsored by the Laboratory Directed Research and Development Program of ORNL, managed by UT-Battelle LLC, for DOE. Resources at the High Flux Isotope Reactor and Spallation Neutron Source, U.S. DOE Office of Science User Facilities operated by ORNL, were used in this research. Research at Manufacturing

Demonstration Facility (MDF) was sponsored by the U.S. Department of Energy, Office of Energy Efficiency and Renewable Energy, Advanced Manufacturing Office, under contract DE-AC05-00OR22725 with UT-Battelle, LLC. The team thanks Drs. S. Gorti and B. Radhakrishnan for mentoring the team in modeling, J. Molaison, M. Frost, R. Mills and H. Skorpenske for setting up the detector and furnace at the SNS beamlines. The authors also thank Dr. Antonio Moreira Dos Santos for his help at the SNAP beamline.

Coupling between creep and redox behaviour in half-SOC cells observed in-situ by Bragg edge neutron imaging.

M. Makowska^{1, 2}, M. Strobl³, H.L. Frandsen⁴, S. Schmidt⁴, M.-E. Lacatusu⁴, M. Morgano³, T. Kai⁵, T. Shinohara⁵, A. S. Tremsin⁶, L. Theil Kuhn⁴

¹Forschungs-Neutronenquelle Heinz Maier-Leibnitz (FRM II), Germany; ² Bayreuth University (BGI), Germany; ³ Paul Scherrer Institut, CH-5232 Villigen PSI, Switzerland; ⁴ DTU Energy, Technical University of Denmark, DK-4000 Roskilde, Denmark ⁵ JPARC Center, Japan Atomic Energy Agency, Tokai, Ibaraki 319-1195, Japan ⁶ Space Sciences Laboratory, University of California, Berkeley, CA 94720, USA

One of the most common materials used for solid oxide cell (SOC) fuel electrodes is nickel-yttria stabilized zirconia (Ni-YSZ) cermet. Under operating conditions SOC are exposed to elevated temperatures (750°C-850°C) and to reducing atmosphere, moreover under certain circumstances, also to oxidizing conditions. Thus, redox stability is one of the crucial requirements for this material. Mismatch of the thermal expansion coefficients (TEC) of anode, cathode and electrolyte causes significant stress field in the cells during thermal cycling, which may lead to failures and degradation of the cell.

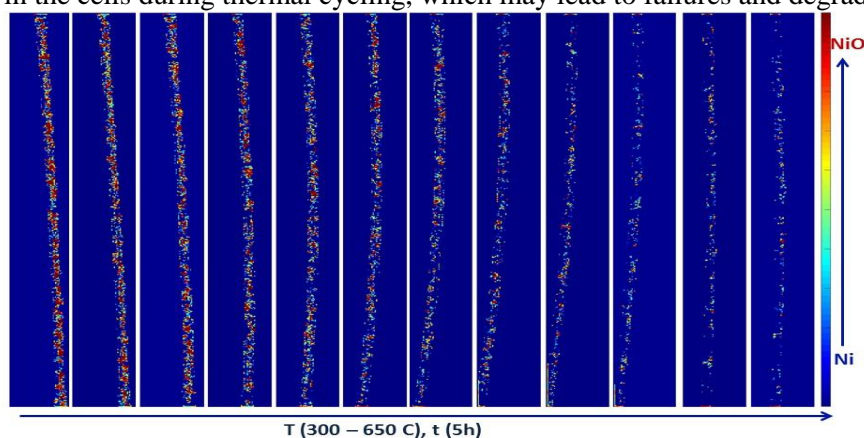

Fig. 1 Phase transition and deformation in SOC half-cells during reduction. The scale on the color bar corresponds to the content of NiO phase.

The results of the studies performed at the pulsed neutron source J-PARC at the RADEN instrument will be presented. Several samples - so-called SOC half-cells (composed of only 2 layers: a fuel electrode (NiO/Ni-YSZ) and an electrolyte (YSZ)) were investigated. Samples were exposed to elevated temperatures as well as reducing and oxidizing atmospheres. During redox cycling phase transition (NiO - Ni) and deformation of the samples caused by mismatch of the TEC of the layers were observed in situ by means of time of flight Bragg edge imaging (Fig. 1). The data was recorded with a Multi Channel Plate (MCP) detector with 55 μm pixel size.

The studied materials are very brittle ceramics and such significant deformation (Fig.1) under stable conditions would lead to cracking and breaking of layers. However, if bending stress is applied together with conditions causing chemical reactions in the Ni/NiO phase (either reduction or oxidation), so-called accelerated creep is observed¹, which helps to release the strains and thus allows for such tremendous deformation of the layers.

References:

1. Makowska, M. G. *et al.* Coupling between creep and redox behavior in nickel - yttria stabilized zirconia observed in-situ by monochromatic neutron imaging. *J. Power Sources* **340**, 167–175 (2017).

Observation of lithium-ion battery by using the Bragg-edge imaging technique

T. Kai¹, Y. Su¹, K. Hiroi¹, T. Shinohara¹, K. Oikawa¹, H. Hayashida², J. D. Parker², Y. Matsumoto², M. Segawa¹, T. Nakatani¹, Y. Kiyonagi³

¹Japan Atomic Energy Agency, Tokai-mura Naka-gun, Ibaraki 319-1195, Japan

²Comprehensive Research Organization for Science and Society, Tokai, Ibaraki 319-1106, Japan

³Nagoya University, Nagoya, Aichi 464-8603, Japan

Lithium ion batteries are expected to be used in an enormous variety of products in the age to come. Extensive studies have been carried out to improve the performance of lithium ion batteries by many industrial and academic researchers. Neutron imaging can be a powerful technique to investigate lithium ion batteries under operating conditions. In this presentation, an observation of lithium ion batteries by using a Bragg-edge imaging technique with short-pulse neutrons will be introduced.

The lattice spacing of a graphite anode increases with the state-of-charge (SOC) due to the intercalation of lithium ions, and it has been reported that a spatial distribution in the lattice spacing was visualized by the neutron Bragg-edge imaging technique [1]. At RADEN of J-PARC MLF, two dimensional neutron spectra were measured for commercially available lithium ion batteries to examine possible effects of casing structure on the distribution of the lattice spacing. The outer dimensions of the batteries were 14 mm in thickness, 140 mm in width and 80 mm in height, and the lithium ion batteries were constrained by containing in two types of thick aluminum casings of different structures, referred to as Type-A and Type-B. The measurements were performed for 20 minutes after changing SOC by charging or discharging. The proton beam power was 150 kW or 200 kW, and the neutron beam collimation was selected to provide the highest intensity.

The Bragg-edge of graphite (002) was found to change between 6.7 and 7.0 Å over the full range of SOC, while the neutron transmission rates at wavelengths longer than 7.0 Å remained unchanged. Figure 1 shows the spatial distributions of transmitted neutrons between 6.7 and 7.0 Å relative to those between 7.3 and 8.2 Å for lithium ion batteries with different aluminum casings. The lattice spacing turned out to be inhomogeneous when increasing SOC from 10% to 40% in the Type-A case. A localization of lithium ion intercalations in the graphite anode due to the difference of the casing structure was successfully visualized by the Bragg-edge imaging technique.

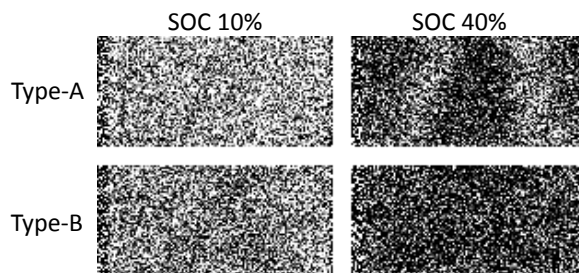

Fig. 1 Spatial distribution of SOC in lithium ion batteries with different casing

Acknowledgement

This work was supported by the ‘Photon and Quantum Basic Research Coordinated Development Program’ from the Ministry of Education, Culture, Sports, Science and Technology (MEXT).

Reference

[1] T. Kamiyama, et al., to be published in Proc. of ITMNR-8, “Structural change of carbon anode in a lithium-ion battery product associated with charging process by neutron transmission Bragg-edge imaging”.

Progress in Neutron Imaging (during/by the NEUWAVE workshop series)

Eberhard H. Lehmann

Neutron Imaging & Activation Group, Laboratory for Neutron Scattering & Imaging Paul Scherrer Institut, CH-5232 Villigen PSI, Switzerland

The first NEUWAVE workshop was initiated by B. Schillinger and the author in 2008 and held at FRM-2 in Garching/Munich. Driven and supported by the European Network NMI-3, experts from all leading centers with interests in new attempts in neutron imaging were invited. Since the major topic “energy selective neutron imaging” was chosen, the upcoming pulsed spallation sources in Japan, USA, Europe came into the focus of the discussions. The number of participants was limited to 40-60 and the focus was towards young scientists, not excluding the more experienced ones.

After eight workshops within the NEUWAVE series until today, a very positive resume can be given. First of all, new and extremely comfortable facilities were completed meanwhile at JPARC (RADEN) and ISIS-TS2 (IMAT). Further projects are on the way at ESS (ODIN) and SNS (VENUS) with very promising performance features. At the IBR-2 pulsed reactor source an imaging beamline was installed, currently for common white beam applications, but with the potential for TOF imaging in the future.

From the scientific point of view, a clear link to neutron scattering methods was established. The understanding and description of the diffraction at lattice planes of crystalline structural materials by means of energy selective techniques was initiated and results already given during the first NEUWAVE meetings. On top of these Bragg scattering attempts, first trial were done to measure and visualize stress and strain in macroscopic samples with the advantage of high spatial resolution. Analysis tools and a data base for Bragg scattering were established and used for the evaluation of the experimental data [1, 2].

At the same time, neutron grating interferometry (nGI) techniques were developed and devices installed at different places. With the help of nGI it was possible to visualize the magnetic domain structures in bulk samples and to quantify the particle size distribution in solutions by using the “dark field” signal. This approach has correspondence to the SANS and USANS techniques in neutron scattering. Related talks were given at established neutron scattering conferences (ECNS2016, Zaragoza; ACNS2016 Los Angeles, ...). Since NEUWAVE is open for other developments beside the energy selective techniques, progress has been demonstrated for imaging with epithermal and fast neutrons and the studies using polarized neutrons. Magnetic properties and field distributions can be visualized and measured directly. The behavior of superconducting materials has been investigated at very low temperatures in-situ.

One of the key components of sophisticated new studies has been found in the MCP based pixel detector, developed and applied by A. Tremsin in many labs around the globe. Its performance is unique and promising as standard configuration at the new imaging facilities at pulsed sources.

The success of the NEUWAVE workshop series should be continued by the involvement of further partners with promising new techniques, facilities and applications. The direct dialogue among the participants is the most efficient and progressing way of interaction.

Reference:

[1] H. Sato, T. Kamiyama Y. Kiyonagi, , Vol. 52, No. 6 (2011) pp. 1294 to 1302

[2] E.H. Lehmann, S. Peetermans, L. Josic, H. Leber, H. van Swygenhoven, , NIM A, Volume 735, Pages 102-109

Poster Session Presentations, Monday 12 JUN 2017, 8 PM to 11 PM

| Poster # | Presenter | Title |
|----------|-----------------------|---|
| 1 | Andrew Holmgren | Simulations of Neutron Strain Imaging Using Coded Apertures |
| 2 | Ralf Ziesche | Investigation of the Lithiation Process of commercial and lab made Li-Ion Batteries |
| 3 | Robert Nshimirimana | Investigation of laser treated steel using neutron wavelength dependent imaging |
| 4 | Daniel Pooley | Further Development of the 'GP2' Event-mode Imaging Detector |
| 5 | David Jacobson | Centroiding GadOx detector |
| 6 | Yuxuan Zhang | Neutron Resonance Imaging of Uranium in Advanced Nuclear Fuel |
| 7 | Daniel Hussey | Cold Neutron Imaging at NIST |
| 8 | Manuel Morgano | The ODIN guide system at ESS |
| 9 | Aureliano Tartaglione | Update on the design of ASTOR, the cold neutron imaging instrument for the Argentinean RA-10 reactor |
| 10 | Boris Khaykovich | Design of a thermal-neutron microscope for post-irradiation examination of irradiated nuclear fuel |
| 11 | Nicholas Borges | Feasibility of Small Animal Anatomical and Functional Imaging with Neutrons |
| 12 | Stefano Deledda | Upgrading the Neutron Radiography Set-Up at IFE in Kjeller, Norway |
| 13 | Winfried Kockelmann | IMAT: Project Status and Future Plans |
| 14 | Ralf Ziesche | Simulation of flux trapping behaviour in Type II Superconductor using Polarised Neutron Imaging |
| 15 | Ralph Harti | TaPy - An open and hackable tool for neutron grating interferometry |
| 16 | Jake LaManna | NeXT |
| 17 | Aureliano Tartaglione | Absolute determination of low hydrogen concentrations in Zr alloys by wavelength resolved neutron imaging |
| 18 | Sven Vogel | Neutron Radiography with cold, thermal, epi-thermal, and fast neutrons at LANSCE |
| 19 | Kenichi Watanabe | Bragg-edge analysis using energy-resolved neutron tomography |

Simulations of Neutron Strain Imaging Using Coded Apertures

Andrew Holmgren, Matthew Connolly, Edward Garboczi

National Institute of Standards and Technology, 325 Broadway, Boulder CO 80305

Transmission Bragg Edge (TBE) measurements utilize an energy selective beam to image strain fields. Although there has been significant interest in extending TBE to provide tomographic reconstruction of an object's strain field, the problem remains ill-posed, and the required data is not available without significant system modifications. One way to obtain additional information is to measure the scattered beam concurrent with TBE measurements. Coherent neutron scattering is constrained by Bragg's law and consequently contains information about atomic lattices in a material. Coherent scattering from materials with random grain orientations emit a cone of scatter, with cone angle relating to both the lattice spacing and incident wavelength. The current standard for detecting scatter from a volume is to collimate the scatter at the detector such that only a small portion of the overall volume contributes to the detector measurement. We propose a system that uses a coded aperture, rather than collimators, to uniquely determine volume elements. The coded aperture increases the neutron count rate at the detector and reduces scan time. The simulation study shows the ability, using neutron scattering, to detect atomic spacings in a 2D slice of the object, such that either specific slices or the entire 3D volume can be imaged by accumulating the appropriate slices. The current model assumes uniformly random grain distributions to approximate spherically symmetric atomic lattices. Future study will look at anisotropies in atomic spacing to determine 3D strain in objects.

Investigation of the Lithiation Process of commercial and lab made Li-Ion BatteriesR.

Ziesche^{1,2}, T. Minniti², N. Kardjilov³, W. Kockelmann², J. Weaving¹, R. Woracek⁴ and P. Shearing²

¹Department of Chemical Engineering, University College London, Torrington Place, London WC1E 7JE, UK
²STFC, Rutherford Appleton Laboratory, ISIS Facility, Chilton, OX11 0QX, UK ³Helmholtz Zentrum für Materialien und Energie, FG-GTOMO, 14109 Berlin, Germany ⁴European Spallation Source ESS ERIC, P.O. Box176, SE-22100 Lund, Sweden

Lithium batteries have been one of the transformative technologies of the 20th century and have enabled a revolution in consumer electronics – in the 21st century they promise to enable further technological progress with applications as diverse as automotive power trains, space propulsion and medical implants. These applications demand high capacity and high charge/discharge rates in a wide range of conditions including high temperatures and the ability to withstand severe mechanical, thermal and electrical abuse. To enhance the performance of Li-Ion batteries it is necessary to obtain a detailed understanding of the interior chemical operations at different states of charge, and life times as well as under conditions of extreme operation. X-ray imaging techniques has been widely used to characterize battery materials and devices, nevertheless owing to the lower temporal and spatial resolution of neutron imaging, these techniques have been less widely adopted. However, neutrons offer a great way to provide local information of the charging/discharging process by the high attenuation coefficient (μ) of the Li-ions compared with the low absorption coefficient of Cu and Al which are used as current collectors [1]. In our study we tomographed the Lithium intercalation of a commercial primary CR-2 Li MnO₂ battery from DURACELL (fig. 1a and fig. 1b) [2]. An increase in neutron absorption in the MnO₂ anode, while discharging, enables us to figure out where high potential of improvements in case of 'dead' areas of lithiation are. Furthermore, we explored the d-spacing of Lithium intercalation of self-made and commercial graphite anode batteries with Bragg-edge imaging. In this first study, we compared measured data with calculated ones (fig. 1c) [3] [4].

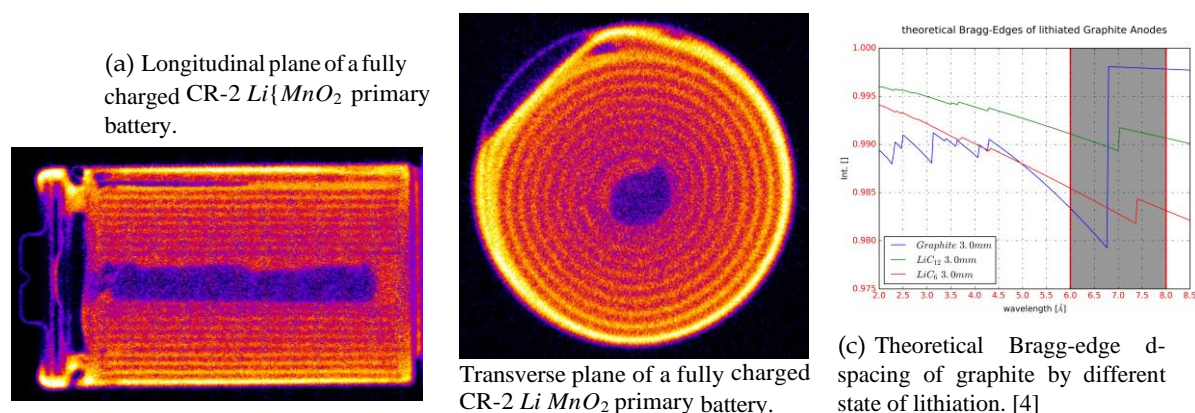

Figure 1: Slices of a tomography of a charged commercial primary CR-2 Li MnO₂ battery from DURACELL, measured on the IMAT beamline @ ISIS facility, and theoretical Bragg-edge d-spacing for lithated graphite.

References

- [1] Siegel, J. B., et al, Neutron Imaging of Lithium Concentration in LFP Pouch Cell Battery Journal of The Electrochemical Society, 2011, 158, A523-A529
- [2] Finegan, D. P., et al, Quantifying Bulk Electrode Strain and Material Displacement within Lithium Batteries via High-Speed Operando Tomography and Digital Volume Correlation Advanced Science, 2016, 3, 1500332-n/a
- [3] Woracek, R., et al, The test beamline of the European Spallation Source – Instrumentation development and wavelength frame multiplication Nuclear Instruments and Methods in Physics Research Section A: 2016, 839, 102 - 116
- [4] Boin, M., nxs: a program library for neutron cross section calculations Journal of Applied Crystallography, 2012, 45, 603-607

Investigation of laser treated steel using neutron wavelength dependent imaging

Robert Nshimirimana¹, Winfried Kockelmann², Triestino Minniti², Andrew Venter¹, Anton Tremsin³

¹ Research and Development Division, South African Nuclear Energy Corporation (Necsa), Brits Magisterial District, South Africa

² STFC-ISIS, Rutherford Appleton Laboratory, Harwell, OX11 0qx, UK

³ Space Science Laboratory, University of California at Berkeley, Berkeley, CA 94720, USA

Laser treatment of metal surfaces is amongst others done to enhance aesthetic and physical properties. These include the attainment of cosmetic changes such as coloration [1], or improved performance such as corrosion resistance [2], hardness [3, 4] and subsequently fatigue life [5]. Although laser treatment is valuable, the process can introduce residual stresses on the surface of the metal. One such process is laser transformation hardening (LTH). The capability of LTH was investigated using neutron wavelength dependent imaging at the Imaging and Material Science & Engineering (IMAT) facility in the UK. The investigation was conducted on a 30 x 20 x 20 mm³ ferrous 26NiCrMoV14-5 steel treated with an Nd:YAG laser. A 28 x 28 mm² MCP detector [6] area with a spatial resolution of 55 μm was used in data acquisition. A differential depth-resolved strain map (Figure 1) calculated from (110) Bragg edge at the wavelength of 4.056 \AA is presented.

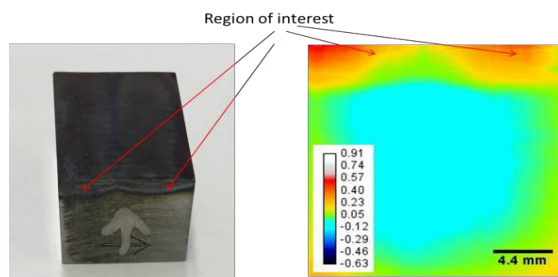

Figure 1: Differential transmission strain map in the surface treated steel sample. The map was obtained using neutron transmission wavelength dependent imaging.

References:

- [1]. Del Pin, A.P.; Fernandez-Pradas, J.M.; Serra, P. and Morenza, J.L. 2004. Coloring of titanium through laser oxidation: Comparative study with anodizing. *Surface and Coating Technology* 187(1): 106-112.
- [2]. Kim, J.; Ha, T.; Park, J. and Kim, H. 2016. Effect of Laser Surface Treatment on the Corrosion Behavior of FeCrAl-Coated TZM Alloy. *Metals* 6(1),29:1-8.
- [3]. Fernande de Lima, M.S.; Goia, F.A; Riva, R. and Santo, A.M.E. 2007. Laser surface remelting and hardening of an automotive shaft using a high-power fiber laser. *Material Research* 10(4):461-467.
- [4]. Brandal, G. and Yao, Y.L.2016. Material Influence on Mitigation of Stress Corrosion Cracking Via Laser Shock Peening. *J. Manuf. Sci. Eng* 139(1), 011002; doi: 10.1115/1.4034283.
- [5]. Lavenda, C.A; Hong, S.; Smith, M.T.; Johnson, R.T. and Lahrman, D. 2008. The effect of laser shock peening on the life and failure mode of a cold pilger die. *Journal of materials processing technology* 204:486-491.
- [6]. Tremsin, A.S.; Vallerga, J.V.; McPhate, J.B. and Siegmund O.H.W. 2015. Optimization of high count rate event counting detector with Microchannel Plates and quad Timepix readout. *Nucl, Instr. Meth. A* 787:20-25.

Further Development of the ‘GP2’ Event-mode Imaging Detector

D. E. Pooley¹, J. W. L. Lee², C. Moreton-Smith¹, M. Brouard⁴, J. J. John³, W. Kockelmann¹, N. J. Rhodes¹, E. M. Schooneveld¹, F. A. Akeroyd¹, I. Sedgwick¹, R. Turchetta¹, C. Vallance²

¹STFC, Rutherford Appleton Laboratory, Harwell Oxford, Didcot, OX11 0QX, UK, (e-mail author daniel.pooley@stfc.ac.uk).; ²Department of Chemistry, Chemistry Research Laboratory, 12 Mansfield Rd, University of Oxford, Oxford, UK; ³Department of Physics, Denys Wilkinson Building, Keble Rd, University of Oxford, Oxford, UK; ⁴Department of Chemistry, Physical and Theoretical Chemistry Laboratory, South Parks Road, University of Oxford, Oxford, UK

The specification and development of the GP2 detector has previously been reported at Neuwave. Previous results focused on the development of the hardware, establishing important parameters such as neutron detection efficiency (7.5% at 2.5Å), gamma sensitivity (1.5E-3), and spatial resolution (MTF@10% =71µm) for a 4µm thick natural gadolinium neutron converter film. Important tests for memory effects (image burn-in), radiation hardness and stability were emphasized alongside the novel features of the detector. Examples include the small form factor of the detector assembly (the complete detector measuring about 15x15x15 cm³) and the potential to place the detector close to the sample due to there being no requirement for vacuum or optical isolation.

At this meeting we will report on the software requirements and strategy to integrate the detector into the ISIS instrument control and data infrastructure. Information will be provided on the control and readout of the camera from the IBEX interface and the options for data readout and archiving. The strategy for full integration into the IMAT user cycle will be presented. Emphasis will be placed on the handling of event mode data, where each detected neutron is given a unique (x, y, time, frame) identifier. This is illustrated in figure 1 below. Current hardware developments will also be shown, which focus on USB3 readout and compacting the camera assembly further.

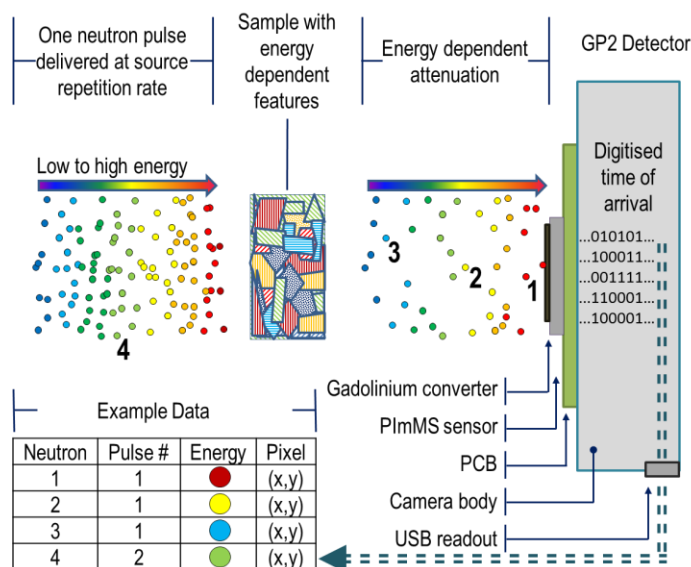

Figure 1. Sketch illustrating the energy dependent beam attenuation, as measured in a typical experiment. The GP2 detector records every neutron’s arrival time, giving the energy of that neutron and its (x,y) position. Four neutrons, labelled 1-4, from two separate neutron pulses are labelled to illustrate this point.

Neutron imaging detector with 2 μm spatial resolution based on event reconstruction of neutron capture in gadolinium oxysulfide scintillators

David L. Jacobson¹, Jacob M. LaManna¹, Elias Baltic¹, Daniel S. Hussey¹

¹Physical Measurement Laboratory, National Institute of Standards and Technology, 100 Bureau Dr., MS 8461, Gaithersburg, MD 20899, USA

We report on efforts to improve the achievable spatial resolution in neutron imaging by centroiding the scintillation light from gadolinium oxysulfide scintillators.[1] The current state-of-the-art neutron imaging spatial resolution is about 10 μm , and many applications of neutron imaging would benefit from at least an order of magnitude improvement in the spatial resolution. The detector scheme that we have developed magnifies the scintillation light from a gadolinium oxysulfide scintillator, calculates the center of mass of the scintillation event, resulting in an event-based imaging detector with spatial resolution of about 2 μm .

References:

[1] D.S. Hussey, J.M. LaManna, E. Baltic, D.L. Jacobson, “Neutron imaging detector with 2 μm spatial resolution based on event reconstruction of neutron capture in gadolinium oxysulfide scintillators”, accepted, Nuclear Instruments and Methods, A (2017).

Neutron Resonance Imaging of Uranium in Advanced Nuclear Fuel

Yuxuan Zhang,^a Hassina Z. Bilheux,^b Jared A. Johnson,^a Kristian G. Myhre,^a Jean C. Bilheux,^c Andrew J. Miskowicz,^a Rodney D. Hunt,^a and Brianne J. Heisinger^d

^a Nuclear Security and Isotope Technology Division, Oak Ridge National Laboratory, Oak Ridge, TN 37831, USA; ^b Chemical and Engineering Materials Division, Oak Ridge National Laboratory, Oak Ridge, TN 37831, USA; ^c Neutron Data Analysis and Visualization Division, Oak Ridge National Laboratory, Oak Ridge, TN 37831, USA; ^d The Bredesen Center for Interdisciplinary Research and Graduate Education, University of Tennessee, Knoxville, TN 37996, USA

Proof-of-principle experiments were carried out at the Spallation Neutron Source (SNS), at Oak Ridge National Laboratory (ORNL), to evaluate the feasibility of mapping uranium isotopes inside advanced nuclear fuel material using neutron resonance imaging. The setup consisted of a micro-channel plate (MCP) detector installed at the SNS Spallation Neutrons and Pressure Diffractometer (SNAP) BL-3 beamline. The L/D ratio was difficult to assess due to the transparency of the slits used at SNAP. The resolution was measured to be $\sim 450 \mu\text{m}$ with the Paul Scherrer Institute (PSI) gadolinium mask. Calibration of the source- to-detector distance was measured by using a tantalum foil of known thickness.

Figures (a) and (b) are plots of the different resonance features of U-238 and U-235 from JANIS, a nuclear database. Figures (c) and (d) are the measured data of U-238 as a function of energy and wavelength, respectively. In this preliminary experiment, U-238 resonance peaks can be clearly observed. Future experiments will focus on measuring U-235 resonance peaks with both U-238 and U-235 present in the fuel material.

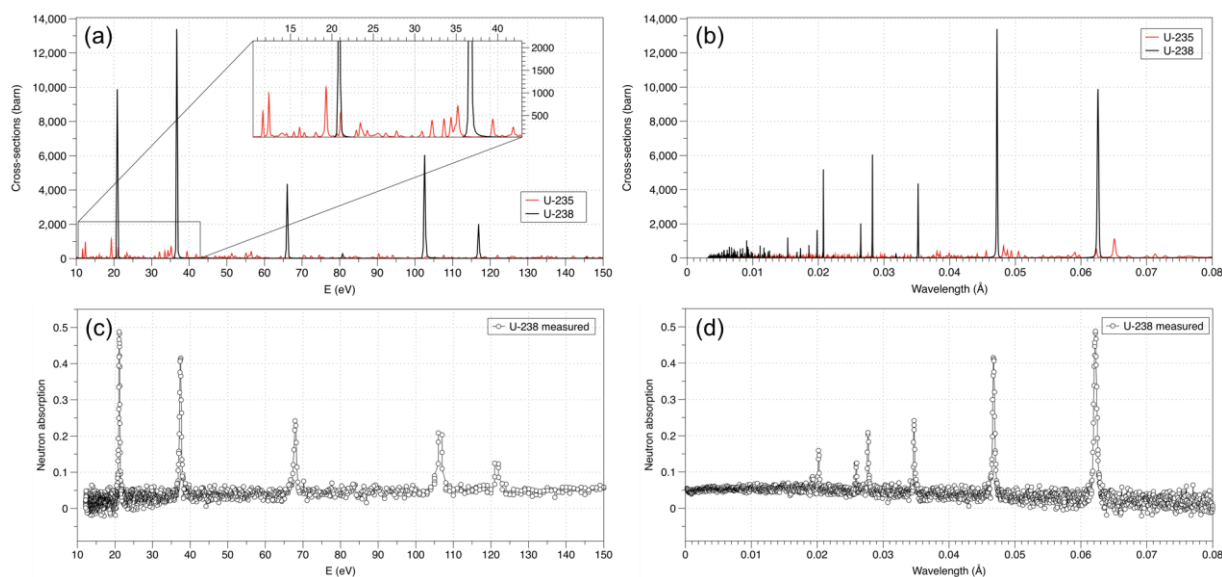

Cold Neutron Imaging at NIST

Daniel Hussey, Jake LaManna, Eli Baltic, David Jacobson, Muhammad Arif

National Institute of Standards and Technology, 100 Bureau Dr. MS 8461, Gaithersburg, MD 20899 USA

A cold neutron imaging instrument was installed at the NIST Center for Neutron Research in August 2015. The ultimate function of the instrument will be to house the neutron microscope based on Wolter optics to enable high speed imaging at high spatial resolution. While these optics are being developed, the instrument is being employed in a variety of method development projects, including a novel neutron interferometer based on the formation of a moiré pattern in the far field and Bragg edge imaging.

The ODIN guide system at ESS

M. Morgano¹, M. Lerche², E. Lehmann¹, M. Strobl¹

¹*Neutron Imaging and Activation Group, Laboratory for Neutron Scattering and Imaging, PSI, Villigen (Switzerland)*

²*FRMII reactor, Technische Universität München, Munich (Germany)*

In this talk I will present the neutron delivery system of the ODIN beamline, the neutron imaging instrument that is planned to start operations in 2021 at the European Spallation Source (ESS), now in construction in Lund, Sweden.

ESS will be a long-pulse source and to take full advantage of the flexibility this option offers, ODIN will need to be a relatively long imaging instrument compared to standard imaging beamline.

The chosen length of the instrument (60m) requires the use of neutron guides in order to efficiently a wide wavelength band, and the requirements imposed by the need to avoid inhomogenities in the intensity and spectral distribution across a wide field of view require additional care in the assessment of the resulting performances.

The bi-spectral nature of the beam extraction and the complicated geometry of the planned “butterfly” moderator, together with the limited room in the vicinity of the target blockhouse dictated by the relatively small angular separation of neighboring beamlines, complete the picture of the complexity of the system.

In this presentation, I will describe the final agreed-upon design of the neutron guide system, its performances and the resulting calculated intensity.

I will also outline the procedure that was used to optimize the m-coating of the entire guide system, thus minimizing the cost.

The guide system thus calculated will be then engineered and built in the next few years, to allow for a timely start of the commissioning of the instrument in 2020.

Update on the design of ASTOR, the cold neutron imaging instrument for the Argentinean RA-10 reactor

Aureliano Tartaglione^{1,2}, Matías Lobo Poblet², Federico Bertalot², Santiago Bazzana², Luis Romero², Salvador Ortiz², Karina Pierpauli², Alberto Filevich² & Javier Santisteban^{1,2}

¹Argentinean Council of Science and Technology (CONICET), Argentina

²Argentinean Atomic Energy Commission (CNEA), Argentina

Argentinean Laboratory of Neutron Beams (LAHN)

Centro Atómico Constituyentes - Av. General Paz 1499

(1650) San Martín - Buenos Aires - Argentina

The new multipurpose 30 MW research reactor RA-10 is under construction in Ezeiza, 35 km southwest from Buenos Aires, Argentina, with start operation planned for middle 2020. The new reactor will have a cold neutron source with liquid deuterium as neutron moderator (23 K), and eight state-of-the-art neutron beams, four cold and four thermal. Neutron instruments will be built and operated by the Argentinean Laboratory of Neutron Beams (LAHN). Two instruments have been funded for the first stage, a neutron imaging instrument called ASTOR (**A**dvanced **S**ystem of **T**Omography and **R**adiography) and a strain scanner neutron diffractometer (ANDES). After a review from an international scientific and technical advisory panel (Buenos Aires, March 2017), ASTOR conceptual design is now finished. It is designed to have several options of collimation of the beam, allowing users to choose between high flux/low resolution and low flux/high resolution options, as global operational modes. Also, there will be the possibility of setting the sample and the detector in any position between 6 m and 11 m from the biological shielding. ASTOR will have a beam adjusted primary collimator, integrated with the rotating primary shutter, inside the reactor biological shielding. This component will have also an aperture to define the lower collimation option (maximum neutron flux). Once outside the biological shielding, a remote controlled device for additional apertures and beam adjusted secondary collimators will be installed. The goal is to offer high flexibility, through operational options that provide a maximum field of view of 27 cm x 27 cm or maximum neutron flux of $\sim 3 \cdot 10^8$ n/cm²s or to reach spatial standard resolution of around 25 μ m.

The design of ASTOR considers dedicated space to place several devices to optimize the beam for the required neutron imaging technique. Astor will have at least three coarse neutron filters in a rotating wheel: beryllium, graphite and cadmium. In addition ASTOR will provide users with the possibility of velocity selection in the estimated (classical) range 3Å to 6Å with lambda resolutions of $\sim 10\%$ (velocity selector) or 1-4% (double crystal monochromator), with an expected maximum field of view of 10cm x 10cm and a standard spatial resolution of $\sim 100\mu$ m.

Design of a thermal-neutron microscope for post-irradiation examination of irradiated nuclear fuel

B. Khaykovich¹, M. Abir², D. K. Rai¹, H. Wu³

¹Nuclear Reactor Laboratory, Massachusetts Institute of Technology, Cambridge, MA, USA

²Materials and Fuel Complex, Idaho National Laboratory, Idaho Falls, ID 83415, USA

³Department of Engineering Physics, Tsinghua University, Beijing, 100084, China

Nuclear fuel assemblies in an operating nuclear power reactor experience extreme environmental conditions, such as exceptionally high neutron and gamma flux and sometimes temperatures approaching 1000 °C. Novel accident-tolerant fuels would withstand even more challenging situations, such as sudden increases in temperature, without catastrophic release to the environment. These fuels are extensively tested in dedicated research reactors. One of the first post-irradiation examinations (PIE) methods employed after samples are removed from the test reactor is neutron radiography, which checks for the integrity of fuel elements and cladding. The difficulties of handling these samples often demand a dedicated reactor for the radiography, adjacent to a hot cell, such as a 250 kW NRAD reactor at Idaho National Lab. Since the radiography samples must be placed in a close proximity of the detector, strong gamma radiation from the fuel would damage modern electronic detectors in seconds. Therefore, fuel radiography employs the non-digital indirect foil film method, where Dysprosium and Indium foils serve as neutron converters. Handling of foils adds great expense in time and resources. In this paper, we propose a solution, which would permit the use of digital detectors and enable tomography of highly radioactive samples at high resolution. The solution is based on the observation that in microscopes, in contrast to pinhole cameras, samples are separated from detectors by image-forming optics. Our design is of coaxial confocal axisymmetric mirrors, or Wolter mirrors. We demonstrate a design of mirrors for thermal neutrons, enabling the separation between a sample and a detector by more than 10 m.

The mirrors will consist of symmetric confocal pairs of hyperboloid and paraboloid sections, as shown in the Figure. The impact of this design goes beyond the application to nuclear fuel. Such a neutron microscope could revolutionize thermal-neutron radiography at small reactors by increasing the available flux and resolution by an order of magnitude or more.

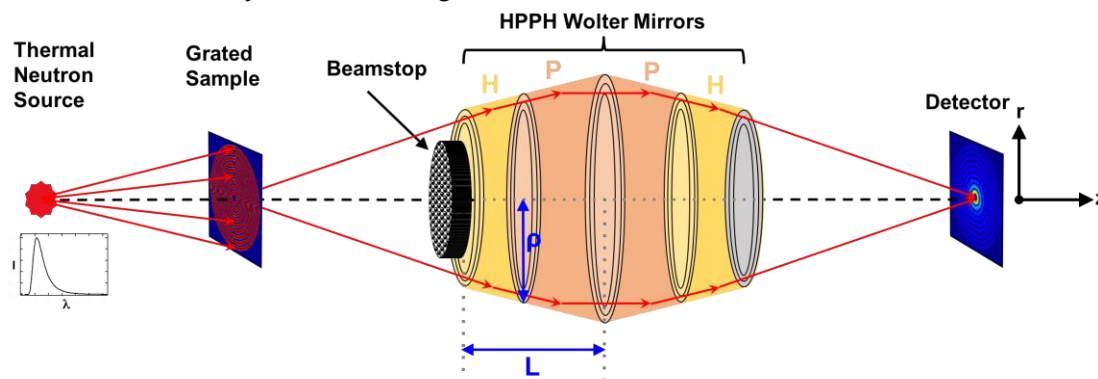

Feasibility of Small Animal Anatomical and Functional Imaging with Neutrons

Nicholas Borges¹, Monika Patial¹, Shane Waterman¹, Andrew Karellas², David Medich¹

¹*Department of Physics, Worcester Polytechnic Institute, Worcester, Ma 01609*

²*University of Massachusetts Medical School, Worcester, MA 01655*

Hydrogenous samples analyzed using neutron radiography/tomography suffer from reduced image contrast and resolution due to the high neutron-scatter cross section with hydrogen. As such, neutrons presently are not used for thick-tissue or in-vivo imaging. To that end, we present a method to enable high-quality neutron imaging of biological objects, such as a mouse, through proper scatter rejection and incorporation of a gadolinium-based contrast agent. Functional neutron imaging particularly could be important because it could achieve a spatial resolution orders of magnitude better than what presently can be achieved with current imaging technologies such as nuclear medicine (PET, SPECT) and fMRI.

For this study, Monte Carlo simulations were performed with thermal (0.025eV) neutrons impinging on a 3 cm thick phantom using the MCNP5/6 simulations software. The goals of this study were to determine the extent that scattered neutrons degrade image contrast, the contrast between of various tissue with perfect scatter rejection, and the collimation required for neutron scatter rejection in hydrogenous materials.

Results demonstrate that with proper neutron-scatter rejection, a neutron fluence of 5×10^6 n/cm² will provide a signal to noise ratios of at least one ($S/N \geq 1$) when attempting to image various 300 μ m thick tissues placed in a 3 cm thick phantom. Neutron scatter contributions lowered by two to three orders of magnitude, a neutron collimator array with an L/D of at least 25 can achieve appropriate scatter rejection to enable neutron radiography of biological and hydrogenous systems.

Upgrading the Neutron Radiography Set-Up at IFE in Kjeller, Norway

Stefano Deledda, Carolin Prabhu, Geir Helgesen, Håkon K. Jenssen

Institute for Energy Technology, PO Box 40, NO-2027 Kjeller, Norway

The JEEP II research reactor (2 MW thermal power) at the Institute for Energy Technology (IFE) in Kjeller (Norway) is presently the only neutron source in the Nordic Countries. A national infrastructure project, funded by Research Council of Norway, to upgrade the neutron scattering facilities, *NcNeutron*, is currently running (2016-2020). *NcNeutron* aims at establishing a neutron research and technology exchange center and being a Norwegian and regional home-laboratory in neutron-based science.

The upgrade of the facilities includes the reconstruction and modernization of the neutron radiography instrumentation which was built in the mid-1970s. The current setup is based on a traditional Dy-foil technique with a relatively high spatial resolution (40-50 μm), but with a low maximum number of recorded images per day and with a man-hour intensive image processing. The facility is presently dedicated to the analysis of post-irradiation examination data from safety and integrity tests of nuclear fuels performed within reactor safety research projects.

The neutron radiography upgrade, currently in the design phase, consists of three main tasks: (i) beam optimization (new sapphire filter, new aperture, and new in-pile collimator); (ii) modification of the current radiography cell, implementing different configurations for the analysis of radioactive and non-radioactive samples; (iii) installation of new sample stage and new digital neutron imaging detector.

The new neutron imaging instrument (NIMRA) is being designed to have an L/D ratio of up to 300 and a FOV of $15 \times 15 \text{ cm}^2$. It will be intended for studying energy materials (e.g. hydrogen storage systems, Li-ion batteries, heat storage units) as well as flow in porous media (e.g. clays, concrete). However, applications within other material classes and systems will be actively pursued.

IMAT: Project Status and Future Plans

W. Kockelmann¹, T. Minniti¹, G. Burca¹, J.F. Kelleher¹, S. Kabra¹, D. Tasev¹, D.E. Pooley¹, E.M. Schooneveld¹, J. Sykora¹, N.J. Rhodes¹, F. Aliotta², R. Ponterio², G. Salvato², C. Vasi², K. Watanabe³, A.S. Tremsin⁴, W. Halcrow¹, J.B. Nightingale¹

¹STFC-Rutherford Appleton Laboratory, ISIS Facility, Chilton, OX11 0QX, UK; ²CNR-IPCF, I-98158 Messina, Italy; ³Nuclear Measurement Engineering Group, Nagoya University, Nagoya, 464-8603 Japan; ⁴Space Sciences Laboratory, University of California at Berkeley, Berkeley, CA 94720, USA

IMAT has recently been taken into operation on TS-2 at ISIS as part of the ‘Phase-2 project’ [1]. The instrument provides white-beam and energy-dispersive radiography and tomography. IMAT has completed the first round of commissioning where key instrument parameters have been determined [2]. The installation of various components was completed, such as the large sample positioning system and a robot arm to carry and exchange imaging cameras. Issues with some of the components are reported, for example the T0 chopper design and the biological shielding around the sample area, which is being reinforced.

Current activities on IMAT are: development of a TOF camera based on a ‘PImMS’ CMOS sensor; development of TOF data analysis tools; preparations for the operation of loading rigs. There have been substantial in-kind contributions from the Italian PANAREA project, notably a CCD camera box including camera modules from CNR Messina.

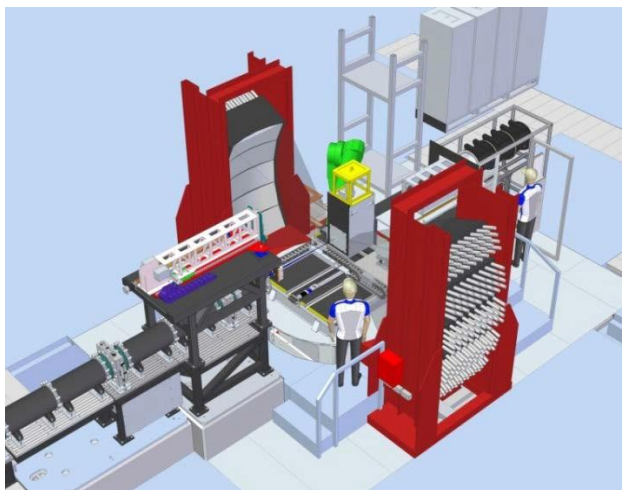

Figure 1: Design of the IMAT sample area, showing a camera box on a robotic arm and 90-degree diffraction detectors.

After a period of further commissioning and operation with ‘friendly-users’, there will be a first call for IMAT proposals in October 2017 for using the imaging options only. In the near future the imaging setup will be complemented with diffraction detectors based on ZnS/LiF scintillators and wavelength shifting fibre, for spatially-resolved phase, strain and texture analyses of regions of interest (Figure 1).

References:

- [1] W. Kockelmann et al., Physics Procedia 69 (2015) 71.
- [2] T. Minniti et al., this workshop (2017)

Simulation of flux trapping behavior in type II superconductor using polarized neutron imaging

R. Ziesche^{1,2,3}, I. Dhiman^{3,4}, J. Nicol³, L. Riik³ and W. Treimer^{3,5}

¹Department of Chemical Engineering, University College London, Torrington Place, London WC1E 7JE, UK; ²STFC, Rutherford Appleton Laboratory, ISIS Facility, Chilton, OX11 0QX, UK; ³Helmholtz Zentrum für Materialien und Energie, FG-GTOMO, 14109 Berlin, Germany; ⁴Chemical and Engineering Materials Division, Oak Ridge National Laboratory, Oak Ridge, TN 37831, USA; ⁵University of Applied Sciences, Beuth Hochschule f. Technik, FB II, 13353 Berlin, Germany

Superconductor like RRR 300 Nb are standard materials for high-gradient accelerator applications such like superconducting radio-frequency (SRF) systems. These systems are cooled down by liquid helium into the superconducting phase where the electrical resistance drops down to zero. Losses in the rf quality factor Q depend on the surface resistance R_s , which in turn includes a term dependent on trapped flux. [1] By cooling down Nb cavities into the superconducting phase ($T \leq T_C = 9.2K$) surrounding magnetic fields in the amount of the earth field could be trapped inside the cavity walls and cause Q disease. We studied flux trapping process for a RRR 300 Nb disk sample ($r=5mm, h=4.5mm$) treated with buffered chemical polishing (BCP $\approx 150\mu m$) to investigate how flux of a constant homogeneous external field B_{ext} is trapped inside the superconducting bulk. Polarized neutrons are perfect for quantifying trapped flux inside the bulk of a superconducting sample and the surrounding magnetic stray field, because the neutron spin performs Larmor precessions in the B-field. When the neutron spin interacts with the magnetic field, it begins to make Larmor precession, dependent on the magnetic field strength and the path integral $\int \mathbf{B} \cdot d\mathbf{s}$ through the sample. This path-dependent neutron spin rotation is used to visualize the magnetic structure. For a better understanding of the experimentally obtained radiographs we correlate the results with simulated theoretical modeled magnetic field distribution. The magnetic stray field can be described by $\mathbf{H}(\mathbf{r}) = -\nabla \Phi(\mathbf{r})$ (fig. 1a). Further the magnetic field dependent Larmor spin precession of a polarized neutron beam $\mathbf{P}(z)$ through the field can be theoretical calculated by semi-classical spin rotation formalism $d\mathbf{P}(z)/dz = \mathfrak{A}(z) \cdot \mathbf{P}(z)$ where \mathfrak{A} is the \mathbf{B} dependent rotation matrix (fig. 1b). [2,3] In our study we compared simulated polarized neutron radiographs with experimental obtained trapped flux in RRR 300 Nb (fig. 1c) as a function of temperature and magnetic field.

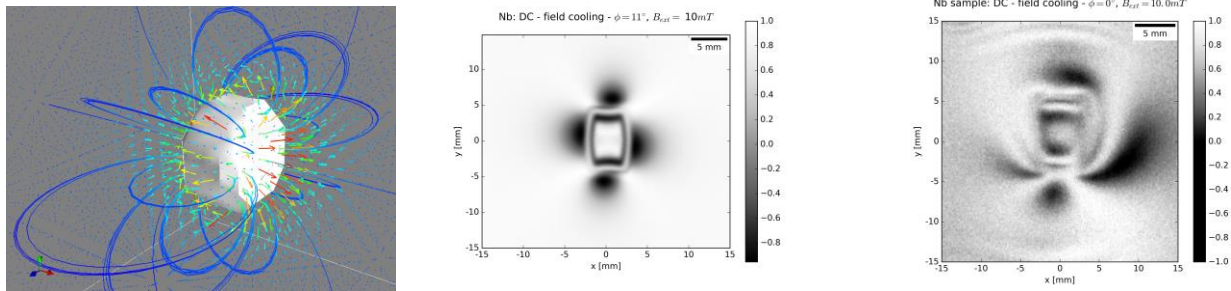

Figure 1: Images of the simulated magnetic stray field (a), the simulated polarized neutron image (b) with $B_{ext} \ll 10.0mT$ which correlates with the experimental obtained image (c) with $B_{ext} \ll 10.0mT$.

References:

- [1] Vogt, J.-M. and Kugeler, O. and Knobloch, J., Phys. Rev. ST Accel. Beams 16, 102002 (2013)
- [2] Engel-Herbert, R. and Hesjedal, T., Journal of Applied Physics, 97 (2015)
- [3] Leeb, H., Hochhold, M., et al, A., Aust. J. Phys., 51, 401-413 (1998)

TaPy - An open and hackable tool for neutron grating interferometry

R. P. Harti, J. Valsecchi, C. Grünzweig

Paul Scherrer Institut, Laboratory for Neutron Scattering and Imaging, 5232 Villigen PSI, Switzerland

Neutron grating interferometry (nGI) data reduction is a computationally driven procedure based on the fitting of individual sinusoidals on grey value oscillations in each pixel. These grey value oscillations are produced by stepping one of the three gratings in traditional neutron grating interferometer experiments and resemble the interference pattern introduced by a phase grating.

With the increased popularity of nGI experiments in recent years the demand for an open and hackable software framework for the data treatment has emerged. We present a python based software solution called **TaPy** that is accessible by anybody and kept simple enough to fully comprehend its inner workings. Thus, it can be modified to handle complex experiments that deliver unique type of data, such as time-of-flight, time resolved nGI or statistical analysis.

The mathematical implementation is based on the algorithm developed by Marathe S., et al.[1]

Using a single matrix multiplication to extract the fitting parameters the algorithm is capable of creating a set of transmission, dark-field and differential phase contrast images as well as visibility maps simultaneously with only a single operation. This efficiency in combination with a memory saving file reading routine makes nGI data reduction fast and easy to use on any local computer/laptop.

TaPy comes with the read-in routines for the most common file formats and the grating interferometer data reduction algorithm as well as some selected processing modules and filters. It is ready-to-use and also encourages the development of individual read-in routines as well as customised pre and post processing modules in python. **TaPy** can be considered a framework for the community of nGI users and operators that allows us to develop and share algorithms and processing procedures while working on the same codebase. We made the software openly accessible on GitHub and invite the community to use it and contribute with new developments.

References:

[1] Marathe, S., Assoufid, L., Xiao, X., Ham, K., Johnson, W. W., & Butler, L. G. (2014). Improved algorithm for processing grating-based phase contrast interferometry image sets. *The Review of Scientific Instruments*, 85(1), 13704. <http://doi.org/10.1063/1.4861199>

Status and research applications of the Neutron and X-ray Tomography (NeXT) system

Jacob M. LaManna, Daniel S. Hussey, Eli Baltic, David L. Jacobson

Physical Measurement Laboratory, National Institute of Standards and Technology, Gaithersburg, MD, USA

Neutrons and X-rays provide complementary non-destructive probes for the analysis of structure and chemical composition of materials. Due to the high sensitivity to hydrogen, neutrons excel at separating liquid water or hydrogenous phases from the underlying structure while X-rays resolve the solid structure. Many samples of interest, such as fluid flow in porous materials or curing concrete, are stochastic or slowly changing with time which makes sequential imaging with neutrons and X-rays difficult as the sample may change between scans. To alleviate this issue, NIST has developed a system for simultaneous neutron and X-ray tomography (NeXT) by orienting a 90 keV_{peak} micro-focus X-ray tube orthogonally to a thermal neutron beam. The NeXT system allows for non-destructive, multimodal tomography of dynamic or stochastic samples while penetrating through sample environment equipment such as pressure and flow vessels. This talk will focus on recent instrument developments and give examples of several application areas.

Absolute determination of low hydrogen concentrations in Zr alloys by wavelength resolved neutron imaging

N L Buitrago^{1,3,4}, A Tartaglione^{2,3}, M R Daymond⁵, A Tremsin⁶, J Kelleher⁷, J R Santisteban^{1,3,4}
¹ Centro Atómico Bariloche, Comisión Nacional de Energía Atómica, Argentina; ² Centro Atómico Constituyentes, Comisión Nacional de Energía Atómica, Argentina; ³ CONICET, Argentina; ⁴ Universidad Nacional de Cuyo, Argentina; ⁵ Department of Mechanical Engineering, Queens University, Kingston, Canada; ⁶ University of California at Berkeley, Berkeley, USA; ⁷ Isis Facility, Rutherford Appleton Laboratory, STFC, UK.

Zr based alloys are widely used in the nuclear industry, in fuel cladding and structural components of nuclear power reactors, because of its low neutron absorption. During reactor operation, Hydrogen (H) enters into Zr based components due to waterside corrosion, and precipitates as a hydride phase that embrittle these alloys even for low H contents. In this work, we have used wavelength resolved neutron imaging experiments to non-destructively determine H content in the 10-500 wt ppm range, with an accuracy of ~15 wt ppm. For this, we have analyzed the wavelength resolved total cross section of Zr alloys and Zirconium hydride, and identified two wavelength intervals to record normalized neutron images that allow a calibration-free determination of H content. These intervals have been chosen to be rather insensitive to microstructural and compositional variations that may occur across real specimens. Experiments were performed at the ENGIN-X beamline of the Isis Facility, United Kingdom, using a micro channel plate (MCP) detector with 55 μ m spatial resolution, and a pixelated glass scintillator with a coarse 2 mm spatial resolution. To validate the method, experiments were performed on a comprehensive set of calibrated, H-charged specimens of Zircaloy-2 and Zr2.5Nb that were destructively analyzed by a standardized technique. The advantages and disadvantages of the technique were analyzed by experiments performed on plates, welds, hydride blisters, and diffusion couples; with traversed thicknesses ranging from 4 mm to 100 μ m.

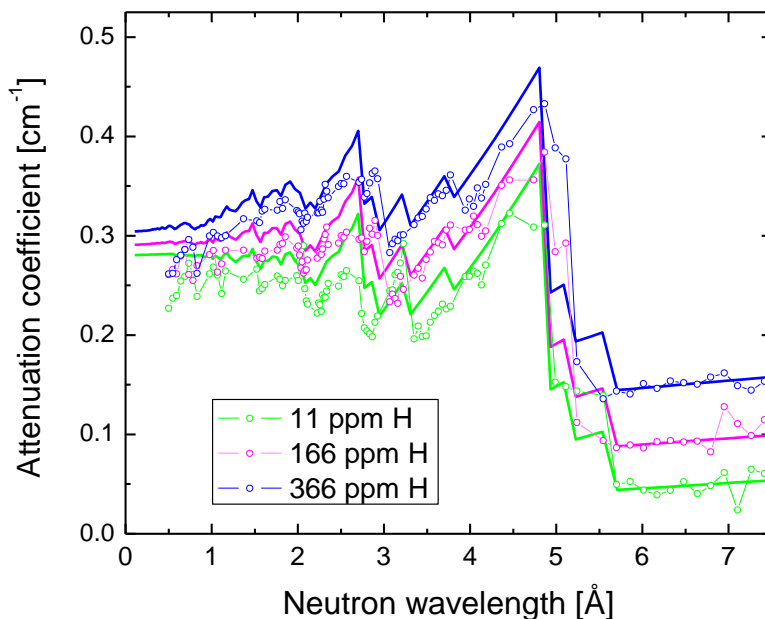

Neutron Radiography with cold, thermal, epi-thermal, and fast neutrons at LANSCE

Sven C. Vogel¹, Adrian S. Losko¹, James Hunter², Michelle Espy², Anton S. Tremsin³, Ron O. Nelson⁴, Mark A.M. Bourke¹, Kenneth J. McClellan¹, Kyle Ramos⁵, David Montgomery⁴, Erik B. Watkins⁶

¹Materials Science and Technology Division, Los Alamos National Laboratory, Los Alamos, NM 87545

²Applied Engineering and Technology Division, Los Alamos National Laboratory, Los Alamos, NM 87545

³Space Science Laboratory, University of California Berkeley, Berkeley, CA 94720

⁴Physics Division, Los Alamos National Laboratory, Los Alamos, NM 87545

⁵Explosive Science and Technology Division, Los Alamos National Laboratory, Los Alamos, NM 87545

⁶Materials Physics and Applications Division, Los Alamos National Laboratory, Los Alamos, NM 87545

In recent years, neutron radiography and tomography was applied at three different beam lines at LANSCE. The field of energy-resolved neutron imaging (ERNI) with epi-thermal neutrons, utilizing neutron absorption resonances for contrast as well as quantitative density measurements, was pioneered at the Flight Path 5 beam line and continues to be refined. Applications include metallic and ceramic nuclear fuels, fission gas measurements, fossils, and scintillators. We were able to characterize materials opaque to thermal neutrons and utilize neutron resonance analysis codes to quantify isotopes to within 0.1 atom %. The latter allowed us also to measure the pressure of fission gas remotely, without the need for a sensor. Since this method is isotope specific, it allows in principle to also measure partial pressures in gas mixtures. More recently, the cold neutron spectrum at the ASTERIX beam line was utilized to demonstrate phase contrast imaging (PCI) with pulsed neutrons. The exploration how pulsed neutrons with the time-of-flight method can provide additional benefits is still on-going. Furthermore, at LANSCE, unmoderated fast neutrons can be used for imaging applications. The former GEANIE beam line is now converted to a dedicated fast neutron imaging beam line with rotation table and imaging detector. We will present application examples and recent results of all these efforts at LANSCE.

LA-UR-17-23826

Bragg-edge analysis using energy-resolved neutron tomography

K. Watanabe¹, W. Kockelmann², T. Minniti², H. Sato³, Y. Kiyanagi¹

¹ Nagoya University, Nagoya, 464-8603, Japan

² STFC, Rutherford Appleton Laboratory, ISIS Facility, Harwell, OX11 0QX, UK

³ Hokkaido University, Sapporo, 060-0808, Japan

Energy-resolved neutron imaging has been a key technology to expand the capabilities in materials science with neutrons. From energy-resolved images, we can get a lot of information using resonance absorption analysis or Bragg-edge analysis. Bragg-edge analysis can extract some information, such as crystal structure, crystalline phase and crystal lattice strain etc., from energy-resolved neutron transmission images. Sato et al. presented that Bragg-edge broadening shows the micro-crystalline structure of the martensite in quenched steels [1]. This technique can apply to not only radiographic images but also tomographic images. In this paper, we demonstrate to extract some information using the Bragg-edge analysis from energy-resolved neutron tomographic images.

Figure 1 shows the radiographic image obtained from a quenched rod using the neutron MCP detector at Larmor beamline in ISIS. The steel rod was quenched from a radially outer surface. The outer region has martensitic crystalline structure. Figure 2 shows the tomographic image reconstructed from projection images of the steel rod in Fig. 1. The tomographic images were reconstructed from each time slice obtained in time-resolved imaging. Figure 3 shows the wavelength dependence of the neutron attenuation strength obtained from the energy-resolved neutron tomographic images. The outer region has a broader edge than the center region due to the martensitic structure.

References:

[1] H.Sato et al., Materials Transactions, 56 (2015) 1147-1152

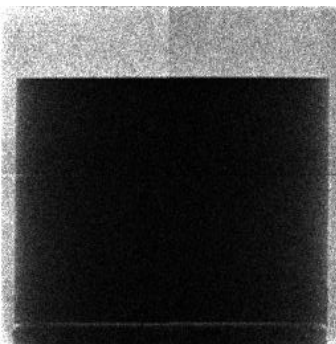

Fig. 1 One of the neutron radiographic images for tomographic measurements of the quenched steel rod.

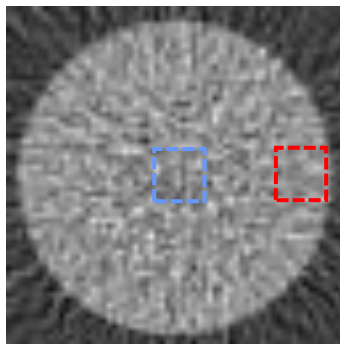

Fig. 2 Neutron tomographic image reconstructed from the projection images of the steel rod in Fig. 1.

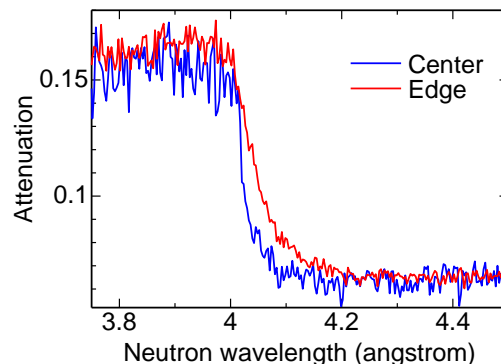

Fig. 3 Wavelength dependence of the neutron attenuation strength averaged in the blue and red dashed squares in Fig. 2.