



VIDEO

# Digital Video Quality Handbook

May 2013



Homeland  
Security

---

Science and Technology

**This page intentionally left blank.**

# CONTENTS

|   |    |
|---|----|
| <b>Contents</b> .....   | 3  |
| 1. Introduction .....   | 5  |
| 2. Acknowledgements .....   | 5  |
| 3. Scope .....  | 5  |
| 4. Compliance and Best Practices .....  | 5  |
| 4.1 Purpose .....   | 6  |
| 4.2 Application .....   | 7  |
| 5. Use Cases.....   | 7  |
| 5.1 Video Surveillance Use Cases.....   | 7  |
| 5.2 Other Use Case Considerations .....   | 8  |
| 6. Equipment.....   | 9  |
| 6.1 Video Surveillance System Classifications .....   | 9  |
| 6.2 Analog Video Systems Overview .....   | 10 |
| 6.3 Network (IP) Video Systems Overview .....   | 10 |
| 6.4 Design of Video Surveillance Systems for Video Quality – Component/Device Categories .....  | 12 |
| 6.5 DMC Source: Network Video Cameras .....   | 15 |
| 6.6 DMC Source: Network Video Encoders .....  | 16 |
| 6.7 Compression Technology Overview .....   | 16 |
| 6.8 Specialty Cameras .....   | 17 |
| 6.8.1 Fixed License Plate Capture Cameras .....   | 17 |
| 6.8.2 Cameras with “True” Day/Night Capability .....  | 17 |
| 6.8.3 Low-Light Network Cameras and Thermal Network Cameras.....                                | 18 |
| 6.9 Lighting .....  | 19 |
| 6.9.1 Color Temperature.....  | 20 |
| 6.9.2 Infrared Illumination .....   | 23 |
| 6.10 Pixels, Imager Sizes, and Sensitivity.....   | 23 |
| 6.10.1 HDTV .....   | 23 |
| 6.10.2 Design of Video Surveillance Systems for Video Quality – Use Cases and Applications..... | 24 |
| 6.10.3 Lighting Level and Resolution Target Test Process.....                                   | 25 |
| 6.10.4 Imager Orientation.....  | 29 |
| 6.10.5 Visual Verification .....  | 29 |
| 6.11 Design of Video Surveillance Systems for Video Quality – Device Groups.....                | 30 |
| 6.12 “Edge” Video Storage Devices .....   | 30 |
| 6.13 Video Surveillance and Cloud Computing.....  | 31 |
| 6.13.1 Software as a Service.....   | 31 |
| 6.13.2 Other Hosted Video Services Considerations .....   | 33 |
| 6.14 Design of Video Surveillance Systems for Video Quality –Interoperability .....             | 33 |
| 6.15 Design of Video Surveillance Systems for Video Quality – Security and Authentication ..... | 34 |
| 6.16 Design of Video Surveillance Systems for Video Quality – Step-by-Step Deployment .....     | 35 |
| 6.17 Video Analytics/Content Analysis .....   | 38 |

|                           |    |
|---------------------------|----|
| 6.18 Video Mobility ..... | 39 |
| 7. Glossary .....         | 41 |

# 1. Introduction

Anyone who has lost connectivity or suffered packet loss while watching a live televised sporting event knows the frustration of missing a key play because of a poor picture. For security practitioners using incident video services, however, a clear picture could mean the difference between pursuit and capture, loss and recovery, or even life and death.

This guidance document—Digital Video Quality Handbook—links a design process with real-life situations that use video in public safety applications, called “use cases,” to the product classes, network infrastructure, and display devices in the solution.

## 2. Acknowledgements

The U.S. Department of Homeland Security Science and Technology Directorate’s (S&T) Office for Interoperability and Compatibility (OIC) would like to acknowledge the Security Industry Association, which supported the development of the Digital Video Quality Handbook. This effort also leveraged the expertise of OIC’s Video Quality in Public Safety Working Group.

## 3. Scope

This document provides voluntary guidance in deploying video quality for network video surveillance applications. All requirements and references stated in this handbook are consistent with established best practices. Nothing in this document is intended to require or imply that commercially available video surveillance systems (VSS) must comply with this handbook and references.

## 4. Compliance and Best Practices

The designer and/or user of VSS needs to consider compliance criteria as a minimum requirement and a starting point for design. Basic requirements dictated by authorities (federal, state, tribal, and local) that have jurisdiction over your industry are a key consideration. This represents a “minimum needs” starting point for specifying both physical and logical security systems involving video surveillance and, ultimately, the achievement of video quality.

Extending surveillance usage into diversified areas of operation, including those that extend beyond traditional fixed infrastructures, will help justify the costs of VSS. Helping the agency or business employ best practices, providing business intelligence to further other agendas, and improving operational safety are all opportunities available to VSS users.

How you balance these opportunities in the design and operation of your VSS depends on the industry in which it is being deployed. Should the designer, installing contractor, or user “cut corners” with the VSS, there must be a degree of protection should critical or life-saving processes depend on VSS usage.

This handbook and references specify public safety’s minimum requirements for design, selection, and deployment of VSS and associated infrastructure devices and components.

Further, this handbook and references specify requirements for new, unused systems; however, the use of Internet Protocol (IP) VSS devices as an upgraded solution may be specified by this handbook and by references as best practice guidance.

The designer is cautioned to verify all interdependencies of devices and services deployed as a separate design or partial VSS upgrade.

This handbook and references should not be understood as addressing all of the safety and liability concerns associated with the use of VSS. Users of this handbook and references should be aware of all safety issues associated with the use of VSS. References that may be used as further compliance verification are cited. The liability of deployment, use, misapplication, partial or full system failure, interdependency on foreign systems, or logical and physical infrastructure should be verified by informed counsel and the appropriate subject matter experts.

Additionally, nothing herein should be understood to restrict any manufacturer from exceeding the requirements of this handbook and references.

This handbook documents best practices of VSS design, system and component selection, deployment, and conformance. The scope of any VSS may be at the component, system, or subsystem level federated or integrated into a larger VSS. The process of federation is especially applicable to VSS city surveillance and public safety applications.

This handbook is primarily focused on network video systems; however, the upgrade of existing analog edge devices, such as analog cameras, will provide functional and digital multimedia content (DMC) distribution improvements to the VSS. Video quality, however, will not be affected. Non-Ethernet digital video, such as High-Definition Closed Circuit Television (HDcctv), represents an alternative to network-based DMC devices, but requires specialized DMC source and recording devices.

Safety is a vital consideration with the deployment of all VSS components and systems; future versions of this handbook will incorporate safety guidance. It is recommended that DMC source devices for exterior applications are sealed from environmental impact and incorporate a minimum Ingress Protection (IP66) rating. Verification of temperature range, change of temperature with time, condensation, vibration, effects of wind, and other external influences must be considered in the achievement of video quality.

## 4.1 Purpose

The purpose of this handbook is to specify a minimum level of performance for a VSS to satisfy a use case.

The designer involved in either the component or system must consider the following to achieve video quality:

- Device categories
- Component and system performance level
- Verification of intended use
- Component and system performance specification
- Best fit and link to use case

## 4.2 Application

This handbook and references applies to VSS deployed for use cases specified. The standard may be applied to use cases not cited; however, device performance in unanticipated conditions and external devices, systems, and infrastructure that have interdependencies must be considered to achieve the highest level of recoverability in the event of power disruptions, network outages, and potential environmental hazards.

## 5. Use Cases

VSS are often called “analog video surveillance” or “IP video surveillance” to indicate their use of conventional or network-based connectivity. The older closed circuit television surveillance term generally indicates analog video surveillance, but can be used to refer to video of all types.

When considering the design and selection of a VSS, the physical security designer, user, or integrator needs to consider the individual needs of each use case and market in which they are working to achieve the highest image quality. The following are intended as examples only and each market’s own requirements should be verified on a project-by-project basis. The term “use case” is an extension of the “application” definition, which is referred to as the combination of hardware, software, and peripheral components that are used to meet a specific use case desired by the implementation of the VSS.

### 5.1 Video Surveillance Use Cases

The following is a summary of the most common use cases, followed by the most common function:

| Use Case                                     | Function   |
|--|--|
| <b>First Responders</b>                      | <ul style="list-style-type: none"> <li><input type="checkbox"/> Provide enhanced video mobility through DMC delivered directly to mobile appliances and matched to the display and appliance capability and resources.</li> <li><input type="checkbox"/> Establish interoperability and convergence between public safety and stakeholders to share information.</li> </ul>  |
| <b>Urban Surveillance</b>                    | <ul style="list-style-type: none"> <li><input type="checkbox"/> Provide low-light capability for all outdoor public video surveillance devices.</li> <li><input type="checkbox"/> Provide cameras capable of producing high-resolution video images and adding a video analytics subsystem when required.</li> <li><input type="checkbox"/> Provide compatibility with fiber optic or wireless transport systems.</li> </ul> |
| <b>In-car and Transit Video Surveillance</b> | <ul style="list-style-type: none"> <li><input type="checkbox"/> Provide the most usable wide view surveillance products for identification.</li> <li><input type="checkbox"/> Provide ruggedized, removable digital media for video storage.</li> </ul>  |
| <b>Public Arenas</b>                         | <ul style="list-style-type: none"> <li><input type="checkbox"/> Provide cameras capable of producing high-resolution video images and adding a video analytics subsystem when required.</li> <li><input type="checkbox"/> Provide low-light and infrared (IR)-compatible cameras where re-</li> </ul>  |

|  |  |
|--|--|
|  | <p>quired.</p> <ul style="list-style-type: none"> <li><input type="checkbox"/> Provide a control system with minimal camera control and switching delay.</li> <li><input type="checkbox"/> Provide ease of expansion to accommodate specialized surveillance of visiting dignitaries.</li> </ul>   |
| <b>Loss Prevention</b>   | <ul style="list-style-type: none"> <li><input type="checkbox"/> Design Point of Sale (POS) transaction data (“Electronic Journal”) with digital video images of the events for simultaneous viewing and transaction proof.</li> <li><input type="checkbox"/> Use input from one or multiple POS and transit pass machines via a RS-232 interface or Ethernet.</li> <li><input type="checkbox"/> Provide simultaneous viewing of time-linked transactions and multiple video cameras.</li> <li><input type="checkbox"/> Provide transaction searching and “go to” next or previous match.</li> <li><input type="checkbox"/> Print transaction reports of retail shrinkage events with linked video images.</li> </ul> |
| <b>Emergency Operations, City Security, and Rail Control Centers</b> | <ul style="list-style-type: none"> <li>• Perform continuous duty.</li> <li>• Provide high-resolution and high-color fidelity, especially in high ceiling areas.</li> <li>• Provide accurate color reproduction.</li> <li>• Provide control system with minimal camera control and switching delay.</li> <li>• Provide video management systems (VMS) or video recording systems (VRS) with instant replay capability for multiple operators and multiple cameras.</li> <li>• Provide redundancy of all operation and equipment capabilities required, especially in high-risk areas.</li> </ul>  |

## 5.2 Other Use Case Considerations

High-quality video can be used to reduce the "shrink," or loss in an operation, through a specialized subset of video surveillance technology — video analytics. Video analytics is an analysis “snapshot” in time; it differs from video content analysis (VCA), which analyzes video data by single or multiple criteria and then delivers a search result. VCA is not to be confused with a newer technology, known as video summarization or synopsis, which condenses an entire day of video to a matter of minutes. Video summarization is based on the movement of objects through tubes; the movement is represented on a condensed video clip along with object time stamps. Should the DMC storage footprint be restricted, the aforementioned technologies permit the opportunity for higher- quality content to be stored in a smaller space. Transportation video surveillance gives us early warning of traffic events and persons in need of assistance and eases normal cyclic traffic flow in major cities. Video surveillance can create a “safe zone” after hours in waiting areas and prevents undesirable events in mass transit systems. Mass transit operators also use



video verification to locate transit vehicles in tunnels. Finally, in-car video surveillance provides the opportunity to replay video content from the time leading up to and after an event, in addition to real-time video observation.

Public safety professionals and first responders use live video feeds from high-definition television (HDTV) cameras to assess an event in progress and determine man-power response. Emergency medical technicians use remotely transmitted video to confirm a diagnosis with a health professional located at a hospital receiving the patient. HDTV cameras record an operation in progress for current observation and future education and distance medical learning.

Perimeter surveillance cameras located at an airport acquire and analyze an unattended vehicle and notify airport law enforcement. Although their camera feeds are not being observed, video analytics within the camera and at a VMS provide real-time notifications of possible threats.

In each of these use cases, video surveillance is used in real-time observation, forensic review, and recognition—the three major use classifications of a VSS. Classifying our system helps us use it more effectively and communicate its primary function as a tool for many professionals, in addition to physical security.

## 6. Equipment

### 6.1 Video Surveillance System Classifications

By classifying VSS by function, we are reminded to think first of the benefit to the user (rather than the technology itself). If the solution has interesting features but does not make sense for the actual use case, the designer has not adequately identified the video surveillance user's needs.

As stated above, the three primary classifications of VSS are observation, forensic review, and recognition. Systems meant for observation do not have the same high-resolution requirements as recognition, but require high-frame (refresh) rates. Systems used primarily for review after an incident occurs must have excellent coverage and a frame rate high enough to capture an event. The wide (16:9) aspect ratio of HDTV is often an excellent solution for these types of systems as they give the user the best opportunity to provide evidence. Recognition-based solutions or systems that analyze video and provide a result, like license plate capture or recognition, require the highest resolution or amount of “pixels on target”. See the illustration in figure 1 for the effect of pixels-on-target on image quality.



Figure 1: Effect of Pixels on Image Quality

A way to deploy recognition-based systems and conserve storage or bandwidth is to provide a trigger to activate the recognition-based recording, such as installing a vehicle loop detector and activating a camera that performs a license plate recognition function.

## 6.2 Analog Video Systems Overview

If a system is primarily used for observation or surveillance, design emphasis placed on the viewing refresh rate will be beneficial. Minimizing the control latency (both camera control delay and switching delay) is extremely important and one benefit offered by an analog system. Most IP video systems can provide smooth, lag-free control of cameras that are able to be positioned or pan-tilt-zoom (PTZ) cameras, but this needs to be verified under a variety of network-usage scenarios.

One of the most challenging tasks for a surveillance operator is trying to follow a subject using a PTZ camera on a network-based video system that was not designed with a fast control response in mind. Today's analog-based systems are, in some cases, more costly to deploy and use proprietary cabling infrastructure (such as coaxial cable). They are suitable for small "closed" systems where remote access is not required, and while they are limited in video quality, they offer a way to minimize control signal delays, even if a comparable network-based system is used for transport or dedicated communications are used.

## 6.3 Network (IP) Video Systems Overview

Video over IP is best defined as the deployment of video information over a network that conforms to the Open Systems Interconnection (OSI) layer model, a standards communications model produced by the International Organization for Standardization (ISO). This includes support of cameras and encoders that transmit using standard network protocols like transmission control protocol TCP/ internal protocol (IP), user datagram protocol UDP, and file transfer protocol FTP. Devices that "stream" video over IP networks transmit frames and packets of video data to a single location or multiple locations for different purposes. A device like a network video camera or multi-channel video encoder can send a video stream to a single network video recorder (NVR) or video decoder location or to multiple locations of the same type of equipment.

In many cases, there is a lower total cost of ownership for the life cycle of the system. With a network infrastructure in place, there are lower installation costs when power over Ethernet (PoE, 802.3af) devices are used, eliminating the need and vulnerability of localized power supplies. An end user can enjoy reduced operational overhead as the IP video devices are accessible at any location on the network. The IP video system devices often require less maintenance and system downtime; however, the designer is cautioned to ensure support for the shared infrastructure, such as network switches and recording servers, is in place. If not, the IP video system can actually be far more costly to operate and maintain.

The typical IP video system is deployed and expanded much more quickly and easily as the initial infrastructure investment has been installed and future devices are connected to the nearest network access location, which is usually the telecommunications room. Considering this, installation of point-to-point infrastructure where a facility has changing requirements makes the deployment of an IP video system a more feasible alternative.

Live or recorded video that can be reviewed anywhere at any time from any geographic location permits a better use of the overall video system investment. IP video systems are essential parts of public surveillance systems, such as city center security and mass transit, as there may be an instantaneous requirement to view a single camera by one or many individuals simultaneously.

“Open” infrastructure permits the integration of video surveillance devices from different manufacturers; however, the designer is cautioned that challenges similar to the analog video system exist where interoperability is required. Even though the transport is standardized with IP video, manufacturers often use different video compression engines in the video source that must be decoded by the recording and control system.

There is an accepted method of exchanging software development kit (SDK) and application programming interface (API) information between manufacturers; some have even standardized on a single API to ease the burden on the developer. Choosing a network camera with a strong partner program is like buying an investment in a platform. There are many developers that have created unique and creative solutions that can best meet individual requirements. Purchasing a network camera from a manufacturer with less development partners will significantly limit the number of different recording and monitoring solutions you may use.

Standards of interoperability help the decision process of a network camera selection, but the designer must be ready to score compliance with required standards of interoperability. It is important to remember that there is no partial compliance; a solution either conforms or it does not.

Assuming that integration is proceeding, it is far easier to link disparate systems to a single platform. The integration of related systems, including access control, intrusion, fire/safety, and communication can provide for beneficial interoperability.

Higher-end imaging technologies like megapixel and progressive scan are available in IP video systems and represent a distinct advantage over their analog counterparts. It is necessary to keep in mind that many of the specialized imaging technologies still remain analog and must be converted to IP video through the use of video servers or encoder devices. Megapixel and progressive scan imaging make it easier to identify objects and individuals in recordings than in their nearest equivalent analog counterparts, assuming the same imaging technologies are used in both devices. Megapixel imaging technologies are not yet standardized; therefore, it is recommended that the HDTV standard, a subset of megapixel imaging, be used wherever possible. A non-Ethernet digital standard known as HDcctv can also provide image quality similar to HDTV, but at a higher cost and only to limited infrastructure types due to the requirement of specialized equipment.

Direct attached storage (DAS) and storage area networks (SANs) are easily scalable and provide future growth for the IP video platform, as they can be placed and managed at or from any accessible location on the network. With IP video, there is a need to reduce the risk to your facility’s infrastructure, so best practices for network security usually place devices like IP video well behind corporate firewalls; as a result, IP video is not generally accessible to the public.

Should the IP video device be publicly accessible, the network security risks become much more prevalent. Some of the risks can include compromised video integrity through manipulation of the video images or the breach of infor-

mation systems to which the VSS is connected. Other risks include denial of service as the IP video camera will only support a finite number of users directly. There is also the risk of taking control of the device itself and redirecting the video stream elsewhere, leading to unauthorized access and possible destruction of stored video data within the camera. It is for this reason that many manufacturers have adopted the use of Port Authentication Protocol (802.1x) to better manage video streaming and accessibility of the recording and monitoring devices that exist directly on a corporate network. The designer is cautioned, however, to model all systems that utilize authentication protocols to assure the level of performance that the user requires.

Current evolving capabilities that further extend the security framework of VSS network infrastructure components include creating a “trust model,” or high assurance identity and access control framework, that uses a security technique known as public key infrastructure, or PKI, to implement cryptographic requirements for authenticating Non-Person Entities (NPEs) such as cameras or other DMC sources. Through PKI, video is encrypted during transmission over fixed and wireless networks, as well as stored in mobile, network-attached, or cloud-hosted storage repositories.

Authenticating NPEs in accordance with certificate and credentialing management standards are under development and will permit these devices to attain high trust levels and deliver DMC to users on public or private networks.

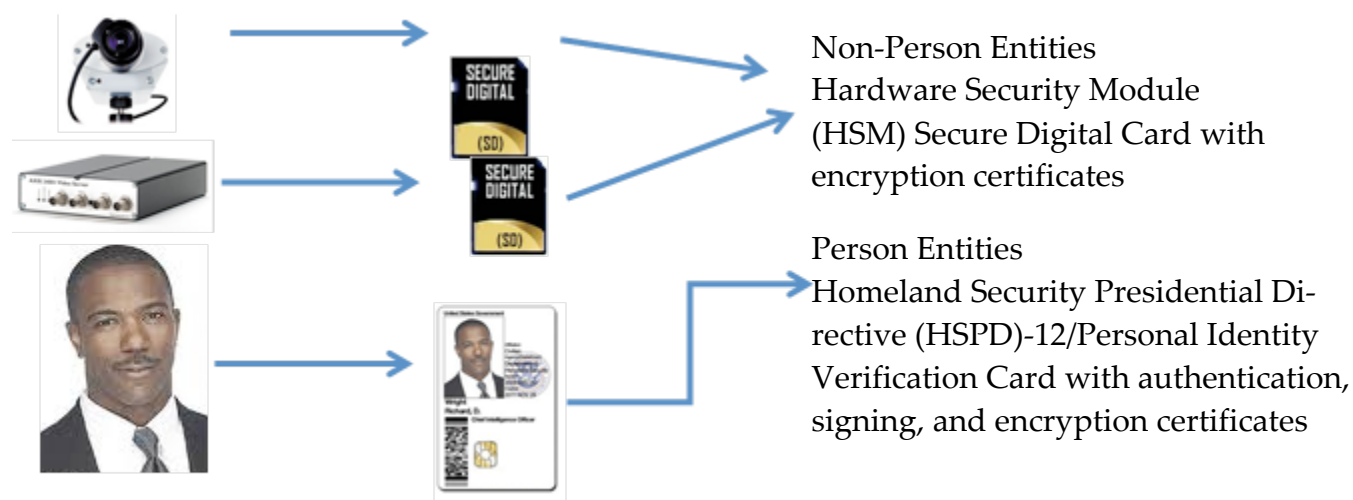

**Figure 2: Representative Credentialing – Non-Person Entity vs. Person**

## 6.4 Design of Video Surveillance Systems for Video Quality – Component/Device Categories

When designing a system to achieve desired video quality, a practitioner must take the following three steps:

- Categorize components.
- Select the highest-performing devices, infrastructure, or services for the given budget.
- Assure/verify interoperability, compatibility, and delivery of the DMC per the user’s requirement.

For example, take a small recording solution for a stand-alone facility such as a small data center that requires no remote access. DMC recording must be of the highest quality but related to the retention of events only; those events are triggered by an external source.

For those requirements, the design considerations to achieve maximum quality can be the following:

- ❑ Lighting: as required to produce usable video quality, such as local, motion-activated white light-emitting diode (LED) fixtures
- ❑ DMC Source: network camera with built-in removable storage
- ❑ DMC Authentication: network camera with cryptographic authentication, time stamping, and metadata
- ❑ Physical Infrastructure: local Ethernet cabling
- ❑ Logical Infrastructure: network switch with multi-port 802.3af PoE capability
- ❑ VMS: offline application connected on forensic review of events
- ❑ Storage: optional, local network attached storage (NAS)

Another example of an application similar to the above but with remote access required, such as video accessibility through smartphone applications, could include:

- ❑ Lighting: as required to produce usable video quality, such as local, motion-activated white LED fixtures
- ❑ DMC Source: network camera with built-in removable storage, continuous secondary recording in the event of wide-area-network (WAN) outage
- ❑ DMC Encryption: network camera that stores encrypted data from DMC sources
- ❑ Physical Infrastructure: local Ethernet cabling
- ❑ Logical Infrastructure: network switch with multi-port 802.3af PoE capability
- ❑ VMS: provides software as a service (SaaS) through a managed portal from a service provider (SP)
- ❑ Storage: required, local NAS
- ❑ Display: mobile appliances, remote desktop computer access portal

A larger solution for public safety in a specific area of a dense metropolitan area could include:

- ❑ Lighting: existing, with specific improvements for higher-crime areas with white LED fixtures
- ❑ DMC Source: network camera with built-in removable storage, continuous secondary recording in the event of infrastructure outage
- ❑ DMC Authentication and Encryption: network camera with cryptographic authentication and encryption
- ❑ Physical Infrastructure: primary fiber infrastructure with secondary wireless cellular network, or primary MESH multiple-input and multiple-output (MIMO) wireless infrastructure
- ❑ Logical Infrastructure: remote Layer 2 network switches or local MESH MIMO combination radio and L2 switch with multi-port 802.3af PoE capability
- ❑ Control/Analysis: keyboard/joystick access, automated analytics advanced video motion detection, cross-line detection object left behind, fixed vehicle license plate recognition/capture applications
- ❑ VMS: centralized command center with automated rules engine
- ❑ Storage: required, local NAS
- ❑ Display: Command Center display array controlled directly by the system's rules engine or physical security information management (PSIM) gateway application; mobile appliances with smart transcoding

Figure 3 illustrates a framework of VSS components for selection by use cases:



**Figure 3: Video Surveillance System Components**

Using the examples above, a worksheet can be generated that summarizes each VSS component location and use:

|                             | Lighting/Environment                 | DMC Source                        | Physical Infrastructure | Logical Infrastructure | Control/Analysis   | VMS             | Systems Integration | Storage                                       | Display       |
|-----------------------------|--------------------------------------|-----------------------------------|-------------------------|------------------------|--|-----------------|---------------------|---|---------------|
| <b>Perimeter Camera</b>     | Continuous High-Pressure (HP) Sodium | Network Camera, Fixed, HDTV 1080p | Fiber to Camera         |                        | Cross-Line Detection, Fixed License Plate Recognition  |                 |                     | Local Secure Digital (SD) Card for Event, NAS |               |
| <b>Interior Grid Camera</b> | LED                                  | Network Camera, Fixed, HDTV       | Fiber to Camera         |                        | Advanced Visual Molecular Dynamics VMD, Object Left Behind                                       |                 |                     | Local SD Card for Event                       |               |
| <b>Command Center</b>       |                                      |                                   |                         |                        | Smart Search, License Plate Capture Search, Advanced VMD Search, Cross-Line Detection Activation | Centralized VMS |                     |   | Display Array |

**Figure 4: Video Surveillance System Planning Worksheet**

Today’s video solutions market brings an application and platform for virtually every end-user requirement. For small systems (less than 16 network cameras) primarily suited for forensic use and compliance, and for instances where Internet access is unavailable, recording of network video at the “edge” is becoming more popular amongst practitioners.

Managed or hosted video solutions deployed in public or private clouds represent a strong recurring monthly revenue opportunity, mobile device access, and a cost-effective way to accommodate smaller quantities of cameras that are geographically dispersed.

When you need to verify video or associate video, voice, or other emergency data with intrusion detection systems, the central station “automation” segment is essential and even deployed in a “proprietary” fashion by large communities of end users. With the efficiencies of today’s central station owner/operator, however, it is almost always a best practice to use these professional service providers rather than invest in a self-deployed solution.

Appliance-type digital and NVRs are a cost-effective, useful, but narrow fit for mid-range systems (48 cameras or less) and provide less interoperability or third-party solution integration than the large VMS segment.

When managing video as data from campus to city security and surveillance applications, a VMS provides user friendly and scalable opportunities. Many of these VMS solution providers are providing a “hybrid” centralized and

managed services solution. This accommodates many corporate security professionals who must also protect smaller “satellite” facilities and data centers. Meeting the needs of the end user having disparate systems and desiring a single interface or “gateway” to manage events, some VMS providers provide PSIM functionality.

In many cases, end users in specific markets move to either central station automation functions provided as a service or the PSIM application deployed in their facility. Both solution classes can provide robust functionality, improved situational awareness, and third-party notification.

## 6.5 DMC Source: Network Video Cameras

Security practitioners and designers must routinely specify outdoor camera solutions for varying applications and often don’t have the man-power or time to test capability, resolution, performance, cost-to-performance ratio, network security, and compliance with their own company network. In addition, physical security departments are continually asked to justify expenditures by making the investment useful to other departments within the organization.

A useful solution is to select an advanced network camera with the highest level of compliance with network standards. In addition, use of HDTV surveillance with its standardized resolution, frame rate, and color fidelity make certain cameras the most advanced outdoor devices on the market today. One best practice is to verify the camera’s platform is able to support embedded applications. These platforms create a “future-proof” investment and permit video analytics solution providers to develop and embed into the camera or VMS people-counting, object-tracking, and recognition applications as well as abnormal behavior recognition programs. In addition, having the recording capability built into the camera in the form of a Secure Digital/Secure Digital High Capacity (SD/SDHC) memory card slot is useful in the event of a network outage; it also enables users to create a self-contained recording system or provide authentication or encryption of video data transmitted from the DMC source.

A sample list of features to verify a network camera will typically include:

- ❑ Imager with usable response for day and night use, color and black/white
- ❑ Wide focal length range for maximum magnification
- ❑ Conformance to HDTV standards in camera package
- ❑ Compliance with network security standards
- ❑ “Green” device is powered directly over Ethernet cable; no need for external power supplies
- ❑ Internal Memory Recording for covert applications and in case of outage
- ❑ Withstands widest temperature ranges

There may not be an “ideal” camera that delivers every function. Practitioners should perform the DMC source/camera selection by matching available features to the required use case, together with the highest level of information technology (IT) and industry interoperability compliance.

Some network video cameras include advanced features, like object detection algorithms, and can capture metadata at the video source for later processing by NVRs or image processing servers. There is a wide range of developers that offer algorithms for use in these cameras. There are also emerging frameworks that are gaining rapid acceptance across industry for interoperability between network device categories. One such specification, which is widely used

in the network video space, is maintained by the Open Network Video Interface Forum (ONVIF) and provides an extremely useful baseline for interoperability between network video components.

## 6.6 DMC Source: Network Video Encoders

Often referred to as single- or multi-channel video encoders or video servers, network video encoders convert video from analog cameras into multiple video streams that may be accepted by NVRs or the control command center. An encoder is usually a four- or six-channel device that may be placed near the analog camera or at some distance to accommodate placement in a telecommunications room.

Single-channel encoders are useful for small analog video deployments that can be upgraded to IP video. Multi-channel encoders provide fast, reliable, customized video services to closed-communities with an integrated, cost-effective platform and deliver specialized video services with high-performance edge-channel insertion and replacement.

Encoders are available as a stand-alone module; rack-mounted device; or card-type module that is a “blade” inside a larger, rack-mounted storage device.

These encoders support a number of PTZ camera control protocols. The encoder may support PTZ signals that are multiplexed over the coaxial cable or connected via serial.

## 6.7 Compression Technology Overview

Network video solutions are enabled through the increasing efficiency of network camera compression schemes. Video compression in network video cameras is performed using either h.264 or Motion JPEG codecs.

The latest iteration of MPEG-4—MPEG-4 Part 10, h.264, or the Advanced Video Codec (AVC)—is the most efficient compression technology to date. To view compressed video, it is necessary to decode it. Fixed and mobile devices today typically decode h.264 video streams. Previously thought to be too complex and processor intensive, h.264 decoding is now so common that the designer has the choice of using software or hardware decoders, allowing DMC to be viewed everywhere there is Internet or network connectivity.

An open, licensed standard, H.264 supports the most efficient video compression techniques available today. Without compromising image quality, an h.264 encoder can reduce the size of a digital video file by more than 80 percent compared with the Motion JPEG format and as much as 50 percent more than with the MPEG-4 Part 2 standard. This means that much less network bandwidth and storage space are required for a video file. Or seen another way, much higher video quality can be achieved for a given bit rate. Even several years after maturity, h.264 compression continues to improve. VMS solutions now require less computing power to decode multiple streams encoded with h.264 compression, further lowering costs.

A best practice is to use direct digital outputs from decoding appliances to match the resolution of DMC capture to display device(s). The two types of DMC display interfaces available are Digital Visual Interface (DVI) and High-Definition Multimedia Interface (HDMI). Component and S-video connectivity should be avoided as these are analog interfaces and will degrade the DMC source and, therefore, the video quality on display.



## 6.8 Specialty Cameras

### 6.8.1 Fixed License Plate Capture Cameras

Fixed license plate capture (LPC) cameras are specifically designed to capture license plate information for processing by a license plate recognition (LPR) system. They have similar components to stand-alone IR or “true” day/night DMC cameras. Many vehicle tags have a reflective coating that is sensitive to IR illumination; therefore, these tags present an excellent opportunity to perform access control and visitor tracking in a passive manner. Today’s LPR/LPC algorithms may be applied to network cameras and VMS without having to specify these purpose-built LPR cameras.

### 6.8.2 Cameras with “True” Day/Night Capability

Also known as color/black-and-white cameras, these have the capability to view near-visible IR light, usually in the range of 850 to 880 nanometers (nm). This is the most common and recommended application; however, covert IP surveillance is possible with the use of DMC cameras and matched IR illumination in the 950 nm wavelength. These cameras may be used alone or together with an external IR illuminator that is sensitive in that range. Incandescent-based IR lighting solutions present danger due to the heat and IR radiation, especially when mounted at a low height. LED-based illuminators do not have this problem.

One of the most versatile features of many of today’s fixed and PTZ cameras is the “day/night” feature. The camera that has auto and manual color-to-black-and-white capability first senses a low-light condition that would be better accommodated by a black-and-white mode. The camera then automatically removes its built-in IR cut filter, improving its sensitivity to light in that spectrum. The camera can then automatically turn on an IR illuminator and capture in near darkness (see figures on page 20).



**Figure 5: Day/Night Camera Imager IR Cut Filter Engaged**



**Figure 6: IR Cut Filter Removed**



**Figure 7: Before LED Lighting Deployment**

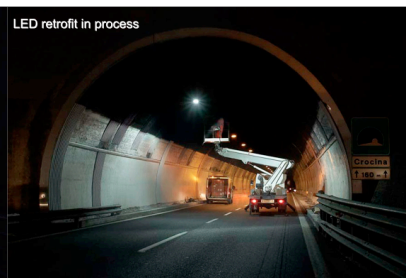

**Figure 8: After LED Lighting Deployment**

Parking garage images before and after LED conversion (original is high-pressure sodium lighting); Source: BetaLED



**Figure 9: Before LED Retrofit**



**Figure 10: LED Retrofit in Progress**



**Figure 11: LED Conversion Complete**

Source: BetaLED

Some cameras offer an increased sensitivity mode and black-and-white capability, but do not have a removable IR cut filter. These cameras are not sensitive to IR illumination and are generally a poor selection for an IP video surveillance device.

### 6.8.3 Low-Light Network Cameras and Thermal Network Cameras

With sensor improvements and powerful image processing a reality in today’s network cameras, dramatic advancements in reproducing poorly lit scenes are being realized. Improved noise reduction and color make today’s low-light network camera a significant cost savings opportunity.

In situations where auxiliary lighting is required, covert and semi-covert IR illumination extends the “true” day/night network camera’s application range.

Lower cost thermal network cameras extend the perimeter surveillance range of many facilities to areas of foliage where vulnerabilities existed previously.

Thermal cameras capture heat or temperature values of a scene rather than light values, regardless of how bright or dark the scene appears to the human eye. Although the identification of colors and details are impossible with thermal cameras (because they view temperature only), these cameras are especially useful in viewing dark scenes for activities that have heat signatures.

Security practitioners and designers must routinely specify outdoor camera solutions for varying applications; they also need a camera that can supplement visual and physical perimeter facility patrols. Thermal imaging cameras have been too costly a solution in the past, but now there are products using uncooled thermal imagers that might have a shorter maximum range (1500'), but at about 25 percent of the cost of their cooled imager counterparts.

As a guideline, a typical feature set for specifying advanced, yet cost-effective network thermal cameras includes:

- Ability to stream multiple, independent, different-colored streams so you can have the best chance at seeing an “invisible” intruder
- Video motion detection, active tampering alarm, and audio detection
- Support for video analytic algorithm platforms that enable embedded applications like cross-line and trip-wire
- Compliance with network protocols
- “Green” device is powered through Ethernet cable; no need for external power supplies
- Internal memory recording for covert applications and outage protection

To achieve maximum video quality, thermal imaging cameras are ideal for high-risk applications like borders and embassies when paired with an HDTV day/night network camera.

## 6.9 Lighting

The lighting requirements for a video surveillance system depend on the sensitivity of the imaging devices, the functional use of the video surveillance system, and the existing lighting at the facility. Luminance is used to describe reflected light from flat surfaces and is measured in lux ( $lx = lm/m^2$ ); it is also the method of measuring the sensitivity of a video surveillance imaging device.

Because a video surveillance device depends on reflected light, those surfaces that have greater reflective capability will allow this device to better reproduce images. When designing a video surveillance system for a parking area, for example, the relative reflective properties of asphalt and concrete must be considered, with concrete being the “brighter” surface of the two. What does this have to do with lighting and the video surveillance camera? You will need more light with surfaces like asphalt that have lower reflective qualities to produce the same images that another camera produces near concrete surfaces.

The most efficient deployment of lighting for video quality in physical security applications is white LED illumination; this option provides the greatest return on investment over three years or more.

LED lighting is one of video surveillance’s most powerful tools, for three reasons:

- Higher color temperature, higher color rendition, and color fidelity with even distribution on higher-end fixtures
- Lower energy consumption and total cost of ownership when the total fixture life is considered
- LED products can last ten times the life and have much lower maintenance when compared with popular high-intensity discharge lamps (HID lamps) and sodium vapor lighting fixtures

## Total Cost of Ownership: HID vs LED

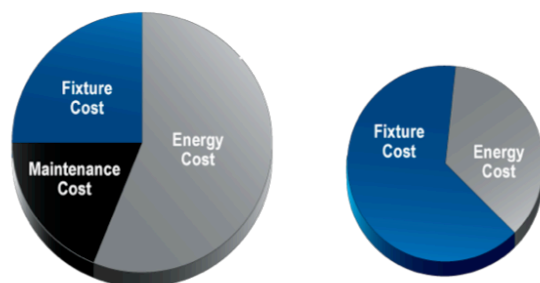

**Figure 12: Comparison, Total Cost of Ownership, LED Lighting**

Source: BetaLED

When used together with a DMC HDTV camera, LED luminaires achieve the highest video quality and energy efficiency over a lifetime cost of ownership. The total cost of HID fixture ownership is greater than for LED luminaires because of higher energy and maintenance costs. With LED products, the initial fixture cost is a greater percentage of the cost, but the overall total cost of ownership is smaller than for HID lighting. Both have higher color temperature than high- and low-pressure sodium vapor lighting fixtures that contribute to lower video quality.

### 6.9.1 Color Temperature

Color temperature is an important consideration when selecting lighting. Color temperature is expressed in units called kelvins (K). The color that a black body radiator glows when it is at a specific temperature is the color temperature of a light source. Some light sources are ideal for reproducing details, especially those greater than 3000° K. There may be aesthetic advantages to light sources that have color temperatures less than 3000° K, but they are not associated with the improved video quality details that higher color temperature light sources produce. Light sources able to produce detailed images suitable for forensic review, identification, and recognition have a high Color Rendering Index (CRI), as illustrated in figure 14.

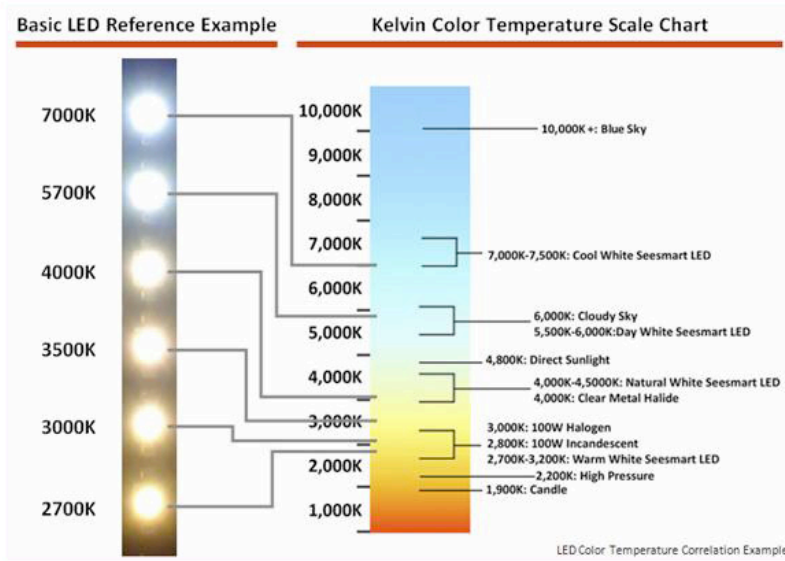
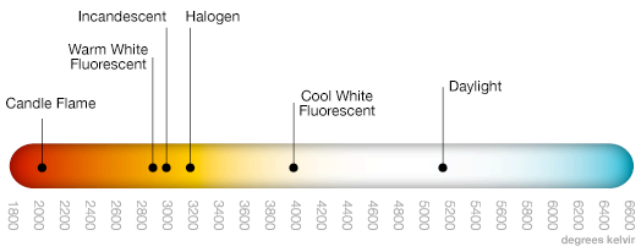

Figure 13: Color Temperature Scale

Source: www.OMSlighting.sk

**Color Temperature...**



**Lighting Type**

**Color Rendition Index**

**Relative Image Reproduction**

|               |       |              |
|---------------|-------|--------------|
| Daylight      | 100   | Excellent    |
| Incandescent  | 97    | Excellent    |
| Fluorescent   | 87-94 | Excellent    |
| Halogen       | 90-97 | Excellent    |
| LP Sodium     | 5     | Poor         |
| HP Sodium     | 30    | Poor => Fair |
| Mercury Vapor | 43    | Poor => Fair |
| Metal Halide  | 70    | Good         |

**...is independent of the Color Rendering Index.**

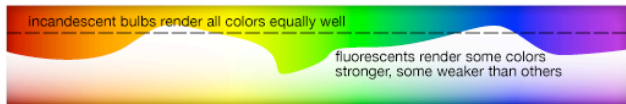

Figure 14: Color Rendering Index

Figure 15: CRI and Image Reproduction

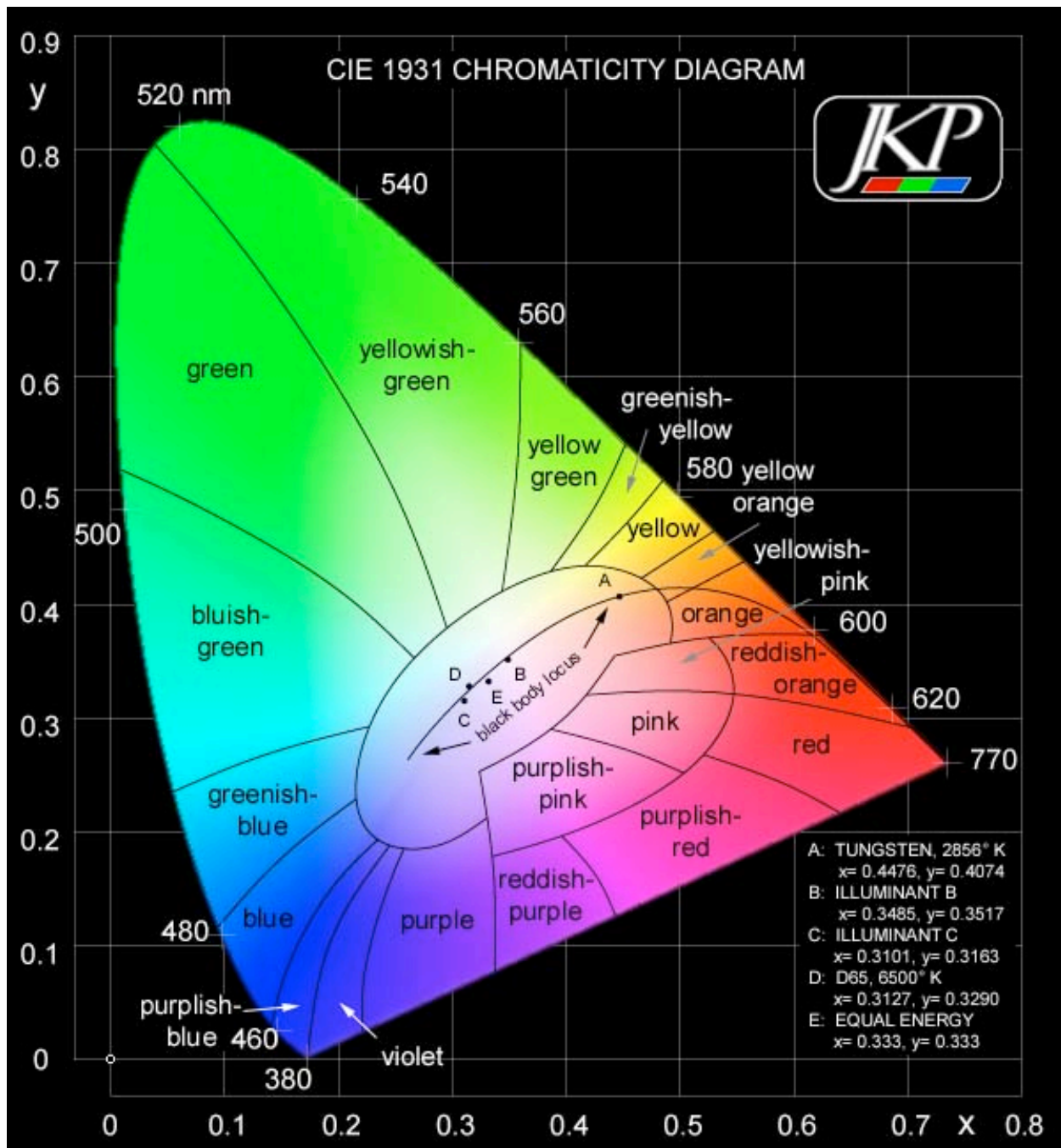

Figure 16: HDTV Reference Chart

Source: [International Commission on Illumination](http://www.cie.co.at/)

White LED illumination, either through area lighting or short-distance supplemental illumination, should be considered whenever possible, especially where HDTV cameras can take advantage of the scene's wide dynamic range and reproduce images with high color fidelity.

## 6.9.2 Infrared Illumination

IR illumination is an excellent tool to add directional and flood lighting to key areas. Most day/night cameras in their black-and-white mode are sensitive to the near-visible (850 nm) and invisible (950 nm) IR light that today's IR illuminators provide, making IR a low cost way of supplying additional light at night. As stated earlier, the IR illuminator must be matched to the imaging device to assure compatibility. That said, there are some cameras that are sensitive to both wavelengths and that should be selected for maximum compatibility.

## 6.10 Pixels, Imager Sizes, and Sensitivity

### 6.10.1 HDTV

HDTV is a standard that has positively impacted the video surveillance industry and therefore guarantees the expectation of video quality, frame rate, and color fidelity. HDTV is no more complex than multi-megapixel imaging and provides a more convenient and economical solution as video surveillance for observation, forensic review, and recognition has a higher probability for successful deployment.

HDTV, or just HD, refers to video having resolution substantially higher than traditional television systems (standard-definition television [TV], SDTV, or SD). High definition (HD) has at least one or two million pixels per frame; roughly five times that of SD.

HDTV provides up to five times higher resolution than standard analog television. HDTV has better color fidelity and a 16:9 format. The two most important HDTV standards today are SMPTE 296M and SMPTE 274M, which are defined by the Society of Motion Picture and Television Engineers (SMPTE).

HDTV broadcast systems are identified with three major parameters:

- "Frame size in pixels" is defined as number of horizontal pixels  $\times$  number of vertical pixels (e.g.,  $1280 \times 720$  or  $1920 \times 1080$ ). Often, the number of horizontal pixels is implied from context and is omitted.
- "Scanning system" is identified with the letter P for progressive scanning or I for interlaced scanning.
- "Frame rate" is identified as number of video frames per second. For interlaced systems, an alternative form of specifying the number of fields per second is often used.

If all three parameters are used, they are specified in the following form: [frame size][scanning system][frame or field rate] or [frame size]/[frame or field rate][scanning system]. Often, frame size or frame rate can be dropped if its value is implied from context. In this case, the remaining numeric parameter is specified first, followed by the scanning system.

For example, 1080i30 or 1080i60 notation identifies an interlaced scanning format with 30 frames (60 fields) per second, each frame being 1,920 pixels wide and 1,080 pixels high. The 720p60 notation identifies a progressive scanning format with 60 frames per second, each frame being 720 pixels high.

Images and video clips from HDTV and quality multi-megapixel devices are more usable when they come from devices that meet standards. Public safety professionals are now using HDTV because they have seen demonstrations

and sample video clips that demonstrate use cases, like monitoring critical events for first responders, operating room surveillance, and transportation security.

The deployment of MESH wireless networks and the availability of network infrastructure of all varieties will not only encourage use of HDTV, but make it a device that is normally deployed alongside a network switch.

Adoption of HDTV benefits multiple applications, including city center surveillance, medical operating rooms, remote diagnosis, and transportation (mass transit and airport surveillance).

Automated recognition-based systems that use video analytics perform more effectively on an HDTV platform, and these cameras typically have stronger processors, so they can run analytics and stream video effectively. Video analytics allow a guard force to be more aware of abnormal events by allowing HDTV systems to handle the burden of many routine tasks. For example, an HDTV camera, together with an access control device, can admit returning contractors without the need for operator interaction. Security operators can be proactive with other tasks, thereby reducing man-power costs.

With the use of h.264 video compression, bandwidth consumption is drastically reduced with HD cameras. Packaging of HD cameras is now available in fixed box style, fixed dome, and PTZ camera form factors.

If the use case requires higher resolution or more pixels-on-target, then market share will increase from that application. Video analytic algorithms run better with higher quality imaging and forensic review gets performed more easily.

Public safety, law enforcement, and medical applications all benefit from the use of HDTV video, and with more efficient compression technologies like h.264, the deployment of HDTV is often a first choice when selecting a network camera.

Different network cameras, whether HD or not, use different compression engines and can therefore, at times, be an interoperability challenge. However, this challenge can be overcome through the use of a standardized API. In addition, interoperability alliances like ONVIF create common ways for network cameras to bind with the video management system.

## **6.10.2 Design of Video Surveillance Systems for Video Quality – Use Cases and Applications**

The VSS must present a scene of interest to a user in sufficient detail to make a decision or perform a task based on recognition of what is happening in the scene. For example, the end user must be able to read the characters in a license plate or determine the identities of individuals at a local convenience store while performing surveillance.

The VSS should be designed to accomplish one or more specific tasks regarding a scene. The primary function of the VSS should be identified as observation, forensic review, or recognition. The scene should be identified to include one or more areas of interest or scene content.



The VSS scene content criteria should incorporate resolution, object size, speed, trajectory, scene lighting level, and required refresh rate.

Resolution as required by the VSS primary function should be measured in pixels per foot (ppf). The ppf calculation should be derived for both horizontal and vertical pixels and is equal to the imager's pixel dimensions divided by the corresponding field of view linear dimension (feet).

The use of video cameras and encoding technology with built-in pixel counting should be considered as an enhancement to the design process, measurement, and verification of pixels on target.

The size of the object(s) in the scene content should be considered in the design of the VSS and related to the VSS primary function. Smaller objects will require higher resolution image capture. Video cameras with image capture characteristics complying with image quality standards are recommended, such as HDTV. HDTV video cameras should be required in VSS where the object(s) of interest occupy 10 percent or less of the field of view. For objects occupying 25 percent or less of the field of view, HDTV video cameras should be recommended.

### 6.10.3 Lighting Level and Resolution Target Test Process

The lighting level should be considered in the VSS design process. The ability for the video camera or encoding device to render images that match the VSS primary function should be considered. Lighting is measured as reflected and the scene environment should be considered along with the scene's light sources. The designer should verify the performance of the video camera or encoding device to produce suitable images for observation, forensic review, or recognition functions through site testing with actual test objects or test charts to include, but not limited to: ISO 12233 Digital Imaging Test Chart, ISO Camera Test Charts, and ACCU-CHART HDTV Test Chart (figures 17 through 21).

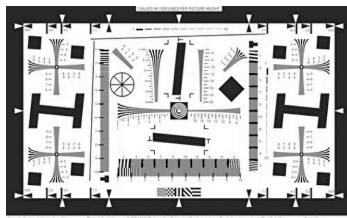

**Figure 17: ISO 12233 Digital Imaging Test Chart**

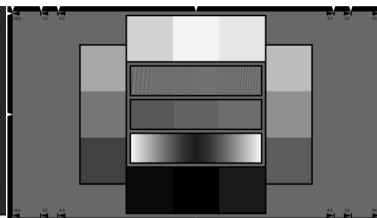

**Figure 18: ISO 15739 Gray Scale Test Chart**

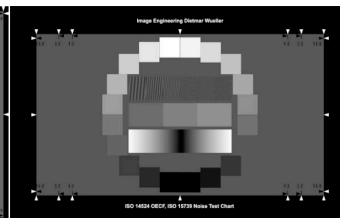

**Figure 19: ISO 14524 Noise Chart**



**Figure 20: Color Fidelity Chart**

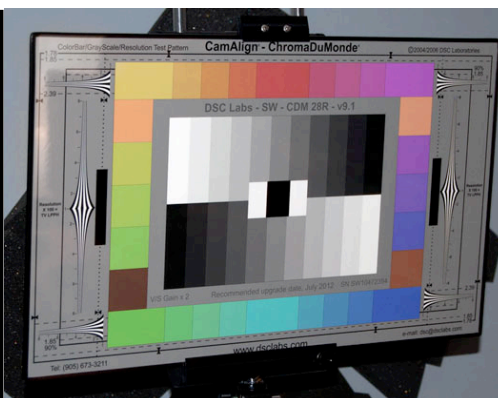

**Figure 21: CamAlign ChromaDuMonde Chart**

The refresh or display rate in frames or images per second (fps) for the VSS function should be matched for the display size. Mobile devices with smaller display resolution should require a lower minimum frame rate for the VSS function; larger displays should require a higher frame rate.

The display rate for the VSS function should be matched to the percentage that the object(s) of interest occupy within the field of view, as well as the object's speed and trajectory.

For subjects traveling in speeds over 40 miles per hour (mph) and occupying greater than 10 percent of the viewing area, use of both MJPEG and h.264 compression encoding is recommended. For recording subjects exceeding the same relative speed on board a moving craft or vehicle, also use dual encoding.

The primary VSS functions should be described as follows:

- VSS designed for the observation function should be optimized to provide continuous viewing of scene content captured by the video camera or encoding device and displayed on local or remote monitors or on remote display devices like smartphones, tablets, or laptop computers.
  - The minimum resolution should be 20 ppf to achieve a VSS observation function using imaging standards like HDTV, whereas non-standard cameras should pass the lighting level and resolution target test processes.
- VSS designed for the forensic review function should be optimized to provide high-resolution recording of scene content or DMC captured by the video camera or encoding device. The DMC should have resolution high enough to permit general identification of scene content or object(s) of interest; identification of object colors; and specific identification of an object's characteristics, the time, and the location of the objects in the DMC.
  - The minimum resolution should be 40 ppf using imaging standards like HDTV to achieve a VSS forensic review function. Non-standard cameras should pass the lighting level and resolution target test processes.
- VSS designed for the recognition function should depend on the specific recognition function required for the use case. Recognition functions should include, but not be limited to: vehicle license plate recognition, facial recognition, face location, smoke and fire detection, object recognition, pattern recognition, cross-line

detection, object temporal characteristic, color recognition, and trajectory. The designer should verify the performance of the video camera or encoding device together with the recognition application to produce suitable data through site testing with actual test objects.

- The minimum resolution should be 80 ppf using imaging standards like HDTV to achieve a VSS recognition function. Non-standard cameras should pass the lighting level and resolution target test processes.

Maximum field of view charts should be generated and used for each type of imager format and VSS function specified.

**VSS Function: 4:3 Imager**

**Surveillance Video Function / Resolution / Maximum Field of View**

| SURVEILLANCE VIDEO FUNCTION | RESOLUTION        | HORIZONTAL RESOLUTION | VERTICAL RESOLUTION | MAXIMUM HORIZONTAL FIELD OF VIEW | MAXIMUM VERTICAL FIELD OF VIEW |
|-----------------------------|-------------------|-----------------------|---------------------|----------------------------------|--------------------------------|
|                             | (PIXELS PER FOOT) | (PIXELS)              | (PIXELS)            | (FEET)                           | (FEET)                         |
| OBSERVATION                 | 20                | 640                   | 480                 | 32                               | 24                             |
|                             | 20                | 1024                  | 768                 | 51                               | 38                             |
|                             | 20                | 1280                  | 960                 | 64                               | 48                             |
| FORENSIC REVIEW             | 40                | 640                   | 480                 | 16                               | 12                             |
|                             | 40                | 1024                  | 768                 | 26                               | 19                             |
|                             | 40                | 1280                  | 960                 | 32                               | 24                             |
| RECOGNITION                 | 80                | 640                   | 480                 | 8                                | 6                              |
|                             | 80                | 1024                  | 768                 | 13                               | 10                             |
|                             | 80                | 1280                  | 960                 | 16                               | 12                             |

**Figure 22: Field of view; pixels on target, 4:3 Imager**

| SURVEILLANCE VIDEO FUNCTION | RESOLUTION        | HORIZONTAL RESOLUTION | VERTICAL RESOLUTION | HORIZONTAL FIELD OF VIEW | VERTICAL FIELD OF VIEW |
|-----------------------------|-------------------|-----------------------|---------------------|--------------------------|------------------------|
|                             | (PIXELS PER FOOT) | (PIXELS)              | (PIXELS)            | (FEET)                   | (FEET)                 |

| SURVEIL-<br>LANCE VIDEO<br>FUNCTION | RESOLUTION | HORIZONTAL<br>RESOLUTION | VERTICAL<br>RESOLUTION | HORIZONTAL<br>FIELD OF<br>VIEW | VERTICAL<br>FIELD OF<br>VIEW |
|-------------------------------------|------------|--------------------------|------------------------|--------------------------------|------------------------------|
| OBSERVATION                         | 20         | 1280                     | 720                    | 64                             | 36                           |
|                                     |            | 1920                     | 1080                   | 96                             | 54                           |
| FORENSIC REVIEW                     | 40         | 1280                     | 720                    | 32                             | 18                           |
|                                     |            | 1920                     | 1080                   | 48                             | 27                           |
| RECOGNITION                         | 80         | 1280                     | 720                    | 16                             | 9                            |
|                                     |            | 1920                     | 1080                   | 24                             | 24                           |

Figure 23: 16:9 Imager Chart

| SURVEIL-<br>LANCE VIDEO<br>FUNCTION | RESOLUTION           | HORIZONTAL<br>RESOLUTION | VERTICAL<br>RESOLUTION | HORIZONTAL<br>FIELD OF<br>VIEW | VERTICAL<br>FIELD OF<br>VIEW |
|-------------------------------------|----------------------|--------------------------|------------------------|--------------------------------|------------------------------|
|                                     | (PIXELS PER<br>FOOT) | (PIXELS)                 | (PIXELS)               | (FEET)                         | (FEET)                       |
| OBSERVATION                         | 20                   | 720                      | 1280                   | 36                             | 64                           |
|                                     |                      | 1080                     | 1920                   | 54                             | 96                           |
| FORENSIC REVIEW                     | 40                   | 720                      | 1280                   | 18                             | 32                           |
|                                     |                      | 1080                     | 1920                   | 27                             | 48                           |
| RECOGNITION                         | 80                   | 720                      | 1280                   | 9                              | 16                           |
|                                     |                      | 1080                     | 1920                   | 24                             | 24                           |

Figure 24: 9:16 Imager Chart

Example: Calculating a surveillance requirement using pixels on target, in a bank, requiring facial identification:

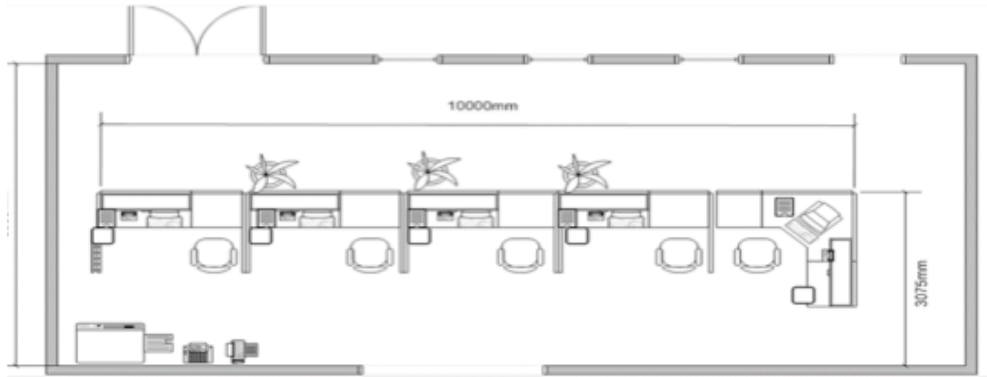

**Figure 25: Sample Teller Line for Pixels on Target Example**

The average human face is 6.3 inches wide

Recommendations for face width for positive ID varies from 60 to 80 pixels

32 ft or 384" of bank teller station requires how many pixels across?

384" \* 60 pixels /6.3 inches per face ~ 3660 pixels (low end)

384" \* 80 pixels/6.3 inches per face ~ 4875 pixels (high end)

What is the number of video surveillance cameras covering the area?

To find the number of cameras, divide the pixel width across by the horizontal camera resolution (640 x 480 camera)

$3660/640 = 5.7$  cameras for the required pixel density (low end)

$4875/640 = 7.6$  cameras for the required pixel density (high end)

## 6.10.4 Imager Orientation

The designer should use a DMC source with an imager's aspect ratio matched to the subject area for maximum coverage of pixels on target. For example, should an interior hallway or corridor be the subject, a 9:16 imager should be used. A wide area with horizontal dimension as the greatest should be viewed and recorded using a 16:9 imager format.

## 6.10.5 Visual Verification

The designer should consider visual verification of image quality using normative resolution and visual acuity tools available where possible. In the cases of public safety, homeland security, port security, critical infrastructure, video surveillance used for remote healthcare, and all video surveillance applications used by first responders, the designer should refer to the Video Quality in Public Safety guidance on achieving video quality.

The designer should consider the minimum image quality requirements to optimize recognition and identification, including video format, audio format, metadata formats, multiplex and transport protocol, and data security and integrity.

## 6.11 Design of Video Surveillance Systems for Video Quality – Device Groups

The designer should identify the devices necessary to achieve the VSS use case and accommodate the user’s total cost of operation (TCO) requirements. The devices required for a given use case should vary and depend on the VSS geographic dispersion, number of video cameras or encoders, and specialized DMC or video content management.

For the use case requiring greater than five sites and low or non-existent VSS control and analysis, the designer should configure the VSS as one of the following minimum device configurations: DMC source; VSS physical infrastructure; VSS logical infrastructure; VSS video management; and DMC storage.

The VSS video management should be an NVR, VMS application, or combined cloud-based video management and storage application/service.

For the use case where the jurisdiction requirements require DMC to be stored off-site due to theft concerns, the designer should specify the combined cloud-based video management and storage application/service.

For the use case requiring less than five sites and medium-to-high VSS control and analysis, the designer should configure the VSS as one of the following minimum device configurations: DMC source/VSS physical infrastructure/VSS logical infrastructure/VSS video management/DMC storage.

The VSS video management should be a VMS application, PSIM system, or digital data management system.

The designer should specify DMC storage to accommodate user compliance requirements. Facilities processing personally identifiable information and conforming to the PCI-DSS, SAS70, and Statement on Standards for Attestation Engagements (SSAE) 16 standards for physical and logical security should require a minimum of 90 days DMC retention, unless otherwise directed by those standards. If the system requires remote viewing or if the solution uses managed or hosted video, the designer should verify that the end user’s connectivity (upstream bandwidth) can support these requirements. Remember that mobile devices require lower resolution and network attached storage can accept an HDTV stream while a lower resolution stream is sent to the remote user or the managed video service.

For the use case requiring no interdependencies from multiple facility locations, less than 48 cameras and minimal VSS control and analysis, and local DMC storage, the designer should configure the VSS to include a DMC source, VSS physical infrastructure, VSS logical infrastructure, VSS video management, and DMC storage.

## 6.12 “Edge” Video Storage Devices

“Edge” small and stand-alone video surveillance systems are often an extremely cost-effective method of securing smaller facilities. Driving this technology adoption are use cases; for example, there may be a requirement to track controlled substances and increased data center compliance requirements with the SSAE 16 standard.

A large installed base of aging digital video recorder (DVR) appliances are forcing practitioners to either replace these with newer versions or attempt upgrades on an older platform. Today, the network video camera, enabled by higher capacity internal removable solid state storage can store one to two weeks of HDTV video. Even higher capacity, lower-cost local NAS devices can supplement this internal storage and allow a standardized and easily maintained replacement of legacy DVRs.

## 6.13 Video Surveillance and Cloud Computing

In order to understand video surveillance's evolutionary move to hosted environments for particular use cases, we need to first define "cloud computing" and "virtualization." Cloud computing is a model for enabling ubiquitous, convenient, on-demand network access to a shared pool of configurable computing resources (e.g., networks, servers, storage, applications, services) that can be rapidly provisioned and released with minimal management effort or service provider interaction. (This definition is from the latest draft of the National Institute of Standards and Technology's (NIST) Working Definition of Cloud Computing). Virtualization is the process of simulating "virtual" versions of infrastructure resources, such as operating systems, storage devices, or network components.

### 6.13.1 Software as a Service

Software as a Service (SaaS) is a cloud-based service model that has significantly impacted video surveillance by moving software to a "hosted" or "managed" video portal. Delivered by video hosting service providers, these services provide significant advantages to certain video surveillance applications. The advantages include: Automatic upgrades Trace One innovates constantly, and those innovations can be made immediately available without the need for re-installing or re-configuring; and Provides high security access to sensitive data; and maximizes document reuse.

The video hosting systems deliver monitoring and recording via cloud computing, but still deliver the latest camera technology to the end user via hosting providers at a substantial cost savings. Some of the advantages end users and public safety professionals will experience for these geographically-dispersed small systems include:

- Automatic binding of the camera to the managed video site allows for a simpler installation.
- Video content stored in the cloud, in addition to local NAS devices, reduces the possibility of lost or stolen evidence.
- High-definition video is recorded directly from the camera to an optional NAS device placed anywhere at the facility or exterior locations. As solid state storage becomes more readily available in high capacities, the requirement for NAS device deployment decreases because local recording functions are now inside the camera itself.
- Encryption of stored video in the cloud provides security in multi-tenant, shared hosting facilities.

The three steps to binding a hosted video camera to a portal are as follows:

1. Connect the camera to a network switch or WiFi router.
2. Program the camera identification information at the monitoring facility or central station.
3. Monitor real-time or recorded video on any platform, including laptops, desktop computers, or mobile devices via a browser.

There may be significant benefits to the public safety professional for deploying these solutions, including:

- No software upgrades or anti-virus software are required for the duration of service.
- Mobile and remote devices like BlackBerry®, Android, iPhones, iPads, and laptops are supported directly from an Internet site: you still get alarms and real-time and recorded video even if local storage is damaged.
- Reduced installation time should be realized due to binding the network camera to the hosted portal.
- SaaS works with existing infrastructure five ways (see figure 26)
  1. Wired Ethernet (preferred)
  2. Existing analog cameras
  3. Wireless Ethernet
  4. Ethernet over power line
  5. Fiber optic cable (preferred for outdoor applications)

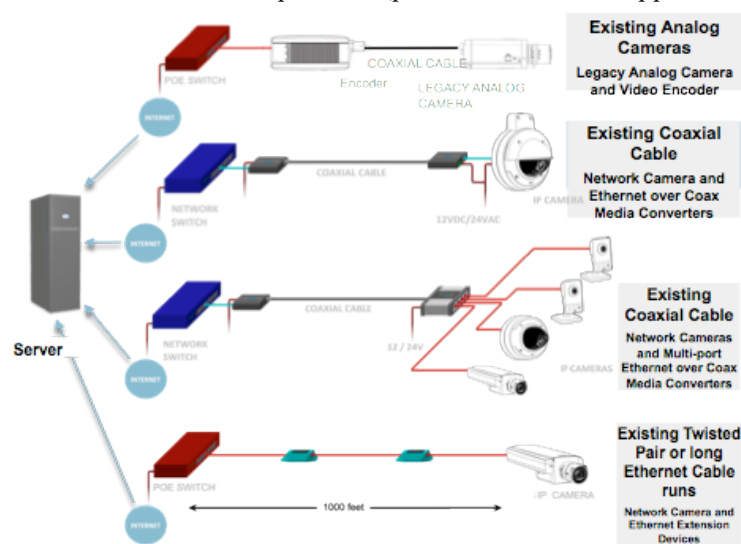

**Figure 26: Infrastructure Migration Diagram**

When compared with a replacement DVR system, the public safety user can take advantage of substantial savings, standardized video content formats, and improved accessibility. HDTV cameras have a higher bandwidth stream that is sent locally to a NAS. The NAS is also there to record if the Internet connection ever fails. Larger groups of end users and public safety professionals can deploy this on their own network and achieve even greater cost savings.

Advances in technology have improved storage on the network cameras themselves. The use of removable SD and micro SD media as event and short-term primary storage is extremely favorable and may be considered to supplement and, in some cases, replace the NAS device. This device becomes a “solid state DVR” onboard the camera; it can support video content available to “trickle” back to a centralized video management system. As near-field communications (NFC) mature, these stand-alone recording devices will become more popular and cost effective, permitting authenticated mobile devices to retrieve event video clips as required.



Hosted video solutions represent a growing market as they are low cost, technologically superior, geographically dispersed, small in size, and an easy solution for VSS. The user simply needs to decide whether to deploy the solution themselves or through service (hosting) providers. Aging DVRs that require an upgrade can be complete in 25 percent of the time, compared with conventional analog solutions.

### **6.13.2 Other Hosted Video Services Considerations**

The International Association of Chiefs of Police recently reported that over 75 percent of all dispatch requests are the result of user error. It is the responsibility of the public and private sectors to explore every possible reduction method and examine the viability of all technologies and procedures. Video verification is becoming a requirement in many jurisdictions.

The statistics of our global aging population are alarming. In May 2011, the first of 77 million baby boomers in the United States turned 65. Every day, over 12,000 people in the U.S. turn age 62. Today's Personal Emergency Response Systems (PERSs) are allowing seniors to maintain dignity in their lifestyle without compromising their safety.

In both the video verification of intrusion alarm and PERS cases, video surveillance and recorded event clips of alarm conditions positively contribute to public safety and are growing trends.

The Central Station Alarm Association (CSAA) and its members have taken a strong leadership position in providing the industry with leadership in both standards, including a video verification standard, and solutions. CSAA has also formed a Video Monitoring Working Group. There is a growing need for end users and solution providers to match their needs with services that involve video surveillance, recorded video for forensic use, automated video recognition, and event (verification)-based video. One of the Video Monitoring Working Group's first tasks will be to define all services available in applicable industries that incorporate or integrate video/digital multimedia content. "Digital multimedia content" is defined as including the video content itself, plus associated metadata (feature data) and audio.

For example, one of these services is alarm-based video verification. Another is "remote guarding" or "guard force automation." There are many more and this group's first charter will be to develop a visual services "map" for CSAA members and their customers to use as a navigation and specification aid.

## **6.14 Design of Video Surveillance Systems for Video Quality – Interoperability**

All VSS devices should conform to an interoperability test as determined by the designer. Where possible, devices conforming to the ONVIF should be considered as long as the VSS device manufacturer can provide proof of the specification conformance test tool. Devices used that do not conform to ONVIF should demonstrate interoperability via a manufacturer's API, which should be in place via an established partner program.

## 6.15 Design of Video Surveillance Systems for Video Quality – Security and Authentication

Both physical security and IT professionals place great importance on cyber security. Network video surveillance systems are comprised of “edge” devices like network cameras and encoders that produce video content and metadata and provide for control, analysis, media search and content management, storage, and display components. Physical and logical infrastructure provides connectivity between categories and also conforms to useful standards like 802.1x, or port-based network access control. This ensures a user or device cannot make a full network connection until they are properly authenticated.

All of the aforementioned video solutions simplify surveillance, but what about data security complexity? Considerations of data storage privacy, geography, and security must be considered. The transmission security of video data must be maintained. One example secures both the producer and consumer of video data with a network camera and mobile device with a trusted and established Certificate Authority (CA). This CA allows the security director to simply and efficiently establish or revoke the privilege of DMC sources to produce, store, play back, and display video content. It’s difficult to compromise (hack) and is auditable; strong; and scalable for chain of custody, confidentiality, and asserting the authenticity of video.

The power and sophistication of today’s network video camera is increasing, making them small computers complete with solid-state storage, room for onboard security and video content analysis “apps,” and enhanced image processing. Improving the fidelity of the video content right at the source provides the security industry with problem-solving technologies like wide dynamic range and improved ultra-low light performance. With more important processes related to these “non-person entities” and edge devices, it is vital that they be resistant to intrusion exploits and they achieve a trusted identity that can be proven similar to that of an individual’s passport.

NIST recently published an educational video illustrating how the National Strategy for Trusted Identities in Cyberspace (NSTIC) will work. NSTIC’s goal is to establish identity solutions and privacy-enhancing technologies that will improve security by authenticating individuals and infrastructure. In this structure, the user proving their identity and the provider issuing a trusted credential follows the selection of secure and independent identity providers.

Applying this structure to network video, cameras run a cryptographic application that communicates to a digital certificate authority that registers, validates, and has the capability to revoke the network device’s access to core digital video services. Just like the mobile banking customer, the network video camera will “prove” its identity through this validation process. “Non-person entities” can also include voice over IP (VoIP) communications, electronic access control readers, intelligent perimeter sensors, and mobile devices. A secure application on a smartphone can initiate a payment of funds to an establishment’s owner/operator and decode video and statistical content, such as customer volume, from the “meta” or “feature” data.

The specification of a network video surveillance system architecture and function, together with the authentication requirements, can enhance the definition of use cases.

The network video authentication requirements for the ideal public safety application are as follows:

- Verify the network video plus metadata or DMC source(s) with Network Intrusion Detection Systems (IDSs) and Network Management Systems (NMSs) for authorized consumption of network resources.
- Provision the DMC source(s) appropriate network resources in accordance with NMS and Quality of Service (QoS) definitions.
- Verify the DMC user/consumer(s) (like smartphones and workstations) with IDS and NMS for authorized consumption of network resources and access to DMC source(s). Process DMC source(s) Public Key Infrastructure (PKI) certificate(s) and validate or reject, as required.
- Provision DMC user/consumer(s) appropriate network resources and DMC source(s) access in accordance with NMS, QoS definitions, local and global Rules, and CAs. Establish the validity of the identity credential presented as part of the authentication transaction. Process DMC user PKI certificate(s) and validate or reject as required using revocation status checking and certificate path validation.

Only after the identity credential is bound to the NPE will the DMC user/consumer(s) be permitted access to live or recorded content.

The validation of trusted network devices also makes bandwidth management easier and is a logical companion to network management systems.

## 6.16 Design of Video Surveillance Systems for Video Quality – Step-by-Step Deployment

The following is an overview of significant video surveillance system design tasks:

1. The designer should perform a video site survey, identify camera functions, and consider multiple VSS functions.
2. The designer should assess the lighting conditions, measure the reflected light at the facility during various times of day, and recommend DMC sources capable of rendering usable images with the available illumination and satisfying the primary VSS function. The designer should also assess the DMC source device compatibility with the color temperature of the reflected light and CRI of the illumination for compatibility. Use of illumination with a high CRI should be recommended. Where illumination is either unavailable or creating a poor image as rendered by the DMC source, the designer should consider the use of IR illumination, HDTV devices capable of low-light conditions, or network-based thermal imaging cameras of the uncooled sensor type and capable of multiple palette rendering, verifying compatibility with the VSS primary function. IR illumination should be used in the 850 nm wavelength where possible; the designer should deploy network cameras capable of rendering images illuminated by either 850 nm or 950 nm covert IR illuminations to maintain maximum VSS flexibility.
3. The designer should assess the existing or proposed infrastructure/system architecture/network topology/protocol support and determine the impact on the VSS. The designer should also implement the use of DMC NPE security framework when high assurance is required.
4. The designer should recommend specific physical infrastructure improvements as part of the current design or separate project, capital project, or periodic expansion to accommodate the requirements of the VSS. The designer should provide guidance for infrastructure life-cycle management or the continuous assessment of

the facility’s transport system to maintain compatibility with the VSS bandwidth, user access, infrastructure-delivered power, and scalability requirements.

5. VSS devices should be considered to be powered devices (PDs) and be provisioned, powered, and connected to Ethernet cabling that conform to the IEEE 802.3af and 802.3at standards. All powered source equipment (PSE) should deliver the power on request from a compatible VSS PD and maintain operation supervised by an external management system. Critical failures such as PSE device failure should be monitored by the owner or end user’s information management, IT, or systems solutions staff. “Hi PoE” and “High Power PoE” designations for PD and PSE should be considered manufacturer specific and not used where devices compliant with IEEE 802.3af and 802.3at standards are available. Deployments at higher power levels than these standards must always be accompanied with an analysis of cable, cable installation, supporting cable accessories, local compliance, and dedicated data cables, negating any temperature concern and guaranteeing safe and consistent operation.
6. The designer should consider systems external to the VSS to manage power and connectivity where possible. These systems should be known as infrastructure management systems and should provide intelligent patching and provision services, using the network to aggregate power usage reporting. The infrastructure management system should be necessary for systems expected to exceed 20 percent expansion.
7. The designer should specify the resolution and image refresh rate for DMC sources, according to the use case requirement.
8. The designer should provide the necessary data to make use of a user’s existing network; estimate bandwidth using approved manufacturer tools and verify with average site conditions with scene motion; get individual values; and prepare bandwidth use and overlay on a network device map. See sample “Public Safety Video Bandwidth Estimates:”

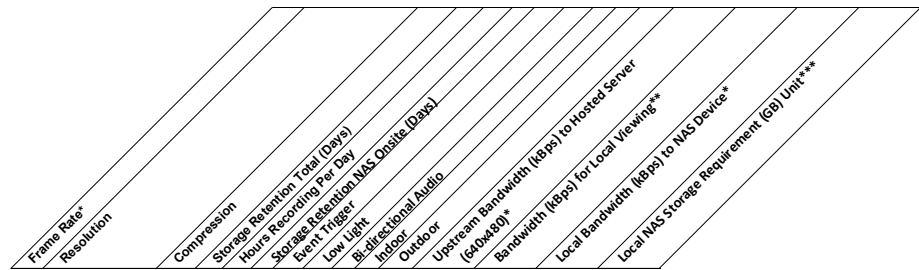

**HOUSING AUTHORITY RESIDENCE**

|  |    |                |       |    |    |   |     |  |  |     |     |      |      |       |
|--|----|----------------|-------|----|----|---|-----|--|--|-----|-----|------|------|-------|
| Entrance                                       | 6  | 1280x720p HDTV | h.264 | 30 | 24 | 7 |     |  |  | Yes | 448 | 1340 | 1340 | 102.0 |
| Perimeter, with Outdoor White LED Illumination | 12 | 640x480        | h.264 | 30 | 24 | 7 | Yes |  |  | Yes | 787 | 787  | 787  | 11.9  |
| Rear/Service Entrance                          | 12 | 640x480        | h.264 | 30 | 24 | 7 | Yes |  |  | Yes | 787 | 787  | 787  | 11.9  |

**CITY SURVEILLANCE**

|   |    |                 |       |   |    |   |     |  |     |      |      |      |       |
|---|----|-----------------|-------|---|----|---|-----|--|-----|------|------|------|-------|
| Fixed Camera, Exterior HDTV                         | 12 | 1280x720p HDTV  | h.264 | 7 | 24 | 7 | Yes |  | Yes | 787  | 2360 | 2360 | 179.0 |
| Fixed Camera, Exterior, Low Frame Rate HDTV         | 6  | 1280x720p HDTV  | h.264 | 7 | 24 | 7 | Yes |  | Yes | 448  | 1340 | 1340 | 102.0 |
| Low Light PTZ Camera, HDTV Exterior High Frame Rate | 24 | 1280x720p HDTV  | h.264 | 7 | 24 | 7 | Yes |  | Yes | 1340 | 4020 | 4020 | 304.0 |
| Low Light PTZ Camera, Exterior 1080p                | 12 | 1960x1080p HDTV | h.264 | 7 | 24 | 7 | Yes |  | Yes | 787  | 5310 | 5310 | 402.0 |
| Low Light PTZ Camera, Exterior 720p                 | 6  | 1960x1080p HDTV | h.264 | 7 | 24 | 7 | Yes |  | Yes | 448  | 1340 | 1340 | 102.0 |

\*Average upstream bandwidth; in case of event trigger, 20% event frequency assumed. Highest activity and lowest compression (highest quality) assumed

\*\*Based on local frame maximum programmed frame rate

\*\*\*Local storage

**Figure 27: Bandwidth Estimates, Public Safety**

9. The designer should verify expected protocol compliance and performance with the user's network or IT professional (make sure bandwidth needs and protocol requirements match the infrastructure).
10. The designer should verify users are satisfied with the consuming device's rendering of video quality, intended use, and expected performance. The designer should verify server performance and modify VSS as required. The designer should consider all possible resolutions and match them appropriately with the public safety application. Figure 27 summarizes available display device resolutions.
11. The designer should finalize an equipment list, merging components into assemblies by function/purpose.
12. The designer should create a matrix of VSS uses and stakeholder responsibilities, which addresses the following areas: responsible, informed by responsible group, provides input, and support to group responsible.
13. The designer should make use of virtual local area networks (VLANs) and Quality of Service (QoS) as much as possible to ensure minimal impact on shared infrastructure. Dedicated infrastructure should only be used when the designer has shown the shared infrastructure is over capacity or over-utilized for the use case and the security management program or risk assessment requires the same.
14. The designer should use these documents, agree on the division of responsibilities, identify primary stakeholders, and develop a comprehensive commissioning statement.

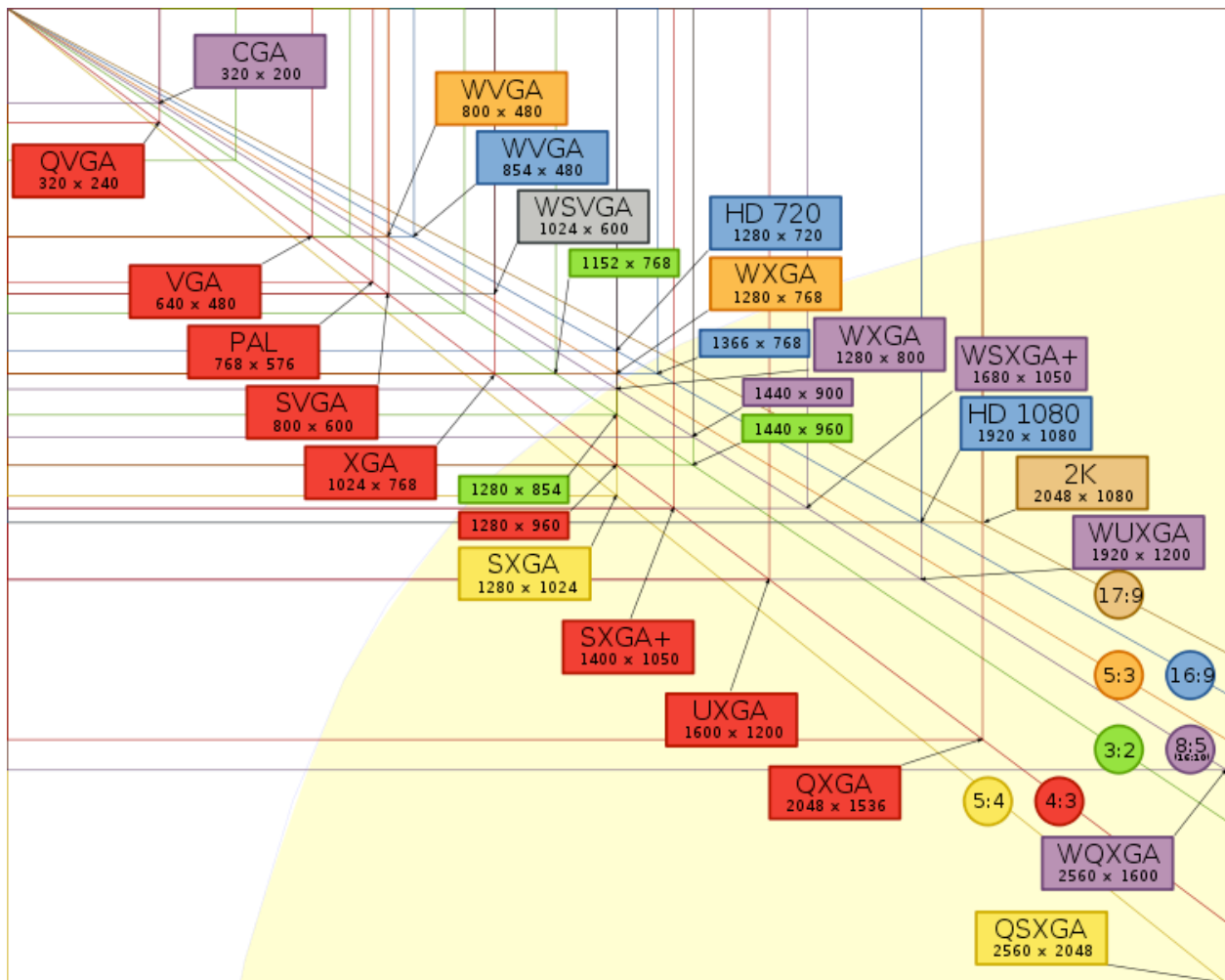

**Figure 27: Summary of Display Resolutions** Digital Video Quality Handbook

Source: Vector Video Standards, public domain

When applying the appropriate video stream to the receiving or consuming device, it is required that the content be formatted, delivered, or “intelligently transcoded” according to the display capabilities of the receiving device, the use case, connectivity, and required resolution to achieve high-quality video. See figure 28 for a summarization of device types, screen resolutions, and guidance for DMC content minimum display resolution.

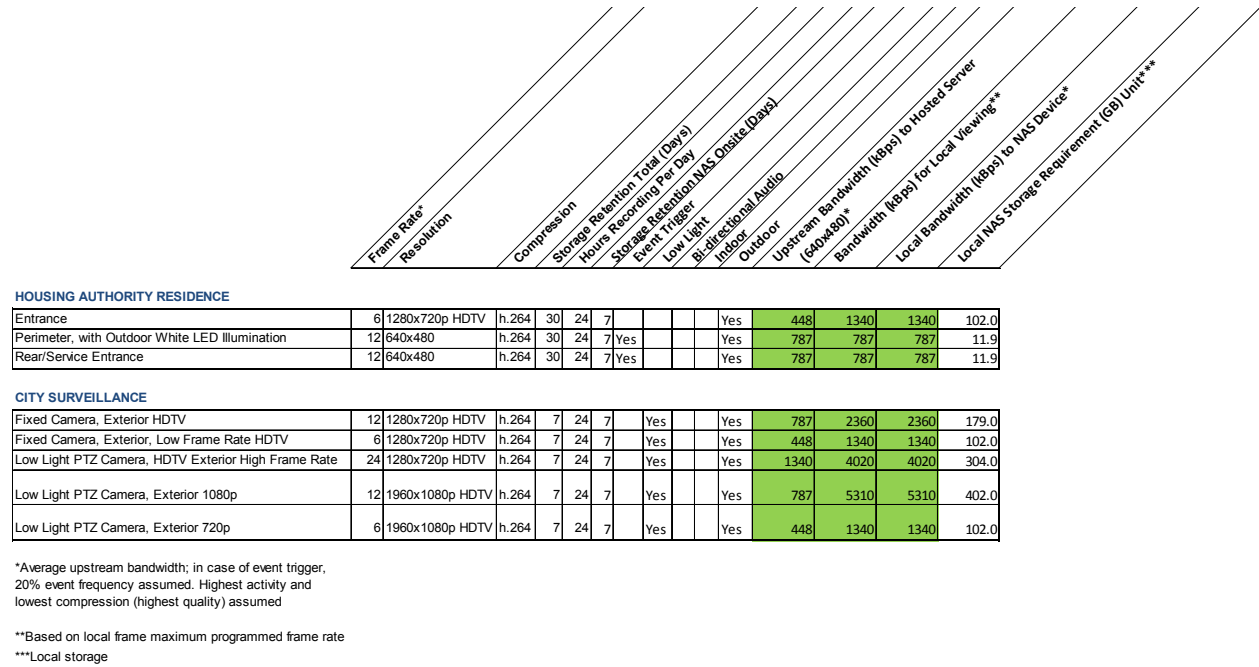

Figure 28: Bandwidth Estimates, Public Safety

## 6.17 Video Analytics/Content Analysis

Applications that use video analytics can perform complex repetitive functions like object detection and recognition on many channels of video simultaneously. Designers consider this where:

- The system uses a large quantity of cameras that require monitoring for specific conditions or behaviors that are capable of being recognized.
- The setup and installation of the video analytics subsystem is relatively simple and has high, sustained accuracy for the types of behaviors and objects recognized.

With video synopsis or summarization, a condensed clip of all motion for selected criteria is continuously generated and stored, allowing an “instant review” of a readily available “video synopsis.” It is possible to summarize a 24-hour period of event entries in as little as 15 minutes, reducing incident review time by at least 50 percent.

Video analytics offering abnormal scene detection allows the user to set specific object criteria and direction. The scene is analyzed continuously and abnormal behavior differing from the majority of the scene content is detected and annunciated or marked for later review.

Video analytics embedded in the network camera represent a growing segment where applications run and values or decisions based on recognition are available with the “edge” network camera and minimal software.

One popular example in retail and quick-service establishments is the “people counter” where the network camera and built-in app return the number of people passing into a zone, through a boundary, or into the field of view.

Another popular video recognition solution that either runs as an embedded network camera application or in the VMS is fixed LPR/LPC. This specialized app captures license plate information for immediate processing by LPR software. The software may run in a rapid acquisition mode and compare plates later against an approved list or perform the recognition sequentially as the vehicles pass within the camera field of view. In either case, LPR is a mature application embraced by law enforcement, electronic toll collection, and parking management organizations; the trend to embed this function reduces cost and allows for greater flexibility.

“Heat” activity mapping provides real-time images showing how people have moved in the camera scene for a fixed duration. Useful in retail environments where “business intelligence” data is needed, this type of video content analysis can improve safety by analyzing the flow of pedestrian and vehicular traffic flow in a facility.

Another available video analytic algorithm, flame and smoke detection analytics, can serve as accurate indoor secondary detection, permitting safety personnel early notification and the opportunity to investigate potential fires.

## 6.18 Video Mobility

The now mature culture of bring your own device (BYOD) has enabled substantial growth of the smartphone. The Nielsen Company reports that smartphones account for two-thirds of their sales, with Android's share of the mobile-software market rising to 51.8 percent in the second quarter 2012, compared with 48.5 percent in the previous period. The great number of mobile applications available for the physical security industry has prompted many solution providers to adopt a consumer-like delivery method of an app store.

The massive adoption of smartphones, BYOD policies, and security mobility apps is bringing security information and situational awareness virtually everywhere. NFC is enabling secure transmissions from device to device, simplifying the credential process. The mobile access control pilot at Arizona State University was the first to validate the use of digital credentials on NFC smartphones for physical access control on a college campus. It essentially puts a smartcard on an NFC-equipped smartphone.

Video mobility is used in every surveillance segment—from small edge systems to managed video services. The bandwidth requirements for video mobility do not necessarily need to be as high as large format displays. The video refresh or display rate in fps or images per second should be matched for the mobile device’s display size. Mobile devices with a smaller display resolution require a lower minimum frame rate and resolution for a given surveillance function; larger displays require a higher frame rate; see figure 29.

With the expanding video communications market, applications supporting adaptive bit rate will automatically optimize video content delivery and often “smart transcode” the video stream. HDTV network cameras do not need to stream their full native resolution to mobile devices; the video stream received by the mobile device may be 10 to 20 percent of the camera’s streaming capacity.

| MOBILE DEVICE RESOLUTIONS, FRAME RATE and BITRATE |                           |                                |                              |                                |              |                 |   |  |   |   |  |           |
|---|---------------------------|--------------------------------|------------------------------|--------------------------------|--------------|-----------------|---|--|---|---|--|-----------|
| Device Type                                       | Make/ Model               | Horizontal Resolution (pixels) | Vertical Resolution (pixels) | Screen Size (diagonal, inches) | Resolution   | Pixels Per Inch | Estimated Mobile Device Bitrate (Note 1)                            |  |   |   | Approx. Mobile Device or Display Viewing Distance (in) | Notes     |
|   |                           |                                |                              |                                |              |                 | Bitrate (kbps) Low Motion Factor (motion factor=1) 5 fps frame rate | Bitrate (kbps) Low Motion Factor (motion factor=1) 10 fps frame rate | Bitrate (kbps) Medium Motion Factor (motion factor=2.5) 15 fps frame rate | Bitrate (kbps) High Motion Factor (motion factor=4) 24 fps frame rate |  |           |
| Smartphone  | Motorola Android          | 960                            | 540                          | 4                              | Custom (qHD) | 275             | 182   | 363  | 1361  | 3484  | 12   | Avg usage |
| Smartphone  | RIM BlackBerry Curve 9220 | 320                            | 240                          | 2.44                           | Custom       | 164             | 27  | 54   | 202   | 517   | 12   | Avg usage |
| Smartphone  | Nokia 900                 | 800                            | 480                          | 4.3                            | WVGA         | 217             | 135   | 269  | 1008  | 2581  | 12   | Avg usage |
| Smartphone  | Apple iPhone 4S           | 960                            | 640                          | 3.5                            | Custom       | 326             | 216   | 431  | 1613  | 4129  | 12   | Avg usage |
| Tablet  | Samsung Galaxy S3         | 1280                           | 720                          | 4.8                            | HDTV 720p    | 306             | 323   | 646  | 2420  | 6194  | 12   | Avg usage |
| Tablet  | Apple iPad                | 2048                           | 1536                         | 9.7                            | Custom       | 264             | 1102  | 2203   | 8258  | 21140   | 14   | Avg usage |
| Ruggedized Tablet                                 | Latitude XT2 XFR          | 1280                           | 800                          | 12.1                           | WXGA         | 125             | 359   | 717  | 2688  | 6882  | 14   | 40° FOV   |
| Ruggedized Laptop                                 | Panasonic Toughbook 31    | 1024                           | 768                          | 13.3                           | XGA          | 96              | 276   | 551  | 2065  | 5285  | 18   | 40° FOV   |
| Ruggedized Laptop                                 | Dell Latitude E6400       | 1280                           | 800                          | 14.1                           | WXGA         | 107             | 359   | 717  | 2688  | 6882  | 18   | 40° FOV   |

Note 1: based on "Kush guage"; "h.264 for the rest of us", Kush Amerasinghe, Adobe Systems

Figure 29: Mobile Device Resolutions and Frame Rate

### HDTV and Mobile Surveillance Video Usage

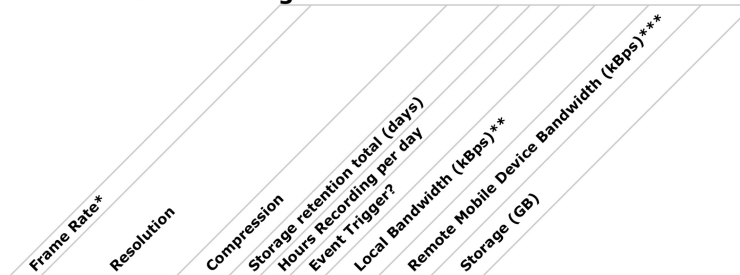

#### PROPERTY MANAGEMENT

|                                     |    |               |       |    |    |     |      |     |      |
|-------------------------------------|----|---------------|-------|----|----|-----|------|-----|------|
| Entry                               | 12 | 1280x720HDTV  | h.264 | 14 | 18 |     | 1390 | 263 | 15.9 |
| Rear/Delivery Door                  | 12 | 1920x1080HDTV | h.264 | 14 | 24 | Yes | 3130 | 263 | 94.5 |
| General Surveillance                | 12 | 1280x720HDTV  | h.264 | 14 | 18 |     | 1390 | 263 | 15.9 |
| Server Room, High Value Storage**** | 12 | 1920x1080HDTV | h.264 | 14 | 24 | Yes | 3130 | 263 | 47.3 |

#### SMALL / MID-SIZE RETAIL

|                                    |    |               |       |    |    |     |      |     |       |
|------------------------------------|----|---------------|-------|----|----|-----|------|-----|-------|
| Entry with Public View Monitor     | 12 | 1280x720HDTV  | h.264 | 30 | 18 |     | 1390 | 263 | 338.0 |
| High Value Room/Locker****         | 12 | 1280x720HDTV  | h.264 | 30 | 24 | Yes | 1390 | 263 | 45.0  |
| Cash Vault/Records/Server Room**** | 12 | 1920x1080HDTV | h.264 | 30 | 24 | Yes | 3130 | 263 | 101.0 |
| Delivery Entrance, Low light       | 12 | 704x480       | h.264 | 30 | 18 | Yes | 471  | 263 | 114.0 |

#### CAMPUS

|                                   |    |               |       |    |    |     |      |     |       |
|-----------------------------------|----|---------------|-------|----|----|-----|------|-----|-------|
| Fixed Camera, Interior            | 12 | 1280x720HDTV  | h.264 | 14 | 24 |     | 1390 | 263 | 210.0 |
| Fixed Camera, Exterior, Low light | 12 | 704x480       | h.264 | 14 | 24 | Yes | 471  | 263 | 7.1   |
| General Surveillance              | 6  | 1920x1080HDTV | h.264 | 14 | 24 |     | 1780 | 263 | 269.0 |

\*Average upstream Bandwidth; in case of event trigger, 20% event frequency assumed. Highest activity and lowest compression (highest quality) assumed  
 \*\*Resolution as noted; highest image quality; maximum motion activity  
 \*\*\*320x240 resolution; maximum motion activity  
 \*\*\*\*10% Activity assumed

Figure 30: HDTV and Mobile Surveillance Bandwidth



The user's vision impacts the perceived image quality as well as the required viewing distance of mobile devices. It's no accident that Apple's "retina" display can deliver images perceived as high quality. With its 326 pixels per inch (PPI) display, the iPhone 4S has a pixel density 14 percent better than the 286 ppi required to deliver a resolution compatible with a 20/20 visual acuity from a distance of one foot.

As the user's vision is impaired, the required distance for maximum visible PPI decreases (see figure 31).

| <b>Maximum visible PPI related to viewing distance (inch)</b>               |                                |           |           |           |           |
|---|--------------------------------|-----------|-----------|-----------|-----------|
| <b>Eyesight<br/>(visus)</b>   | <b>Viewing distance (inch)</b> |           |           |           |           |
|   | <b>12</b>                      | <b>16</b> | <b>24</b> | <b>32</b> | <b>36</b> |
| <b>0.7<br/>[impaired<br/>vision limit]</b>                                  | 210                            | 160       | 105       | 80        | 70        |
| <b>1 [20/20]</b>  | 300                            | 230       | 150       | 115       | 100       |
| <b>1.3 [20/15]</b>  | 390                            | 300       | 195       | 150       | 130       |
| Most common scenario  |                                |           |           |           |           |
| For the purposes of this guide, Dots per Inch (DPI) = Pixels per Inch (PPI) |                                |           |           |           |           |
| 3.5" 960x640 screen size @326dpi  |                                |           |           |           |           |

**Figure 31: Vision and PPI**

## 7. Glossary

The following is a glossary of commonly used terms in specifying the video surveillance system (VSS).

**1080i:** High-definition television (HDTV) format of 1080 interlaced visible lines of 1920 total pixels each in 16:9 aspect ratio. 1080i is per frame (540 lines x two fields) at 30 frames per second (fps), and the high-definition (HD) format is commonly used since 1998. See DTV.

**1080p:** An HDTV format of 1080 progressive visible lines of 1920 total pixels each in 16:9 aspect ratio. 1080p is per frame at either 24 fps or 30 fps. 1080p/60 fps is not one of the 18 Advanced Television Systems Committee (ATSC) formats but new displays introduced since 2005 are able to display in that format. 1080p/24 fps should be ideal for the transfer and broadcast of 24 fps film-based material, but it is not used in present broadcasting. However, should it be used, objectionable flicker would require the 1080p/24 fps to be converted to either progressive 1080p/60 fps or interlaced 1080i/30 fps (60 fields per second).

- If the signal were to be converted to the higher 1080p/60 fps, it would also require a **Cathode Ray Tube** (CRT)-based video projector with a fast raster (67.5 kilohertz [kHz], double the 33.75 kHz of 1080i/30 fps) to be able to synchronize to the signal and display it as 60 fps. The same (fast raster) requirement would apply if the 1080p/60 fps were obtained from line doubling a 1080i/30 fps broadcast program using a scaler/line doubler processor. Some fixed pixel displays released on the first generation(s) of 1080p HDTVs capable of displaying 1080x1920 are not actually able to “accept” a 1080p/60 fps signal from an external source. In 2006, such a source was introduced: Blu-ray HD DVD.

**1080p/24:** An abbreviation referring to video content with resolution, displayed at a frame rate of 24 fps. This is the standard frame rate for film-based content; the vast majority of Blu-ray movies are encoded in 1080p/24. Most HDTVs display images at 60 fps, so only televisions (TVs) capable of displaying frames in multiples of 24 (such as 120 Hz or 240 hertz [Hz] HDTVs) can properly display 1080p/24.

**1080p/60:** An abbreviation referring to video content with 1080p resolution, displayed at a frame rate of 60 fps. While virtually no video content is created in the 1080p/60 format, Blu-ray players often convert Blu-ray movies to 1080p/60 by default because HDTVs do not properly handle 1080p/24.

**3D TV:** A TV that employs techniques of three-dimensional presentation, such as stereoscopic capture, multi-view capture (or 2D plus depth), and a 3D display—a special viewing device to project a television program into a realistic three-dimensional field and delivers it in HDTV format.

**480i:** A standard-definition television (SDTV) format of 480 interlaced visible lines of 704 total pixels each (in 16:9 or 4:3 aspect ratio), or of 640 total pixels each (in 4:3 aspect ratio). 480i is per frame (240 lines x two fields) at 30 fps. 480i/30 fps is similar to interlaced digital versatile disc (DVD) quality. Comparatively, **National Television System Committee** (NTSC) color television is also 480i visible lines but is analog in a 4:3 aspect ratio with 450 pixels edge to edge (also measured as 340 television lines (TVL) lines of horizontal resolution per picture height).

**480p:** An enhanced TV (EDTV) format of 480 progressive visible lines of 704 total pixels each (in 16:9 or 4:3 aspect ratio), or of 640 total pixels each (in 4:3 aspect ratio). 480p is per frame at 24, 30, or 60 fps. The 480p/60 fps format is

similar, but in theory it should be better than progressive DVD quality because the DVD progressive is the result of re-interleaving/line-doubling 480i/30 fps stored DVD images, not 480p/60 fps as EDTV, which should have better temporal resolution suitable for fast action content (like 720p is). This format was originally a standard definition (SD) format; in late 2000, the Consumer Electronics Association (CEA) promoted it to an EDTV level created for 480p.

**720p:** An HDTV format of 720 progressive visible lines of 1280 total pixels each in 16:9 aspect ratio. 720p is per frame at 24, 30, or 60 fps. ABC and ESPN are broadcasting in 720p/60 fps. 720p is considered a better format for fast-action images like sports due to higher temporal resolution than the other commonly used HDTV format (interlaced 1080i).

- The higher temporal resolution of 720p allows the format to complete an image frame in 1/60 of a second while 1080i is only drawing 540 lines with half of the information of the frame of the format. On the next 1/60 of a second, the 720p could record complete detail of a different fast-moving image, while the 1080i would be registering picture information of only the second set of 540 lines containing only half of an image that could also have moved fast enough to produce interlace artifacts when putting the two fields together.

**Accessory:** Any manufacturer-offered device or software that is not part of the base component that may be used with the system.

**Accuracy:** How close a measured value is to the true value or an established standard.

**Active Storage:** A storage location or device (i.e., network video record, server, or virtual [cloud] storage) where digital video, digital multimedia content, or digital multimedia evidence (DME) is originally stored.

**Archival Storage:** A storage location or device to which DME is moved after a designated amount of time and where it resides for an extended period of time.

**Aspect Ratio:** The ratio between the width and height of the video image. A standard NTSC television has a 4:3 (1.33:1) aspect ratio, which is similar to the Academy standard for films before the 1950s (i.e., almost a square box shape). Widescreen screens are rectangular with a 16:9 aspect ratio (1.78:1); some widescreen display panels are only 15:9.

- Several types of widescreen sets are available, including front projection, rear projection, direct-view TVs, LCD TVs, and plasma TVs. Some film aspect ratios are 1.85:1, anamorphic scope 2.35:1 or 2.40:1, and 65 millimeter (mm) (70 mm) from 2.05:1 to 2.21:1. Images from those wider aspect ratios are fitted within the 16:9 (1.78:1) HDTV image as a wider rectangle with top/bottom black bars (that use some vertical resolution lines of the 1080i or 480p DVD).

**Black Level:** Also known as brightness. The level of light produced on a video screen when it emits no light at all (screen black); the NTSC system places the absolute black level at +7.5 IRE (unit of video defined by the Institute of Radio Engineers), a level that is higher than when the television was black and white, which set the absolute black level as zero volts DC. The level was raised because black-and-white transmitters at that time could not handle a color signal with black level at zero volts.

**Chroma:** Sometimes called hue. The term used to characterize color information, such as hue and saturation (not black, gray, and white). Interference of chroma can be seen as rainbow images and color transition dots, which are caused by the interaction between the chrominance and luminance components of a composite video signal.

**Codec:** A device/program capable of encoding and/or decoding digital data. Codecs encode a stream or signal for transmission, storage, or encryption and decode it for viewing and listening.

**Color Temperature:** Characterization of a light source in terms of the temperature of a theoretical black-body radiator that would have a color (spectral energy density) that most closely resembles that of the illuminating source.

- The correct color temperature of a video display should be 6500 degrees Kelvin and express the color quality of a light source. The light source is bluer when the Kelvin measurement is high and reddish when it is low.

**Compliant:** The condition of a device or system model meeting or exceeding all applicable requirements of this handbook and references.

**Component:** Any part or subassembly of devices used in construction of the VSS.

**Component Video:** Analog component video connections used typically for DVD players/recorders, HD-STB/PVRs, audio/video receivers, video switchers, D-VHS VCRs, and HDTVs are:

- a) 3-wire 75 ohm coax analog YPbPr (YCbCr is “digital” component video, and the nomenclature has been incorrectly used abroad for analog connections in consumer equipment); and
- b) 5-wire RGB BNC or VGA 15 pin D-sub with the horizontal and vertical sync signals separated from the other three signals. Component video connections do not carry audio, for which separate audio connectors are required, such as digital coaxial and optical (Toslink). Component video offers higher quality performance than composite and even S-video; it also bypasses the composite en/decoding process and color carrier frequency.

**Composite Video:** An NTSC standard video connection (typically a yellow jack/plug) for the passage of an interlaced video signal that has luminance (black-and-white information), chrominance (color), sync (horizontal and vertical), blanking, and color burst signals, all in one wire. The standard has been used also in VHS and laser disc equipment.

**Compression:** The reduction of data used to represent digital multimedia content (DMC).

**Data File:** A set of digital information representing DMC stored as a single container.

**Date/Time Stamping:** A software feature that automatically inserts the current date/time into the data file.

**Default Settings:** Controls and settings established by the manufacturer prior to delivery of the VSS (e.g., factory settings).

**Definition:** Fidelity of the reproduction of a video picture, affected by resolution.

**Device:** Individual component groups or a division of the VSS.

**Digital Image:** A self-contained frame that is represented by pixels organized in a two-dimensional array, also an I-Frame in a digital or Internet Protocol (IP) video stream.

**Digital Multimedia Content (DMC):** Also known as digital video, IP video content, or DME. Digital data representing audio content, video content, metadata information, location-based information, relevant IP addresses, recording time, system time, and any other information attached to a digital file. DMC may be compressed or uncompressed and may also be referred to as original, copied, local, or virtual.

**Digital Video Recorder (DVR):** Any device that is used to record DMC. The DVR is commonly associated with analog video sources in the physical security industry. The consumer electronics industry refers to the DVR as storage of DMC, delivered via a wide-area network (WAN) and a device that accepts DMC streaming content while providing both analog and digital decoding for display devices.

**Display:** Video and graphics information generated by the computer through the [video card](#).

**DMC (Compressed):** Data that has been transcoded from the original DMC in an industry standard file format, resulting in a reduced amount of data required to represent the original data set.

**DMC (Original):** Data recorded and retrieved to DMC media in its native file format (i.e., first usable form).

**DMC (Uncompressed):** A copy of the original DMC with no further compression or loss of information that is in an industry standard file format.

**Download:** The process of receiving data from another digital source. In the case of the location where a VSS is installed, this is the transfer of IP-based data from another digital source, such as a directly connected server or virtual Internet-based [cloud] servers. The download bit rate is optimized for an asymmetric Internet connection.

**DTV (Digital Television):** The DTV standard is composed of 18 digital formats grouped into two levels of quality, as approved by the ATSC in 1995:

1) SD: Standard definition, 480i/p visible vertical resolution lines with up to 704 total pixels of horizontal resolution, aspect ratio in 4x3 or widescreen 16x9; and

2) HD: High definition, 720p and 1080i/p visible vertical resolution lines with, respectively, 1280 and 1920 total pixels of horizontal resolution in widescreen 16x9 aspect ratio.

- The Federal Communications Commission (FCC) lets manufacturers implement compatible DTV tuners with the ability to receive/decode the formats without imposing TVs to display the formats at their original resolutions; the tuners generally convert the signals to 480p, 720p, and 1080i to match the native format of most monitors. Later in 2000, the CEA created another level in between SD and HD: ED (enhanced), which promoted the 480p format from SD to ED, among other changes (see 810i).
- The current NTSC over-the-air (OTA) TV system is 480i analog (actually, 525i with 480i visible lines) and interlaced. Digital satellite and digital cable are equivalent to digital SD but they are also transmitting some channels in HD. To facilitate the transition, broadcasters were given one extra channel slot from the FCC for the simultaneous broadcasting of the analog and digital versions of their programming.
- It is a large investment for stations to build a DTV facility with new cameras, equipment, etc. When DTV is fully implemented, broadcasters have to return one of the two channels; analog OTA broadcasting will stop; and current TVs, VCRs, Tivos, and any other equipment with analog tuners will stop tuning as well.

- The DTV system implementation is mandatory; HDTV is optional. The implementation of DTV was originally planned by 2007, but the deadline has been conditioned to when 85 percent of the U.S. population can receive DTV signals; discussions were held in 2004 to determine if cable and satellite subscribers should be considered as part of the 85 percent; cable itself covers about 70 percent of the U.S. population.
- On February 1, 2006, an extension to the deadline was approved; the new date for the discontinuation of analog transmissions was February 17, 2009, and the deadline was not conditioned to a percent of DTV reception by households per market as originally; it was a hard date.

**DVI (Digital Visual Interface):** A digital interface specification created by an industry consortium, the Digital Display Working Group. This universal standard for connecting flat-panel monitors is also used for data projectors, plasma displays, and digital TVs. Using a DVI connector and port, a digital signal sent to an analog device is converted into an analog signal; if the device is digital, such as a flat-panel monitor, no conversion is necessary. There are three different DVI configurations: DVI-A for analog signals, DVI-D for digital signals, and DVI-I (integrated) for both analog and digital signals.

- The DVI 1.0 specification was introduced in April 1999 by the Digital Display Working Group and integrated by Silicon Image, Intel, Compaq, Fujitsu, Hewlett-Packard, IBM, and NEC Corporation to create a digital connection interface between a personal computer (PC) and a display device. It is a connection with enough bandwidth for uncompressed HD signals.
- The 1.0 DVI specification is a point-to-point solution that supports video content but not audio. DVI standard cables typically have a five-meter distance limitation, although with better quality wiring, such as fiber-optic, higher distances are possible.
- There are three types of DVI connectors:
  - DVI-A (analog) is available for legacy analog applications to carry analog signals to a CRT monitor or an analog HDTV (claims to be better than VGA).
  - DVI-D (digital) carries digital-only video data to a display.
  - DVI-I (integrated), carries a single- or dual-link digital signal with an additional analog signal for legacy devices.
- DVI is being used as a secure connector for the passage of uncompressed digital video signals from HDTV receivers and other digital source devices, such as DVD players, keeping all signals in the digital domain.
- DVI (or High-Definition Multimedia Interface [HDMI], its upgraded sibling) is found on most HD equipment and HDTVs from 2004 or later. To protect content transmitted over DVI, the High-bandwidth Digital Content Protection (HDCP) scheme was created; HDCP provides a secure digital link between source and display and does not allow for any recording of the digital signal.

**Dynamic Range:** Also known as modulation. The ratio of the highest brightness portions of interest in a digital image to the lowest brightness portions of interest.

**Fidelity:** Accuracy, as compared with a known standard.

**Field of View (FOV):** The horizontal angular extent of a scene viewed by the video camera. The FOV depends on the focal length of the camera lens and the size of the camera's imager.

**Forensic Review:** The act of applying forensic video technology to DMC. Tasks include, but are not limited to: performing digitizing, playback, and analysis of DMC; applying a scientific methodology of forensic video analysis to DMC; using DMC evidence in the legal setting; performing DMC recovery as needed; performing forensic image comparison; developing a visual presentation of evidence; verifying authentication of analog and DMC; detecting tampering; maintaining the chain of custody for DMC evidence as specified under Law Enforcement and Emergency Services Video Association “Guidelines for the Best Practice in the Forensic Analysis of Video Evidence;” and applying an understanding of the effect of light on images.

**Frame Size:** Frame size is defined as the number of horizontal pixels times the number of vertical pixels (e.g., 1280 × 720 or 1920 × 1080). The number of horizontal pixels is often omitted, since it is implied in the context. Therefore, the different systems are usually referred to as 720 or 1080, combined with the letter I or P depending on which scanning method is used.

**HDTV (High-Definition Television):** High-definition television (or HDTV, or just HD) refers to video having resolution substantially higher than traditional television systems (standard-definition TV, or SDTV, or SD). HD has one or two million pixels per frame, roughly five times that of SD.

- HDTV provides up to five times higher resolution than standard analog TV. HDTV has better color fidelity and a 16:9 format. The two most important HDTV standards today are SMPTE 296M and SMPTE 274M, which are defined by the Society of Motion Picture and Television Engineers, or SMPTE.
- HDTV broadcast systems are identified with three major parameters:
  - “Frame size in pixels” is defined as number of horizontal pixels × number of vertical pixels; for example, 1280 × 720 or 1920 × 1080. Often, the number of horizontal pixels is implied from context and is omitted.
  - “Scanning system” is identified with the letter P for progressive scanning or I for interlaced scanning.
  - “Frame rate” is identified as the number of video fps. For interlaced systems, an alternative form of specifying the number of fields per second is often used.
- If all three parameters are used, they are specified in the following form: [frame size][scanning system][frame or field rate] or [frame size]/[frame or field rate][scanning system].

**Interoperability (Communication):** The ability for components in the VSS to recognize devices; establish communications; and share, transmit, store, retrieve, or display DMC.

**Interoperability (Content):** The sharing of DMC among various systems in an industry standard file format.

**IP (Internet Protocol):** A method of transmitting, storing, and displaying DMC.

**Luminance:** The part of a video signal relating to the degree of brightness at any given point in the video image. A video signal is comprised of luminance and chrominance (color information). If luminance is high, the picture is bright and if low, the picture is dark. Changing the chrominance does not affect the brightness of the picture.

**Metadata:** Data embedded within or associated with a file that describes information about or related to the file or directory. This may include, but is not limited to: color, size, trajectory, the locations where the content is stored, dates, times, application-specific information, and permissions.

**Network Disk Recorder:** Also known as network video recorder. This device usually has an embedded operating system and is dedicated to decoding multiple video streams, recording these video streams onto its internal or external hard disk drive media, and streaming either live or recorded video for display on remote PCs or workstations. The device may have direct attached storage.

**Network Topology:** A graphical representation of the arrangement of a network.

**Network Video Camera:** This is a device that produces a video image and encodes it for streaming over a network. This device combines a lens, imager, digital signal processor, and digital/analog converter in a single package. The network video camera will, at a minimum, include an Ethernet connection for the network.

- If this is a remotely positionable camera with pan/tilt motion and zoom lens capability, the camera's position is controlled via commands sent from a user's computer or network recording/control command center directly to the camera over the network. In addition, the network pan/tilt/zoom camera may have an input/output and/or serial connector for an additional means of positioning control.
- If the device is IEEE 802.3af compliant, the power is sent over the Ethernet cable; otherwise, the low-voltage (usually 12 VDC or 24 VAC or both) connections are used for power.

**Network Video Recorder (NVR):** Any device that is used to record digital DMC transmitted via IP. A type of DVR, the NVR is commonly associated with digital video sources that stream IP video.

**Network Video Recording Server:** This device usually has a distributable operating system (e.g., Windows XP, Windows Server) and is dedicated to decoding multiple video streams, recording these video streams onto its internal or external hard disk drive media, and streaming either live or recorded video for display on remote PCs or workstations. The device may have direct attached storage of variable capacity. Video recording servers require an operating system, disk software, and file maintenance by the user.

**Non-Removable Recording Media:** Any data storage that is housed within a device and cannot be removed from that device without disassembly of the device. This is the storage component of the device.

**Observation:** The function of detecting changes in scene, as presented by DMC.

**Pixel:** A picture element.

**Proprietary:** A characteristic of a technique, technology, or device that is owned and controlled by a company or other party and is thereby only usable or adaptable as allowed by that party and not deemed to achieve interoperability.

**Record:** The process of writing DMC to recording media.

**Recording Media:** Any device or component to which DMC is written, stored, and can be retrieved.



**Reliability:** The extent to which a process can repeatedly produce the same effective output, with a central tendency and an acceptable dispersion, for consistent input settings. Information from such a system is said to be reliable.

**Removable Recording Media:** Any portable data storage device designed for removal from a system without disassembly of the system or the storage device.

**Total Cost of Ownership (TCO):** An assessment of the total purchase requirement of goods, deliverables, components, services, labor, and jurisdiction certification.

**Transcoding:** The conversion of DMC from one data file format to another.

**Use Case:** The answers to the following questions define a use case: What is the desired task to be accomplished from viewing that scene? What is in the scene of interest or scene content? The VSS must present a scene of interest to a user in sufficient detail to make a decision or perform a task based on recognition of what is happening in the scene. For example, the end user must be able to read the characters in a license plate or determine the identities of individuals at a local convenience store while performing surveillance.

**Verification:** The process of confirming the accuracy of any version or copy of DMC compared to the original DMC.

**Video Decoder:** This device decodes video streams for direct connection to a composite analog monitor, digital video interface (via DVI or HDMI), or for direct display within a software application. This device is usually located at the network recording/control command center. It can be a multi-channel device in which each output channel may represent a different incoming video stream.

**Video Encoder:** This device converts video from analog cameras into multiple video streams that may be accepted by the network recording/control command center. It may be a single, 4, 16, or higher density channel device that may be placed near the analog camera or at some distance to accommodate placement in a telecommunications room.

**Video Monitor:** Also known as DMC display. A device for viewing live and recorded video; also known as a Digital Panel in the case of digital information.

**Video over Internet Protocol (IP):** The deployment of video information over a network that conforms to the Open Systems Interconnection layer model. This includes support of cameras and encoders transmitting using various protocols (e.g., **transmission control protocol [TCP]/IP**, **user datagram protocol [UDP]**, and file transfer protocol [FTP]).

- Devices that stream video over IP networks transmit frames and packets of video data to a single location or multiple locations for different purposes. A device like a network video camera or multi-channel video encoder can send a video stream to a single NVR or video decoder location or to multiple locations of the same type of equipment.

**Video Surveillance System (VSS):** A selection of devices in the categories of DMC capture, transmission, control, recording, storage, and display that satisfies one or more use cases.

**Video Quality:** The achievement of DMC source-based video data with sufficient resolution to match a use case requirement.