

Voluntary Product Standard PS 2-10

Performance Standard for Wood-Based Structural-Use Panels

June 2011



U.S. Department of Commerce
Gary Locke, Secretary

National Institute of Standards and Technology
Patrick D. Gallagher, Director

Page left blank on purpose

DEPARTMENT OF COMMERCE (DOC) VOLUNTARY PRODUCT STANDARDS

DOC Voluntary Product Standards are developed under procedures published by the Department of Commerce in Title 15 Code of Federal Regulations Part 10, *Procedures for the Development of Voluntary Product Standards*. The purpose of these standards is to establish nationally recognized requirements for products and to provide all concerned interests with a basis for common understanding of the characteristics of the products. The National Institute of Standards and Technology (NIST) administers the Voluntary Product Standards program on a reimbursable basis.

ROLE OF NIST

The role of NIST in the establishment of a DOC Voluntary Product Standard is to act as an unbiased coordinator in the development of the standard, provide editorial assistance in the preparation of the standard, supply such assistance and review as is required to assure the technical soundness of the standard, and seek satisfactory adjustment of valid points of disagreement. NIST also determines compliance with the criteria of the Department's procedures and publishes the standard as a public document.

Producers, distributors, users, consumers, and other interested groups contribute to the establishment of Voluntary Product Standards. These groups initiate and participate in the development of the standards, provide technical or other counsel as appropriate, promote the use of and support for the standards, and assist in keeping them current with respect to advancing technology and marketing practices.

USE OF VOLUNTARY PRODUCT STANDARDS

The use of DOC Voluntary Product Standards is voluntary. NIST has no regulatory power in the enforcement of their provisions; however, since the standards represent a consensus of all interested groups, their provisions are likely to become established as trade customs. In addition, when a DOC Voluntary Product Standard is made part of a legal document, such as a sales contract or code, compliance with the standard is enforceable.

The benefits derived from a DOC Voluntary Product Standard are in direct proportion to their general recognition and actual use. Producers and distributors whose products meet the requirements of a DOC Voluntary Product Standard may refer to the standard in advertising and on labels to promote greater public understanding for confidence in their products. At times, purchasers may order products conforming to the requirements of a DOC Voluntary Product Standard.

For copies of DOC Voluntary Product Standards or more information concerning the development and use of these standards, contact the Standards Services Division, National Institute of Standards and Technology, 100 Bureau Drive, MS 2150, Gaithersburg, MD 20899-2150; <http://ts.nist.gov/docvps>.

Abstract

This standard covers performance requirements, adhesive bond performance, panel construction and workmanship, dimensions and tolerances, marking, and moisture content of structural-use panels. Structural-use panels include structural plywood, oriented strand board (OSB), other mat-formed panels and composite panels. The standard classifies panels by bond classification, span rating, performance category and grade. It provides test methods, a glossary of trade terms and definitions, and a quality certification program whereby agencies inspect, sample, and test products for conformance to this standard. Information regarding industry practices for reinspection, a qualification flowchart, history of the standard, labeling and environmental attributes are provided in nonmandatory appendices.

Keywords

Adhesive bond classification; certification; construction sheathing; structural-use panel; dimensions and tolerances; marking; moisture content; oriented strand board; OSB; panel construction; performance requirements; span rating; mat-formed panel; performance category; structural plywood; test methods; voluntary standard; waferboard; wood-based panels.

CONTENTS

<u>SECTION</u>	<u>PAGE</u>
1. SCOPE	1
2. TERMINOLOGY.....	1
3. REFERENCE PUBLICATIONS	3
4. CLASSIFICATION.....	4
5. REQUIREMENTS.....	5
6. QUALIFICATION TESTING AND MILL SPECIFICATION.....	13
7. TEST METHODS	19
8. TRADEMARKING AND CERTIFICATION.....	36
9. EFFECTIVE DATE AND IDENTIFICATION.....	37
10. STANDING COMMITTEE	37
APPENDIX A REINSPECTION PRACTICES	38
APPENDIX B QUALIFICATION FLOWCHART	41
APPENDIX C HISTORY OF CHANGES	42
APPENDIX D RECOMMENDED THICKNESS LABELS	45
APPENDIX E LABELING GUIDELINES	46
APPENDIX F WOOD STRUCTURAL PANELS AS GREEN BUILDING MATERIALS	51
APPENDIX G FORMALDEHYDE	53

VOLUNTARY PRODUCT STANDARD PS 2-10

PERFORMANCE STANDARD FOR WOOD-BASED STRUCTURAL-USE PANELS

Effective June 1, 2011

(This standard, initiated by APA – *The Engineered Wood Association*, has been developed under the Procedures for the Development of Voluntary Product Standards for the U.S. Department of Commerce.)

1 SCOPE

- 1.1 This Voluntary Product Standard primarily establishes structural criteria for assessing the acceptability of wood-based structural-use panels for construction sheathing and single-floor applications and provides a basis for common understanding among the producers, distributors, and the users of these products. The standard does not address non-structural issues such as resistance to biological agents. Applications other than construction sheathing and single-floor sheathing may require additional engineering considerations that are not covered by this document.
- 1.2 This Standard covers the performance requirements, adhesive bond performance, panel construction and workmanship, dimensions and tolerances, marking and moisture content of structural-use panels.
- 1.3 This Standard includes test methods to determine compliance and a glossary of trade terms and definitions. A quality certification program is provided whereby qualified testing agencies inspect, sample, and test products for qualification under this Standard. Information regarding industry practices for reinspection is provided in Appendix A. A flowchart depicting the qualification process is provided in Appendix B. Information on the maintenance, history, and current edition of the Standard is provided in Appendix C. Recommended thickness labeling is provided in Appendix D. Information on labeling regulations from NIST Handbook 130 is provided in Appendix E. Information on environmental attributes of structural panels are provided in Appendix F and information on formaldehyde emissions is provided in Appendix G.
- 1.4 This Standard incorporates the International System of Units (SI) as well as customary units of measurement. The values given in SI units are the standard. The values given in parentheses are for information only. In conversion of customary units where exact placement is not an issue, such as nail spacing, approximate conversions to SI units are made to yield more easily recognizable numbers. In critical matters, such as panel thickness, exact conversions to SI units are made. For nominal customary units, actual dimensions in SI units are given.
- 1.5 Advisory notes in this Standard shall not be considered mandatory.

2 TERMINOLOGY

2.1 Composite panel

Any panel containing a combination of veneer and other wood-based material.

2.2 Delamination

For plywood or composite panels, delamination is a visible separation between plies or layers that normally receive adhesive at their interface and are firmly contacted in the pressing operation. Wood characteristics, such as checking, leafing, splitting and broken grain, are not to be construed as delamination.

2.3 Furnish

Wood-based material, such as flakes or strands, including applied resin, wax and other additives, as the primary constituent of mat-formed panels.

2.4 Mat-formed panel

Any wood-based panel which does not contain veneer, consistent with the definition of structural-use panels.

2.5 Mill specification

A document that defines product characteristics which affect (or may affect) the classification (Section 4) and/or the performance of the product relative to the requirements of this Standard. The mill specification is unique to each qualified product of a given grade. The specification is used in the mill quality program as audited under third-party inspection.

2.6 Moisture resistant adhesive

Adhesive capable of bonding structural panels in a manner to satisfy the bond classification requirements of this Standard.

2.7 OSB

An acronym for oriented strand board, a type of mat-formed panel with oriented layers resulting in directional properties.

2.8 Performance Category

A panel designation related to the panel thickness range that is linked to the nominal panel thickness designations used in the International Building Code (IBC) and International Residential Code (IRC). For purposes of labeling, as defined in Section 5.2.1.2, abbreviations PERF CAT, CAT or Category are permitted.

2.9 Performance standard

A standard for trademarked products based on performance. Performance is measured by tests that approximate intended end-use conditions.

2.10 Plywood

A conventional all-veneer panel with alternate layers of veneer running perpendicular to one another. For all-veneer panels, a layer is a single veneer ply or two or more adjacent plies with grain direction parallel.

2.11 PS 1

Voluntary Product Standard PS 1-09 "Structural Plywood." Later issues of Voluntary Product Standard PS 1 shall be permitted providing the requirements are applicable and consistent with the issue designated.

2.12 Reference value

The numerical value established for the mill specification for a given mechanical or physical property.

2.13 Sample

A set of specimens analyzed together.

2.14 Sample average

The average test value, obtained by summing the observations and dividing by the number of tests.

2.15 Sample standard deviation

A measure of test variation. Calculated as:

$$S = \sqrt{\frac{\sum x^2 - \frac{(\sum x)^2}{n}}{n - 1}}$$

where:

S = sample standard deviation

x = test observation

n = number of observations

2.16 Shop-cutting panel

A panel which has been rejected as not conforming to a panel grade because of deficiencies, other than adhesive bond quality, which prevent it from meeting the requirements of this Standard. Such a panel shall be identified with a separate mark as specified in Section 8.3.1.

2.17 Specimen

The individual test piece.

2.18 Strength axis

The axis parallel to the face and back orientation of the flakes or the grain (veneer), which is generally the long panel direction, unless otherwise marked.

2.19 Structural-use panel

A panel product composed primarily of wood which, in its commodity end use, is essentially dependent upon certain mechanical and/or physical properties for successful end-use performance. Such a product carrying the trademark of a qualified inspection and testing agency shall conform to performance requirements of one or more of the end-uses contained herein and, where applicable, approved by one or more national regulatory agencies for single-layer floors or for sheathing with respect to roofs, subfloors, and walls. Such a panel shall be identified in a manner clearly conveying its intended end use. The term “structural panel” is synonymous with this term. The International Building Code and International Residential Code (see Section 3.2) use the term “wood structural panel” to refer to panels that comply with PS 2.

2.20 Test exposure condition

The exposure condition to which a panel is subjected prior to test. The following terms apply to the panel moisture conditioning used during performance testing:

Dry test condition – Panel moisture content is within +/- 3% of the as-shipped moisture content.

Wet test condition – Panel moisture content upon 3 days of one-sided wetting.

Wet/redry test condition – After 3 days of one-sided wetting, the panel is dried until the panel moisture content is within +/- 3% of the as-shipped moisture content.

As-shipped moisture content – The panel moisture content when the panels are shipped from the panel manufacturer’s production facility.

3 REFERENCE PUBLICATIONS

3.1 ASTM standards¹

- E 72-05 Standard Test Methods for Conducting Strength Tests of Panels for Building Construction

¹ Copies of these publications are available from ASTM International, 100 Barr Harbor Drive, PO Box C700, West Conshohocken, PA 19428-2959, www.astm.org.

- E 661-03 Standard Test Method for Performance of Wood and Wood-Based Floor and Roof Sheathing Under Concentrated Static and Impact Loads
- D 1037-06a Standard Test Methods for Evaluating Properties of Wood-Base Fiber and Particle Panel Materials
- D 1761-06 Standard Test Methods for Mechanical Fasteners in Wood
- D 3043-00 (2006) Standard Test Methods for Structural Panels in Flexure
- D 4442-07 Standard Test Methods for Direct Moisture Content Measurement of Wood and Wood-Base Materials
- D 2915-03 Standard Practice for Evaluating Allowable Properties for Grades of Structural Lumber

3.2 Other documents

- Voluntary Product Standard PS 1-09 – Structural Plywood²
- CSA-O325.0-2007 Construction Sheathing³
- International Building Code®. International Code Council. Country Club Hills, IL.
- International Residential Code® for One- and Two-Family Dwellings. International Code Council. Country Club Hills, IL.

4 CLASSIFICATION

4.1 General

The structural-use panels covered by this Standard are specified by bond classification, span rating, performance category and grade.

4.1.1 Bond classification

The bond classification is related to the moisture resistance of the glue bond under intended end-use conditions and does not relate to the physical (erosion, ultraviolet, etc.) or biological (mold, fungal decay, insect, etc.) resistance of the panel.

4.1.1.1 Exterior

A bond classification for structural plywood suitable for repeated wetting and redrying or long-term exposure to weather or other conditions of similar severity.

4.1.1.2 Exposure 1

A bond classification for panels suitable for uses not permanently exposed to the weather. Panels classified as Exposure 1 are intended to resist the effects of moisture on structural performance due to construction delays, or other conditions of similar severity.

4.1.2 Grade

This Standard covers grades of structural-use panels designed and manufactured for sheathing, Structural I sheathing, and single-floor applications.

4.1.2.1 Sheathing

A wood-based structural-use panel intended for use in construction applications as covering material for roofs, subfloors, and walls when fastened to supports spaced in accordance with the span rating.

4.1.2.2 Structural I Sheathing

A wood-based structural-use panel consistent with that described in Section 4.1.2.1, except that Structural I panels meet additional requirements in this Standard for cross-panel strength and stiffness and for racking load performance.

² Copies of the current standard are available from the Superintendent of Documents, U.S. Government Printing Office, Washington, DC 20402 and the Standards Services Division, National Institute of Standards and Technology, 100 Bureau Drive, Stop 2150, Gaithersburg, MD 20899-2150, web site: <http://gsi-i.nist.gov/global/index.cfm/L1-5/L2-44/A-355>.

³ Copies of this publication are available from the Canadian Standards Association, 5060 Spectrum Way, Mississauga, ON, Canada L4W 5N6, www.csa.ca.

4.1.2.3 Single Floor

A wood-based structural-use panel intended for use as combination subfloor and underlayment when fastened to supports spaced in accordance with the span rating.

4.1.3 Span rating

An index number, based on customary inch units, that identifies the recommended maximum center-to-center support spacing for the specified end use under normal use conditions. Spans are defined for end uses such as roof, wall, subfloor, and single floor. As a matter of convention, spans are typically specified singly for wall (Wall 24) and single floor (Floor 24 o.c.), while roof and subfloor are often combined in a fractional format. For example, a span rating of 32/16 designates a roof span of 32 inches and a subfloor span of 16 inches.

4.1.4 Performance Category

A panel designation related to the panel thickness range that is linked to the nominal panel thickness designations used in the International Building Code (IBC) and International Residential Code (IRC). For purposes of labeling, as defined in Section 5.2.1.2, abbreviations PERF CAT, CAT or Category are permitted.

5 REQUIREMENTS

5.1 General

Structural-use panels represented as conforming to this Standard shall meet all applicable requirements set forth herein.

5.2 General Requirements

5.2.1 Dimensional tolerances and squareness of panels

5.2.1.1 Size

A tolerance of plus or minus 1.6 mm (1/16 in.) shall be allowed on manufactured length and/or width.

5.2.1.2 Performance Category and Thickness Tolerance

A tolerance of plus or minus 0.8 mm (for metric basis) or 1/32 in. (for English basis) shall be allowed on the trademark-specified Performance Category of 20.5 mm (13/16 in.) and less, and $\pm 5\%$ of the trademark-specified Performance Category for panels thicker than 20.5 mm (13/16 in.), unless a closer tolerance is determined through qualification testing.

Panel thickness shall be measured with a micrometer having 19.1 mm (3/4 in.) (minus 0, plus 1.3 mm [0.050 in.] diameter anvils. Measurements shall be taken at an applied anvil pressure of not less than 34 kPa (5 psi) or more than 69 kPa (10 psi). The location of the measurements shall be representative of general panel thickness at approximate mid-length along each edge of the panel and the average of the four measurements shall be taken as the thickness of that panel. If a measurement point contains a permissible grade characteristic that affects panel thickness, then the measurement point shall be shifted from that point.

The panel thickness shall conform to Table 1.

TABLE 1. PANEL THICKNESS REQUIREMENTS

PERFORMANCE CATEGORY ²	Thickness Requirements ¹	
	Minimum Thickness, mm (in.)	Maximum Thickness, mm (in.)
1/4 PERF CAT	5.56 (0.219)	7.14 (0.281)
5/16 PERF CAT	7.14 (0.281)	8.73 (0.344)
11/32 PERF CAT	7.94 (0.313)	9.53 (0.375)
3/8 PERF CAT	8.73 (0.344)	10.32 (0.406)
7/16 PERF CAT	10.32 (0.406)	11.91 (0.469)
15/32 PERF CAT	11.11 (0.438)	12.70 (0.500)
1/2 PERF CAT	11.91 (0.469)	13.49 (0.531)
9/16 PERF CAT	13.49 (0.531)	15.08 (0.594)
19/32 PERF CAT	14.29 (0.563)	15.88 (0.625)
5/8 PERF CAT	15.08 (0.594)	16.67 (0.656)
23/32 PERF CAT	17.46 (0.688)	19.05 (0.750)
3/4 PERF CAT	18.26 (0.719)	19.84 (0.781)
13/16 PERF CAT	19.84 (0.781)	21.43 (0.844)
7/8 PERF CAT	21.11 (0.831)	23.34 (0.919)
1 PERF CAT	24.13 (0.950)	26.67 (1.050)
1-1/8 PERF CAT	27.15 (1.069)	30.00 (1.181)
1-1/4 PERF CAT	30.16 (1.188)	33.34 (1.313)

¹Thickness requirements are based on a tolerance of ± 0.8 mm (1/32 in.) for panels with Performance Categories of 13/16 and less and $\pm 5\%$ for panels with Performance Categories greater than 13/16 unless a closer tolerance is determined through qualification testing.

²For labeling purposes, abbreviation of “Performance Category” by PERF CAT, CAT or Category is permitted.

5.2.1.3 Squariness and straightness

Panels shall be square within 1.3 mm per lineal meter (1/64 in. per lineal foot) of the longest edge measured along the diagonals. All panels shall be manufactured so that a straight line drawn from one corner to the adjacent corner is within 1.6 mm (1/16 in.) of the panel edge.

5.2.2 Wood materials

5.2.2.1 Veneer

Any wood veneer used as a component of a panel shall be in accordance with the applicable veneer grade and workmanship requirements of Voluntary Product Standard PS 1.

ADVISORY NOTE: Canadian Standard CAN/CSA-O325.0, which is the Canadian counterpart to PS 2, limits maximum size of knots and knotholes to 76 mm (3 in.) as measured across the grain.

5.2.2.2 Other material

Other materials used in panel manufacture shall include particles or fiber produced by breaking down solid wood.

5.2.3 Design and construction

Panels qualifying for a span rating are identified in three classes: plywood panels, composite panels, or mat-formed panels. See Section 2 for definitions of terms. Panels shall qualify on an individual panel construction basis for the grade and span rating upon demonstrated conformance to the appropriate requirements of Section 5.3.

5.3 Performance requirements

Structural-use panels to be trademarked in accordance with this Standard shall pass performance criteria established in three areas: structural performance, physical properties, and adhesive bond performance. Performance requirements listed in Sections 5.3.1, 5.3.2, and 5.3.3 are for all grades of structural-use panels except where noted otherwise.

5.3.1 Structural performance

Panels shall meet the performance requirements of Sections 5.3.1.1 through 5.3.1.4 when tested for each structural condition in accordance with the referenced test procedure. Section 6 details specimen requirements and additional test set procedures.

5.3.1.1 Concentrated loads

Panels shall be tested according to the procedures of Section 7.1 for concentrated static and impact loads. Panels shall conform to the criteria of Table 2 for the grade and span shown on the trademark.

Panels to be identified as Structural I Sheathing and with a Performance Category of 7/16 or larger shall also be tested according to the procedures of Section 7.1, with the framing members parallel to the strength axis direction, except the load shall be applied at panel mid-length. Minimum test panel size shall be 1,220 x 2,440 mm (48 x 96 in.). The framing shall be spaced 610 mm (24 in.) on center (o.c.). The panel ends shall not be supported by framing. Panels shall conform to the criteria of Table 2 for Roof - 24. See Section 6.2.4.2 for additional testing requirements associated with knots and knotholes.

5.3.1.2 Uniform loads

Panels shall be tested according to the procedures of Section 7.2 for uniform loads. Panels shall conform to the criteria of Table 3 for the grade and span shown on the trademark.

Panels to be identified as Structural I Sheathing shall also be tested according to procedures of Section 7.2 with the framing members parallel to the strength axis direction. Minimum test panel size shall be 1,220 x 1,220 mm (48 x 48 in.). The framing shall be spaced 610 mm (24 in.) o.c. The panel ends shall not be supported by framing. Panels shall conform to the criteria of Table 4.

5.3.1.3 Wall racking

Sheathing panels which are rated for wall span 16 or 24 and for roof span 16, 20 or 24 shall be tested according to the procedures of Section 7.3 for wall racking. Panels shall conform to the criteria of Table 5 for the Performance Category shown on the trademark.

Panels to be identified as Structural I Sheathing shall meet the Structural I Sheathing requirements of Table 5 for the Performance Category shown on the trademark, when tested according to the procedures of Section 7.3.

5.3.1.4 Fastener holding

Panels shall be tested according to the procedures of Section 7.4 for fastener holding under lateral and withdrawal loads. Panels shall conform to the criteria of Table 6 for the grade and Performance Category shown on the trademark.

5.3.2 Physical properties

Panels shall meet the performance requirements of Section 5.3.2.1 for each physical property when tested in accordance with the referenced test method. Section 6.2.3 details specimen requirements and additional test set procedures.

5.3.2.1 Dimensional Stability

Panels shall be tested according to one of the following linear expansion test procedures:

- a. **Exposure to 50% ($\pm 5\%$) relative humidity; 21°C ± 6 °C (70°F ± 10 °F) and vacuum-pressure soak** – Panels shall be tested along and across the strength axis according to the procedures of Section 7.8 for linear expansion from 50% relative humidity to vacuum-pressure soak. The average linear expansion shall be no more than 0.50% as measured according to the test method.
- b. **One-sided wetting and relative humidity** – Panels shall be tested according to the procedures of Section 7.9 for linear expansion and thickness expansion (Single Floor only) as measured by one-sided wetting and Section 7.10 for linear and thickness expansion (Single Floor only) as measured by relative humidity exposures. The free panel linear expansion shall be no more than 0.30% along the panel strength axis and 0.35% across the panel strength axis. Thickness swell of Single Floor shall be no greater than 25%.

Table 2. Concentrated static and impact test performance criteria for panels tested according to Section 7.1. (See Section 6.2.2.1 for pass/fail criteria)

End Use – Span Rating	Test Exposure Conditions ^(a)	Performance Criteria					
		Ultimate Load				Deflection Under 0.89 kN (200 lbf) Load	
		Static		Following Impact ^(b)		Mm	in.
		kN	lbf	kN	lbf		
Roof - 16	Dry Wet	1.78	400	1.33	300	11.1 ^{(c)(d)}	0.438 ^{(c)(d)}
Roof – 20 ^(f)	Dry Wet	1.78	400	1.33	300	11.9 ^{(c)(d)}	0.469 ^{(c)(d)}
Roof - 24	Dry Wet	1.78	400	1.33	300	12.7 ^{(c)(d)}	0.500 ^{(c)(d)}
Roof - 32	Dry Wet	1.78	400	1.33	300	12.7 ^{(c)(d)}	0.500 ^{(c)(d)}
Roof - 40	Dry Wet	1.78	400	1.33	300	12.7 ^{(c)(d)}	0.500 ^{(c)(d)}
Roof - 48	Dry Wet	1.78	400	1.33	300	12.7 ^{(c)(d)}	0.500 ^{(c)(d)}
Roof - 54	Dry Wet	1.78	400	1.33	300	12.7 ^{(c)(d)}	0.500 ^{(c)(d)}
Roof - 60	Dry Wet	1.78	400	1.33	300	12.7 ^{(c)(d)}	0.500 ^{(c)(d)}
Subfloor - 16	Dry Wet/Redry	1.78	400	1.78	400	4.8 ^(c)	0.188 ^(c)
Subfloor - 20 ^(f)	Dry Wet/Redry	1.78	400	1.78	400	5.6 ^(c)	0.219 ^(c)
Subfloor - 24	Dry Wet/Redry	1.78	400	1.78	400	6.4 ^(c)	0.250 ^(c)
Subfloor - 32	Dry Wet/Redry	2.45	550	1.78	400	5.3 ^(c)	0.207 ^(c)
Subfloor - 48	Dry Wet/Redry	2.45	550	1.78	400	8.0 ^(c)	0.313 ^(c)
Single Floor - 16	Dry Wet/Redry	2.45	550	1.78	400	2.0 ^(e)	0.078 ^(e)
Single Floor - 20 ^(f)	Dry Wet/Redry	2.45	550	1.78	400	2.4 ^(e)	0.094 ^(e)
Single Floor - 24	Dry Wet/Redry	2.45	550	1.78	400	2.7 ^(e)	0.108 ^(e)
Single Floor - 32	Dry Wet/Redry	3.11	700	1.78	400	2.2 ^(e)	0.088 ^(e)
Single Floor - 48	Dry Wet/Redry	3.11	700	1.78	400	3.4 ^(e)	0.133 ^(e)

^(a) Wet/redry shall be exposure to three days of continuous wetting, followed by testing dry. Wet conditioning shall be exposure to three days of continuous wetting, then tested wet. Dry shall be within +/- 3% of the as-shipped moisture content.

^(b) Impact shall be 102 N•m (75 lbf•ft) for span ratings up to 24, 122 N•m (90 lbf•ft) for 32, 163 N•m (120 lbf•ft) for 40, and 203 N•m (150 lbf•ft) for 48 and greater.

^(c) Criteria apply under static concentrated load. They do not apply following impact.

^(d) Deflection after wet conditioning not applicable.

^(e) Criteria apply under static concentrated load and following impact.

^(f) The “20” span rating designation is intended for end-use spans of 19.2 inch.

Table 3. Uniform load performance criteria for panels tested according to Section 7.2. (See Section 6.2.2.2 for pass/fail criteria)					
End Use - Span Rating	Test Exposure Conditions^(b)	Performance Criteria			
		Average Deflection Under Load	Ultimate Uniform Load		
			kPa	lbf/ft²	
Wall - 16	Dry	Not applicable		3.6 ^(c)	75 ^(c)
Wall - 24	Dry	Not applicable		3.6 ^(c)	75 ^(c)
Roof - 16 ^(a)	Dry	1.7 mm at 1.68 kPa (0.067 in. at 35 lbf/ft ²)		7.2	150
Roof - 20 ^{(a)(d)}	Dry	2.0 mm at 1.68 kPa (0.080 in. at 35 lbf/ft ²)		7.2	150
Roof - 24 ^(a)	Dry	2.5 mm at 1.68 kPa (0.100 in. at 35 lbf/ft ²)		7.2	150
Roof - 32	Dry	3.4 mm at 1.68 kPa (0.133 in. at 35 lbf/ft ²)		7.2	150
Roof - 40	Dry	4.2 mm at 1.68 kPa (0.167 in. at 35 lbf/ft ²)		7.2	150
Roof - 48	Dry	5.1 mm at 1.68 kPa (0.200 in. at 35 lbf/ft ²)		7.2	150
Roof - 54	Dry	5.7 mm at 1.68 kPa (0.225 in. at 35 lbf/ft ²)		7.2	150
Roof - 60	Dry	6.4 mm at 1.68 kPa (0.250 in. at 35 lbf/ft ²)		7.2	150
Subfloor - 16	Dry Wet/Redry	1.1 mm at 4.79 kPa (0.044 in. at 100 lbf/ft ²)		15.8	330
Subfloor - 20 ^(d)	Dry Wet/Redry	1.3 mm at 4.79 kPa (0.053 in. at 100 lbf/ft ²)		15.8	330
Subfloor - 24	Dry Wet/Redry	1.7 mm at 4.79 kPa (0.067 in. at 100 lbf/ft ²)		15.8	330
Subfloor - 32	Dry Wet/Redry	2.2 mm at 4.79 kPa (0.088 in. at 100 lbf/ft ²)		15.8	330
Subfloor - 48	Dry Wet/Redry	3.4 mm at 3.83 kPa (0.133 in. at 80 lbf/ft ²)		10.8	225
Single Floor - 16	Dry Wet/Redry	1.1 mm at 4.79 kPa (0.044 in. at 100 lbf/ft ²)		15.8	330
Single Floor - 20 ^(d)	Dry Wet/Redry	1.3 mm at 4.79 kPa (0.053 in. at 100 lbf/ft ²)		15.8	330
Single Floor - 24	Dry Wet/Redry	1.7 mm at 4.79 kPa (0.067 in. at 100 lbf/ft ²)		15.8	330
Single Floor - 32	Dry Wet/Redry	2.2 mm at 4.79 kPa (0.088 in. at 100 lbf/ft ²)		15.8	330
Single Floor - 48	Dry Wet/Redry	3.4 mm at 3.83 kPa (0.133 in. at 80 lbf/ft ²)		10.8	225

^(a) Panels with Roof - 16 and Roof - 20 rating shall also meet performance requirements for Wall - 16 rating. Panels with Roof - 24 rating shall also meet requirements for Wall - 24 rating.

^(b) Wet/Redry shall be exposure to three days of continuous wetting, followed by testing dry. Dry shall be within +/- 3% of the as-shipped moisture content.

^(c) The panel strength axis shall be placed along the supports for testing, unless otherwise specified.

^(d) The "20" span rating designation is intended for end-use spans of 19.2 inch.

Table 4. Uniform load performance criteria for Structural I Sheathing panels tested according to Section 7.2. (Also see Section 5.3.1.2 and Section 6.2.2.2 for pass/fail criteria)					
Performance Category	Test Exposure Conditions^(a)	Performance Criteria			
		Average Deflection Under Load	Ultimate Uniform Load		
			kPa	lbf/ft²	
7/16	Dry	2.5 mm at 0.96 kPa (0.100 in. at 20 lbf/ft ²)		4.3	90
15/32	Dry	2.5 mm at 1.68 kPa (0.100 in. at 35 lbf/ft ²)		6.5	135
1/2	Dry	2.5 mm at 1.92 kPa (0.100 in. at 40 lbf/ft ²)		7.2	150
19/32 & 5/8	Dry	2.5 mm at 3.35 kPa (0.100 in. at 70 lbf/ft ²)		11.5	240
23/32 & ¾	Dry	2.5 mm at 4.31 kPa (0.100 in. at 90 lbf/ft ²)		14.4	300

^(a) Dry shall be within +/- 3% of the as-shipped moisture content.

Table 5. Racking load performance criteria for panels tested according to Section 7.3. (See Section 6.2.2.3 for pass/fail criteria)																			
Performance Category	Test Exposure Condition ^(b)	Nail Size (dia. x length)		Nail Spacing				Test Load				Performance Criteria ^(a)							
												Ultimate Load							
				Panel Edge		Inter-mediate Studs ^(c)		Sheathing		Structural I		Deflection @ Test Load		Sheathing		Structural I			
mm	in.	mm	in.	mm	in.	kN/m	lbf/ft	kN/m	lbf/ft	mm	in.	kN/m	lbf/ft	kN/m	lbf/ft				
Less than 5/16	Dry	2.9 x 51	0.113 x 2.0	150	6	300	12	2.2	150	---	---	5.1	0.2	9.5	650	---	---		
								4.4	300	---	---	15.2	0.6						
5/16	Dry	2.9 x 51	0.113 x 2.0	75	3	300	12	5.1	350	---	---	5.1	0.2	14.3	980	---	---		
3/8	Dry	3.3 x 64	0.131 x 2.5	75	3	300	12	6.0	410	6.7	460	5.1	0.2	16.8	1150	18.8	1290		
7/16	Dry	3.3 x 64	0.131 x 2.5	75	3	300	12	6.6	450	7.4	505	5.1	0.2	18.4	1260	20.7	1415		
15/32	Dry	3.8 x 76	0.148 x 3.0	75	3	300	12	8.8	600	9.7	665	5.1	0.2	24.5	1680	27.1	1860		
19/32 and greater	Dry	3.8 x 76	0.148 x 3.0	75	3	300	12	9.7	665	9.7	665	5.1	0.2	27.1	1860	27.1	1860		

^(a) Stud spacing – 405 mm (16 in.) o.c. for Wall-16, Roof-16, and Roof-20; 610 mm (24 in.) o.c. for all other span ratings and all Structural I Sheathing panels.
^(b) Dry shall be within +/- 3% of the as-shipped moisture content.
^(c) For studs spaced 610 mm (24 in.) o.c., nail spacing on intermediate studs shall be 150 mm (6 in.) o.c. for panels with a Performance Category of 7/16 and less.

Table 6. Fastener performance criteria under lateral and withdrawal loads for panels tested according to Section 7.4. (See Section 6.2.2.4 for pass/fail criteria)							Performance Criteria for Ultimate Load ^(c)			
Grade	End Use	Performance Category	Nail Size ^(a) (dia. x length)		Test Exposure Condition ^(b)	Lateral Nail holding		Withdrawal		
			mm	in.		N	lbf	N	lbf	
Sheathing	Wall	Through 1/2	2.9 x 51	0.113 x 2.0	Dry	778	175	(d)	(d)	
		Greater than 1/2	3.3 x 64	0.131 x 2.5	Wet/Redry	600	135	(d)	(d)	
	Roof	Through 1/2	2.9 x 51	0.113 x 2.0	Dry	778	175	89	20	
		Greater than 1/2	3.3 x 64	0.131 x 2.5	Wet/Redry	600	135	67	15	
	Subfloor	Through 1/2	2.9 x 51	0.113 x 2.0	Dry	934	210	89	20	
		Greater than 1/2	3.3 x 64	0.131 x 2.5	Wet/Redry	712	160	67	15	
Single Floor	Floor	Through 1/2	2.9 x 51	0.113 x 2.0	Dry	934	210	89	20	
		Greater than 1/2	3.3 x 64	0.131 x 2.5	Wet/Redry	712	160	67	15	

(a) Common smooth-shank nail.
(b) Wet/redry shall be exposure to three days of continuous wetting, followed by testing dry. Dry shall be within +/- 3% of the as-shipped moisture content.
(c) Tabulated values represent the 10th percentile with 75% confidence from 20 specimens.
(d) Not applicable.

Table 7. Exposure 1 Criteria for OSB Tested Along the Strength Axis According to Section 7.6, Cycled According to Section 7.16 ^a (See Section 6.2.4.1(d) for pass/fail criteria)			
Performance Category	End Use - Span Rating	Bending Capacity (Required Moment)	
		N-mm/mm	lbf-in./ft
3/8	Roof - 24	310	830
7/16	Roof - 24/Subfloor - 16	350	950
15/32 & 1/2	Roof - 32/Subfloor - 16	380	1,030
19/32 & 5/8	Roof - 40/Subfloor - 20	450	1,210
23/32 & 3/4	Roof - 48/Subfloor - 24	640	1,720
9/16	Single Floor - 16	390	1,060
19/32 & 5/8	Single Floor - 20	420	1,130
23/32 & 3/4	Single Floor - 24	610	1,650
7/8 & 1	Single Floor - 32	1,000	2,690
1-1/8	Single Floor - 48	1,140	3,060

^a Bond performance may also be established using procedures defined in Section 6.2.4.1.e.

5.3.3 Bond performance

Panels shall meet the performance requirements of Sections 5.3.3.1 through 5.3.4.3 for properties that affect the adhesive bonding system when tested in accordance with the referenced test method. Section 6.2.4 details specimen requirements and additional test set procedures.

5.3.3.1 Bond classification

Structural-use panels shall meet the bond requirements listed below for their respective exposure bond classification.

- a. **Exterior Plywood** – Plywood rated as Exterior shall meet PS 1 bond requirements for Exterior panels. Exterior delamination in plywood is a visible separation at a single glue line that exceeds 19.4 cm² (3 in.²) in an area coinciding with open knotholes, pitch pockets, splits, gaps and other voids or characteristics permitted in the panel grade.
- b. **Exposure 1 Plywood** – Plywood rated as Exposure 1 shall meet PS 1 bond requirements for Exposure 1. Exposure 1 delamination in plywood is a visible separation in any glue line that exceeds 19.4 cm² (3 in.²) except where directly attributable to characteristics permitted in the grade as follows:
 - Knots and knotholes – not to exceed the size permitted in the grade plus a surrounding band not wider than 19.1 mm (3/4 in.).
 - Other permissible grade characteristics – not to exceed the size permitted in the grade.
- c. **Exposure 1 Composite panels** - Composite panels rated as Exposure 1 shall satisfy the delamination requirements of Section 6.2.4.1.c when tested in accordance with Section 7.13, following moisture cycling according to Section 7.17. Exposure 1 delamination in composites is a visible separation along a test specimen edge and/or end, between veneer-to-veneer or veneer-to-wood-based material glue lines, not to exceed 6.4 mm (1/4 in.) depth for a continuous length of 25 mm (1 in.).
- d. **Exposure 1 OSB** – OSB panels rated as Exposure 1 shall meet or exceed the criteria in Table 7 when tested in accordance with method Section 7.6 following moisture cycling according to Section 7.16 or the procedures of Section 5.3.3.1.e.

ADVISORY NOTE: Values in Table 7 were based on properties from representative industry panels that met requirements for structural performance when tested in accordance with Section 6.2.2.1 and bond performance when tested in accordance with Section 7.7 following moisture cycling according to Section 7.17.

- e. **Exposure 1 mat-formed panels** - Mat-formed panels and wood-based material for composite panels rated as Exposure 1 shall exhibit a minimum average strength retention of 50% with no individual panel retained strength less than 40% when tested in accordance with Section 7.7 following moisture cycling according to Section 7.17.

5.3.3.2 Bond performance associated with knots and knotholes

Structural-use plywood rated as Exposure 1 shall satisfy the requirements of Section 6.3.4.4 when tested in accordance with Sections 7.18 and 7.19.

5.3.4 Adhesive performance

5.3.4.1 Adhesive mold resistance

Panel adhesive bonds shall satisfy the mold resistance test according to the procedures of Section 7.14 as defined in Section 6.2.5.1. Phenolic and isocyanate-based adhesives have demonstrated resistance to attack from mold and shall be considered as meeting this requirement.

5.3.4.2 Adhesive resistance to elevated temperature

Panel adhesive bonds shall be considered to satisfy sufficient elevated-temperature resistance (71°C [160°F]) when they meet the requirements of Section 5.3.3.1.

5.3.4.3 Adhesive bacteria resistance

Panel adhesive bonds shall satisfy the bacteria test according to the procedures of Section 7.15 as defined in Section 6.2.5.3. Phenolic and isocyanate-based adhesives have demonstrated resistance to attack from bacteria and shall be considered as meeting this requirement.

5.4 Moisture content

Moisture content of panels at time of shipment from the manufacturer and at the time of testing shall be less than 16% as determined by Section 7.11.

6 QUALIFICATION TESTING AND MILL SPECIFICATION

6.1 General

This section details test specimen requirements, conformance criteria, additional test set options, and mill specifications. See Appendix B for a flowchart.

6.2 Qualification testing

6.2.1 General

Qualification tests are a function of the panel grade. Required tests and performance criteria are detailed in Section 5. Conformance criteria and additional test set requirements are given by test in this section.

Panels for qualification testing shall be representative of minimum performance.

Tests shall be conducted according to the application specifications of the manufacturer and the use for which the panel is being qualified, at the support spacing to be shown on the trademark. Any special product modification which affects performance (e.g., moisturizing or water repellent treatment) shall be noted per Section 6.3. Upon failure of qualification tests, provisions shall be followed for one additional series of tests provided no change has been made in the manufacturing process. If a product satisfies the provisions of the additional testing, it shall pass the performance qualification test in question. If it does not, the product shall fail the performance qualification test. If a change in panel configuration or processing has been made, additional qualification tests shall be performed when required by the qualified testing agency.

6.2.2 Structural performance

6.2.2.1 Concentrated loads

Test a maximum of 20 specimens taken from at least 10 panels. Ten specimens (taken from at least five panels) for each test exposure condition shall be evaluated for both concentrated static and impact loads according to Section 7.1. Requirements are found in Table 2. If additional tests are needed, they shall also consist of 10 specimens, and the results of the two 10-specimen sets shall be combined. Only one additional test set is allowed. If the combined results meet or exceed the minimum passing rate, the sample passes.

a. Deflection – The initial test set consists of 10 specimens.

- The average deflection shall not be greater than the appropriate requirement in Table 2.
- If no more than one value is above the requirement, the sample passes.
- If two or three values are above the requirement, test an additional set.
- If four or more values are above the requirement, the sample fails.
- If ten additional specimens are tested, the combined passing rate shall be at least 85%.

b. Ultimate load – The initial test set consists of 10 specimens.

- The average load shall not be less than the appropriate requirement in Table 2.
- If all of the values meet or exceed the requirement, the sample passes.
- If one of the values is below the requirement, test an additional set.
- If two or more values are below the requirement, the sample fails.
- If ten additional specimens are tested, the combined passing rate shall be at least 95%.

6.2.2.2 Uniform loads

Test a maximum of 20 specimens taken from at least 10 panels. Ten specimens (taken from at least five panels) for each test exposure condition shall be evaluated for uniform-load capacity according to Section 7.2. Test requirements are found in Table 3 and Table 4 (Structural I). If additional tests are needed, they shall also consist of 10 specimens, and the results of the two 10-specimen sets shall be combined. Only one additional test set is allowed. If the combined results meet or exceed the minimum passing rate, the sample passes.

a. Deflection – The average deflection shall not be greater than that specified. The initial test consists of 10 specimens.

- If the average value is below the requirement, the sample passes.
- If the average value is above the requirement, test an additional set.
- If the average value based on combined results is above the requirement, the sample fails.

b. Ultimate load – The initial test consists of 10 specimens.

- The average load shall not be less than the appropriate requirement in Table 3.
- If all of the values meet or exceed the requirement, the sample passes.
- If one of the values is below the requirement, test an additional set.
- If two or more values are below the requirement, the sample fails.
- If ten additional specimens are tested, the combined passing rate shall be at least 95%.

6.2.2.3 Wall racking

Two wall assemblies shall be evaluated for wall racking according to Section 7.3. Requirements are found in Table 5. If an additional test is needed, it shall consist of one wall assembly, and the results of the three tests shall be combined. Only one additional test is allowed.

a. Deflection – The average deflection shall not be greater than that specified (Table 5). The initial test shall consist of two samples.

- If the average value is below the requirement, the sample passes.
- If the average value is above the requirement, test one additional wall assembly.
- If the average value based on combined results is above the requirement, the wall evaluation fails.

b. Ultimate load – The minimum passing rate shall be 100%. The initial test shall consist of two samples. If only two walls are tested, the ultimate loads shall be within 10% of each other.

- If either of the two test values is below the requirement, the sample fails.
- If the two test values meet the requirement but do not agree within 10%, test one additional wall assembly. The lower of the two test values shall be used to calculate the 10% allowance.
- If the lowest value of the three walls tested exceeds the specified minimum ultimate load, the wall evaluation passes.

6.2.2.4 Fastener holding

Test a maximum of 40 specimens taken from at least 20 panels. Twenty specimens (taken from at least 10 panels) for each test exposure condition and property shall be tested for lateral and withdrawal loads according to Section 7.4. Requirements are found in Table 6. If additional tests are needed, they shall also consist of 20 specimens, and the results of the two 20-specimen sets shall be combined. Only one additional test set is allowed.

Ultimate load – The initial test consists of 20 specimens.

- If no more than two values are below the requirement, the sample passes.
- If three or four values are below the requirement, test an additional set.
- If five or more values are below the requirement, the sample fails.
- If 20 additional panels are tested, the combined passing rate shall be at least 90%.

6.2.3 Dimensional stability

One of the following linear expansion test methods and associated criteria shall be satisfied as noted for the grade in Section 5.3.2.1. Any special feature included by the manufacturer, such as coatings or moisture conditioning, shall be stated for Section 6.3.

- a. **Exposure to 50% ($\pm 5\%$) relative humidity; 21°C ± 6 °C (70°F ± 10 °F) and vacuum-pressure soak** – A minimum of 10 specimens (taken from at least 5 panels) both along and across the panel strength axis shall be conducted according to Section 7.8 for linear expansion measured from 50% relative humidity to vacuum-pressure soak.

The average linear expansion from each panel axis, as measured according to the test method from 50% relative humidity to vacuum-pressure soak, shall be no greater than specified.

Additional tests – If the average linear expansion exceeds 0.55%, the test fails. If the average linear expansion fails to meet the linear expansion requirement and is no greater than 0.55%, another lot of 10 specimens for a given panel axis shall be permitted. If the combined average of all the specimens meets the specified criteria, the requirement shall be considered satisfied.

- b. **Exposure to one-sided wetting and relative humidity** – Test a maximum of 20 specimens taken from at least 10 panels. Ten specimens (taken from at least 5 panels) for both along and across the panel strength axis shall be evaluated for linear and/or thickness expansion measured from as-received to wet-one-side exposure according to Section 7.9. Ten specimens (taken from at least 5 panels) for both along and across the panel strength axis shall be evaluated for linear and/or thickness expansion measured when exposed to relative humidity change according to Section 7.10.

Each panel axis is evaluated separately. The initial test consists of 10 specimens. If additional test sets are needed, they shall also consist of 10 specimens, and the results of the two 10-specimen sets shall be combined. Only one additional test set is allowed. If the combined results meet or exceed the minimum passing rate, the sample passes.

- If no more than three values are above the requirement, the sample passes.
- If four, five or six values are above the requirement, test an additional set.
- If seven or more samples are above the requirement, the sample fails.
- If ten additional specimens are tested, the minimum passing rate is 70%.

6.2.4 Bond performance

6.2.4.1 Bond classification

Bond classification performance tests shall be conducted as follows:

- a. **Exterior Plywood** – Plywood rated as Exterior shall satisfy PS 1 bond requirements for Exterior panels.
- b. **Exposure 1 Plywood** – Plywood rated as Exposure 1 shall satisfy PS 1 bond requirements for Exposure 1.
- c. **Exposure 1 Composite panels** – Composite panels rated as Exposure 1 shall have one sample (of at least five specimens) from each of at least 20 panels tested according to Section 7.17 and evaluated for delamination according to Section 7.13 following the fourth and sixth moisture cycles. At least 95% of the samples shall pass four moisture cycles, and 90% shall pass six moisture cycles. If more than 85% but fewer than 90% of the samples pass delamination requirements following the six-cycle test of Section 7.17 and evaluated according to Section 7.13, one additional test set of 20 samples shall be permitted. If the additional test results meet the requirements, bond performance requirements shall be considered satisfied.
- d. **Exposure 1 OSB** – OSB shall satisfy the requirements of this section or the requirements of Section 6.2.4.1.e. To satisfy the requirements of this section, OSB rated as Exposure 1 shall have one sample (of at least two specimens) from each of at least 20 panels tested for parallel strength according to Section 7.6 after cycling according to Section 7.16. If no more than one of the samples is below the minimum criterion in Table 7, the 20-panel test set shall be considered passing. If four or more samples fall below the minimum requirement, the test set shall be considered failing. If two or three of the samples are below the minimum criterion, an additional test set of 20 samples from the same lot shall be allowed. The combined passing rate of the 40-panel test set shall be 92.5% or greater.

- e. **Exposure 1 mat-formed panels** – Mat-formed panels rated as Exposure 1 shall have one sample (of at least five specimens) from each of at least 20 panels cycled according to Section 7.17 and tested for strength retention according to Section 7.7. Strength retention is calculated by the following method:

$$\%RS = \frac{P_t}{P_c} \times 100$$

where % RS = Percent retained strength of sample.
P_t = Average of five-specimen breaking load after cycling.
P_c* = Average unexposed sample (five-specimen) breaking load.

*Unexposed (control) specimens are broken in the as-received condition.

Samples tested shall exhibit the specified minimum strength retention following six moisture cycles.⁴

Additional tests - If the 20-sample average strength retention meets the requirements, but no more than one sample fails to meet the minimum individual strength retention specified, an additional test of 20 samples (one sample from each of 20 panels) shall be permitted. The combined passing rate of the 40-panel test set shall be 97.5% or greater.

6.2.4.2 **Bond performance of plywood with knots and knotholes**

Structural-use plywood rated as Exposure 1 shall be tested according to Sections 7.18 and 7.19. Knots and/or knotholes in the samples tested shall be greater than 51 mm (2 in.) but not exceeding 76 mm (3 in.) in width measured across the grain. Twenty samples with knots and/or knotholes shall be tested according to Section 7.18 and 20 according to Section 7.19.

Samples with knots and/or knotholes tested according to Section 7.18 shall meet dry concentrated static and impact requirements, conformance criteria and additional test set options of Table 2 and Sections 6.2.2.1.(a) and 6.2.2.1.(b). For each lot of 20, 95% of the samples with knots and/or knotholes tested according to Section 7.19 shall not exhibit delamination extending radially more than 19.1 mm (3/4 in.) beyond the boundary of the knot or knothole and across the width of a full sector or the continuous equivalent of the width of a full sector as measured by Section 7.19.4.

Additional tests – If no more than two samples with knots or knotholes in a lot of 20 fail to meet the test requirements, another lot of 20 tests for that requirement shall be permitted. If all specimens pass the additional tests, the requirements shall be considered satisfied.

6.2.5 **Adhesive performance**

6.2.5.1 **Adhesive mold resistance**

Four panels shall be tested according to the procedures of Section 7.14.

- a. Plywood shall be considered to have satisfactory adhesive mold resistance if each test group (see Section 7.14.2 for group definition) over the 20-week period shows an average glueline shear load of at least 90% of the control. In addition, no more than two groups shall rate less than 80%, and no single group shall rate less than 75%.
- b. Other panels shall be considered to have satisfactory mold resistance if no test group average is less than the control sample average minus 1.8 times the control sample standard deviation.

6.2.5.2 **Adhesive resistance to elevated temperature**

Adhesives satisfying the moisture-cycling requirements of Section 6.2.4.1 shall be considered to have satisfactory resistance to elevated temperature.

6.2.5.3 **Adhesive resistance to bacteria**

At least four panels shall be tested according to procedures of Section 7.15.

⁴ Because of the extreme severity of the six-cycle test, the strength retention requirement relates to bond performance and does not relate to structural design values.

- a. Plywood shall be considered to have adhesive bacteria resistance if each test group (see Section 7.15.2 for group definition) over the 12-week test shows an average load of at least 80% of the control. No single group shall rate below 70% of the control.
- b. Other panels shall be considered to have satisfactory bacteria resistance if no test group average is less than the control sample average minus 1.8 times the control sample standard deviation.

6.3 Mill specification

When a product passes the appropriate performance qualification tests of Section 6.2, a proprietary mill specification unique to the product and mill shall be written based on product evaluation under this section.

The product evaluation shall be based on values developed in this Standard and unique characteristics of the same materials supplied by the manufacturer for performance qualification testing. Reference values (see Section 2.10) shall be established during product evaluation or from applicable performance requirements in this Standard (Section 5) and shall be the basis for quality evaluation of future production. Reference values for mechanical properties may be based on Sections 6.3.2.1 or 6.3.2.2. Minimum industry reference values for small bending tests are found in Tables 7 and 8. Mill specific small bending values based on Section 7.6 or mill specific 1" x 5" bending reference values based on Section 7.7 may be determined based on certification agency approved methods. For plywood and composite panels, the grade and construction requirements are permitted for use in lieu of reference values for quality evaluation purposes. These values or characteristics will be used by both the individual mill quality procedures and by an inspection program of a qualified inspection and testing agency (see Section 8.2) in conjunction with its policies.

In addition to the panel characteristics specifically evaluated in this section, any unique manufacturing techniques which influence product qualification shall be included in the individual mill specification. This includes special coatings; heat, water or chemical treatments; overlays; additives; or other manufacturing-related activities. In addition, the maximum size knot or knothole tested according to Section 6.2.4.2 shall be included in the mill specification.

6.3.1 Panel construction

6.3.1.1 Plywood panels

Panels shall be defined as to species and veneer construction for the mill specification and evaluated under Sections 6.3.2 and 6.3.3, but excluding Section 6.3.3.2.

6.3.1.2 Composite panels

Wood-based material shall be evaluated as required in Sections 6.3.2, 6.3.3.1 and 6.3.4. In addition, the finished (veneered) panel shall be evaluated by the provisions of Sections 6.3.2, 6.3.3.1, 6.3.3.3 and 6.3.4.

6.3.1.3 Mat-formed panels

Mat-formed panels shall be evaluated under the provisions of Sections 6.3.2, 6.3.3 and 6.3.4.

6.3.2 Mechanical properties

6.3.2.1 Large-panel bending stiffness and strength

Twenty tests (specimens taken from at least 10 panels) shall be evaluated for bending stiffness both along and across the panel strength axis according to the procedures of Section 7.5.

Stiffness reference values for each panel direction shall be the lower value of a 90% confidence interval established on the average.

Strength reference values for each panel direction shall be the minimum observed value, or the sample average minus 1.8 times the sample standard deviation, whichever is the higher value.

6.3.2.2 Small specimen bending stiffness and strength

For OSB and other mat-formed panels, 20 samples (of at least 2 specimens) taken from at least 10 panels shall be evaluated for dry bending strength and stiffness both along and across the panel strength axis according to the procedures of Section 7.6.

Reference values for Quality Assurance for OSB are found in Table 8.

ADVISORY NOTE: Reference values in Table 8 are based on properties and statistical limits from representative industry samples that were tested for and met structural performance requirements in Section 6.2.2.1 and Table 2. Reference values for other mat-formed panels should be based on the statistical principles in Section 6.3.4.2.

End Use - Span Rating or Performance Category	BENDING STIFFNESS, EI x 10 ³				BENDING STRENGTH, MM			
	Stress Applied Parallel to Strength Axis ^(b)		Stress Applied Perpendicular to Strength Axis ^(b)		Stress Applied Parallel to Strength Axis ^(b)		Stress Applied Perpendicular to Strength Axis ^(b)	
	N- mm ² / mm	lbf- in. ² /ft width	N- mm ² /mm	lbf- in. ² /ft width	N- mm/mm	lbf-in./ft width	N- mm/mm	lbf- in./ft width
Sheathing								
Roof – 24	292	31	85	9	330	880	130	350
Roof - 24/Subfloor -16	395	42	94	10	390	1,040	140	370
Roof - 32/Subfloor - 16	490	52	113	12	460	1,250	190	520
Roof - 40/Subfloor - 20	1,240	132	358	38	810	2,170	360	970
Roof - 48/Subfloor - 24	1,790	190	763	81	920	2,480	510	1,380
Structural I								
3/8	292	31	85	9	330	880	130	350
7/16	395	42	141	15	390	1,040	220	580
15/32	490	52	245	26	460	1,250	320	860
½	490	52	273	29	460	1,250	330	900
19/32 & 5/8	1,240	132	471	50	810	2,170	500	1,360
23/32 & 3/4	1,790	190	716	76	920	2,480	650	1,760
Single Floor								
Single Floor - 16	876	93	198	21	650	1,740	230	630
Single Floor - 20	1,110	118	264	28	710	1,910	240	650
Single Floor - 24	1,600	170	546	58	910	2,450	320	850
Single Floor - 32	4,170	443	1,270	135	1,570	4,240	600	1,610
Single Floor - 48	8,660	920	2,110	224	2,080	5,600	820	2,200
^(a) Test criteria shall not be used for design properties.								
^(b) The strength axis is parallel to the face and back orientation of the flakes or strands unless otherwise indicated.								
^(c) Other reference values may be established through acceptable performance based on procedures in Section 6.2.2.1.								

6.3.3 Physical properties

6.3.3.1 Panel thickness

Finished panel thickness shall be evaluated on each of 20 panels by the procedures of Section 7.12. The reference value shall be the average less 1.932 standard deviations for 20 panels (the 95% lower tolerance limit at 75% confidence based on ASTM D-2915).

6.3.3.2 Moisture content

Panel moisture content shall be measured on one specimen from each of 20 panels according to Section 7.11. The reference value shall be the maximum panel moisture content. A reference value shall be established only if necessary under dimensional stability performance testing per Section 6.2.3.

6.3.3.3 Linear expansion

Reference values for linear expansion are to be based on specimens taken from at least 20 panels per the instructions in either Procedure A or Procedure B of Section 7.8. If the average linear expansion based on Procedure A exceeds 0.5%, reference values shall be based on specimens taken from 20 panels evaluated using Section 7.8.2.1. The reference value shall be the highest observed value, or the sample average plus 1.8 times the sample standard deviation, whichever is the lower value. If Procedure B is used, the reference value shall be 0.5%.

For composite panels and for mat-formed panels containing non-oriented furnish, one specimen 75 x 300 mm (3 x 12 in.) shall be prepared perpendicular to the machine direction only from each panel to be tested.

For OSB and other mat-formed panels containing oriented furnish, one 75 x 300 mm (3 x 12 in.) specimen parallel and one perpendicular to the panel strength axis shall be prepared from each panel to be tested. Separate parallel and perpendicular reference values shall be determined when using Section 7.8.2.1 Procedure A.

6.3.4 Adhesive bond properties

6.3.4.1 Exposure 1 bond performance for OSB

The reference values for an OSB mill specification shall be established based on 20 samples evaluated parallel to the strength axis according to Section 7.6 after cycling according to Section 7.16, or based on procedures as described in Section 6.3.4.2 or based on the tabulated values in Table 7.

6.3.4.2 Exposure 1 bond performance for composites and mat-formed panels.

For composite and mat-formed panels classified Exposure 1, a minimum of 20 samples, one taken from each of 20 panels, shall be moisture cycled according to the procedures of Section 7.16 (single cycle soak-dry test) using specimens described in Section 7.7. For composite and mat-formed panels classified Exposure 1, a minimum of 20 samples, one taken from each of 20 panels, shall be moisture cycled according to the procedures of Section 7.17 (6-cycle test) using specimens described in Section 7.7. Immediately after cycling, composite samples will be evaluated for delamination based on procedures described in Section 7.13. Moisture-cycled samples shall then be tested according to the procedures of Section 7.13. The individual panel reference value for each qualification shall be the lowest observed breaking load (5-specimen average) or the sample average minus 1.8 times the sample standard deviation, whichever is the higher value. In addition, for Exposure 1 panels tested according to Sections 7.16 and 7.7, the lower 90% confidence interval shall be established on the qualification average.

6.3.4.3 Exposure 1 bond performance of plywood panels

Reference values for bond performance of Exposure 1 plywood panels shall be as specified in Section 6.2.4.1.(b).

6.3.4.4 Bond performance associated with knots and knotholes

Reference values for bond performance associated with knots and knotholes shall be as specified in Section 6.2.4.2 for knots and knotholes tested according to Section 7.19.

ADVISORY NOTE: Assessment of bond performance associated with knots and knotholes on a quality auditing basis should be conducted when a maximum-sized knot or knothole appears in the routine bond performance samples. When available, they should be tested according to Section 7.19 and meet the criteria of Section 6.2.4.2.

7 TEST METHODS

7.1 Concentrated static and impact load test

ASTM E-661 shall be followed except as modified in these sections.

The test span shall be 19.2 inch for the span rating of 20.

The dry test condition shall be within +/- 3% of the as-shipped moisture content. The wet test condition shall be exposure to three days of continuous one-sided wetting, then tested wet. The wet/redry condition shall be exposure to three days of continuous one-sided wetting, followed by drying. The panel moisture content at the time of testing for the wet/redry condition shall be within +/- 3% of the as-shipped moisture content.

7.1.1 Specimen preparation

ASTM E-661 shall be followed with regard to specimen preparation, and Section 6.2.2.1 of PS 2 shall be followed with regard to the number of specimens required. Specimens shall also be moisture cycled as required.

7.1.2 Test procedure

Concentrated static – Procedures of ASTM E-661 shall be followed, except that a test frame of steel rather than lumber, using fasteners that simulate nails, shall be permitted. During measurement of deflection, the loading rate shall be 445 N (100 lbf) per 30 seconds. Following measurement of deflection, the rate of loading shall yield failure within 5 minutes if a hand-pumped hydraulic loading system is used.

Concentrated impact – Procedures of ASTM E-661 Method A shall be followed, except:

1. A test frame of steel rather than lumber, using fasteners that simulate nails, shall be permitted.
2. For span ratings greater than 24, the shot bag shall weigh 27 kg (60 lbs).

The width of individual test pieces shall be at least 610 mm (24 in.) for span ratings up to 24, and 1,220 mm (48 in.) for greater span ratings.

7.2 Uniform load test

7.2.1 General

This method covers a procedure for determining the performance of structural-use panels under uniform loads such as snow, wind and occupancy loads. The uniform load shall be applied by drawing a vacuum under the test specimen. This causes atmospheric pressure to apply a uniform load to the test specimen. The specimen shall be mounted on fully supported framing members in a vacuum chamber.

7.2.2 Equipment

Vacuum chamber – The vacuum chamber (Figures 1 and 2) shall consist of a sealed box with the panel to be tested forming the top. A 0.15-mm (6-mil) polyethylene sheet or equivalent, the perimeter of which shall be attached securely with tape, shall seal the top surface of the vacuum chamber. The chamber shall be strong and rigid to resist the applied load without failure or excessive deformation. A vacuum pump shall be used to reduce the air pressure under the specimen. The load shall be measured with absolute pressure gages for electronic data readout, but manometers or vacuum gages shall also be permitted.

Joist supports – The framing members shall be supported so as to resist deflection or rotation under applied load.

Deflection gages – The deflection gages shall be mounted to rigid tripods whose legs shall rest above the joists. Deflection shall be measured to the nearest 0.025 mm (0.001 in.).

7.2.3 Specimen preparation

Samples selected shall be representative of the product being tested.

Length – The specimen length perpendicular to the framing members shall be equal to twice the center-to-center spacing.

Width – The specimen width shall be at least 595 mm (23.5 in.).

Thickness – The specimen thickness shall be measured and recorded after conditioning.

Conditioning – Prior to testing, specimens shall be conditioned as specified in Table 3.

7.2.4 Test procedure

Following preparation of specimens in Section 7.2.3, the specimen to be tested shall be mounted on framing members in the vacuum chamber at the spacing for which the panel is being rated, following the specified nail size and spacing. The top of the vacuum chamber shall then be sealed with the polyethylene sheet, and the tripod holding the deflection gages shall be set in its proper position with the gages positioned to read deflection at the point of maximum deflection⁵ within the two outer spans (Figures 3 and 4).

⁵ The point of maximum deflection for a uniformly loaded two-span system occurs at 0.4215 times (S) measured from the centerline of the outer joist, where S equals the center-to-center joist spacing.

Figure 1. Vacuum Test Chamber Equipment
Diagram shows strength axis across supports.

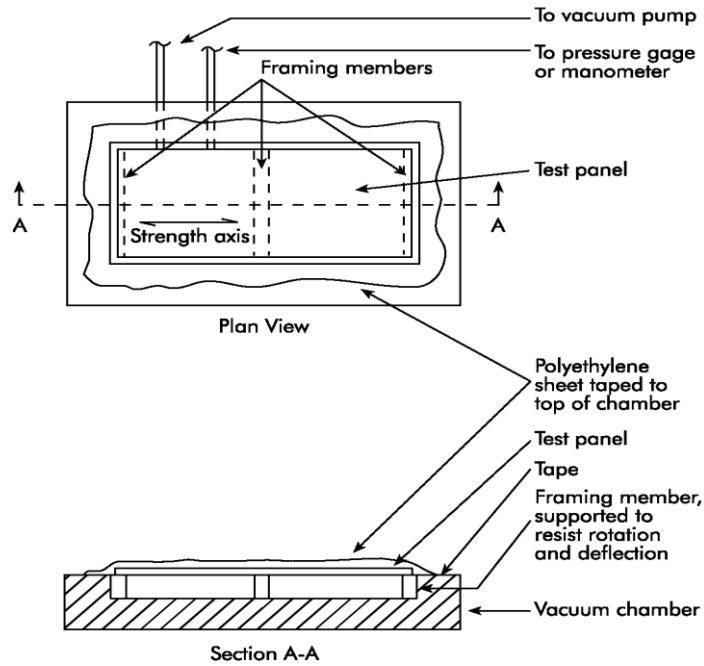

Figure 2. Vacuum Test Chamber Equipment
Diagram shows strength axis parallel to supports.

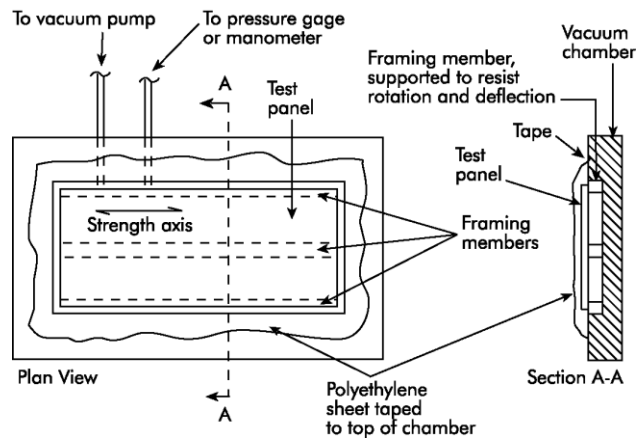
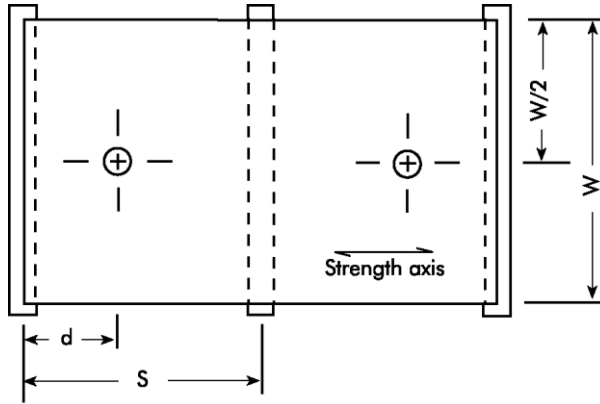
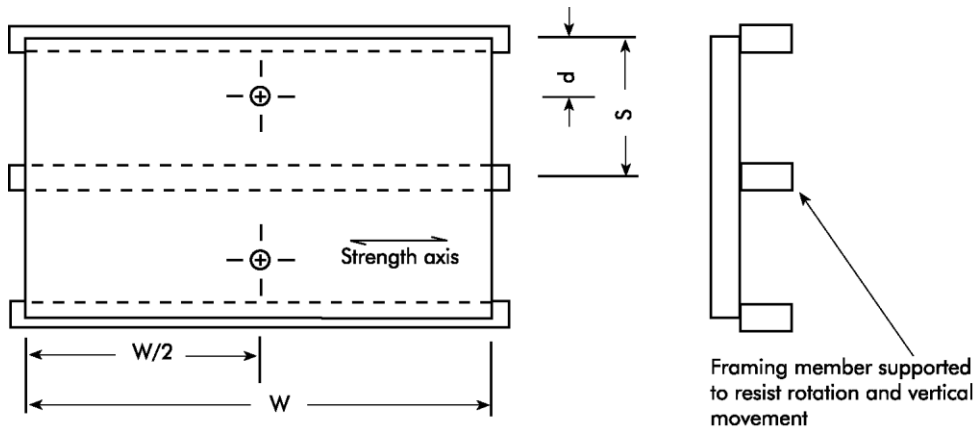

Figure 3. Uniform Load Test Specimen
Diagram shows Strength axis across supports.



S = Center-to-center support spacing.
 $d = 0.4215(S)$ for two span.
 W = Panel width, minimum = 595 mm (23.5 in.).
 \oplus = Location of deflection measurement

Figure 4. Uniform Load Test Specimen
Diagram shows strength axis parallel to supports.



S = Center-to-center support spacing.
 $d = 0.4215(S)$ for two span.
 W = Panel width, minimum = 595 mm (23.5 in.).
 \oplus = Location of deflection measurement

The panel shall be loaded at a uniform rate of 2.4 kPa (50 lbf/ft²) per minute, recording deflections at 1.2 kPa (25 lbf/ft²) increments until maximum load is achieved or until the desired proof load is achieved as required. Deflection data shall be required only in sufficient numbers to develop the straight-line portion of the load-deflection curve. In no case shall the number of data points be less than six. Deflection at a given load shall be determined by translating the slope to pass through the origin, thereby correcting for any settling of the system.

7.3 Wall racking load test

7.3.1 General

The principles of Section 14 of ASTM E-72 for wall racking shall be followed.

7.3.2 Specimen preparation

Test specimens 2.4 x 2.4 m (8 x 8 ft) shall be prepared as in ASTM E-72, except that the 89 x 89 mm (nominal 4 x 4 in.) timber attached to the upper plate shall be reinforced with a 100 x 150 mm (4 x 6 in.) steel tube to prevent excessive deformation. An additional vertical deflection gage shall be positioned in the lower right corner of the wall (Figure 7 of ASTM E-72) to record crushing of the lower plate.

Stud framing shall be Douglas-fir or southern pine stud grade, with a moisture content of 15% or less. Nail size and spacing shall be as specified in Table 5. When 3.8 x 76 mm (0.148 x 3.0 in.) nails are used, 64 mm (nominal 3 in.) wide framing shall be used for the center stud (at panel joint) to prevent splitting of framing member.

Specimens shall be tested in the dry condition (see Table 5, footnote b).

7.3.3 Test procedure

Load shall be applied continuously at a uniform rate of load. The rate of loading shall be chosen such that the 1-times test load shall be reached in not less than 2 minutes. The loading rate for the subsequent loading cycles shall be the same as the 1-times test load cycle.

Deflection measurements shall be recorded as the wall is being loaded. At least 10 sets of uniformly-spaced deflection readings shall be taken prior to failure to establish the load-deflection curve. At 1-times and 2-times the test load specified in Table 5, the load shall be removed and the wall shall be allowed to recover for 5 minutes. At 2.5 times the test load, the deflection gages may be removed and the wall shall be loaded to failure.

Deflection shall be reported after removing panel uplift, base slip and crushing components from the total deflection measurement. Ultimate load shall be recorded.

7.4 Fastener-holding resistance test

7.4.1 General

Tests shall measure the single-shear resistance of a nail to lateral movement of the panel. The procedure shall generate data which are to be compared to data from other panel products, but the procedure shall not be used to produce joint design information.

Direct withdrawal loads shall also be measured.

Conditioning – Prior to testing, specimens shall be conditioned as specified in Table 6.

7.4.2 Specimen preparation

Lateral loads – Each specimen shall measure 150 x 150 mm (6 x 6 in.). To serve as test points, four points shall be marked on the centerline of each specimen axis, 25 mm (1 in.) in from each edge. Nail size shall be as required in Table 6.

Nails shall be driven perpendicular to the face of the panel following conditioning. Nail penetration shall be such that the nail head lies flush with the panel face. A backing shall be used to prevent the nail from tearing away the back during driving. All nails shall be driven immediately prior to testing.

Direct withdrawal loads – Test specimens shall be of convenient size (at least 75 x 150 mm [3 x 6 in.]) trimmed from the lateral resistance specimens. Nail size shall be as required. Following conditioning, nails shall be driven through the panel perpendicular to the face and at least 12 mm (1/2 in.) of the shank portion shall project above the surface of the material.

Figure 5. Exploded View of Test Apparatus for Measuring the Lateral Nail-Holding Capacity of Structural Panel Products

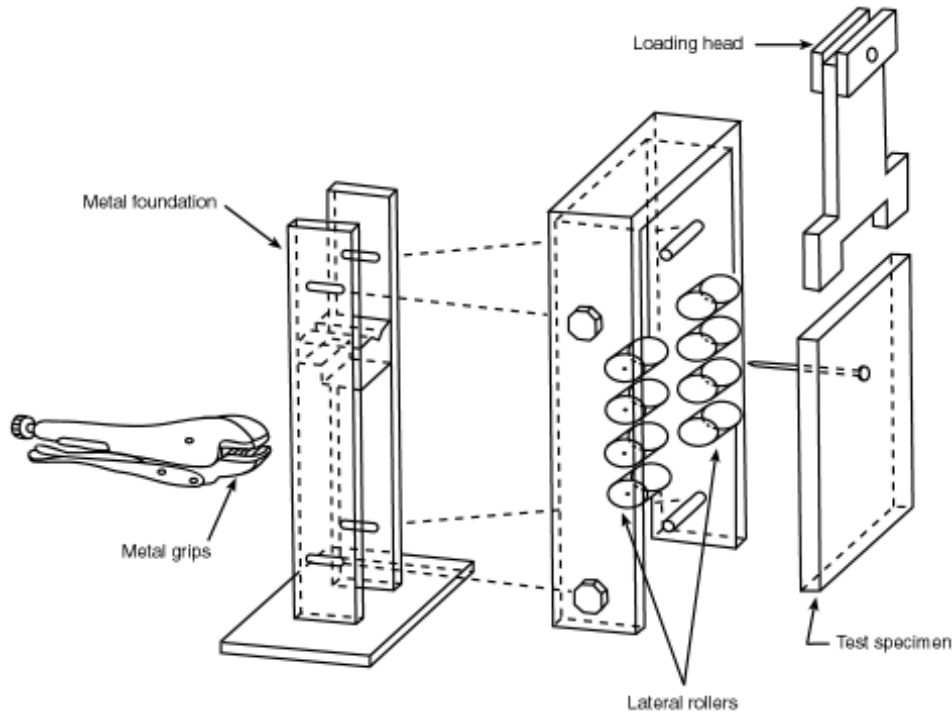

7.4.3 Test procedure

Lateral loads – The fastener shall be loaded in single shear. Apparatus similar to that shown in Figure 5 shall be employed. The nail shank shall be rigidly clamped. Rollers shall be present to insure vertical movement by providing lateral restraint to the panel. Load shall be applied through a yoke-type loading head. One such loading head is illustrated in Figure 5.

The test specimen shall be loaded continuously throughout the test by uniform motion of the movable crosshead of the test machine at a rate of 5 mm (0.2 in.) per minute.

Direct withdrawal loads – Nail holding tests shall be made on nails driven through the thickness of the panel to measure the resistance to withdrawal in a plane perpendicular to the face.

Method of loading shall be in accordance with ASTM D-1761, Section 10.2.

The specimen shall be loaded continuously throughout the test by uniform motion of the movable head of the testing machine at a rate of 5 mm (0.2 in.) per minute.

7.5 Large panel bending test

7.5.1 General

This test procedure determines large panel bending strength and stiffness. The general provisions of ASTM D-3043 Method C shall be followed.

7.5.2 Specimen preparation

Specimens shall be prepared according to ASTM D-3043 Method C, except specimen sizes not less than 310 x 1,220 mm (12 x 48 in.) shall be permitted.

7.5.3 Test procedure

The procedures of ASTM D-3043 Method C shall be followed except specimens shall be tested for stiffness both along and across the panel strength axis, and maximum bending moment shall be determined as required.

7.6 Small static bending test for OSB

7.6.1 General

This test is intended to develop bending strength and stiffness information to be used for quality assurance purposes. The test method follows the principles of ASTM D-3043, Method D. The information developed shall not be considered as appropriate for the purposes of developing design data.

7.6.2 Specimen preparation

Specimens are cut from each sample according to ASTM D-3043 Section 8.2, except that specimen width shall be 115 mm (4.5 in.).

7.6.3 Test procedure

The principles of ASTM D-3043 Sections 8.1 – 8.6 are followed, except that specimens shall be cut to the following length:

355 mm (14 in.) for panels with Performance Category of 1/2 and less,

510 mm (20 in.) for panels with Performance Category greater than 1/2 up to 3/4,

610 mm (24 in.) times Performance Category plus 50 mm (2 in.) for panels with Performance Category greater than 3/4.

7.7 Small static (25 mm x 125 mm [1 in. x 5 in.]) bending test for composites and mat-formed panels

7.7.1 General

This test is intended to develop strength information which acts as a measure of bond integrity. The test shall be run on control and moisture-cycled specimens.

7.7.2 Specimen preparation

Fifteen 25 x 125 mm (1 in. x 5 in.) test specimens shall be cut from each sample to be tested (15 from each direction in the case of panels which exhibit directional properties). Side-by-side matching shall be observed for comparison of control, single cycle and six-cycle exposures. Specimens prepared from panels containing veneer shall be cut with the grain of the veneer parallel to the 125 mm (5 in.) dimension. Specimens prepared from mat-formed panels shall be cut so that the 125 mm (5 in.) dimension of the specimens shall be parallel to the panel strength axis except for panels exhibiting directional properties, in which case five specimens shall be cut along both axes. Specimens shall then be tested following appropriate conditioning.

7.7.3 Test procedure

Each specimen shall be tested as a beam across a 100 mm (4 in.) clear span with the loading head and supports measuring 19.1 mm (3/4 in.) in diameter. The load shall be applied at mid-span at a rate not to exceed 25 mm (1 in.) per minute until failure occurs. Specimens from veneered composite panels shall be oriented so that the thickness of the specimen acts as the depth of the beam. Specimens from mat-formed panels shall be oriented so that the 25 mm (1 in.) cut dimension acts as the depth of the beam and the panel thickness acts as the beam width. The breaking load for each specimen shall be measured to ± 4.4 N (± 1 lbf). The average breaking load for each panel shall be calculated. In the case of panels that exhibit directional properties, separate averages shall be determined for each specimen direction. Average values shall be reported.

7.8 Linear expansion test measured from oven-dry or 50% relative humidity to vacuum-pressure soak

7.8.1 General

This test method provides evaluation of a panel's dimensional stability.

7.8.2 Specimen preparation

Test specimens shall be cut at least 75 mm (3 in.) wide by at least 300 mm (12 in.) long and prepared for both panel directions.

Specimens shall be selected to avoid large characteristics such as knotholes, knots, or splits in the outer veneers (when veneers are present), especially near the eyelet locations. Otherwise, normal grade features shall be included as they occur.

Fixed reference points which serve as measuring points on the centerline of each specimen shall be located 25 mm (1 in.) in from each end. Brass eyelets placed in pre-bored holes have been found to be suitable reference points. Use of the reference measuring points shall permit determination of linear expansion independent of any additional swelling that might take place at the exposed panel edge.

7.8.2.1 Test procedure

Specimen pre-conditioning:

Procedure A

Specimens shall be oven-dried at $103\pm 2^{\circ}\text{C}$ ($217\pm 4^{\circ}\text{F}$) for 24 hours or until constant weight is attained. Constant weight shall be assumed when consecutive readings taken at least 2 hours apart agree within 0.2%.

Procedure B

Specimens shall be conditioned at 50% $\pm 5\%$ relative humidity and $21^{\circ}\pm 6^{\circ}\text{C}$ ($70^{\circ}\pm 10^{\circ}\text{F}$) until constant weight is attained. Constant weight shall be assumed when consecutive readings taken at least 24 hours apart agree within 0.2%.

Measurement and vacuum-pressure soak cycle:

After pre-conditioning using either Procedure A or B, the specimen shall then be placed in a flattening jig to remove any out-of-plane distortions, and the distance between gage points shall be measured to the nearest 0.025 mm (0.001 in.) with a bar-type trammel equipped with a dial gage.

Following the pre-conditioned measurements, specimens shall be placed in a pressure cylinder, flooded with $18\pm 6^{\circ}\text{C}$ ($65\pm 10^{\circ}\text{F}$) tap water and subjected to a vacuum of 91 ± 7 kPa (27 ± 2 in. of mercury) for 1 hour (time shall not begin until full vacuum is achieved). Specimens shall then be subjected to 2 hours of pressure not to exceed 690 kPa (100 psi). After wet exposure, specimens shall be removed from the cylinder and remeasured for length.

Expansion values shall be calculated as a percentage of the pre-conditioned (oven-dry or relative humidity) dimension, as given in the following equations:

Calculation:

Procedure A (oven-dry)

$$\text{Percent Change} = \frac{L_w - L_d}{L_d} \times 100$$

where: L_w = dimension saturated
 L_d = dimension oven-dry

Procedure B (relative humidity)

$$\text{Percent Change} = \frac{L_w - L_{50\%}}{L_{50\%}} \times 100$$

where: L_w = dimension saturated
 $L_{50\%}$ = dimension equilibrated at 50% RH

7.9 Linear expansion and thickness swell test measured after wetting one side

7.9.1 General

This performance test is designed to measure linear expansion and edge thickness swell.

7.9.2 Specimen preparation

Each 1,220 x 1,220 mm (48x 48 in.) specimen shall have only one cut edge; the remaining three being as prepared by the manufacturer. To serve as measuring points for linear expansion, brass eyelets shall be placed in four pre-bored holes on the centerline of each specimen axis, 25 mm (1 in.) in from each edge. This shall result in a nominal 1,170 mm (46 in.) gage distance both along and across the panel strength axis.

Additionally, points shall be marked on each uncut side of the specimen for thickness swell evaluation. Thickness shall be measured according to Section 7.12.

Moisture content (oven-dry basis) shall be measured according to Section 7.11 prior to testing in a panel from the same lot. When the moisture content of the specimens exceeds 12%, the specimens shall be conditioned to constant weight at 20±3°C (68±6°F) and 65±5% relative humidity to achieve equilibrium moisture content. Constant weight shall be assumed when consecutive readings taken at least 24 hours apart agree within 0.2%.

7.9.3 Test procedure

Linear expansion specimens shall be placed in a flattening jig to remove any out-of-plane distortions, and the distance between gage points shall be measured to the nearest 0.025 mm (0.001 in.) with a bar-type trammel equipped with a dial gage. Thickness shall be measured along the edge to the nearest 0.025 mm (0.001 in.) with a micrometer, applying ratchet pressure during measuring.

Following these as-received measurements, unrestrained specimens shall be mounted within 30 degrees of vertical and shall be wetted on one side with water at 18±6°C (65±10°F). The period of continuous wetting shall be 14 days. No liquid water shall impinge on the back. The back shall be exposed to any water vapor present. All factory edges shall be exposed to water except the freshly-cut edge. The cut edge shall be the top edge, and protection with an edge sealer shall be permitted. After wet exposure, the specimens shall be remeasured.

Expansion values shall be calculated to express results as a percentage of the original dimension, as given in the equation:

$$\text{Percent Change} = \frac{L_w - L_{ar}}{L_{ar}} \times 100$$

where: L_w = dimension saturated
 L_{ar} = dimension as received (less than 12% MC)

7.10 Linear and thickness expansion test measured by exposure to relative humidity

7.10.1 General

This method measures linear expansion in accordance with ASTM D-1037, Sections 108 to 111, *Linear Variation with Change in Moisture Content*.

Thickness expansion, where applicable, shall be measured as described in Sections 7.10.2 and 7.10.3.

7.10.2 Specimen preparation

From each sample, two specimens shall be cut according to the procedures of ASTM D-1037, Sections 108 to 111. Test specimens shall be cut 75 mm wide by 1,040 mm long (3 x 41 in.). Shorter lengths shall be permitted, but specimens shall not be less than 300 mm (12 in.) long. To serve as measuring points for linear expansion, brass eyelets shall be placed in pre-bored holes on the centerline of each specimen, 25 mm (1 in.) in from each end. This shall result in a nominal 990 mm (39 in.) gage distance.

Additionally, points shall be selected and marked on the centerline of the specimen 75 mm (3 in.) in from each end to serve as measuring points for thickness expansion.

7.10.3 Test procedure

The procedures of ASTM D-1037, Sections 108 to 111, shall be followed for linear expansion testing, except that specimens shall be placed in a flattening jig to remove any out-of-plane distortions, and the distance between gage points shall be measured to the nearest 0.025 mm (0.001 in.) with a bar-type trammel equipped with a dial gage. Thickness shall be measured to the nearest 0.025 mm (0.001 in.) with a micrometer, applying ratchet pressure during measuring.

Expansion values shall be calculated to express results as a percentage of the 50% conditioned dimension, as given in the equation:

$$\text{Percent Change} = \frac{L_{90} - L_{50}}{L_{50}} \times 100$$

where: L_{90} = dimension equilibrated at 90% RH
 L_{50} = dimension equilibrated at 50% RH

7.11 Panel moisture content determination

7.11.1 General

This procedure defines the method of determining panel moisture content by the oven-dry method according to the principles of ASTM D-4442, method B.

7.11.2 Specimen preparation

From each panel, a specimen shall be cut at least 50 mm (2 in.) from any edge. If the specimen size is less than 150 x 150 mm (6 x 6 in.), the entire specimen shall be used.

7.11.3 Test procedure

The specimen weight shall be obtained ($\pm 0.2\%$) and the specimen placed in a drying oven at $103 \pm 2^\circ\text{C}$ ($217 \pm 4^\circ\text{F}$) until constant weight is achieved. Constant weight shall be assumed when consecutive readings taken at least two hours apart agree within 0.2%.

The moisture content shall be calculated as:

$$M = \left[\frac{W_w - W_d}{W_d} \right] 100$$

where:

M = Moisture content (percent)
 W_w = Initial weight (grams or similar units)
 W_d = Oven-dry weight (grams or similar units)

7.12 Panel thickness determination

7.12.1 General

This method defines the procedure for determining panel thickness.

7.12.2 Specimen preparation

Panel condition at the time of measurement shall be noted.

7.12.3 Measurement method

Panel thickness shall be measured with a micrometer having 19.1 mm (3/4 in.) (minus 0, plus 1.3 mm [0.050 in.] diameter anvils. Measurements shall be taken at an applied anvil pressure of not less than 34 kPa (5 psi) or more than 69 kPa (10 psi). The location of the measurements shall be representative of general panel thickness at approximate mid-length along each edge of the panel and the average of the four measurements shall be taken as the thickness of that panel. If a measurement point contains a permissible grade characteristic that affects panel thickness, then the measurement point shall be shifted from that point.

7.13 Probe test for delamination

7.13.1 General

This test procedure defines a method for the determination of delamination in composite panels.

7.13.2 Equipment

The probe used shall measure 6.4 mm (1/4 in.) wide at the tip by 0.3 mm (0.012 in.) thick and shall increase in thickness to about 0.64 mm (0.025 in.), 12 mm (1/2 in.) from the tip. The 6.4 mm (1/4 in.) width shall increase to a width of 16 mm (5/8 in.) at 25 mm (1 in.) from the end. The probe shall be of any convenient length. The tip of the probe shall be squared off and not sharp so that when probing delaminations, fibers across the delaminated area will not be cut.

7.13.3 Specimen preparation

Five specimens shall be cut from each sample to 25 x 125 mm (1 x 5 in.) dimensions, avoiding knots, knotholes and other voids permitted in the grade, with grain of the outer plies in the long direction. Measurement of delamination shall take place prior to any mechanical test.

7.13.4 Test procedure

Delamination shall be evaluated according to the following procedure. The specimen shall be examined visually for delamination. Any separations in the specimen periphery in veneer-to-veneer or veneer-to-wood-based material glueline shall be probed to determine depth of delamination. A separation that is 6.4 mm (1/4 in.) deep for a continuous length of 25 mm (1 in.) shall be considered as having failed the test for delamination. Use of slight pressure is necessary when inserting the probe into the delaminated areas. The pressure shall be limited to that which is applied by gripping the probe between the thumb and first finger. In no case shall any prying action be used.

The number of specimens failing this test shall be reported.

7.14 Adhesive mold test

7.14.1 Equipment

Cabinets shall be used to house test specimens under mold-producing conditions. Each cabinet shall be divided into three interconnecting compartments with adjustable specimen trays, each with a sealed door in the front. On each side of the trays, toweling shall be suspended vertically with the lower ends in a water pan acting as wicking in order to provide maximum wet surface area. These pans shall rest on the floor of the mold cabinet under each compartment. The water level in these pans shall be kept 65 to 75 mm (2-1/2 to 3 in.) in depth.

In order to maintain a uniform temperature within the mold cabinets, a walk-in housing shall surround the cabinets. The temperature within this housing shall be maintained at 27°C (80°F) with a 500-watt heater controlled by a thermostat. Fan-forced air circulation sufficient to avoid stratification shall be used to ensure even temperature in all areas of the housing. No air circulation shall occur within the mold cabinets, since mold growth is dependent upon still air.

A uniform temperature shall be maintained in the housing around the cabinets.

7.14.2 Specimen preparation

Test specimens to be used for determination of mold resistance of the adhesive agent in the panel shall depend on the construction of the panels being tested. Plywood shall be tested by preparing plywood shear specimens as described in PS 1, kerfed to pull lathe checks closed for maximum breaking load.

Test specimens for testing composite panels and mat-formed panels shall be 25 x 125 mm (1 x 5 in.) in dimension. Composite panel specimens shall be cut with the veneer grain in the 125 mm (5 in.) dimension. Mat-formed panels shall be cut with the 125 mm (5 in.) dimension parallel to the panel strength axis, except in the case of panels containing oriented furnish, in which case two complete sets of specimens as described below shall be prepared, one set parallel and one set perpendicular to the panel strength axis.

The four panels to be mold tested shall be cut into 100 pairs of specimens (two sets of 100 pairs each in the case of oriented furnish). These paired specimens (mold test specimen and adjacent control specimen) shall be completely randomized and assembled into 10 groups of 20 specimens each for each direction tested (10 test specimens and 10 controls). The controls and test specimens for each group shall then be separated.

7.14.3 Test procedure

Prior to placing plywood specimens in the mold cabinet, they and their controls shall be stickered, given a five-second dip in tap water at room temperature, and then conditioned for one week at 95% ($\pm 2\%$) relative humidity and a temperature of 27°C (80°F) in a separate conditioning chamber. After one week, test and control specimens shall be removed. Test specimens shall be dusted with soybean flour and placed flat on green pine sapwood veneer strips that have been stored in the mold cabinet. A stack of these veneer strips and test specimens shall then be placed in the mold cabinet. The control specimens shall be allowed to dry at room conditions.

At two-week intervals, the designated mold groupings shall be removed from the cabinet and allowed to dry at room conditions for one week. Test specimens and corresponding control specimens shall then be tested as required. Ten of these groups shall be sufficient to test mold-resistant properties of plywood products.

Mold test specimens for composites and mat-formed products shall be subjected to the five-second dip in tap water and the one-week exposure at 95% ($\pm 2\%$) relative humidity and a temperature of 27°C (80°F) in a separate humidity chamber.

Control test specimens from composites and mat-formed products shall be subjected to testing according to Section 7.16. At two-week intervals, composites and mat-formed products from the mold test and moisture-cycled control specimens shall be dried at room conditions for one week and then tested according to Section 7.7.

7.15 Adhesive bacteria test

7.15.1 General

This method determines if an adhesive system possesses sufficient resistance to bacterial attack to retain bond integrity under conditions which promote bacterial growth.

7.15.2 Specimen preparation

Test specimen size shall depend on panel construction. Plywood panels shall use shear specimens described in PS 1, kerfed to pull lathe checks closed for maximum breaking load. Other panels shall use a specimen 25 x 125 mm (1 x 5 in.). Panels containing veneer shall be cut with the 125 mm (5 in.) dimension parallel to the grain. The veneer shall be completely free of knots, knotholes and other voids permitted in the grade.

Specimens from mat-formed panels shall be cut parallel to the panel strength axis, except for panels containing oriented furnish, in which case two complete sets of specimens shall be cut, one parallel and one perpendicular to the panel strength axis.

Sufficient material is needed to provide 80 specimens per set as required. Specimens within each set shall be numbered consecutively 1 through 80 as cut, with odd-numbered specimens destined for bacteria exposure and the adjacent even-numbered specimens destined for control. Ten odd-numbered specimens and their matching 10 even-numbered specimens shall then comprise an exposure group and control for that group. Four such groups shall be made up from the 80 specimens for each direction tested.

7.15.3 Test procedure

Plywood specimens, including the controls, shall be subjected to one-half hour vacuum and one-half hour pressure under tap water following the cycle used in the PS 1 vacuum-pressure test for Exterior plywood. Control specimens shall then be tested as required in the wet condition. The breaking load shall be recorded and control averages shall be determined for each of the exposure groups.

For composites and mat-formed products, all specimens shall be subjected to the vacuum-soak portion of the moisture cycle test of Section 7.16. Control specimens shall be dried according to the drying provisions of Section 7.16 and broken dry according to the procedures of Section 7.7, with the breaking load recorded and control averages determined for each of the exposure groups.

All specimens designated for the bacteria exposure shall be floated flat in a slurry of soybean flour, water and alder sawdust consisting of 7% soybean flour, 83% water and 10% alder sawdust (sawdust at 18% moisture content). To this slurry shall be added 0.3% by weight of a 50% solution of sodium hydroxide. The slurry shall be poured into trays, filling them to a depth of 25 mm (1 in.). (Note: Do not use copper trays.) These trays containing slurry and specimens shall then be placed into a cabinet described and maintained according to Section 7.14.

One exposure group shall be removed from the cabinet every three weeks over the twelve-week period of the test. Plywood specimens shall be tested wet according to the standard plywood shear test method. Specimens of composite and mat-formed products shall be dried according to the drying cycle of Section 7.16 and broken according to Section 7.7.

7.16 Moisture cycle test for bond performance (single cycle test)

7.16.1 General

This moisture cycle test is a quality control method to accelerate bond degradation. Following moisture cycling, a mechanical test is generally performed.

7.16.2 Specimen preparation

Specimen size and configuration shall depend upon the test to follow moisture cycling.

7.16.3 Test procedure

The specimens shall be placed in racks to ensure free movement of water and air around the specimens. The specimens shall then be placed in a vacuum-pressure vessel which is then filled with 66°C (150°F) water. A vacuum of 50.6 kPa (15 in. of mercury) shall be drawn on the vessel for 30 minutes. The vacuum shall then be released and the specimens shall be allowed to soak in the water at atmospheric pressure for 30 minutes. The vessel shall then be drained and the specimens dried for at least 15 hours at 82°C (180°F) in an oven with fan-forced air circulation of 45 to 50 air changes per minute. The specimens shall then be tested dry according to the appropriate test method.

7.17 Moisture cycle test for delamination and strength retention (six-cycle test)

7.17.1 General

This moisture cycle is used in evaluation of delamination and strength retention of products rated as Exposure 1.

7.17.2 Specimen preparation

Specimen size and configuration shall depend on the test to follow moisture cycling.

7.17.3 Test procedure

Specimens shall be placed in racks to ensure free movement of water and air around the specimens. The specimens shall then be placed in a vacuum-pressure vessel which is then filled with 66°C (150°F) water. A vacuum of 50.6 kPa (15 in.) of mercury shall be drawn on the vessel for 30 minutes. The vacuum shall then be released, and the specimens shall be allowed to soak in the water at atmospheric pressure for 30 minutes. They shall afterwards be removed and dried for 6 hours at 82°C (180°F) in an oven with fan-forced air circulation of 45 to 50 air changes per minute. Specimens shall then be returned to the pressure vessel and the vacuum-soak cycle repeated. Following the second vacuum-soak cycle, specimens shall again be placed in the oven and dried for 15 hours. This shall complete two cycles. Testing shall be continued for two additional days until 6 cycles have been completed. The specimens are then tested dry according to the appropriate test method.

7.18 Bond performance test for plywood with knots and knotholes

7.18.1 General

This is a moisture cycle and loading procedure for verifying resistance to deflection and damage under concentrated static and impact loads applied at the location of the maximum knot or knothole. The method is used to evaluate knots and knotholes greater than 51 mm (2 in.) but not exceeding 76 mm (3 in.) in width measured across the grain of Exposure 1 plywood panels.

7.18.2 Specimen preparation

From ten 1,220 x 2,440 mm (48 x 96 in.) panels, a specimen at least 595 mm (23.5 in.) wide by twice the span in length shall be cut. The test specimen shall be configured such that the subject knot or knothole is along a mid-test-span line and at least 295 mm (11-5/8 in.) from either edge. The subject knot shall be the maximum size (+0, -12 mm [+0, -1/2 in.]) permitted within the grade.

Each specimen shall be placed vertically in a tank and sprayed with water on both faces continuously for 72 hours. As an alternative to spraying, soaking panels continuously for 72 hours shall be permitted provided the height of the water level above the panels does not exceed 600 mm (24 in.). Panels shall then be redried until constant weight is reached at $20\pm 3^{\circ}\text{C}$ ($68\pm 6^{\circ}\text{F}$) and $65\pm 3\%$ relative humidity.

7.18.3 Test procedure

Concentrated static load – Procedures of ASTM E-661 and Section 7.1 of PS 2 shall be followed except that:

1. The specimen shall be placed in the test frame with the subject knot or knothole in the tension zone when a bending load is applied.
2. The load shall be applied over the subject knot or knothole on the face opposite the knot or knothole.

Concentrated impact load – Procedures of ASTM E-661 and Section 7.1 of PS 2 shall be followed, except that:

1. The specimen shall be placed in the test frame with the subject knot or knothole in tension.
2. The impact shot bag shall be dropped once from a height of 760 mm (30 in.).
3. The shot bag shall be dropped over the subject knot or knothole on the face opposite the knot or knothole.

7.19 Radial probe test

7.19.1 General

This method defines a procedure for determining delamination associated with knots and knotholes in plywood panels.

7.19.2 Equipment

The probe used shall measure 6.4 mm (1/4 in.) wide at the tip by 0.3 mm (0.012 in.) thick and shall increase in thickness to about 0.6 mm (0.025 in.), 12 mm (1/2 in.) from the tip. The 6.4 mm (1/4 in.) width shall increase to a width of 16 mm (5/8 in.) at 25 mm (1 in.) from the tip. The probe is to be of any convenient length. The tip of the probe shall be squared off and not sharp so that when probing delaminations, fibers across the delaminated area will not be cut. In addition, the probe shall be fitted with a mechanism that is capable of limiting the force to the maximum level specified.

7.19.3 Specimen preparation

One knot or knothole per sample panel shall be selected. The knot or knothole selected shall be the maximum size (+0, -13 mm [+0, -1/2 in.]) permitted within the grade. Each specimen shall be cut 300 x 300 mm (12 x 12 in.) with the knot or knothole approximately centered.

Specimens shall be moisture cycled and redried according to one of the following three cycles:

1. The 72-hour water spray cycle specified in Section 7.18. After exposure, specimens shall be redried until constant weight is reached at 20±3°C (68±6°F) and 65±3% relative humidity.
2. The 72-hour water soak cycle specified in Section 7.18 (as an alternative to the 72-hour water spray cycle). After exposure, specimens shall be redried until constant weight (weight change ≤ 0.2% within 2 hours) is reached at 20±3°C (68±6°F) and 65±3% relative humidity.
3. Specimens shall be placed in a pressure cylinder, flooded with water at 49±6°C (120 ±10°F) and subjected to a vacuum of 91±7 kPa (27±2 in. of mercury) for 3 hours. Specimens shall then be subjected to 3 hours of pressure not to exceed 414 kPa (60 psi). This shall be followed by a second vacuum exposure of 91±7 kPa (27±2 in. of mercury) for 2 hours. After exposure, the specimens shall be redried until constant weight (weight change ≤ 0.2% within 2 hours) is reached at 20±3°C (68±6°F) and 65±3% relative humidity.

7.19.4 Test procedure

Each specimen shall be cut into 8 sectors with radii intersecting at center of knot or knothole. The area surrounding the knot or knothole shall be visually inspected for delamination. Where separations are visible, the probe shall be inserted with a force of 35.5±4.5 N (8±1 lbf). No prying action or lateral movement shall be applied.

For each sector, the radial distance from the tip of the sector to the boundary of separation beyond the knot or knothole shall be measured along both edges of the sector and recorded. Where a separation is not found, the distance from the tip of the sector to the boundary of the knot or knothole shall be measured and recorded.

The total area of separation for each specimen shall be calculated as:

$$A = \pi R^2$$

where: A = total area of separation (mm² or in.²)
R = average radius of separation, calculated as the average of 16 distances (measured at edges of sectors) from the tips of the sectors to either the boundary of separation or the boundary of the knot or knothole (mm or in.).

7.20 Dead weight stiffness capacity (EI) test (non-mandatory)

7.20.1 General

This procedure provides an estimate of full panel stiffness capacity. Dead weight stiffness is not a requirement.

7.20.2 Equipment

Sawhorses may be used for support, but the metal frame shown in Figure 6 is recommended. The supports shall be at least 1,220 mm (48 in.) wide, fixed to the floor or weighted, level and parallel to each other. The deflection gauge shall have a range of 0 to 50 mm (0 to 2 in.) and be graduated in 0.025 mm (0.001 in.) increments. Loading bars shall be 1,220 mm (48 in.) long and 25 to 38 mm (1 to 1.5 in.) wide. The weight of the bars shall be determined to the nearest 0.5 N (0.1 lb). Load bars are typically in the range of 44.5, 89.0 and 178.0 N (10, 20 and 40 lb).

Figure 6. Steel Test Frame for Dead Weight Stiffness Test

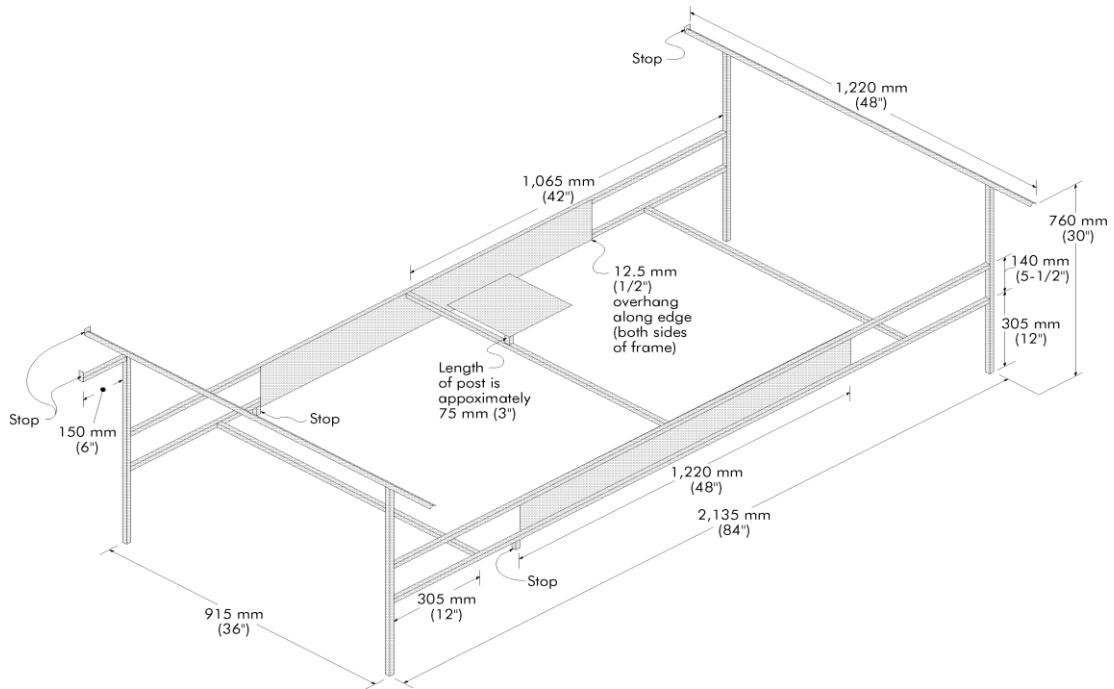

7.20.3 Specimen preparation

The number of samples will be prescribed by the certification agency. When measuring stiffness parallel to the strength axis, 1,220 x 2,440 mm (48 x 96 in.) panels shall be tested. Other lengths are allowable when measuring stiffness perpendicular to the strength axis. It may be useful to mark lines across the panel back at 1,220 mm (4 ft) width at 150 mm (6 in.) from either end and across the panel top at mid-length (Figure 7). On the bottom side, also mark an "X" at the panel's center.

Figure 7. Panel Alignment Marks

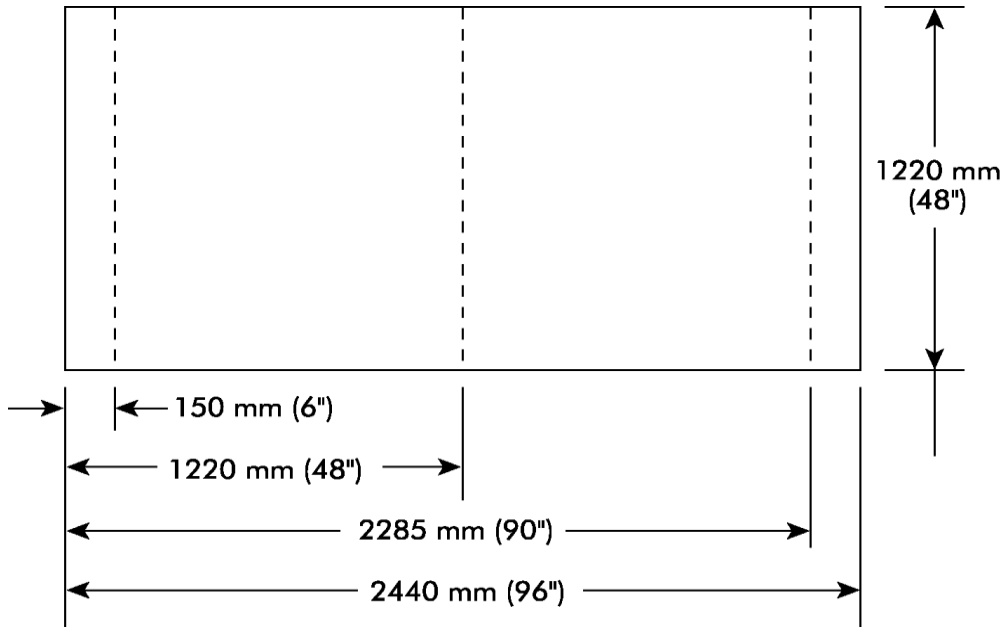

On the reverse side of the panel, mark an "X" at the panel's center:

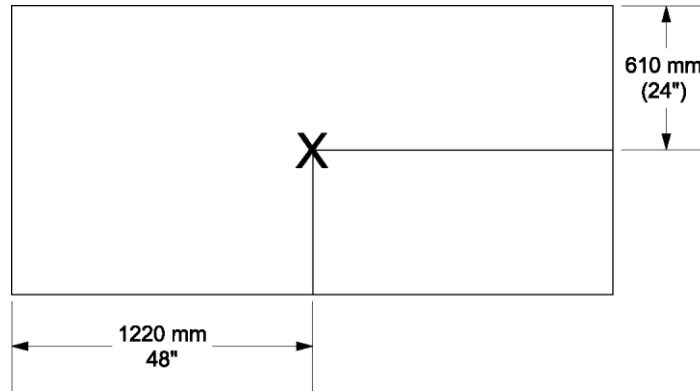

7.20.4 Test procedure

The typical span for testing the 2,400 mm (96 in.) axis shall be 2,135 mm (84 in.) and 915 mm (36 in.) for the 1,220 mm (48 in.) axis. Place the panel on top of the supports and align it so the ends are parallel to the supports, with equal length of panel overhanging each support. The lines drawn on the panel should be useful for alignment. Place the surface up, in accordance with the manufacturer's use recommendations. The deflection gauge should be placed under the panel in an adjustable fixture, perpendicular to the panel and with the tip of the gauge directly under the "x" (see Section 7.20.3).

Place load bars at mid-span, parallel to the supports. Preloads are applied first to settle the panel, removing the possible effects of warp, and should result in complete contact of the panel across the support. Discard excessively warped panels. Preloads of 44.5 N (10 lb) are recommended for panels with Performance Category between 3/8 and 7/16 and 89.0 N (20 lb) for panels with Performance Category greater than 15/32.

Record the deflections to the nearest 0.025 mm (0.001 in.). In order to obtain accurate stiffness capacity, the difference between the preload and the final load deflections should be in the range of 6.4 to 8.9 mm (0.25 to 0.35 in.) for panels with Performance Category of 3/4 or less. Panels with a Performance Category of greater than 3/4 should have sufficient weight to result in 5 mm (0.2 in.) deflection and may be cut to 610 mm (24 in.) width to accommodate deflection requirements.

Performance Category	Pre-load		Test Load		Test Span			
					Along Strength Axis		Across Strength Axis	
	N	lb	N	lb	mm	in.	mm	in.
3/8, 7/16	44.5	10	44.5	10	2,135	84	915	36
15/32 – 5/8	89.0	20	89.0	20	2,135	84	915	36
23/32 – 7/8	89.0	20	178.0	40	2,135	84	915	36
Greater than 7/8	89.0	20	*	*	2,135	84	915	36

*If larger weights are not available and deflection is less than recommended, it may be appropriate to reduce the panel width (e.g., from 1,220 mm [48 in.] to 610 mm [24 in.]

Two people should always be involved because of the need for immediate deflection readings after applying the preload and final load. The gauge shall be read immediately after application of the preload bar. Apply additional load(s) after reading the preload deflection. Record the second deflection reading immediately after applying the final load bar.

The general equation for calculating dead weight stiffness is:

$$EI = \frac{(P_2 - P_1) \times \lambda^3}{K \times b \times (D_2 - D_1)}$$

where: EI = Panel stiffness, N-mm²/mm (lbf-in.²/ft)
P₁ = Pre-load, N (lbf)
P₂ = Total load, N (lbf)
λ = Span, mm (in.)
b = Width, mm (in.)
D₁ = Deflection after preload, mm (in.)
D₂ = Deflection after final load, mm (in.)
K = Constant (48 when b is measured in mm,
4 when b is measured in inches)

8 TRADEMARKING AND CERTIFICATION

8.1 Certification

Panels represented as conforming to this Standard shall bear the stamp of a qualified inspection and testing agency which (1) inspects the manufacture (with adequate sampling, testing and examination for quality) or (2) has tested a randomized sampling of the finished panels in the shipment being certified for conformance with this Standard.

8.2 Qualified inspection and testing agency

A qualified inspection and testing agency is defined as one that:

- (a) has the facilities and trained technical personnel to verify that the grading, measuring, species, construction, sanding, bonding, workmanship, and other characteristics of the products as determined by inspection, sampling and testing conform to all of the applicable requirements specified herein;
- (b) has developed procedures to be followed by agency personnel in performance of inspection and testing;
- (c) has no financial interest in, or is not financially dependent upon, any single company manufacturing the product being inspected or tested; and
- (d) is not owned, operated or controlled by any such company.

8.3 Panel marking

All Sheathing, Structural I Sheathing and Single Floor panels represented as conforming to this Standard shall be identified with a mark bearing the grade name appropriate under these specifications, and a mark of a qualified inspection and testing agency. If identified by such a mark, the product specification shall be available from the qualified inspection and testing agency whose mark appears on the panel. The panel grade, span rating, bond classification and the symbol PS 2-10 signifying conformance to this Standard shall be included in the trademark. Any supplemental application specifications of the manufacturer shall be clearly marked on each panel. Mat-formed panels with oriented furnish shall be marked to show the direction of the strength axis. The panel fractional Performance Category (see Section 5.2.1.2) and term "Performance Category" or abbreviation (i.e., PERF CAT, CAT or Category) shall be labeled on the panel. In addition, the thickness in 1000ths of an inch within the permitted tolerance (see Section 5.2.1.2) for the Performance Category shall be labeled on the panel.

ADVISORY NOTE: See Appendix D for a table of recommended thickness labels.

8.3.1 Voiding marks

Panels originally marked as conforming to this Standard but subsequently rejected as not conforming thereto shall have any reference to the Standard obliterated or voided by the manufacturer as follows:

Shop panels shall be plainly identified by means of a 100 x 125 mm (4 x 5 in.) minimum size mark carrying the legend, "Shop-cutting panel – all other [agency] marks void." (See definition of shop-cutting panel.)

No reference shall be made to this Standard in the certification or trademarking of panels not conforming to all of the applicable provisions of this Standard.

9 EFFECTIVE DATE AND IDENTIFICATION

The PS 2 Standing Committee revised, approved and submitted this standard for public review on September 1, 2010. Upon completion of the public review, the standard became effective on June 1, 2011. As of that date, reference to this Standard is permitted in contracts, codes, advertising, invoices, product labels, and the like; however, a product shall not be advertised nor represented in any manner that in any way might imply approval or endorsement of that product by the National Institute of Standards and Technology and/or the U.S. Department of Commerce.

The following suggested statements are permitted in representing products as conforming to the requirements of this Standard:

- "This [e.g. *panel*, *shipment*] conforms to all requirements established in Voluntary Product Standard PS 2-10, 'Performance Standard for Wood-Based Structural-Use Panels,' in accordance with the U.S. Department of Commerce Procedures for the Development of Voluntary Product Standards. Full responsibility for the conformance of this product to the Standard is assumed by (name and address of producer and/or distributor)."
- "Conforms to Voluntary Product Standard PS 2-10, (name and address of producer and/or distributor)."

10 STANDING COMMITTEE

A Standing Committee has been appointed to assist in keeping this Standard current. The names of the members of the Committee are available from the Secretariat for this Committee: the Standards Services Division, National Institute of Standards and Technology, 100 Bureau Drive, MS 2150, Gaithersburg, Maryland 20899-2150, website: ts.nist.gov/sccg.

Issues regarding interpretation or implementation of the Standard and third-party quality assurance policies and procedures shall be considered by a Standard Implementation Review Subcommittee as appointed by the Standing Committee. A request to consider such issues shall be made in writing to the Secretariat of the Standing Committee (NIST), who will bring it to the attention of the Standing Committee. Formal operating procedures developed for the Subcommittee shall be subject to approval by NIST. Any recommended actions by the Subcommittee will be reported to the Standing Committee for their consideration and action.

APPENDIX A. (Nonmandatory)

A1 SHIPMENT REINSPECTION PRACTICES

A1.1 General

This information is based on industry practice and is offered to structural-use panel purchasers.

A1.2 Request for reinspection

Any request by the buyer for the reinspection of any item or lot of panels certified as conforming to this Standard shall be directed to the seller. Lacking agreement of the buyer and seller as to the settlement of a complaint, the purchase, sale or shipment of panels certified as conforming to this Standard shall be construed as involving agreement to submit such panels to reinspection by the qualified inspection and testing agency whose trademark was used.

A1.3 Responsibility of the buyer

A request to the seller for reinspection is permitted:

- a. for panel grade – within 30 days⁶ after arrival at the first point of receipt from the mill, if the grade of any item, as invoiced, is in doubt;
- b. for glue bond quality of Exterior panels – when delamination is visibly evident;
- c. for bond quality and bond performance associated with knots and knotholes of Exposure 1 panels – within 6 months after arrival at first point of receipt from the mill, if delamination is visibly evident;
- d. for structural performance, such as resistance to concentrated loads on panels – within 6 months after arrival at first point of receipt from the mill;
- e. for physical properties, such as linear expansion of panels – within 6 months after arrival at first point of receipt from the mill.

All panels of disputed grade shall be kept intact and properly protected from damage, deterioration and from direct exposure to moisture which could interfere with a fair reinspection.

All panels of disputed quality shall be held for a period not to exceed 30 days after the date of request for reinspection. Use by the buyer of any or all of the disputed stock within the 30-day period shall constitute an acceptance of the used portion.

A1.4 Responsibility of the seller

A request for reinspection shall be promptly acknowledged by the seller following its receipt.

A1.5 Cost and assistance

The expense of reinspection shall be borne by the seller if the item, lot or shipment in dispute fails to pass the reinspection as provided for in A1.6. If the panels pass the reinspection, said expenses shall be borne by the buyer. The buyer shall lend all reasonable assistance to facilitate the reinspection.

A1.6 Reinspection procedures and settlement

A1.6.1 Condition of panels

All panels designated as complying with this Standard shall be subject to reinspection in the as-manufactured condition only. This requirement does not apply to reinspections for bond quality.

A1.6.2 Sampling for panel grade, size and thickness reinspections

At buyer's or seller's option, grade, size and thickness reinspections may include all panels of an item whose conformance to this Standard is in dispute. However, buyer and seller may agree upon a reduced basis for sampling provided at least 20% or 300 panels, whichever is smaller and which represents only those items as invoiced which are in dispute, are reinspected for conformance. For reduced sampling, the quantity of panels selected from each disputed

⁶ For unitized shipments, the 30-day limit shall be extended to include the period dating from receipt of shipment to breaking of the first bundle, but not exceeding 6 months, provided the requirement for keeping the disputed panels intact is observed and the panels in question are held for at least 30 days following the request for reinspection.

item shall be prorated according to the number of panels included in each item as invoiced. Panels found to be below grade or out of tolerance for size and thickness shall have improper trademarks obliterated and shall be re-marked with appropriate designation with a special inspection mark registered by the qualified agency conducting the reinspection and applied by that agency's authorized representative.

A1.6.3 Panel grade, size and thickness reinspections

If reinspection establishes that a disputed item is more than 5% below grade or out of dimensional tolerance for the product description as invoiced, that item fails to pass the reinspection and the nonconforming panels need not be accepted. If reinspection establishes that a disputed item is 5% or less below grade or out of dimensional tolerance, it passes the reinspection and the disposition of the nonconforming panels shall be as agreed upon between the buyer and seller. In addition to the above 5% grade and dimensional tolerance, a 5% tolerance shall apply separately to the inner ply gap limitations, including the limitations applicable to plugged crossbands and jointed crossbands, as set forth in PS 1.

A1.6.4 Sampling for bond quality, bond performance associated with knots and knotholes, structural performance or physical properties reinspections

For test purposes, 20 panels, or 5% of the panels, whichever is less, shall be selected at random from the item, lot or shipment which is in dispute. The number of panels required shall be calculated by applying the "percent panels" to the lot size and converting part panels to whole panels by using a rounding procedure where 0.01 to 0.49 parts are considered to be the smaller whole number, while 0.50 to 0.99 parts are considered to be the larger whole number. These panels shall be selected from locations distributed as widely as practicable throughout the material being sampled. When an item, lot or shipment involves panels with different bond requirements, testing and evaluation shall apply separately to each category.

A1.6.5 Bond quality reinspections

Reinspection of the unused panels in the disputed item, lot or shipment shall be carried out following the procedures set forth in Sections 7 and A1.6.4 above. If the reinspection tests establish that the glue bond quality does not meet the requirements of Section 6.2.4 as applicable, the item, lot or shipment fails to pass the reinspection and may be rejected by the buyer. If the glue bond quality requirements are met, the item, lot or shipment passes the reinspection, and the buyer shall accept the item, lot or shipment as invoiced, except that the buyer need not accept any delaminated Exterior panels.

A1.6.6 Reinspection for bond performance associated with knots and knotholes

Unless otherwise agreed upon between buyer and seller, reinspections for bond performance associated with knots and knotholes shall be limited to knots and knotholes greater than 50 mm (2 in.) but not exceeding 76 mm (3 in.) in width measured across the grain. Knots and knotholes within this range shall be reinspected according to Sections 7.18 and 7.19. If the panels were not exposed to weather prior to reinspection sampling, they shall be moisture conditioned according to the cycle specified in Sections 7.18 and 7.19 prior to reinspection.

If reinspection tests establish that the bond performance associated with knots and knotholes requirements are not met, the item, lot or shipment fails to pass the reinspection and may be rejected by the buyer. If the reinspection requirements are met, the item, lot or shipment passes the reinspection and the disposition of the nonconforming panels shall be as agreed upon between the buyer and seller.

A1.6.7 Structural performance reinspections

Unless otherwise agreed upon between buyer and seller, structural performance reinspections are limited to concentrated loads (Section 5.3.1.1). If the buyer and seller agree to additional tests, a larger number of panels than those given in Section A1.6.4 may be needed. If the reinspection tests establish that the concentrated load requirements are not met, the item, lot or shipment fails to pass the reinspection and may be rejected by the buyer. If the concentrated load requirements are met, the item, lot or shipment passes the reinspection and the disposition of the nonconforming panels shall be as agreed upon between the buyer and seller.

A1.6.8 Physical property reinspections

Unless otherwise agreed upon between buyer and seller, physical property reinspections shall be limited to linear expansion (Section 5.3.2.1). If the reinspection tests establish that the linear expansion requirements are not met, the item, lot or shipment fails to pass the reinspection and may be rejected by the buyer. If the linear expansion requirements are met, the item, lot or shipment passes the reinspection and the disposition of the nonconforming panels shall be as agreed upon between the buyer and seller.

Reinspection Flow Chart

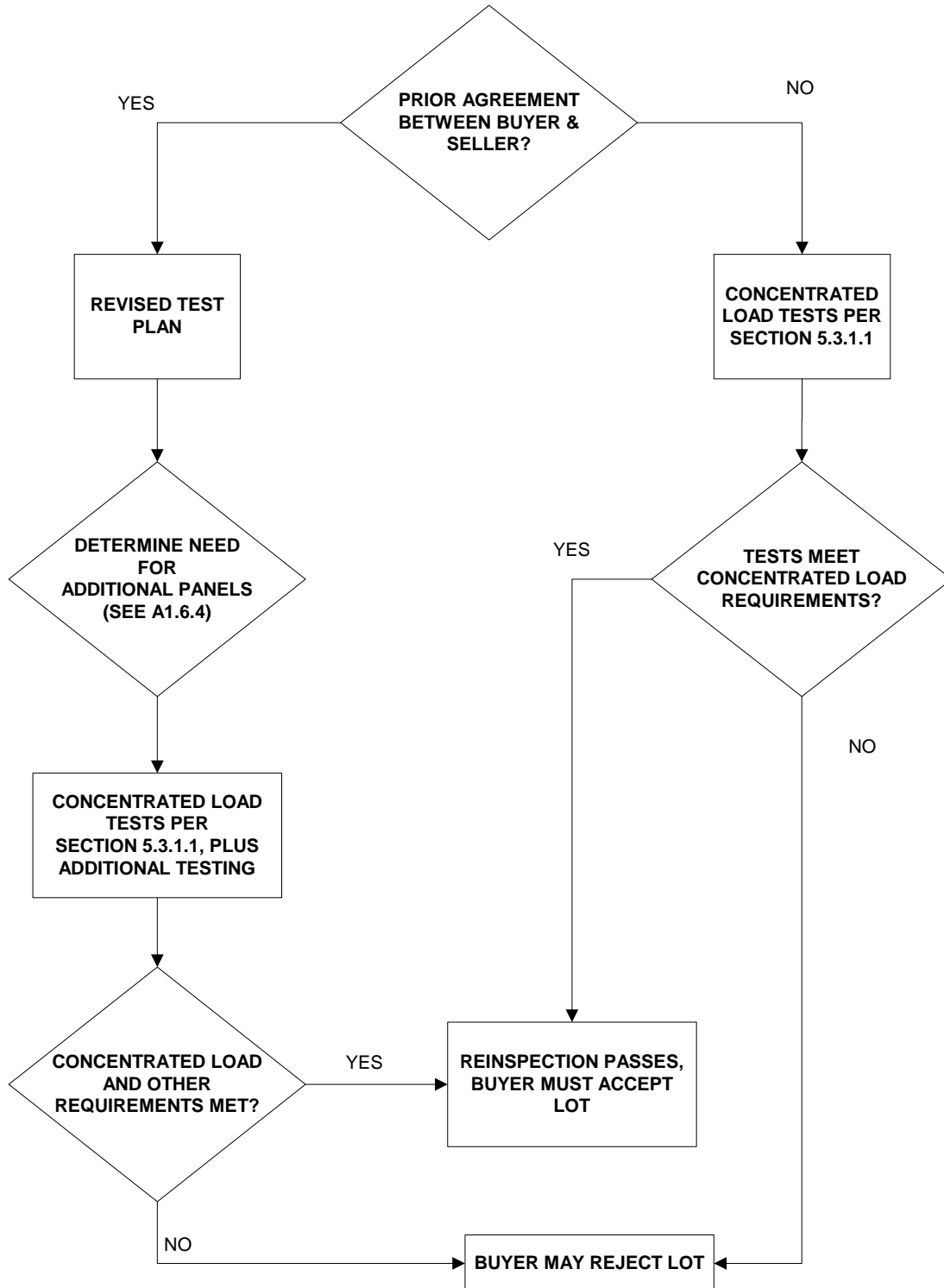

APPENDIX B. (Nonmandatory)

PS 2 Qualification Flow Chart

**PERFORMANCE-RATED PANEL QUALIFICATION
FOR
ROOF, SUBFLOOR, SINGLE FLOOR AND WALL APPLICATIONS**

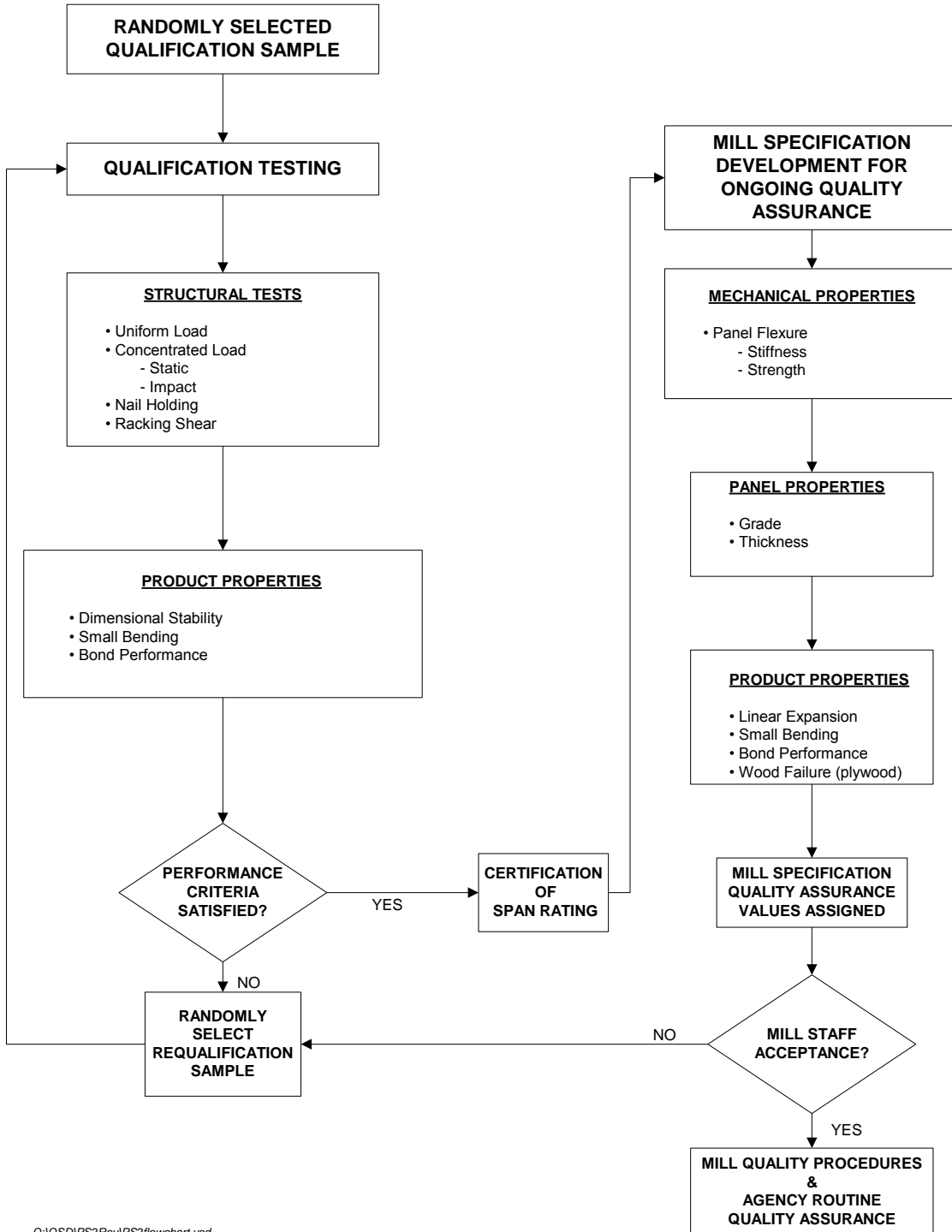

Q:\QSD\PS2 Rev\PS2\flowchart.vsd

APPENDIX C. (Nonmandatory)

History of the Standard and Comments on the Current Edition

C1 History of PS 2

In September 1988, a special Bi-national Committee (BNC) was formed and charged with the task of fostering the mutual objective of the United States and Canada with respect to the development and implementation of harmonized standards with regard to performance requirements for plywood. This action was a consequence of the implementation of the Free Trade Agreement (FTA) of 1987. In accordance with the Agreement, U.S. tariffs on plywood and other structural panels could not be removed until the trade issues involving plywood standards were resolved. Of concern to the United States was the fact that certain grades of plywood permitted in PS 1 were not covered in Canadian plywood standards; and, consequently, not acceptable under Canadian building codes.

The BNC began its task by reviewing the existing industry standard APA – *The Engineered Wood Association* (APA), APA PRP-108, Performance Standards and Policies for Structural-Use Panels, and the Canadian Standards Association (CSA) standard CAN/CSA-O325, Construction Sheathing, to identify the technical differences and to consider the roles the standards might play in resolving the plywood trade issues. It concluded that the development of common criteria embodied in performance-based national standards offered means to resolve the trade issue.

Next, the BNC sponsored a joint U.S./Canadian study designed to produce additional comparative information on U.S. and Canadian plywood. Based on BNC's assessment of the technical differences in the APA and CSA standards and the data derived from the joint study, the BNC in November 1990 submitted new U.S. and Canadian draft standards, respectively, to the National Institute of Standards and Technology (NIST) in the United States and the CSA in Canada for processing as national consensus standards.

In March 1991, APA signed an agreement with NIST to support development of the proposed U.S. performance standard as a Voluntary Product Standard (VPS) under procedures of the U.S. Department of Commerce. In April 1991, NIST established a Standard Review Committee under the VPS Program to assume responsibility for development of the U.S. standard. On October 15, 1991, after two 30-day review periods and some editorial changes, the Committee recommended unanimously that the proposed standard be prepared for public review and acceptance as a Voluntary Product Standard.

In March 1992, the proposed VPS standard was distributed to a list of manufacturers, distributors, consumers and others who might have interest in the subject standard, and on April 8, 1992, NIST announced in the Federal Register the public circulation of the proposed standard and invited public comments. A 75-day comment period was allowed. Following public review of the standard, which ended June 22, 1992, NIST determined that the responses indicated consensus among producers, distributors and consumers in accordance with the published procedures. The standard was originally approved for publication by NIST as Voluntary Product Standard PS 2-92, Performance Standard for Wood-Based Structural-Use Panels, on August 27, 1992.

The new U.S. standard was not intended to replace existing standards such as Voluntary Product Standard PS 1-83, Construction and Industrial Plywood, but to serve as an alternative performance-based standard that would relate to a variety of forms of structural panels: plywood, oriented strand board, waferboard, structural particleboard, and composite panels.

C2 Edition PS 2-04

After considerable technical review, PS 2-04 was revised and accepted in December 2004. The PS 2-04 edition contained many revisions. The major technical revisions included the following.

C2.1 Revision to Exposure 1 bond performance methods

This edition of the standard introduced a new method for determining Exposure 1 bond performance for mat formed panels. As an alternate to using the 1 inch by 5 inch edge wise bending method, stiffness and strength criteria based on larger flatwise bending specimens were introduced.

C2.2 Linear expansion method

Revisions to the linear expansion method were made based on a need to reflect industry performance and serviceability requirements. Industry samples were benchmarked for linear expansion, and a suitable cycle and criteria were evaluated. The criterion was established at an average level, which is common for serviceability applications. The cycle was based on equilibrium at 50% relative humidity, which is viewed to be more representative of installed conditions than the oven-dry condition. Industry surveys were conducted and reviewed to determine acceptable performance using the revised criteria, and test methods and verification of the methods was conducted on a representative subset of products.

C2.3 Pass/fail provisions for structural performance

General comments on the structural performance sections indicated the instructions were not as clear as they could be and even sometimes in conflict. In addition, concerns were expressed about applying structural performance criteria to daily mill quality assurance evaluations. Finally, there were questions about the linearity of deflection requirements for a given increase in spans. The following changes were made:

- a. Revisions to the sections describe the test provisions more clearly. Each possible scenario is described independently. The actual percentage resulting in passing results is specified for each test and criterion explicitly.
- b. Where appropriate, a clause was added to each performance test stating that the average of the tests should meet the designated requirement.

C2.4 Exposure 2

This exposure classification was deleted due to the lack of use by the industry.

C2.5 Stability Index

The stability index was deleted due to the use of linear expansion as the primary method to determine dimensional stability.

C3 Current edition, PS 2-10

After considerable technical review by members of the PS 2 Standing Committee, the standard was revised to address the following technical and informational aspects.

C3.1 Labeling of panel thickness

In response to consumer complaints regarding panel thickness tolerances that created the potential for labeling being out of compliance with NIST Handbook 130 and 133, the standard was revised to create a Performance Category based on customary thickness notations used in U.S. model building codes. In addition, panel labeling requirements were changed to require the Performance Category and decimal thickness representation.

C3.2 Formaldehyde appendix

In response to national and international regulations of formaldehyde emissions from some wood products, an informational appendix was added to review those regulations with respect to PS 2 panels.

C3.3 Environmental attributes and green building rating systems.

An informational appendix was added to review environmental attributes of PS 2 panels with respect to various green building rating systems.

C3.4 Technical revisions.

A review of technical provisions and terminology led to various changes to reflect industry practice. These included revisions to clarify the dry test condition and the “20” span rating. Fastener load values were modified to better reflect panel performance characteristics and to respond to increased code provisions for fastening requirements.

APPENDIX D. (Nonmandatory)
Recommended Thickness Labels

D1 Recommended thickness labels

Section 5.2.1.2 specifies thickness tolerances and Performance Categories for panels. Section 8.3 specifies that the panels shall be labeled with a thickness label in 1000ths of an inch and that labeled quantity shall be within the minimum and maximum thickness specification for that Performance Category. Table D1 presents recommended thickness labels.

D2 Regulations on labeling

See Appendix E for discussion of regulations dealing with labeling.

TABLE D1. RECOMMENDED THICKNESS LABELING FOR PANELS

Performance Category ²	Thickness Requirements for Panels ¹		
	Minimum Thickness in. (mm)	Maximum Thickness in. (mm)	Recommended Thickness Label ⁽³⁾
1/4 PERF CAT	0.219 (5.56)	0.281 (7.14)	Thickness 0.225 IN.
5/16 PERF CAT	0.281 (7.14)	0.344 (8.73)	Thickness 0.289 IN.
11/32 PERF CAT	0.313 (7.94)	0.375 (9.53)	Thickness 0.322 IN.
3/8 PERF CAT	0.344 (8.73)	0.406 (10.32)	Thickness 0.354 IN.
7/16 PERF CAT	0.406 (10.32)	0.469 (11.91)	Thickness 0.418 IN.
15/32 PERF CAT	0.438 (11.11)	0.500 (12.70)	Thickness 0.451 IN.
1/2 PERF CAT	0.469 (11.91)	0.531 (13.49)	Thickness 0.483 IN.
9/16 PERF CAT	0.531 (13.49)	0.594 (15.08)	Thickness 0.547 IN.
19/32 PERF CAT	0.563 (14.29)	0.625 (15.88)	Thickness 0.578 IN.
5/8 PERF CAT	0.594 (15.08)	0.656 (16.67)	Thickness 0.609 IN.
23/32 PERF CAT	0.688 (17.46)	0.750 (19.05)	Thickness 0.703 IN.
3/4 PERF CAT	0.719 (18.26)	0.781 (19.84)	Thickness 0.734 IN.
13/16 PERF CAT	0.781 (19.84)	0.844 (21.43)	Thickness 0.788 IN.
7/8 PERF CAT	0.831 (21.11)	0.919 (23.34)	Thickness 0.849 IN.
1 PERF CAT	0.950 (24.13)	1.050 (26.67)	Thickness 0.970 IN.
1-1/8 PERF CAT	1.069 (27.15)	1.181 (30.00)	Thickness 1.091 IN.
1-1/4 PERF CAT	1.188 (30.16)	1.313 (33.34)	Thickness 1.213 IN.

¹Thickness requirements are based on a tolerance of +/- 0.8 mm (1/32 in.) for panels with Performance Categories of 13/16 and less and +/- 5% for panels with Performance Categories greater than 13/16 unless a closer tolerance is determined through qualification testing. Inch units are presented as primary units due to customary practice in the United States.

²Acceptable abbreviations are PERF CAT, CAT or Category.

³The panel manufacturer may label with any thickness value provided the product complies with Section 5.2.1.2. The recommended thickness label for categories less than 9/16 is 3% above the minimum. The recommended thickness label for categories greater than or equal to 9/16 are the minimum values for PS 1 sanded panels.

APPENDIX E. (Nonmandatory)

Labeling Guidelines Based on the Uniform Packaging and Labeling Regulations of NIST Handbook 130 v2009

E1 Summary

- E1.1 When intended for sale or distribution, the labeling of the panels should meet the requirements of the Uniform Packaging and Labeling Regulation. This section provides guidance on the requirements applicable to wood panels.

E2 Background

- E2.1 The National Institute of Standards and Technology of the U.S. Department of Commerce (“NIST”) promotes the development of standards to be applied across industry and supports the publishing of NIST Handbook 130, “Uniform Laws and Regulations in the areas of legal metrology and engine fuel quality.” NIST Handbook 130 is a compilation of the latest uniform laws and regulations regarding packaging and labeling requirements adopted by the National Conference on Weights and Measures, Inc. (“NCWM”) and is intended to represent standards to be adopted into law by the weights and measures jurisdictions of the United States.

- E2.2 Of the weights and measures jurisdictions of the United States (including, the 50 states, Washington DC, Puerto Rico and the Virgin Islands) with respect to the Uniform Packaging and Labeling Regulation, (i) 19 have adopted the most current version of NIST Handbook 130, (ii) 29 have adopted a prior version of NIST Handbook 130, (iii) four have laws and regulations in place that are not based on NIST Handbook 130 and (iv) one has no specific laws or regulations in this regard.

- E2.3 This appendix provides a summary of NIST Handbook 130 provisions relevant to wood panels, with specific references to sections of the 2009 version. This summary is not intended to be comprehensive, but is offered as guidance. For additional information, a complete copy of the most recent version of NIST Handbook 130 is available at <http://ts.nist.gov/WeightsAndMeasures/Publications>.

E3 Scope and definitions

- E3.1 Except for packages intended for export, the Uniform Packaging and Labeling Regulation of NIST Handbook 130 applies to consumer and non-consumer packages.

E3.1.1 Consumer package

“[A] package that is customarily produced or distributed for sale through retail sales agencies or instrumentalities for consumption or use by individuals for the purposes of personal care or in the performance of services ordinarily rendered in or about the household or in connection with personal possessions.” (See Section 2.2 of the Uniform Packaging and Labeling Regulation).

E3.1.2 Non-consumer package

“Any package other than a consumer package, and particularly a package intended solely for industrial or institutional use or for wholesale distribution.” (See Section 2.3 of the Uniform Packaging and Labeling Regulation.)

- E3.2 The requirements of the Uniform Packaging and Labeling Regulation set forth in NIST Handbook 130 are to be set forth generally on labels and/or principal display panels.

E3.2.1 Label

“Any written, printed, or graphic matter affixed to, applied to, attached to, blown into, formed, molded into, embossed on, or appearing upon or adjacent to a consumer commodity or a package containing any consumer commodity, for purposes of branding, identifying, or giving any information with respect to the commodity or to the contents of the package, except that an

inspector's tag or other nonpromotional matter affixed to or appearing upon a consumer commodity shall not be considered a label requiring the repetition of label information required by this regulation." (See Section 2.5 of the Uniform Packaging and Labeling Regulation.)

Note: For the purpose of structural wood panels, the "label" encompasses information that is attached to or affixed to the panel or to the panel bundle prior to shipping from the mill. At the retail level, the label may encompass information that is adjacent to the panels.

E3.2.2 Principal display panel

"[t]hat part, or those parts, of a label that is, or are, so designed as to most likely be displayed, presented, shown, or examined under normal and customary conditions of display and purchase. Wherever a principal display panel appears more than once on a package, all requirements pertaining to the 'principal display panel' shall pertain to all such 'principal display panels.'" (See Section 2.7 of the Uniform Packaging and Labeling Regulation.)

E4 Declaration of identity and responsibility

E4.1 The package of wood panels must be labeled with the product identity and with the panel producer.

E4.2 Product identity

The name of the panel product should be included on the principal display panel for consumer packages and on the outside of the package for non-consumer packages. (See Sections 3.1 (consumer) and 4 (non-consumer) of the Uniform Packaging and Labeling Regulation). The product identity for consumer packages should be parallel to the base on which the package rests as it is designed to be displayed. (See Section 3.1.1 of the Uniform Packaging and Labeling Regulation.)

E4.3 Product responsibility

The company name should be included on the label of the package. (See Section 5 of the Uniform Packaging and Labeling Regulation.)

E4.3.1 The company identification on the label should include city, state and zip code of the company. (See Section 5 of the Uniform Packaging and Labeling Regulation.)

E5 Declaration of quantity

E5.1 The following guidance on Declaration of Quantity is based on the requirements for "Consumer Packages." Deviations based on "Non-Consumer Packages" are provided in [brackets].

E5.2 Quantity should be expressed in terms of count combined with appropriate declarations of the weight, measure and/or size of the individual units unless a declaration of count alone is fully informative but, if there exists a firmly established general consumer usage and trade custom with respect to the terms used in expressing a declaration of quantity of a particular commodity, such declaration of quantity may be expressed in its traditional terms if such traditional declaration gives accurate and adequate information as to the quantity of the commodity. (See Sections 6.4 and 6.4.1 of the Uniform Packaging and Labeling Regulation.) [There is no stated requirement regarding additional measurements other than count for non-consumer packaging. In other words, count or established trade custom is the requirement for non-consumer packages. (See Section 7.3 of the Uniform Packaging and Labeling Regulation.)]

E5.3 General Rules

E5.3.1 The size quantity declaration must be expressed in metric system units (meter (m), centimeter (cm) or millimeter (mm)) and in inch-pound system units (yard (Yd), foot (ft), inch (in.)). (See Sections 6.1 (Note 3), 6.5, 6.5.1, 6.7 and 6.7.1 of the Uniform Packaging and Labeling Regulation.) [The same rules apply to non-consumer packages except that either or both the metric system units and the inch-pound system units may be used. (See Sections 7.1 (Note 6), 7.4, 7.4.1, 7.5 and 7.5.1 of the Uniform Packaging and Labeling Regulation.)]

X5.3.2 The size quantity should be expressed in terms of the largest whole unit. (See Section 6.2 of the Uniform Packaging and Labeling Regulation.) [The same rules apply to non-consumer packages. See Section 7.2 of the Uniform Packaging and Labeling Regulation.]

- Remainders for the metric system units should be expressed as decimals. (See Section 6.2 of the Uniform Packaging and Labeling Regulation). [The same rules apply to non-consumer packages. See Section 7.2 of the Uniform Packaging and Labeling Regulation.]
- If less than 1 m, then length measure is expressed in terms of cm or mm. See Section 6.6.1(a) of the Uniform Packaging and Labeling Regulation. [No comparable rules for non-consumer.]
- If greater than 1 m, then length is expressed in m with decimal fractions. See Section 6.6.2(a) of the Uniform Packaging and Labeling Regulation. [No comparable rules for non-consumer.]
- Metric system measurements should go 3 digits out except where the quantity is below 100 mm or cm, where it may be shown in 2 digits. In any case, any final zero appearing to the right of the decimal point need not be shown. See Section 6.5(g) of the Uniform Packaging and Labeling Regulation. [Same rules for non-consumer packages. See Section 7.4 of the Uniform Packaging and Labeling Regulation.]
- Remainders for the inch-pound system units should be expressed in common fractions or decimal fractions of the largest whole unit or in the next smaller whole unit with any further remainder in terms of common or decimal fractions of the smallest unit present. See Section 6.2 of the Uniform Packaging and Labeling Regulation. [Same rules for non-consumer packages. See Section 7.2 of the Uniform Packaging and Labeling Regulation.]
- If less than 1 ft, then length is expressed in terms of in. See Section 6.8.1(a) of the Uniform Packaging and Labeling Regulation. [No comparable rules for non-consumer.]
- If greater than 1 ft, then length is expressed in terms of the largest whole unit (Yd or ft) with any remainder expressed in inches and fractions of the inch or in fractions of the ft or Yd, except that it shall be optional to include a statement of length in terms of inches. See Section 6.8.2(a) of the Uniform Packaging and Labeling Regulation. [No comparable rules for non-consumer.]
- A common fraction is reduced to its lowest term. A decimal fraction shall not be carried out more than 3 decimal places. See Section 6.11 of the Uniform Packaging and Labeling Regulation. [No comparable rules for non-consumer.]

E5.3.2. Rules specific to bi-dimensional commodities [No comparable rules for non-consumer.]

- Must be expressed in both metric and inch-pound units. No declaration of area is required for commodities for which the length and width measurements are critical in terms of end use if such commodities clearly present the length and width measurements on the label. (See Section 6.9 of the Uniform Packaging and Labeling Regulation).
- If the area is 37.1 dm^2 (4 ft^2) or more, in terms of the length and width, in terms of the largest whole unit, provided bi-dimensional commodities with a width of 10 cm (4 in.) or less, the inch-pound statement of width shall be expressed in terms of linear inches and fractions thereof, and length shall be expressed in the largest whole unit (yard or foot) with any remainder in terms of fractions of the yard or foot, except that it shall be optional to express the length in the largest whole unit followed by a statement of length in inches or to express the length in inches followed by a statement of length in the largest whole unit. An inch-pound dimension of less than 2 ft may be stated in inches. (See Section 6.9(c) of the Uniform Packaging and Labeling Regulation).

Examples:

5 cm x 9.14 m (2 in. x 10 yd), or

5 cm x 9.14 m (2 in. x 10 yd) (360 in.), or

5 cm x 9.14 m (2 in. x 360 in.) (10 yd)

E5.3.3 The required quantity declaration may be supplemented by one or more declarations of weight, measure, or count, such declaration appearing other than on a principal display panel. Such supplemental statement of quantity of contents shall not include any term qualifying a unit of weight, measure, or count that tends to exaggerate the amount of commodity contained in the package (e.g., “giant” quart, “larger” liter, “full” gallon, “when packed,” “minimum,” or words of similar import.) (See Section 6.12 of the Uniform Packaging and Labeling Regulation). *[No such provision applies to non-consumer packages.]*

E5.3.4 In no event, may any declaration of quantity be qualified by the addition of the words “when packed,” “minimum,” or “not less than” or any words of similar import (e.g., “approximately”), nor shall any unit of weight, measure, or count be qualified by any term (such as “jumbo,” “giant,” “full,” or the like) that tends to exaggerate the amount of commodity. (See Section 6.14 of the Uniform Packaging and Labeling Regulation.) *[No such provision applies to non-consumer packages.]*

E6 Prominence and placement

E6.1 General

All information required to appear on a consumer package shall appear thereon in the English language and shall be prominent, definite, plain, and conspicuous as to size and style of letters and numbers and as to color of letters and numbers in contrast to color of background. Any required information that is either in hand lettering or hand script shall be entirely clear and equal to printing in legibility. (See Section 8.11 of the Uniform Packaging and Labeling Regulation.) [All information required to appear on a non-consumer package shall be definitely and clearly stated thereon in the English language. Any required information that is either in hand lettering or hand script shall be entirely clear and equal to printing in legibility. (See Section 9.1 of the Uniform Packaging and Labeling Regulation.)]

E6.2 Location

The declaration or declarations of quantity of the contents of a package shall appear in the bottom 30 % of the principal display panel or panels. (See Section 8.1.1 of the Uniform Packaging and Labeling Regulation.)

E6.3 Style of type and lettering

The declaration or declarations of quantity shall be in such a style of type or lettering as to be boldly, clearly, and conspicuously presented with respect to other type, lettering, or graphic material on the package. (See Section 8.1.2 of the Uniform Packaging and Labeling Regulation.)

E6.4 Color contrast

The declaration or declarations of quantity shall be in a color that contrasts conspicuously with its background. (See Section 8.1.3 of the Uniform Packaging and Labeling Regulation.)

E6.5 Free area

The area surrounding the quantity declaration shall be free of printed information: (a) above and below, by a space equal to at least the height of the lettering in the declaration, and (b) to the left and right, by a space equal to twice the width of the letter “N” of the style and size of type used in the declaration. (See Section 8.1.4 of the Uniform Packaging and Labeling Regulation.)

E6.6 Parallel quantity declaration

The quantity declaration shall be presented in such a manner as to be generally parallel to the declaration of identity and to the base on which the package rests as it is designed to be displayed. (See Section 8.1.5 of the Uniform Packaging and Labeling Regulation.)

E6.7 Height and proportion of numbers and letters

Table 1 sets forth minimum heights of numbers and letters based upon the area of the principal display panel. The minimum height of numbers and letters for an area of 400 in² or greater is ½ in. The height of each number of a common fraction must meet ½ the minimum height standard. No number or letter may be more than 3X as high as it is wide. (See Sections 8.2.1 and 8.2.2 of the Uniform Packaging and Labeling Regulation.)

APPENDIX F. (Nonmandatory)

Wood Structural Panels as Green Building Materials

F1 Overview

There is a growing emphasis world-wide to recognize the importance of protecting the environment. This is commonly referred to as being “green” and has resulted in a need to increase the awareness of wood as an environmentally friendly or green building material. Wood structural panels, as members of the broader wood products “family” have numerous green attributes and are considered to be environmentally friendly.

F2 Green attributes of wood

Solar energy – powered by solar energy collected by the tree’s leaves, carbon dioxide extracted from the atmosphere is combined with water and nutrients absorbed through the tree’s roots to form a composite of hollow cellulose fibers bound in a matrix of lignin by photosynthesis.

Renewable – as mature trees are harvested they are replaced by younger trees and the wood resource is renewed. This natural renewal can continue indefinitely as long as there is an ample source of water, carbon dioxide and sunlight.

Sustainable – through responsible forest management the forest resource can be sustained at levels far exceeding their harvesting. Responsible forest management is the key to minimizing adverse environmental impacts associated with the extraction of timber from forests. (Society of American Foresters (SAF), www.safnet.org)

Embodied Energy – studies have shown that wood has low embodied energy compared to most other structural materials. The energy consumed in managing forests, harvesting trees, milling timber into various end products and transporting the finished wood products to job sites is relatively small. (CORRIM, www.corrim.org)

Carbon Sequestration – scientific evidence suggests that increasing levels of carbon dioxide in the atmosphere is one cause of accelerated climate change. Trees absorb CO₂ from the atmosphere through photosynthesis, storing it as carbon in their organic matter and releasing the remaining oxygen back into the atmosphere. On average a typical tree absorbs, through photosynthesis, the equivalent of 56 pounds of carbon dioxide for every cubic foot of growth, while producing the equivalent of 45 pounds of oxygen. (adapted from Edinburgh Centre for Carbon Management)

Life Cycle Assessment – Life Cycle Assessment (LCA) is important because it quantifies how a building product or system affects the environment during each phase of its life: extraction, production, installation, use and disposal or re-use. (International Organization for Standardization, ISO 14040, 14042 and 14043)

Several CORRIM reports address many of these attributes and provide extensive scientific data supporting the relatively minimal impact that producing wood products has on the environment.

F3 Sustainable forest management programs

There are four generally recognized sustainable forest management programs with the approximate amount of acres covered in North America for each shown in parentheses:

The *Canadian Standards Association* (CAN/CSA-Z809), (192 million acres) www.csa-international.org/product_areas/forest_products_marking

The *Sustainable Forestry Initiative® (SFI)*, (143 million acres) www.sfiprogram.org

The *Forest Stewardship Council (FSC)*, (82 million acres) www.fscus.org

The *American Tree Farm System (ATFS)* (27 million acres) www.treefarmssystem.org

All of these sustainable forest management programs are intended to ensure that forestry is practiced in an environmentally responsible, socially beneficial, and economically viable way.

The CSA, FSC, and SFI programs currently have criteria for on-product labeling of certified wood products. Each has a system for manufacturing facilities to track the percentage of fiber that originates from certified forests.

F4 Major green building rating systems

To account for and quantify the effects of building construction on the environment, three major green building rating systems have evolved. These are the:

Green Building Initiative (GBI) Green Globes: this is a rating system for new commercial building construction and has been approved as an ANSI Standard. www.thegbi.org

National Green Building Standard: this is a program to rate residential construction and has been approved as an ANSI Standard with ICC and NAHB jointly sponsoring the standard. www.nahbgreen.org

USGBC LEED™ which has four distinct rating programs including, LEED for New Construction; LEED™ for New Construction; LEED™ for Existing Buildings (Remodeling); LEED™ for Commercial Interiors and LEED™ for Homes. www.usgbc.org/LEED

Each of these programs considers the impact of various environmental considerations and assigns points accordingly to achieve a green rating threshold.

While there are similarities in these rating systems there are also differences that can impact the wood products industry. The GBI Green Globes and the National Green Building Standard both award points for wood being a renewable resource, for wood products harvested from any of the four forest certification programs and for using LCA to compare building materials and systems. The USGBC LEED™ program only awards points for products that are renewed within a 10 year harvest cycle thus excluding most structural wood products, only awards points for wood products manufactured from FSC certified forests and does not consider LCA as a science based evaluation tool.

APPENDIX G. (Nonmandatory)

Formaldehyde

G1 General

Formaldehyde is a simple naturally occurring chemical made of carbon, oxygen and hydrogen. It is produced by the human body and animals and plants. It is also formed by combustion and is an industrial chemical widely used in the manufacture of many consumer products. Background information on formaldehyde and health concerns related to elevated levels in indoor air can be found at www.epa.gov/iaq/formalde.html.

G2 Formaldehyde regulations

G2.1 There are no national or state regulations of formaldehyde emissions expressly stated for PS 2 structural panels. This is mainly due to the very low emission rates demonstrated by PS 2 Structural Panels.

G2.2 U.S. Department of Housing and Urban Development Rules and Regulations 24 CFR 3280 for manufactured housing includes § 3280.308 “Formaldehyde emission controls for certain wood products”, that deals with formaldehyde emissions from particleboard and plywood. The regulations establish limits for formaldehyde emission levels and ongoing evaluation requirements as follows:

(b) Product certification and continuing qualification. All plywood and particleboard materials to be installed in manufactured homes which are bonded with a resin system or coated with a surface finish containing formaldehyde, other than an exclusively phenol-formaldehyde resin system or finish, shall be certified by a nationally recognized testing laboratory as complying with paragraph (a) of this section.

PS 2 Plywood is made predominantly with phenol-formaldehyde adhesives. When made as such, it is exempt from the HUD requirements. Other PS 2 Structural Panels are not explicitly referenced in the HUD requirements.

G2.3 California Air Resources Board (CARB) Air Toxic Control Measure for Composite Wood Products (see: <http://www.arb.ca.gov/research/indoor/formaldehyde.htm>)

The CARB ATCM for Composite Wood was approved for implementation on January 1, 2009. The scope of the standard is particleboard, Medium Density Fiberboard (MDF) and hardwood plywood. Section § 93120.1 “Definitions” explicitly excludes PS 2 Structural Panels and other structural wood products from the scope of the standard as follows:

(8) “Composite wood products” means hardwood plywood, particleboard, and medium density fiberboard. “Composite wood products” does not include hardboard, structural plywood as specified in the “Voluntary Product Standard - Structural Plywood” (PS 1-07), structural panels as specified in the “Voluntary Product Standard – Performance Standard for Wood-Based Structural-Use Panels” (PS 2-04), structural composite lumber as specified in “Standard Specification for Evaluation of Structural Composite Lumber Products” (ASTM D 5456-06), oriented strand board, glued laminated timber as specified in “Structural Glued Laminated Timber” (ANSI A190.1-2002), prefabricated wood I-joists as specified in “Standard Specification for Establishing and Monitoring Structural Capacities of Prefabricated Wood I-Joists” (ASTM D 5055-05), finger-jointed lumber, or “composite wood products” used inside of new vehicles as defined in Section 430 of the California Vehicle Code (excluding recreational vehicles), railcars, boats, aerospace craft, or aircraft.

G2.4 National “Formaldehyde Standards for Composite Wood Act”

The Formaldehyde Standards for Wood Composites Act was signed into law on July 7, 2010 and goes into effect in 2013. With respect to PS 2 panels, this law is identical to the CARB ATCM for Composite Wood (see Section G2.3). PS 2 panels are exempt from the scope of the Formaldehyde Standards for Composite Wood Act.

See: <http://www.govtrack.us/congress/bill.xpd?bill=s111-1660>.

G3 Formaldehyde emission from PS 2 Structural Panels

G3.1 Information on formaldehyde emission from PS 2 panels is available from APA in report SPE-1040, "Structural Wood Panels and Formaldehyde."