



Insufficient flashing



Flashing around skylight

Item 2 Roof to Skylight Flashing – Flashing to protect sides of skylight to prevent against combustible debris ignition and embers.

Note: Selected photographs are included to illustrate each HMM hardening item. Additional vulnerabilities or hardening items may be seen in the photographs, but those are highlighted within their specific HMM item.

HMM Reference

NIST Technical Note 2205,
Roof-to-Skylight Flashing,
Table A, Item 2 (page 58)

Project: HMM House

Size: A

Scale: 1/20

Sheet: 1/1

- **Hardening Action:** Check for standard metal flashing and that no exposed wood is present, repair as necessary.
- **Applicable Conditions:** Lack of metal flashing around skylight
- **Performance Goal:** Prevent ignition of combustible skylight framing

Installation Cautions ⚠

1. Use fire resistant caulking
2. No combustible material should be exposed.

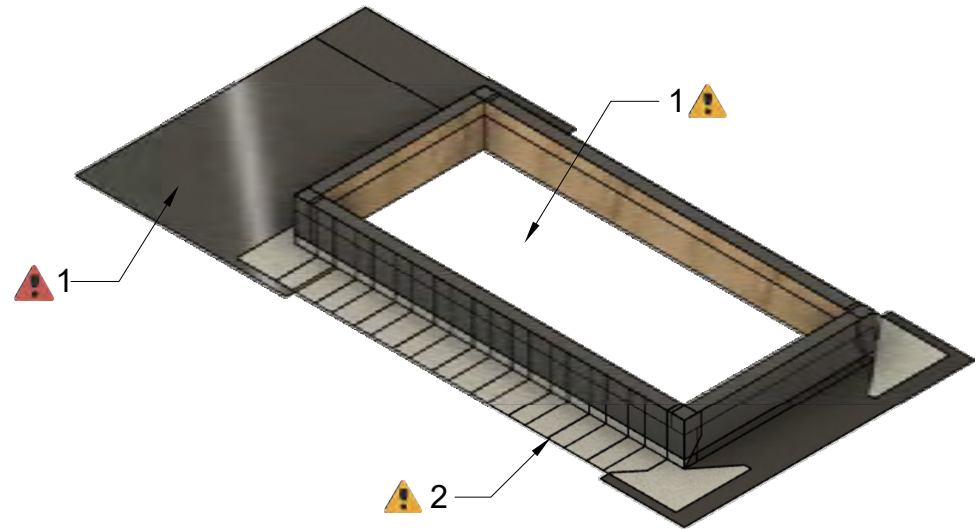
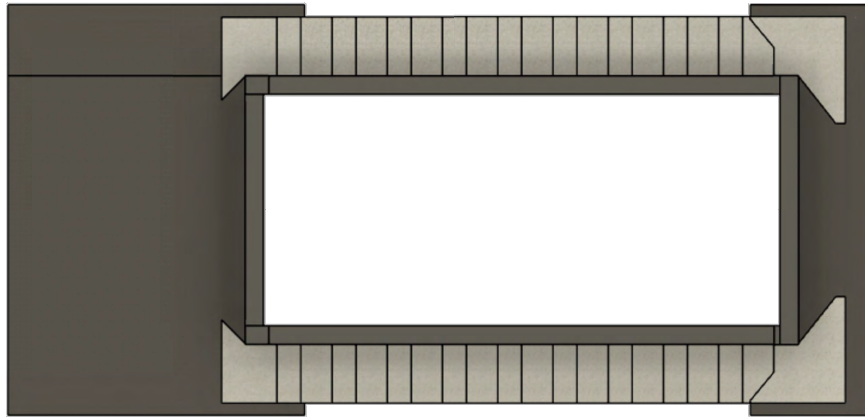

Notes

Color Key:

- Brown: wood
- Gray: Metal Step Flashing
- Black/Dark Gray: Counter Flashing

Fire Hazards ⚠

1. Debris accumulation on back or surrounding skylight panels.