

High-Voltage Impulse Testers

E.K. Howell

General Electric Company
Plainville CT

François Martzloff

General Electric Company
Schenectady NY 12345

Reprinted, with permission, from *General Electric TIS Report 75CRD039*, March 1973

Significance:

Part 5 – Monitoring instruments, laboratory measurements, and test methods

The three impulse generators described in this report were investigated as possible candidates for producing the transient waveform just then adopted for testing the emerging ground-fault circuit interrupters (GFCI) that were found to be susceptible to the oscillatory transients that had been found to be the most frequent type of transient on ac power lines (See “Res&Ind surges” in Part 3).

The third approach was eventually adopted as recommended test circuit in UL standards concerned with GFCI misoperation, and its waveform became the basis of the IEEE “Ring Wave” promulgated with IEEE Std 587TM-1980. A packaged design suitable for bench-top use was then implemented (See “TCL Generators” in this Part 3) and several units were built for GE Corporate R&D, GE operating departments, and the Underwriters Laboratories.

It should be noted that at that time, the perceived threat was the low energy-delivery capability of these oscillatory transients, not the higher energy-delivery capability of what became known as the “Combination Wave”.

TECHNICAL INFORMATION SERIES

<small>AUTHOR</small> Howell, EK* Martzloff, FD	<small>SUBJECT</small> impulse test circuits	<small>NO.</small> 75CRD039 <small>DATE</small> March 1975
<small>TITLE</small> High-Voltage Impulse Testers		<small>GE CLASS</small> 1 <small>NO. PAGES</small> 5
<small>ORIGINATING COMPONENT</small> Physics & Electronics Engineering Laboratory		<small>CORPORATE RESEARCH AND DEVELOPMENT</small> SCHENECTADY, N.Y.
<small>SUMMARY</small> <p>Design tests on various electronic appliances require to subject the test sample to voltage spikes superimposed to the 120 volt a-c line voltage.</p> <p>This report discusses three types of surge generator circuits which can be used to produce these test impulses, and gives a recommendation for a simple test circuit which can be easily built by other organizations, thereby promoting uniform performance criteria.</p> <p>The test wave shape has the rise time of a 500 kHz oscillation, followed by ringing at 100 kHz. The first peak is adjustable from 0 to 8 kV; the second is 60% of the first.</p> <p>*General Electric Circuit Protective Devices Products Department, Plainville, CT.</p>		
<small>KEY WORDS</small> surge voltages, transients, spikes, impulse, test equipment		

INFORMATION PREPARED FOR _____

Additional Hard Copies Available From

Corporate Research & Development Distribution
P.O. Box 43 Bldg. 5, Schenectady, N.Y., 12301

Microfiche Copies Available From

Technical Information Exchange
P.O. Box 43 Bldg. 5, Schenectady, N.Y., 12301

HIGH-VOLTAGE IMPULSE TESTERS

E. K. Howell and F. D. Martzloff

I. INTRODUCTION

The high-voltage impulse generators described in this report have been developed by several individuals for the purpose of simulating transient over-voltages as they occur on residential or industrial low-voltage a-c power circuits (120 or 220 volts).

Each circuit was developed on the basis of certain objectives, and consequently the designs are quite different. An evaluation and comparison has been made, from the point of view of producing a simple and economical system limited to generating the proposed "typical" surge wave shape on a 120 volt single-phase circuit. (1-3)

The objective of this test circuit is to superimpose on a 120-volt, 60 Hz power line a wave shape having a rise time to first peak of a 500 kHz wave, followed by a damped ringing at 100 kHz in which each successive peak should be about 60% of the preceding peak amplitude, the amplitude of the first peak being adjustable from 0 to 8000 volts. The source impedance for the high-voltage wave should be 50 ohms.

The three circuits are the following:

1. General-purpose ignitron switch generator, suitable for 20 kV, 20 kA pulses.
2. Specialized generator with low-voltage SCR switch and step-up pulse transformer.
3. Relay-type switch and resonant circuit (recommended circuit).

II. GENERAL-PURPOSE CIRCUIT

This circuit is assembled from available laboratory components, with an ignitron switch built especially for the purpose. (4) The circuit schematic is shown in Fig. 1. The switch is SW; the energy storage element Z_0 can be a line (cable) or capacitor bank, charged by the high-voltage supply HVDC. The surge is produced across the matching impedance R by discharging the cable when the switch is fired.

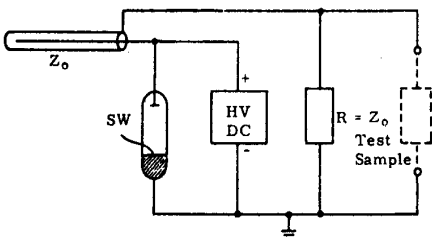

Fig. 1 Schematic diagram of surge generator.

The surges developed by this circuit can be coupled into an a-c power supply, with a suitable filter inserted between the bench supply and the receptacle where the device under test will be connected, and where the surge is injected, in a shunt mode; that is, directly across the a-c terminals (Fig. 2). This shunt mode allows very fast rise time for the pulse, typically 50 to 100 nsec in the absence of de-liberate sloping network. Furthermore, the source impedance of the surge can be readily adjusted as desired by controlling the parameters (cable characteristic impedance, or surge impedance of a capacitor bank).

In fact, the very flexibility of the circuit becomes a handicap in this case (too complicated for routine testing to a specific wave shape), and together with the relatively high cost and inability (as designed) to produce repetitive pulses, this makes this approach less attractive than the two others. On the other hand, when experimentation is the object, the flexibility of this circuit is a great asset.

III. THYRISTOR SWITCH AND STEP-UP PULSE TRANSFORMER

This circuit was designed with the specific objective of producing spikes on the a-c line, with the further aim of avoiding a high-voltage switch and the need for a filter. The surge is to be injected in series with the a-c line by a coupling transformer acting as a step-up pulse transformer. Figure 3 shows the schematic diagram of the circuit. Energy is stored in capacitor C, at about 500 volts. The thyristor discharges the capacitor through the primary of T_1 and the pulse is coupled across inductance L by the coupling capacitor C_2 . C_4 and C_3 serve, respectively, to bypass the a-c line and to control the ringing frequency. 60 Hz power is supplied through the isolating transformer T_2 .

The difficulty in this circuit, when fast rise times are desired, is to control the inductance of the T_1 primary loop, which must be in the order of 0.2 μ H or less for the rise time desired in this case. While the components for this circuit are of special design, a supplier was identified who could produce them for interested users. However, the relative complication of the circuit, the cost of the high current SCR required, made this approach less attractive than the third circuit, which will now be described in detail.

IV. RELAY-TYPE SWITCH WITH RESONANT CIRCUIT

The basic schematic diagram of the tester is shown in Fig. 4, and the relay control circuit is given in Fig. 5. Photographs of the waveforms are shown in Figs. 6 through 10.

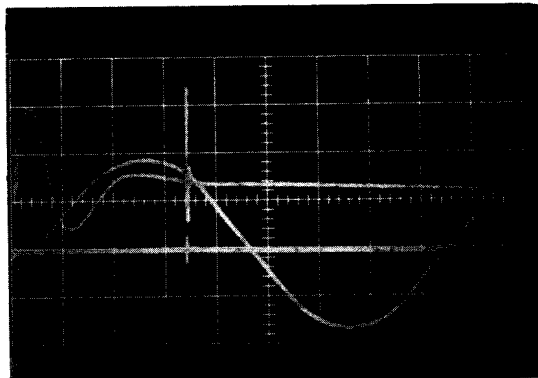
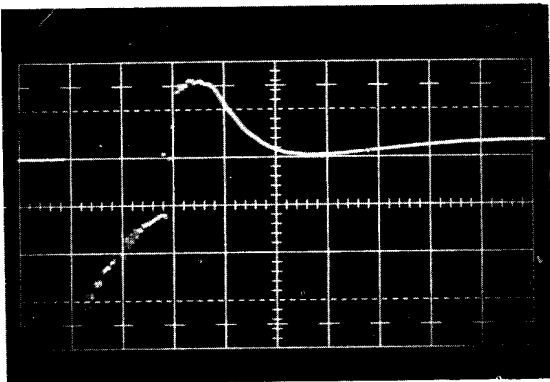
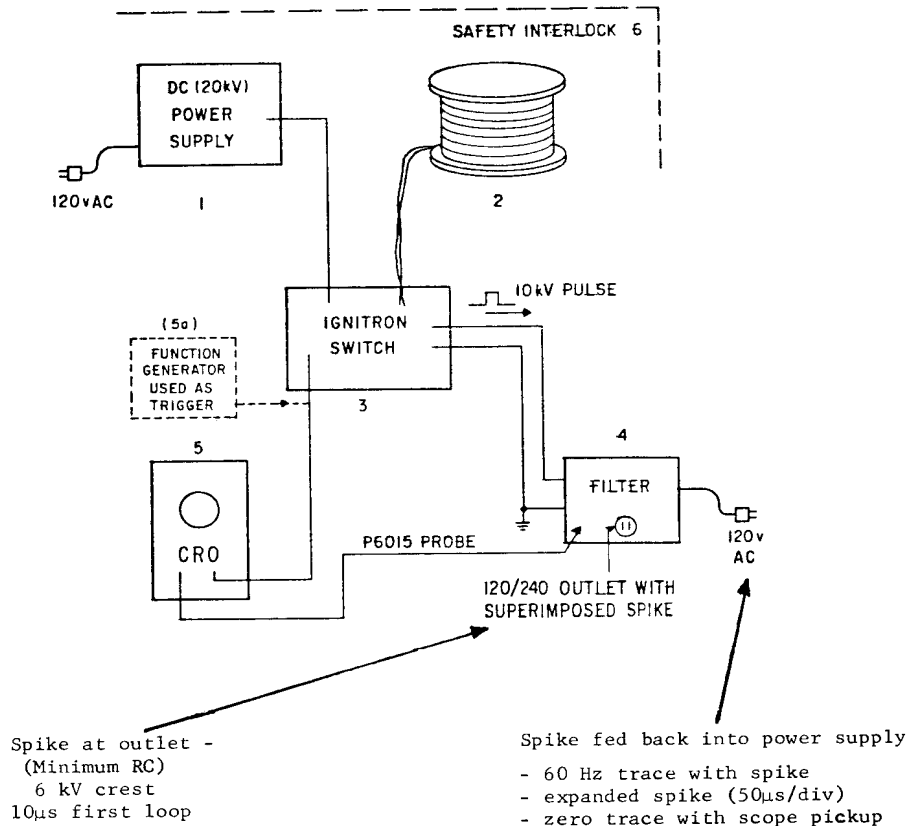

Fig. 2 Surges developed by the general-purpose circuit can be coupled into an a-c power supply.

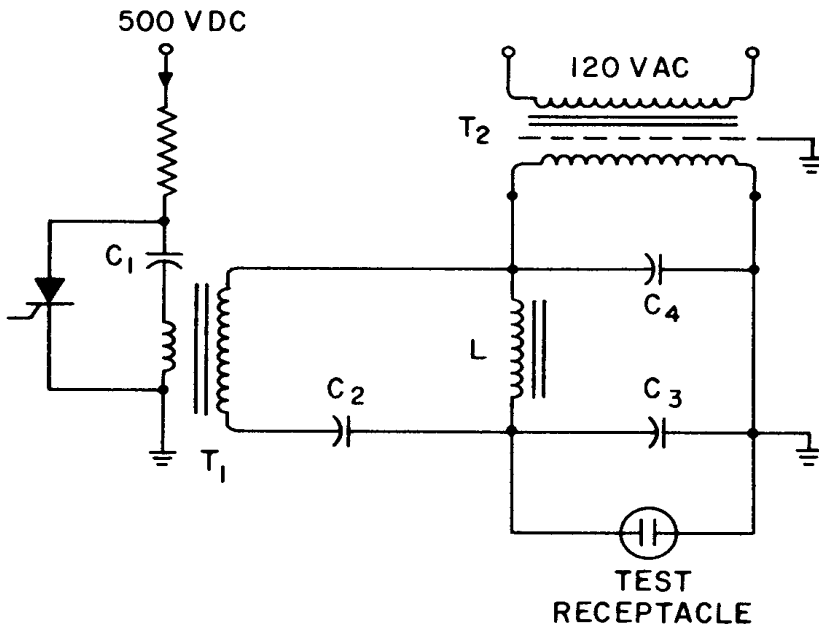
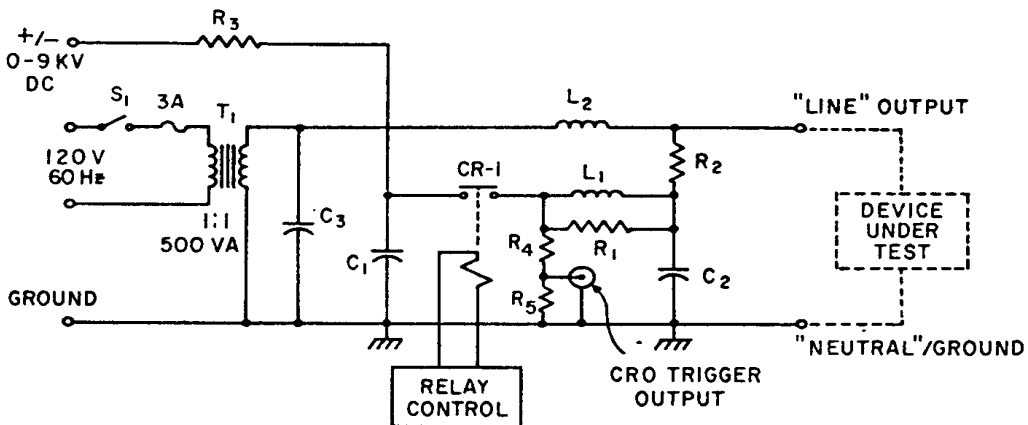
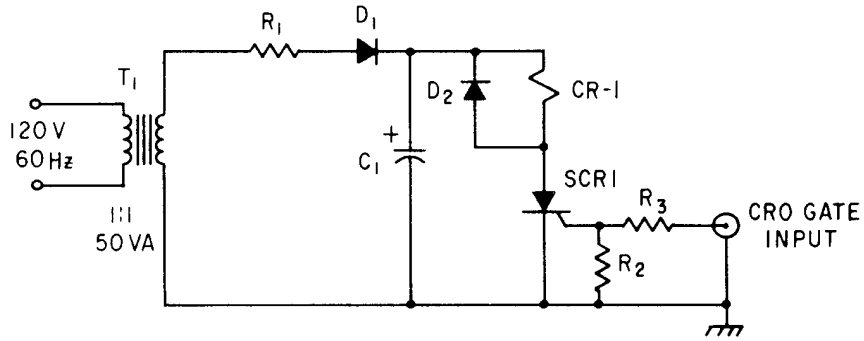

Fig. 3 Schematic circuit of test circuit with series injection by pulse transformer.



- * C_1 - .025 μ F, 10kV, (Gudeman, 2 x .01 + .005)
 - C_2 - .01 μ F, 10kV, (Plastic Capacitors, Inc.)
 - C_3 - 4 μ F, 400V
 - L_1 - 15 μ H (32 turns, #23 wire, 0.7" dia. Air Core)
 - L_2 - 70 μ H (28 turns, #23 wire, 2.6" dia. Air Core)
 - R_1 - 22 Ω , 1W, Comp.
 - R_2 - 12 Ω , 1W, Comp.
 - R_3 - 1.3M Ω (12 x 110K Ω , 1/2W)
 - R_4 - 47K Ω (10 x 4.7K Ω , 1/2W)
 - R_5 - 200 Ω , 1/2W
 - CR-1 - Relay, 2 N.O. poles in series
GE CR2790 E 100 A2
- * Gudeman GC 245S103M37 - .01 μ F
 Gudeman GC 245S502M37 - .005 μ F
 Plastic Cap.Inc. OF100-103F - .01 μ F

Fig. 4 Basic impulse generator circuit.



- | | |
|--------------------------|------------------------------------|
| $R1$ - $10k\Omega$, 1W | $D1, D2$ - IN5060 |
| $R2$ - $1k\Omega$, 1/2W | $SCR1$ - GE C122B |
| $R3$ - $1k\Omega$, 1/2W | $CR-1$ - Relay GE CR 2790 E 100 A2 |
| $C1$ - $32\mu F$, 250V | $T1$ - Triad N4S X |

Fig. 5 Relay control circuit for impulse generator.

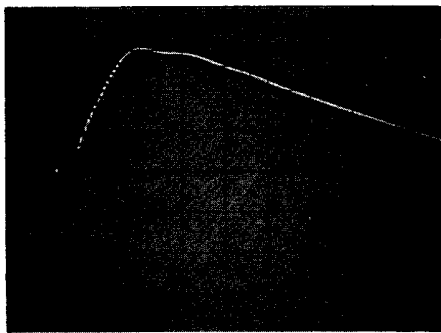

Vert: 2 kV/div Hor: 0.2 μs /div

Fig. 6 Impulse rise - no load.

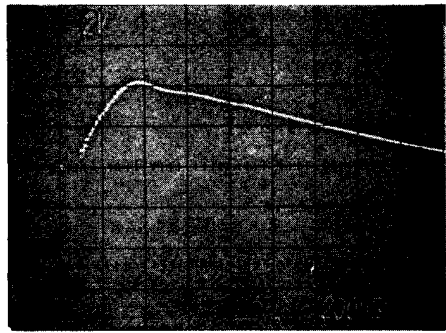

Vert: 2 kV/div Hor: 0.2 μs /div

Fig. 7 Impulse rise - 50 ohm load.

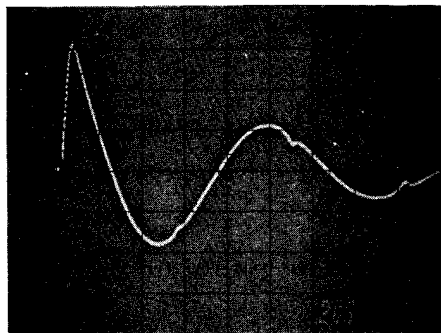

Vert: 2 kV/div Hor: 2 μs /div

Fig. 8 Ringing wave - no load.

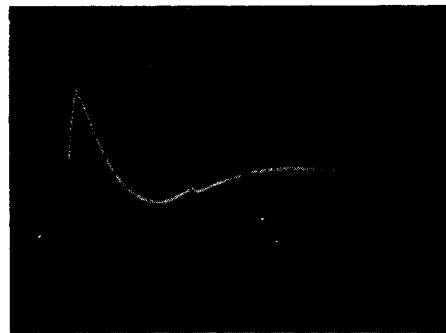

Vert: 2 kV/div Hor: 2 μs /div

Fig. 9 Ringing wave - 50 ohm load.

In principle, a d-c voltage is stored on capacitor C1. At about the 70 degree point on the 60 Hz supply wave, a pair of relay contacts are closed to connect C1 to the Line Output terminal by way of a wave-shaping network L1, R1, C2, R2, and L2. A large capacitor, C3, prevents transmission of the wave back into the power system. Figure 10 shows the pulse superimposed on the 60 Hz, 120 volt line (contact bounce produced two subordinate trailing pulses).

The 500 kHz rise characteristic is obtained by the series resonance of L1 and the capacitance of C1 and C2 in series. Component values are selected to make $\sqrt{L/C}$ approximately 50 ohms, and R1 was selected to provide heavy damping for a smooth transition to the following wave. Figure 6 shows the rise time, open-circuit, and Fig. 7 with 50 ohm load.

The 100 kHz damped ring results from the parallel resonance of L2 with the parallel capacitance of C1 plus C2. Again, $\sqrt{L/C}$ is about 50 ohms. The series damping resistor R2 was selected to produce the decay to 60% amplitude between successive peaks. Figure 8 shows the ringing wave on open circuit, and Fig. 9 shows the same wave when loaded by 50 ohms. A comparison of first-peak amplitudes shows that the source impedance is approximately the desired 50 ohms. Approximately 8 kV d-c charge on C1 is required to produce an open-circuit peak of 6 kV on the output terminal because of the charge transferred to C2.

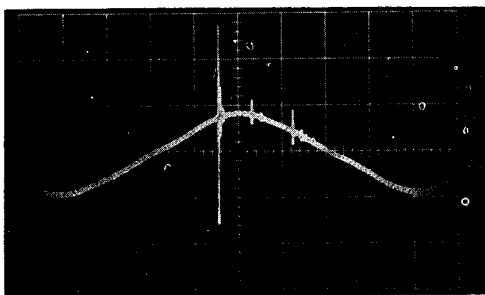

Vert: 200V/div Hor: 2ms/div

Fig. 10 Impulse superimposed on 120 volt line voltage - output of impulse tester.

At low voltages, the relay contacts behave normally, but at high voltages they can no longer be considered as contacts but rather as a moving spark gap. In Figs. 8 and 9 disturbances in the sinusoidal shape occur as current in the plasma reverses in each half-cycle. The introduction of heavy metal ions into the plasma, such as by use of a mercury relay, can reduce the extent of such waveform distortions; however, it is considered that these distortions do not materially tests.

Laboratory tests with this circuit used a storage CRO with delayed sweep and single sweep capabilities. The main sweep gate output was used to trigger the relay control circuit, and the main sweep was triggered from the 60 Hz line such as to produce the high-voltage surge at the desired point of line voltage. Main sweep duration was about 20 msec. The delayed sweep was first delayed 1 msec, then triggered by the output from divider R4, R5 at the start of the high-voltage rise time. Since the charging time constant on C1 is 0.033 second, the test can be repeated within 0.5 second.

It should be emphasized that this is an experimental design to illustrate a concept, not a product design. There are no operator-safety provisions shown, and only "qualified persons" must be allowed to operate the apparatus. The component values are approximations taken for ready availability and ease of construction. The performance does show, however, that the proposed test waveform can be produced by a relatively simple, inexpensive method.

ACKNOWLEDGMENTS

The general-purpose ignition switch and its control circuits were developed by R.N. Bushman as part of the laboratory equipment used in transients investigations at Corporate R&D.

The SCR/pulse transformer circuit and magnetic components was designed by H.W. Lord, especially for the purpose of producing the spikes on the a-c line voltage.

REFERENCES

1. F. D. Martzloff and G. J. Hahn, "Surge Voltages in Residential Power Circuits," IEEE Trans. Power Apparatus and Systems, PAS-89, No. 6 1049-1056 (July-Aug. 1970).
2. J. E. Lenz, "Basic Impulse Levels in Mercury Lamp Ballasts for Outdoor Application," Illum. Eng. 133-140 (Feb. 1964).
3. "IEEE Guide for Surge Withstand Capability (SWC) Tests," American National Standard, published by the Institute of Electrical and Electronics Engrs., Inc., Nos. IEEE Std. 472-1974 and ANSI C37-90a-1974.
4. "Ignitron Switch for Surge Generator," General Electric Publication GEI-45105, Corporate R&D Schenectady, N. Y.