



User's Manual

Precise[®] HEPA-Filtered Glove Boxes

Models	Voltage, Frequency
5220200	115V, 60 Hz
5220220	230V, 50 Hz
5220221	230V, 60 Hz
5220230	100V, 50 Hz
5220231	100V, 60 Hz

To receive important product updates,
complete your product registration card
online at **register.labconco.com**



*Protecting your
laboratory environment*

LABCONCO[®]

Labconco Corporation
8811 Prospect Avenue
Kansas City, MO 64132-2696
800-821-5525, 816-333-8811
FAX 816-363-0130
E-MAIL labconco@labconco.com
HOME PAGE www.labconco.com

Please read the User's Manual before operating the equipment.

The information contained in this manual and the accompanying products are copyrighted and all rights reserved by Labconco Corporation. Labconco Corporation reserves the right to make periodic design changes without obligation to notify any person or entity of such change.

Warranty

Labconco provides a warranty on all parts and factory workmanship. The warranty includes areas of defective material and workmanship, provided such defect results from normal and proper use of the equipment.

The warranty for all Labconco products will expire one year from date of installation or two years from date of shipment from Labconco, whichever is sooner, except the following;

- Purifier® Delta® Series Biological Safety Cabinets and PuriCare® Lab Animal Research Stations carry a three-year warranty from date of installation or four years from date of shipment from Labconco, whichever is sooner.
- SteamScrubber® & FlaskScrubber® Glassware Washers carry a two-year warranty from date of installation or three years from date of shipment from Labconco, whichever is sooner.
- Blood Drawing Chairs carry a ten year warranty.
- Carts carry a lifetime warranty.
- Glassware is not warranted from breakage when dropped or mishandled.

This limited warranty covers parts and labor, but not transportation and insurance charges. In the event of a warranty claim, contact Labconco Corporation or the dealer who sold you the product. If the cause is determined to be a manufacturing fault, the dealer or Labconco Corporation will repair or replace all defective parts to restore the unit to operation. Under no circumstances shall Labconco Corporation be liable for indirect, consequential, or special damages of any kind. This statement may be altered by a specific published amendment. No individual has authorization to alter the provisions of this warranty policy or its amendments. Lamps and filters are not covered by this warranty. Damage due to corrosion or accidental breakage is not covered.

Returned or Damaged Goods

Do not return goods without the prior authorization from Labconco. Unauthorized returns will not be accepted. If your shipment was damaged in transit, you must file a claim directly with the freight carrier. Labconco Corporation and its dealers are not responsible for shipping damages.

The United States Interstate Commerce Commission rules require that claims be filed with the delivery carrier within fifteen (15) days of delivery.

Limitation of Liability

The disposal and/or emission of substances used in connection with this equipment may be governed by various federal, state, or local regulations. All users of this equipment are required to become familiar with any regulations that apply in the user's area concerning the dumping of waste materials in or upon water, land, or air and to comply with such regulations. Labconco Corporation is held harmless with respect to user's compliance with such regulations.

Contacting Labconco Corporation

If you have questions that are not addressed in this manual, or if you need technical assistance, contact Labconco's Customer Service Department or Labconco's Product Service Department at 1-800-821-5525 or 1-816-333-8811, between the hours of 7:00 a.m. and 6:00 p.m., Central Standard Time.

TABLE OF CONTENTS

CHAPTER 1: INTRODUCTION	1
CHAPTER 2: PREREQUISITES	2
Support, Vibration & Preventive Requirements	3
Location Requirements	3
Exhaust and Blower Requirements	3
ISO Class 3 Definition	5
Electrical Requirements	7
Space Requirements	7
CHAPTER 3: GETTING STARTED	8
Unpacking the Glove Box	9
Installing the Glove Box on a Supporting Structure & Work Surface	10
Connecting to the Exhaust System (If Applicable)	10
Installation of Gloves to the Glove Ports	12
Connecting the Electrical Supply to the Glove Box	13
Setting Exhaust Volume with Speed Control Adjustment	13
Validating the Glove Box	14
Summary of Performance Testing Results	14
CHAPTER 4: PERFORMANCE FEATURES AND SAFETY PRECAUTIONS	16
Performance Features	16
Safety Precautions	19
CHAPTER 5: USING YOUR GLOVE BOX	21
Routine Daily Work Procedures	21
HEPA Filter Applications, Suitability & Guidelines	23
Definition of Terms	24
Appropriate Chemicals for Carbon Filters	24
Hazardous Misapplications for Carbon Filters with Volatile Chemicals	25
Chemical Carcinogen Use with Carbon Filters	25
Prohibited Acid Use	26

CHAPTER 6: MAINTAINING YOUR GLOVE BOX	27
Routine Maintenance Schedule	28
Decontamination	29
Determining When to Replace HEPA Filters	29
How to Install New HEPA Filters	29
HEPA Filter Leak Test	31
Initial Certification	33
Re-Certification	33
Fluorescent Light Replacement	33
Motorized Impeller Replacement	34
Speed Control Replacement	34
CHAPTER 7: ACCESSORIZING YOUR GLOVE BOX	35
CHAPTER 8: TROUBLESHOOTING	41
APPENDIX A: REPLACEMENT PARTS	42
APPENDIX B: DIMENSIONS	44
APPENDIX C: SPECIFICATIONS	45
APPENDIX D: IONIZER FAN PERFORMANCE CRITERIA	46
APPENDIX E: PRESSURE & FLOW RATE CONVERSIONS	48
APPENDIX F: REFERENCES	49
DECLARATION OF CONFORMITY	50

Chapter 1: Introduction

Congratulations on your purchase of a Labconco Precise® HEPA-Filtered Glove Box. Your glove box provides personnel protection through superior containment rated at Class 1 conditions for hazardous environments, per ISO 10648-2.

These glove boxes will effectively contain toxic or noxious particulates when properly installed and operated. In positive or negative pressure operation modes, the glove box can create an ISO standard Class 3 (ISO 14644-1) clean air environment. This glove box uses two HEPA filters, rated at least 99.99% efficient for 0.3-micron particles.

The Precise HEPA-Filtered Glove Boxes offer many unique features to enhance safety and performance. To take full advantage of them, please acquaint yourself with this manual and keep it handy for future reference. All glove box operators **must** read and understand how HEPA filtered glove boxes operate; please review *Chapter 4: Performance Features and Safety Precautions* before beginning to work with this glove box. Even if you are an experienced user, please review *Chapter 5: Using Your HEPA-Filtered Glove Box*, which describes the Precise features so that you can use the filtered glove box effectively and safely.

Chapter 2: Prerequisites

Before you install the glove box, you need to prepare your site for installation. You must be certain that the area is level and of solid construction. In addition, a dedicated source of electrical power should be located near the installation site to power the glove box. The glove box should be strategically placed in the lab to provide efficient workflow and prevent operator interference from normal traffic patterns.

Carefully read this chapter to learn the requirements for your installation site:

- The support, vibration and preventive requirements.
- The location requirements.
- The exhaust and blower requirements.
- The electrical power requirements.
- The space requirements.

Refer to *Appendix B: Precise HEPA-Filtered Glove Box Dimensions* for complete glove box dimensions.

Refer to *Appendix C: Precise HEPA-Filtered Glove Box Specifications* for complete electrical and environmental conditions, specifications and requirements.

Support, Vibration and Preventive Requirements

In the preparation of a glove box site, please consider the following:

- A bench or stand that is rigidly mounted to the floor or fixed to the wall, but not both, may be appropriate. 35" to 40" (889mm-1016mm) is typical for standing height. (Labconco stands offered in Chapter 7 vary from 33" to 40".)
- The corners of a building typically have less vibration than the center, which promotes analytical balance stability.
- The bench typically should not contain any vibration-producing equipment, such as shakers or pumps.
- A marble slab with dampening pads placed within the enclosure is an effective low cost means of controlling vibration (see *Chapter 7: Accessorizing Your Filtered Glove Box*).

Location Requirements

The Precise HEPA-Filtered Glove Boxes have been designed to rest on a typical 29"-30" (737mm-762mm) deep work surface. The height should be 35"-40" for standing position. Avoid placing the glove box in high traffic areas where walking might disrupt the operator or experimentation.

Exhaust and Blower Requirements

The Precise HEPA-Filtered Glove Box, as manufactured, uses an integral motorized impeller to pull room air through the inlet and exhaust HEPA filters and discharge the clean air back into the laboratory. This negative pressure operation mode pulls all internally-contaminated air through the exhaust HEPA filter. The HEPA-filtered exhaust air is then forced out the top of the glove box. An optional FilterMate™ Portable Exhauster with a carbon filter may be installed downstream of the exhaust to adsorb low levels of organic fumes, formaldehyde, or ammonia gases.

The HEPA-filtered exhaust air from the glove box can be exhausted to the outside with the installation of a thimble exhaust connection kit and remote blower listed in Chapter 7. As an option, if necessary, the built-in motorized impeller can be wall mounted if desired.

Labconco does not recommend a hard duct connection using the built-in motorized impeller as the source of airflow out of the facility. This creates a positive pressure in the exhaust duct.

Labconco does not recommend hard duct connections with remote blowers due to the air volume balance requirements with such systems. Hard duct connections should only be used when the glove box impeller is disconnected and only a single roof-mounted blower is used. Note that reliance on an external exhaust blower does not provide airflow control at the glove box.

If a positive internal pressure clean air ISO Class 3 condition (ISO 14644-1) is desired, the motorized impeller can be rotated to work in positive pressure mode (see Figure 3-3). See Chapter 7 for the Positive Pressure Conversion Kit. See the following Negative and Positive Pressure Particle Test data in the charts below. Both charts show the dilution rates of the glove boxes.

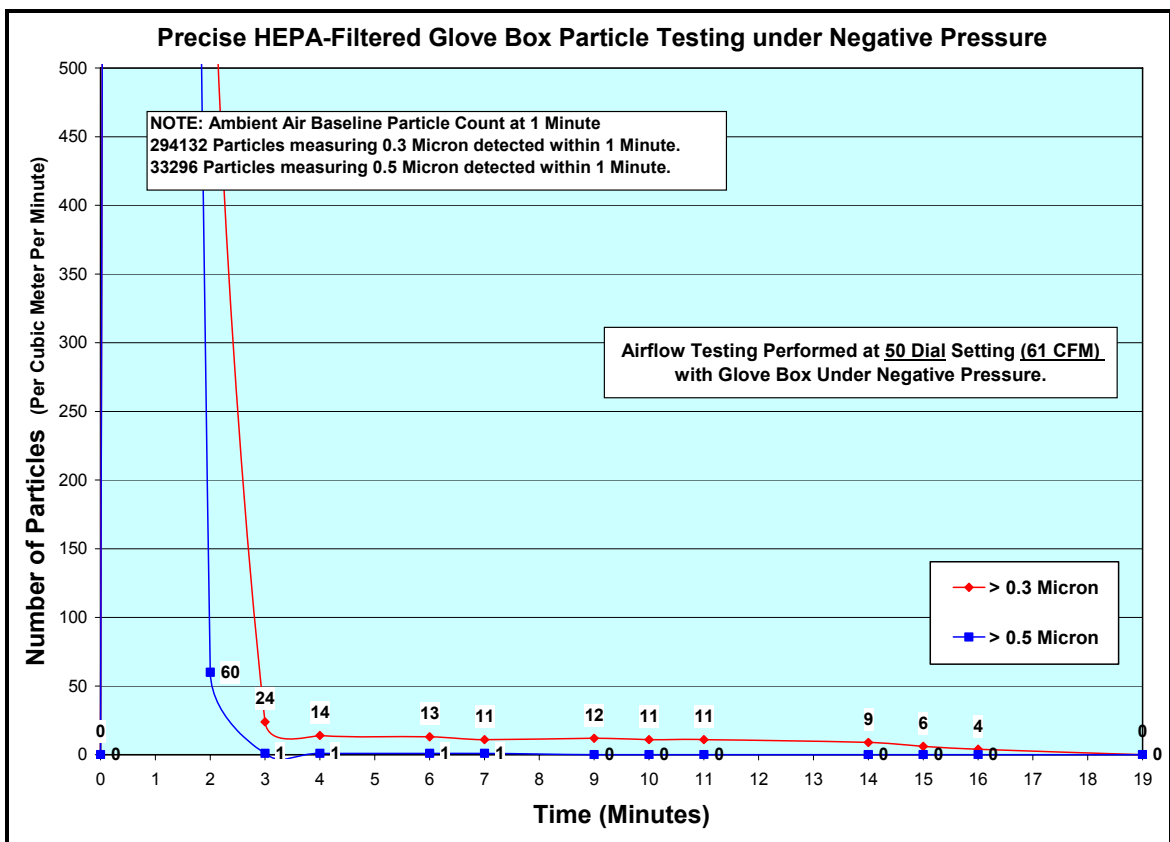

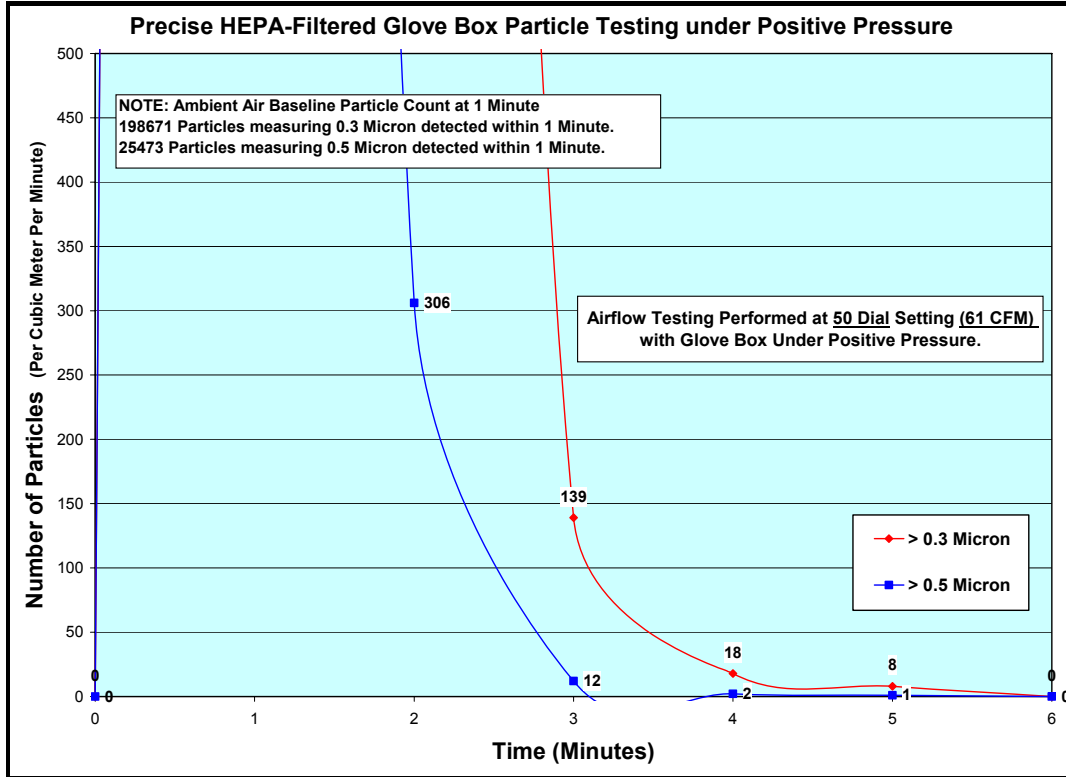

ISO Class 3 Definition

Airborne particulate cleanliness inside any clean air glove box or enclosure is designated by ISO Class 3, which is equivalent to 35 particles 0.5 μm or larger per cubic meter of air per minute as defined by ISO Standard 14644-1. ISO Class 3 cleanliness is illustrated in the table below and is equivalent to Class 1 air conditions as defined by Federal Standard 209E or 1 particle 0.5 μm or larger per cubic foot of air per minute.

Table 1-1 Selected airborne particulate cleanliness classes for cleanrooms and clean zones.

ISO classification number (N)	Maximum concentration limits (particles/m ³ of air/minute) for particles equal to and larger than the considered sizes shown below (concentration limits are calculated in accordance with 3.2 of Standard 14644-1)					
	0.1 μm	0.2 μm	0.3 μm	0.5 μm	1 μm	5 μm
ISO Class 1	10	2				
ISO Class 2	100	24	10	4		
ISO Class 3	1 000	237	102	35	8	
ISO Class 4	10 000	2 370	1 020	352	83	
ISO Class 5	100 000	23 700	10 200	3 520	832	29
ISO Class 6	1 000 000	237 000	102 000	35 200	8 320	293
ISO Class 7				352 000	83 200	2 930
ISO Class 8				3 520 000	832 000	29 300
ISO Class 9				35 200 000	8 320 000	293 000

Table 2-1 ISO Classification Number (N)

Chapter 2: Prerequisites

Additionally, the motorized impeller can also be used in a full recirculation mode providing the operator with some control of the atmosphere chemistry within the glove box. See Chapter 7 for the Recirculation Conversion Kit.

The airflow chart below represents typical operational data including air changes per minute, exhaust volume, noise levels, main chamber static pressures, and total system static pressures measured at the blower intake (suction side). Exhaust volumes are reduced by 17% for products operating on 100V, 60 Hz and reduced 34% for 100V, 50 Hz products.

Dial Setting	Air Changes per Minute (acm)	Exhaust Volume (CFM)	Noise Pressure dB (A)	Static Pressure Inside Glove Box (inches of water)	Total System Static Pressure (inches of water)
Min. Dial	1	13	44	.14	.34
20 Dial	1.5	20	48	.17	.51
40 Dial	3.3	43	48	.45	1.32
50 Dial	4.7	61	65	.68	1.81
60 Dial	6.2	80	68	.80	2.14
80 Dial	7.2	93	70	.89	2.38
Max. 100 Dial	7.7	100	71	.91	2.42
Dial OFF	0	0	37	0	0

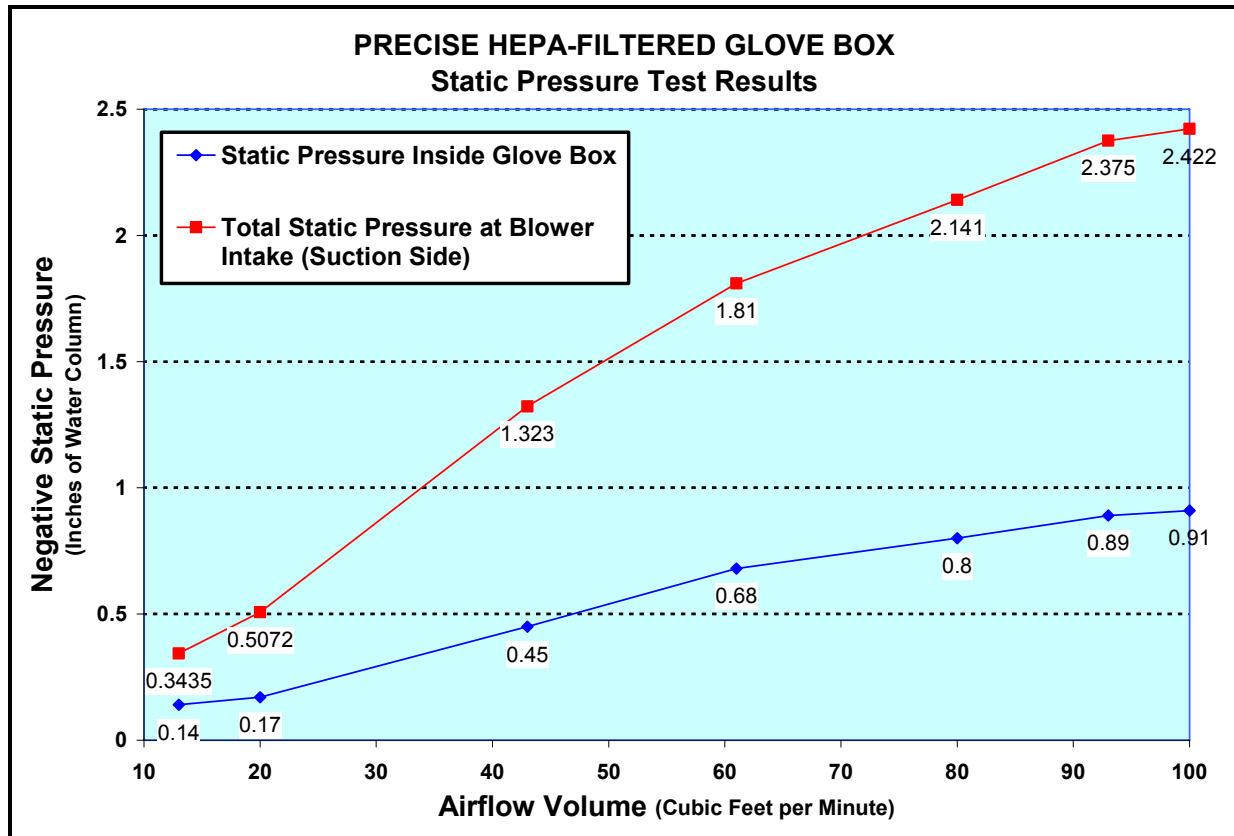

For thimble-ducted glove boxes, the proper remote blower selection can be determined from these exhaust requirements as the remote blower only needs to be sized for the static pressure loss of the ductwork system. The thimble ducted exhaust blower should be sized for 25% additional airflow. When exhausting a glove box to the outside, it should be connected to a dedicated remote blower.

Labconco offers accessory remote blowers listed in Chapter 7. Contact Labconco for blower sizing assistance.



When a glove box is connected to a remote blower exhaust system, an adjustable damper (or valve) should be installed in the duct to control the airflow volumes properly. See Chapter 7 for Exhaust Dampers.

Electrical Requirements

Electrical service should be nearby for connecting the glove box, and accessory equipment. The glove box is rated 115V, 8A or 230V, 4A or 100V, 8A. A convenience duplex outlet is located inside the glove box and is rated for 115V, 5A or 230V, 2A or 100V, 5A. Additional power strip accessories are available for connection to the duplex outlet and are listed in Chapter 7.

Space Requirements

The dimensions are shown in *Appendix B: Dimensions*.

Chapter 3: Getting Started

Once the site for your Precise Glove Box is properly prepared, you are ready to unpack, inspect, install, and validate your system. Read this chapter to learn how to:

- Unpack and move the glove box.
- Set up the glove box with the proper supporting structure and work surface.
- Connect to an exhaust system if applicable.
- Install the gloves.
- Connect the electrical supply.
- Set the exhaust volume with the speed control adjustment.
- Arrange validation for the glove box.



Each Precise Glove Box weighs 205 lbs. (90 kg). The shipping container allows for lifting with a mechanical lift truck or floor jack. If you must lift the enclosure manually, follow safe-lifting guidelines. Do not lift by the upper sheet metal façade and front panel as damage can occur to the plastic glove box liner (see Figure 3-1).

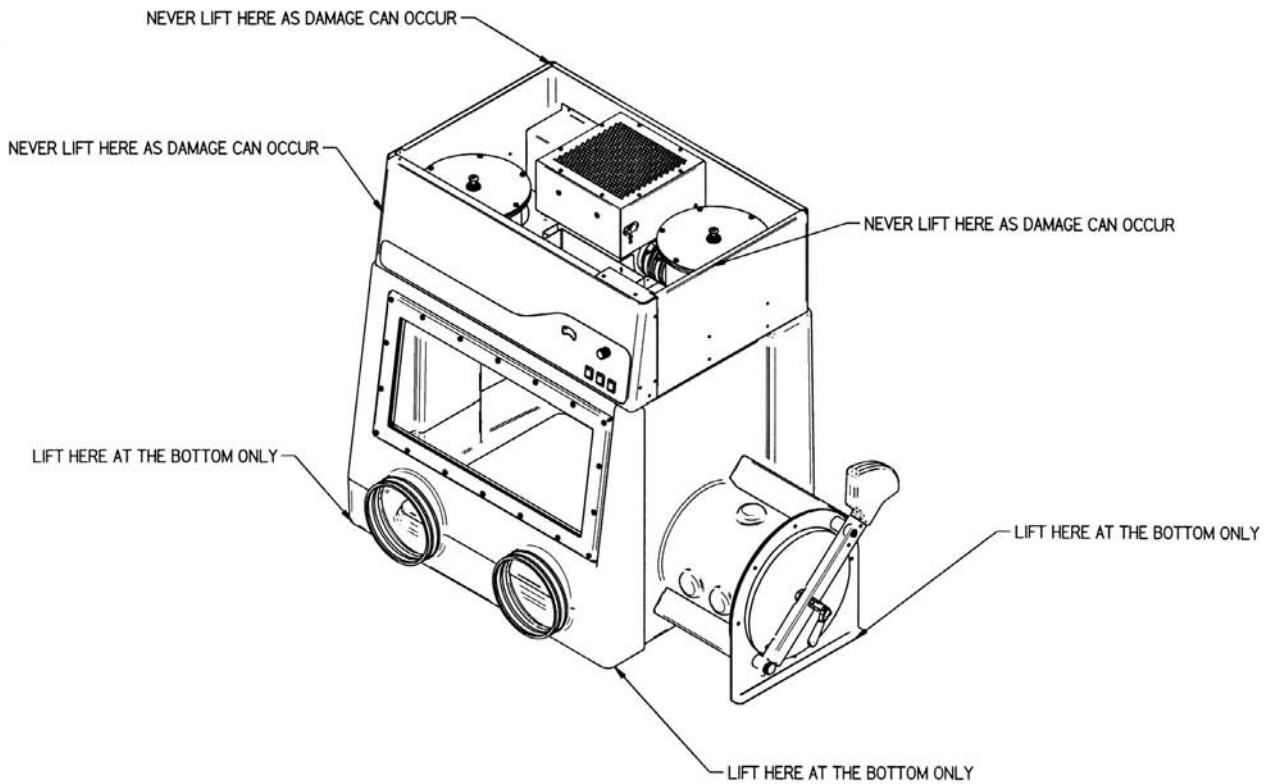

Figure 3-1
Lifting Instructions

Unpacking the Glove Box

We recommend that you do not remove the glove box from its shipping container until it is ready to be placed into its final location. Move the unit by placing a flat, low dolly under the shipping skid, or by using a floor jack.

Carefully remove the carton shrink-wrap on the glove box and inspect it for damage that may have occurred in transit. **If damaged, notify the delivery carrier immediately and retain the entire shipment intact for inspection by the carrier.**



THE UNITED STATES INTERSTATE COMMERCE COMMISSION RULES REQUIRE THAT CLAIMS BE FILED WITH THE DELIVERY CARRIER WITHIN FIFTEEN (15) DAYS OF DELIVERY.



DO NOT RETURN GOODS WITHOUT THE PRIOR AUTHORIZATION OF LABCONCO. UNAUTHORIZED RETURNS WILL NOT BE ACCEPTED.



IF ENCLOSURE WAS DAMAGED IN TRANSIT, YOU MUST FILE A CLAIM DIRECTLY WITH THE FREIGHT CARRIER. LABCONCO CORPORATION AND ITS DEALERS ARE NOT RESPONSIBLE FOR SHIPPING DAMAGES.

Do not discard the packing material until you have checked all of the components and tested the glove box.

Installing the Glove Box on a Supporting Structure and Work Surface

Exercise caution when lifting or moving the glove box.

When installing the glove box onto a work surface or benchtop, ensure that the structure can safely support the combined weight of the glove box and any related equipment. The work surface should be as wide as the glove box to properly support it. The front of the glove box should be aligned with the front of the work surface for optimal comfort. A height of 35"-40" (889mm-1016mm) is appropriate for standing operation. Adjustable Height Base Stands listed in Chapter 7 may be adjusted from 33"-40" (838mm-1016mm).

Connecting to the Exhaust System (If Applicable)



WARNING: The weight of any exhaust ductwork system must be supported independently of the glove box superstructure or damage may occur.



The exhaust system should be installed by a qualified HVAC contractor.

The Precise HEPA-Filtered Glove Box has been manufactured to exhaust into the laboratory in its standard configuration. To remove chemical fumes and odors not trapped by the HEPA filter, the glove box can be exhausted to the outside, or connected to an accessory FilterMate Portable Exhauster with carbon filters (see Figure 3-2). See Chapter 7 for accessories including: Thimble Exhaust Connection, FilterMate Portable Exhauster, Positive Pressure Conversion Kit, Recirculation Kit, Hard Duct Connection.

Consult Labconco Customer Service if you require help sizing a remote blower for the exhaust volume and the duct work system (static pressure loss listed in Chapter 2).



To ensure compatibility, the selected exhaust duct material should match the enclosure, procedures and chemical applications.

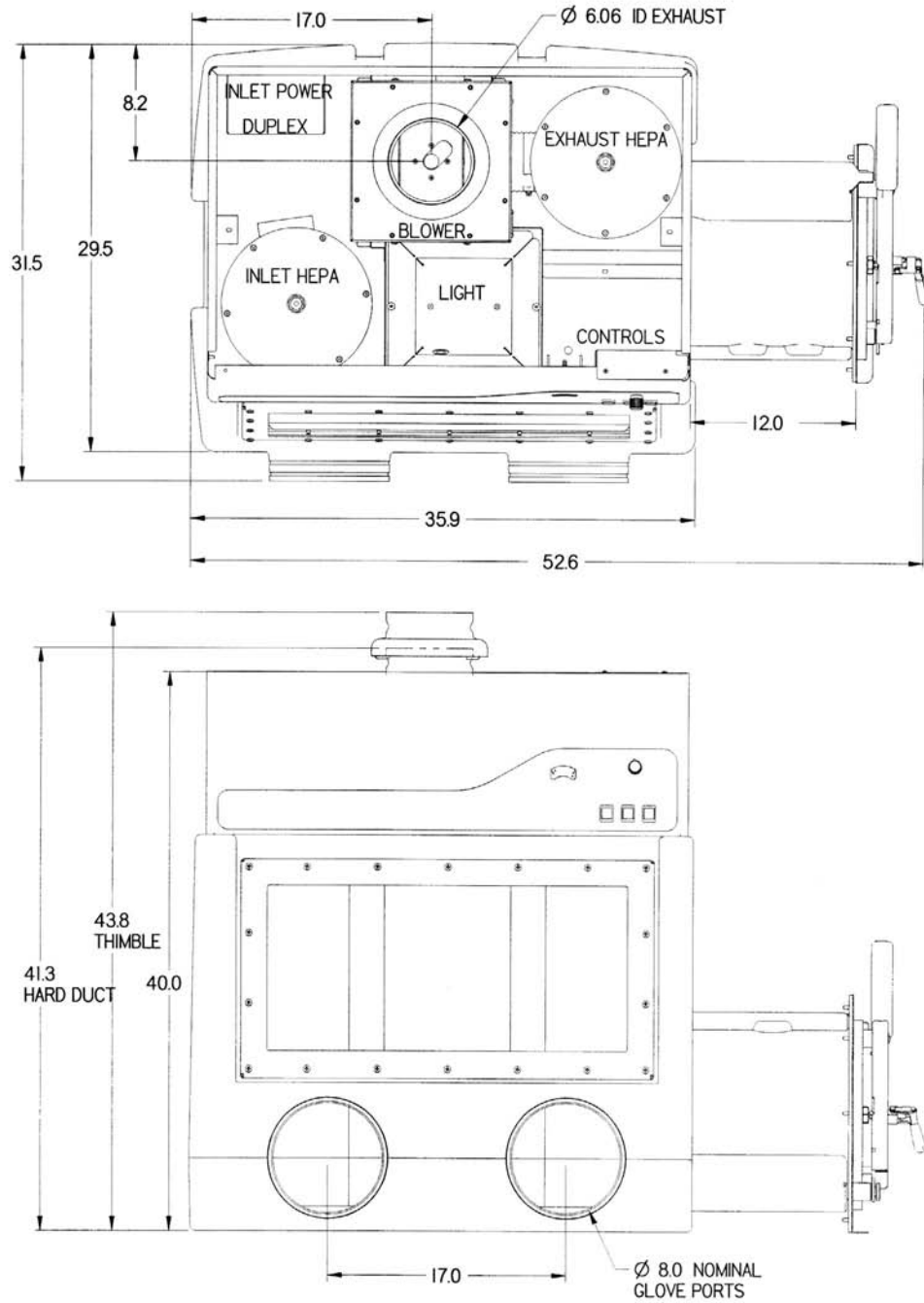

Figure 3-2
Exhaust Connection to Outside
 (All dimensions in inches)

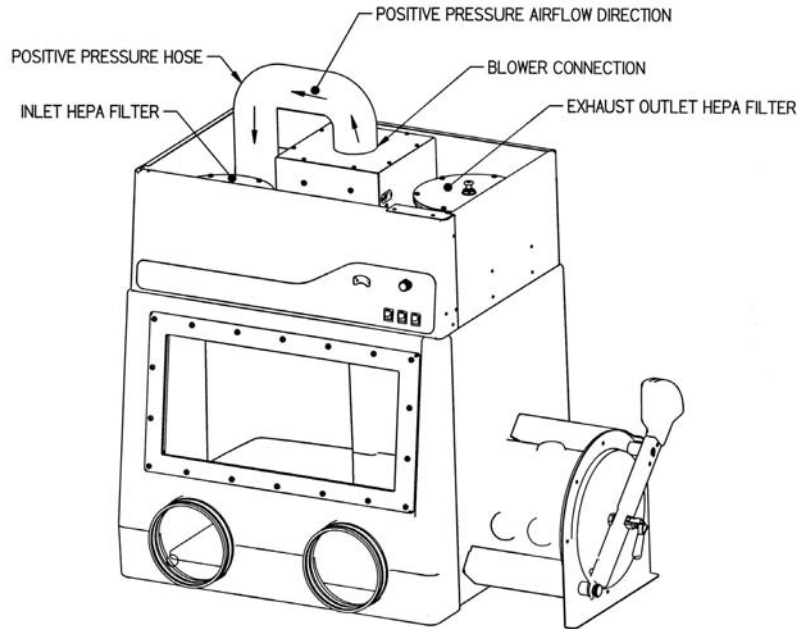

Figure 3-3
Positive Pressure Glove Box Configuration

Installation of Gloves to the Glove Ports

With thumbs up and right/left orientation, secure the gloves in place on the glove ports by stretching the beaded cuff into the groove nearest the window. Install the separate 8" diameter O-ring over the gloves and into the outer groove of the glove port surface. Stainless steel band clamps are provided for securing the separate O-ring into the glove port groove. Replacement gloves and parts are listed in Appendix A with a description in Chapter 7.

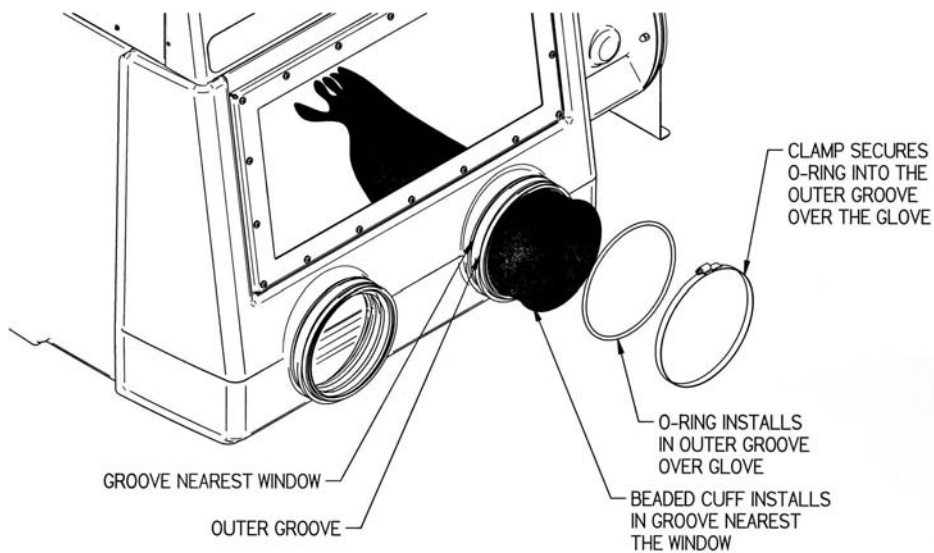

Figure 3-4
Glove Installation

Connecting the Electrical Supply to the Glove Box

115V, 60 Hz; 100V, 50 Hz; or 100V, 60 Hz Models

Connect the power cord supplied to the IEC electrical supply plug on the back of the glove box. 115V or 100V models are rated at 8 amps total.

The maximum circuit load for the interior electrical duplex is 5 amps.

230V, 50 Hz or 230V, 60 Hz Models

The same procedure applies for the 230V model except it is shipped without a plug. Install the appropriate plug per local requirements. The 230V, 50 Hz or 230V, 60 Hz models are both rated at 4 amps total. **The interior electrical duplex is rated at 2 amps.**

Setting the Exhaust Volume with the Speed Control Adjustment

For Precise HEPA-Filtered Glove Boxes, adjustment of the speed control provides control of exhaust air volume and is located on the front panel. The exhaust air volume should be adjusted at the low setting for weighing operations. **(Consult your Safety Officer for airflow recommendations for your application).** Working at the lowest exhaust volume appropriate for the application will give the quietest operation. To increase the rate of air volume changes after working in the glove box and to ensure proper cleaning, the speed control should be set at a higher (50 to 100) dial setting for 5 to 10 minutes as recommended by the operator's predetermined protocol and the chart below. The exhaust volume is increased by turning the speed control counterclockwise.

Dial Setting for Cleaning Internal Air Volume	Approximate Air Volume Changes per Minute	Estimated Total Exhaust Volume (CFM)	Minimum Recommended Times to Clean Internal Air Volume (minutes)
50	4.7	61	10
100	7.7	100	5

Validating the Glove Box

The Precise HEPA-Filtered Glove Box has been leak tested at the factory for HEPA filter and main chamber pressure integrity. The HEPA filters should be leak checked upon start-up and annually thereafter per the procedure in Chapter 6. **Upon start up, the main chamber pressure should be greater than 0.7" w.g. at full blower speed to validate proper blower operation; if not, contact Labconco for service.**



NOTE: Main chamber pressure and smoke removal tests should be performed frequently, per your established quality system, to ensure safe performance.

Summary of Performance Testing Results

Labconco's test results show that the Precise HEPA-Filtered Glove Box meets all the performance criteria when operated at the following estimated airflow volumes: 61 CFM or less for weighing with an analytical balance or handling powders and 61 CFM or above for safe air clean up. The Precise HEPA-Filtered Glove Box has been tested to the point of insufficient performance. In each case, the lack of performance occurred at airflow volumes below Labconco's minimum recommended airflow volume for the specific operation. Contact Labconco or visit www.labconco.com for complete performance test data. The following provides a brief summary of the findings:

- Smoke removal was tested at minimum 13-CFM to maximum 100-CFM airflow volumes. The time required to completely purge the main chamber of smoke varied from approximately 75 seconds at 100-CFM, to 420 seconds at 13-CFM.
- During tracer gas containment tests with the glove box vented to the outside, no gas was detected within the operator's breathing zone. Perimeter scans were also conducted during tracer gas testing of the Precise HEPA-Filtered Glove Box. Under normal laboratory conditions the tracer gas levels detected during perimeter scan testing were below ASHRAE 110 permissible limits (0.10 PPM average or less) and achieved Labconco permissible limits (0.05 PPM average or less).
- Sound levels "Noise Pressure" varied from 44 dB(A) at 13-CFM to 71 dB(A) at 100 CFM. If vented to the outside, the sound level will be greatly reduced.
- Airborne particulate cleanliness (measured under positive and negative pressures) within the main chamber of the glove box exceeded ISO Class 5 conditions (equivalent to Class 100) and achieved ISO Class 3 conditions (equivalent to Class 1) at both minimum and maximum operational airflow volumes.
- Glove box fluorescent lamp light levels "illumination" (measured across the work surface) averaged 29.9 foot candles with room lights turned off

and 33.7 foot candles with the test lab's overhead fluorescent lights turned on.

- Static pressure measured inside the glove box varied from negative 0.14 inch of water column at minimum 13-CFM to negative 0.91 inch of water at maximum 100-CFM. The total system static pressure measured between the exhaust filter and the blower varied from negative 0.34 inch of water column at 13-CFM to negative 2.4 inches of water at 100-CFM.
- The vibration level “displacement” measured on the work surface is negligible at minimum through maximum airflow volume settings. The measured level of displacement ranged from 0.59×10^{-5} inches to 1.45×10^{-5} inches.
- The static electricity measured on the work surface and interior surfaces of the glove box achieved a negligible level (below +/- 100V on any surface) with the glove box blower operating at a min 13-CFM to max 100-CFM at 22% relative humidity. Test conditions included the ionizer fan speed set to high output and the potentiometer within the ionizer was adjusted slightly between positive and negative output in order to maintain balanced ionization. The time required for sufficient electrostatic decay will vary depending upon user application, moisture levels within the supply air and the level of cleanliness within the glove box interior. Anti-Static Ionizer Fan is sold separately (see Chapter 7).
- The helium leaks ranged from 2×10^{-4} to 1×10^{-6} ml/sec with no individual leak greater than the specified 1×10^{-3} ml/sec.
- Balance stability testing results were excellent with no detectable instability of an analytical balance to five decimal places and a top loader balance to three decimal places. Test results were confirmed for various sample weights with the glove box running at various blower airflow settings.

Chapter 4: Performance Features and Safety Precautions

Performance Features

The Precise HEPA-Filtered Glove Box is designed to meet the needs of the laboratory scientist, and provide superior particulate containment. The HEPA-filtered glove boxes have been tested to effectively contain toxic and noxious materials when properly installed and operated. Labconco engineered the HEPA-Filtered glove boxes to minimize the effects of turbulence. The concentrations of particulate materials are predominantly removed from the main chamber by controlling the frequency of main chamber air volume changes. See Figure 4-1 to refer to a detailed description of the main performance features.

1. **Molded One-Piece Chemical-Resistant Glove Box Shell** made of medium density polyethylene, which provides superior chemical resistance. The molded liner is seamless and easy to clean with coved interior corners.
2. **Versatile Vibration Isolated Motorized Impeller** Isolation supports eliminate the transfer of vibration to the work surface which is extremely important in weighing operations with precision analytical and micro balances. The impeller wheel is also dynamically balanced capable of a minimum airflow of 13 CFM to a maximum of 100 CFM. Measured displacement for vibration is less than 1.5×10^{-5} inches. Additional unique features of the impeller include an optional Positive Pressure Kit, a Recirculation Kit, and a Blower Wall Mount Kit (see Chapter 7).
3. **HEPA Filter System** consists of the inlet and outlet HEPA filters rated 99.99% efficient on 0.3 micron particulates. Inlet and outlet HEPA filters are identical and include a test port for challenging the HEPA filter integrity. An optional filter bag may be ordered for bag-in/bag-out filter change procedures (see Chapter 7).

4. **Main Chamber Static Pressure Gauge** provides an indication of HEPA filter condition inside the glove box. Typically, HEPA filters should be replaced when the static pressure gauge reading has increased two-fold. The gauge can be changed to positive pressure for clean air glove box operations by reversing the hose on the gauge to the positive pressure connection. Positive Pressure Conversion Kit is sold separately (see Chapter 7).
5. **Glove Ports** are 8" nominal size and molded into the main glove box shell. The double grooves provide two points of restraint for safe changing of the gloves.
6. **Neoprene Gloves** are supplied with the glove box, .015" thick, 30" long, one pair, size 9 ³/₄. See Appendix A for replacement parts and Chapter 7 for a description.
7. **Removable Framed Glass Window** is 1/4" thick laminated safety glass and is reinforced with powder-coated steel frame. The removable glass window frame provides access to the interior for loading large apparatus. When removed, the window opening is 26.4" wide x 12.5" high (670mm wide x 317mm high). The framed glass window is sealed with a one-piece molded neoprene gasket. See Chapter 7 for optional Acrylic Viewing Window with Frame.
8. **Fluorescent Lamp** provides 30-40 foot candles of interior illumination on the work surface. The lamp may be replaced from outside the glove box. See Chapters 6 and 7 for replacement.
9. **Control Panel** consists of the main chamber static pressure gauge, switches for the light, blower, duplex outlet, and speed control. The speed control can vary the impeller speed from 13 to 100 CFM.
10. **Work Surface** is black chemically-resistant phenolic core and sealed to the glove box floor. The black surface aids proper cleaning and provides high visibility of powders. Phenolic core has superior chemical resistance and stain resistance.
11. **Interior Switched Duplex** is located on the glove box ceiling. The innermost outlet of the duplex labeled "AUX" is switch operated on the front control panel. An accessory Electrical Power Strip can be connected and ordered from Chapter 7. **The interior duplex is rated at 115V, 5A or 230V, 2A or 100V, 5A.**
12. **Transfer Chamber Doors** have a molded one-piece neoprene gasket with a quick operating latch for user comfort. The counterweighted doors swing up to save space. **IMPORTANT: Transfer chamber must have an optional High Vacuum Sleeve if the chamber is converted for vacuum operation. See Chapter 7.**

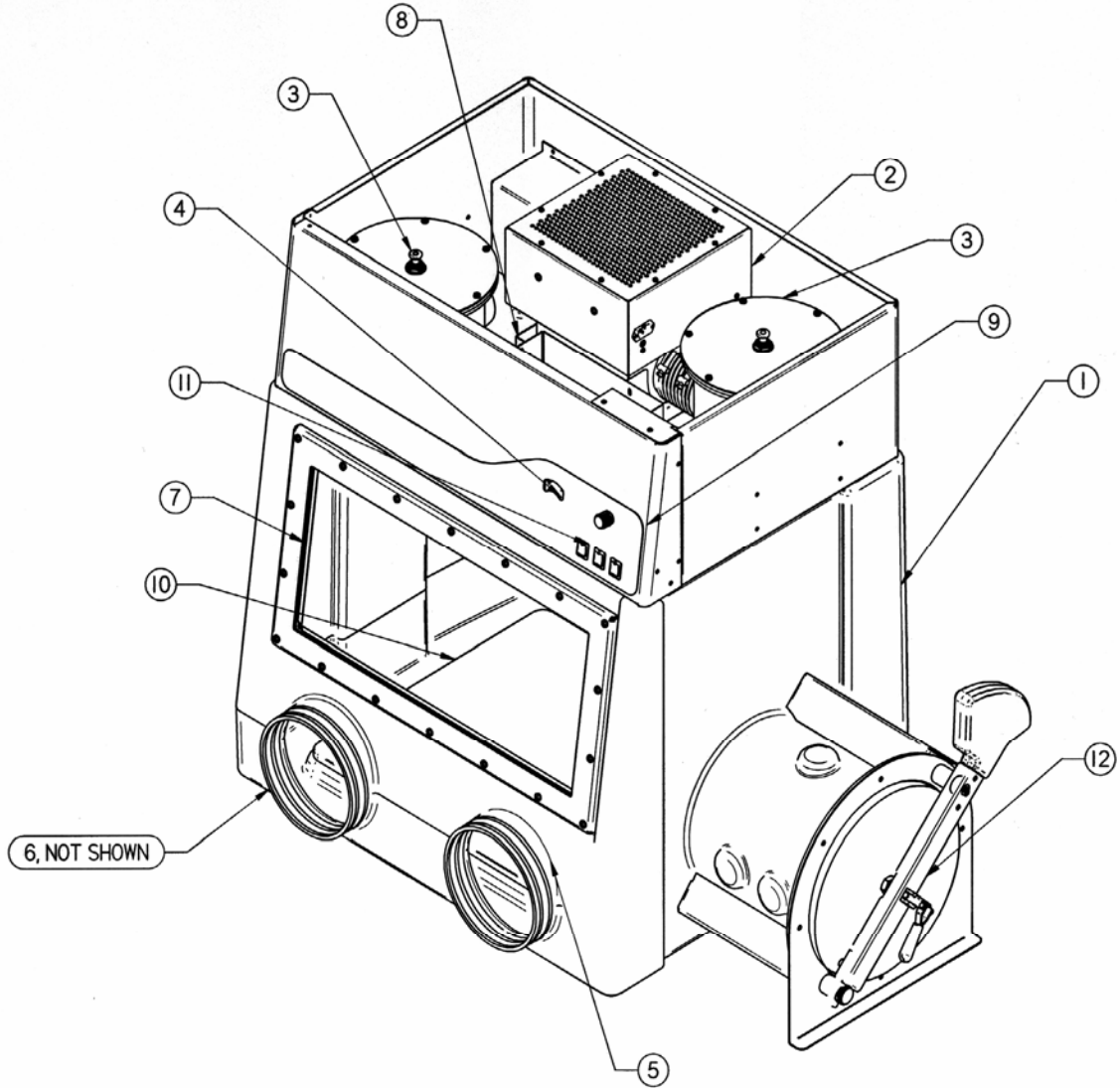

Figure 4-1

Safety Precautions

1. It is the responsibility of the user to determine the suitability of this product for the intended applications. Consult your Safety Officer.
2. Prior to using the glove box, check to make sure that the exhaust blower is operating and that air is entering the glove box by observing the static pressure gauge.
3. Use good housekeeping in the enclosure at all times. Clean up spills immediately. Periodically clean glove box interior.
4. This product is not designed or intended to be explosion proof. It is the responsibility of the user to determine and avoid lower explosive limits and flammability of any enclosed chemicals or gases. The user is also responsible for taking proper precautions to prevent equipment damage or injury due to explosion or combustion.
5. Avoid the use of flammable gases or solvents in the glove box. Care must be taken to ensure against the concentration of flammable or explosive gases or vapors. Use of an open flame or exposure to high heat should be avoided in the glove box as heat can damage the liner. Heat may harm the HEPA filter and damage the filter's adhesive.
6. Perchloric acid use in this enclosure is prohibited.
7. Radioisotope usage in the glove box should be cleared with your Safety Officer.
8. A qualified certification technician should test the integrity of the HEPA filters before the box is initially used.
9. The glove box should be recertified whenever it is relocated or serviced and at least annually thereafter.
10. The use of safety goggles, protective clothing, and any other personal protective equipment recommended by your safety officer should be employed.
11. The HEPA filter provides personnel and environmental protection from particulate matter. Should the blower be reversed to positive pressure inside, this glove box may be used for operations requiring product protection from environmental particulate contamination.
12. HEPA filters are only effective for entrapment of particulate matter. Manipulations that generate gases or vapors from toxic chemicals or radionuclides are not captured by the HEPA filters.

13. The surface of the HEPA filter is fragile and should not be touched. Care must be taken to avoid puncturing the HEPA filter during installation or normal operation. If you suspect that a HEPA filter has been damaged **DO NOT** use the glove box; contact a local certification agency or Safety Officer.
14. The HEPA filters in the glove box will gradually accumulate airborne particulate matter from the room and from work performed in the glove box. The rate of accumulation will depend upon the cleanliness of the room air, the amount of time the glove box is operating and the nature of work being done in the glove box. With normal usage, the HEPA filters will last two to five years before requiring replacement (see Chapter 6).
15. Ensure that the filtered glove box is connected to an electrical service in accordance with local and national electrical codes. Failure to do so may create a fire or electrical hazard. Do not remove or service any electrical components without first disconnecting the glove box from electrical service.
16. Used HEPA filters may be hazardous waste. The user is responsible for recording chemicals used and disposal of used filters.
17. Ensure only trained operators use the glove box. New users **must** review the User's Manual with emphasis on Routine Daily Work Procedures in Chapter 5 and become familiar with the safe operation of the glove box.
18. Only powders and particulates removed by HEPA filters are appropriate for use in this glove box. Vapors and other gases should be exhausted to the outside or adsorbed with the use of an accessory FilterMate Portable Exhauster equipped with carbonfilters. See Chapter 7.
19. Leave the impeller on for at least 5-10 minutes at 50%-100% speed after work in the glove box has been completed to purge the interior of containments.
20. If a chemical, powder or particulates are spilled on the work surface, **DO NOT** switch off the blower until all traces have been removed.
21. Tag glove box with appropriate warning if filters have been removed or the glove box requires servicing.
22. If the blower fails during use, processes should cease and the area should be vacated. Inform your Safety Officer immediately.
23. Consult your Safety Officer before removing any hoses to the static pressure gauge or exhaust hoses as they may be contaminated.

Chapter 5:

Using Your Glove Box

Now that the installation of your glove box is completed, you are ready to use your Precise HEPA-Filtered Glove Box.

Read this chapter to learn about:

- Routine Daily Work Procedures
- Appropriate HEPA Filter Applications, Suitability and Guidelines
- Carbon Filter Exhaust Applications
- Definition of Terms
- Appropriate Chemicals for Carbon Filters
- Hazardous Misapplications for Carbon Filters
- Chemical Carcinogen use with Carbon Filters
- Acid Use

Routine Daily Work Procedures

Planning

- Thoroughly understand procedures and equipment required before beginning work.

Start-up

- Consult your Safety Officer for personal protective equipment recommendations.
- Turn on exhaust system and light.
- Allow the enclosure to operate for 2-5 minutes at 50-100% blower speed.

Loading Materials and Equipment (see Figure 5-1)

- Load only the materials required for the procedure. Do not overload the glove box.
- Be aware that gloves will inflate when the glove box is operated under negative pressure. Ensure items in the glove box will not obstruct the movement of the gloves.
- After loading, wait 2-5 minutes at 50-100% blower speed to purge airborne contaminants from the work area before beginning procedures.

Work Techniques

- Segregate all clean and contaminated materials in the work area.

Final Purging (see Figure 5-1)

- All open trays, weigh vessels or containers **must** be sealed before being removed from the glove box.
- Objects in contact with contaminated material **must** be surface decontaminated before removal from the glove box.
- The interior surfaces should be cleaned per user's protocol.
- Upon completion of work, the glove box should be allowed to operate for 5 minutes undisturbed at 100% speed or 10 minutes at 50% speed to purge and dilute airborne contaminants from the work area.
- After purging the main chamber, the transfer chamber should also be purged for 5 minutes at 100% speed or 10 minutes at 50% speed with the inner door open, before removing sealed material.

Shutdown

- Turn off the exhaust system and light.
- Keep outer door closed when not in use.

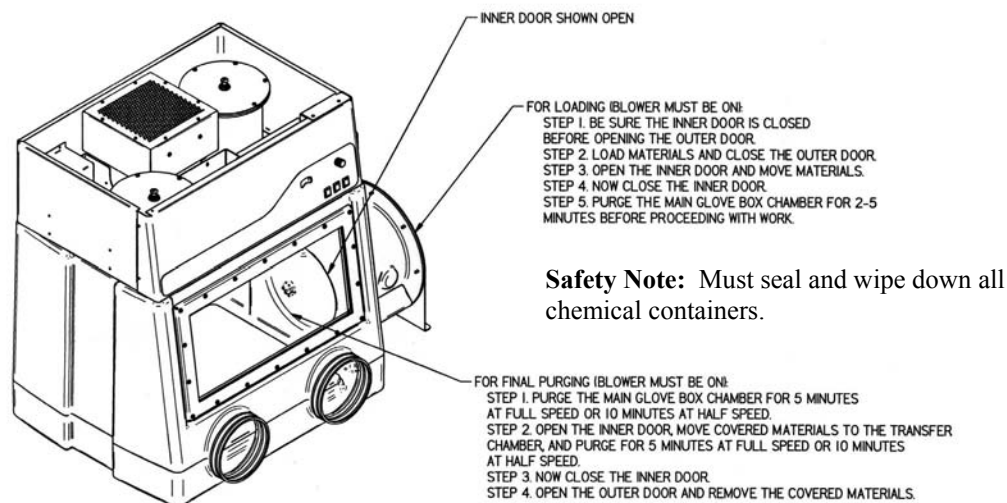

Figure 5-1
Loading and Final Purging Technique

HEPA Filter Applications, Suitability and Guidelines

- Microbiological materials and hazardous solids containment protecting only the operator and the surrounding environment.
- Weighing of powders.
- Containment of hazardous particulates using a HEPA filter.
- Powder or particulate procedures traditionally performed on an open bench.
- The HEPA filtered glove box provides personal and environmental protection from particulate matter, hazardous powders and microbiological materials.
- This glove box can be used for sample protection by reversing the blower airflow direction, causing the main chamber to be under positive pressure. Positive Pressure Conversion Kit is required (see Chapter 7).
- Manipulations that generate gases or vapors, i.e., toxic chemicals or radionuclides, require the use of a HEPA and carbon filter in combination. Otherwise the glove box should be ducted to the outside.
- Each filtered glove box is provided with two HEPA filters. Follow the HEPA Filter change procedure in Chapter 6 for disposal instructions. For microbiological materials, follow the Decontamination Procedure in Chapter 6 for disposal instructions.

Definition of Terms

NIOSH – National Institute for Occupational Safety and Health/Mine Safety and Health Administration. (U.S.A.)

TWA – Recommended Exposure Limits expressed as a Time Weighted Average. The exposure limit for that chemical for up to a 10-hour workday, 40 hours a week. Expressed in units of parts per million or milligrams per cubic meter.

Odor Threshold – The value in parts per million or milligrams per cubic meter for which one might expect to smell a chemical's presence in the air. This value is very subjective and detection will vary with the sensitivity of one's nose. The period of time until the odor threshold is reached in the exhaust stream can be estimated from Labconco exclusive computerized filter modeling program. Contact Labconco on carbon filter life for specific applications. See Chapter 6.

Saturation Level or Time – There is a limit to the amount of chemical that can be adsorbed by activated carbon, or neutralized by chemically-treated carbon. Once the capacity of the carbon is reached, it is considered to be saturated and will adsorb (or neutralize) no further material; the outlet concentration of the chemical will equal the inlet concentration from that point until the filter is replaced. (Note that the capacity of activated carbon is not a constant, but varies with the inlet concentration). Labconco Technical Specialists can determine with the computerized carbon-modeling program the estimated time saturation for a particular chemical. When using a HEPA filter in all filtered glove boxes or in combination with a carbon filter, the speed control will need to be increased to allow for HEPA filter loading.

IDLH (Immediately Dangerous to Life and Health). An atmosphere that poses an immediate hazard to life or produces immediate irreversible health effects. IDLH concentrations should not be approached in the glove box.

Appropriate Chemicals for Carbon Filters

Below is a general set of rules to determine appropriateness of chemical usage.



Selected organic chemicals considered to be occupational carcinogens by NIOSH can be used in the filtered glove box with carbon filters under rigid restrictions. See separate discussion on carcinogens for special instructions.

Organics must have time weighted exposure limits (TWA) of 1 PPM or greater.

Chemicals must have a detectable odor at concentrations below the TWA for the chemical.

Chemicals must be designated by NIOSH guidelines as acceptable for use with chemical cartridge-type respirators (the exception is formaldehyde and ammonia/amines, which use impregnated carbon). Chemicals not listed by NIOSH in the Pocket Guide must be approved by Labconco Product Specialist (or Engineering).

Inlet concentration must never exceed the IDLH (Immediately Dangerous to Life and Health) concentrations.

Chemicals having a recommendation by NIOSH of at least “Escape GMFOV” (Gas Mask Full-Face Respirator).

When evaporating a mixture of chemicals, the chemical having the lowest TWA will be used to determine if the mixture meets the guidelines.

Call a Labconco Product Specialist at 1-800-821-5525 for assistance in chemical appropriateness.

Hazardous Misapplications for Carbon Filters with Volatile Chemicals

There is one scenario where the accessory FilterMate carbon filter misapplication would be a part of a hazardous condition. If the user continues to operate the glove box with FilterMate Portable Exhauster with any of the following conditions, a potentially hazardous condition will exist:

1. The inlet concentration of vapors is greater than the TWA.
2. The carbon filter becomes saturated.
3. The ventilation of the room is insufficient to dilute the exhaust of the enclosure to below the TWA for the chemical.

When the inlet concentration is greater than the TWA, extra measures must be taken to monitor the filter and number of room air exchanges.

Chemical Carcinogen Use with Carbon Filters

Selected carcinogens may be used safely with accessory FilterMate carbon filters under the following restrictions.



The use of a ventilated glove box with ducting to the outside is always the preferred method when working with carcinogens. The carbon filters should only be used, as a last resort, when venting to the outside is not an option.

The potential carcinogens are listed in the NIOSH Pocket Guide to Chemical Hazards as “Ca.” Each potential carcinogen must have a TWA of 1 or greater; have minimum respirator recommendation of Escape GMFOV, and an odor threshold significantly lower than the TWA for the chemical.

The inlet concentration or the evaporation rate of the chemical must never exceed the TWA for the chemical.

Consult a Labconco Technical Specialist for estimated saturation life. See Chapter 6 for an example of estimating saturation life based on Labconco's chemical guide.

Prohibited Acid Use

The Precise HEPA-Filtered Glove Box and internal metal parts **must** not be exposed to mineral acid use. No exceptions are permitted, as the glove box life span will be limited with acid use.

NOTE: If mineral acids are used with the Precise HEPA-Filtered Glove Box, Labconco makes no claims about life span and warranties will become void.

Chapter 6: Maintaining Your Glove Box

Review this chapter on maintenance for the following:

1. Routine maintenance.
2. Decontamination.
3. Determining when to replace the HEPA filters.
4. How to install new HEPA filters.
5. HEPA filter leak test.
6. Initial certification.
7. Re-certification.
8. Fluorescent light replacement.
9. Motorized impeller replacement.
10. Speed control replacement.

Routine Maintenance Schedule

Weekly

- Wipe down the interior surfaces of the glove box with a disinfectant or cleaner, depending upon the application.
- Using a damp cloth, clean the exterior surfaces of the glove box, particularly the front and top, to remove any accumulated dust.
- Operate the exhaust system, noting the airflow through the glove box to effectively remove a source of visible smoke.

Monthly (or more often as required)

HEPA

- Chart the operating static pressure at a typical speed control setting. Change HEPA filters when the static pressure increases two-fold or speed setting increases two-fold. Guardian™ Jr. Airflow Monitors are available for constant monitoring (see Chapter 7).

Accessory FilterMate Carbon

- While the glove box is filled with the contaminant gas, test filter condition of accessory FilterMate carbon filters using the appropriate gas detector tube at intervals of 20% of the total estimated time. The exception to the 20% recommendation is formaldehyde or any carcinogen or suspected carcinogen. These hazardous chemicals must be checked at least every 10% of the total estimated time. Gas detector tubes for the specific chemicals that are being used in the glove box can be obtained from your laboratory supply dealer (refer to FilterMate manual).

Accessory FilterMate Carbon

- Replace accessory FilterMate carbon filters when chemical breakthrough is indicated by odor, time, detector tube, or for some chemicals, analytical instrumentation.

Annually

- Replace the fluorescent lamps.
- Have the glove box re-certified by a qualified certification technician. See Certification and Recertification in Chapter 6.

Decontamination

When used in conjunction with microbiologicals, the glove box should be decontaminated with formaldehyde gas before:

- Performing maintenance work in contaminated areas
- HEPA filter changes
- Moving the glove box to a new location
- Changing research programs

The procedures for performing a gaseous decontamination are thoroughly outlined in the U.S. Department of Health, Education and Welfare booklet entitled *Formaldehyde Decontamination of Laminar Flow Biological Safety Cabinets*, available from NIH, Division of Safety, Bethesda, MD 20892, call 301-496-2801.

Determining When to Replace HEPA Filters

The HEPA filters in the filtered glove boxes gradually accumulate airborne particulate matter and powders from the enclosure and room. The rate of accumulation will depend upon the cleanliness of the room air, the amount of time the enclosure is operating, and the nature of work being done in the enclosure. In typical installations and usage, the HEPA filters will last two to five years before requiring replacement. Replace HEPA filters if the speed control is adjusted to full speed or if the normal operating speed and/or static pressure is double the original starting point. Replace HEPA filters if it fails the HEPA Filter Leak Test in Chapter 6.

How to Install New HEPA Filters

The Precise HEPA-Filtered Glove Boxes include a true bag-in/bag-out filter disposal system for safely removing the HEPA filter and protecting the worker from toxic powders and particulates (see Figure 6-1, Filter Changing Diagram). The accessory bags can be ordered from Labconco (see Chapter 7). Two bags will be required for each HEPA filter for a total of 4 each to complete the change process. For your safety, wear appropriate personal protective equipment during the change of HEPA filters. If working with micro-biologicals, use the decontamination procedure referenced above. (Consult your Safety Officer before performing filter changes).

1. Turn the glove box OFF. Refer to Appendix A for replacement parts and Appendix B for dimensions.
2. Loosen the six filter nuts that secure each HEPA filter.
3. Place the accessory bag over the HEPA filter and seal to the filter housing.

4. Place both arms in the rear gloves of the bag, and carefully draw the HEPA filter out of the glove box. Rest the HEPA filter on the floor, table or cart. Remove arms from bag gloves.
5. Create two seals between the glove box housing and the old HEPA filter. Seals can be heat sealed or sealed with tie wraps. Cut off the bag between the two seals and leave the bag stub on the access port to the glove box.
6. Place the new HEPA filter in another new bag. Then place the new bag with the new HEPA filter over the old bag stub and onto the glove box filter housing.
7. Carefully remove the old bag from the filter housing using the single glove near the access port. Draw the old bag and stub into the single glove and turn the glove inside out. Double seal this glove on the contaminated bag stub inside. Remove the bag and dispose of properly.
8. Carefully install the new HEPA filter and uniformly tighten the six filter nuts until the HEPA filter gasket is compressed 50%.
9. Turn the glove box ON and proceed to the HEPA Filter Leak Test in Chapter 6.

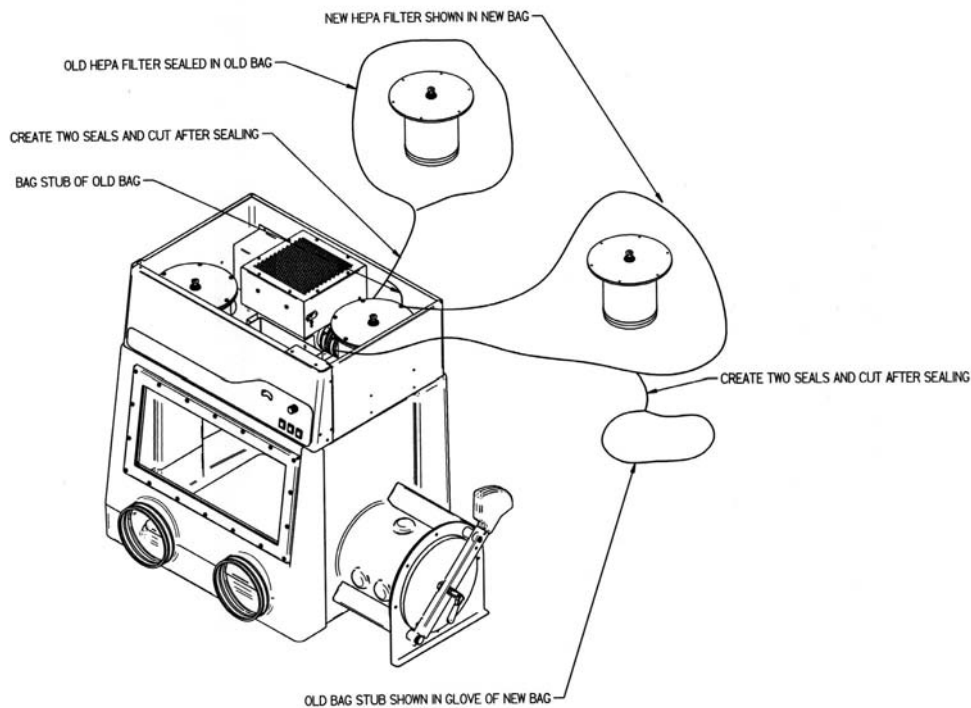

Figure 6-1
HEPA Filter Changing Diagram

HEPA Filter Leak Test

Purpose

This test is performed to determine the integrity of the HEPA filter(s), the filter housing, and the filter mounting frames. The leak test is to be done by a qualified technician with calibrated equipment. Reference Leak Testing and Photometer scanning from the Institute of Environmental Services (IES-RP-CC001.3)

Equipment Required

1. **An aerosol photometer ATI model 2D, 2E, 2G or equivalent.** Air Techniques Hamilton Associates inc. 11403 Cron Ridge Dr. Owings Mills, MD 21117
2. **One aerosol generator of the Laskin nozzle(s) type.** An aerosol of mineral oil or suitable liquid shall be created by flowing air through it. The compressed air supplied to the generator should be adjusted to a pressure as indicated in the procedure. Air Techniques Inc. Model TDA-4A or equal.
3. **Mineral oil** (Labconco P/N 1491400).
4. **Sampling Nozzle, Rectangular 1/2" x 3-1/4"**, Air Techniques, Inc.

Procedure

When Using the ATI 2G Photometer

NOTE: Because the downstream side of the HEPA filters cannot be scanned, a downstream average must be taken.

1. Turn on the photometer and allow it to operate for a minimum of 5 minutes. Leave the valve in the "CLEAR" setting.
2. Press the "ENTER" keypad. Press the "REF" keypad.
3. The display will show "P1" or "P2" for approximately 1 second, and then display a numerical value.
4. Using the "▲" or "▼" keypads, increase or decrease the numerical value, respectively, until it equals 68. (Set for 100 CFM, adjust for other airflows.)
5. Press the "ENTER" Keypad. The photometer will scan for 15 seconds, and then the "0" keypad will flash. Press the "Enter" keypad. The unit will scan for 5 seconds, the display will read "0000," and the unit will sound a confirming tone.
6. Set the valve to "DOWNSTREAM." Place the palm of your hand over the sampling port of the pistol. There should be a strong vacuum at this port. If the vacuum is weak, contact Air Techniques Hamilton Associates.

7. Ensure that the glove box speed control is adjusted to the maximum setting and the blower is exhausting 100 CFM through the glove box.
8. Position the aerosol generator discharge near the internal opening of each HEPA filter. Check both filters.
9. Start the aerosol generator. Ensure that the generator is operating with 1 nozzle on at 10 PSIG.
10. Allow the generator to operate for a minimum of 15 seconds. Place a 1/4" OD sampling tube in the exhaust downstream of the HEPA filters. The inlet HEPA filter can be checked from the test port on the exhaust HEPA filter and the exhaust HEPA filter can be checked from the blower inlet (suction side) test port. Connect this tube to the "downstream" sampling port of the photometer.

Acceptance

The downstream average penetration shall not exceed 0.005 percent as measured by the photometer.

Procedure When Using the ATI 2-D or 2-E Photometer

NOTE: Because the downstream side of the HEPA filters cannot be scanned, a downstream average must be taken.

1. Turn on the photometer and allow it to operate for a minimum 5 minutes. Leave the range switch at "100%" and the valve in the "CLEAR" setting.
2. Use the screw on the face of the gauge to adjust the meter to 0 if necessary.
3. If the "INT REF" switch is a square button, depress it. The switch will remain depressed and illuminated. If the switch is a toggle type switch, push and hold the switch to the "ON" position. Keep this switch in the "ON" position through step 4.
4. Turn the "GAIN" knob until a value of 15 is obtained. (Set for 100 CFM, adjust for other airflows.)
5. Turn the range switch to 0.1. Turn the Stray Light knob until the meter reads "0."
6. Turn the valve to the "DOWNSTREAM" setting. Place the palm of your hand over the sampling port of the pistol. There should be a strong vacuum at this port. Return the valve to the "CLEAR" setting.
7. Ensure that the glove box speed control is adjusted to the maximum setting and the blower is exhausting 100 CFM through the glove box.
8. Position the aerosol generator discharge near the opening of each HEPA filter. Check both filters.
9. Start the aerosol generator. Ensure that the generator is operating with 1 nozzle on at 10 PSIG.
10. Allow the generator to operate for a minimum of 15 seconds. Place a 1/4" OD sampling tube in the exhaust downstream of the HEPA filters. The inlet HEPA filter can be checked from the test port on the exhaust HEPA filter and the exhaust HEPA filter can be checked from

the blower inlet (suction side) test port. Connect this tube to the “downstream” sampling port of the photometer.

Acceptance

The downstream average penetration shall not exceed 0.005 percent as measured by the photometer.

Initial Certification

The Precise HEPA-Filtered Glove Box has been leak tested at the factory with helium gas at positive 1" w.g. pressure; leaks cannot exceed 1×10^{-3} cc/sec. The HEPA Filter Leak Test has been performed at the factory on both HEPA filters with no particulate leaks greater than .005 percent. The filtered glove box should be certified before use for the three tests listed under Re-Certification below. It is also recommended to perform the HEPA Filter Leak Test again should there be any damage caused during transport.

Re-Certification

Under normal operating conditions, the glove box should be re-certified at least annually if serviced. The certifier should perform the following tests.

- Record airflow volume and glove box static pressure. Replace HEPA filters if pressure doubles or airflow is reduced to half the original volume.
- Perform HEPA Filter Leak Test.
- Perform a Smoke Test to determine proper dilution rate inside the glove box. Smoke removal should be completely purged in less than two minutes at full blower speed.

Fluorescent Light Replacement

1. Disconnect the power. Refer to Appendix A for replacement parts.
2. Locate the light reflector located on the top of the glove box behind the front panel.
3. Remove the light reflector support by removing two hex nuts located on both sides of the light reflector.
4. Remove the old fluorescent lamp.
5. Reinstall the new fluorescent lamp and light reflector by reversing the steps above.

Motorized Impeller Replacement

The motorized impeller must be replaced as a complete unit. See Appendix A for replacement parts diagram.

1. Unplug the motorized impeller from the electrical outlet. Refer to Appendix A for replacement parts.
2. Remove the hose connecting the exhaust HEPA filter to the motorized impeller.
3. Remove the motorized impeller and support braces from the light and the rear sheet metal façade.
4. Reassemble the new motorized impeller by reversing the steps above.



WARNING: High-speed blower. Never operate impeller with housing off.

Speed Control Replacement

1. Disconnect the power and remove the cover behind the front control panel where the speed control is located.
2. Remove the two fasteners holding the speed control. Refer to Appendix A for replacement parts.
3. Disconnect all wires leading to the speed control. Connect wires on new speed control in the same position as the old speed control.
4. Reassemble to the system in the same position and with the same fasteners that were removed earlier.

Chapter 7:

Accessorizing Your Glove Box

There are many ways to accessorize and modify the glove box for your individual requirements. These include many different accessories listed in this chapter.

- 1. Black Epoxy Flat Work Surface (Part #4882807)**
A solid epoxy resin 60" x 30" x 1.25" work surface is available to support the glove box.
- 2. 30" Standard Base Cabinet (Part #9900200)**
Two optional base cabinets can be ordered to support the 60" x 30" work surface and glove box. Contact Labconco for additional sizes.
- 3. Adjustable Height Base Stands with Attached Work Surface (Part #5235500 w/casters, Part #5235501 w/adjustable feet)**
These stands, 60" x 31", with attached black laminate work surfaces have an adjustable height range from 33" to 40" and include a lower shelf for supporting accessory equipment.
- 4. Blower Foot Switch (Part #5241600)**
Provides a hands-free means to shut off power to the built-in blower.
- 5. Bag Set for Bag-in/Bag-out HEPA Filter Replacement (Part #5241700)**
Set of two convenience bags and two safety straps for changing and disposing of one HEPA filter safely with a bag-in/bag-out procedure.
- 6. Anti-Static Ionizer Fan (Part #5234400, 100/115V or Part #5234401, 230V)**
Used for weighing operations and attaches to the ceiling of the glove box. The ionizer fan circulates ionized air inside the glove box to reduce static charge. Ionizer Replacement Points (set of 8 emitter electrodes) are ordered separately (Part #5235100). See Appendix D for additional information.
- 7. Balance Vibration Isolator (Part #5234600)**
Isolates building vibration and aids with balance weighing. Includes a 20" x 13" x 2 1/4" marble slab with isolator pads and type 304 stainless steel top cover to protect the porous marble.

8. Pressure Gauge for the Transfer Chamber (Part #5238100)

Kit includes the pressure gauge, hose and fittings to add to the transfer chamber. Range 0 to 29 inches of mercury vacuum.

9. Add-A-Valve Kit (Part #5225701)

Includes the valve, O-ring, and nut to supply the main chamber or the transfer chamber to purge vacuum, fill gas, or connect a drying train. One each Identifier Label Set for valves (Part #5236600) is ordered separately.

10. Vacuum Aspirator Kit

Includes the valve, hose, canister, and vacuum pump for evacuating fluids around the work surface.

Part #	Descriptions
5241800	Vacuum Aspirator Kit, 115V
5241801	Vacuum Aspirator Kit, 230V

11. Electrical Power Strips

These convenience electrical power strips are available in US and international versions and plug into the interior duplex of the glove box.

Part #	Descriptions
5211500	US Power Strip 115V, 4 Position, 5A
5210600	UK Power Strip 250V, 6 Position, 2A
5290400	European Power Strip 250V, 4 Position, 2A
5332600	Australian Power Strip 250V, 6 Position, 2A
5211501	Installation Tool

12. Electrical 9 Pin Sealed Pass-Through Kit (Part #5075619)

Includes sealed 9 pin (D-subminiature with male pins on one side and female pins on the other) connector and cord for data transfer to a typical printer outside the glove box from the balance. Note: Order the 9 pin installation kit separately which includes all the drill bits and hole saws for field installation (Part #5241100).

13. Mechanical or Electrical Straight Pass-Through Kit (Part #5240700)

Provides three ID pass-through ports with sizes of .230/.395, .230/.530, and .450/.705. Order the installation kit with drill bits separately (Part #5240800). Useful for sealing cords and plumbing.

14. FilterMate Portable Exhausters and Filters for Secondary Filtration (see models and filters below)

The FilterMate Portable Exhauster can successfully adsorb low level organic vapors, formaldehyde, ammonia, and secondary particulates via another HEPA filter.

Part #	Descriptions
3970000	115V FilterMate (HEPA only included)
3970020	230V FilterMate (HEPA only included)
3970001	115V FilterMate (Carbon Filter sold separately)
3970021	230V FilterMate (Carbon Filter sold separately)
3970002	115V FilterMate w/thimble (HEPA included)
3970022	230V FilterMate w/thimble (HEPA included)
3970003	115V FilterMate Combination HEPA/Carbon (order Carbon Filter separately)
3970023	230V FilterMate Combination HEPA/Carbon (order Carbon Filter separately)
3970004	115V FilterMate (Two Carbon Filters Sold separately)
3970024	230V FilterMate (Two Carbon Filters sold separately)
3707900	HEPA Filter for FilterMate
3923400	Organic Carbon Filter for FilterMate, 12 lbs.
3923401	Formaldehyde Carbon Filter for FilterMate, 14 lbs.
3923402	Ammonia Carbon Filter for FilterMate, 16 lbs.
3776002	Replacement Bag to Bag-In/Bag-Out HEPA Filter

15. 5" Thimble Exhaust Connector for Connection to the FilterMate (Part #5241900)

Connects to the top of the blower on the glove box for attaching the FilterMate Portable Exhauster. The thimble is necessary for balancing the blower in the glove box with the FilterMate Portable Exhauster.

16. 6" Thimble Exhaust Connection to Building Exhaust (Part #5230200)

Provides a 6" exhaust thimble connection to the blower on the glove box for exhausting to the outside. The thimble is necessary for balancing the blower on the roof with the glove box blower.

17. 6" Hard Duct Connection to House Exhaust (Part #5230400)

Provides a 6" hard duct connection for using a roof-mounted blower and by-passing the blower on the glove box.

18. Remote Wall-Mount Blower Kit (Part #5229800)

Provides a wall-mount bracket, 4" dia. x 6' long hose, hose clamps, and 8' power cord for moving the blower from the glove box and remotely mounting it to a wall within 5'.

19. 6" Exhaust Dampers

Exhaust dampers allow airflow adjustments to be made, maintaining proper airflow to roof-mounted remote blowers or building exhaust.

Part #	Descriptions
3924000	6" Epoxy-Coated Steel In-Line Adjustable Damper
4724200	6" PVC In-Line Adjustable Damper

20. Remote Blowers

Has a 1/4 hp direct drive motor and corrosion-resistant epoxy-coated steel housing and wheel with blower inlet of 6.00" ID. Outlet dimensions are 4.25" x 7.38" OD.

CFM @ Static Pressure-Inches of H ₂ O						
S.P.	0.0"	0.125"	0.25"	0.50"	0.75"	0.87"
CFM	595	560	515	420	300	167

Part #	Description
4863500	Remote Blower, 115 V, 60 Hz. 4.4 amps
4863501	Remote Blower, 115/230 V, 50 Hz, 5.6/2.8 amps

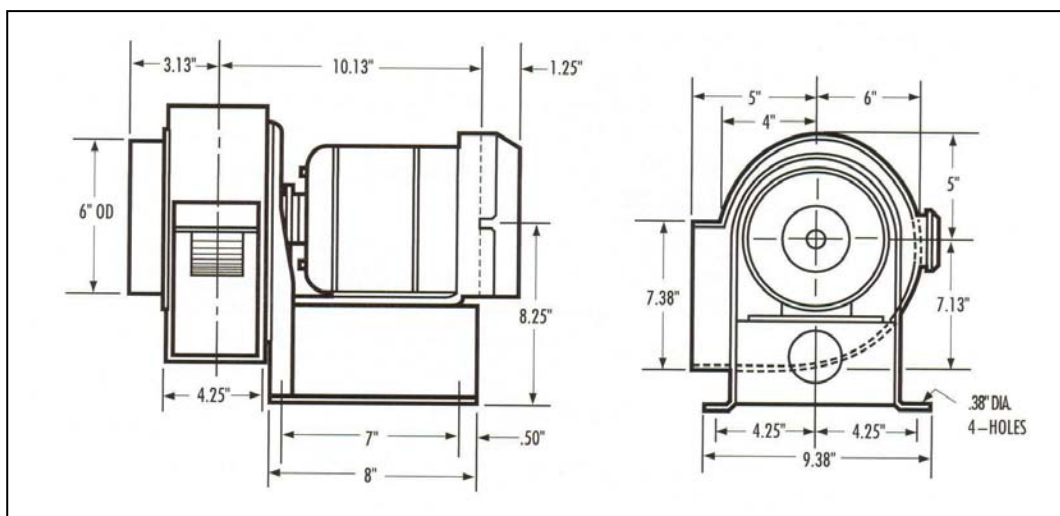

All dimensions in inches

21. Positive Pressure Conversion Kit (Part #5236900)

Converts integral glove box blower from negative pressure operation to positive pressure.

22. Recirculation Kit (Part #5236500)

Allows the blower exhaust to be connected to the HEPA inlet filter for recirculation of the exhaust air. Useful with drying train components on the main chamber.

23. Filtration Components for Moisture and Fume Removal

The following components are useful in removing organics, acids, ammonia, moisture, and other gases as indicated. They are connected to the glove box using the #5225701 Add-A-Valve Kit.

Part #	Descriptions
5248200	Vacuum Pump for Circulation, 115V, 60 Hz w/switch
5248201	Vacuum Pump for Circulation, 230V, 50 Hz
7815301	Canister with Stand for Traps
7815200	Moisture & Solvent Trap Insert (molecular sieve)
7814800	Acid Vapor Trap Insert
7815000	Radioisotope Trap Insert

Part #	Descriptions
7995600	Ammonia Trap Insert
5244100	Flowmeter, Visual
5240100	Gas & Vacuum 0.2 Micron Filter

24. Acrylic Viewing Window with Frame (Part #5236100)

Acrylic window, 1/2" thick, for those users that prefer acrylic over the standard laminated safety glass (includes metal frame).

25. Guardian Jr.™ Airflow Monitor (Part #5242000)

Audio and visual airflow monitor is especially useful for installations that exhaust to the outside as it provides feedback on the roof-mounted blower status. Monitor mounts to the top of the control panel.

26. Interior Storage Shelf Kits

Provide convenient storage in the rear or the left side of the glove box to maximize space. Additional hanging shelf kits (sold separately) can hang from the rear interior shelf kit. Each shelf kit adds 240 square inches of usable space. Will support a large 15.2" x 4.8" x 3.7" tissue box.

Part #	Descriptions
5235000	Rear Storage Shelf Kit
5235001	Side Storage Shelf Kit

27. IV Bar Kit (Part #5242100)

Provides a bar for supporting IV bags. Must be used with one of the interior storage shelf kits 5235000 or 5235001.

28. External Glove Port Caps (Part #5242200)

Cap and clamp attaches to the glove ports to eliminate glove inflation during dilution or venting operations. Sold as a set of two.

29. Hanging Shelf Kits

All shelves require the 5235000 rear interior storage shelf kit to function.

Part #	Descriptions
3925000	Consists of three utility shelves (coated steel)
3927700	Bottle Holder (coated steel)
3927800	Tissue Holder (coated steel)
5247300	Bin Organizer, 5.4" (plastic)
5247301	Bin Organizer, 7.4" (plastic)

30. DOP Test Kit for HEPA Filters (Part #5242400)

Includes the connections and hoses to carry out the HEPA Filter Leak Test documented in Chapter 6 of this manual.

31. Drying Train Tubing Kit

Includes the (FEP) tubing and plumbing fittings for connecting typical moisture, and other gas fume removal components (see item 23 above). Fluorinated ethylene-propylene (FEP) tubing has very low moisture absorption.

Part #	Descriptions
5242500	Drying Train Tubing Kit; Moisture, Solvents, and Radioisotopes

32. HEPA and ULPA Filters

HEPA filters come standard with the glove box. ULPA filters may be substituted as an upgrade.

Part #	Descriptions
5225105	Replacement Standard HEPA Filter, 99.99% efficient on 0.3 micron particles
5225106	Optional ULPA Filter, 99.999% efficient on 0.3 micron particles

33. Gloves (see *Appendix A: Replacement Parts for glove sizes and material types*)

Neoprene gloves are the most resistant to abrasion and tearing. Butyl gloves provide higher impermeability and improved dexterity. Hypalon gloves are made with a mixture of neoprene and butyl rubber to provide an intermediate level of neoprene and butyl features.

34. Transfer Chamber High Vacuum Sleeve (Part #5236200)

An internal steel reinforced transfer chamber sleeve is **required** if a vacuum will be pulled in the transfer chamber.

35. Waste Chute (Part #5245800)

The glove box can be configured to add a waste chute from which a waste bag can hang. Waste bags and bands can be ordered from your laboratory dealer. The minimum waste bag size is 8.5" wide.

36. Exterior Transfer Chamber Shelf (Part #5245900)

A powder-coated steel shelf, 10.7" wide x 15.1" deep, can be attached to the top of the transfer chamber. The exterior transfer chamber shelf maximizes work area, useful for printers, laboratory supplies, and notebooks.

Chapter 8: Troubleshooting

Refer to the following table if the Precise HEPA-Filtered Glove Box fails to operate properly. If the suggested corrective actions do not solve your problem, contact Labconco for additional assistance.

PROBLEM	CAUSE	CORRECTIVE ACTION
Blower won't operate.	Unit not plugged into outlet.	Plug the glove box into appropriate electrical service.
	Circuit breaker(s) or Ground Fault Interrupter.	Reset circuit breaker.
	Blower wiring is disconnected.	Inspect blower wiring per wiring diagram on unit.
	Blower switch is defective.	Replace switch if no voltage at blower.
	Motorized impeller or blower is defective.	Replace motorized impeller or blower. See Chapter 6.
Blower and lights won't operate.	Unit not plugged into outlet.	Plug unit into appropriate electrical service.
	Circuit breaker(s) tripped.	Reset or replace circuit breaker.
Lights do not work.	Lamp not installed properly.	Inspect lamp installation.
	Lamp wiring disconnected.	Inspect lamp wiring.
	Defective lamp.	Replace lamp.
	Light switch is defective.	Replace light switch.
	Defective electronic ballast.	Replace ballast.

Appendix A: Replacement Parts

The components that are available for the Precise HEPA-Filtered Glove Box are listed. The parts shown are the most commonly requested. If other parts are required, please contact Product Service.

Item	Qty.	Part Number	Description
1A	1ea	5232200	Framed Glass Window (standard)
1B	1ea	5236100	Framed Acrylic Window (optional)
2A	1ea	1230700	Receptacle, 115V Duplex
2B	1ea	1283900	Receptacle, 230V Duplex
2C	1ea	5232900	Sealed Duplex, 115V Complete
2D	1ea	5232901	Sealed Duplex, 230V Complete
2E	1ea	5233400	Wallplate Duplex Gray
3A	1pr	1640600	9 ¾ size Neoprene Gloves (standard)
3B	1pr	1640601	9 ¾ size Butyl Gloves
3C	1pr	1640602	9 ¾ size Hypalon Gloves
3D	1pr	1640500	8 ½ size Neoprene Gloves
3E	1pr	1640501	8 ½ size Butyl Gloves
3F	1pr	1640502	8 ½ size Hypalon Gloves
3G	2ea	1640000	O-Rings
3H	2ea	1965600	Clamp – O-Ring Gloves
4	1ea	1952500	Pressure Differential Gauge
5	1ea	1307000	Switch, Rocker (2 Position)
6A	1ea	3704402	Blower Speed Control, 115V
6B	1ea	1931500	Knob, Speed Control
6C	1ea	5229400	Extension, Speed Control
6D	2ea	1890302	Set Screw, Extension #8-32 x .12"
6E	1ea	3704403	Blower Speed Control 230V
7A	2ea	5225105	HEPA Filter 99.99%
7B	2ea	5225106	ULPA Filter 99.999%
7C	1ea	5241700	Bag-In/Bag-Out Kit
7D	12ea	1905617	Nut, Keps #10-24
8A	1ea	5227300	Motorized Impeller, 115V (also used on 100V units)
8B	1ea	5227301	Motorized Impeller, 230V
9A	1ea	5222700	Fluorescent Bulb, 8" Circleline FC8T9/CW, 22 Watt, 4 Pin
9B	1ea	5222800	Ballast, 115V 60 Hz
9C	1ea	5222801	Ballast, 230V 50 Hz (also used on 100V, 50 Hz)
9D	1ea	5222802	Ballast, 230V 60 Hz (also used on 100V, 60 Hz)
9E	1ea	5242900	Transformer, 230V to 100V (100V models only)
10A	1ea	1305800	Inlet Power Cord, 115V
10B	1ea	1305900	Inlet Power Cord, 230V
11A	1ea	5226400	Inner Transfer Door w/attached gasket
11B	1ea	5226500	Outer Transfer Door w/attached gasket
12A	1ea	1327204	Circuit Breaker, 5A, 115V
12B	4ea	1327205	Circuit Breaker, 2A, 230V
12C	1ea	1327200	Circuit Breaker, 3A, 115V
13A	REF.	5226900	Wiring Diagram, 115V
13B	REF.	5226901	Wiring Diagram, 230V

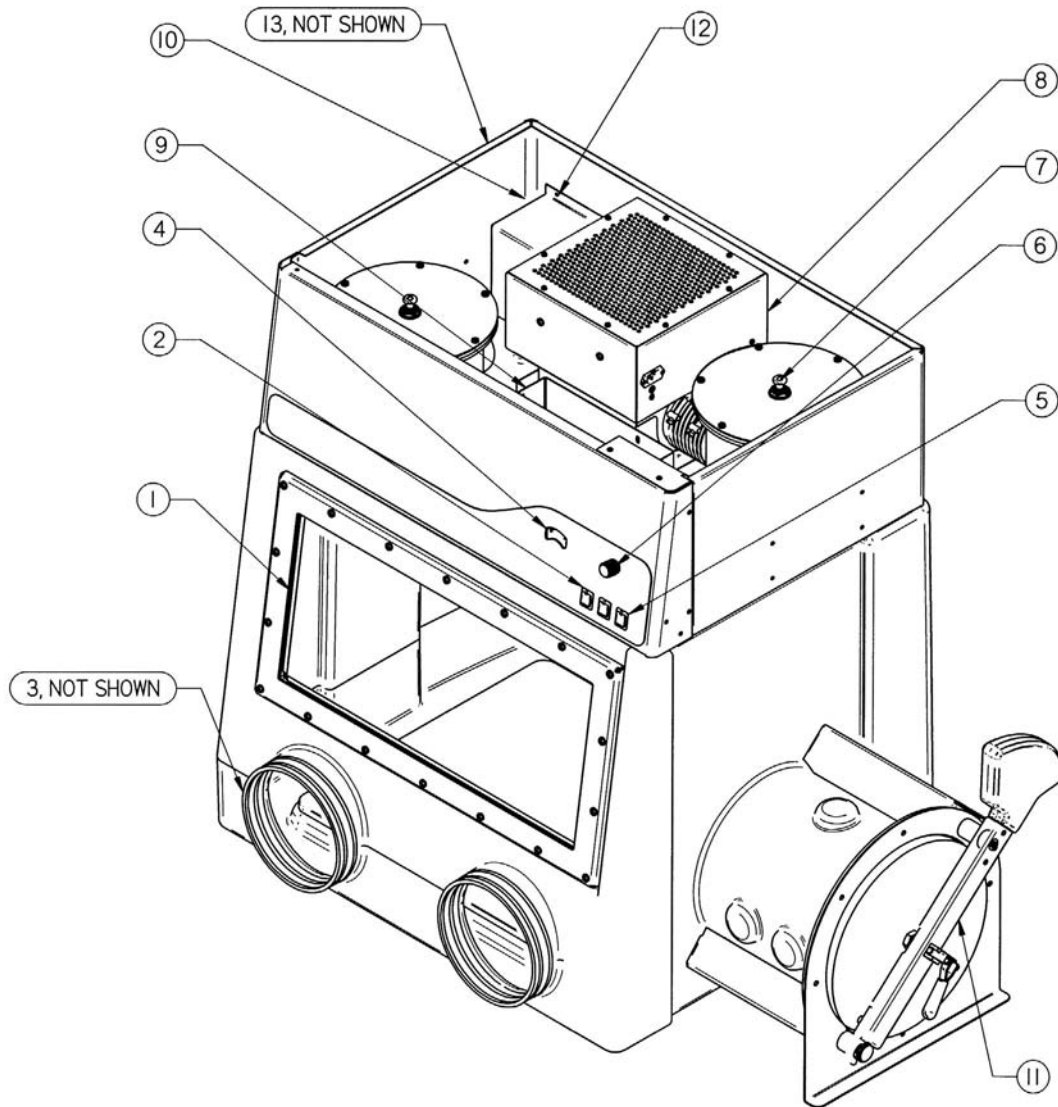

Figure A-1
Replacement Parts for Precise HEPA-Filtered Glove Box

Appendix B: Dimensions

See the following dimensions and exhaust options for the Precise HEPA-Filtered Glove Boxes. All dimensions are in inches.

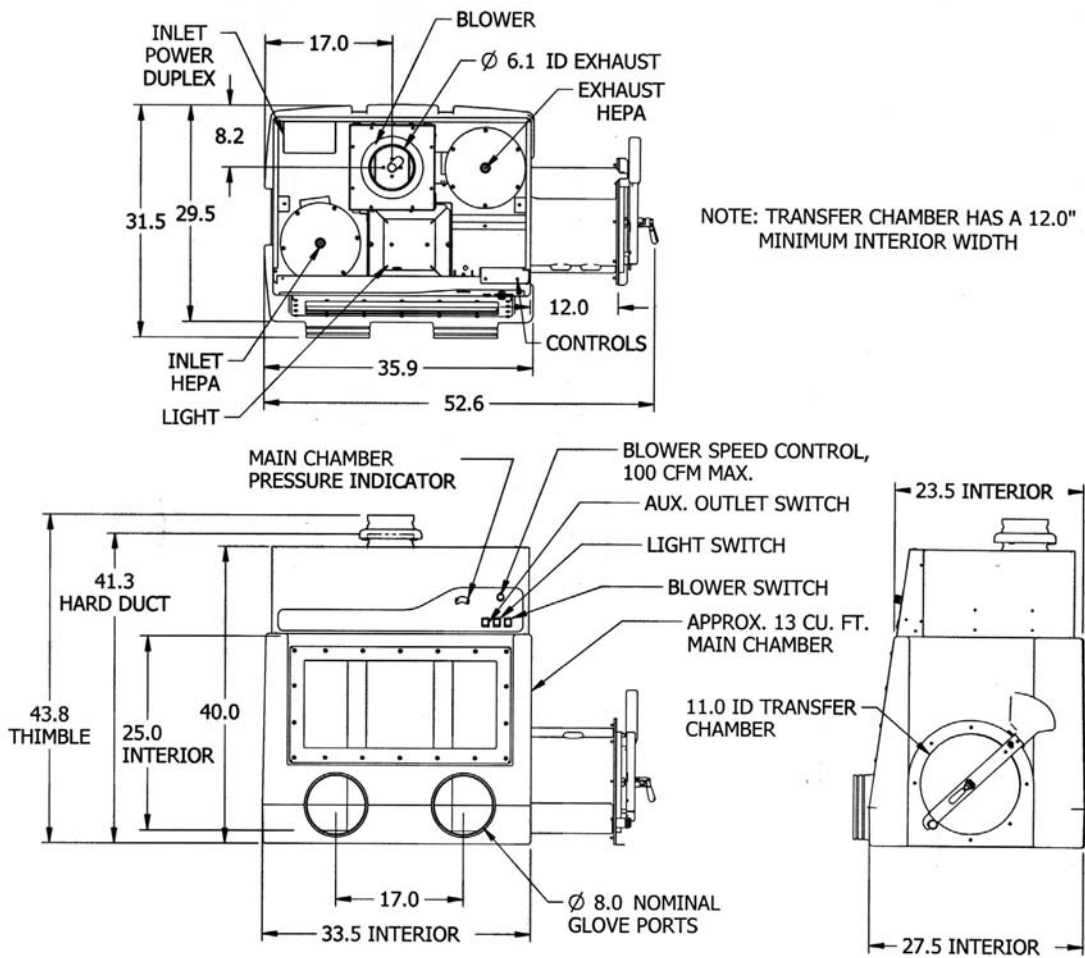

Figure B-1

Appendix C: Specifications

This Appendix contains technical information about all the glove boxes including electrical specifications and environmental operating conditions.

- 8 Amps, 115V, 50/60 Hz or 4 Amps, 230V, 50/60 Hz or 8 Amps, 100V, 50/60 Hz, Precise HEPA-Filtered Glove Box.

Environmental Conditions

- Indoor use only.
- Maximum altitude: 6562 feet (2000 meters).
- Ambient temperature range: 41° to 104°F (5° to 40°C).
- Maximum relative humidity: 80% for temperatures up to 88°F (31°C), decreasing linearly to 50% relative humidity at 104°F (40°C).
- Main supply voltage fluctuations not to exceed $\pm 10\%$ of the nominal voltage.
- Transient over-voltages according to Installation Categories II (Over-voltage Categories per IEC 1010). Temporary voltage spikes on the AC input line that may be as high as 1500V for 115V models and 2500V for 230V models are allowed.
- Used in an environment of Pollution degrees 2 (i.e., where normally only non-conductive atmospheres are present). Occasionally, however, a temporary conductivity caused by condensation must be expected, in accordance with IEC 664.

Appendix D: Ionizer Fan Performance Criteria

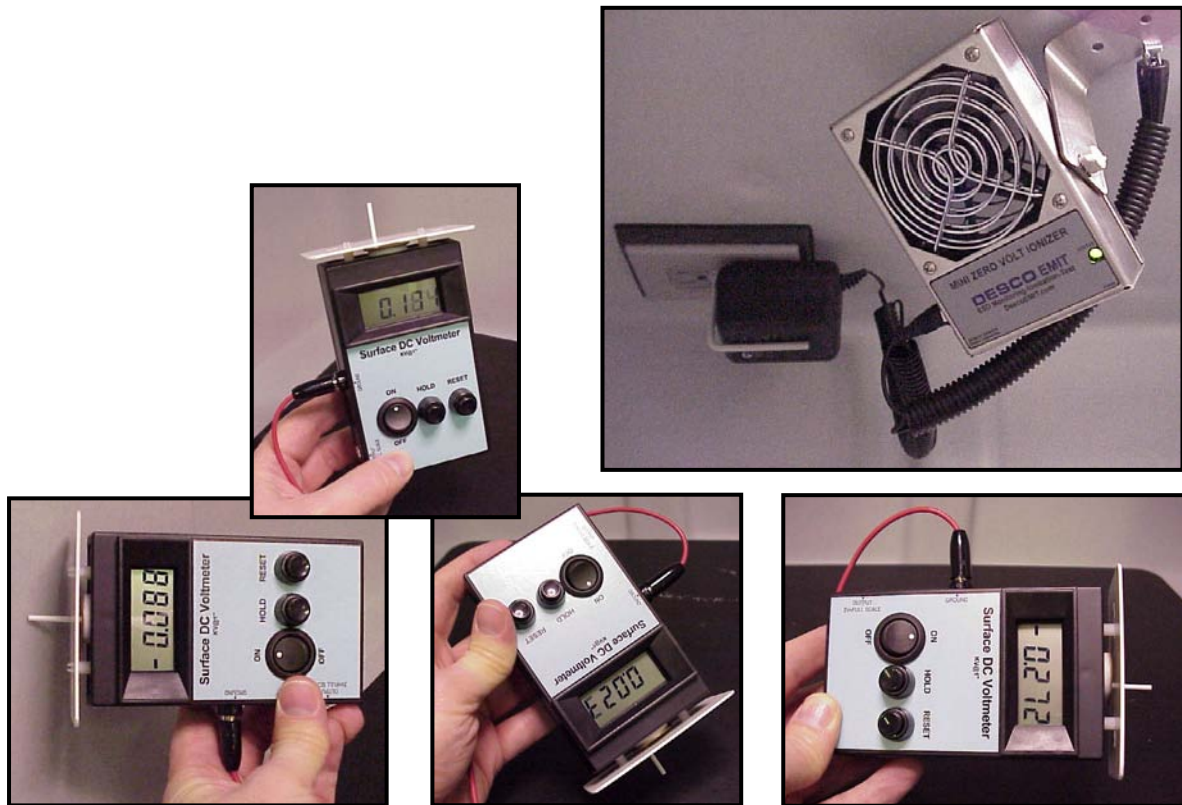

Static Electricity Test

The tests were performed by monitoring the level of static electricity found on the work surface and interior surfaces within the glove box. Static electricity levels were measured with an AlphaLab Surface DC Voltmeter http://scientificmeter.com/surface_dc.htm. A DESCO Emit Mini Zero Volt Ionizer <http://www.descoemit.com/ViewProduct.aspx?pid=50661&h=1323> was installed in the glove box. The DESCO ionizer is a dual steady state DC auto balancing bench top ionizer. The ionizer helps to neutralize static electricity on surrounding surfaces. The time required by the ionizer to neutralize static electricity will be the shortest when objects are within 12" to 36" directly in front of the ionizer. The time for neutralization increases as the distance from the ionizer increases. The time required for sufficient electrostatic decay will also vary depending upon user application, moisture levels within the supply air and the level of cleanliness within the glove box interior.

	Test Point Locations and Voltage Levels							
	Metal Housing Inlet HEPA	Metal Housing Exhaust HEPA	Metal Transfer Chamber Handle	Back Interior Surface	Left Interior Surface	Right Interior Surface	Interior Lamp Window	Center Work Surface
Electrostatic with Glove Box Blower & Ionizer Fan OFF	+ 420	+ 220	+ 734	+ 375	+ 106	+ 151	+ 242	+ 153
100 CFM Blower & Ionizer Fan ON After 1 Hour	+ 96	+ 114	+ 290	+ 93	+ 45	+ 52	+ 46	+ 35
100 CFM Blower & Ionizer Fan ON After 2 Hours	+ 28	+ 58	+ 51	- 52	- 15	- 20	- 28	- 22

**Static Electricity Test Results (VOLTS) on the Glove Box
(Neutralization is best between +/-100V)**

The mini zero volt ionizer’s neutralization time will be shortest when objects are approximately 12" to 36" directly in front of the ionizer and will increase as the distance from the ionizer increases. Set the fan speed switch on the side of the ionizer to the LOW or HIGH position. Higher airflow will result in faster neutralization rates. Position the ionizer so that the maximum airflow is directed at the items or area to be neutralized. The LED will turn on during power up and remain GREEN during normal operation. The ionizer has a grounding jack and must have a good earth ground to maintain proper balance. Always plug the AC power adaptor into the ionizer and then into the appropriate AC power source. The ionizer has no On/Off switch so it should be running as soon as it is plugged in. The ionizer is designed to run off of 24VDC ±10% 300mA.

The balance adjustment for the ionizer can be accomplished by inserting a small screwdriver or trimmer adjustment tool into the balance adjustment hole located on the side of the unit. To increase the output in a positive direction, turn the potentiometer in a clockwise direction. Conversely, to increase the output in a negative direction, turn the potentiometer in a counter clockwise direction. It is recommended that you use a surface DC voltmeter when adjusting the balance of the ionizer.

Under normal conditions, the ionizer will attract dirt and dust (especially on the emitter electrodes). To maintain optimum neutralization efficiency and operation, cleaning with isopropyl alcohol should be performed on a regular basis. If the performance of the ionizer degrades because of dirty or corroded points, the LED on the front of the unit will turn YELLOW; the audible alarm will sound continuously. Under this condition, the unit is not able to maintain balanced ionization. The input power cord must be disconnected before the unit is opened for maintenance. The emitter electrodes should be cleaned using the alcohol cleaners included or a swab wet with isopropyl alcohol. Unscrew the 4 screws on the back of the unit and then remove the screen. After cleaning the emitter electrodes, reinstall the screen and 4 screws. The emitter electrodes should not require replacement during the life of the unit with normal handling. Verify the balance of the ionizer with a surface DC voltmeter after cleaning.

Appendix E: Conversions

Pressure Conversions

To From	mmHg	in.Hg	in.H ₂ O	ft.H ₂ O	atm	lb/in. ²	Kg/cm ²	kPa	bar
mmHg	1	.03937	.5353	.04461	.00132	.01934	.00136	.1333	.0013
in.Hg	25.40	1	13.60	1.133	.03342	.4912	.03453	3.387	.0339
in.H ₂ O	1.868	.07355	1	.08333	.00246	.03612	.00254	.2490	.0025
ft.H ₂ O	22.42	.8826	12	1	.02950	.4334	.03048	2.988	.0299
atm	760	29.92	406.8	33.90	1	14.70	1.033	101.3	1.013
lb/in. ²	51.71	2.036	27.69	2.307	.06805	1	.07031	6.895	.0689
Kg/cm ²	735.6	28.96	393.7	32.81	.9678	14.22	1	98.05	.981
kPa	7.500	.2953	4.016	.3347	.00987	.1451	.0102	1	.01
bar	750	29.53	401.6	33.47	.987	14.51	1.02	100	1

Flow Rate Conversions

To From	lit/sec	gal/min	ft ³ /sec	ft ³ /min	bbl/hr	bbl/day
lit/sec	1	15.85	0.03532	2.119	22.66	543.8
gal/min	0.06309	1	0.00223	0.1337	1.429	34.30
ft ³ /sec	28.32	448.8	1	60	641.1	1.54x10 ⁴
ft ³ /min	0.4719	7.481	0.01667	1	10.69	256.5
bbl/hr	0.04415	0.6997	0.00156	0.09359	1	24
bbl/day	0.00184	0.02917	6.50x10 ⁻⁵	0.00390	0.04167	1

Appendix F: References

Many excellent reference texts and booklets are currently available. The following is a brief listing:

Pharmaceutical Isolators, A Guide to their application design and control. Pharmaceutical Press 2004, Editors: Midcalf, Phillips, Neiger, and Coles.

Isolation Technology, A Practical Guide, 2004 CRC Press, 2nd Edition, www.crcpress.com

International Standard ISO 10648-2 Containment Enclosures

- Classification according to leak tightness and associated checking methods.

International Standard ISO 14644-7 Clean Rooms and associated controlled environments

- Separate devise such as glove boxes and isolators.

NIOSH Pocket Guide to Chemical Hazards
U.S. Dept of Health and Human Resources
Centers for Disease Control and Prevention
National Institute for Occupational Safety and Health

DECLARATION OF CONFORMITY

Application Council Directive(s): 73/23/EEC, 89/336/EEC, 2002/95/EC (ROHS),
2002/96/EC (WEEE)

Standard(s) to which conformity is declared: EN61010-1, EN61326-1

Manufacturer's Name: Labconco Corporation

Manufacturer's Address: 8811 Prospect Avenue
Kansas City, MO 64132 USA

Importer's Name: See Shipping/Customs Documents

Importer's Address: See Shipping/Customs Documents for your equipment

Type of Equipment: Laboratory Equipment Precise Glove Boxes

5220000 Series Precise Basic Glove Box
5220100 Series Precise Controlled Atmosphere Glove Box
5220200 Series Precise HEPA-Filtered Glove Box
5220300 Series XPert Weigh Box

Serial No.: Various – See Individual Declaration

Year of Manufacture: 2006 and subsequent

I, the undersigned, hereby declare that the equipment specified above conforms to the
above Directive(s) and Standard(s).

See individual Declaration of Conformity which
will be signed by the importer for your country.

Place:

(Signature)

Date:

(Full Name)

(Position)