

New Methodologies for BioAPI Conformance Testing

2-4/Mar/2010
Oki Software Co., Ltd.
Toshi Nakamura

Table of Contents

1. BioAPI, BIP and CTS
2. New testing methodologies
3. Expected advantages
4. Grand design for new CTS
5. Future Actions
6. Summary

1. BioAPI, BIP and CTS (1/3)

(1) BioAPI (Biometric Application Programming Interface)

International Standard Interface for Biometrics (ISO/IEC 19784)

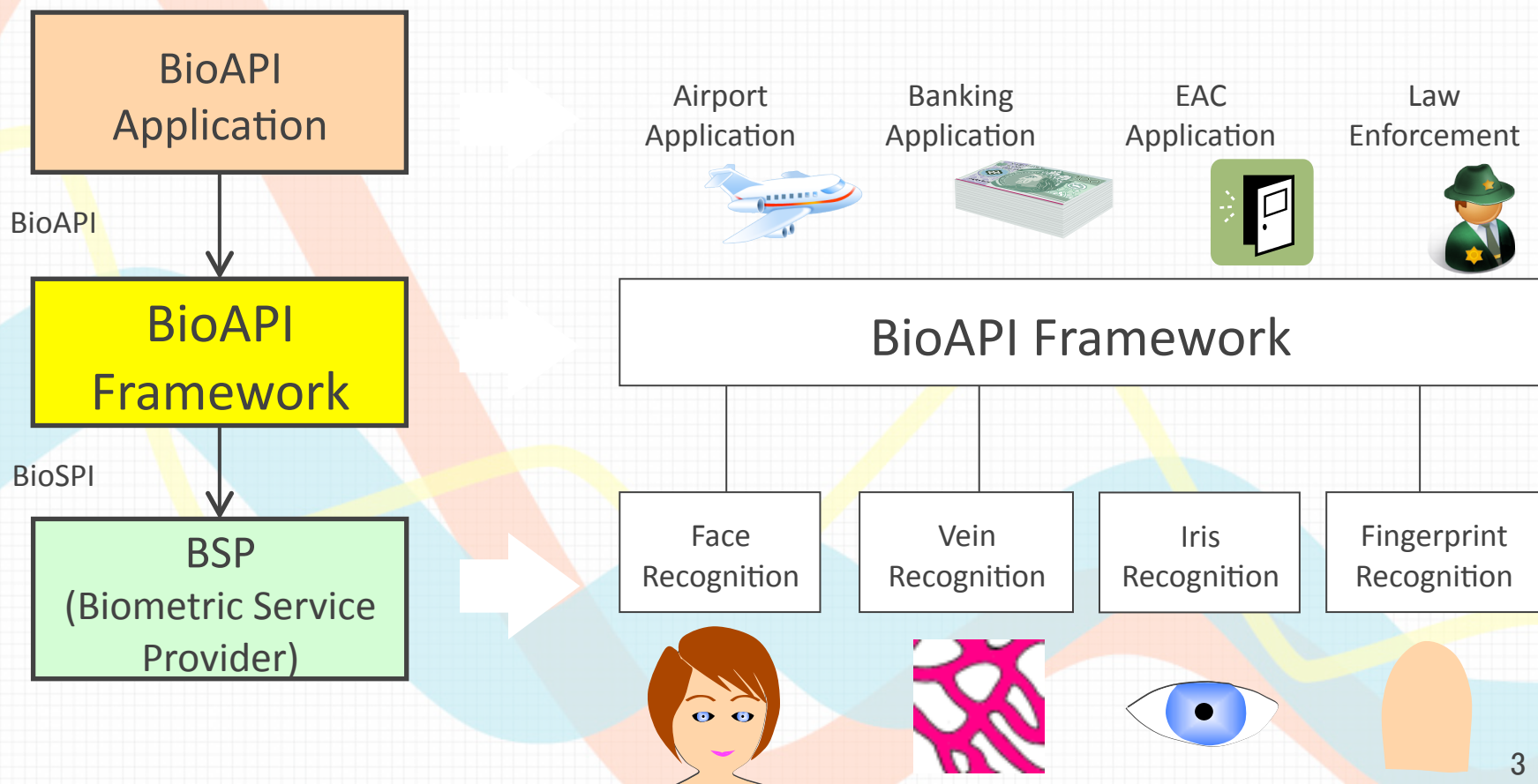

1. BioAPI, BIP and CTS (2/3)

(2) BIP (BioAPI Interworking Protocol)

Network protocol specification for BioAPI (ISO/IEC 24708, ITU-T X.1083)

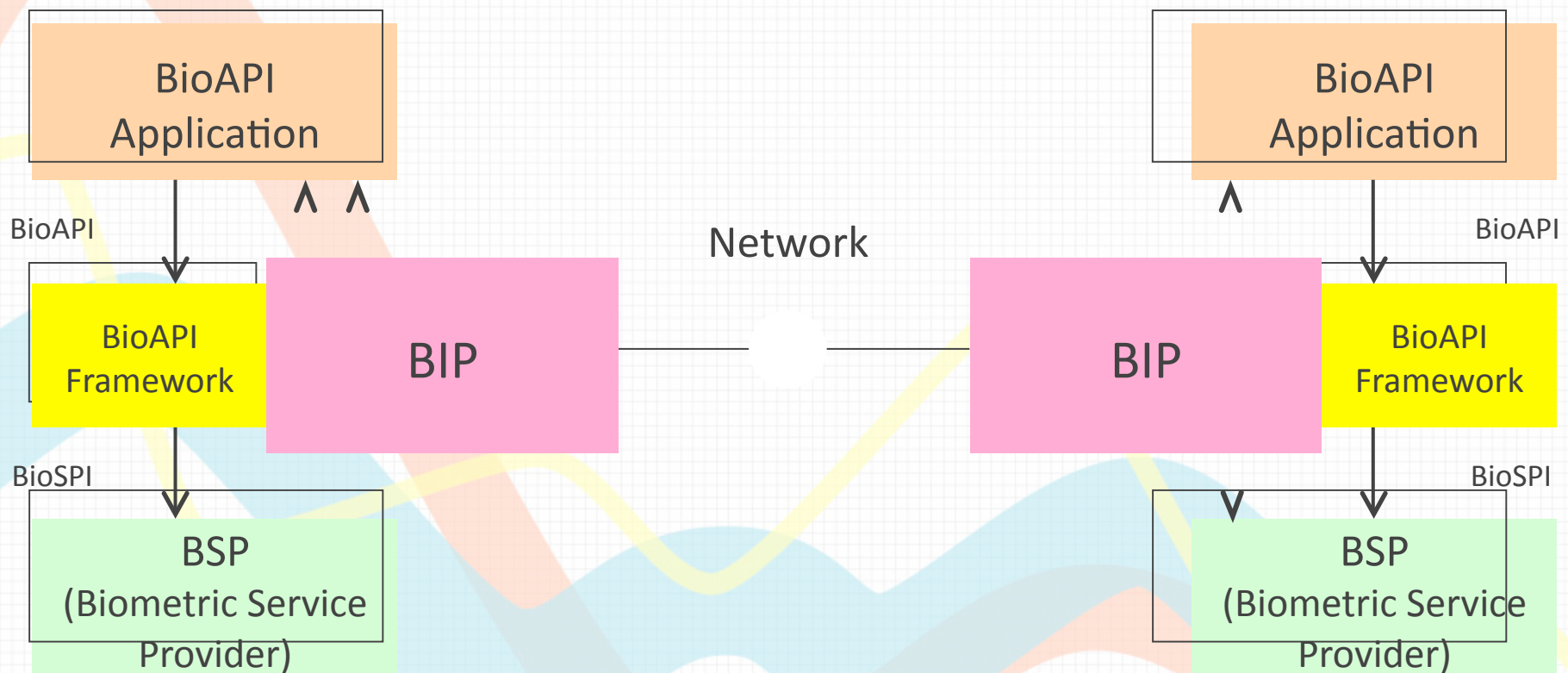

1. BioAPI, BIP and CTS (3/3)

(3) CTS (Conformance Test Suite)

Testing Tools for the software components in BioAPI

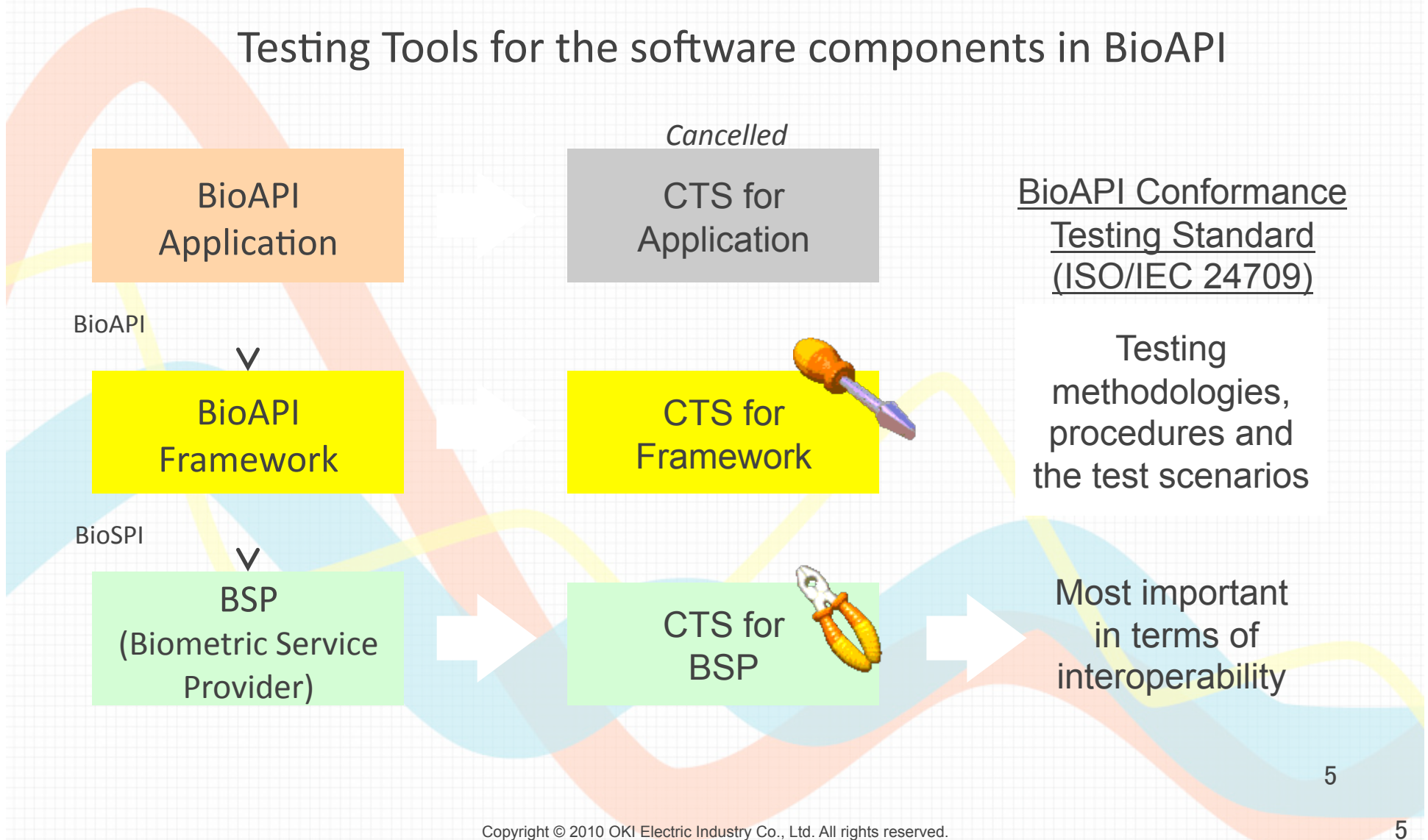

2. New testing methodologies (1/4)

(1) Current methodology of CTS

Current methodology of the CTS for BSP
(described in ISO/IEC 24709)

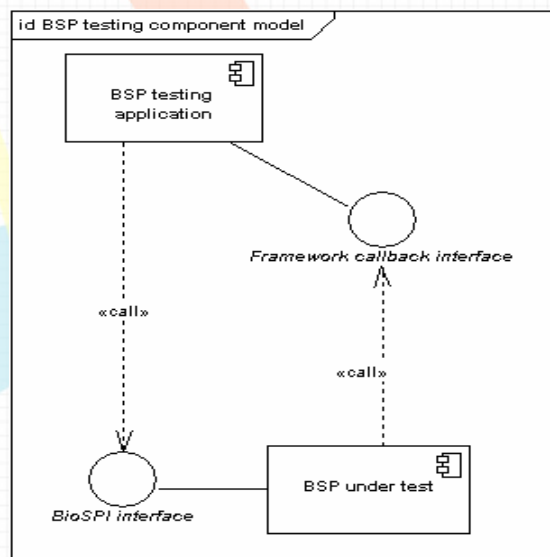

Simplified Diagram

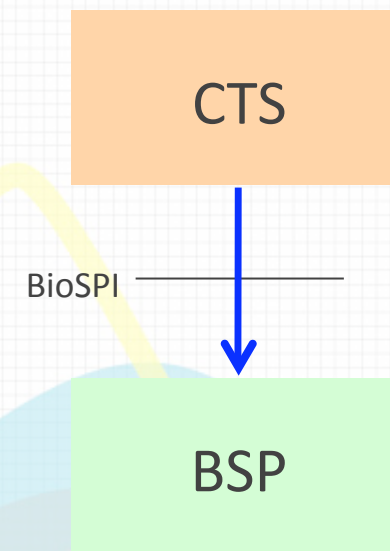

2. New testing methodologies (2/4)

(2) New Methodology #1: CTS coupled with Framework (1/2)

Current Methodology
(ISO/IEC 24709)

CTS

BioSPI

BSP

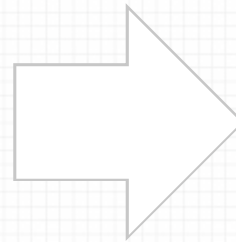

New Methodology #1

BSP is tested by the combination of
CTS and Framework

CTS

BioAPI

Framework

BioSPI

BSP

2. New testing methodologies (3/4)

(2) New Methodology #1: CTS coupled with Framework (2/2)

1. Reduces the volume of development efforts:

No need to develop Initialization, Termination and Component Registry Management, all of which can be provided by the Framework.

2. Makes it easier to develop CTS:

With using the BioAPI SDK, CTS can be developed as one of the BioAPI applications.

3. Almost no influence on the test:

Most of the parameters given from the CTS to the BSP are passed through the Framework without any change.

Note) The reliability of Framework has to be tested and confirmed (See Appendix-1)

2. New testing methodologies (4/4)

(3) New Methodology #2: Expansion with BIP

New Methodology #2

CTS

CTS does not need to care about the existence of BIP
(Even if the BSP is running on a different PC,
it is not necessary to modify the CTS)

BioAPI

Framework

BIP

BIP

Framework

BioSPI

BSP

BioSPI

BSP

Note) The reliability of Framework and BIP have to be tested and confirmed (See Appendix-1)

9

3. Expected Advantages (1/7)

(1) Multiple-Platform Support

(2) Remote Product Certification

(3) Opportunities to showcase the achievements of standardization

3. Expected Advantages (2/7)

(1) Multiple-Platform Support (1/2)

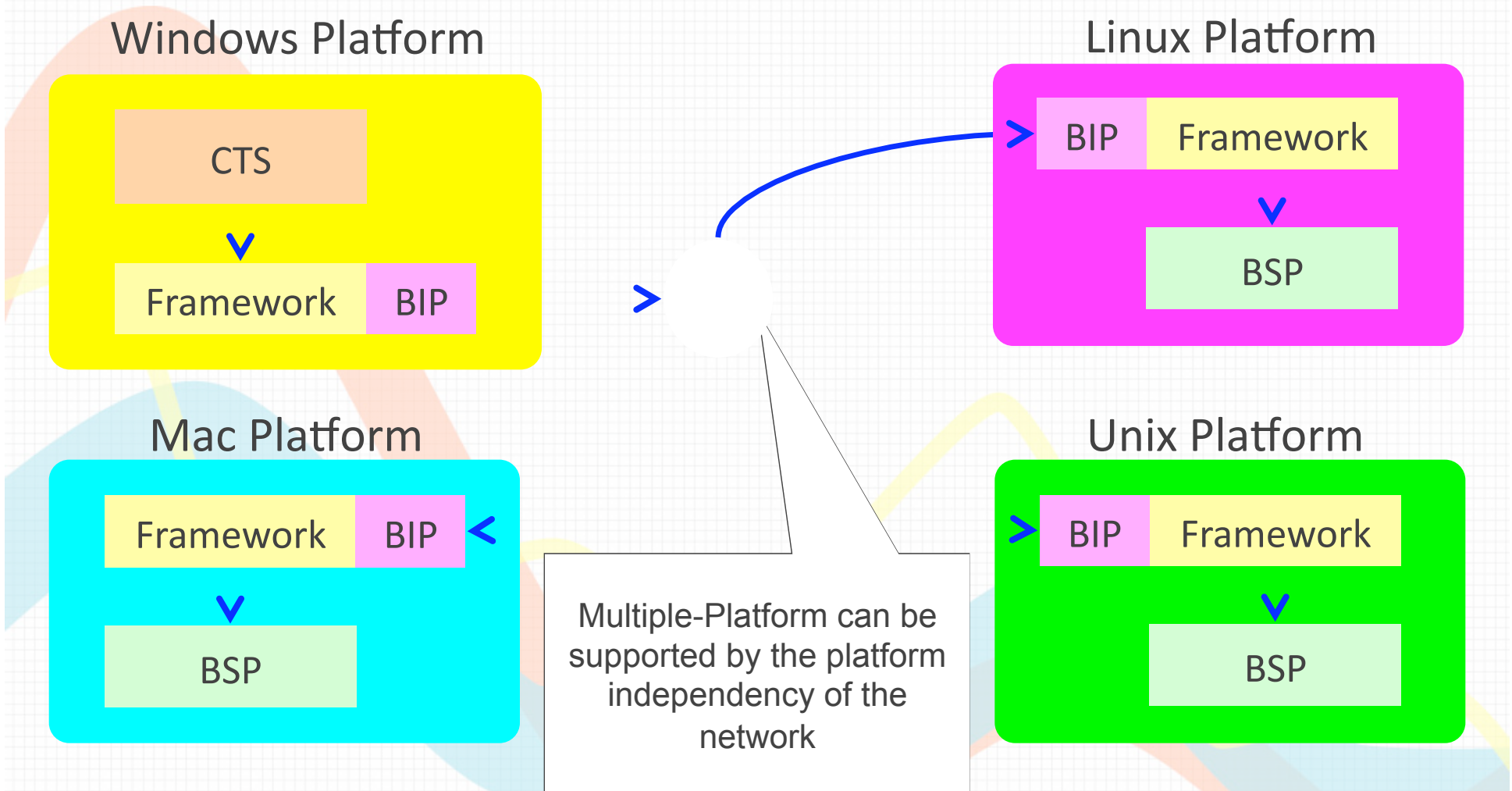

3. Expected Advantages (3/7)

(1) Multiple-Platform Support (2/2)

1. The BioAPI components on various operating systems should have an equal opportunity to be tested and certified.
2. As for the development of CTS, you only need the knowledge of one platform (such as Windows).
3. The operation of the conformance testing organization can be simplified; the initial and maintenance cost can be reduced.

Multiple-platform support can facilitate the product interoperability among different platforms.

3. Expected Advantages (4/7)

(2) Remote Product Certification (1/2)

- Prepares for the test
- Follows the instructions on screen (If a capture is requested, a test subject presents his/her biometric information)
- Receives a report from the Certification Authority

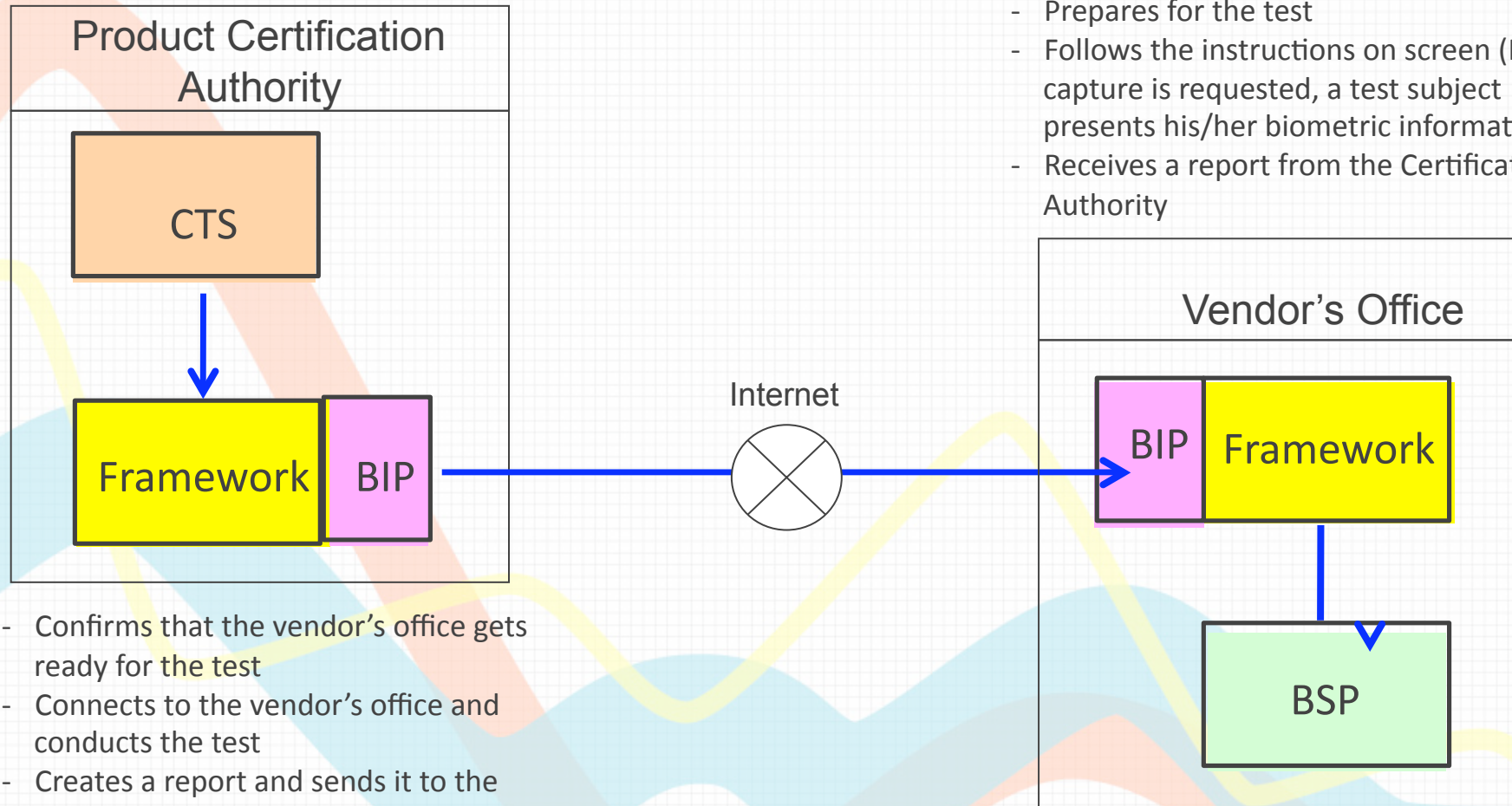

- Confirms that the vendor's office gets ready for the test
- Connects to the vendor's office and conducts the test
- Creates a report and sends it to the vendor

3. Expected Advantages (5/7)

(2) Remote Product Certification (2/2)

1. By the Remote Product Certification, you can be certified without visiting CA (Certification Authority). It can provide low-cost and convenient services to vendors.
2. Not all the countries could open and run the product certification authority – in the countries without CA, vendors have to go abroad to get certified.

Remote Product Certification can facilitate the product interoperability, even globally.

3. Expected Advantages (6/7)

(3) Showcase of standardization achievements
(1/2)

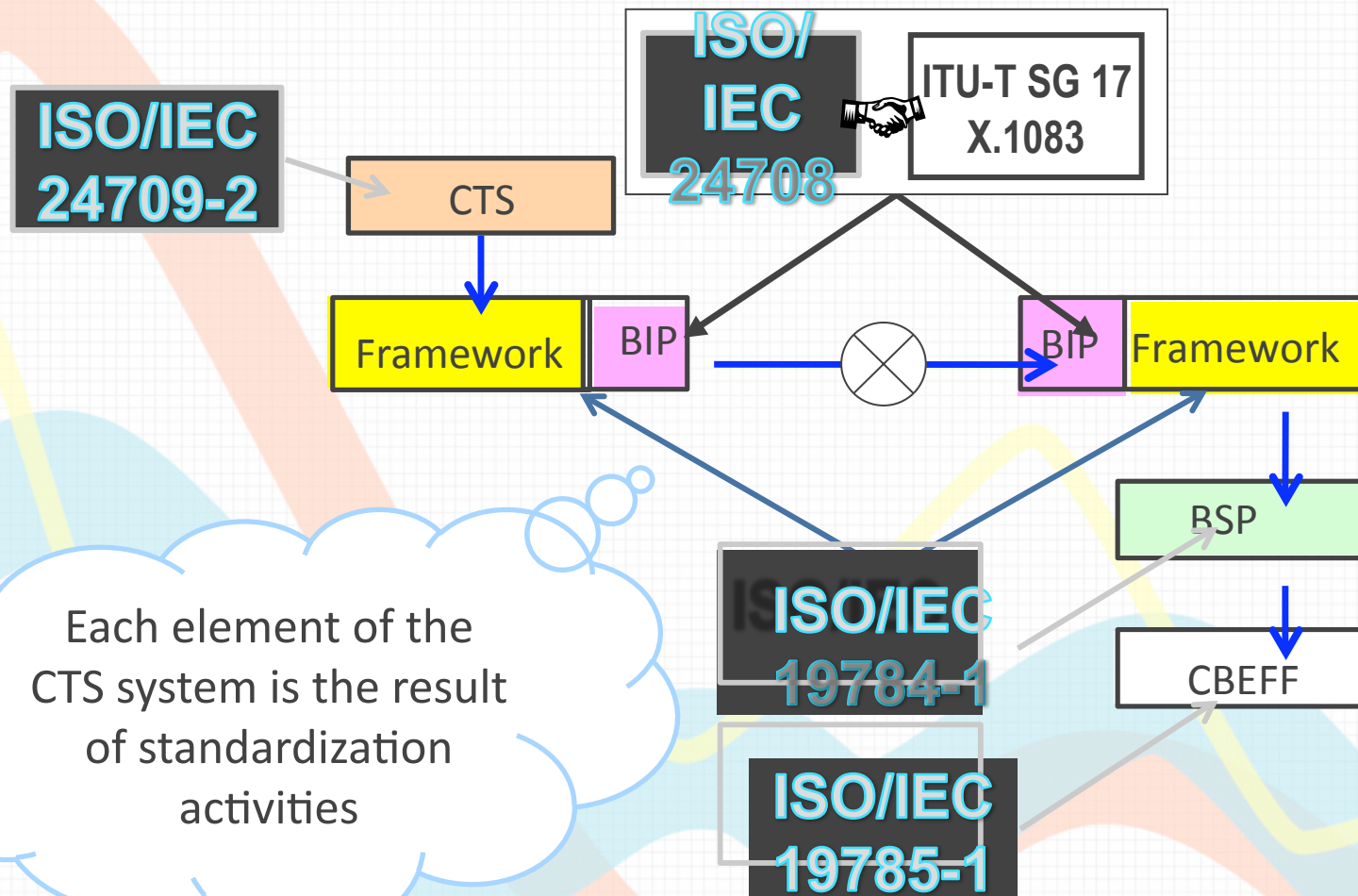

3. Expected Advantages (7/7)

(3) Showcase of standardization achievements (2/2)

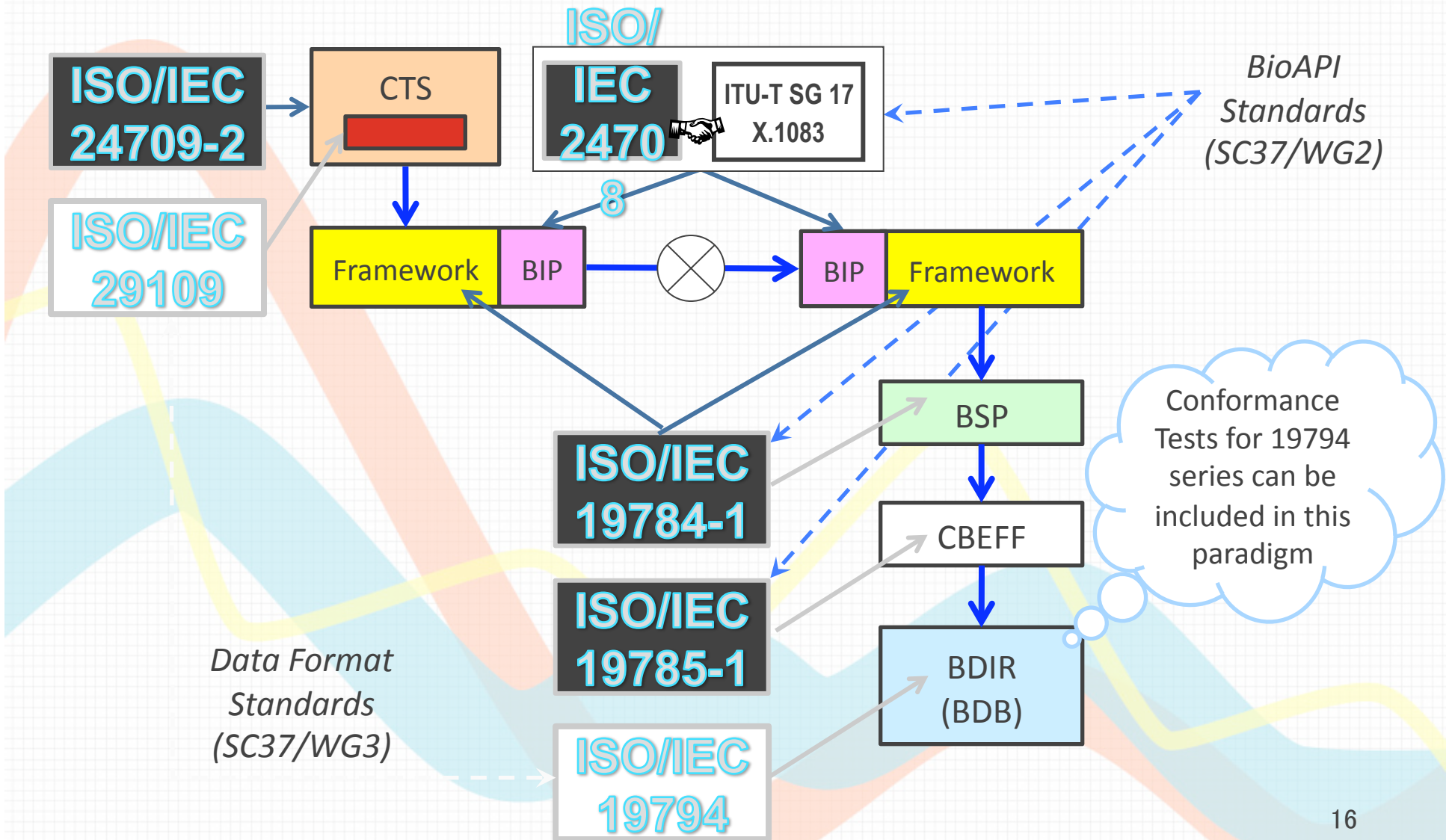

4. Grand Design for new CTS

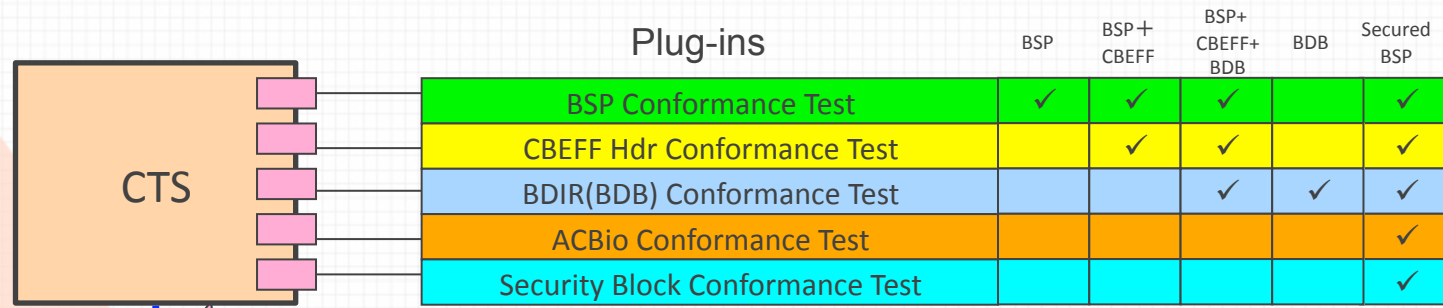

| Plug-ins | BSP | BSP+ CBEFF | BSP+ CBEFF+ BDB | BDB | Secured BSP |
|---------------------------------|-----|------------|-----------------|-----|-------------|
| BSP Conformance Test | ✓ | ✓ | ✓ | | ✓ |
| CBEFF Hdr Conformance Test | | ✓ | ✓ | | ✓ |
| BDIR(BDB) Conformance Test | | | ✓ | ✓ | ✓ |
| ACBio Conformance Test | | | | | ✓ |
| Security Block Conformance Test | | | | | ✓ |

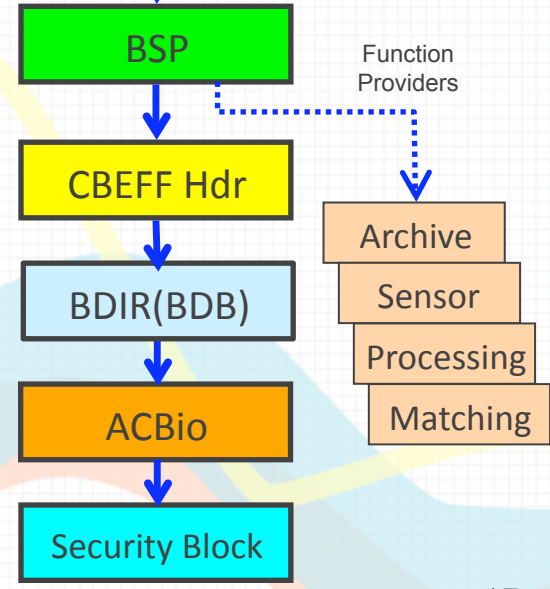
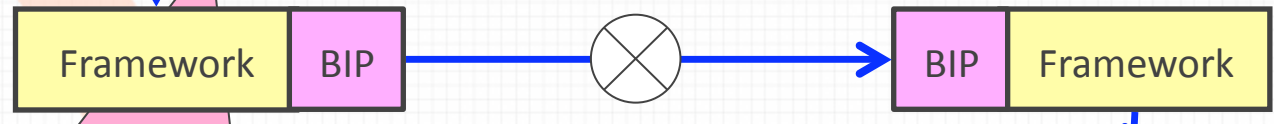

- Features of new CTS
1. Multiple-Platform Support
 2. Remote Product Certification
 3. All the standards under BSP can be applied
 4. Showcase of standardization achievements

5. Future Actions

- Action 1: Lists up major issues of the new CTS
 - (1) Clarification of the necessary features for Remote Product Certification
 - (2) Validation of the remote environment
 - (3) Clarification of restrictions caused by the existence of Framework and BIP
 - (4) Devising efficient testing scenarios to reduce the extra time needed by the network
- Action 2: Begins the efforts for resolution of the issues through standardization activities

6. Summary

1. New methodologies for BioAPI Conformance Testing

- (1) Methodology #1: CTS coupled with BioAPI Framework
- (2) Methodology #2: Expansion with BIP

2. Advantages of the CTS with new methodologies

- (1) Multiple-Platform Support
- (2) Remote Product Certification
- (3) All the standards under BSP can be applied
- (4) Opportunities to showcase the achievements of standardization

} Grand Design
for CTS

3. Future Actions

- (1) Lists up major issues of new CTS
- (2) Makes a plan for resolution of the issues through standardization activities

Thank you very much
for your attention!

OKI

Appendix-1: Test Methods to confirm the reliabilities of Framework and BIP

Reliability of Framework and BIP can be tested by using the Conformance Testing for BioAPI Frameworks (ISO/IEC 24709-3)

Conformance Test for Framework

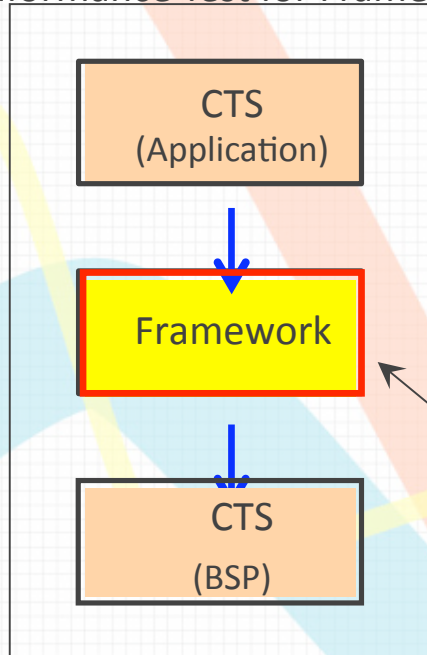

Test Object

Conducts the Conformance Test for Framework with BIP

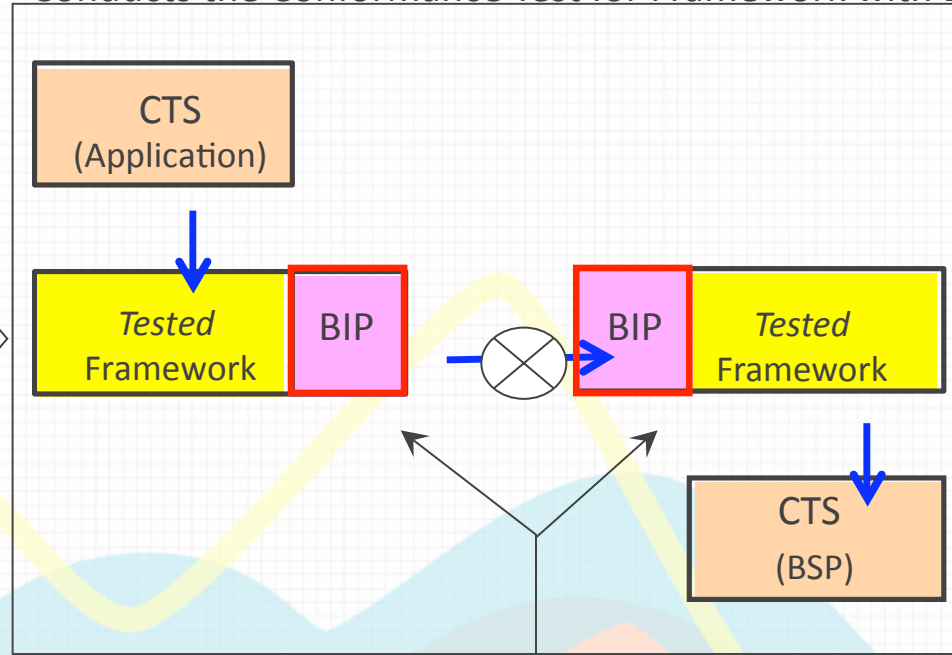

Test Object