



NIST

National Institute of
Standards and Technology
U.S. Department of Commerce

Report of the 99th National Conference on Weights and Measures

as adopted by the 99th
National Conference on Weights and Measures
2014

NIST Special
Publication **1193**

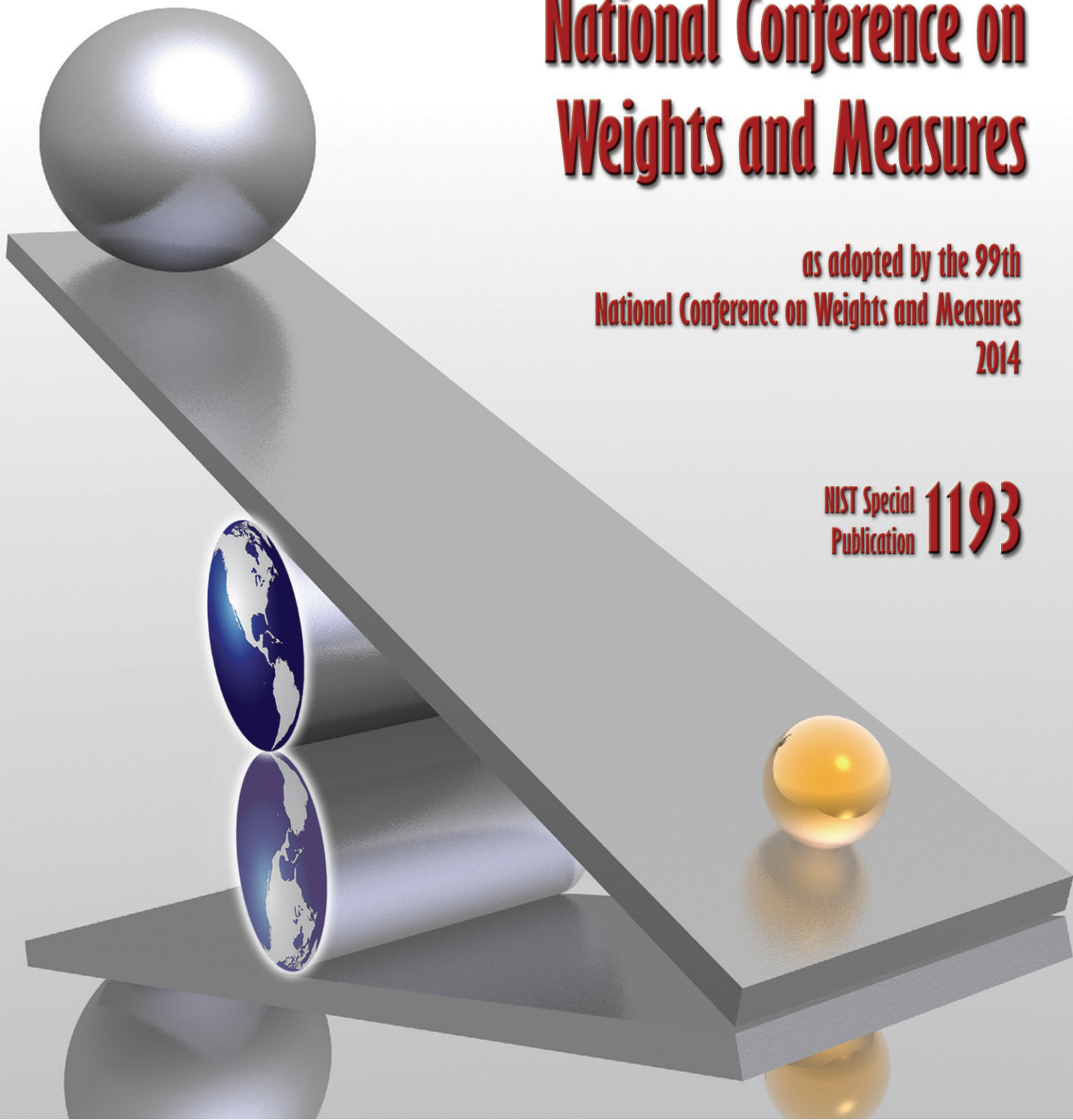

INSIDE FRONT COVER - BLANK

NIST Special Publication 1193

Report of the 99th National Conference on Weights and Measures



Detroit, Michigan – July 13 through 17, 2014
as adopted by the 99th National Conference on Weights and Measures 2014

Editors:

Tina Butcher
Linda Crown
Richard Harshman
David Sefcik
Lisa Warfield

Carol Hockett, Chief
Office of Weights and Measures
Physical Measurement Laboratory

<http://dx.doi.org/10.6028/NIST.SP.1193>

June 2015



U.S. Department of Commerce
Penny Pritzker, Secretary

National Institute of Standards and Technology
Willie May, Acting Under Secretary of Commerce for Standards and Technology and Director

The National Conference on Weights and Measures is supported by the National Institute of Standards and Technology and is attended by officials from various states, counties, and cities, as well as representatives from the U.S. Government, other nations, industry, and consumer organizations.

Certain commercial entities, equipment, or materials may be identified in this document in order to describe an experimental procedure or concept adequately. Such identification is not intended to imply recommendation or endorsement by the National Institute of Standards and Technology, nor is it intended to imply that the entities, materials, or equipment are necessarily the best available for the purpose.

Abstract

The 99th Annual Meeting of the National Conference on Weights and Measures (NCWM) was held July 13 -17, 2014, at the Westin Book Cadillac Detroit, Detroit, Michigan. The theme of the meeting was “Meeting Tomorrow’s Challenges Today!”

Reports by the NCWM Board of Directors, Standing Committees, and Special Purpose Committees constitute the major portion of this publication, along with the addresses delivered by Conference officials and other authorities from government and industry.

Special meetings included those of the Scale Manufacturers Association, Meter Manufacturers Association, Packaging and Labeling Subcommittee, Task Group on Printer Ink and Toner Cartridges, Fuels and Lubricants Subcommittee, Associate Membership Committee, Taximeter Technology Advancements, and Making Sense of Electronic Receipts.

Key words: laws and regulations; legal metrology; meters; scales; specifications and tolerances; training; type evaluation; uniform laws; weights and measures.

Note: The policy of the National Institute of Standards and Technology is to use metric units of measurement in all of its publications. In this publication, however, recommendations received by the NCWM technical committees have been printed as they were submitted, and, therefore, may contain references to U.S. Customary Units where such units are commonly used in industry practice. Opinions expressed in non-NIST papers are those of the authors and not necessarily those of the National Institute of Standards and Technology. Non-NIST speakers are solely responsible for the content and quality of their material.

National Institute of Standards and Technology Special Publication 11XX
Natl. Inst. Stand. Technol. Spec. Pub.1193, 630 pages (June 2015)
<http://dx.doi.org/10.6028/NIST.SP.1193>
CODEN: NSPUE2

National Conference on Weights and Measures

Annual Report of the 99th NCWM

Table of Contents

	Page
Abstract	ii
Past Chairman.....	v
Organizational Chart.....	ix
 General Session	
Honorary President’s Address – Dr. Willie May, NIST, Acting Director	GEN - 1
Chairman’s Address – John Gaccione, Westchester County, New York	GEN - 15
Chairman Elect’s Address – Ronald Hayes, Detroit, Michigan.....	GEN - 19
Awards and Recognition	
Contribution Award	GEN - 21
Distinguished Service Award Recipients.....	GEN - 21
Lifetime Achievement Award.....	GEN - 22
Attendance Recognitions	GEN - 22
 Standing Committee Reports	
Board of Directors (BOD).....	BOD-1
Appendix A. Report of the Activities of the International Organization of Legal Metrology (OIML) and Regional Legal Metrology Organizations	BOD - A1
Appendix B. Associate Membership Committee (AMC) Agenda and Draft Meeting Minutes.....	BOD - B1
Laws and Regulations Committee (L&R)	L&R - 1
Appendix A. Items 231-2, 232-3, 237-1, 237-2, 237-3, and 237-5: Background and Justification for NIST Handbook 130, Definition for “Diesel Gallon Equivalent (DGE)” of Natural Gas as a Vehicular Fuel.....	L&R - A1
Appendix B. Item 260-2: NIST Handbook 130, Handbook 133, Test Procedures – Packages Labeled by Volume, Section 3.12. Fresh Oysters Labeled by Volume	L&R - B1
Appendix C. Items 232-6 and 237-9: NIST Handbook 130, Uniform Regulation for the Method of Sale, Section 1. Definitions, Section 2. Standard Fuels Specifications, and Section 3. Classification and Method of Sale for Petroleum Items.....	L&R - C1
Specifications and Tolerances Committee (S&T)	S&T - 1
Appendix A. Item 320-2: NIST Handbook 44, UR.2.4. Foundations, Supports, and Clearance.....	S&T - A1
Appendix B. Item 320-3: NIST Handbook 44, Draft Tentative Code Applicable to Weigh-In-Motion Systems Used for Vehicle Enforcement Screening and proposed definitions to be added to NIST Handbook 44, Appendix D to support the Weigh-In-Motion Systems used for Vehicle Enforcement Screening – Draft Code	S&T - B1

Appendix C.	Item 330-4: NIST Handbook 44, N.4.2.5. Determination of Error on Wholesale Devices with Multiple Flow Rates and Calibration Factors	S&T - C1
Appendix D.	Item 331-1: NIST Handbook 44, N.4.2.1. Determination of Error on Vehicle-Tank Meters with Multiple Flow Rates and Calibration Factors	S&T - D1
Appendix E.	Items 337-1, 337-2, 337-3, 337-4, and 337-5: NIST Handbook 44, Background and Justification for NIST Handbook 44 Definition of “Diesel Gallon Equivalent (DGE)” of Natural Gas as a Vehicular Fuel	S&T - E1
Appendix F.	Item 358-1: NIST Handbook 44, Measurement of Bulk Material in Open-Top Truck and Trailer Units, Load Scanner Metrology, Test Methods and Suitability for Use by Loadscan Ltd.	S&T - F1
Appendix G.	Item 358-1: NIST Handbook 44, Load Volume Scanner – Proposals for Integration into Handbook 44	S&T - G1
Appendix H.	Item 360-3: NIST Handbook 44, Draft Code Requirements for Electric Vehicle Fueling and Submetering.....	S&T - H1
Professional Development Committee (PDC)		PDC - 1
Appendix A.	Professional Certification Program Curriculum Work Plan.....	PDC - A1
Appendix B.	History of Professional Certification Program.....	PDC - B1
Appendix C.	History of Instructor Improvement	PDC - C1
Appendix D.	Training Manual	PDC - D1
National Type Evaluation Program Committee (NTEP)		NTEP - 1
Appendix A.	NTEP Statistics Report	NTEP - A1
Appendix B.	Belt-Conveyor Scale Meeting Summary	NTEP - B1
Appendix C.	Grain Analyzer Sector Meeting Summary	NTEP - C1
Appendix D.	Measuring Sector Meeting Summary	NTEP - D1
Appendix E.	Software Sector Meeting Summary	NTEP - E1
Appendix F.	Weighing Sector Meeting Summary	NTEP - F1
Nominating Committee		NOM - 1
Attendees		ATTEND - 1

Past Chairmen of the Conference

Conference	Year	Location	Chairman
1 st	1905	Washington, D.C.	Dr. S. W. Stratton, Bureau of Standards
2 nd	1906	Washington, D.C.	Dr. S. W. Stratton, Bureau of Standards
3 rd	1907	Washington, D.C.	Dr. S. W. Stratton, Bureau of Standards
4 th	1908	Washington, D.C.	Dr. S. W. Stratton, Bureau of Standards
	1909	Conference Not Held	
5 th	1910	Washington, D.C.	Dr. S. W. Stratton, Bureau of Standards
6 th	1911	Washington, D.C.	Dr. S. W. Stratton, Bureau of Standards
7 th	1912	Washington, D.C.	Dr. S. W. Stratton, Bureau of Standards
8 th	1913	Washington, D.C.	Dr. S. W. Stratton, Bureau of Standards
9 th	1914	Washington, D.C.	Dr. S. W. Stratton, Bureau of Standards
10 th	1915	Washington, D.C.	Dr. S. W. Stratton, Bureau of Standards
11 th	1916	Washington, D.C.	Dr. S. W. Stratton, Bureau of Standards
	1917	Conference Not Held	
	1918	Conference Not Held	
12 th	1920	Washington, D.C.	Dr. S. W. Stratton, Bureau of Standards
13 th	1921	Washington, D.C.	Dr. S. W. Stratton, Bureau of Standards
14 th	1922	Washington, D.C.	Dr. S. W. Stratton, Bureau of Standards
15 th	1923	Washington, D.C.	Dr. George Burgess, Bureau of Standards
16 th	1924	Washington, D.C.	Dr. George Burgess, Bureau of Standards
17 th	1925	Washington, D.C.	Dr. George Burgess, Bureau of Standards
18 th	1926	Washington, D.C.	Dr. George Burgess, Bureau of Standards
19 th	1927	Washington, D.C.	Dr. George Burgess, Bureau of Standards
20 th	1928	Washington, D.C.	Dr. George Burgess, Bureau of Standards
21 st	1928	Washington, D.C.	Dr. George Burgess, Bureau of Standards
22 nd	1929	Washington, D.C.	Dr. George Burgess, Bureau of Standards
23 rd	1930	Washington, D.C.	Dr. George Burgess, Bureau of Standards
24 th	1931	Washington, D.C.	Dr. George Burgess, Bureau of Standards
	1932	Conference Not Held	
	1933	Conference Not Held	
	1934	Conference Not Held	
25 th	1935	Washington, D.C.	Dr. Lyman Briggs, National Bureau of Standards
26 th	1936	Washington, D.C.	Dr. Lyman Briggs, National Bureau of Standards
27 th	1937	Washington, D.C.	Dr. Lyman Briggs, National Bureau of Standards
28 th	1938	Washington, D.C.	Dr. Lyman Briggs, National Bureau of Standards

Conference	Year	Location	Chairman
29 th	1939	Washington, D.C.	Dr. Lyman Briggs, National Bureau of Standards
30 th	1940	Washington, D.C.	Dr. Lyman Briggs, National Bureau of Standards
31 st	1941	Washington, D.C.	Dr. Lyman Briggs, National Bureau of Standards
	1942	Conference Not Held	
	1943	Conference Not Held	
	1944	Conference Not Held	
	1945	Conference Not Held	
32 nd	1946	Washington, D.C.	Dr. E. U. Condon, National Bureau of Standards
33 rd	1947	Washington, D.C.	Dr. E. U. Condon, National Bureau of Standards
	1948	Conference Not Held	
34 th	1949	Washington, D.C.	Dr. E. U. Condon, National Bureau of Standards
35 th	1950	Washington, D.C.	Dr. E. U. Condon, National Bureau of Standards
36 th	1951	Washington, D.C.	Dr. E. U. Condon, National Bureau of Standards
37 th	1952	Washington, D.C.	Dr. E. U. Condon, National Bureau of Standards
38 th	1953	Washington, D.C.	Dr. E. U. Condon, National Bureau of Standards
39 th	1954	Washington, D.C.	Dr. E. U. Condon, National Bureau of Standards
40 th	1955	Washington, D.C.	Dr. E. U. Condon, National Bureau of Standards
41 st	1956	Washington, D.C.	Dr. A. V. Astin, National Bureau of Standards
42 nd	1957	Washington, D.C.	Dr. A. V. Astin, National Bureau of Standards
43 rd	1958	Washington, D.C.	J. P. McBride, MA
44 th	1959	Washington, D.C.	C. M. Fuller, CA
45 th	1960	Washington, D.C.	H. E. Crawford, FL
46 th	1961	Washington, D.C.	R. E. Meek, IN
47 th	1962	Washington, D.C.	R. Williams, NY
48 th	1963	Washington, D.C.	C. H. Stender, SC
49 th	1964	Washington, D.C.	D. M. Turnbull, WA
50 th	1965	Washington, D.C.	V. D. Campbell, OH
51 st	1966	Denver, CO	J. F. True, KS
52 nd	1967	Washington, D.C.	J. E. Bowen, MA
53 rd	1968	Washington, D.C.	C. C. Morgan, IN
54 th	1969	Washington, D.C.	S. H. Christie, NJ
55 th	1970	Salt Lake City, UT	R. W. Searles, OH
56 th	1971	Washington, D.C.	M. Jennings, TN
57 th	1972	Washington, D.C.	E. H. Black, CA
58 th	1973	Minneapolis, MN	G. Johnson, KY
59 th	1974	Washington, D.C.	J. Lewis, WA
60 th	1975	San Diego, CA	S. Andrews, FL

Conference	Year	Location	Chairman
61 st	1976	Washington, D.C.	R. Thompson, MD
62 nd	1977	Dallas, TX	E. Prideaux, CO
63 rd	1978	Washington, D.C.	J. Lyles, WA
64 th	1979	Portland, OR	K. Simila, OR
65 th	1980	Washington, D.C.	C. Vincent, TX
66 th	1981	St. Louis, MO	E. Stadolnik, MA
67 th	1982	Atlanta, GA	E. Heffron, MI
68 th	1983	Sacramento, CA	C. Greene, NM
69 th	1984	Boston, MA	S. Hindsman, AR
70 th	1985	Washington, D.C.	E. Delfino, CA
71 st	1986	Albuquerque, NM	G. Mattimoe, HI
72 nd	1987	Little Rock, AR	F. Nagele, MI
73 rd	1988	Grand Rapids, MI	D. Guensler, CA
74 th	1989	Seattle, WA	J. Bartfai, NY
75 th	1990	Washington, D.C.	F. Gerck, NM
76 th	1991	Philadelphia, PA	N. D. Smith, NC
77 th	1992	Nashville, TN	S. Colbrook, IL
78 th	1993	Kansas City, MO	A. Nelson, CT
79 th	1994	San Diego, CA	T. Geiler, MA
80 th	1995	Portland, ME	J. Truex, OH
81 st	1996	New Orleans, LA	C. Gardner, NY
82 nd	1997	Chicago, IL	B. Bloch, CA
83 rd	1998	Portland, OR	S. Malone, NE
84 th	1999	Burlington, VT	A. Thompson, AK
85 th	2000	Richmond, VA	W. Diggs, VA
86 th	2001	Washington, D.C.	L. Straub, MD
87 th	2002	Cincinnati, OH	R. Murdock, NC
88 th	2003	Sparks, NV	R. Andersen, NY
89 th	2004	Pittsburgh, PA	D. Ehrhart, AZ
90 th	2005	Orlando, FL	W. Diggs, VA
91 st	2006	Chicago, IL	D. Onwiler, NE
92 nd	2007	Salt Lake City, UT	M. Cleary, CA
93 rd	2008	Burlington, VT	J. Cardin, WI
94 th	2009	San Antonio, TX	J. Kane, MT
95 th	2010	St. Paul, MN	R. Jennings, TN
96 th	2011	Missoula, MT	T. Tyson, KS
97 th	2012	Portland, ME	K. Floren, CA

Past Chairmen – 2014 Final Report

Conference	Year	Location	Chairman
98 th	2013	Louisville, KY	S. Benjamin, NC
99 th	2014	Detroit, MI	J. Gaccione, Westchester County, NY

2013 – 2014 Organizational Chart



NCWM Board of Directors			
OFFICE	NAME	AFFILIATION	TERM ENDS
Chairman	John Gaccione	Westchester County, New York	2014
Chairman-Elect	Ron Hayes	Missouri	2014
NTEP Committee Chair	Stephen Benjamin	North Carolina	2014
Treasurer	Mark Coyne	City of Brockton, Massachusetts	2014
Active Membership - Western	Jerry Buendel	Washington	2017
Active Membership - Central	Craig VanBuren	Michigan	2015
Active Membership - Southern	Kenneth Ramsburg	Maryland	2018
Active Membership - Northeastern	James Cassidy	City of Cambridge, Massachusetts	2014
At-Large	Chuck Corr	Archer Daniels Midland Company	2018
At-Large	Steve Giguere	Maine	2016
Associate Membership	Christopher Guay	Procter and Gamble, Co.	2016
Honorary NCWM President	Dr. Patrick D. Gallagher	NIST Director	NA
Executive Secretary	Carol Hockett	NIST, Office of Weights and Measures	NA
Executive Director	Don Onwiler	NCWM	NA
Board of Directors Advisor	Gilles Vinet	Measurement Canada	NA
NTEP Administrator	Jim Truex	NCWM	NA
National Type Evaluation Program Committee (NTEP)			
OFFICE	NAME	AFFILIATION	TERM ENDS
Committee Chair	Stephen Benjamin	North Carolina	2014
Member	John Gaccione	Westchester County, New York	2014
Member	James Cassidy	Massachusetts	2014
Member	Ronald Hayes	Missouri	2015
Member	Jerry Buendel	Washington	2017
NTEP Administrator	Jim Truex	NCWM Headquarters	NA
Finance Committee			
OFFICE	NAME	AFFILIATION	TERM ENDS
Committee Chair	Ron Hayes	Missouri	2014
Chair-Elect	Jerry Buendel	Washington	2014
Member	Mark Coyne	City of Brockton, Massachusetts	2014
Member	Christopher Guay	Procter and Gamble, Co.	2016
Executive Director	Don Onwiler	NCWM Headquarters	NA

Organizational Chart – 2014 Final Report

Laws and Regulations Committee (L&R)			
OFFICE	NAME	AFFILIATION	TERM ENDS
Committee Chair	Raymond Johnson	New Mexico	2014
Member	Tim Lloyd	Montana	2015
Member	Richard Lewis	Georgia	2016
Member	Louis Sakin	Towns of Hopkinton/Northbridge, Massachusetts	2017
Member	John Albert	Missouri	2018
Associate Membership Representative	Steve Grabski	Wal-Mart	2018
Canadian Technical Advisor	Lance Robertson	Measurement Canada	NA
NIST Technical Advisor	David Sefcik	NIST, Office of Weights and Measures	NA
NIST Technical Advisor	Lisa Warfield	NIST, Office of Weights and Measures	NA
Professional Development Committee (PDC)			
OFFICE	NAME	AFFILIATION	TERM ENDS
Committee Chair	Dale Saunders	Virginia	2014
Member	Cheryl Ayer	New Hampshire	2015
Member	Kristin Macey	California	2016
Member	Stacy Carlsen	Marin County, California	2017
Member	Julie Quinn	Minnesota	2018
Associate Membership Representative	Richard Shipman	Rice Lake Weighing Systems	2018
Safety Liaison	TBD		NA
NIST Technical Advisor	TBD		NA
Certification Coordinator	Ross Andersen	Retired	NA
Specifications and Tolerances Committee (S&T)			
OFFICE	NAME	AFFILIATION	TERM ENDS
Committee Chair	Brett Gurney	Utah	2015
Member	Mahesh Albuquerque	Colorado	2016
Member	Jane Zulkiewicz	Town of Barnstable, Massachusetts	2017
Member	Matthew Curran	Florida	2018
Member	Ivan Hankins	Iowa	2014
Canadian Technical Advisor	Luciano Burtini	Measurement Canada	NA
NIST Technical Advisor	Tina Butcher	NIST, Office of Weights and Measures	NA
NIST Technical Advisor	Rick Harshman	NIST, Office of Weights and Measures	NA

Nominating Committee			
OFFICE	NAME	AFFILIATION	TERM ENDS
Committee Chair	Stephen Benjamin	North Carolina	2014
Member	Tim Tyson	Kansas	2014
Member	Charles Carroll	Massachusetts	2014
Member	Joe Gomez	New Mexico	2014
Member	Tim Chesser	Arkansas	2014
Member	Frank Greene	Connecticut	2014
Member	Angela Godwin	Ventura County, California	2014
Credentials Committee			
OFFICE	NAME	AFFILIATION	TERM ENDS
Committee Chair	Craig VanBuren	Michigan	2014
Member	Jerry Butler	North Carolina	2015
Member	Fran Elson-Houston	Ohio	2016
Coordinator	Darrell Flocken	NCWM	2014
Appointive Officials			
OFFICE	NAME	AFFILIATION	TERM ENDS
Chaplain	Stephen Langford	Cardinal Scale Manufacturing, Co.	2014
Parliamentarian	Louis Straub	Fairbanks Scale, Inc.	2014
Presiding Officer	Jack Walsh	Town of Wellesley	2014
Presiding Officer	Jerry Butler	North Carolina	2014
Presiding Officer	Marco Mares	San Diego County, California	2014
Presiding Officer	Scott Ferguson	Michigan	2014
Sergeants-at-Arms	Jim Brown	Michigan	2014
Sergeants-at-Arms	Chris Chamberlain	Michigan	2014
Sergeants-at-Arms	Dave Crowley	Michigan	2014
Sergeants-at-Arms	Joe Daugherty	Michigan	2014
Sergeants-at-Arms	Jason DeChene	Michigan	2014
Sergeants-at-Arms	Scott Ferguson	Michigan	2014
Sergeants-at-Arms	Steve Galvan	Michigan	2014
Sergeants-at-Arms	Samantha Hartman	Michigan	2014
Sergeants-at-Arms	Justin Houghton	Michigan	2014
Sergeants-at-Arms	Sean McGuire	Michigan	2014
Sergeants-at-Arms	Jim Oswald	Michigan	2014
Sergeants-at-Arms	John Willer	Michigan	2014

Organizational Chart – 2014 Final Report

Associate Membership Committee			
OFFICE	NAME	AFFILIATION	TERM ENDS
Chair	Paul Lewis, Sr.	Rice Lake Weighing Systems, Inc.	2014
Vice Chair	Bill Callaway	Crompco	2014
Secretary/Treasurer	David Calix	NCR Corporation	2014
Member	Paul Lewis, Sr.	Rice Lake Weighing Systems, Inc.	2014
Member	Steven Grabski	Walmart	2015
Member	Christopher Guay	Procter and Gamble, Co.	2015
Member	Thomas McGee	PMP Corporation	2015
Member	Rob Underwood	Petroleum Marketers Association of America	2015
Member	Pete O'Bryan	Foster Farms	2016
Member	David Calix	NCR Corporation	2018
Member	Bill Callaway	Crompco	2018
Member	Robert Murnane, Jr.	Seraphin Test Measure	2018
Packaging and Labeling Subcommittee			
OFFICE	NAME	AFFILIATION	
Chair	Christopher Guay	Procter and Gamble, Co.	
NIST Technical Advisor	David Sefcik	NIST, Office of Weights and Measures	
Public Sector – Central	Nicholas Owens	Stark County Weights and Measures	
Public Sector - Northeastern	Frank Greene	Connecticut	
Public Sector - Southern	Bill Tedder	North Carolina	
Public Sector - Western	Angela Godwin	County of Ventura	
Private Sector Member	Ann Boeckman	Kraft Food Group, Inc.	
Private Sector Member	Krister Hard af Segerstad	IKEA North America Services, LLC	
Private Sector Member	Zina Juroch	Pier 1 Imports	
Private Sector Member	Pete O'Bryan	Foster Farms	
Private Sector Member	Stratt Pinagel	Walmart Stores, Inc.	

Fuels and Lubricants Subcommittee		
OFFICE	NAME	AFFILIATION
Chair	Matthew Curran	Florida
Vice-Chair	Ron Hayes	Missouri
Vice-Chair	Randy Jennings	Tennessee
Secretary	Kristin Moore	Renewable Fuels Association
Vice-Secretary	Rebecca Richardson	MARC IV Consulting
NIST Technical Advisor	Kenneth Butcher	NIST, Office of Weights and Measures
NIST Technical Advisor	David Sefcik	NIST, Office of Weights and Measures
NIST Technical Advisor	Lisa Warfield	NIST, Office of Weights and Measures
Public Sector Member	Mahesh Albuquerque	Colorado
Public Sector Member	Stephen Benjamin	North Carolina
Public Sector Member	Steven Harrington	Oregon
Public Sector Member	Kristin Macey	California
Public Sector Member	Timothy White	Michigan
Public Sector Member	Bill Striejewske	Nevada
Private Sector Member	Chuck Corr	Archer Daniels Midland Company
Private Sector Member	Kevin Ferrick	API
Private Sector Member	K.W. Gardner	ExxonMobil Corporation
Private Sector Member	Bill Geubelle	Phillips 66
Private Sector Member	Philip Guillemette	Flint Hills Resources, LP
Private Sector Member	John Harkins	Sunoco, Inc.
Private Sector Member	Marilyn Herman	Herman and Associates
Private Sector Member	Jerome Horn	Chevron Global Downstream, LLC
Private Sector Member	Joanna Johnson	Automotive Oil Exchange Association
Private Sector Member	Patrick Kelly	API
Private Sector Member	David A. Kovach	BP Products
Private Sector Member	Roger Leisenring, Jr.	KiOR
Private Sector Member	Russ Lewis	Marathon Petroleum, LLC
Private Sector Member	James McGetrick	BP Products
Private Sector Member	Robert Nelson	Shell Oil Products
Private Sector Member	Manuch Nikanjam	Chevron Global Downstream, LLC
Private Sector Member	Keith Penn	Colonial Pipeline Company
Private Sector Member	Derek Regal	Tesoro Companies, Inc.
Private Sector Member	Prentiss Searles	American Petroleum Institute
Private Sector Member	William Studzinski	General Motors
Private Sector Member	Rob Underwood	Petroleum Marketers Association of America
Private Sector Member	Curtis Williams	CP Williams Energy Consulting, LLC
Private Sector Member	William Woebkenberg	Mercedes-Benz Research and Development NA

Organizational Chart – 2014 Final Report

Natural Gas Steering Committee		
OFFICE	NAME	AFFILIATION
Chair	Maresh Albuquerque (S&T)	Colorado
Vice-Chair	Raymond Johnson	New Mexico
NIST Technical Advisor	Juana Williams	NIST Office of Weights and Measures
General Counsel	Jeffrey L. Clarke	NGV America
Public Sector – Central	Ronald Hayes	Missouri
Public Sector - Northeast	Ethan Bogren	Westchester County, New York
Public Sector – Southern	Matthew Curran	Florida
Private Sector Member	Brett Barry	Clean Energy
Private Sector Member	Josh Brown	NorthStar, Inc.
Private Sector Member	Scott Hartman	Shell
Private Sector Member	Douglas Horne	Clean Vehicle Education Foundation
Private Sector Member	David Jaskolski	Pivotal LNG
Private Sector Member	Gordon Johnson	Gilbarco, Inc.
Private Sector Member	Dmitri Karimov	Liquid Controls
Private Sector Member	Elisabeth Treseder	American Petroleum Institute
Promotional Tool Kit Task Group		
OFFICE	NAME	AFFILIATION
Chair	Stephen Benjamin	North Carolina
Public Sector Member	Kurt Floren	Los Angeles County
Public Sector Member	Jerry Buendel	Washington
Private Sector Member	Henry Oppermann	Weights and Measures Consulting
Private Sector Member	John Hughes	Rice Lake Weighing Systems
Training Manual Task Group		
OFFICE	NAME	AFFILIATION
Chair	Michael Cleary	Retired: California
Public Sector Member	Craig Harris	Ohio
Public Sector Member	Josh Nelson	Oregon
Public Sector Member	Julie Quinn	Minnesota
Public Sector Member	Deborah Rader	Arizona
Public Sector Member	Scott Simmons	Colorado

Organometallics Task Group		
OFFICE	NAME	AFFILIATION
Chair	Randy Jennings	Tennessee
Public Sector Member	Ron Hayes	Missouri
Private Sector Member	John Cabaniss	Global Automakers
Private Sector Member	Marilyn Herman	Herman and Associates
Private Sector Member	Jeff Jetter	Honda R&D Americas, Inc.
Private Sector Member	Russ Lewis	Marathon Petroleum
Private Sector Member	James McGetrick	BP
Private Sector Member	Mike Meffert	Afton Chemical
Private Sector Member	Kristy Moore	Renewable Fuels Foundation
Private Sector Member	Derek Regal	Tesoro Chemical
Private Sector Member	Charles Richardson	Ford Motor Company
Private Sector Member	Jenny Sigelko	Volkswagen Group of America
Private Sector Member	Val Ughetta	Alliance of Automobile Manufacturers
Task Group on Retail Motor Fuel Dispenser Price Posting and Computer Capability		
OFFICE	NAME	AFFILIATION
Chair	Fran Elson-Houston	Ohio
NIST Technical Advisor	Juana Williams	NIST, Office of Weights and Measures
Public Sector Member	Shelly Miller	Wisconsin
Public Sector Member	Ken Ramsburg	Maryland
Public Sector Member	Jerry Buendel	Washington State Department of Agriculture
Private Sector Member	Rex Brown	Petroleum Equipment Institute
Private Sector Member	John Eichberger	National Association of Convenience Stores
Private Sector Member	Gordon Johnson	Gilbarco, Inc.
Private Sector Member	Phil Katselnik	Dresser Wayne
Private Sector Member	Mike Roach	VeriFone
Private Sector Member	Richard Suiter	Richard Suiter Consulting
Private Sector Member	Richard Tucker	RL Tucker Consulting
Private Sector Member	Rob Underwood	Petroleum Marketers Association of America
Multiple Dimensions Measuring Device Work Group		
OFFICE	NAME	AFFILIATION
Chair	Robert Kennington	Quantronix, Inc.
NIST Technical Advisor	TBD	NIST, Office of Weights and Measures
Public Sector Member	Fran Elson-Houston	Ohio
Public Sector Member	Luciano Burtini	Measurement Canada
Public Sector Member	Justin Rae	Measurement Canada
Private Sector Member	Scott Wigginton	United Parcel Service

Organizational Chart – 2014 Final Report

NTEP Belt-Conveyor Sector		
OFFICE	NAME	AFFILIATION
Chair	Bill Ripka	Thermo Fisher Scientific
Technical Advisor	John Barton	NIST, Office of Weights and Measures
NTEP Administrator	Jim Truex	NCWM Headquarters
Public Sector Member	Tina Butcher	NIST, Office of Weights and Measures
Public Sector Member	Ken Jones	California
Private Sector Member	Rafael Jimenez	Association of American Railroads Transportation Technology Center, Inc.
Private Sector Member	Lars Marmsater	Merrick Industries, Inc.
Private Sector Member	Peter Sirrico	Thayer Scale / Hyer Industries
Private Sector Member	Thomas Vormittag	Nevada
NTEP Grain Analyzer Sector		
OFFICE	NAME	AFFILIATION
Chair	Cassie Eigenmann	DICKEY-john Corporation
Technical Advisor	G. Diane Lee	NIST, Office of Weights and Measures
NTEP Administrator	Jim Truex	NCWM Headquarters
Public Sector Member	Tina Butcher	NIST, Office of Weights and Measures
Public Sector Member	Randy Burns	Arkansas
Public Sector Member	Karl Cunningham	Illinois
Public Sector Member	Thomas Hughes	Missouri
Public Sector Member	Ivan Hankins	Iowa
Public Sector Member	Cathleen Brenner	USDA, GIPSA Technical Services Division
Private Sector Member	Jeffrey Adkisson	Grain and Feed Association of Illinois
Private Sector Member	James Bair	North American Miller's Association
Private Sector Member	Rachel Beiswenger	TSI Incorporated
Private Sector Member	Martin Clements	The Steinlite Corporation
Private Sector Member	Andrew Gell	Foss North America
Private Sector Member	Charles Hurburgh, Jr.	Iowa State University
Private Sector Member	Jess McCluer	National Grain and Feed Association
Private Sector Member	Thomas Runyon	Seedburo Equipment Co.

NTEP Measuring Sector		
OFFICE	NAME	AFFILIATION
Chair	Michael Keilty	Endress + Hauser Flowtec AG, USA
Technical Advisor	TBD	NIST, Office of Weights and Measures
NTEP Administrator	Jim Truex	NCWM Headquarters
Public Sector Member	Dennis Beattie	Measurement Canada
Public Sector Member	Tina Butcher	NIST, Office of Weights and Measures
Public Sector Member	Jerry Butler	North Carolina
Public Sector Member	John Roach	California
Private Sector Member	Steve Bar	Bennett Pump Company
Private Sector Member	William Cooper	Tuthill Transfer Systems
Private Sector Member	Constantine Cotsoradis	Flint Hills Resources
Private Sector Member	Paul Glowacki	Murray Equipment, Inc.
Private Sector Member	Gordon Johnson	Gilbarco, Inc.
Private Sector Member	Dmitri Karimov	Liquid Controls
Private Sector Member	Yefim Katselnik	Dresser Wayne
Private Sector Member	Douglas Long	RDM Industrial Electronics
Private Sector Member	Andrew MacAllister	Daniel Measurement and Control
Private Sector Member	Wade Mattar	Invensys / Foxboro
Private Sector Member	Richard Miller	FMC Technologies Measurement Solutions, Inc.
Private Sector Member	Donald Mundorff	Badger Meter Scottsdale
Private Sector Member	Andre Noel	Neptune Technology Group, Inc.
Private Sector Member	Henry Oppermann	Weights & Measures Consulting, LLC
Private Sector Member	Johnny Parrish	Brodie International
Private Sector Member	Dan Peterson	Yokogawa Corporation of America
Private Sector Member	Richard Tucker	RL Tucker Consulting, LLC

Organizational Chart – 2014 Final Report

NTEP Software Sector		
OFFICE	NAME	AFFILIATION
Chair	James Pettinato	FMC Technologies Measurement Solutions, Inc.
Secretary	Teri Gulke	Liquid Controls, LLC
Technical Advisor	Doug Bliss	Mettler-Toledo, Inc.
NTEP Administrator	Jim Truex	NCWM Headquarters
Public Sector Member	Dennis Beattie	Measurement Canada
Public Sector Member	Michael Frailer	Maryland
Public Sector Member	Ken Jones	California
Public Sector Member	Joe Morrison	Ohio
Public Sector Member	Eric Morabito	New York
Public Sector Member	Edward Payne	Maryland
Public Sector Member	John Roach	California
Public Sector Member	Zacharias Tripoulas	Maryland
Public Sector Member	Ambler Thompson	NIST, Office of Weights and Measures
Private Sector Member	Mary Abens	Emerson Process Management
Private Sector Member	John Atwood	Tyson Foods
Private Sector Member	Gary Benjamin	NCR Corporation
Private Sector Member	Kevin Detert	Avery Weigh-Tronix
Private Sector Member	Cassie Eigenmann	DICKEY-john Corporation
Private Sector Member	Andre Elle	Endress + Hauser Flowtec AG
Private Sector Member	Andrew Gell	Foss North America
Private Sector Member	Keith Harper	Gencor Industries, Inc.
Private Sector Member	Tony Herrin	Cardinal Scale Manufacturing Co.
Private Sector Member	Paul A. Lewis, Sr.	Rice Lake Weighing Systems, Inc.
Private Sector Member	Rick Lydon	Sick, Inc.
Private Sector Member	Richard Miller	FMC Technologies Measurement Solutions, Inc.
Private Sector Member	Christopher (Adam) Oldham	Gilbarco, Inc.
Private Sector Member	Mike Roach	VeriFone
Private Sector Member	Robin Sax	CompuWeigh Corporation
Private Sector Member	David Vande Berg	Vande Berg Scales
Private Sector Member	John Wind	Bizerba USA, Inc.
Private Sector Member	Kraig Wooddell	Hobart

NTEP Weighing Sector		
OFFICE	NAME	AFFILIATION
Chair	Rob Upright	Vishay Transducers
Technical Advisor	Rick Harshman	NIST, Office of Weights and Measures
NTEP Administrator	Jim Truex	NCWM
NTEP Specialist	Darrell Flocken	NCWM
Public Sector Member	L. Cary Ainsworth	USDA, GIPSA
Public Sector Member	Luciano Burtini	Measurement Canada
Public Sector Member	Tina Butcher	NIST, Office of Weights and Measures
Public Sector Member	Fran Elson-Houston	Ohio
Public Sector Member	Ken Jones	California
Public Sector Member	Edward Payne	Maryland
Public Sector Member	Bryon School	USDA, GIPSA, FGIS
Public Sector Member	Zacharias Tripoulas	Maryland
Public Sector Member	Tim Tyson	Kansas
Public Sector Member	Juana Williams	NIST, Office of Weights and Measures
Private Sector Member	Steven Beitzel	Systems Associates, Inc.
Private Sector Member	Greg Bredahl	Thermo Fisher Scientific
Private Sector Member	Neil Copley	Thurman Scale Co.
Private Sector Member	Hayden Cornish	Schenck Process
Private Sector Member	Mitchell Eyles	Flintec, Inc.
Private Sector Member	Robert Feezor	Scales Consulting and Testing
Private Sector Member	Scott Henry	Motorola Solutions, Inc.
Private Sector Member	Sam Jalahej	Totalcomp, Inc.
Private Sector Member	Rafael Jimenez	Association of American Railroads Transportation Technology Center, Inc.
Private Sector Member	Stephen Langford	Cardinal Scale Manufacturing, Co.
Private Sector Member	Paul A. Lewis, Sr.	Rice Lake Weighing Systems, Inc.
Private Sector Member	L. Edward Luthy	Schenck Process Transport N.A.
Private Sector Member	Nigel Mills	Hobart Corporation
Private Sector Member	Jamie San Pedro	Coti Global Sensors
Private Sector Member	Wayne Pugh	OCS Checkweighers, Inc.
Private Sector Member	Louis Straub	Fairbanks Scales, Inc.
Private Sector Member	Russell Vires	Mettler-Toledo, LLC
Private Sector Member	Jerry Wang	A&D Engineering, Inc.
Private Sector Member	Walter Young	Emery Winslow Scale Company

Organizational Chart – 2014 Final Report

Western Weights and Measures Association (WWMA) www.westernwma.org					
States	Alaska Arizona California	Colorado Hawaii Idaho	Montana Nevada New Mexico	Oregon Utah Washington	Wyoming
Contact	Brett Saum San Luis Obispo County Weights and Measures (CA)			(805) 781-5922 bsaum@co.slo.ca.us	
Annual Meeting					
Central Weights and Measures Association (CWMA) www.cwma.net					
States	Illinois Indiana Iowa	Kansas Michigan Minnesota	Missouri Nebraska North Dakota	Ohio South Dakota Wisconsin	
Contact	Sherry Turvey Kansas Department of Agriculture			(785) 862-2415 sherry.turvey@kda.ks.gov	
Annual Meeting					
Interim Meeting					
Southern Weights and Measures Association (SWMA) www.swma.org					
States	Alabama Arkansas Delaware District of Columbia Florida	Georgia Kentucky Louisiana Maryland Mississippi	North Carolina Oklahoma South Carolina Tennessee	Texas U.S. Virgin Islands Virginia West Virginia	
Contact	Stephen Benjamin North Carolina Department of Agriculture			(919) 733-3313 steve.benjamin@ncagr.gov	
Annual Meeting					
Northeastern Weights and Measures Association (NWMA) www.newma.us					
States	Connecticut Maine Massachusetts	New Hampshire New Jersey New York	Pennsylvania Puerto Rico Rhode Island	Vermont	
Contact	James Cassidy City of Cambridge Weights and Measures Department			(617) 349-6133 jcassidy@cambridgema.gov	
Annual Meeting					
Interim Meeting					

Honorary President's Address
National Institute of Standards and Technology
Detroit, Michigan
July 15, 2015
Dr. Willie E. May

Acting Under Secretary of Commerce for Standards and Technology and Acting Director

- Thanks Carol for that very gracious introduction.
- Good morning everyone.
 - I'd like to thank Chairman Gaccione and Don Onwiler of NCWM for again, inviting me to present the annual Honorary President's Address.
- It's great to be here in the Motor City.
 - Detroit has given this country so much considering the pioneering work that has been done here.
 - This city has, in many ways, laid the foundation for the United States as we know it today.
 - It kindled our love affair with the automobile and with the freedom it represents.
- **Detroit is known for its history of innovation.** It's where the assembly line was born, as well as the first paved road, the first traffic light, the first freeway, the first international tunnel, and most importantly, the first automatic coffeemaker.
- Some people think that Detroit's best days are behind it, but I have to disagree.
 - For a while, we were a nation that had stopped making things, but we've started to see that trend reverse, and I believe that this city can and will turn itself around.
 - While there is still a lot to be done to regain our momentum, automakers in this town have begun doing some very innovative things.
 - I'm really looking forward to seeing what the future holds.

About NIST

- NIST and Detroit actually have something in common. For one, we were both born about the same time.
- NIST was founded in 1901 to perform measurement research vital to industry and to provide a framework for the preservation and faithful dissemination of standard measurement units, which are vital to industrial and scientific progress and to commerce.
- Eight years later, 1909, the first Model T rolled off the line. Between 1920 and 1930, the number of cars registered in the United States leapt from 9 million to 26.5 million, and well over half of them were Model Ts and nearly all of them were built right here – in Detroit.

- Geologists at the time believed that the supply of oil would be gone in as little as 10 years, so some of NIST’s first research related to the automobile industry was concerned with improving fuel economy. We worked to improve ignition systems, carburetors, and lubricants, as well as the quality of the gasoline.
- Working with the U.S. Army, we published performance metrics for engines, fuels, and lubricating oils.
- We tested brakes, driver reaction times – and in the 1960s, NIST research was also integral to seat belt and car safety standards.
 - And we still today have a number of collaborations with and provide measurement services for the automotive industry.

NIST NOW and RESEARCH EXAMPLES

- Our new Center for Automotive Lightweighting is working to help the industry make vehicles that are much lighter in weight, but just as safe. We’re providing the data the industry needs to reliably manufacture vehicle components from lightweight substitutes, including aluminum alloys, high-strength steels, and polymer composites.
- A lighter automobile needs less fuel to move a given distance, whether that’s **gasoline, diesel, electricity, hydrogen, liquefied natural gas, or some hybrid approach,**
- Using less fuel means lower emissions and better air quality.
- While we love going for a drive, frankly most of the time we’re driving we’re really just trying to get home. And we’ve made some real innovations concerning energy efficient homes as well.

NET Zero Energy House

- We constructed and demonstrated the efficacy of a “net zero energy home” that looks just like any home in suburbia and yet generates as much energy as it needs. And our researchers did it with commercially available technologies and without sacrificing anything in terms of creature comforts or energy usage.
- NIST has also been active in our role as an organizer, bringing stakeholders to the table to solve common problems that would be difficult for them to solve on their own.

CYBERSECURITY FRAMEWORK AND FORENSICS

- This past February, NIST released the first version of our cybersecurity framework. We brought people from the nation’s financial, energy, healthcare, and other critical sectors together to work out a way that they could better protect their information and physical assets from cyber-attack.
- The framework describes the characteristics of a comprehensive cybersecurity program, complete with standards, guidelines, and practices that organizations of any size can use to manage their risks.
- The framework is voluntary. It’s not a prescription. And it’s a living document. It is open to constant revision as the information security landscape changes, but it is a starting point, and a way forward to ensuring that at least the most vital sectors of our infrastructure are hardened against hackers.

VCAT Report

On another cybersecurity - related note: due to the allegations made in one of the Edward Snowden leaks, we (NIST) charged our primary independent advisory panel, the Visiting Committee on Advanced Technology (VCAT), to oversee a review of our Cryptographic Standards and Guidelines Development Process. The allegation was in regard to a faulty random number generator baked into one of our Cybersecurity Standards, which NIST obtained from NSA.

The VCAT asked a blue ribbon Committee of Visitors (COV) to assess NIST’s existing cryptographic standards and guidelines and the process by which those standards and guidelines are developed. Each COV member provided an independent report to the VCAT.

That “blue ribbon” Committee of Visitors included:

- **Vint Cerf** of Google;
- **Edward Felten** of Princeton University;
- **Steve Lipner** of Microsoft Corporation;
- **Bart Preneel** of Katholieke Universiteit Leuven;
- **Ellen Richey** of Visa Inc.;
- **Ron Rivest** of the Massachusetts Institute of Technology (MIT); and
- **Fran Schrotter** of the American National Standards Institute (ANSI).

The VCAT took this input and made recommendations to NIST that fall into four basic categories:

They asked that we:

- Assure that our (NIST’s) process for producing standards and best practices is open and transparent.
- Increase our capability and capacity in cryptography – so that we **were not dependent** on NSA for input.
- Increase the involvement of the cryptographic community, including academia and industry, in our standards-development process.
- Review and clarify our relationship with NSA.
- Following up on something that I discussed with you last year, NIST and the Department of Justice have also just recently named the members to the first forensic science standards board, which we established to improve the scientific basis of forensic evidence used in courts of law.
- Some of you may be surprised to learn that, much like the nation’s weights and measures system used to be, there are few national standards or uniformity in forensic science. The confidence that a forensic scientist has in how well a piece of evidence connects a suspect to a crime is largely a matter of his interpretation. It may not be based on any objective standards.
- This lack of national uniformity is reflected in every forensic science discipline. How many points of comparison do you need to say conclusively that a fingerprint found at a crime scene belongs to the suspect? What about the marks left on a shell casing or even DNA?
- A new forensic science board, which is modeled on the structure of the NCWM, will be dedicated to answering these questions, and to establishing a uniform system of national standards that will ensure that evidence is collected, analyzed, and interpreted the same no matter where a crime is committed.
- No one wants to see the innocent go to prison for crimes they didn’t commit.
 - When the innocent go to prison, the guilty go free.
 - Objective standards will help improve our justice system.

ADVANCED COMMUNICATIONS

- NIST’s initiative in advanced communications got a boost earlier this year when the former operations director for our labs in Boulder, Colorado, Kent Rochford, returned from a year and a half stint with Sharp

Electronics to lead our new Communication Technology Laboratory and Center for Advanced Communications – a joint venture with the National Telecommunications and Information Administration.

- The proliferation of cell phones and other communication technologies has begun to really eat up the electromagnetic spectrum. The airwaves are simply getting crowded. The new center’s mission is to advance our understanding of the wireless spectrum and to foster innovations that will make wireless communications faster and more reliable.

HYDROGEN FUEL VEHICLES

- Now, getting back to the Motor City theme, three automakers plan to begin selling hydrogen-fueled vehicles to consumers in 2015. Now, once you have these zero-emission vehicles on the road, you need a place to fill them up. And if you are building refueling stations, you need a way to make sure that that fuel is being dispensed accurately.
- Our researchers have recently completed work on a new field test apparatus to confirm the accuracy of hydrogen fuel dispensers. Once the standard is fully tested, we plan to offer it as a model for constructing “Provers” for state weights and measures inspectors to use.
- The state of California has really gotten behind hydrogen-fuel-cell vehicles and is putting the infrastructure in place to support them. They’ve opened nine refueling stations so far, and they are funding the construction of an additional 28 stations over the next few years. They plan to fund the construction of 100 in total.
- This body recently adopted standards for the sale of hydrogen. NIST Handbook 44 reads that hydrogen will be sold by the kilogram, and that hydrogen-dispensing pumps must be accurate to within plus or minus two percent, or plus or minus 20 grams per kilogram.
- So while a kilogram of hydrogen has approximately the same energy content as a gallon of gasoline, the allowable error is a little less stringent than for gasoline.
- Some have argued that even these larger tolerances are too tight, and that errors as high as 10 or 20 percent should be allowed. It’s hard to see how that would be fair for anyone. Our preliminary tests have shown that the flow meters used to dispense hydrogen fuel are capable of doing so with an error as little as one percent or less. Why would we allow less than the best measurements we can make? Shouldn’t we always aim to achieve the highest accuracy, the most transparency, and the fairest system?
- Mass flow meters dispense according to weight, the standard for weight in the United States is the kilogram, and it has been since 1893. It makes sense that it would be sold in the same terms in which it was measured. **I understand that you have a similar question before you this week.**
 - An important decision needs to be made regarding the sale of liquefied natural gas.
- I know that people have strong opinions about this issue and that you have been studying the issue intently. NIST’s scientific position is well-known, so I won’t repeat it here, but I will urge you to remember the consumer when you are voting this week and remember the importance of having and promoting a rational, science-based measurement system.

Let me close by discussing “RATIONAL MEASUREMENT UNITS”

- You know, one of the reasons that the metric system came into being is because the French had found the old way of doing things had become untenable.
 - By the time of the French Revolution there were as many as 250,000 different measurement units. Each commodity had its own measure, and there was little uniformity between them. There was

no way to know definitively that a wine gallon in Marseilles was the same as a wine gallon in Paris—no doubt very distressing, especially if you are French.

- It was hard to do business without a science-based system.
- After a few stops and starts, the French succeeded in creating something beautiful, a system of units the entire world could use.
- Back when NIST was founded, the United States was in sort of the same fix as France had been. While our nation was a signatory to the Treaty of the Meter – and its international units for measurement – the Congress did not make its adoption mandatory.
- What we had was a system that we inherited from our Forbearers – some units we simply just invented in various locales.
 - We had eight different gallons and four different feet and very little in the way of agreement between them.
- Way back in 1909, when NIST and the newly formed NCWM were investigating the state of U.S. legal metrology, they found that in many of the states “official” weights and measures were in a state of severe disrepair, if they could be found at all.
- In many states, even having a standard set of weights or measures was not required by law.
 - For the most part, the state weights and measures inspector was not a paid position, **and at the county level, that job usually fell to the treasurer, or even the school superintendent.**
- A survey of over 30 000 scales being used in more than 3,000 shops and stores across the nation found half of them to be woefully inaccurate and most frequently favored the shopkeeper – surprise, surprise.
- But with the efforts of the hardworking men and women of the NCWM, the situation quickly improved.
 - The people in our country had resigned themselves to the thought that there would always be cheating – that a fair deal was just not to be had.
 - There could be no trust in the marketplace.
- But the NCWM, **and a good dose of bad press**, turned that all around.
 - The American people began to see that corruption and cheating didn’t have to be the norm.
 - They began to see that chaos did not have to reign.
- This body brought fairness, order, and trust to the marketplaces of this country.
- Now, you have gathered here to continue this noble mission.
 - Our citizens are depending on you to look out for their interests.
- I urge you to remember that while you are deliberating this week.
 - Remember that the right thing to do is not always the easiest thing to do.
- I have no doubt that you will live up to this charge.
- Thank you for your attention.

THIS PAGE INTENTIONALLY LEFT BLANK



99th NCWM Annual Meeting
“Meeting Tomorrow’s Challenges Today”
Detroit, Michigan July 15-19, 2014

Honorary President’s Address

Dr. Willie E. May

Associate Director for Laboratory Programs and Acting Director

National Institute of
Standards and Technology



NIST (NBS) established in 1901

“It is therefore the unanimous opinion of your committee that no more essential aid could be given to

- manufacturing
- commerce
- the makers of scientific apparatus
- the scientific work of Government
- schools, colleges, and universities

than by the establishment of the institution proposed in this bill.”

Organic Act of 1901; Updated in 2008

Functions and activities of the Institute include:

- custody and dissemination of national standards
 - comparison of US national standards with those of other nations
- determination of physical constants and the properties of materials,
- solutions to measurement and standards problems of other government agencies
- providing (Innovation) assistance to industry
 - development of measurements, measurement methods and basic measurement technology
 - development of technology and procedures needed to improve quality, modernize manufacturing processes, ensure product reliability and cost-effectiveness, promote more rapid commercialization ...
 - operation of National User Facilities



House Committee on Coinage, Weights and Measures ... on the establishment of the National Bureau of Standards (now NIST) May 3, 1900

NIST – Who We Are and What We Do

NIST is a world class scientific and technical agency uniquely focused on driving innovation and economic competitiveness.

We drive U.S. innovation and economic competitiveness through:

- a world-leading scientific research -- measurement, technology, and standards solutions to our stakeholders
- a nation-wide network of centers -- focused on strengthening our nation’s small and medium manufacturers
- a program in performance excellence -- used to assess the nation’s companies and organizations which is recognized, utilized, and emulated around the world

3

NIST Programs, Presidential Priorities and Department’s Strategic Plan

NIST:

- a key player on the Administration’s Innovation Team
- the nation’s go-to agency for measurements, standards, and technology

Providing measurements, standards and technology in areas a national importance , e.g.

- **Advanced Manufacturing**
- **Advanced Communications**
- **Cybersecurity**
- **Disaster Resilience**
- **Environment and Energy**
- **Forensic Science**
- **Verification of GHG Inventories**



NIST-at-a-Glance

Major Assets

- ~ 3,000 Employees; 1800 Scientists and Engineers
- ~ 2,800 Associates and Facilities Users
- ~ 400 NIST Staff on ~1,000 national and international standards committees

NIST FY 2014 Congressional Appropriations \$850

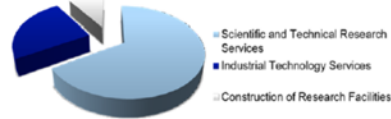

Plus
~ \$120 M from other Government Agencies
~ \$50 M for other reimbursable services

NIST has two main campuses.....



Gaithersburg, MD
62 buildings; 578 acres



Boulder, CO
26 buildings; 208 acres

- + two sites housing NIST radio stations:
- Ft. Collins; 390 acres
 - Kauai; US Navy 30 acre site

and six joint institutes

- JILA – *amo physics*
- JQI – *quantum science*
- IBBR – *biotech – adv. therapeutics*
- HML – *marine bioscience*
- NCCoE – *cybersecurity*
- CHiMaD – *“materials by design”*

NIST Laboratory Program

providing measurement solutions for industry and the nation

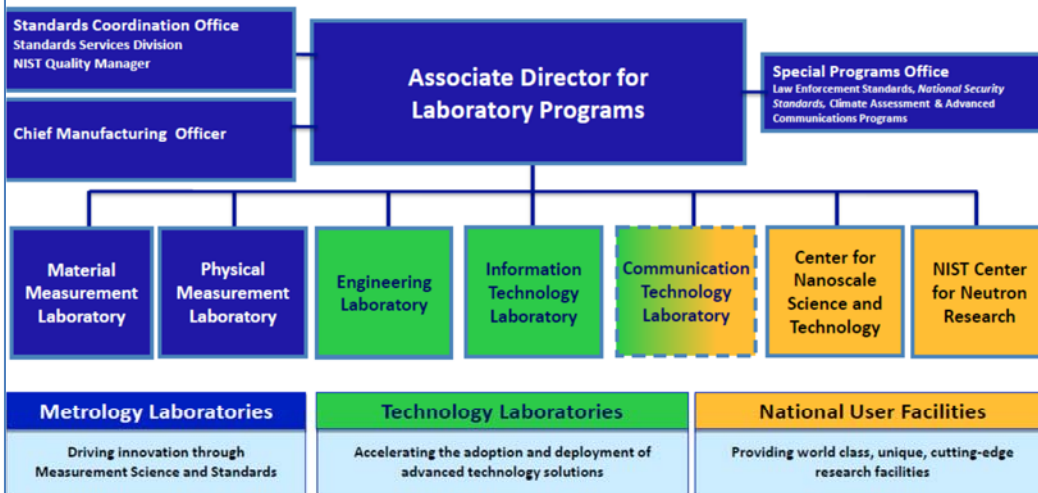

Automotive Lightweighting

Industry Goal - CAFE of 39 MPG by 2016

Auto industry needs to incorporate advanced lightweight alloys in automobiles to help meet increased fuel efficiency requirements

Industry Needs

- Data and models the auto industry uses to optimize the design and manufacture of traditional metal parts are not applicable.
- So, US industry is spending \$10 million+ on trial-and-error testing to optimize manufacturing protocols for these advanced alloys
- Material property data/models/tests are needed that are applicable for these materials. E.g.,:
 - Methods to assess “strain” on a material under manufacturing conditions, i.e., stretches and bends in multiple directions simultaneously and not just one at a time
 - predicting springback, when a part changes shape after it has been formed
 - determining the crashworthiness of lightweight alloy components



NIST:

- developing methods to measure multiaxial metal forming that are more representative of actual manufacturing conditions
 - NIST materials deformation data now is being used directly by industry to more efficiently develop forming protocols for lightweight alloys
- led the development of ASTM 2462: Springback Cup Test, recently adopted for industry use
- developing high-rate deformation tests to better assess performance in crashes

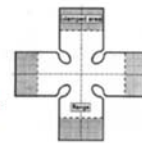
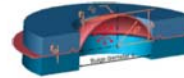

National Network for Manufacturing Innovation



Additive Manufacturing
 DOD – Youngstown, OH



Power Electronics
 DOE – Raleigh, NC

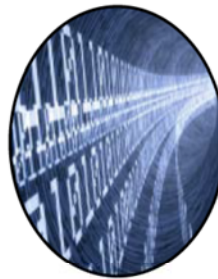

Digital Manufacturing
 DOD – Chicago, IL



Lightweight Metals
 DOD – Detroit, MI



Adv. Composites Mfg.
 DOE – TBD



Net-Zero Energy Residential Test Facility Exceeds Goal

- The Net-zero Energy Residential Test Facility ended its one year study period with:
 - Savings of over \$4300/year or \$364/month in electricity bills, by the home’s virtual residents
 - Plus, a *net positive energy balance* of 491 kwh, enough energy to drive an electric car 1440 miles.
- Moving forward, this facility will be used to provide the scientific basis for tests and standards for building energy efficiency and environmental performance

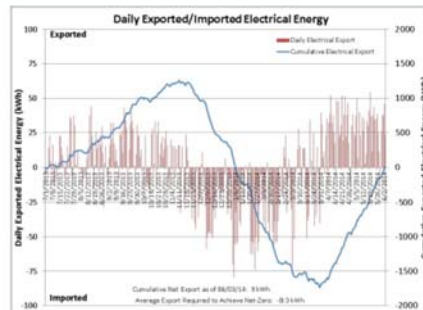

Program Update: Improving Critical Infrastructure Cybersecurity a.k.a. Cybersecurity Executive Order (EO)

“...America must also face the rapidly growing threat from cyber attacks. I signed a new executive order that will strengthen our cyber defenses by increasing information sharing, and developing standards to protect our national security, our jobs, and our privacy...”

- President Obama in the 2013 State of the Union Address

- Leverages two key NIST roles – as a convener and as a technical agency
- NIST to developed standards framework to reduce cyber risks to critical infrastructure (the "Cybersecurity Framework").
- Partnered with industry, standards organizations and government agencies



Credit: K. Tabor/NIST & Shutterstock



Author: P.Khao
Creative Commons License

Report Released on NIST Cryptographic Standards Program

The VCAT recommendations to NIST fall into four basic categories:

- Improve NIST’s open and transparent process when producing its standards and best practices,
- Increase NIST cryptographic capacity,
- Increase the involvement of the cryptographic community, including academia and industry, in the standards-development process,
- Review and clarify NIST’s relationship with NSA.

11

Helping Strengthen the “Science” in Forensic Science

A landmark forensics report by U.S. National Research Council of the National Academies was issued in Feb. 2009.

“With the exception of nuclear DNA analysis, no forensic method has been rigorously shown to have the capacity to consistently, and with a high degree of certainty, demonstrate a connection between evidence and a specific individual or source.”



NIST is committed to strengthening forensic science to provide greater transparency, rigor, and confidence in forensic evidence used in the criminal justice system.

- **Co-Chairing the National Commission on Forensic Science** (with DoJ)
 - to help improve the reliability of forensic science data/information and to develop policy recommendations for the U.S. Attorney General.
 - to be comprised of forensic science practitioners, academic researchers, prosecutors, defense attorneys, judges, and other relevant stakeholders
- **Building out and supporting the OSAC**
- **Conducting laboratory-based research to...**
 - **Validate select existing forensic science methods and guidance**
 - **Develop and critically evaluate new methods**

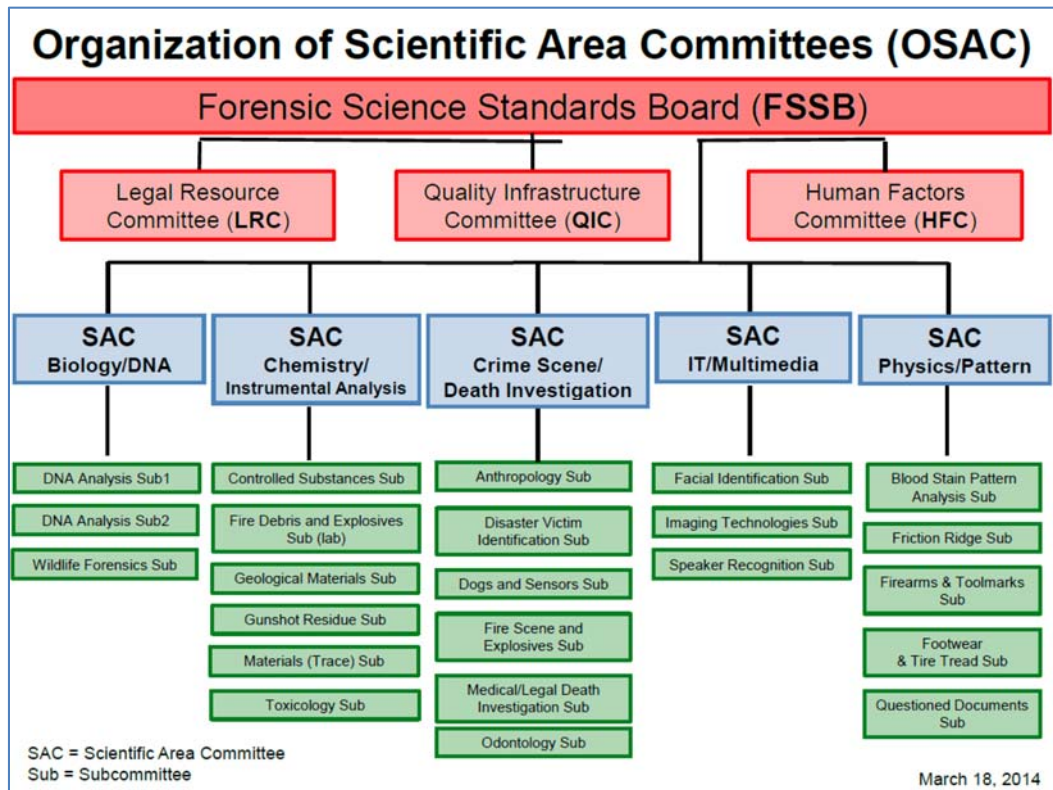

New Communications Technology Laboratory Established

The CTL promotes the development and deployment of advanced communications technologies through the conduct of leading edge R&D on both the metrology and understanding of physical phenomena, materials capabilities, complex systems relevant to advanced communications; and through the conduct of research targeted at supporting a multi-level testbed facility.

Material Measurement Laboratory	Physical Measurement Laboratory	Engineering Laboratory	Information Technology Laboratory	Communication Technology Laboratory	Center for Nanoscale Science and Technology	NIST Center for Neutron Research
Metrology Laboratories		Technology Laboratories			National User Facilities	
Driving innovation through Measurement Science and Standards		Accelerating the adoption and deployment of advanced technology solutions			Providing world class, unique, cutting-edge research facilities	

Initial Areas of Focus:

- **Public Safety Communications Research (PSCR)** –PSCR has moved into CTL from the Office of Special Programs. Near-term, CTL will increase PSCR technical staff and enhance the LTE laboratory infrastructure to increase support for public safety communications.
- **Spectrum Sharing** – Working through the joint NTIA/NIST Center for Advanced Communications, and the National Advanced Spectrum and Communications Test Network, CTL will create a trusted capability to facilitate spectrum sharing studies, optimize access to engineering capabilities, and engage spectrum users in collaboration.
- **Develop R&D programs-** Working with stakeholders, CTL will develop strategic plans for high value R&D

Needs for Measurement Standards in the U.S.



Article I, Section 8: The Congress shall have the power to...*fix the standard of weights and measures*

National Bureau of Standards established by Congress in 1901

- Eight different “authoritative” values for the gallon
- Electrical industry needed standards
- American instruments sent abroad for calibration
- Consumer products and construction materials uneven in quality and unreliable

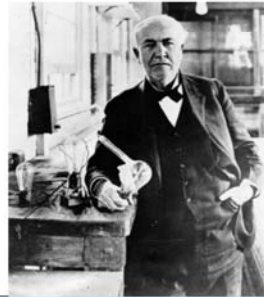

Currently, it is estimated that 80% of global merchandise trade is influenced by testing and other measurement-related requirements of regulations and standards



Thanks for Your Attention

Willie E. May
*Associate Director for Laboratory Programs & Acting Director
National Institute of Standards and Technology
100 Bureau Drive
Gaithersburg, Maryland 20899-1000*

*(301) 975-2300
wem@nist.gov*



Questions and Comments?



Chairman’s Address
National Conference on Weights and Measures
Detroit, Michigan
July 17, 2014
John Gaccione
Westchester County, New York

Thank you Director Hockert.

It is my pleasure to welcome everyone here to the 99th Annual Meeting of the National Conference on Weights and Measures here in Detroit. We have over 250 attendees, the most in over 15 years. At our meeting in January, we had over 150 attendees, near record attendance for an Interim Meeting. The Executive Director passed along that it was a great year for NCWM attendance and everyone worked hard to get the word out about the regional meetings and the NCWM Meetings. When I asked at one of the Board of Directors meetings if the attendance increase had to do with who is the Chairman, there was a long awkward silence followed by quick motion to adjourn. Thank you all for attending and for participating.

I want to take a minute to thank our distinguished guests, Dr. May, Acting Under Secretary for Standards and Technology and Acting Director of NIST, Chief Deputy Director Wenk of the Michigan Department of Agriculture and Rural Development, and Carol Hockert, Director of the NIST Office of Weights and Measures.

Thanks go to the City of Detroit and to Craig VanBuren and his staff for all they have done to welcome us to Michigan. To our presiding officers, thank you Jack Walsh, Jerry Butler, Marco Mares, and Scott Ferguson.

Please take a minute to look around the hotel and the surrounding area. I would say that Detroit is a city on the rise.

Thanks to the NCWM Staff: Don, Jim, Elisa (who if you didn’t know, started the year with the last name of Robertson and switched along the way to Stritt (congratulations Elisa), Tyler, and to Darrell.

My theme at the beginning of my tenure as chairman was “Meeting Tomorrow’s Challenges Today.” Well Folks, tomorrow’s challenges are here. We talked about some of the challenges yesterday. Examples include:

- CNG/LNG fueling for everyday on-road vehicle use;
- electric vehicles and the ability to charge those vehicles and travel hundreds of miles between charges; and
- railroad scales that speed up the weighing of freight by two to three times.

Another challenge was to continue to support the regions, and in turn, the jurisdictions that make up those regions. We continued and expanded the Train the Trainer Program. With NIST’s help, we began to help not just the supervisors, but the field inspectors. On the NCWM webpage, we now have a list of certified trainers available to help the regions and their jurisdictions.

We continued to expand the Professional Certification Program. As mentioned earlier, more exams will be brought online, expanding the number of available exams.

NCWM has faced this year’s challenges. NCWM rose to its challenges. NCWM welcomes new challenges.

Being Chairman brings with it a two to three page list of responsibilities and duties. When I first looked at that list, it became an “uh oh” moment.

General – 2014 Final Report
Chairman’s Address

We have L and R; we have S and T; we have PDC, WWMA, and CWMA, SWMA, and NTEP and so on and so on. I didn’t get the cheat sheet of abbreviations and acronyms.

I have to tell you that being associated with the employees of NCWM has been nothing less than terrific. They work hard, put the interests of the members first, and provide a level of service second to none. Look at how well these past few days have gone.

To my fellow board members, thanks for making it easy to be the Chairman. The Board of Directors this year faced a number of issues. We took them all in stride and did what was best for the Conference. We recognized a need and added the necessary staff.

Part of being Chairman includes traveling to each of the regional meetings. To me it wasn’t an obligation or chore, it was a pleasure. At each of the regions, I spoke about how NCWM could and would support the region, and how well supported regions help NCWM. The NCWM model works and it works well.

In preparing for today, I was looking for a phrase, an adage, or a line from a song that would put in context my regional experiences. Something that could sum it all up, some phrase everyone could relate to, and something that was, yes, probably corny.

Some years back, there was a Broadway Show called “Rent.” Some of you may have seen the movie. Part of the chorus of one of the songs is; “How do you measure, measure a year.” Perfect for a weights and measures official.

The song continues:

“Five hundred twenty five thousand six hundred minutes, how do you measure, measure a year.”

How did I measure this year? I measured it in people (hundreds). I measured it in regions (four). I measured in national meetings (two).

Historians say it was Horace Greeley, the famous 19th century author and newspaper publisher that said “Go west young man, go west.” It wasn’t. It was really Kurt Floren of Los Angeles County, California, who said it.

This year the Western Regional had almost 100 attendees and representation from every state in the region except two - very impressive. That’s the most for any of the 2013 - 2014 regionals. Thanks to Mahesh Albuquerque, the Western Regional Chair, and the host State of Montana.

Just as an aside, Kurt never stopped reminding me we were at the Western Regional and how the Western is first of the regional cycle. I had to constantly remind him of the east coast – west coast, right coast – left coast rivalry. We continued, and I finally remarked that he lived three hours behind civilization. Without hesitation, Kurt recommended I visit Santa Monica, California, for a long walk on a short pier.

Next was south to West Virginia. I decided to drive to Charleston (about 11 hours) and what a great ride it was. Again, excellent attendance at a regional meeting – about 70 attendees and only 2 states didn’t have representation. The Southern Region has two Commonwealths and many thanks to Rich McComas and the State of West Virginia for their hospitality.

When arriving at the Southern Regional Meeting, I was greeted by the ever smiling Tim Chesser of Arkansas. Tim gave me a warm welcome, and said John, “Don’t worry about a thing; I will take care of everything.”

Everyone has a moment of revelation, an “ah hah” moment; this was an “oh no” moment.

Next was to the Northeast Region to Manchester, New Hampshire. To NEWMA, the little region that could, don’t dare tell them they can’t. Yet meeting attendance wasn’t so little with 50 attendees, and again, only 2 states not represented and another region with two Commonwealths. Thanks to Chair Lou Sakin and to the host State of New Hampshire. As always, NEWMA lived up to its hard working, hard playing reputation. Anything else about the NEWMA Annual Meeting can be read in the Manchester, “New Hampshire Police Blotter.”

And, finally to Central, 75 attendees and only 2 states not represented. Again, great attendance; many thanks go to Ron Hayes, our Chair-Elect. After a long and sometimes heated discussion about how to pronounce the name of the host state between members of the host delegation, I ended up leaving there the same as I came, not knowing whether to say Missoura or Missouri?

At several of the regions, I was asked which region I liked the most, what region was best at this or best at that. My carefully worded response was and continues to be, every region was great, every region was unique, and every region had great hospitality rooms.

NCWM is about equity. It is about a safe and fair marketplace. NCWM is about its people.

There was something I repeated at each of the regions. I reminded everyone that the work they do affects everyone in the marketplace almost every day. Let’s not forget that.

So again, thank you to everyone for attending and participating, and thank you for making NCWM the successful organization that it is.

THIS PAGE INTENTIONALLY LEFT BLANK

Chairman Elect’s Address
National Conference on Weights and Measures
Detroit, Michigan
July 17, 2014

Ronald G. Hayes

“One Hundred Years: Building on the Past”

I feel so very honored to stand before you as the Chairman of the National Conference on Weights and Measures, especially on the eve of the 100th meeting and the 110th anniversary. I want to thank those that have given me guidance in preparing me for this role.

As I looked back at agendas of past chairs of the Conferences, I noticed the goals set for the Conference could not always be met in the short one-year term. Many times these goals were not implemented until after their term expired. In 1991, N. David Smith from North Carolina was Chairman of the Conference. His vision was to establish a Petroleum Subcommittee to expand from a basic petroleum laboratory guide and develop fuel quality laws and regulations. This Subcommittee is, of course, now known as FALS. States such as Minnesota, Tennessee, Illinois, New York, and Michigan had already committed resources to improve the quality of fuels. This idea would take a few years to complete and the following chairman, Mr. Sid Colbrook from Illinois, appointed the Committee, comprised of both public members and industry representatives. A few of the original appointees, who are still active, are at this meeting. It was a great pleasure for me to read the Distinguished Service Award given to Mr. Randy Jennings, State of Tennessee, for continuous excellence of service on the Fuels and Lubricants Subcommittee.

Goals:

1. Continue the enhanced training by NIST.
2. Build closer relationships with other standards development organizations.
3. Establish a more effective communication plan with federal agencies.

In the last few years, under the leadership of Ms. Carol Hockert, NIST has placed more instructors throughout the nation, increasing training on fundamentals of weights and measures functions. This also complements the current NCWM Certification program.

From the very beginning of the National Conference on Weights and Measures, we have partnered with other standards development organizations, such as the American Society for Testing and Materials, scale manufacturers associations, the American Petroleum Institute, Gas Pump Manufacturers Association, and others. As new ways of measuring commodities evolved, we gained working relationships with other standards writing organizations. For example, in 2011 we allowed seed count for agriculture seed. Without an automatic seed counter, it would not have been possible to verify seed count claims. Thanks to the American Seed Trade Association and the Association of Official Seed Analysts, we were able accept the use of seed counter devices.

Our standards often reference standards from other standard writing organizations. However, I think it’s time we have our standards recognized in more federal and industry standards. NCWM and other standards organizations need to complement each other’s standards when we can. For example, PEI has several standard practices for storage tanks. Our labeling requirements could be referenced in their documents making their standards more complete.

In the last month, letters from PALS and FALS were sent to the FTC on separate proposed rules. A more effective communication plan with federal agencies will allow NCWM and federal agencies to be more efficient in both of our regulatory roles.

I am looking forward to the next 12 months. I will continue to enjoy my interaction with each regional association and each opportunity to share our knowledge with each other.

Appointments

Specifications and Tolerance Committee:

- Ivan Hankins, Iowa, five-year term

Laws and Regulations Committee:

- Kristin Macey, California, five-year term

Professional Development Committee:

- Angela Godwin, Ventura County, California replacing Kristin Macey, two-years term
- Dale Saunders, Virginia

Nominating Committee:

- Committee Chair – John Gaccione, Westchester County, New York
- Judy Cardin, Wisconsin
- Charles Carroll, Massachusetts
- Randy Jennings, Tennessee
- Joe Gomez, New Mexico
- Kurt Floren, Los Angeles County
- Steve Benjamin, North Carolina

Parliamentarian:

- Louis Straub, Fairbanks Scale, Inc.

Chaplain:

- Stephen Langford, Cardinal Scale Manufacturing, Co.

Credentials Committee:

- Ethan Bogren, Westchester County, NY

Presiding Officers:

- Lawrence Nolan, Los Angeles County
- Jack Walsh, Town of Wellesley, Massachusetts
- Tim Chesser, Arkansas
- Marco Mares, San Diego County, California

Again, thank you for the privilege of being asked to serve on this incredible conference.

2014 National Conference on Weights and Measures Special Award Recipients

Contributions Award: Mr. Nigel Mills, Hobart (accepted by Mr. Rob Upright, President of Scale Manufacturer's Association (SMA) on behalf of Mr. Mills.



Figure 1. Left to Right: Mr. John Gaccione, NCWM Chairman; Mr. Rob Upright, SMA President; and Dr. Willie May, NCWM Honorary President.

Distinguished Service Awards: Mr. Randy Jennings, Tennessee, and Mr. Joe Gomez, New Mexico.



Figure 2. Left to right: Mr. John Gaccione, NCWM Chairman; Mr. Randy Jennings, Tennessee; and Dr. Willie May, NCWM Honorary President.

Figure 3. Left to Right: Mr. John Gaccione, NCWM Chairman; Mr. Jeff M. Witte, Director/Secretary of Agriculture; Mr. Joe Gomez, New Mexico; and Dr. Willie May, NCWM Honorary President.



Lifetime Achievement Award: Mr. N. David Smith, North Carolina.



Figure 4. Left to right: Mr. John Gaccione, NCWM Chairman; Ms. Pam Smith; and Mr. N. David Smith, North Carolina.

Attendance Recognition:

5 Years

- Richard Harshman
- Paul Menard
- Sam Bell

10 Years

- Hal Prince
- Carol Hockert
- Kristin Macey
- Steven Beitzel
- John Gaccione

15 Years

- Clark Cooney
- Joe Gomez
- James Cassidy

20 Years

- Randy Jennings

25 Years

- Ron Hayes

45 Years

- Joseph Silvestro

Report of the Board of Directors (BOD)

Mr. John Gaccione, NCWM Chair
Westchester County, New York

100 INTRODUCTION

This is the report of the Board of Directors (BOD) (hereinafter referred to as the “Board”) for the 99th Annual Meeting of the National Conference on Weights and Measures (NCWM). This report is based on the Interim Report offered in the NCWM Publication 16, “Board Report,” testimony heard at public hearings, comments received from the regional weights and measures associations and other parties, the NCWM 2014 Online Position Forum, the addendum sheets issued at the Annual Meeting, and actions taken by the membership at the voting session of the Annual Meeting. The voting items presented below were adopted as presented when this report was approved.

Table A identifies the agenda and appendix items by reference key, title of item, page number and the appendices by appendix designations. The acronyms for organizations and technical terms used throughout the agenda are identified in Table B. The first three digits of an item’s reference key are assigned from the Subject Series List. The status of each item contained in the report is designated as one of the following: **(D) Developing Item:** the Committee determined the item has merit; however, the item was returned to the submitter or other designated party for further development before any action can be taken at the national level; **(I) Informational Item:** the item is under consideration by the Committee but not proposed for Voting; **(V) Voting Item:** the Committee is making recommendations requiring a vote by the active members of NCWM; **(W) Withdrawn Item:** the item has been removed from consideration by the Committee.

Table B provides a summary of the results of the voting on the Committee’s items and the report in its entirety. Some Voting Items are considered individually, others may be grouped in a consent calendar. Consent calendar items are Voting Items that the Committee has assembled as a single Voting Item during their deliberation after the Open Hearings on the assumption that the items are without opposition and will not require discussion. The Voting Items that have been grouped into consent calendar items will be listed on the addendum sheets. Prior to adoption of the consent calendar, the Committee entertains any requests from the floor to remove specific items from the consent calendar to be discussed and voted upon individually.

Note: It is the policy to use metric units of measurement in publications; however, recommendations received by NCWM technical committees and regional weights and measures associations have been printed in this publication as submitted. Therefore, the report may contain references to inch-pound units.

Subject Series List

Introduction	100 Series
Activity Reports.....	110 Series
Strategic Planning, Policies, and Bylaws.....	120 Series
Financials.....	130 Series
Other Items – Developing Items.....	140 Series

**Table A
Table of Contents**

Reference Key	Title of Item	Page BOD
100	INTRODUCTION	1
110	ACTIVITY REPORTS.....	4
110-1	I Membership and Meeting Attendance	4
110-2	I NCWM Newsletter and Website.....	5
110-3	I Meetings Update.....	7
110-4	I Participation in International Standard Setting	7
110-5	I Associate Membership Committee Activity	8
120	STRATEGIC PLANNING, POLICIES, AND BYLAWS.....	9
120-1	I Strategic Planning	9
120-2	I Regional Support	11
120-3	I Standing Committees Support	11
130	FINANCIALS.....	14
130-1	I Financial Report.....	14

Appendices

A	Item 110-4: Report of the Activities of the International Organization of Legal Metrology (OIML) and Regional Legal Metrology Organizations	A1
B	Item 110-5: Associate Membership Committee (AMC) Agenda and Draft Meeting Minutes.....	B1

**Table B
Voting Results**

<i>Reference Key Number</i>	<i>House of State Representatives</i>		<i>House of Delegates</i>		<i>Results</i>
	<i>Yeas</i>	<i>Nays</i>	<i>Yeas</i>	<i>Nays</i>	
To Accept the Report	Voice Vote				Adopted

Table C
Glossary of Acronyms and Terms

Acronym	Term	Acronym	Term
AMC	Associate Membership Committee	NIST	National Institute of Standards and Technology
CTT	Conformity to Type	NTEP	National Type Evaluation Program
ISWM	International Society of Weighing and Measuring	OIML	International Organization of Legal Metrology
MAA	Mutual Acceptance Arrangement	OWM	Office of Weights and Measures
L&R	Laws and Regulations Committee	PDC	Professional Development Committee
NCWM	National Conference on Weights and Measures	VCAP	Verified Conformity Assessment Program

Details of All Items
(In order by Reference Key)

110 ACTIVITY REPORTS**110-1 I Membership and Meeting Attendance**

Membership levels have remained fairly steady for the past several years. NCWM continues to conduct outreach to stakeholders and there are very few states or territories that have not maintained membership. The Board has discussed the reduced pool of potential members, especially regulatory officials, as a result of downsized or eliminated programs from budget cuts. Still, the potential growth in membership is significant and NCWM continues to enhance programs and services that add value to membership. The price structure for the exams is set to heavily favor membership as an alternative to paying non-member exam fees.

The following is a comparison of NCWM membership levels as of June 30 for recent years.

Year Type	6/14	6/13	6/12	6/11	6/10	6/09	6/08	6/07	6/06
Associate	802	818	842	813	814	822	848	863	837
Foreign Associate	64	50	58	62	53	53	56	53	61
Total Associate	866	868	900	875	867	875	904	916	898
State Government	603	558	589	567	565	696	831	825	812
Local Government	492	486	487	495	524	558	554	565	492
Total Active	1095	1044	1076	1062	1089	1254	1385	1390	1304
NIST	16	16	16	16	12	14	15	14	12
Other Federal Government	9	10	11	11	12	10	9	9	13
Foreign Government	13	13	14	14	12	24	22	31	23
Retired	207	198	195	202	196	196	232	221	215
Total Advisory	245	237	236	243	232	244	278	275	263
Grand Total	2206	2149	2212	2180	2188	2373	2567	2581	2465

Annual Membership Totals

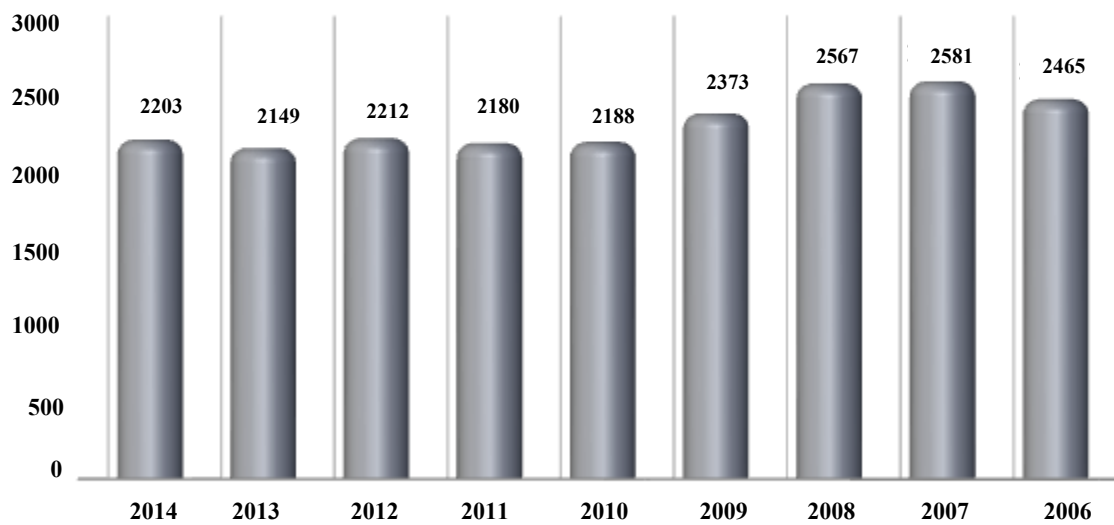

The attendance for the 2012, 2013, and 2014 Interim Meetings has been exceptional, with the highest being this year in Albuquerque, New Mexico. NCWM had the pleasure of welcoming back a number of jurisdictions to our Interim and Annual Meetings in 2013 and 2014. The overall attendance for the 2014 Annual Meeting was the highest in 12 years and included 42 seats in the House of State Representatives. This is an exciting trend as we plan for the upcoming 100th Annual Meeting in 2015 in Philadelphia. See Item 110-3 for information on that and other future meetings.

110-2 I NCWM Newsletter and Website

Newsletter:

The Board continuously considers ways to monitor and improve the content of the newsletter and website. Members are encouraged to bring ideas and articles forward for inclusion in newsletters. Of particular interest are articles that would be pertinent to field inspectors and the service industry.

Website Improvements:

The NCWM website continues to evolve as ideas are submitted for content enhancement. Many small improvements are made on a regular basis through better use of the space and tools already in place.

In February 2014, a list of trainers was added under the “Resource” tab. These are trainers who have acquired training skills through participation in Train-the-Trainer courses sponsored by NIST. Along with the trainers’ names, the page provides the technical areas that each is comfortable presenting in a training class. There is also a page that provides information about upcoming training events around the country.

Among other added features on the new website, the most popular are the mobile-friendly version which is very effective for searching the NTEP Certificate database, downloading Certificates of Conformance, and the ability for NTEP applicants to complete their applications online. There are many other features that make the new website a better customer experience.

Because the mobile-friendly version was so well-received, NCWM received a request to implement a similar feature for the regional websites. Each of the four regions agreed to the cost of \$550 per site to implement this feature that provides “About,” “Meetings,” and “Contact” in the mobile version with a link to view the full site. The “Meetings” portion gives the user easy access to the meeting information including links for hotels, registration, and the meeting documents, which download to the mobile device with impressive speed. The feature is fully implemented on all four regional sites.

Comments and suggestions for improvements to the newsletter and website should be directed to NCWM at (402) 434-4880 or info@ncwm.net.

Online Position Forum:

The purpose of the Online Position Forum is to help members prepare for the deliberations and voting at the Annual Meeting in July by having a better idea of positions others may have.

Beginning in 2014, the Forum was reconfigured so that members can view the comments and positions that others have submitted prior to submitting their own. However, the site is not a blog. Once a member submits positions, that member cannot submit more positions. It was hoped this change would promote increased use of the Forum. Chairman John Gaccione announced at the 99th NCWM Annual Meeting in 2014 that the Board will consider possible suspension or termination of the Online Position Forum due to very limited participation.

The Online Position Forum is not a voting system. Comments and positions entered there are not binding. It is instead a method to present positions, opinions, and supporting documents. All Active, Associate, and Advisory members have the opportunity to login, view committee agenda items, enter positions and comments, and even upload supporting pdf documents for each agenda item of standing committees or the Board.

NCWM notifies members when the forum is ready for them to enter their comments each spring. Positions and comments will be accepted through June 15. The options for each agenda item are:

- Support
- Support with Comments
- Oppose with Comments
- Neutral
- Neutral with Comments

NCWM Visibility:

NCWM shares many news articles and other items of interest to the weights and measures community on the social networks. This has increased interest in the social network accounts with Facebook, Twitter, and LinkedIn. Now, NCWM has contracted with another service provider that offers improved visibility without increased costs. This service provider is optimizing NCWM's visibility on the Internet through the combined use of social media and more frequent press releases on a wide variety of subject matters. The goal here is to elevate NCWM as a recognized resource on a vast array of subjects.

In 2014, NCWM switched to a new service for issuing press releases. The new service provides comprehensive national distribution at a much lower cost. NCWM is now able to put out as many as two press releases per month for about the same cost as doing four press releases in a year under the old service. In that first six months of 2014, NCWM has averaged one press release per month compared to two or three press releases per year in the past.

Professional Certification Program:

The Professional Certification Program exam services are now fully integrated with NCWM's website. Applicants no longer need to wait for staff assistance before they receive their login credentials. Individuals log in at www.ncwm.net to "purchase" exams, though the fees are waived for members. The fee for non-members is \$75 per exam. As orders are received, the applicant receives an automated e-mail with credentials and instructions for accessing the exam. An applicant who does not pass the exam in the first attempt may have one retake. After that, it will be necessary to reapply.

Certification is now available in three areas, including:

- Retail Motor Fuel Dispensing Systems
- Package Checking Basic
- Small Capacity Weighing Systems Class III

NCWM is ramping up its efforts to secure enough Subject Matter Experts to assist in developing more exams. The Certification Program Coordinator is not permitted to write the exams; so this effort is imperative as a means of getting the assistance needed so this program can develop more quickly. One relatively untapped area is with recently retired regulatory officials. Many have not provided NCWM with contact information to continue their complimentary "Retired" status membership; therefore, NCWM is unable to approach them for help in this area. Any assistance is welcomed to reach out to these individuals and have them contact Mr. Onwiler at (402) 434-4871 or don.onwiler@ncwm.net.

See the Professional Development Committee (PDC) Report for information on additional exams under development.

110-3 I Meetings Update

Interim Meetings:

- January 18 - 21, 2015 Hilton Daytona Beach, Daytona Beach, Florida
- January 17 - 20, 2016 Westin San Diego Gaslamp Quarter Hotel, San Diego, California
- January 2017 Considering Orlando, San Antonio, or New Orleans

Annual Meetings:

- July 19 - 23, 2015 **100th Annual Meeting: Sheraton Society Hill Hotel, Philadelphia, Pennsylvania**
- July 24-28, 2016 101st Annual Meeting: Grand Hyatt Denver, Denver, Colorado
- July 2017 102nd Annual Meeting: Considering locations in the Northeastern region.

NCWM strives to plan meetings in locations that offer comfortable rooms and a variety of entertainment and dining options nearby. The following is a brief description of future planned events. We are excited to announce the location for the 2016 Interim Meeting has been booked at the Westin San Diego Gaslamp Quarter Hotel. This was the location of a very successful Annual Meeting in 1994 at the Doubletree Hotel and promises to be a great winter venue.

100th NCWM Annual Meeting:

The 100th Annual Meeting in 2015 promises to be a very special event and one that you will not want to miss. The event will be at the Sheraton Society Hill in Philadelphia, Pennsylvania, with easy access to evening dining and entertainment, as well as daytime access to the historic attractions of Philadelphia. In addition to addressing the business of the organization, NCWM will be celebrating its 100th Annual Meeting, 110 years after our first meeting in 1905. A small Work Group is developing plans for the 100th NCWM Annual Meeting. The Work Group is considering special events and other ideas to commemorate and bring excitement to the occasion. Plans include commemorative gifts, a lunch banquet with a special guest speaker, door prizes including a restored 1950s retail motor fuel dispenser, a restored 1930s candy scale, and more. Suggestions may be forwarded to Ms. Elisa (Robertson) Stritt, NCWM Office Manager, at (402) 434-4872 or elisa.robertson@ncwm.net.

110-4 I Participation in International Standard Setting

Dr. Charles Ehrlich, NIST, OWM, provided a report during Open Hearings of the 99th NCWM Annual Meeting in Detroit, Michigan. An updated report is also included as an appendix to the Report of the Board of Directors (see Appendix A).

See the NTEP Committee Agenda for additional reports on NCWM's involvement internationally, including the Mutual Recognition Arrangement (MRA) with Measurement Canada and the Mutual Acceptance Arrangement (MAA) with OIML.

110-5 I Associate Membership Committee Activity

The Associate Membership Committee (AMC) is organized in accordance with the Bylaws of the National Conference on Weights and Measures, Inc. In addition, AMC operates by its own Bylaws that are available on the Committee pages of www.ncwm.net. AMC meets at least two times per year in conjunction with NCWM's Interim and Annual Meetings. It consists of between 5 and 10 members who, among themselves, elect officers to serve as Chairman, Vice Chairman, and Secretary/Treasurer. AMC has established a reputation of promoting and improving NCWM and has demonstrated its desire to improve understanding of weights and measures activities in public and private sectors.

The membership dues for Associate members (\$90) are higher than that for Active or Advisory members (\$75). The extra \$15 is not for NCWM, but rather is placed in a separate account referred to as the AMC Fund. While AMC has discretion to allocate the funds in various ways, the Committee receives applications and awards training scholarships from the fund in accordance with their "Guidelines for Selection and Approval of Training Funds," which are posted on the Committee's portion of www.ncwm.net. Downloadable scholarship applications and reimbursement forms are also available there or applications may be made online.

The criteria to receive AMC funds for training are as follows:

1. Funding request forms that are complete, specific, and detailed will receive priority attention for approval. Based on the degree of missing or ambiguous information provided, individual requests may not be given any consideration during the AMC review process.
2. Training requests that benefit higher numbers of participants are generally preferred over those for fewer or single-person benefit. Multi-state training that encourages uniformity will also be given priority consideration.
3. In general, attending meetings will not be considered training, especially requests for travel expense or attendance fees for NCWM Annual, Interim, or Regional meetings.
4. As a lower priority, requests for the purchase of training materials will be considered, but requests for purchase of assets (such as LCD projectors) will not.
5. Reasonable funding for travel and expenses will be considered if it is necessary to acquire an "expert trainer" that would benefit a high number of weights and measures officials. This will be an option when qualified volunteers are not available.

Members of AMC have become concerned that the funds are underutilized in recent years. Regulatory agencies are encouraged to make use of these funds to improve training opportunities and the expertise of inspection personnel.

AMC members are also looking for new, perhaps innovative ways to play a more effective role in the NCWM structure in an effort to further improve the organization. Some new initiatives that AMC is discussing include:

- **Promotional Tool-Kit:** AMC has offered funds to assist NCWM in creating a "tool kit" that weights and measures administrators could use to improve awareness and support through adequate funding of their programs. This tool kit could consist of many elements for targeting media, consumers, government administrators, and legislators. AMC has proposed a work group to pursue this project.
- **Tradeshaw Seminars:** AMC is interested in organizing training or awareness seminars at industry type tradeshaws with the idea of reaching out to the smaller industry groups that are impacted by the work of NCWM. This effort would be good for the smaller industries, as well as, providing a possible increase in NCWM membership and participation.

AMC meetings are open to all registered NCWM meeting attendees. All Associate Members are encouraged to attend these meetings, become familiar with the Committee, and offer ideas for how it can further pursue its objectives. *See Appendix B for the AMC Meeting Minutes.*

120 STRATEGIC PLANNING, POLICIES, AND BYLAWS

120-1 I Strategic Planning

The Executive Director presents a strategic plan progress report each year at the fall Board Meeting. The Board conducts a strategic planning session in January at its quarterly meeting just prior to the Interim Meeting. The Board made several updates and changes to the Strategic Plan in January 2014. Members are able to review the Strategic Plan at online at www.ncwm.net. The Board welcomes member input.

There are six NCWM Strategic Plan Goals:

1. Enhance NCWM as a national and international resource for measurement standards development;
2. Expand the role of NCWM as a resource for state and local weights and measures programs;
3. Promote uniform training for individuals involved in weights and measures;
4. Continue to improve NTEP;
5. Preserve the financial stability of NCWM; and
6. Develop guidance for retaining personnel and succession planning for management positions.

Goal 1: NCWM as a National and International Resource:

Strategy 1 of this goal was initially to implement the Online Position Forum. That was completed in 2011 and the strategy is now to make improvements to the program and promote increased use of it by our membership. Several ideas have been implemented to generate interest. Additionally, guidance has been developed to assist Committees in how to preview and use comments in a consistent manner. New in 2014, comments and positions that are submitted may be viewed immediately instead of being hidden until the comment period ends on June 15. By allowing comments to be viewed immediately, it is hoped that this will stimulate more participation.

The following new strategies were added to this goal in 2013:

Strategy 2: Identify, communicate, and collaborate with other regulatory, industry, and standards development organizations, foreign and domestic, to strengthen awareness of NCWM and draw on mutual resources toward mutual goals.

Strategy 3: Increase consumer group participation in NCWM through outreach efforts.

Goal 2: Expand the Role of NCWM as a Resource to Officials:

NCWM has entered into a contract with a different service provider for press releases that will allow for many more press releases without an increase in costs. This will raise the level of recognition for NCWM and its membership as a resource for expert information in a vast array of topics.

NCWM has conducted a number of surveys in recent years as part of this goal. Several years ago, one was done on budgets, staffing levels, salary grades, and more. These surveys provide good benchmarks, and will be repeated on occasion to identify trends.

Many programs are experiencing severe budget cuts that are diminishing their effectiveness. The AMC has expressed interest in assisting with the development of a “tool kit” that can be used by program administrators to generate awareness and support for their programs. This toolkit will contain materials including data supporting a regulatory presence, industry contacts that can be called upon to explain the necessity of a regulatory presence to ensure a level playing field for businesses and consumer protection, and a short video production.

Goal 3: Promote Uniform Training:

The Professional Certification Program is a top priority under this goal. Two new exams were added in 2012 and several more are in development. Mr. Ross Andersen serves as Certification Exam Coordinator working with the PDC and Subject Matter Experts. Volunteer Subject Matter Experts are needed in the areas of medium and large capacity scales and vehicle tank meters.

There is fast-growing interest among service agencies and regulatory agencies for referencing NCWM Professional Certification as a prerequisite to registering/licensing service agents. This would potentially provide one set of exams to satisfy the testing requirements of many states. Private companies are also very interested in NCWM Professional Certification as a way of instilling confidence in their customers that they are knowledgeable in regulatory standards. See more discussion on this in the PDC report.

NCWM recently worked with Mr. Andersen to ramp up efforts to retain additional Subject Matter Experts so that this program can develop at a faster pace. Anyone interested in assisting the writing and reviewing exam questions should contact NCWM.

There are a number of other strategies under Goal 3. Some recent advancement toward those strategies include a cooperative effort with NIST, whereby NCWM uses grant funds from NIST to fund travel for approved trainers from around the country to assist with NIST training events. A list of those trainers and technical areas that each is comfortable presenting training is now available on the NCWM website. Also, new to the website is a list of training opportunities that have been scheduled. Anyone planning a training event that would like to open up the class to other individuals should contact NCWM to have their event posted.

Goal 4: Continue to Improve NTEP:

NCWM surveyed regulatory officials in 2012 to determine how they access NTEP Certificates of Conformance (CC) in the field. This will be used as a benchmark. As technology advances, NCWM will have a better understanding of how it can make CCs more accessible. In 2013, NCWM added a mobile friendly version of the website that makes it much easier to access the NTEP database using hand-held-devices such as smart phones. It is likely that the 2012 survey will be repeated soon to measure the impact of this and other technology advancements.

A strategy of high priority under this goal is to maintain viable support for NTEP laboratories. Mr. Truex, NTEP Administrator, monitors the number of full-time equivalents associated with the authorized laboratories and tracks evaluation time and backlog statistics to ensure that NTEP evaluations can be completed in a timely manner. He reports these statistics quarterly to the NTEP Committee and Board of Directors.

NCWM has a contingency plan in place to ensure evaluation services are maintained for NTEP applicants in the event that insufficient services are available under the current authorized laboratory system. The Board is monitoring its available resources toward that end to ensure that NCWM is in a position to implement the worst-case scenario, should the need arise. Another strategy toward this goal is the continued development of the Verified Conformity Assessment Program (VCAP), which has already successfully addressed load cells and has moved on to the next device-type category. *See the NTEP Committee Interim Report for more details.*

In 2013, NTEP operated without a field lab for scale evaluations. That, combined with the increasing workload for NTEP staff as a result of VCAP, lead to the hiring of a new NTEP Specialist to assist in both areas. In January 2014, Mr. Darrell Flocken, formerly of Mettler Toledo, LLC was hired in this capacity. This addition to the NCWM family will greatly enhance NTEP's ability to serve its stakeholders.

Goal 5: Preserve Financial Stability:

This goal was originally to “ensure” financial stability. Financial reports of the past several years indicate that NCWM is financially stable barring any unexpected circumstances. However, NCWM must recognize that it does not have sufficient reserves at this time to fully implement the NTEP contingency plan that was developed to ensure continued evaluation services if the authorized state laboratories fell victim to budget cuts. The Board has studied NCWM's needs for reserves for NTEP and other potential exposures. This is being balanced with continued efforts to improve services in support of customers and membership. NCWM finances are reviewed annually.

Goal 6: Develop Guidance for Retaining Personnel and Succession Planning for Management Positions:

This goal was just added in 2014. It will be developed in future strategic planning sessions. It was brought forward out of concern for the high turnover rate of inspection staff in some jurisdictions, cutting of positions in others, and the need for better planning to replace weights and measures administrators.

120-2 I Regional Support**Meeting Documents on Regional Websites:**

In the fall of 2011, NCWM made efforts to be the clearinghouse for all new proposals being submitted to the regional associations. Since then, the process has been streamlined while improving documents, reports, and communication. NCWM provides the regional committees with a report template that contains all of the regions' carryover items and new proposals. The templates are improved each year based on feedback and efforts to streamline the reporting process for everyone.

The report templates in 2013 were modified based on extensive discussions at the 2012 Committee Orientation sessions. Regional committees should find them to be less confusing for presenting the discussions, recommendations, and regional decisions. NEWMA committee chairs expressed that the process is now much easier to work with and also members have a clearer understanding of the issues. Downloading agenda items for Interim and Annual Meetings is made much easier. They also stated that the new format and deadline for Publication 15 works very well.

All of the regional websites are hosted through NCWM. As of 2013, all four regions have now added the e-commerce option for online meeting registrations and membership dues (where applicable) using NCWM's merchant services to process the payments. NCWM provides the administrative services of transferring those funds to the appropriate regional bank accounts and communicating with regional Treasurers regarding the details of those transfers. There is no additional cost to the regions for this added support. The annual fee to NCWM from each region remains at \$200 for unlimited support unless programming is required. In 2014, each of the regions invested \$550 as a one-time cost to program the websites with a mobile version.

Chairman John Gaccione reported at the 99th NCWM Annual Meeting that the regional websites are being used more frequently as a tool for meeting information and meeting registrations.

120-3 I Standing Committees Support**Committee Orientation:**

NCWM conducts Committee Orientation for Committee Chairs and new Committee Members every fall at NIST, OWM in Gaithersburg, Maryland. The location enables full participation by all NIST Technical Advisors. The focus is on leadership, administrative processes, roles and responsibilities, and review of *NCWM Committee Member Handbook*. Additionally, the Committee Chairs and NIST Technical Advisors review agenda items for the new members so they are prepared in advance for the technical discussions and Open Hearings.

Each year additional improvements are made to the *NCWM Committee Member Handbook* and to the report templates that regional Committees use to submit their reports for inclusion in NCWM Publication 15.

Task Groups, Subcommittees, and Steering Committees:

Task Groups (TG), Subcommittees and Steering Committees are created by appointment by the NCWM Chairman. A TG is given a specific charge, and it reports to the appropriate NCWM Standing Committee. A TG will disband at the completion of its assignment. A Subcommittee is charged with ongoing responsibilities in support of a Standing Committee in a specific field of expertise. A Steering Committee is charged with unbiased fact-finding that will assist NCWM membership in decision processes for difficult issues. A Steering Committee will disband upon completion of its specific charge.

NCWM offers resources to these TGs and Subcommittees including meeting space at Interim and Annual Meetings, conference calling and web meeting services, group e-mail services, a dedicated webpage for posting and archiving

documents related to their work, and broadcast e-mail services to reach targeted audiences. Additionally, NIST, OWM has provided Technical Advisors and web meeting forums. All of these tools enable year-around progress of TG and Subcommittee work.

Because NCWM TGs and Subcommittees report directly to NCWM Standing Committees or Board of Directors, any new proposals may appear in NCWM Publication 15 without first being vetted through a regional association. Any such proposals are properly vetted through the Open Hearings of NCWM. This structure enables more efficient standards development.

The Board expresses great appreciation to the volunteers who serve in support of the work of this organization.

Natural Gas Steering Committee:

The Laws and Regulations (L&R) Committee heard spirited debate at the 2013 Interim Meeting Open Hearings on a proposal to recognize the Diesel Gallon Equivalent (DGE) and Diesel Liter Equivalent (DLE) as the method of sale for compressed and liquefied natural gas; similar to the Gasoline Gallon and Liter Equivalents that were recognized in 1994. Opponents argue that a method of sale by mass is preferred.

NCWM Chairman Stephen Benjamin formed a new Natural Gas Steering Committee to address rising issues as the compressed and liquefied natural gas markets rapidly expand. The Steering Committee will report to the L&R Committee. Its charge is to gather information that will assist NCWM Membership in the decision process as model standards are developed for the sale of liquefied and compressed natural gas.

Chair

Mr. Mahesh Albuquerque
CDLE-Oil and Public Safety
Denver, CO
Email: mahesh.albuquerque@state.co.us

Promotional Tool Kit Task Group:

This group will develop tools that may be used by weights and measures agencies to promote awareness and support and adequate funding for their programs. The tools will target three separate audiences;

- Consumers
- Regulated Industries
- Legislators, Governors, and Agency Administrators

Tools may include case studies, data, short-segment video productions, public service announcements, etc.

Chair

Mr. Stephen Benjamin
North Carolina Department of Agriculture
Raleigh, NC
Email: steve.benjamin@ncagr.gov

Weights and Measures Training Manual Task Group:

This new group reports to the PDC and is assigned to develop a training manual that can be used to ensure proper training methods and evaluation of training success for all aspects of field enforcement. Task Group Chairman Michael Cleary presented the PDC a draft of the completed training manual at the 99th NCWM Annual Meeting and confirmed that the work of the TG is now complete. A copy of the draft document was posted to the NCWM website and will be updated to a final copy after review and edits are completed. NCWM expresses gratitude to Mr. Cleary and his TG for quickly completing their charge through volunteer efforts. More information is available in the PDC Report, Item 410-2 – Training.

Chair

Mr. Michael Cleary
Retired
Sacramento, CA
Email: mcleary55@sbcglobal.net

Retail Motor Fuel Dispenser Price Posting and Computer Capability Task Group:

The group reports to the Specifications and Tolerances (S&T) Committee and is developing specifications for multi-tier and discount pricing at retail. For more information, contact:

Chair

Ms. Fran Elson-Houston
Ohio Department of Agriculture
Division of Weights and Measures
8995 East Main Street
Reynoldsburg, OH 43068
Phone: (614) 728-6290
Fax: (614) 728-6290
Email: houston@agri.ohio.gov

Fuels and Lubricants Subcommittee (FALS):

The group reports to the L&R Committee. For more information, contact:

Chair

Dr. Matthew Curran
Florida Department of Agriculture and Consumer Service
3125 Conner Boulevard, Building 2
Mail Stop L@
Tallahassee, FL 32399-1650
Phone: (850) 921-1570
Fax: (850) 921-1548
E-Mail: matthew.curran@freshfromflorida.com

Packaging and Labeling Subcommittee (PALS):

The group reports to the L&R Committee. For more information, contact:

Chair

Mr. Christopher Guay
Procter and Gamble, Co.
One Procter and Gamble Plaza
Cincinnati, OH 45202
Phone: (513) 983-0530
Fax: (513) 983-8984
Email: guay.cb@pg.com

Organometallics Task Group:

The group reports to the FALS and L&R Committee. For more information, contact:

Chair

Mr. Randy Jennings
Tennessee Department of Agriculture
PO Box 40627
Nashville, TN 37204
Phone: (615) 837-5327
Fax: (615) 837-5335
Email: randy.jennings@tn.gov

Multi-Point Calibration Task Group:

The group reports to the S&T Committee. For more information, contact:

Chair

Ms. Julie Quinn
Minnesota Department of Commerce
14305 South Cross Drive, Suite 150
Burnsville, MN 55306
Phone: (651) 539-1555
Fax: (952) 435-4040
Email: julie.quinn@state.mn.us

Moisture Loss Task Group:

The group reports to the L&R Committee. For more information, contact:

Chair

Mr. Kurt Floren
LA County Agricultural Commissioner/Weights and Measures
12300 Lower Azusa Road
Arcadia, CA 91006
Phone: (626) 575-5451
Fax: (626) 350-3243
Email: kfloren@acwm.lacounty.gov

NEWMA reported appreciation from a member that the PALS has been formed as this is an area where weights and measures focus has been sidetracked due to budget issues.

130 FINANCIALS

130-1 I Financial Report

NCWM operates on a fiscal year of October 1 through September 30. Budgets are set to be conservative on projected revenues and realistic on anticipated expenses.

The Board of Directors continues to monitor its ability to fully implement contingency plans based on potential costs compared to reserve funds.

The following is the balance sheet as of June 30, 2014, in comparison with the same time the previous year. Assets in the balance sheet are inflated by the by the NIST Training Initiative Grant, which was awarded to NCWM in 2012. Those funds are earmarked for specific training activities. Assets are also inflated by the Associate Membership Fund. This money is accumulated through the additional \$15 dues paid by NCWM Associate Members, and is spent at the discretion of the AMC in accordance with Committee Bylaws. A significant increase in "Other Current Assets" represents the value of the new NCWM website. It will be depreciated over a period of five years.

ASSETS	June 30, 2014	June 30, 2013
Current Assets	\$	\$
Checking/Savings		
Associate Member Fund	32,998.67	26,602.49
NIST Training Grant	14,860.67	52,253.27
Certificates of Deposit	1,162,359.04	1,149,123.91
Checking	28,119.95	35,697.28
Savings	263,309.23	194,742.49
Total Checking/Savings	\$ 1,501,647.56	\$ 1,458,419.44
Accounts Receivable	995.00	145.78
Other Current Assets	140,066.80	27,165.24
Other Assets	12,322.40	11,889.11
TOTAL ASSETS	\$ 1,655,031.76	\$ 1,497,619.57
LIABILITIES & EQUITY		
Liabilities		
Current Liabilities	\$ 26,795.84	\$ 19,747.93
Total Liabilities	\$ 26,795.84	\$ 19,747.93
Equity		
Designated-Associate Member Fund	32,998.67	
Designated-NIST Training Grant	14,860.67	
Unrestricted Net Assets	1,366,715.87	1,243,897.98
Net Income	213,660.71	233,973.66
Total Equity	\$ 1,628,235.92	\$ 1,477,871.64
TOTAL LIABILITIES & EQUITY	\$ 1,655,031.76	\$1,497,619.57

The following is a graphic view of the past 10 fiscal years based on year-end audit reports. The spike in expenses in 2008 reflects the cost transition from contracted management services to hired employees and procured office space, furniture, computers, etc. The chart shows significant savings in the following years even though NCWM has invested significantly in new initiatives during that time.

A significant investment was made in 2013 to rebuild the NCWM website. Because the website is considered a depreciable asset, the investment does not reduce NCWM's net assets. Expenses in 2014 and going forward will increase with the addition of a new staff person in the National Type Evaluation Program (NTEP). This new staff position is necessary to handle increased workload associated with the Conformity Assessment Program. Mr. Darrell Flocken was hired as the NTEP Specialist, and will greatly enhance NCWM's ability to serve the NTEP stakeholders.

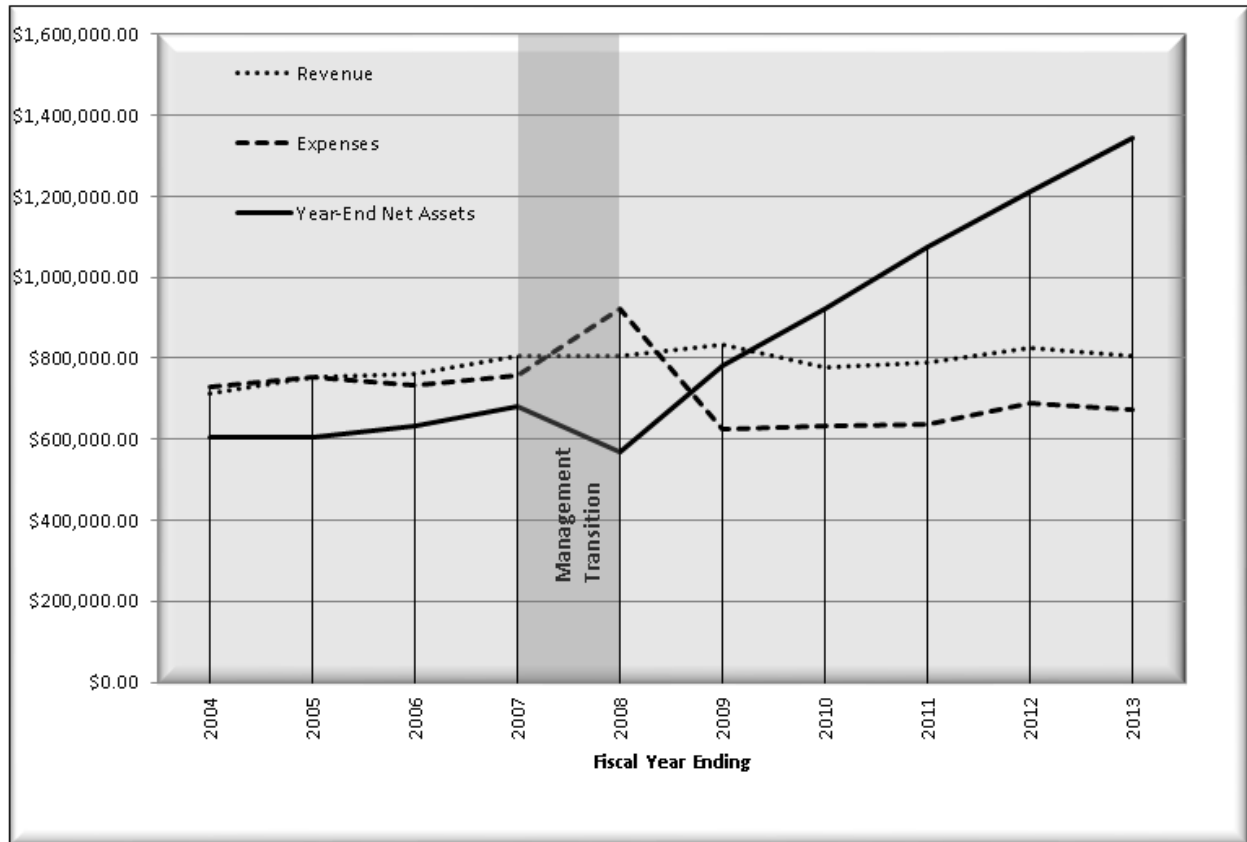

-
- Mr. John Gaccione, Westchester County, New York | Chairman
 - Mr. Ronald Hayes, Missouri | Chairman-Elect
 - Mr. Stephen Benjamin, North Carolina | NTEP Committee Chair
 - Mr. Mark Coyne, City of Brockton, Massachusetts | Treasurer
 - Mr. Jerry Buendel, Washington | Active Membership - Western
 - Mr. Craig VanBuren, Michigan | Active Membership - Central
 - Mr. Mr. Kenneth Ramsburg, Maryland | Active Membership - Southern
 - Mr. James Cassidy, City of Cambridge, Massachusetts | Active Membership - Northeastern
 - Mr. Chris Guay, Procter and Gamble | Associate Membership
 - Mr. Steve Giguere, Maine | At-Large
 - Mr. Mr. Chuck Corr, Archer Daniels Midland Co. | At-Large

- Ms. Carol Hockert, NIST, OWM | Executive Secretary
- Mr. Gilles Vinet, Measurement Canada | Board of Directors Advisor
- Mr. Jim Truex, NCWM | NTEP Administrator
- Mr. Don Onwiler, NCWM | Executive Director

Board of Directors

Appendix A

Report of the Activities of the International Organization of Legal Metrology (OIML) and Regional Legal Metrology Organizations

National Institute of Standards and Technology (NIST), Office of Weights and Measures (OWM)

INTRODUCTION

The NIST, OWM is responsible for coordinating U.S. participation in OIML and other international legal metrology organizations. Learn more about OIML at www.oiml.org and about NIST, OWM at www.nist.gov/owm. Dr. Charles Ehrlich, Program Leader of the International Legal Metrology Program, can be contacted at (301) 975-4834, by fax at (301) 975-8091, or charles.ehrlich@nist.gov.

Note: OIML publications are available without cost at www.oiml.org.

Table A Table of Contents

INTRODUCTION	1
TC 3/SC 5 Conformity Assessment (United States)	3
TC 5/SC 1 Environmental Conditions (Netherlands)	3
TC 5/SC 2 Software (Germany and BIML)	4
TC 6 Prepackaged Products (South Africa)	4
TC 8 Measurement of Quantities of Fluids (Japan)	4
TC 8/SC 1 Static Volume and Mass Measurement (Germany)	5
TC 8/SC 3 Dynamic Volume and Mass Measurement for Liquids Other Than Water (United States and Germany)	5
TC 8/SC 5 Water Meters (United Kingdom)	5
TC 8/SC 6 Measurement of Cryogenic Liquids (United States)	5
TC 8/SC 7 Gas Metering (Netherlands)	5
TC 9 Instruments for Measuring Mass (United States)	6
TC 9/SC 2 Automatic Weighing Instruments (United Kingdom)	6
TC 17/SC 1 Humidity (China and United States)	6
TC 17/SC 8 Quality Analysis of Agricultural Products (Australia)	6
OIML Mutual Acceptance Arrangement (MAA)	7

Table B
Glossary of Acronyms and Terms

Acronym	Term	Acronym	Term
ANSI	American National Standards Institute	ISO	International Standardization Organization
APEC	Asia-Pacific Economic Cooperation	IWG	International Work Group
APLMF	Asia-Pacific Legal Metrology Forum	LMWG	Legal Metrology Work Group
APMP	Asia-Pacific Metrology Program	MAA	Mutual Acceptance Agreement
B	Basic Publication	MTL	Manufacturers' Testing Laboratory
BIML	International Bureau of Legal Metrology	NIST	National Institute of Standards and Technology
BIPM	International Bureau of Weights and Measures	NTEP	National Type Evaluation Program
CD	Committee Draft ¹	OIML	International Organization of Legal Metrology
CIML	International Committee of Legal Metrology	OWM	Office of Weights and Measures
CTT	Conformity to Type	PG	Project Group
D	Document	R	Recommendation
DD	Draft Document ²	SC	Technical Subcommittee
DoMC	Declaration of Mutual Confidence	SIM	Inter-American Metrology System
DR	Draft Recommendation ²	TC	Technical Committee
DV	Draft Vocabulary ³	USNWG	U.S. National Work Group
GA	General Assembly	VIM	International Vocabulary of Metrology
IEC	International Electrotechnical Commission	VIML	International Vocabulary of Legal Metrology
IQ Mark	International Quantity Mark	WD	Working Draft ³

¹ CD: a draft at the stage of development within a technical committee or subcommittee; in this document, successive drafts are numbered 1 CD, 2 CD, etc.

² DD, DR, and DV: a draft document approved at the level of the technical committee or subcommittee concerned and sent to BIML for approval by CIML.

³WD: precedes the development of a CD; in this document, successive drafts are number 1 WD, 2 WD, etc.

**Details of All Items
(In order by Reference Key)**

I. REPORT ON THE ACTIVITIES OF THE OIML TECHNICAL COMMITTEES

This section reports on recent activities and the status of work in the OIML Technical Committees (TCs), Technical Subcommittees (SCs), and Project Groups (PGs) of specific interest to members of the National Conference on Weights and Measures (NCWM). Schedules of future activities of the TC/SC Secretariats, PG Conveners, the U.S. National Work Groups (USNWGs), and the International Work Groups (IWGs) and Project Groups of the TCs and SCs are also included.

TC 3/SC 5 Conformity Assessment (United States)

The OIML Basic Publications B 3:2011, *Certificate System*, and B 10:2012, *Mutual Acceptance Arrangement (MAA)*, are the core documents underpinning the OIML Certificate System. An amendment to B 10 was approved by the CIML that allows for the voluntary use of test data from manufacturer's test laboratories (MTLs) under specially supervised conditions (NCWM has adopted the position that it will not accept test data under the MAA that was obtained from MTLs). An MAA workshop was held in conjunction with the 2013 CIML Meeting (in Vietnam) to gather experiences of the various MAA stakeholders in the MAA. Based on the outcome of this workshop and MAA discussions at the 2013 CIML Meeting, OIML has established an *Ad-Hoc* Working Group (WG) consisting of interested CIML members, Committee on Participation Review (CPR) members, and representatives of manufacturers' associations. This WG is tasked with reviewing the structure, rules, and procedures governing the operation of the MAA (and the role of Utilizing Participants), with a view to increasing the efficiency of the operation of the MAA, and, if necessary, amending their internal (MAA) documents and suggesting to TC 3/SC 5 appropriate amendments to OIML Publication B 10. This *Ad-Hoc* WG is chaired by the CIML first Vice-President Dr. Roman Schwartz of Physikalisch-Technische Bundesanstalt (PTB) (Germany), and held its first meeting on March 20 - 21, 2014, at NIST. Mr. Darrell Flocken from NCWM attended, as did Mr. Rob Upright, President of the U.S. Scale Manufacturer's Association (SMA), and Mr. Dmitri Karimov, President of the U.S. Meter Manufacturer's Association (MMA). Three Task Groups (TGs) were established that are looking into 1) improving the international awareness and use of the OIML MAA, 2) developing a more robust model for operation of the CPR, and 3) evaluating the impact that termination of the Basic System for categories already covered by the MAA (load cells, NAWIs, and water meters) would have on all stakeholders. Reports from these three TGs will be presented at the 2014 CIML Meeting in November 2014, in Auckland, New Zealand.

The 2 CD of a new OIML document entitled *The Role of Measurement Uncertainty in Conformity Assessment Decisions in Legal Metrology* has been developed by the Secretariat (Dr. Charles Ehrlich). For a copy of this document, please contact Dr. Ehrlich at (301) 975-4834 or charles.ehrlich@nist.gov. Comments were submitted to the Secretariat by June 30, 2014. Please see the MAA section in the National Type Evaluation Program (NTEP) Committee Report of this publication for more details on the activities of TC 3/SC 5. Please contact Dr. Ehrlich for more information on the activities of this Subcommittee.

TC 5/SC 1 Environmental Conditions (Netherlands)

OIML D 11 *General requirements for measuring instruments - Environmental conditions* was approved by the CIML in October 2013, and was published in December 2013. This is a very important document in the OIML system and is used by all of the OIML TCs as a general reference for technical and testing requirements on all measuring instruments. Highlights of this recent revision cycle include: expanding the terminology section, updating several testing sections to reflect the latest International Electrotechnical Commission (IEC) reference standards, and including a new environmental class (E3) for a non-mains local source of electrical power supply. Please contact Mr. Ralph Richter at (301) 975-3997 or ralph.richter@nist.gov, if you would like further information on TC 5/SC 1 or OIML D 11.

TC 5/SC 2 Software (Germany and BIML)

The OIML D 31, *General Requirements for Software-controlled Measuring Instruments*, has been published, and it will serve as guidance for software requirements in International Recommendations by OIML TCs. The United States participated in the technical work on this document and submitted votes and comments on several drafts of the document. A new project on software verification was approved by CIML, and the United States is waiting for the first draft of this document. Please contact Dr. Ambler Thompson at (301) 975-2333 or ambler@nist.gov if you would like to discuss OIML software efforts.

TC 6 Prepackaged Products (South Africa)

After an online CIML vote was conducted, it was decided that the TC 6 project to develop an OIML International Quantity Mark (IQ Mark) would be terminated. The United States had already voted in favor of terminating this project, on the grounds that the effort to manage and certify quality control systems would have added unnecessary extra costs, with no value added, to all participating suppliers. At the same time, another CIML vote was conducted on a proposal for a new TC 6 project, *Guidance for defining the system requirements for a certification system for prepackages*. The United States voted against this proposal, on the grounds that even such an OIML guidance document could be construed as endorsing an OIML IQ Mark program. At the CIML meeting in October 2013, it was decided to move forward with the drafting of this publication.

Besides the IQ Mark project, two other important projects are under discussion in TC 6: a revision of OIML Recommendation (R) 87 *Quantity of Product in Prepackages* (the OIML equivalent to NIST Handbook 133, *Checking the Net Contents of Packaged Goods*) and a revision of OIML R 79 *Labeling Requirements for Prepackaged Products*. The NIST Statistical Engineering Division has been participating in a small *ad-hoc* WG to improve the statistics in R 87. A 1 CD of R 87 has been developed and circulated for comment by the Secretariat. The draft contained proposed revisions that NIST OWM believes is unnecessarily complex and, therefore, subject to easy misinterpretation, and another that appeared to go beyond the scope of package labeling requirements. After consulting with the Chairman of the NCWM Packaging and Labeling Subcommittee about the proposed revisions to both R 87 and R 79, the United States voted “no” on R 79 (votes are not taken on 1 CDs, so only comments were submitted on R 87). The main reason for opposing both drafts is they include proposed definitions for prepackage, packaging material, and product that are likely to result in confusion for consumers and packers alike. A meeting of TC 6 was held in Switzerland in September 2013.

The Secretariat has now distributed a 4 CD of R 79; it was revised to eliminate one of the definitions, which contained language, that we and other TC 6 members believed were confusing. The United States voted “yes” on the 4th CD and submitted some additional suggestions to clarify the language regarding references to CODEX labeling requirements for drained weight. The next meeting of TC 6 will be in September 2014 in South Korea.

For more information on the activities of this Committee, and to participate in the U.S. review of these CDs, please contact Mr. Ken Butcher at (301) 975-4859 or kbutcher@nist.gov.

TC 8 Measurement of Quantities of Fluids (Japan)

The CIML has approved projects to revise the following TC 8 documents: R 63, *Petroleum Measurement Tables* (1994), and R 119, *Pipe Provers for Testing of Measuring Systems for Liquids Other Than Water* (1996). Both of these documents are important for other OIML recommendations involving liquid measurement. Please contact Mr. Ralph Richter at (301) 975-3997 or ralph.richter@nist.gov, if you would like copies of the documents or to participate in any of these projects.

TC 8/SC 1 Static Volume and Mass Measurement (Germany)

The United States chairs the Project Group that is drafting new sections of OIML R 71, *Fixed Storage Tanks*, and R 85, *Automatic Level Gages for Measuring the Level of Liquid in Fixed Storage Tanks*, to add specific requirements for specialized tanks. OIML R 80-2, *Road and Rail Tankers, Test Methods*, is being developed by Germany. A meeting of TC 8/SC 1 has been proposed for December 2014 in Germany. Please contact Mr. Ralph Richter at (301) 975-3997 or ralph.richter@nist.gov, if you would like copies of the documents or to participate in any of these projects.

TC 8/SC 3 Dynamic Volume and Mass Measurement for Liquids Other Than Water (United States and Germany)

New annexes for measuring systems for foaming potable liquids, for pipelines, and for aircraft refueling have been added to OIML R 117-2, *Dynamic Measuring Systems for Liquids Other Than Water, Part 2, Test Methods*. A meeting of the R 117 International Project Group was held in October 2013 in Teddington (London), United Kingdom and was hosted by the UK National Measurement Office. Representatives of major manufacturers of these systems and liaison organizations actively participated in the meeting. These technical experts provided a depth of experience and technical expertise that proved highly valuable during the meeting. The 2 CD of R 117-2 was distributed late in December 2013; it was approved by the Project Group with over 300 comments. The 1 CD of R 117-3 *Part 3, Test Report Format* was distributed in March 2014. A meeting of the R 117 International Project Group was held in April 2014 in Chicago to discuss international comments on the 2 CD of R 117-2 and the 1 CD of R 117-3. If you have any questions or would like to participate in the next phases of this project, please contact Mr. Ralph Richter at (301) 975-3997 or ralph.richter@nist.gov.

TC 8/SC 5 Water Meters (United Kingdom)

OIML, the International Standardization Organization (ISO), and the European Committee for Standardization (CEN) have worked together to harmonize requirements for water meters using OIML R 49 *Water Meters Intended for the Metering of Cold Potable Water and Hot Water Parts 1, 2, and 3* as the base document. The United States submitted comments on the 3 CD of the harmonized document in September 2012 and participated in a meeting of the Joint Working Group of these three organizations in London, England, in October 2012. The American Water Works Association Committee on Water Meters is assisting in these efforts. The DR of R 49 passed its CIML preliminary ballot in May 2013, and R 49 received final CIML approval in October 2013. R 49 published in early 2014. Please contact Mr. Ralph Richter at (301) 975-3997 or ralph.richter@nist.gov, if you would like additional information on this effort.

TC 8/SC 6 Measurement of Cryogenic Liquids (United States)

In May 2013, the Secretariat for R 81, *Dynamic Measuring Devices and Systems for Cryogenic Liquids* distributed a first working draft (1 WD) of R 81 to TC 8/SC 6 and the USNWG for their review and comment. Nine members of the R 81 project group submitted comments on Parts 1 and 2 of R 81 by the September 2013 deadline. To obtain more information or to participate in this project, please contact Ms. Juana Williams at (301) 975-3989 or juana.williams@nist.gov.

TC 8/SC 7 Gas Metering (Netherlands)

OIML R 137-1 and R 137-2, *Gas Meters; Part 1: Metrological and Technical Requirements* and *Part 2: Metrological Controls and Performance Tests* were published in 2012. Extensive U.S. comments on the 1 CD, the 2 CD, and the DR were developed in cooperation with the measurement committees of the American Gas Association. CIML voting on the preliminary ballot of R 137-3 *Part 3: Report Format for Type Evaluation* closed in March 2014 and is expected to have final approval in November 2014. The OIML R 137 document is especially important to the U.S. interests because the American National Standards Institute (ANSI) B 109 committee on gas measurement is using the published R 137 to create a new performance-based standard for gas meters in the United

States. Please contact Mr. Ralph Richter at (301) 975-3997 or ralph.richter@nist.gov, if you would like to participate in these efforts or if you would like to obtain a copy of any of these gas measurement documents.

The CIML preliminary ballot on OIML R 139, *Compressed gaseous fuel measuring systems for vehicles*, closed in March 2014. This standard is important to U.S. stakeholders, especially in the effort to maximize harmonization between domestic and international legal metrology requirements used for the delivery of alternative fuels such as hydrogen gas and compressed natural gas (CNG). The United States voted “yes” and submitted comments on the preliminary ballot of R 139, and final approval is expected in November 2014. To obtain more information or to participate in this project, please contact Ms. Juana Williams at (301) 975-3989 or juana.williams@nist.gov.

TC 9 Instruments for Measuring Mass (United States)

The revision of OIML R 60 *Metrological Regulation for Load Cells* is planned to cover everything from the basic principles of R 60 (e.g., tolerances and accuracy classes) to exploring the addition of new requirements. The United States distributed the 2 CD of R 60 Parts 1 and 2 (*Metrological and technical requirements and Metrological controls and performance tests*) in June 2013. International Project Group (PG) members were asked to review this 2 CD for vote and comment. The majority of voting responses were negative indicating that the draft needed to be further developed by the Project Group. A meeting of TC 9/P 1 was held at NIST in Gaithersburg, Maryland, on March 17 - 18, 2014 to discuss unresolved issues regarding the R 60 revision. This meeting was one of three OIML meetings held that week, meetings of the CPR and MAA *Ad Hoc* WG (see section on TC 3/SC 5) were also convened. Input from the TC 9/P 1 meeting and comments received pertaining to the 2 CD of R 60 will be incorporated into a 3 CD that is expected to be circulated in July 2014. For more information on TC 9 activities, please contact Mr. John Barton at (301) 975-4002 or john.barton@nist.gov.

TC 9/SC 2 Automatic Weighing Instruments (United Kingdom)

The DR of OIML R 106, Part 1, *Automatic Rail Weighbridges*, was published in 2012. The DR of R 106-2 was approved by the CIML in 2012 and subsequently published in 2013.

All three parts of OIML R 50, *Continuous Totalizing Automatic Weighing Instruments* (Belt Weighers), have been forwarded to the BIML, and it is expected that they will receive final CIML approval in November 2014. Parts 1 and 2 (technical/metrological requirements and test procedures) were approved in the 2013 CIML preliminary ballot and the FDRs (Final Draft Recommendation) are currently under preparation. The 2 CD of R_50-3 was approved in the TC 9/SC 2 ballot in September 2013 and was sent to the BIML in March 2014. To receive copies of these documents or to obtain more information on the work of this Subcommittee, please contact Mr. John Barton at (301) 975-4002 or john.barton@nist.gov.

TC 17/SC 1 Humidity (China and United States)

The 6 CD of OIML R 59, *Moisture Meters for Cereal Grains and Oilseeds*, was distributed in March 2013, and it was requested that comments be returned in June 2013. Meetings of TC 17/SC 1 and TC 17/SC 8 were held at NIST in Gaithersburg in July 2013 to discuss these returned comments and to develop the next draft. The 7 CD will be distributed for a vote later this year. Please contact Ms. G. Diane Lee at (301) 975-4405 or diane.lee@nist.gov if you would like to participate in this IWG.

TC 17/SC 8 Quality Analysis of Agricultural Products (Australia)

Meetings of TC 17/SC 1 and TC 17/SC 8 were held at NIST in Gaithersburg, Maryland, in July 2013 to discuss international comments received on the 4 CD of a draft document *Measuring Instruments for Protein Determination in Grains*. Australia plans to soon distribute a 5 CD of this draft document for a vote. Please contact Ms. G. Diane Lee at (301) 975-4405 or diane.lee@nist.gov, if you would like to participate in this IWG.

OIML Mutual Acceptance Arrangement (MAA)

The report on the OIML MAA can be found in the NTEP section of this document. For further information on the MAA and its implementation, please contact Dr. Charles Ehrlich at (301) 975-4834 or e-mail charles.ehrlich@nist.gov.

II. REPORT ON THE 48th CIML MEETING IN HO CHI MINH CITY, VIETNAM IN OCTOBER 2013

Mr. Peter Mason, CIML member from the United Kingdom and President of the CIML, opened the meeting and gave the President's Report.

Mr. Stephen Patoray, who has been serving as BIML Director since January 2011 provided several reports on financial and administrative matters at the BIML, including improvements that have been implemented since his arrival at the BIML. After consideration of an external auditor's review, the CIML approved the 2012 accounts and instructed its President to present them to the 15th OIML Conference.

The CIML elected Dr. Yukinobu Miki, the CIML Member for Japan, as second Vice-President for a six-year term; the Committee also decided to renew the contract of Mr. Ian Dunmill, BIML Assistant Director, for a five-year term starting in March 2014.

The CIML welcomed Colombia as a new Member State and Zambia as a re-instated Member State. The CIML also welcomed Iraq, Uganda, and Yemen as new Corresponding Members – and Guinea, Korea (DPR), and Rwanda as re-instated Corresponding Members.

The Committee, noting the report given by the BIML on its activities pertaining to developing country matters, recognized the importance of coordinating the various projects and initiatives promoted by the OIML, individual Member States and Corresponding Members, and other bodies with an interest in promoting the economic development of countries and economies with emerging metrology systems. The CIML decided to set up an advisory group to help carry out wide consultation, to seek additional suggestions, and to build up links with other bodies which have a contribution to make in the area of developing countries.

The BIML reported on the implementation of OIML B 6-1:2012 Directives for OIML technical work. The CIML approved a fairly minor revision to B 6-1, but decided to postpone further work on B 6 until sometime in the future.

The CIML approved the following draft publications:

- OIML V 1, *International vocabulary of terms in legal metrology (VIML)*;
- OIML R 46-3, *Active electrical energy meters – Part 3: Test report format*;
- OIML R 49, *Water meters for cold potable water and hot water – Part 1: Metrological and technical requirements, Part 2: Test methods, and Part 3: Test report format*;
- New OIML Recommendation *Instruments for continuous measuring CO and NOx in stationary source emissions*;
- OIML D 11, *General requirements for measuring instruments – Environmental conditions*; and
- OIML B 14, *Procedure for the election of the CIML President and Vice-Presidents*.

The CIML confirmed its decision to start as a new project in TC 4, Measurement standards and calibration and verification devices, the revision of OIML D 8:2004, *Measurement standards. Choice, recognition, use, conservation, and documentation*.

The CIML also confirmed its decision to start as a new project in TC 6, Prepackaged products, the drafting of a new publication *Guidance for defining the system requirements for a certification system for prepackages*, noting the reservations about this effort expressed by several of the Member States (including the United States).

Noting the oral report on the outcome of the seminar to review the operation of the OIML Mutual Acceptance Arrangement (MAA) that was given by the CIML first Vice-President, Dr. Roman Schwartz of PTB (Germany), the CIML decided that there is a need to raise awareness of the MAA system among those not currently using it, in particular among potential Utilizing Participants. The CIML urged its Members, the participants in the MAA, and the BIML to actively promote the MAA among legal metrology authorities and measuring instrument manufacturers worldwide. The CIML encouraged its Members to draw to the attention of trade negotiators within their countries the opportunities which OIML Recommendations and the MAA structures offer as means of reducing barriers to trade and the possibility they provide to enhance both bilateral and multilateral trade negotiations.

The CIML instructed the BIML, in its capacity as secretariat of the MAA Committees on Participation Review (CPR), to set up an *ad-hoc* WG consisting of interested CIML and/or CPR members and representatives of manufacturers' associations to consider how this awareness can be raised, and to provide secretarial support to this WG. The *ad-hoc* WG was also tasked with reviewing the CPRs and their structure, the rules and procedures governing the operation of the MAA, and the role of Utilizing Participants, with a view to increasing the efficiency of the operation of the MAA. Dr. Roman Schwartz will chair this *ad-hoc* WG and report on its activities to the 49th CIML Meeting. (See also the TC 3/SC 5 section of this OIML report.)

III. FUTURE OIML MEETINGS

The CIML accepted the invitation of New Zealand to host the 49th CIML Meeting in Auckland, New Zealand, in November 2014.

The next OIML Conference will be held in 2016; the venue and dates for this Conference will be decided by the CIML at a future date.

V. REGIONAL LEGAL METROLOGY ORGANIZATIONS

A meeting of the Inter-American Metrology System (SIM) General Assembly is organized annually and is the event where delegates from National Metrology Institutes of the Americas meet to discuss important issues. This past year, the SIM General Assembly was held in Santiago de Queretaro, Mexico, in October 2013. Mr. Jose Dajes Castro, from INDECOPI in Lima, Peru, serves as the SIM President. The Legal Metrology Working Group is chaired by Mr. Emilio Löbbe from INTI/Argentina. The organization is working to build capacity in legal metrology for SIM member countries. Please contact Mr. Ralph Richter at (301) 975-3997 or ralph.richter@nist.gov for more information on SIM.

The 20th Meeting of the Asia Pacific Legal Metrology Forum (APLMF) was held November 5 - 8, 2013, in Yogyakarta, Indonesia. Sixteen APLMF Member Economies participated in this meeting. The People's Republic of China holds the Presidency and Secretariat of APLMF. Mr. Changcheng, APLMF President and Vice Minister of AQSIQ, chaired the meeting. APLMF activities are facilitated through its seven work groups.

The main objectives of APLMF are to coordinate regional training courses in legal metrology and to provide a forum for exchange of information among legal metrology authorities. Changes in APEC priorities are making it more difficult to achieve funding. While feedback from the previously-held training courses has been positive, it is becoming clear that in order to continue to receive funding for the training, APLMF needs to do a more thorough job of assessing and documenting the impact of the training courses on the economies that receive the training.

The most active WG is on Training Coordination, chaired by Australia. Training on "Smart Electricity Meters" was held in June 2013 in Bandung, Indonesia. Eighty students from APLMF member economies participated in this training. In November 2013, a course on "Traceability in Rice Moisture Measurement" was held in Chiang Mai, Thailand.

The WG on Training Coordination reported on the results of a 2013 survey of APLMF member economies that requested information on the benefits of APLMF training that was conducted in the period 2005 to 2013. Clearly, the results indicated that the more than 20 courses conducted by APLMF in that 8-year time period were highly

Appendix A – Report on the Activities of OIML and Regional Legal Metrology Organizations

valued by the member economies, promoted harmonization in the Asia-Pacific region, and frequently led to revised/improved legislation and regulations in the member economies.

Also discussed at the APLMF meeting was a planned PTB project to work with APLMF and APMP to promote/improve the metrological systems of developing economies in Asia. This project is still in the early-development stages, so much of the discussion at the APLMF meeting focused on selecting and prioritizing possible objectives of this project. If the project is approved and funded by the German ministry, it is possible that some of these funds could be used by APLMF to conduct future training.

The United States was represented at the APLMF meeting in Yogyakarta, Indonesia, by Mr. Ralph Richter, who served as acting-chair (for Dr. Charles Ehrlich) of the APLMF WG on MRAs. Mr. Richter gave a report and update on the OIML MAA (including the MAA seminar that was held in October 2013 in Vietnam) and presented the United States Country Report.

The 2014 APLMF meeting will be held in November 2014 in Wellington, New Zealand. Please contact Mr. Ralph Richter at (301) 975-3997 or ralph.richter@nist.gov for more information on APLMF.

THIS PAGE INTENTIONALLY LEFT BLANK

Appendix B

**Associate Membership Committee (AMC)
Agenda and Draft Meeting Minutes**

Paul Lewis, Chair
Rice Lake Weighing Systems

**Table A
Table of Contents**

Title of Content	Page
AGENDA.....	1
AMC DRAFT MEETING MINUTES	3
Call to Order	3
Meeting Minutes	3
Financial Condition.....	3
Board of Directors Report.....	3
Professional Development Committee (PDC) Report	5
Laws and Regulations (L&R) Committee Report.....	5
AMC Fund Disbursement Report	5
Filling Vacant Positions	5
Old Business	5
New Business	5
Adjournment	6
Individuals in Attendance	6

Details of All Items
(In order by Reference Key)

I. Agenda

- I. Call to Order
 - II. Approval of Meeting Minutes
 - III. Financial Condition
 - IV. NCWM Industry Representative Reports
 - (a) Board of Directors Report
 - (b) Professional Development Committee Report
 - (c) Laws and Regulations Committee Report
 - V. AMC Fund Disbursement Requests
 - VI. Filling Vacant Positions
 - VII. Old Business
 - VIII. New Business
 - IX. Adjournment
-

THIS PAGE INTENTIONALLY LEFT BLANK

Associate Membership Committee Draft Meeting Minutes

July 15, 2014
Detroit, Michigan

I. Call to Order

Chairman Paul Lewis called the meeting to order at 5:00 p.m.

II. Meeting Minutes

A copy of the updated 2014 Interim Meeting Minutes was distributed. The minutes were reviewed, updates were made, and a motion was made by Mr. Grabski and seconded by Mr. Calix to approve the minutes with corrections. With no further discussion the minutes were approved.

III. Financial Condition

A copy of the financial report was distributed; Chairman Paul Lewis reports that the AMC fund has a balance of \$32,998.67 as of July 11, 2014.

Mr. Calix made a motion to accept the financial report. Mr. Grabski seconds the motion, with no further discussion the financial report was approved.

IV. NCWM Industry Representative Reports

a. Board of Directors Report

CWMA

- CWMA Interim: September 8 - 11, St Charles
- CWMA Annual: May 18 -21, Columbus, Ohio

NEWMA

- Interim: October 15 – 16, Connecticut
- Annual: May 4 – 8, Saratoga, New York

SWMA

- Annual Meeting: October 5 - 8, Raleigh, North Carolina (starting Sunday morning)

WWMA

- Annual Meeting: September 14 - 18, Portland, Oregon
- Alaska getting new lab accredited and ready to operate
- Boise, Idaho, for 2015 and Hawaii for 2016

NIST

- Mr. Clark Cooney new to NIST
- NIST planning to do half day trainings in conjunction with regional meetings

- OIML 117 Dynamic Measuring for Liquids other than water – moving fast and vote at CIML meeting in November. Likely pass and NTEP needs to think about MAA.

Measurement Canada

- Effective August first, new mandatory inspections of weights and measures devices on regular schedule. Done by private, accredited third parties. Previously inspected 2 % to 4 % per year, Measurement Canada will be monitoring data for performance. Like a lab test in the marketplace.

Budget

- Tracking at about 10 % Gain Membership

Membership

- Currently 2211 NCWM members
- 258 people have registered for this meeting, last year 198 people.
- 41 states present at this meeting.
- Next year is Philadelphia and 100th NCWM Meeting.
 - Welcome Gifts (tote bags, notebook cover, pens, DVDs) for attendees.
 - Raise registration fee to \$350.00 for this meeting and future meetings.
 - Two door prizes – Scale and Gas pump (purchased for meeting).
 - Keynote Speaker: N. David Smith likely – big name speakers have big costs.
 - Luncheon for 100th Anniversary.
 - Outing at Franklin Institute.
 - 100th Anniversary pin and promoting pins again.
 - What would AMC be willing to help with at the 100th Meeting?

Bylaws

- Concern about whether Voting Items downgraded by Committee being upgraded by the voting membership.
- Separate an item from the report? Don't like the report being held hostage.
- Role of Subcommittee vs Committee.
- Chuck Corr to lead look at Policies and Bylaws on items, voting, and reports.

Professional Certification

- Close to finalizing three sections
 - Large Capacity Scales;
 - Medium Capacity Scales; and
 - Vehicle Tank Meters.
- Two more will be developed (Price Verification and LP Gas).
- Toolkit – no activity has occurred but group continues to work.

On-line Forum

- Changes made to make it more useful, but usage was down significantly, should we discontinue?
- Only four comments.

b. Professional Development Committee (PDC) Report

- The task group has completed the first three training exam modules. They are retail motor fuel dispensers, basic package checking, and small capacity scales Class III.
- The working group has created a template for a complete field training program. This was distributed to the states. There has been very little comment to date.
- The next three modules to be completed are VTM, Medium Capacity Scales, and Large Capacity Scales.
- The PDC would like to know if industry plans to use the modules in their own field training programs.
- The PDC is interested in promoting the use of AMC training funds to states or jurisdictions interested in setting up field training programs. Mr. Michael Cleary is willing to conduct training if requested. There is also discussion about developing a video on setting up these programs.

c. Laws and Regulations (L&R) Committee Report

- Mr. Grabski reports that the Committee finished their meetings everything will be published in NCWM Publication 16.
- All items keep their public status for voting, withdraw informational or developing.
- Most of the discussion was around GGE and DLE and fuel filters.

V. Associate Membership Committee (AMC) Fund Disbursement Report

- New York State Weights and Measures Association (\$2,500) (Paid) – State sent in a letter of appreciation.
- Michigan (\$1000) for room rental request was approved in May. – Committee approved through e-mail.
- Arkansas Bureau of Standards (\$2,500) – Request was sent in on the wrong form. The request was approved pending update on the correct form.
 - Arkansas request will be used for a package checking milk, eggs, and chicken. NIST Handbook 133, *Checking the Net Content of Packaged Goods*, August 11 – 14, 2014.
 - The State of Arkansas will give left over products to the local food pantry.
 - Mr. Lewis asked the state to overestimate the charges so if the request is not for a sufficient amount another request will not need to be made.
 - An itemized list will be provided to the Committee of the items purchased.

VI. Filling Vacant Positions

- Mr. Bill Callaway with Crompco was elected to Chair.
- Mr. David Calix with NCR was elected to the Vice Chair.
- Mr. Richard Shipman with Rice Lake Weighing System elected to Secretary Treasurer.
- Mr. Paul Lewis with Rice Lake Weighing System was elected to another term on the Committee.

VII. Old Business

- No update on Toolbox.
- Funds for the 100th annual meeting, no request have been requested.

VIII. New Business

- Mrs. Juroch asks if the AMC could help provide coffee for the Conference. The NCWM will not accept funds.

- Mr. Langford asks that we go to the BOD and ask them to rescind the membership funds. Since the money is not being used.
- Mr. Guay states the issues of funds not being used was brought up to the BOD before.
- Mr. Murnane states, if we don't see major increase in funds use, then we want to rescind to the Conference.
- Mr. Murnane stated, we should vote on decreasing the funds.
- Mr. Lewis states that a few years ago we spoke about increasing the amount.
- Mr. Guay states that we could recommend that we eliminate the \$15 fee.
- Mr. Calix states we should let the funds build, the PDC is going to push for training for the testing.
- Mr. Murnane asks Mr. Guay take it to the Board. We need states to request funds or we will end the program.
- Mr. Grabski agrees with Mr. Calix that we need to be patient on fund requests.
- Mr. Vires states, it may be too much regulation on the funds, that is stopping the states from requesting the funds. Mr. Vires asks what about a survey, let's survey the states.
- Maybe the PDC should present how easy it is to request the funds.
- Mr. Langford made a motion to ask Mr. Guay to go to the Board to stress the importance of the usage of membership funds. If the funds are not used, then the AMC will rescind. Motion was seconded and approved.
- Mr. Calix recommends that the AMC sponsor training in a difficult area.
- Mr. Calix mentioned that we should consider having a Conference call regarding any updates items that we are working on.
- It was agreed that Mr. Calix will submit three month sync up meeting.

IX. Adjournment

With no further new business Chair Lewis adjourned the meeting at 6:30 p.m.

Respectfully submitted by,
Mr. David Calix
Secretary, AMC

Individuals in Attendance

Mr. David Calix – NCR
Mr. Bill Callaway- Crompco
Mr. Ron Gibson – Seraphin
Mr. Steve Grabski – Walmart
Mr. Chris Guay – Procter & Gamble
Mrs. Carrie Haler – Pier 1 Imports
Mrs. Krister Hard – AF Segerstad – IKEA
Mr. Jon Heinlein – Transcell
Mr. Jim Hewston – J.A. King
Mr. John Hughes – Rice Lake Weighing systems
Mrs. Zina Juroch – Pier 1 Imports
Mr. Stephen Langford – Cardinal Scale MFG
Mr. Paul Lewis – Rice Lake Weighing Systems
Mr. Robert Murnane – Seraphin
Mr. Henry Oppermann – W&M Consulting
Mr. Richard Shipment – Rice Lake Weighing System
Mrs. Erica Steinlein – Trader Joes
Mr. Louis Straub – Fairbank Scales
Mr. Rob Underwood – PMAA
Mr. Rob Upright – Vishay Transducers
Mr. Russell Vires – Mettler-Toledo

Report of the Laws and Regulations (L&R) Committee

Raymond Johnson, Committee Chair
New Mexico

200 INTRODUCTION

This is the report of the Laws and Regulations Committee (hereinafter referred to as the “Committee”) for the 99th Annual Meeting of the National Conference on Weights and Measures (NCWM). This report is based on the Interim Report offered in the NCWM Publication 16, “Committee Reports,” testimony at public hearings, comments received from the regional weights and measures associations and other parties, the NCWM 2014 Online Position Forum, the addendum sheets issued at the Annual Meeting, and actions taken by the membership at the voting session of the Annual Meeting. The voting items shown below were adopted as presented when this report was approved. This report contains those recommendations to amend National Institute of Standards and Technology (NIST) Handbook 130 (2014), “Uniform Laws and Regulations in the Areas of Legal Metrology and Engine Fuel Quality,” or NIST Handbook 133 (2014), “Checking the Net Contents of Packaged Goods,” Fourth Edition.

Table A identifies the agenda items and appendix items. The agenda items in the Report are identified by Reference Key Number, title, page number and the appendices by appendix designations. The acronyms for organizations and technical terms used throughout the agenda are identified in Table C. The first three digits of the Reference Key Numbers of the items are assigned from The Subject Series List. The status of each item contained in the report is designated as one of the following: **(D) Developing Item:** the Committee determined the item has merit; however, the item was returned to the submitter or other designated party for further development before any action can be taken at the national level; **Informational (I) Item:** the item is under consideration by the Committee but not proposed for Voting; **(V) Voting Item:** the Committee is making recommendations requiring a vote by the active members of NCWM; **(W) Withdrawn Item:** the item has been removed from consideration by the Committee.

Table B provides a summary of the results of the voting on the Committee’s items and the report in its entirety. Some Voting Items are considered individually, others may be grouped in a consent calendar. Consent calendar items are Voting Items that the Committee has assembled as a single Voting Item during their deliberation after the Open Hearings on the assumption that the items are without opposition and will not require discussion. The Voting Items that have been grouped into consent calendar items will be listed on the addendum sheets. Prior to adoption of the consent calendar, the Committee entertains any requests from the floor to remove specific items from the consent calendar to be discussed and voted upon individually.

Proposed revisions to the handbook(s) are shown as follows: 1) deleted language is indicated with a **bold face font using strikeouts** (e.g., ~~this report~~), and 2) proposed new language is indicated with an **underscored bold faced font** (e.g., new items). When used in this report, the term “weight” means “mass.”

Note: The policy of NIST is to use metric units of measurement in all of its publications; however, recommendations received by NCWM technical committees and regional weights and measures associations have been printed in this publication as submitted. Therefore, the report may contain references to inch-pound units.

Subject Series List

Introduction	200 Series
NIST Handbook 130 – General	210 Series
Uniform Laws.....	220 Series
Uniform Weights and Measures Law.....	221 Series
Uniform Weighmaster Law.....	222 Series
Uniform Engine Fuels and Automotive Lubricants Inspection Law	223 Series
Uniform Regulations	230 Series
Uniform Packaging and Labeling Regulation	231 Series
Uniform Regulation for the Method of Sale of Commodities	232 Series
Uniform Unit Pricing Regulation	233 Series
Uniform Regulation for the Voluntary Registration of Servicepersons and Service Agencies for Commercial Weighing and Measuring Devices.....	234 Series
Uniform Open Dating Regulation	235 Series
Uniform Regulation for National Type Evaluation.....	236 Series
Uniform Engine Fuels and Automotive Lubricants Regulation	237 Series
Examination Procedure for Price Verification.....	240 Series
NCWM Policy, Interpretations, and Guidelines, Section 2	250 Series
NIST Handbook 133.....	260 Series
Other Items – Developing Items.....	270 Series

Table A
Table of Contents

Reference Key	Title of Item	Page L&R
200	INTRODUCTION.....	1
231	NIST HANDBOOK 130 – UNIFORM PACKAGING AND LABELING REGULATION	6
231-1	D Sections 6.4., 6.5., 6.7., 6.8.1., 6.8.2., 6.9., and 10.8. Addition of Tables	6
231-2	V Section 10.3. Aerosols and Self-Pressurized Containers	14
232	NIST HANDBOOK 130 – UNIFORM REGULATION FOR THE METHOD OF SALE	
COMMODITIES		18
232-1	D Section 2.20.3. Street Sign Prices and Advertising.....	18
232-2	W Section 2.27. Retail Sales of Natural Gas Sold as a Vehicle Fuel	19
232-3	V Section 2.27. Retail Sales of Natural Gas Sold as a Vehicle Fuel	22
232-4	V Section 2.33. Oil.....	26
232-5	W Section 2.XX. Printer Ink and Toner Cartridges Labeling.....	30
232-6	V Section 2.30. E85 Fuel Ethanol Flex Fuel Blends	35
232-7	V Section 2.XX. Diesel Exhaust Fluid (DEF).....	38
232-8	V Section 2.20. Gasoline-Oxygenate Blends.....	40
237	NIST HANDBOOK 130 – UNIFORM ENGINE FUELS AND AUTOMOTIVE	
LUBRICANTS REGULATION		42
237-1	W Section 1. Definitions - Diesel Liter Equivalent (DLE) and Diesel Gallon Equivalent (DGE)	42
237-2	V Section 1. Definitions - Diesel Liter Equivalent (DLE) and Diesel Gallon Equivalent (DGE): Compressed Natural Gas, Section 1. Definitions - Diesel Liter Equivalent (DLE) and Diesel Gallon Equivalent (DGE): Liquefied Natural Gas, Section 3.11. Compressed Natural Gas (CNG) and Section 3.12. Liquefied Natural Gas (LNG)	43
237-3	W Section 1. Definitions - Diesel Liter Equivalent (DLE) and Diesel Gallon Equivalent (DGE): Liquefied Natural Gas.....	50
237-4	I Sections 2.1.3. Minimum Antiknock Index (AKI), Section 2.1.4. Minimum Motor Octane Number, and Section 3.2.5. Prohibition of Terms – Table 1.	51
237-5	W Section 3.11. Compressed Natural Gas (CNG) and Section 3.12. Liquefied Natural Gas (LNG)	53
237-6	V Section 3.13. Oil, 3.13.1. Labeling of Vehicle Engine (Motor) Oil Required	56
237-7	V Section 3.2.7. Documentation for Dispenser Labeling Purposes.....	60
237-8	V Section 4.3. Dispenser Filters	61
237-9	V Section 1. Definitions, Section 2. Standard Fuel Specifications, and Section 3. Classification and Method of Sale of Petroleum Items	64
237-10	V Section 3.XX. Diesel Exhaust Fluid (DEF).....	69
237-11	V Section 2.12. Motor Oil	71
260	NIST HANDBOOK 133.....	73
260-1	W Section 3.10. Animal Bedding.....	73
260-2	V Section 3.12. Fresh Oysters Labeled by Volume.....	78
260-3	W Section 4.3. Paper Plates and Sanitary Paper Products.....	82
270	OTHER ITEMS	86
270-1	D Fuels and Lubricants Subcommittee.....	86
270-2	D Packaging and Labeling Subcommittee.....	87
270-3	D Moisture Allowance Task Group (MATG)	88

Appendices

- A. **Items 232-2, 232-3, 237-1, 237-2, 237-3, and 237-5:** Background and Justification for Handbook 130, Definition for “Diesel Gallon Equivalent (DGE)” of Natural Gas as a Vehicular Fuel A1
 - B. **Item 260-2:** Handbook 133, Test Procedures – Packages Labeled by Volume, Section 3.12. Fresh Oysters Labeled by Volume B1
 - C. **Items 232-6 and 237-9:** NIST Handbook 130, Uniform Regulation for the Method of Sale, Section 1. Definitions, Section 2. Standard Fuels Specifications, and Section 3. Classification and Method of Sale for Petroleum Items..... C1
-

Table B
Voting Results

<i>Reference Key Number</i>	<i>House of State Representatives</i>		<i>House of Delegates</i>		<i>Results</i>
	<i>Yeas</i>	<i>Nays</i>	<i>Yeas</i>	<i>Nays</i>	
Consent Calendar					
231-2					Adopted
232-4					Adopted
232-6					Adopted
232-7					Adopted
232-8					Adopted
237-6					Adopted
237-7					Adopted
237-9					Adopted
237-10					Adopted
237-11					Adopted
260-2					Adopted
232-3*	29	9	14	27	Returned to Committee
237-2*	29	9	14	27	Returned to Committee
237-8	14	20	19	11	Returned to Committee

* Items 232-3, 237-2 and 337-2 were voted upon as a block.

Table C
Glossary of Acronyms and Terms

Acronym	Term	Acronym	Term
ACEA	European Automobile Manufacturers Association	HB 44	“Specifications, Tolerances, and Other Technical Requirements for Weighing and Measuring Devices”
AKI	Minimum Antiknock Index	HB 130	“Uniform Laws and Regulations in the Areas of Legal Metrology and Engine Fuel Quality”
AOAC	AOAC International (Association of Analytical Communities)	HB 133	“Checking the Net Contents of Packaged Goods”
AOCA	Automotive Oil Change Association	IEC	International Electrotechnical Association
API	American Petroleum Institute	ISO	International Organization for Standardization
ASTM	ASTM International	L&R	Laws and Regulations
ATC	Automatic Temperature Compensation	LNG	Liquefied Natural Gas
AUS	Aqueous Urea Solutions	MATG	Moisture Allowance Task Group
BOV	Bag on Valve	MAV	Maximum Allowable Variation
BTU	British Thermal Unit	MON	Motor Octane Number
CFR	Code of Federal Regulations	NAA	National Aerosol Association
CNG	Compressed Natural Gas	NADA	National Automobile Dealers Association
CPSC	Consumer Product Safety Committee	NGSC	Natural Gas Steering Committee
CRC	Coordinating Research Council	NCWM	National Conference on Weights and Measures
CWMA	Central Weights and Measures Association	NEWMA	Northeastern Weights and Measures Association
DEF	Diesel Exhaust Fluid	NIST	National Institute of Standards and Technology
DGE	Diesel Gallon Equivalent	OEM	Original Equipment Manufacturer
DLE	Diesel Liter Equivalent	OWM	Office of Weights and Measures
DOE	Department of Energy	PALS	Packaging and Labeling Subcommittee
EPA	Environmental Protection Agency	RON	Research Octane Number
FALS	Fuels and Lubricants Subcommittee	S&T	Specifications and Tolerances
FDA	Food and Drug Administration	SAE	Society of Automotive Engineers
FPI	Foodservice Packaging Industry	SWMA	Southern Weights and Measures
FPLA	Fair Packaging and Labeling Act	TG	Task Group
FTC	Federal Trade Commission	UPLR	Uniform Packaging and Labeling Regulation
GGE	Gasoline Gallon Equivalent	UWML	Uniform Weights and Measures Law
GLE	Gasoline Liter Equivalent	USNWG	U.S. National Work Group
GM	General Motors	WWMA	Western Weights and Measures Assoc.

Details of All Items
(In order by Reference Key)

231 NIST HANDBOOK 130 – UNIFORM PACKAGING AND LABELING REGULATION

231-1 D Sections 6.4., 6.5., 6.7., 6.8.1., 6.8.2., 6.9., and 10.8. Addition of Tables

Source:

NCWM Packaging and Labeling Subcommittee (2014)

Purpose:

Add tables to Handbook 130 to help clarify requirements.

Item Under Consideration:

Amend NIST Handbook 130, Uniform Packaging and Labeling Regulation as follows:

6.4. Terms: Weight, Measure, Volume, or Count. – The declaration of the quantity of a particular commodity shall be expressed in terms of:

- (a) weight if the commodity is solid, semisolid, viscous, or a mixture of solid and liquid;
- (b) volume measure if the commodity is liquid or dry, if the commodity is dry;
- (c) linear measure or area; or
- (d) numerical count.

<u>Table 6.4.</u> <u>Weight, Measure, Volume, or Count</u>	
<u>If the commodity is:</u>	<u>The declaration of quantity shall be expressed in:</u>
<u>(a) solid, semisolid, viscous or a mixture of solid and liquid</u>	<u>weight (mass)</u>
<u>(b) liquid or dry</u>	<u>fluid measure if fluid. dry measures if dry.</u>
<u>(c) linear or area</u>	<u>linear measure or area</u>
<u>(d) individual units</u>	<u>numerical count</u>
<u>Items referenced in the table with a () refers to text in the section indicated with the like identifier.</u>	

However, if there exists a firmly established general consumer usage and trade custom with respect to the terms used in expressing a declaration of quantity of a particular commodity, such a declaration of quantity may be expressed in its traditional terms, provided such traditional declaration gives accurate and adequate information as to the quantity of the commodity. Any net content statement that does not permit price and quantity comparisons is forbidden.

(Amended 1989 **and 20XX**)

6.5. SI Units: Mass, Measure. ^[NOTE 3, page 64] – A declaration of quantity:

- (a) in units of mass shall be the kilogram, gram, or milligram;
- (b) in units of liquid measure shall be the liter or milliliter and shall express the volume at 20 °C, except in the case of petroleum products or distilled spirits, for which the declaration shall express the volume at 15.6 °C, and except also in the case of a commodity that is normally sold and consumed while frozen, for which the declaration shall express the volume at the frozen temperature, and except also in the case of malt beverages or a commodity that must be maintained in the refrigerated state, for which the declaration shall express the volume at 4 °C;
(Amended 1985 and 1990)
- (c) in units of linear measure shall be the meter, centimeter, or millimeter;
- (d) in units of area measure shall be the square meter, square decimeters, square centimeter, or square millimeter;
- (e) in units of volume other than liquid measure shall be the liter and milliliter, except that the units cubic meter and cubic centimeter shall be used only when specifically designated as a method of sale;
- (f) Rule of 1000. – The selected multiple or submultiple prefixes for SI units shall result in numerical values between 1 and 1000. This rule allows centimeters or millimeters to be used where a length declaration is less than 100 centimeters.

Examples:

500 g, not 0.5 kg;
1.96 kg, not 1960 g;
750 mL, not 0.75 L; or
750 mm or 75 cm, not 0.75 m.

(Added 1993)

- (g) SI declarations should be shown in three digits except where the quantity is below 100 grams, milliliters, centimeters, square centimeters, or cubic centimeters, where it may be shown in two digits. In either case, any final zero appearing to the right of the decimal point need not be shown; and
(Added 1993)
- (h) the declaration of net quantity of contents shall not be expressed in mixed units.

Example:

1.5 kg, not 1 kg 500 g.

(Added 1993)

Table 6.5. SI Units: Mass, Measure	
<u>If a declaration of quantity is by:</u>	<u>Then shall be labeled in terms of:</u>
<u>(a) mass</u>	<u>milligram or gram or kilogram</u>
<u>(b) liquid</u>	<u>in units of liquid measure shall be the liter or milliliter and shall express the volume at 20 °C, except in the case of petroleum products or distilled spirits, for which the declaration shall express the volume at 15.6 °C, and except also in the case of a commodity that is normally sold and consumed while frozen, for which the declaration shall express the volume at the frozen temperature, and except also in the case of malt beverages or a commodity that must be maintained in the refrigerated state, for which the declaration shall express the volume at 4 °C</u>
<u>(c) linear measure</u>	<u>Millimeter, centimeter, or meter</u>
<u>(d) area measure</u>	<u>square millimeter, square centimeter, square decimeter, or square meter</u>
<u>(e) dry measure</u>	<u>milliliter or liter except that cubic decimeter or cubic meter may be used if required by a method of sale regulation</u>
<u>(f) Rule of 1000</u>	<u>between 1 and 1000, except that cm or mm may be used below 100 cm (e.g., 500 g not 0.5 kg; 750 mL not 0.75 L)</u>
<u>(g) Digits</u>	<u>should be in 3 digits but if less than 100 g, mL, cm, sq m, cubic cm should be in 2 digits</u>
<u>(h) Mixed Units</u>	<u>1.85 kg not 1 kg 950 g – mixing of units prohibited</u>
<u>Items referenced in the table with a () refers to text in the section indicated with the like identifier.</u>	

6.7. ~~Inch-Pound Units~~ Customary Units: Weight, Measure. – A declaration of quantity:

- (a) in units of weight shall be in terms of the avoirdupois pound or ounce;
- (b) in units of liquid measure shall be in terms of the United States gallon of 231 in³ or liquid quart, liquid pint, or fluid-ounce subdivisions of the gallon and shall express the volume at 68 °F, except in the case of petroleum products and distilled spirits, for which the declaration shall express the volume at 60 °F, and except also in the case of a commodity that is normally sold and consumed while frozen, for which the declaration shall express the volume at the frozen temperature, and except also in the case of a commodity that must be maintained in the refrigerated state, for which the declaration shall express the volume at 40 °F, and except also in the case of malt beverages, for which the declaration shall express the volume at 39.1 °F;
(Amended 1985 and 1990)
- (c) in units of linear measure shall be in terms of the yard, foot, or inch;
- (d) in units of area measure shall be in terms of the square yard, square foot, or square inch;
- (e) in units of volume measure shall be in terms of the cubic yard, cubic foot, or cubic inch; and

- (f) in units of dry measure shall be in terms of the United States bushel of 2150.42 in³, or peck, dry quart, and dry pint subdivisions of the bushel.

<u>Table 6.7.</u> <u>Inch-Pound Customary Units: Weight, Measure</u>	
<u>Declaration of quantity if:</u>	<u>Then it shall be labeled in terms of:</u>
<u>(a) weight</u>	<u>avoirdupois pound or ounce</u>
<u>(b) liquid</u>	<u>fluid ounce, pint, quart, or gallon (231 cubic inches) at 68 °F except for:</u> <u>1. petroleum and distilled spirits at 60 °F</u> <u>2. frozen commodities at frozen temperature</u> <u>3. refrigerated beverages at 40 °F</u> <u>4. malt beverages at 39.1 °F</u>
<u>(c) linear measure</u>	<u>inch, foot, yard</u>
<u>(d) area measure</u>	<u>square inch, square foot, square yard</u>
<u>(e) volume</u>	<u>cubic inch, cubic foot, cubic yard (unless another unit required by method sale regulation such as a "cord" for firewood)</u>
<u>(f) dry measure</u>	<u>dry pint, dry quart, peck, U.S. bushel (2150.42 cubic inches)</u>
<u>All of the quantities shown above may be expressed in common fractions or decimal fractions of the largest unit to no more than three decimal places (e.g., 2.542 lb but not 2.5423 lb).</u>	
<u>Items referenced in the table with a () refers to text in the section indicated with the like identifier.</u>	

6.8. Prescribed Units, ~~Inch-pound~~ Customary Units System.

6.8.1. Less than 1 foot, 1 square foot, 1 pound, or 1 pint. – The declaration of quantity shall be expressed in the following terms:

- (a) in the case of length measure of less than 1 ft, in inches and fractions of inches;
- (b) in the case of area measure of less than 1 ft², in square inches and fractions of square inches;
- (c) in the case of weight of less than 1 lb, in ounces and fractions of ounces; and
- (d) in the case of liquid measure of less than 1 pt, in fluid ounces and fractions of fluid ounces, provided, the quantity declaration appearing on a random package may be expressed in terms of decimal fractions of the largest appropriate unit, the fraction being carried out to not more than three decimal places.

(Amended 1984)

Table 6.8.1. Less than 1 foot, 1 square foot, 1 pound or 1 pint	
<u>If a declaration of quantity LESS than ONE:</u>	<u>It shall be labeled in terms of:</u>
(a) <u>foot</u>	<u>inches or fraction of inches</u>
(b) <u>square foot</u>	<u>square inches or fraction of square inches</u>
(c) <u>pound</u>	<u>ounces or fractions of ounces</u>
(d) <u>pint</u>	<u>fluid ounces and fraction of fluid ounces</u>
<u>All of the quantities shown above may be expressed in common fractions or decimal fractions of the largest unit. Random packages may be labelled to no more than three decimal places.</u>	
<u>Items referenced in the table with a () refers to text in the section indicated with the like identifier.</u>	

6.8.2. One Foot, 1 Square Foot, 1 Pound, 1 Pint, 1 Gallon, or More. – The declaration of quantity shall be expressed in the following terms (see Section 6.2. Largest Whole Unit and Section 6.11. Fractions):

- (a) **Linear Measure.** – If 1 ft or more, expressed in terms of the largest whole unit (a yard or a foot) with any remainder expressed in inches and fractions of the inch or in fractions of the foot or yard, except that it shall be optional to include a statement of length in terms of inches.
- (b) **Area Measure.**
 - (1) If 1 ft² or more, but less than 4 ft², expressed in square feet with any remainder expressed in square inches and fractions of a square inch or in fractions of a square foot; and
 - (2) If 4 ft² or more, expressed in terms of the largest whole unit (e.g., square yards or square feet) with any remainder expressed in square inches and fractions of a square inch or in fractions of the square foot or square yard.
- (c) **Weight.** – If 1 lb or more, expressed in terms of the largest whole unit with any remainder expressed in ounces and fractions of an ounce or in fractions of the pound.
- (d) **Liquid Volume.**
 - (1) If 1 pt or more, but less than 1 gal, expressed in the largest whole unit (quarts, quarts and pints, or pints, as appropriate) with any remainder expressed in fluid ounces or fractions of the pint or quart, except that 2 qt may be declared as ½ gal, and it shall be optional to include an additional expression of net quantity in fluid ounces; or
 - (2) If 1 gal or more, expressed in terms of the largest whole unit (gallons followed by fractions of a gallon or by the next smaller whole unit or units [for example, quarts and pints]) with any remainder expressed in fluid ounces or fractions of the pint or quart, except that it shall be optional to include an additional expression of net quantity in fluid ounces.
- (e) **Dry Measure.** – If 1 dry pt or more, expressed in terms of the largest whole unit with the remainder expressed in fractions of a dry pint, dry quart, peck, or bushel, provided the quantity declaration on a

random package may be expressed in decimal fractions of the largest appropriate unit carried out to not more than three decimal places.

(Amended 1993)

Table 6.8.2. One Foot, 1 Square Foot, 1 Pound, 1 Pint, 1 Gallon, or More	
<u>If a declaration of quantity is:</u>	<u>Then it should be labeled in terms of the largest whole units in:</u>
<u>(a) linear measure:</u> <u>1 foot or more</u>	<u>yards or feet with remainder in inches and fractions of an inch, or in fraction of the foot or yard. Optional declaration of inches is permitted</u>
<u>(b) area measure:</u> <u>(1) 1 square foot or more but less than 4 square feet</u> <u>(2) 4 square feet or more</u>	<u>square feet with remainder in square inches or square feet or in fractions of these units</u> <u>square yards or square feet with remainder in square inches or square feet or in fractions of these units (inches, sq ft, sq yd).</u>
<u>(c) weight:</u> <u>1 pound or more</u>	<u>pounds with remainder in ounces or in fractions of an ounce or pound (e.g., "2 lb 7 ¾ oz" or "1.75 lb")</u>
<u>(d) liquid measure:</u> <u>(1) 1 pint or more but less than 1 gallon</u> <u>(2) 1 gallon or more</u>	<u>quarts, quarts and pints, pints with remainder in fluid ounces or fractions of the pint or quart (2 qt may be ½ gal). Optional declaration of fluid ounces is permitted</u> <u>gallons followed by fractions of a gallon or next smaller whole unit such as quarts or pints. Optional declaration of fluid ounces</u>
<u>(e) dry measure:</u> <u>1 dry pint or more</u>	<u>dry pint, dry quart, peck or bushel with remainder in fractions of those units</u>
<u>Items referenced in the table with a () refers to text in the section indicated with the like identifier.</u>	

6.9. Bi-dimensional Commodities. – For bi-dimensional commodities (including roll-type commodities) the quantity declaration shall be expressed in both SI and ~~inch-pound~~ **customary** units of measurement as follows:

- (a) if the area is less than 929 cm² (1 ft²), in terms of length and width (expressed in the largest whole unit for SI and in linear inches and fractions of linear inches for ~~inch-pound~~ **customary units**);

Example:

20.3 cm × 25.4 cm (8 in × 10 in);

- (b) if the area is at least 929 cm² (1 ft²), but less than 37.1 dm² (4 ft²), in terms of area (expressed in the largest whole unit for SI and in square inches for ~~inch-pound~~ **customary units**), followed by a declaration of the length and width in terms of the largest whole unit:

Example:

31 dm² (49 cm × 64 cm) 3.36 ft² (1.6 ft × 2.1 ft), provided:

- (1) bi-dimensional commodities having a width of 10 cm (4 in) or less, the declaration of net quantity shall be expressed in terms of width and length in linear measure; no declaration of area is required;
- (2) an ~~inch-pound~~ **customary** unit dimension of less than 2 ft may be stated in inches;

- (3) commodities consisting of usable individual units (e.g., paper napkins) require a declaration of unit area but not a declaration of total area of all such units (except roll-type commodities with individual usable units created by perforations, for which see Section 6.10. Count: Ply); and
- (4) ~~inch-pound customary~~ unit declarations may include after the statement of the linear dimensions in the largest whole unit a parenthetical declaration of the same dimensions in inches.

Example:
 25 ft² (12 in×8.33 yd) (12 in × 300 in).

Table 6.9.(a.)(b.) Bi-Dimensional Commodities		
<u>If a declaration of quantity is:</u>	<u>Then it shall be in largest whole units of customary units and SI units of:</u>	<u>Units Expressed In:</u> <u>(See also Sections 6.6. Prescribed Units, SI and 6.8. Prescribed Units, Inch-Pound Customary System Fractions are Permitted.)</u>
<u>(a) area less than 929 cm² (2 ft²)</u>	<u>length and width</u> <u>for example, 20.3 cm × 25.4 cm</u> <u>(8 in x 10 in)</u>	<u>mm, cm, or in</u>
<u>(b) an area of 929 cm² (1 ft²) up to 37.2 dm² (4ft²)</u>	<u>area, length and width</u> <u>for example, 31 dm² (40 × 64 cm)</u> <u>3.36 ft² (1.6 ft × 2.1 ft)</u>	<u>area:</u> <u>sq cm or dm and sq in or ft</u> <u>linear:</u> <u>mm or cm and in or ft</u>
<u>(1) a width of 10 cm (4 in) or less</u>	<u>length and width but NOT area</u>	<u>mm, cm or m and in, ft or yd</u>
<u>(2) for a length or width dimension less than 2 ft</u>	<u>the inch-pound statement may be in inches</u>	<u>mm, cm, in</u>
<u>(3) on packages of individual units (e.g., napkins). See Section 6.10. Count: Ply for perforated roll type products (e.g., paper towels and toilet paper).</u>	<u>unit area but not the total area of all units</u>	<u>area:</u> <u>sq, com, dm, m, and sq in, ft, or yd</u> <u>linear:</u> <u>mm, cm, m or in, ft, or yd</u>
<u>(4) any customary unit declarations</u>	<u>a statement of inches may be provided in addition to largest whole unit e.g. 25 ft² (12 in × 8.33 yd) (12 in × 300 in)</u>	<u>inches</u>
<u>Items referenced in the table with a () refers to text in the section indicated with the like identifier.</u>		

- (c) if the area is 37.1 dm² (4 ft²) or more, in terms of area (expressed in the largest whole unit for SI and in square feet for inch-pound), followed by a declaration of the length and width, in terms of the largest whole unit, provided:
 - (1) no declaration of area is required for a bi-dimensional commodity with a width of 10 cm (4 in) or less;

- (2) bi-dimensional commodities with a width of 10 cm (4 in) or less, the inch-pound statement of width shall be expressed in terms of linear inches and fractions thereof, and length shall be expressed in the largest whole unit (yard or foot) with any remainder in terms of fractions of the yard or foot, except that it shall be optional to express the length in the largest whole unit followed by a statement of length in inches or to express the length in inches followed by a statement of length in the largest whole unit;

Examples:

- 5 cm × 9.14 m (2 in × 10 yd); or
 5 cm × 9.14 m (2 in × 10 yd) (360 in); or
 5 cm × 9.14 m (2 in × 360 in) (10 yd).

- (3) a customary unit dimension of less than 2 ft may be stated in inches; and
- (d) no declaration of area is required for commodities for which the length and width measurements are critical in terms of end use (such as wallpaper border) if such commodities clearly present the length and width measurements on the label.

Table 6.9.(c).(d.) Bi-Dimensional Commodities (including roll type packages)		
<u>If a declaration of quantity is:</u>	<u>Then it shall be in largest whole units with statements in customary units and SI units of:</u>	<u>Units Expressed in: See also Sections 6.6. Prescribed Units, SI and 6.8. Prescribed Units, Customary System (fractions permitted).</u>
<u>(c) for area of 37.1 dm² (4 ft²) or more (see 1, 2, and 3 below)</u>	<u>area, length, and width</u>	<u>area: sq dm or sq cm and sq ft. Linear: mm or cm and in, ft or yd</u>
<u>(1) and (2) for a width of 10 cm (4 in) or less</u>	<u>width and length but NOT area</u> <u>Examples:</u> <u>5 cm x 9.14 m (2 in × 10 yd), or</u> <u>5 cm x 9.14 m (2 in × 10 yd) (360 in), or</u> <u>5 cm x 9.14 m (2 in × 360 in) (10 yd)</u>	<u>linear:</u> <u>mm, cm or m</u> <u>inch-pound: width in inches</u> <u>length:</u> <u>ft or yd and may include inches</u>
<u>(3) For length or width dimensions less than 2 ft</u>	<u>inch-pound customary units statement may be in inches</u>	<u>inches</u>
<u>(d) on packages where length and width are critical for end use (e.g., wallpaper and borders)</u>	<u>width and length but NOT area</u>	<u>mm, cm or m and in, ft or yd</u>
<u>Items referenced in the table with a () refers to text in the section indicated with the like identifier.</u>		

Background/Discussion:

The tables were developed from a PowerPoint presentation provided at a NIST Packaging and Labeling Class for industry and regulators. Attendees found the tables to be an excellent reference material as they were challenged to evaluate various packaged commodities for compliance with the Uniform Packaging and Labeling Regulation.

The addition of tables to NIST Handbook 130 would be useful to industry and regulators in interpreting requirements. No revisions of current requirements would be necessary. Marketing and art departments, amongst others, are challenged with developing the packaging and labeling for products being distributed by their companies

or clients, and individuals in those professions would find it helpful to have the additional examples provided in the tables for reference.

Several other tables are already provided in NIST Handbook 130, and these new tables are viewed as being equally helpful. For example, in NIST Handbook 130 (2014), Table 1. Rounding Rules on page 98 describes rounding rules and Table 2. Examples on page 100 assist with conversions.

2014 NCWM Interim Meeting: It was mentioned that there are numerous technical errors and typographical errors within the submitted charts. The subsections in the tables do not coincide with the language printed within NIST Handbook 130. During Committee worked session, it was mentioned that developing tables for items within the NIST handbooks could set precedence for all items to have a table. NIST commented that they do provide a publication, NIST SP 1020 Series, *Consumer Packaging Labeling Guides*. The NIST SP 1020 Guides are quite popular and extremely user-friendly. The Committee would like to have feedback from the Regions on this item. They also requested the PALS (original submitter) correct the tables to align with the language as it appears with the handbook.

Regional Association Comments:

CWMA's L&R Committee believes the revisions would improve the use of NIST Handbook 130 and provide clearer understanding by users. CWMA forwarded the item to NCWM, recommending it as a Voting item. At the 2014 CWMA Meeting, no comments were heard during the L&R Committee Open Hearings. CWMA believes the item has merit, but agrees that the PALS needs to further develop the item.

WWMA received an explanation from a NIST Technical Advisor that the tables were used to help explain the requirement of the UPLR as a teaching aid in its April 2013 seminar, which was open to industry. Industry saw great value and expressed how these tables were helpful and user friendly, indicating compliance could be increased if tables were added the Handbook. There is no change to existing language in the UPLR, it is only taking existing language and putting it in a more readable table format. The tables are supplemental and not intended to replace what currently exists. The PALS Chairman added that the intent is to be content neutral, noting that putting information in table format is more user-friendly. A regulatory official agreed that tables are helpful and easier to follow. WWMA forwarded this item to NCWM and recommended it as a Voting item.

NEWMA: At the 2014 Interim Meeting, the Committee forwarded this item to NCWM recommending it as a Voting item. During the 2014 NEWMA Annual Meeting, no comments were received, and it was recommended the item continue as a Developing item.

SWMA forwarded the item to NCWM recommending it as a Voting item as it is intended to make the requirements easier to understand with the table format added but will not change any of the requirements.

231-2 V Section 10.3. Aerosols and Self-Pressurized Containers

(This item was Adopted.)

Source:

Commonwealth of Massachusetts Division of Standards (2012)

Purpose:

To allow for a quantity statement in terms of weight for packages utilizing the Bag on Valve (BOV) technology; where the propellant is not expelled when the valve is activated. NIST Handbook 130, Section 10.3. Aerosols and Similar Pressurized Containers require aerosols and similar pressurized containers that expel the propellant along with the product to disclose the net quantity in terms of weight.

Item Under Consideration:

Amend NIST Handbook 130, Uniform Packaging and Labeling Regulation as follows:

10.3. Aerosols and ~~Similar~~ Other Pre-Pressurized Containers Dispensing Product Under Pressure. – The declaration of quantity on an aerosol and on ~~a similar other pre-~~pressurized containers dispensing products

under pressure package shall disclose the net quantity of the commodity (including propellant, **where applicable**), in terms of weight, that will be expelled when the instructions for use as shown on the container are followed.

Note: Enforceable on packages using bag-on-valve (BOV) technology after January 1, 2018. (Amended 2014)

Background/Discussion:

There are a number of products in the marketplace bearing quantity statements in terms of fluid measure that utilize the BOV technology. Packages using BOV technology are non-aerosol by definition because the propellant is not dispensed with the product. Consumers cannot do price and quantity comparison between product packaged using BOV technology and similar product in aerosol packaging because the aerosol packaged product includes the propellant in the net weight and the propellant is dispensed with the product. In the example below, two similar products are pictured, however the one on the left is labeled by net weight, and the one on the right is labeled by liquid measure.



BOV technology is environmentally friendlier because the propellant is not dispensed with the product. Products utilizing the BOV technology only expel the product as the product is contained in a bag which is surrounded by the propellant inside the container. In April 2011, NIST, OWM received a letter supporting labeling of certain products such as the “Pure Citrus” product pictured (left) by liquid measure.

2012 NCWM Interim Meeting: The Committee reviewed several letters from different manufacturers that use BOV technology recommending liquid volume as the appropriate method of sale for products in BOV style packaging. Concern was expressed that consumers would not be able to make value comparisons if similar items had different units of measure.

Mr. Van Slyke (Lock Lord Bissell & Liddell LLP/Blue Magic, Inc.) provided a presentation indicating that they believe BOV does not fall under the aerosol guidelines. The reasoning is that a BOV container does not expel propellant with the product; therefore, it inherently has less net weight. They believe that consumers do not have sufficient information to know differences between aerosols and BOV products. Mr. Van Slyke recommended two solutions amending the UPLR language as follows:

10.3. Aerosols and Similar Pressurized Containers. – The declaration of quantity on an aerosol package and on a similar pressurized package shall disclose the net quantity of the commodity (including propellant), in terms of weight, that will be expelled when the instructions for use as shown on the container are followed, **provided however that containers that separate propellant from the expelled product so that propellant is not expelled (such as containers using bag-on-valve technology) may be labeled either with weight or volume of the quantity of the commodity that will be expelled.**

or

10.3. Aerosols and Similar Pressurized Containers. – The declaration of quantity on an aerosol package and on a similar pressurized package shall disclose the net quantity of the commodity (including propellant), in terms of weight, that will be expelled when the instructions for use as shown on the container are followed.

10.3.1. Containers that separate propellant from the expelled product so that the propellant is not expelled (such as containers using bag-on-valve technology) shall be prominently labeled NON-AEROSOL. The declaration of quantity shall disclose the net quantity of the commodity in terms of fluid measure.

Mr. Douglas Raymond (National Aerosol Association [NAA]) gave a presentation reporting the association's position that a container using BOV technology is an aerosol, and its net quantity needs to be declared in terms of net weight. He remarked that BOV has been around for twenty plus years and is not new to the marketplace. Various products are packaged using the BOV technology (e.g., sunscreen, wound washes, shaving cream, and car products). Different aerosol forms use liquid gas, compressed gases, and in barrier forms using Sepro, bladder, and BOV. Mr. Raymond also stated that BOV and non-BOV products are designed to expel their products equally. He stated that classifying a BOV container as a non-aerosol is misleading and a safety concern since this product is pressurized.

A regulatory official agreed that BOV containers should be labeled and tested by net weight. He remarked that test procedures need to be clarified for BOV containers. For example, should the bag be removed from the canister to recover the product?

Concern was also expressed that consumers would be confused if they encountered similar products with different unit pricing and, if the products contents are labeled differently. The BOV proposal that was represented during the 2012 NCWM Interim Meeting was based upon the views of the room air fresheners industry only.

The Committee would like to have a better understanding of the variety and type of products in the marketplace and what is under current development. Clarification is needed for the term "similar products" for example, what products meet this classification as defined in NIST Handbook 130, UPLR, Section 10.3. Aerosols and Similar Pressurized Containers. The Committee is also requesting from NIST, OWM clarification on the definition of aerosol and a review for any updates to NIST Handbook 130, Interpretations and Guidelines, Section 2.2.7. Aerosol Packaged Products. The 2012 L&R Committee designated this as an Informational Item.

2013 NCWM Interim Meeting: The Committee received and reviewed several letters from BOV manufacturers. The letter from National Aerosol Association (NAA) contained draft language that proposes dual labeling for the method of sale on the product label. The Committee discussed that there is no applicable volumetric test procedure. It was stated that allowing two methods of sales is in opposition of the OIML TC 6 Committee on Prepackaged Products, which resolved that aerosols should be declared by weight. The Committee was in agreement that if industry could develop a test procedure they would readdress the issue. The Committee revised the item under consideration to include terminology to include "bag on valve." The Committee recommends this item be an Informational Item to allow time for manufacturers to provide feedback on the time frame for labeling to change over and to research a volumetric test procedure.

Mr. Hank Pickens (Beaumont) provided a presentation at the 2013 NCWM Annual Meeting describing the procedures and reasoning for BOV to be labeled by volumetric measure. Mr. Pickens opposes NAA's proposal for BOV to have a dual unit label. Douglas Raymond (National Aerosol Association [NAA]) is in support of a weight statement due to the challenge in testing this product. Mr. Raymond remarked that BOV products can be in liquid, paste, and powder forms. A NIST Technical Advisor remarked that a volumetric method of sale would be in conflict with federal law regardless of whether it is an aerosol or not. Mr. Sefcik (NIST, OWM) has agreed to host a meeting at NIST in Gaithersburg, Maryland, and bring interested federal agencies (i.e., FDA, FTC, and EPA) and stakeholders together. The Committee would like to see the outcome from this meeting.

2014 Interim Meeting: A NIST Technical Advisor provided a briefing from the NIST January 2014 meeting and there was unanimous agreement that weight shall be the required method of sale for all pressurized containers regardless of the technology. There was also agreement from all parties that an enforcement exemption be granted for three years to allow manufacturers to turn over their current stock of product. The Committee received several letters from aerosol and BOV manufacturers.

The Committee reviewed the language as it appeared in NCWM Publication 15 (2014) and made modifications as it appears in the item under consideration.

10.3. Aerosols and Similar Pressurized Containers. – The declaration of quantity on an aerosol **package including Bag on Valve (BOV) technology** and **other** similar pressurized packages shall disclose the net quantity of the commodity (including propellant), in terms of weight, that will be expelled when the instructions for use as shown on the container are followed.

Note: Packages that utilize the Bag on Valve (BOV) technology shall be enforceable after month/day/20XX.
(Amended 20XX)

2014 NCWM Annual Meeting: Modified language for the item under consideration was submitted by Mr. K. Floren (Los Angeles County). The Committee agreed to modify the language in its Interim Report to that shown in this Final Report in the item Under Consideration.

Regional Association Comments:

CWMA recommends the item remain informational to allow time to receive information from a meeting that is scheduled to be held at NIST in Gaithersburg, Maryland, after the NCWM Annual Meeting. This meeting will bring together interested federal agencies (i.e., FDA, FTC, and EPA) and stakeholders. Since 2012, CWMA has recommended the item remain Informational. NIST has been working with other agencies and organizations to determine that this regulation will not have conflicts. At the 2014 CWMA Meeting, it was agreed this language helps clarify that all self-pressurized containers are sold by weight and recommends this as a Voting item.

WWMA was informed by a NIST Technical Advisor remarked that a meeting is scheduled for January 9, 2014, at NIST, which will include representation from EPA, FTC, FDA, CPSC, industry regulators, and interested stakeholders. A report will be provided at the 2014 NCWM Interim Meeting. A regulatory official indicated that net weight is preferred as different products have varying volatility, which affects the testing procedure. An industry representative stated this is a competitive business issue and was concerned about the safety aspect of testing this product. The Committee recommended that this be an Informational item.

NEWMA heard a comment in 2011, that testing for content could be problematic and that marking on the package should be net weight of product only, not including propellant, which is not part of product. The Committee believed there is better comparison of net contents of product being sold if words "NON-AEROSOL PRODUCT" are added to product label. NEWMA forwarded the item to NCWM recommending it as a Voting item with the following revision: add to the container language "A NON-AEROSOL PRODUCT." At the 2012 Annual Meeting there was discussion about a conflict between aerosols and bag on valve (BOV) products and their declaration of content in the marketplace. NEWMA recommended that the item remain as an Informational item. The same status was recommended during the 2012 NEWMA Interim and Annual Meetings. At the 2013 Interim Meeting, NEWMA attendees were informed that NIST, OWM will be hosting a meeting in January 2014, which will include federal regulatory agencies, stakeholders, and weights and measures regulators to discuss a method of sale. NEWMA would like to see the outcome of this meeting and recommended the item be an Informational item. During the 2014 NEWMA Annual Meeting, based on the results of the January 2014 meeting at NIST this item is fully developed and is recommending that it be a Voting item.

SWMA heard concern in 2011 by an industry weights and measures consultant over an acceptable test procedure that would be used if volume was permitted. The NIST Technical Advisor noted that no specific language has been proposed and that the UPLR Section 6.4., Terms: Weight, Measures, Volume, or Count declares that "any net content statement that does not permit price and quantity comparison is forbidden". It was further noted that NIST Handbook 130, Section 10.3. Aerosols and Similar Pressurized Containers, applies to aerosols and similar pressurized containers. One manufacturer has provided input to this proposal. The National Aerosol Association (NAA) was contacted for input into this proposal. Preliminary comment by NAA was that BOV technology or versions of it have been around since the 1990s. The NAA Board of Directors member believes BOV technology is considered an aerosol, basing his opinion on a California Air Resources Board Regulation. The SWMA Committee requested that specific language be developed for this item and a complete response from the NAA. They also noted that test procedures will need to be discussed if a volume statement is to be considered. SWMA forwarded the item to NCWM recommending it as a Developing item.

In 2012, SWMA withheld comment until NAA offers proposed language at the 2013 NCWM Interim Meeting. SWMA recommended that the item be an Informational item. In 2013, SWMA recommended this item remain on the NCWM agenda as an Informational item, pending the outcome of a meeting being hosted by NIST in January 2014, on this issue.

Additional letters, presentations, and data may have been part of the Committee's consideration. To review the supporting documentation, please refer to the *Report of the 98th National Conference on Weights and Measures* (SP 1171, 2013).

232 NIST HANDBOOK 130 – UNIFORM REGULATION FOR THE METHOD OF SALE COMMODITIES

232-1 D Section 2.20.3. Street Sign Prices and Advertising

Source:

Retail Motor Fuel Dispenser Price Posting and Computing Capabilities Task Group (2014)

Purpose:

Ensure that consumers are not charged a higher price per gallon for motor fuel than what it advertised on a street sign.

Item under Consideration:

Amend NIST Handbook 130, Uniform Regulation for the Method of Sale of Commodities as follows:

2.20. Gasoline-Oxygenate Blends.

2.20.1. Method of Retail Sale. – Type of Oxygenate must be Disclosed – All automotive gasoline or automotive gasoline-oxygenate blends kept, offered, or exposed for sale, or sold at retail containing at least 1.5 mass percent oxygen shall be identified as “with” or “containing” (or similar wording) the predominant oxygenate in the engine fuel. For example, the label may read “contains ethanol” or “with MTBE.” The oxygenate contributing the largest mass percent oxygen to the blend shall be considered the predominant oxygenate. Where mixtures of only ethers are present, the retailer may post the predominant oxygenate followed by the phrase “or other ethers” or alternatively post the phrase “contains MTBE or other ethers.” In addition, gasoline-methanol blend fuels containing more than 0.15 mass percent oxygen from methanol shall be identified as “with” or “containing” methanol. This information shall be posted on the upper 50 % of the dispenser front panel in a position clear and conspicuous from the driver’s position in a type at least 12.7 mm (½ in) in height, 1.5 mm (1/16 in) stroke (width of type).

(Amended 1996)

2.20.2. Documentation for Dispenser Labeling Purposes. – At the time of delivery of the fuel, the retailer shall be provided, on an invoice, bill of lading, shipping paper, or other documentation a declaration of the predominant oxygenate or combination of oxygenates present in concentrations sufficient to yield an oxygen content of at least 1.5 mass percent in the fuel. Where mixtures of only ethers are present, the fuel supplier may identify either the predominant oxygenate in the fuel (i.e., the oxygenate contributing the largest mass percent oxygen) or, alternatively, use the phrase “contains MTBE or other ethers.” In addition, any gasoline containing more than 0.15 mass percent oxygen from methanol shall be identified as “with” or “containing” methanol. This documentation is only for dispenser labeling purposes; it is the responsibility of any potential blender to determine the total oxygen content of the engine fuel before blending.

(Added 1984) (Amended 1985, 1986, 1991, and 1996)

2.20.3. Street Sign Prices and Advertising

(a) The unit price must be in terms of price per gallon in 1/10 cents.

(b) When the price of fuel increases, the street sign must be changed before or simultaneous when the price at the pump is changed. When the price of fuel decreases, the price at the pump must be changed before or simultaneous when the street sign price is changed.

(Added 20XX)

Background/Discussion:

The consumer should never pay more for fuel than the advertised price. A street sign price posting that is lower than the price at the pump, could unfairly draw business from a competitor.

2014 NCWM Interim Meeting: The Committee heard from Mr. Hornbach (Chevron) who spoke in regards to electronic price signs that have the capability to change pumps and signs simultaneously. He recommends that the word “simultaneous” be added into the proposal. Ms. Elson-Houston (Chair of the Retail Motor Fuel Dispenser Price Posting and Computing Capabilities Task Group) concurs with this change. The Committee does not feel this item is developed enough and request that the Task Group (TG) ensure that all sections of the method of sale are addressed in regards to price posting, multi-tier and dual pricing with fuels. The Committee would like the regions to review and comment on this item. Ms. Elson-Houston informed the Committee that the Price Posting TG will be disbanding in July 2014. At the 2014 NCWM Annual Meeting, the Committee agreed this item had merit and recommended continued development by the submitter.

Regional Associations Comments:

This item was submitted directly to the Standing Committee from the NCWM Price Posting TG after the deadlines for submitting to the regional associations.

2014 NEWMA Annual Meeting: No comments were received and the recommendation was to maintain this item as Developing.

2014 CWMA Annual Meeting: An industry representative expressed concern over language requiring tenth-of-a-percent price posting; industry requests price posting to the whole cent; the same representative expressed concern that signs need to change “simultaneously,” and suggested the word “concurrent” be substituted. A second industry representative stated that just because the technology is available, all retail stations do not necessarily have the newest equipment. A regulator stated the use of price per metric units should be recognized as well (i.e., liters). The Committee agreed that based on the comments provided, the item needs further development.

Additional letters, presentations, and data may have been part of the Committee’s consideration. To review the supporting documentation, please refer to the *Report of the 98th National Conference on Weights and Measures* (SP 1171, 2013).

232-2 W Section 2.27. Retail Sales of Natural Gas Sold as a Vehicle Fuel

(This item was Withdrawn.)

Source:

Clean Vehicle Education Foundation (2013)

Purpose:

Enable consumers to make cost and fuel economy comparisons between diesel fuel and natural gas.

Item Under Consideration:

Amend NIST Handbook 130, Uniform Regulation for the Method of Sale of Commodities as follows:

2.27. Retail Sales of Natural Gas Sold as a Vehicle Fuel.

2.27.1. Definitions.

2.27.1.1. Compressed Natural Gas (CNG). – A gaseous fuel composed primarily of methane that is suitable for compression and dispensing into a fuel storage container(s) for use as an engine fuel.

2.27.1.2. Gasoline Liter Equivalent (GLE). – Gasoline liter equivalent (GLE) means 0.678 kg of **compressed** natural gas.

2.27.1.3. Gasoline Gallon Equivalent (GGE). – Gasoline gallon equivalent (GGE) means 2.567 kg (5.660 lb) of **compressed** natural gas.

2.27.1.4. Diesel Liter Equivalent (DLE). – means **0.756 kg of natural gas.**

2.27.1.5. Diesel Gallon Equivalent (DGE). – means **2.894 kg (6.38 lb) of natural gas.**

2.27.1.6. Liquefied Natural Gas (LNG). - **A gaseous fuel composed primarily of methane that has had carbon dioxide removed and nitrogen reduced to 0.5 % by volume and is suitable for liquefaction at – 162 °C (– 259 °F) and dispensed into an insulated cryogenic fuel storage container(s) for use as an engine fuel.**

2.27.1.7. Diesel Liter Equivalent (DLE). – **Diesel liter equivalent means 0.7263 kg of liquefied natural gas.**

2.27.1.8. Diesel Gallon Equivalent (DGE). – **Diesel gallon equivalent means 2.749 kg (6.06 lb) of liquefied natural gas.**

2.27.2. Method of Retail Sale and Dispenser Labeling.

2.27.2.1. Method of Retail Sale. – All **compressed** natural gas kept, offered, or exposed for sale and sold at retail as a vehicle fuel shall be in terms of ~~the gasoline liter equivalent (GLE) or gasoline gallon equivalent (GGE);~~

(a) the gasoline liter equivalent (GLE) or gasoline gallon equivalent (GGE), or

(b) the diesel liter equivalent (DLE) or diesel gallon equivalent (DGE).

2.27.2.2. Dispenser Labeling. – All retail **compressed** natural gas dispensers shall be labeled with the conversion factor in terms of kilograms or pounds. The label shall be permanently and conspicuously displayed on the face of the dispenser and shall have ~~either the statement “1 Gasoline Liter Equivalent (GLE) is equal to 0.678 kg of Natural Gas” or “1 Gasoline Gallon Equivalent (GGE) is equal to 5.660 lb of Natural Gas” consistent with the method of sale used;~~

(a) either the statement “1 Gasoline Liter Equivalent (GLE) is equal to 0.678 kg of Natural Gas” or “1 Gasoline Gallon Equivalent (GGE) is equal to 5.660 lb of Natural Gas” consistent with the method of sale used.

(b) either the statement “1 Diesel Liter Equivalent (DLE) is equal to 0.756 kg of Natural Gas” or “1 Diesel Gallon Equivalent (DGE) is equal to 6.312 lb of Natural Gas” consistent with the method of sale used.

2.27.2.3. Method of Retail Sale. – **All liquefied natural gas kept, offered, or exposed for sale and sold at retail as a vehicle fuel shall be in terms of diesel liter equivalent (DLE) or diesel gallon equivalent (DGE).**

2.27.2.4. Dispenser Labeling. – **All retail liquefied natural gas dispensers shall be labeled with the conversion factor in terms of kilograms or pounds. The label shall be permanently and conspicuously displayed on the face of the dispenser and shall have the statement “1 Diesel Liter**

Equivalent (DLE) is equal to 0.7263 kg of Natural Gas” or “1 Diesel Gallon Equivalent (DGE) is equal to 6.06 lb of Natural Gas” consistent with the method of sale used.

Background/Discussion:

The gasoline gallon equivalent (GGE) unit was defined by NCWM in 1994 (refer to Appendix A) to allow users of natural gas vehicles to readily compare costs and fuel economy of light-duty natural gas vehicles with equivalent gasoline powered vehicles. For the medium and heavy duty natural gas vehicles in widespread use today, there is a need to officially define a unit (already in widespread use) allowing a comparison of cost and fuel economy with diesel powered vehicles. Natural gas is sold as a vehicle fuel as either compressed natural gas (CNG) or liquefied natural gas (LNG) and each method of sale is measured in mass. Therefore, the generic term natural gas is proposed to be used in NIST Handbooks 44 and 130 without the existing term “compressed.” (The mathematics justifying the specific quantity (mass) of natural gas in a DLE and DGE is included in Appendix A.)

The official definition of a DLE and a DGE will likely provide justification for California, Wisconsin, and other states to permit retail sales of LNG for heavy-duty vehicles in these convenient units.

Additional Contacts: Clean Energy, Seal Beach, California, NGV America, Washington, DC, Clean Vehicle Education Foundation, Acworth, Georgia.

2013 NCWM Interim Meeting: A presentation in support of this item was given by Mr. Doug Horne (Clean Vehicle Education Foundation). Several comments were heard regarding the references and databases used to develop the calculations. Concern was expressed with the conversion factors used. Concern was also expressed that the LNG method of sale should be by weight. A NIST, OWM S&T Technical Advisor recommends that L&R and S&T work in a joint session since there is a companion Item 337-1, NIST Handbook 44, “Specifications, Tolerances and Other Technical Requirements for Weighing and Measuring Devices,” Appendix D – Definitions: Diesel Liter and Diesel Gallon Equivalents (DLE, DGE), on the S&T Agenda. A collaborative effort between the two Committees will ensure that the proposed equivalent unit is dispensed accurately at the dispenser. Several attendees spoke in support of the collaborative effort. The Committee will request that the NCWM Board of Directors create a Steering Committee that consists of experts and stakeholders to review this proposal. L&R will prepare a list of comments that they would like the Steering Committee to review and address. The L&R Committee recommends this as Informational item.

At the 2013 NCWM Annual Meeting, the Committee was informed that the Natural Gas Steering Committee chaired by Mahesh Albuquerque would be reviewing this item.

At the 2014 NCWM Interim Meeting Mr. Albuquerque (Chair, National Gas Steering Committee) notified the Committee this item was being withdrawn in its entirety. The submitter of this proposal sent in a modified proposal (Item 232-3) on this subject matter that will be further developed by the Steering Committee. The Committee did note that the factor in Section 2.27.1.6. Liquefied Natural Gas should not read – 126.1 °C, but rather – 162 °C. This item was withdrawn in its entirety.

Regional Association Comments:

CWMA reported that based on the comments received from a majority of states, the Committee does not recommend the proposal as written. Since 2012, regulators from the central region have expressed concerns that LNG and CNG are being sold and there is no standard established through the NCWM process for sales of these products. Establishment of a standard is urgently needed. During the 2013 CWMA Annual Meeting, an industry representative stated that creating an equivalence factor with gallon equivalents was not a weights and measures issue, and some regulators agreed. A NIST representative stated that using equivalence would not allow traceability back to the International System of Units (SI). CWMA recommended the item be withdrawn at the 2013 Annual Meeting. The CWMA recommends the status of this item be Developing at the September 2013 Interim Meeting.

WWMA recognized that Item 232-2 on their agenda is being proposed by submitter to replace this item. Mr. John Wasberg (BLU) and Mr. Michael Eaves (Clean Energy) provided presentations on LNG. Some regulatory officials supported mass as the appropriate method of sale, noting it is based on a traceable standard and there are two alternative methods of sale (hydrogen and electricity) recently adopted by NCWM without using equivalents. Concern was expressed regarding whether it was weights and measures responsibility to verify the conversion factor

and questioned whether the conversion factor would remain constant over time. Mr. Albuquerque, Chairman of the Natural Gas Steering Committee, stated they will continue to meet and consider all related issues and hope to have the item developed for the 2014 NCWM Interim Meeting. A regulatory official noted tax implications, equipment that converts mass to gallon equivalents, and a possible phase in period. WWMA recommended that this item be a Developing item.

NEWMA reviewed the CWMA comments from 2012. A General Motors representative indicated, at that time, there was discussion on a point of reference. A remark pointed out both methods of labeling may be required on a dispenser. The labeling issue may create confusion for the consumer. NEWMA recommended review by the FALS. NEWMA forwarded the item to NCWM L&R Committee recommending it as an Informational item. In 2013, Graham Barker (Clean Vehicle Education Foundation) presented comments in support for this item due to there being no standards for DGE and LNG, and standards are needed for GGE and DGE. Comments were made that definitions do not need to be in the handbook as consumers and fleet managers can research and make informed decisions. The Committee recommends keeping this as an Informational item, and they would like to see a recommendation from the Natural Gas Steering Committee. The Committee should also look at the original 1994 decision on gas equivalent as part of its focus to determine if it should remain in the handbook. NEWMA recommends that this item be an Informational item.

SWMA received a recommendation at their 2012 Annual Meeting from an industry representative that this be designated as Developing item. A regulatory official questioned why industry is not installing the right equipment rather than putting a label on a nozzle. The Committee recommended that this item be reviewed by FALS, in part to check the accuracy of the diesel conversion. The Committee also suggested that the 1994 standard for the GGE be reviewed. SWMA forwarded the item to NCWM, recommending it as an Informational item. At the 2013 SWMA Annual Meeting the majority of regulators spoke in favor of mass being the method of sale but that some states have already recognized the DGE. The Committee received letters supporting the DGE and DLE as the preferred method of sale. A regulator stated they would not support multiple methods of sale. A member asks that all of the conversions factors be a reviewed for accuracy, so everyone can understand what is being debated. Both the S&T and L&R met in joint session to discuss the comments heard and how the two Committees should proceed forward in tandem with this issue. The Committees received a handout from Mr. Brett Barry (Clean Energy) summarizing Natural Gas Vehicle Fuel DGE proposal.

Additional letters, presentations, and data may have been part of the Committee's consideration. To review the supporting documentation, please refer to the *Report of the 98th National Conference on Weights and Measures* (SP 1171, 2013).

232-3 V Section 2.27. Retail Sales of Natural Gas Sold as a Vehicle Fuel

(This item was returned to Committee.)

Source:

Clean Vehicle Education Foundation (2014)

Purpose:

Since natural gas is sold in the retail market place as compressed natural gas (CNG) to be an alternative fuel to gasoline and diesel fuel and as liquefied natural gas (LNG) to be an alternative fuel to diesel, the proposed additions and edits to NIST Handbook 130 will provide definitions for natural gas equivalents for diesel liters and diesel gallons so that end users can readily compare cost and fuel economy. At present, only CNG equivalents for gasoline are included in the handbooks.

Item under Consideration:

Amend the NIST Handbook 130, Method of Sale Regulation as follows:

2.27. Retail Sales of Natural Gas Sold as a Vehicle Fuel.

2.27.1. Definitions.

2.27.1.1. Compressed Natural Gas (CNG). – A gaseous fuel composed primarily of methane that is suitable for compression and dispensing into a fuel storage container(s) for use as an engine fuel.
2.27.1.2. Gasoline Liter Equivalent (GLE). – Gasoline liter equivalent (GLE) means 0.678 kg (1.495 lb) of compressed natural gas.

2.27.1.3. Gasoline Gallon Equivalent (GGE). – Gasoline gallon equivalent (GGE) means 2.567 kg (5.660 lb) of compressed natural gas.

2.27.1.4. Diesel Liter Equivalent (DLE). – Diesel liter equivalent means 0.765 kg of compressed natural gas or 0.726 kg of liquefied natural gas.

2.27.1.5. Diesel Gallon Equivalent (DGE). – Diesel gallon equivalent means 6.384 lb of compressed natural gas or 6.059 lb of liquefied natural gas.

2.27.1.6. Liquefied Natural Gas (LNG). – Natural gas which is predominantly methane that has been – 162 °C (– 260 °F) at 14.696 PSIA and stored in insulated cryogenic fuel storage tanks for use as an engine fuel.

2.27.2. Method of Retail Sale and Dispenser Labeling.

2.27.2.1. Method of Retail Sale. – All compressed natural gas kept, offered, or exposed for sale and sold at retail as a vehicle fuel shall be measured in terms of mass, and indicated in the gasoline liter equivalent (GLE), ~~or~~ gasoline gallon equivalent (GGE), diesel liter equivalent (DLE), or diesel gallon equivalent (DGE) units.

2.27.2.2. Dispenser Labeling Compressed Natural Gas. – All retail compressed natural gas dispensers shall be labeled with the equivalent conversion factor in terms of kilograms or pounds. The label shall be permanently and conspicuously displayed on the face of the dispenser and shall have either the statement “1 Gasoline Liter Equivalent (GLE) is Approximately equal to 0.678 kg of Natural Gas” and “1 Diesel Liter Equivalent (DLE) is Approximately equal to 0.765 kg of Compressed Natural Gas” or the statements “1 Gasoline Gallon Equivalent (GGE) is Approximately equal to 5.660 lb of Compressed Natural Gas” and “1 Diesel Gallon Equivalent (DGE) is Approximately Equal to 6.384 lb of Compressed Natural Gas” consistent with the method of sale used.

2.27.2.3. Method of Retail Sale. – All liquefied natural gas kept, offered, or exposed for sale and sold at retail as a vehicle fuel shall be measured in mass, and indicated in diesel liter equivalent (DLE) or diesel gallon equivalent (DGE) units.

2.27.2.4. Dispenser Labeling of Retail Liquefied Natural Gas. – All retail liquefied natural gas dispensers shall be labeled with the equivalent conversion factor in terms of kilograms or pounds. The label shall be permanently and conspicuously displayed on the face of the dispenser and shall have either the statement “1 Diesel Liter Equivalent (DLE) is Approximately equal to 0.726 kg of Liquefied Natural Gas” or “1 Diesel Gallon Equivalent (DGE) is Approximately equal to 6.059 lb of Liquefied Natural Gas” consistent with the method of sale used.

Background/Discussion:

The gasoline gallon equivalent (GGE) unit was defined by NCWM in 1994 (refer to Appendix A) to allow users of compressed natural gas (CNG) vehicles to readily compare costs and fuel economy of light-duty natural gas vehicles with equivalent gasoline powered vehicles. For the medium and heavy duty natural gas vehicles in widespread use today, there is a need to officially define a unit for both CNG and LNG (already in widespread use) allowing a comparison of cost and fuel economy with diesel powered vehicles. Natural gas is sold as a vehicle fuel as either (CNG or LNG) and each method of sale is measured in mass. The submitter stated that the official definition of a DLE and a DGE will likely provide justification for California, Wisconsin and many other states to permit retail

sales of LNG for heavy-duty vehicles in these convenient units. (The mathematics justifying the specific quantity (mass) of natural gas in a DLE and DGE is included in Appendix A.)

2014 NCWM Interim Meeting: Mr. Albuquerque (Chair, National Gas Steering Committee [NGSC]) notified the Committee that this item is being developed by the NGSC. The Committee noted that the factor in Section 2.27.1.6. Liquefied Natural Gas should not read – 126.1 °C but rather – 162 °C.

The L&R Committee responded to the NGSC's June 10, 2014, request to change the NGSC's March 2014 recommendation for DGE units. The Committee agreed that the CNG and LNG conversion factors proposed for use in converting these gases to DGE units should be revised in the 2014 Interim Report so that their numerical values are expressed to three decimal places rather than two decimal places. These changes are reflected in the following proposed modifications within Section 2.27. Retail Sales of Natural Gas Sold as Vehicle Fuel to read: 1 Diesel Gallon Equivalent (DGE) is ~~6.380~~ 6.384 pounds of Compressed Natural Gas and 1 Diesel Gallon Equivalent of Liquefied Natural Gas is ~~6.060~~ 6.059 pounds.

2014 NCWM Annual Meeting: A joint session was held with L&R and S&T to hear this item. It was noted that if the L&R did not move forward Item 232-3, there would be no reason to proceed with Item 237-2 and S&T Item 337-2. There was discussion regarding the term "approximately equal" found in Sections 2.27.2.2. and 2.27.2.4. It was noted this term was not a measurement equivalency but refers to energy to in energy content. It was recommended that the Committee give consideration to amend the definition and clarify the meaning. Some spoke in opposition that this item would cause consumer confusion in the marketplace, if adopted. Several members questioned where the IRS obtained the numbers that are used in the IRS tax form. NIST provided an alternative proposal to this item and several members believed this proposal should be taken into consideration. Since the proposal from the NGSC was not released until June 10, 2014, members felt they did not have enough time to vet the modification or the NIST proposal. The Committee reviewed numerous letters in support of all the items related to the sale of natural gas as vehicle fuel.

Regional Association Comments:

2014 CWMA Interim Meeting: Comments were made that this item is a duplicate of Item 232-2 with the exception of the conversion factors, which need to be updated in Item 232-1. Based on this, the Committee recommends Withdrawal of this item. CWMA did not forward this item to NCWM.

2014 CWMA Annual Meeting: The Committee heard comments on this item in conjunction with Item 237-2 and S&T Item 337-2. Main points included in the testimony were: An industry representative stated that gaining consensus on these proposals provides the best chance to develop a uniform national standard. Currently, there are legislative bills in six states supporting DGEs and similar activity in many other states including a letter of support with 54 signatures from Congress. An industry representative commented his membership supports the concept, but expressed concern over a discrepancy with equivalencies between the Internal Revenue Service (IRS) definition (126.67 cubic feet per gal) and the steering group's proposal (123 cu ft per gal). He expressed concern that the industry feels these differences must be reconciled, or they will be faced with confusion between the two standards. A second industry representative agreed. A regulator, who served on the steering group, commented that the some members of the steering group attempted to allow for dual declarations on dispensers, using the mass standard as the primary value. He fears adding multiple new standards will add to the confusion. He further stated that he has no objection to supplemental language, but traditional mass unit should be the primary unit.

A NIST Technical Advisor commented there are currently seven different types of fuels, and asked if they should all have gasoline gallon equivalents. A parallel example was provided of selling paint on a square foot wall coverage equivalent. Would weights and measures consider this a viable method of sale?

An industry representative commented that multiple unit pricings could cause confusion, and there were concerns about retrofitting old equipment to allow for multiple unit pricings. He further stated labels are the mechanism by which we convey mass measurement. The same representative commented that some say GGE should have never

been adopted. Another regulator stated natural gas engines are not diesel engines. When posting price equivalence, consumers could be misled or confused as to the energy comparison versus the price comparison.

A NIST Technical Advisor stated a consumer should be aware of what is being measured and that measurement should be accurate. A regulator asked the Conference to recall consideration of equity and uniformity statements in the past. He gave examples of previous items that were artificial declarations and were rejected by the Conference; examples included “lasts the same as,” “burns longer than,” “equivalent to” . . . etc. The regulator stated that in most cases, natural gas has been sold in fleets, so the cost per mile factor has been calculated internally. Sales are now increasing at public fueling locations, so when selling fuel with equivalencies, we are getting into marketing rather than weights and measures functions.

CWMA L&R and S&T Committees met jointly in a working session and concur the items have merit, but questions and concerns over accuracy of this final proposal still remain. Both Committees agreed to move the item forward as an Information item. During the L&R Committee’s work session, discussion took place regarding the inconsistency in language in the method of sale in Item 232-3, Section 2.27.2.; and Item 237-2 Section 3.11.2.1. Additionally, the Committee discussed the importance of including the same number of significant digits in the conversions specified in the DGE and DLE values. The Chairman of the CWMA L&R Committee will communicate these two concerns to the Chairman of the NCWM NGSC.

WWMA did not forward this item to NCWM. See comments in Item 232-2 of this report.

NEWMA: At the 2013 Interim Meeting this item was forwarded to NCWM and was recommended as an Informational item.

At the 2014 NEWMA Annual Meeting, the Committee heard comments on this item in conjunction with S&T Item 337-2. There was a discussion on the item with numerous comments from both industry and regulatory officials. A summary of the comments are as follows:

- GGE and GLE are already established measurements in the marketplace for CNG.
- If the product is measured in mass, it should be sold in mass.
- Equivalent units are not an exact number.
- Consumers have done homework before they buy.
- There is wide support from industry to expand GGE to other fuels.
- CNG is taxed at the federal level based on gallon equivalent. It would be easier to tax by GGE.
- All the reasons heard in support of selling by equivalent units sound like marketing tools.
- NIST Handbook 130 is not a promotional tool! It is about the best way to measure.
- Some states have already adopted GGE or DGE as a method of sale for these alternative fuels.
- Clarify L&R Item 232-3, Section 2.27.2.1. to be consistent with agenda Item 237-2; measured in mass and sold by volume.

Additional comments were heard during the S&T Committee open hearings suggesting the need to include the same number of significant digits in the conversions specified in the proposal for DGE and DLE values. For example, 6.380 and 6.060 contain four significant digits, whereas, 0.765 and 0.726 contain only three significant digits. A recommendation was made to the Committee for it to determine whether or not the values specified are appropriate.

Due to the concerns expressed during the Open Hearings for both Committees, NEWMA voted to recommend to the National L&R and S&T Committees that the status be changed to Informational. This would allow both Committees to revise the agenda items addressing the concerns raised during Open Hearings as well and any concerns involving the IRS method of taxing these products. There are additional related comments located in L&R agenda Item 232-3.

SWMA 2014 Annual Meeting: It was discussed that the submitter wished to modify the original proposal; however, the conversion factors are correct in this item. The S&T and L&R Committees met in a joint session to deliberate on the comments, and during discussion, it was decided the two items should be harmonized and move in tandem. During the joint session, discussion took place on how to move forward on the natural gas items. The Committees received a handout from Mr. Brett Barry (Clean Energy) summarizing the Natural Gas Vehicle Fuel DGE proposal.

The SWMA recommends Withdrawing this item to consolidate all of the information under Item 232-2. SWMA did not forward this item to NCWM.

Additional letters, presentations, and data may have been part of the Committee's consideration. To review the supporting documentation, please refer to the *Report of the 98th National Conference on Weights and Measures* (SP 1171, 2013).

232-4 V Section 2.33. Oil.

(This item was Adopted.)

Source:

Automotive Oil Change Association (AOCA) (2013)

Purpose:

Prevent consumer confusion and government-sponsored product bias regarding legitimate, manufacturer-recommended products, and to prevent installers and retailers from being held responsible for labeling requirements with respect to packaged goods.

Item Under Consideration:

Amend NIST Handbook 130, Uniform Regulation for the Method of Sale of Commodities as follows:

2.33. Oil.

2.33.1. Labeling of Vehicle Engine (Motor) Oil. – Vehicle engine (motor) oil shall be labeled.

2.33.1.1. Viscosity. – The label on any vehicle engine (motor) oil container, receptacle, dispenser, or storage tank, and any invoice or receipt from service on an engine that includes the installation of **bulk** vehicle engine (motor) oil dispensed from a receptacle, dispenser, or storage tank, shall contain the viscosity grade classification preceded by the letters “SAE” in accordance with SAE International’s latest version of SAE J300, “Engine Oil Viscosity Classification.”

Note: If an invoice or receipt from service on an engine has limited room for identifying the viscosity, brand, and service category, then abbreviated versions of each may be used on the invoice or receipt and the letters “SAE” may be omitted from the viscosity classification.

(Note Added 2014)

(Amended 2014)

~~**2.33.1.2. Intended Use.** – The label on any vehicle engine (motor) oil container shall contain a statement of its intended use in accordance with the latest version of SAE J183, “Engine Oil Performance and Engine Service Classification (Other than “Energy Conserving”).”~~

2.33.1.3.2. Brand. – The label on any vehicle engine (motor) oil container and the invoice or receipt from service on an engine that includes the installation of **bulk** vehicle engine (motor) oil dispensed from a receptacle, dispenser, or storage tank shall contain the name, brand, trademark, or trade name of the vehicle engine (motor) oil.

(Amended 2014)

2.33.1.4.3. Engine Service Category. – The label on any vehicle engine (motor) oil container, receptacle, dispenser, or storage tank and the invoice or receipt from service on an engine that includes the installation of **bulk** vehicle engine (motor) oil dispensed from a receptacle, dispenser, or storage tank shall contain the engine service category, or categories, displayed in letters not less than 3.18 mm (1/8 in) in height, as defined by the latest version of SAE J183, “Engine Oil Performance and Engine Service Classification (Other than “Energy Conserving”),” ~~or~~ API Publication 1509, “Engine Oil

Licensing and Certification System,” European Automobile Manufacturers Association (ACEA), “European Oil Sequences,” or other Vehicle or Engine Manufacturer Standards as provided in Section 2.33.1.3.1.

(Amended 2014)

2.33.1.4.3.1. Vehicle or Engine Manufacturer Standard. – **The label on any vehicle engine (motor) oil container, receptacle, dispenser, or storage tank and the invoice or receipt from service on an engine that includes the installation of vehicle engine (motor) oil dispensed from a receptacle, dispenser, or storage tank shall identify the specific vehicle or engine manufacturer standard, or standards, met in letters not less than 3.18 mm (1/8 in) in height. If the vehicle (motor) oil only meets a vehicle or engine manufacturer standard, the label must clearly identify that the oil is only intended for use where specifically recommended by the vehicle or engine manufacturer.**

(Added 2014)

2.33.1.4.1.3.2. Inactive or Obsolete Service Categories. – The label on any vehicle engine (motor) oil container, receptacle, dispenser, or storage tank and the invoice or receipt from service on an engine that includes the installation of **bulk** vehicle engine (motor) oil dispensed from a receptacle, dispenser, or storage tank shall bear a plainly visible cautionary statement in compliance with the latest version of SAE J183, Appendix A, whenever the vehicle engine (motor) oil in the container or in bulk does not meet an active API service category as defined by the latest version of SAE J183, “Engine Oil Performance and Engine Service Classification (Other than “Energy Conserving”).” **If a vehicle engine (motor) oil is identified as only meeting a vehicle or engine manufacturer standard, the labeling requirements in Section 2.33.1.3.1. Vehicle or Engine Manufacturer Standard apply.**

(Amended 2014)

2.33.1.4.5. Tank Trucks or Rail Cars. – Tank trucks, rail cars, and other types of delivery trucks that are used to deliver **bulk** vehicle engine (motor) oil are not required to display the SAE viscosity grade and service category or categories as long as the bill of lading or other documentation provides that information.

(Amended 2013 and 2014)

2.33.1.5.6. Documentation. – When the engine (motor) oil is sold in bulk, an invoice, bill of lading, shipping paper, or other documentation must accompany each delivery. This document must identify the quantity of **bulk** engine (motor) oil delivered as defined in Sections 2.33.1.1. Viscosity; ~~2.33.1.2. Intended Use;~~ 2.33.1.3.2. Brand; 2.33.1.4.3. Engine Service Category; the name and address of the seller and buyer; and the date and time of the sale. For inactive or obsolete service categories, the documentation shall also bear a plainly visible cautionary statement as required in Section 2.33.1.4.1.3.2 Inactive or Obsolete Service Categories. **D**ocumentation must be retained at the retail establishment for a period of not less than one year.

(Added 2013) (Amended 2014)

(Added 2012) (Amended 2014)

Background/Discussion: The vast majority of engine oil used at professional fast lube facilities is the most current category of API (American Petroleum Institute) licensed oil. However, older, specialty, and some non-American vehicles take engine oil not listed as active under API’s private regulatory scheme; some are former API licensed oils now considered “obsolete” or “inactive” and some are simply licensed by another organization like the European Automobile Manufacturers Association (ACEA). However, if original equipment manufacturers (OEM) recommend those engine oils for their vehicles, consumers have a right to use them regardless of API’s blessing, and installers and retailers should be able to sell them without obstruction.

Automotive Oil Change Association (AOCA) amendment is necessary because a cautionary statement appearing on service receipts without explanation will inappropriately mislead consumers with older and uncommon model

vehicles into believing they should not use OEM-recommended engine oil. The average fast lube customer does not recognize API or SAE (Society of Automotive Engineers) to mean anything in particular but “CAUTION” and “OBSOLETE” in big capital letters could only be understood as negative. Scaring consumers in this way will not only push them to buy more expensive engine oil they do not need but also engender distrust in their installer service providers for recommending and/or using OEM-recommended engine oil.

The average age of cars in the current fleet is nearly 11-years old, and it is not unusual for fast lubes to have customers with vehicles twice that age; for example, there are millions of opportunities for consumers to be misled into rejecting proper engine oil. The fact is American consumers are hanging onto their vehicles longer than API is hanging onto its service categories. When API designates a motor oil category as inactive, this does not mean consumers with vehicles designed to use that category turn in their cars or otherwise want to buy a more expensive grade of motor oil going forward. Therefore, a category of motor oil designed to work for particular makes and models of vehicles should not be burdened with the chilling effect of a cautionary statement absent a specific clarification acknowledging the preeminence of the OEM’s recommendations.

The new standard phase-in factor must be considered as well. When API publishes a new edition of 1509, *Engine Oil Licensing and Certification Systems*, and/or creates a new service category, a reasonable phase-in period for bulk oil stock is necessary to accommodate older vehicle owners’ needs; for example, it may be in those customers’ best interests, both functionally and economically, to use motor oil developed in accordance with an earlier edition or service category so long as the automobile manufacturer originally recommended it and its continued use has no impact on any remaining warranty coverage. Although it is common for API to retain a couple of the most recent service categories as “active,” API could choose to make all but the most recent service category “obsolete.” For fast lube operators to automatically upgrade bulk oil stock at API determined intervals would be tantamount to giving API control over the price of oil change services regardless of what the market can bear.

And what about packaged engine oil products already on the shelf or in the distribution chain when API makes a unilateral decision to deactivate an engine oil category? As a practical matter, tens of thousands of retailers and installers cannot re-mark millions of packages to coincide with API’s timing or take the financial hit for sending it all back in violation of purchase agreements. Attempting to enforce the labeling requirement at this level would be a nightmare for everyone involved. The way to avoid this problem is to adopt AOCA’s amendment so that the requirement for proper labeling of packaged containers of engine oil rest with the party in control of the packaging—the manufacturers.

Without the amendment, the labeling requirement will be very difficult to enforce given the inventory of packaged goods remaining after an active engine oil category has been declared inactive or obsolete.

Fast lubes would experience catastrophic business loss if customers with older and uncommon model vehicles were alienated. Maintenance costs for consumers with older model cars could easily double if they are confused into believing they need the latest category of engine oil.

AOCA contends that the proposed amendment will accomplish three important goals: 1) prevent unintended consumer confusion and product stigma from using a cautionary statement by reestablishing the connection to OEM recommendations; 2) provide the necessary exemption to protect retailers and installers for selling lawful packaged inventory; and 3) which leads to an increase in practical enforcement prospects.

The most analogous regulatory situation to the one at issue in AOCA’s proposed amendment is found in the Federal Trade Commissions (FTC) Test Procedures and Labeling Standards for Recycled Oil (16 CFR 311). In that rulemaking process, FTC specifically rejected requiring recycled engine oil to be labeled “recycled” because of the stigma associated with the term at that time (see 72 FR 14410 – 14413 & FN11 [1 H.R. Rep. No. 96–1415, 96th Cong. 2d Sess. 6 (1980), reproduced at 1980 U.S. Code Cong. & Ad. News 4354, 4356. “Oil should be labeled on the basis of performance characteristics and fitness for its intended use, and not on the basis of the origin of the oil.”]). The National Automobile Dealers Association (NADA) also commented in favor of this approach: “NADA further stated that by not requiring that “substantially equivalent” recycled oils be labeled “recycled” or “re-refined,” used oil processors are able to market their products effectively.” (72 FR at 14411) No “recycled” or other potentially derogatory designation is required so long as the finished product meets the appropriate API standard.

2013 NCWM Interim Meeting: A state opposed this item and would like to see it Withdrawn. The FALS Chairman remarked that there are several engine oils designed for specific model vehicles and the FALS is trying to resolve this issue. A Committee member remarked that a statement of accountability should be within the language. The Committee would like to see additional language developed by FALS and made this an Informational item.

2013 NCWM Annual Meeting: The FALS submitted modified language for Sections 2.33.1.4. Engine Service Category, 2.33.1.4.1. Vehicle or Engine Manufacturer Standard and 2.33.1.4.4. Inactive or Obsolete Service Categories. The Committee would like to have regional input on this modified language to review at the 2014 NCWM Interim Meeting.

2014 NCWM Interim Meeting: The FALS and API provided the Committee with modified language. This modified language removes Section 2.33.1.2. Intended Use. For clarification the term “bulk” was added. In Section 2.33.1.1. Viscosity, a note was added to allow for abbreviations on tickets and the term “SAE” may be omitted. One member questioned the labeling for underground storage containers and their legibility. The Committee moved the modified language forward as a Voting item.

2014 NCWM Annual Meeting: The Committee agreed to minor editorial corrections to the language in its Interim Report to that shown in this Final Report in the Item Under Consideration.

Regional Association Comments:

CWMA reported that this item is still under consideration from engine manufacturers and FALS. During previous CWMA meetings (since 2012), various industry representatives have provided comments to the region. AOCA stated that the oil change industry consists of small businesses without legal staff so they need clear guidance that is easily understood. These businesses follow OEM recommendations, which recommend oils that do not follow API or SAE standards. The language should acknowledge that some manufacturers approve and recommend their own oil. AOCA thought that the current language required all OEM oils that did not meet a specific API performance standard to be labeled as obsolete. A GM representative confirmed GM produces its own oils, which does not have an API certification. A FALS member shared the API motor oil guide, which labels specific categories of oil as obsolete (refer to Appendix C in the *Report of the National Conference on Weights and Measures* (SP 1171, 2013). If a manufacturer does not label the oil with an API obsolete category, the product is not considered to be obsolete. OEM manufacturers that were named do not label their oil with an obsolete category, and so oil changers do not need to worry about the obsolete label being used on OEM motor oils. State regulators clarified that nothing is written in the regulation, and that grace periods would be determined on a state-by-state basis. AOCA reiterated that the language should clearly state that OEM oils that do not have API certification are not obsolete. AOCA asked that the Committee recommend this clarifying language. AOCA also stated installers should not be responsible for labeling on packaged products received. A regulatory official stated retailers in other industries are responsible for labeling on packages received, and it would be an unfair market advantage to allow some retailers to use products that were illegally labeled. Since the current language is not clear about exactly what oils are obsolete, the Committee recommended that FALS continue to develop this issue. At the 2013 CWMA Annual Meeting, Mr. Ferrick (API) opposed the language for this item, stating if a product meets an obsolete standard the customer deserves to know this. CWMA would like to see additional information from FALS. An industry representative opposed the proposed language for this item stating if a product meets an obsolete standard the customer deserves to know this. CWMA recommended that the item remain Informational at the May Annual Meeting in 2013.

2014 CWMA Annual Meeting: It was noted that this item has companion Items 237-6 and 237-11. An industry representative commented he supported all items with an additional change to Item 237-11 (see Item 237-11). The Committee believes the item has been fully developed and is recommending it as a Voting item.

WWMA heard comment from Mr. Ferrick (API) who supported the proposed changes to NIST Handbook 130 which are necessary and provided the following reasons: 1) adding the reference to ACEA will expand the current regulation to cover engine oil performance specifications recommended by many European vehicle and engine manufacturers; and, 2) allowing engine oil labels, invoices and receipts to list a performance specification set by a particular vehicle or engine manufacturer will address unique situations where an oil cannot claim any performance level maintained by API or ACEA. The FALS Chair reported it is currently considering these changes, but has not reached consensus, seeking resolution by 2014 NCWM Interim Meeting. WWMA recommended that this be an Informational item.

NEWMA received comment in 2012 from API stating it opposes the item and that specifics have been submitted in writing. API suggested this proposal and Item 237-4 be Withdrawn. General Motors indicated the proposal appears to allow older formulations of engine oil, but newer formulations give better performance, even in older vehicles. GM prefers current formulation of engine oil. NEWMA did not forward the item to NCWM. At the 2013 NEWMA Annual Meeting, testimony was heard that API indicated they submitted comments to their opposition of this item and requested this item be Withdrawn. NEWMA would like to see additional information from FALS. In 2013, the API representative commented to NEWMA that final language review should be made through FALS. No other comments were heard, and NEWMA recommended that this be an Information item. The 2014 NEWMA Annual Meeting recommended that the new clarified language be a Voting item.

SWMA received comment at their 2012 Annual Meeting from an API representative who voiced their opposition to the item and provided written testimony in dispute of the comments and claims made by the submitter. At the 2013 SWMA Annual Meeting, SWMA recommended the item be moved forward as two separate Developing items as FALS had indicated, in order to move the ACEA reference forward.

Additional letters, presentations, and data may have been part of the Committee's consideration. To review the supporting documentation, please refer to the *Report of the 98th National Conference on Weights and Measures* (SP 1171, 2013).

232-5 W Section 2.XX. Printer Ink and Toner Cartridges Labeling

(This item was Withdrawn.)

Source:

Southern Weights and Measures Association (2010)

Purpose:

Clarify the labeling requirements for industry, consumers, and weights and measures officials.

Item Under Consideration:

Amend NIST Handbook 130, Method of Sale Regulation as follows:

2.XX. Printer Ink and Toner Cartridges Labeling.

2.XX.1. Definitions.

2.XX.1.1. Printer Ink Cartridges. – Any cartridge or module that contains ink or a similar substance in liquid form employed in the printing and/or copying of documents, papers, pictures, etc., that is used in a printing device and designed to be replaced when no longer able to supply its contents in printing and/or copying.

2.XX.1.2. Toner Cartridges. – Any cartridge or module that contains toner, powder, or similar non-liquid substance employed in the copying or printing of documents, papers, pictures, etc. that is used in a printing and/or copying device and designed to be replaced when no longer able to supply its contents in printing and/or copying.

2.XX.2. Method of Sale and Labeling.

2.XX.2.1. Method of sale, printer ink cartridges. – All printer ink cartridges kept, offered, or exposed for sale or sold shall be sold in terms of the count.

2.XX.2.2. Method of Sale, toner cartridges. – All toner cartridges kept, offered, or exposed for sale or sold shall be sold in terms of the count.

2.XX.3. Yield Disclosure. – If the seller discloses the yield of printer ink or toner cartridges on the package, then it shall be measured using the latest version of ISO/IEC printer yield standard on the package offered for prepackaged sale. This information shall be considered a supplemental statement.

Note: Labeling shall be enforceable after month/day/20XX.

(Added 20XX)

Background/Discussion:

Over the past several years, there has been a change in the marketplace on inkjet and toner cartridges net content statements. There is little uniformity, and the Committee has seen some labels with a net content or with only a page yield count (e.g., prints 1000 pages). The NIST, OWM pointed out that, according to guidelines printed in NIST Handbook 130, Weights and Measures Law, Section 19. Information Required on Packages, these products are required to have the net contents of the ink (and toner) labeled, but manufacturers have resisted, claiming an exemption under the FPLA. The purpose of this proposal is to specifically clarify the requirements for industry, consumers, and weights and measures officials.

NCWM 2010 Interim Meeting: Mr. Matthew Barkley (Hewlett Packard Co.) commented that the FPLA creates an exemption for ink which extends to toner and ink cartridges. A declaration of weight and volume are not the best way for consumers to make value comparisons. Customers benefit from page count/yield. Mr. Barkley urged that this issue be Withdrawn. If this issue is to proceed, it should be Informational to allow for a review of the FPLA exemption. He suggested that page yield is widely accepted and has repeatability measures.

Mr. Jeran (Hewlett Packard Co.) submitted a white paper from the Information Technology Industry Council (refer to Appendix C in the *Report of the 96th National Conference on Weights and Measures* [SP 1125, 2011]). This white paper included manufacturers from Epson, Hewlett Packard, Kodak, and Lexmark. Mr. Jeran explained that his background is with ink and toner measurement. For the same volume of ink, two different systems of the same model cartridge from two different vendors can print a different number of pages. In order to determine the page yield, they are using the ISO/IEC methodology. ISO is working on a photo yield standard.

An official expressed concerns with page yield being the standard page print for quantity. Variation exists based on the type of cartridge, printer, and font and if graphics/photos are being printed. There is also a concern with what ink cartridge refillers are doing. The Florida official reviewed the current practice of refillers, and said they are stating the amount of ink on labels. There are many manufactured packages in the marketplace, so value comparison to the Original Equipment Manufacturer (OEM) is critical. This is an expensive commodity and clarifications of the requirements are needed. An official recommended that this item not be Withdrawn, but made Informational to allow time for research. Regulatory officials firmly believe that there needs to be a consistency with the declaration statement on these types of items. A consumer stated that the net content needs to be stated with voluntary supplemental information for page yield. Some voiced their opinion that consumers need to know page yield in order to make a value comparison. The NIST Technical Advisor stated that under the FTC regulations ink and toner cartridges were not part of the CFR. NIST, OWM met with the FTC on February 26, 2010, to request clarification of the exemption. According to the Committee, there needs to be a test procedure for verification of net content developed for ink and toner cartridges. The 2010 L&R Committee designated this item as an Informational item until they receive clarification from FTC, review ISO standards, and determine what refillers' current practices are.

NCWM 2010 Annual Meeting: Mr. Pociask (American Consumer Institute) presented a 2007 study done by his organization with funding by a telemarketing research company. An official expressed his concern that the presentation was not clear and asked if page count is based on certain fill levels or declaring the weight on the cartridge itself? Mr. Pociask responded that Quality Logic uses the ISO standards. He concluded that net weight is easy to enforce. Mr. Pociask stressed that his focus is to provide information that gives consumers useful information in purchasing printers and the life cost of the printer, including printer ink cost.

Another official stated that the study was interesting, but would like to hear from manufacturers. There are several issues; cartridges are only for specific printers, when comparing price per page you suggest that price is static, and printer ink cartridge refillers need to be addressed.

Mr. Rosenberg (Information Consumer Industry Council) agreed that providing consumers with information is meaningful; however, relevant to the consumer is the number of pages that can print. The ISO standards are a good tool, but will lead to customer confusion. Mr. Rosenberg said that much more discussion is necessary on this issue (refer to the *Report of the 96th National Conference on Weights and Measures* [SP1125, 2011], Appendix C).

NCWM 2010 Annual Meeting: The Board of Directors established a Printer Ink and Toner Cartridge Task Group (TG) to review and obtain additional information from all stakeholders. Ms. Dempsey (Montgomery County Weights and Measures, Ohio) was appointed as chair and Ms. Warfield was designated as the NIST Technical Advisor.

NCWM 2011 Interim Meeting: The TG held its first work session, chaired by Ms. Maureen Henzler (Kansas Department of Agriculture). There was discussion on the current forms and types of printer ink. Industry also explained that they are able to deliver less ink with a better print quality. As a result they refrain from using the net content statement but believe that a page yield is more useful information for a consumer in making comparisons. Industry was informed that yield is not acceptable and they cannot use words like “approximate” and “estimated.” It was agreed that yield could be a supplementary statement on the package. The 2011 L&R Committee designated this item as an Informational item.

The TG requested the following additional information from industry:

1. How does the ISO standard work and how does this standard would fit into the weights and measures test procedure?
2. How is print darkness measured?
3. Why have manufacturers removed the net weight declaration from packages and replaced it with a page yield?
4. When changing formulas, is the toner receptacle resubmitted back through the ISO standards to validate the page print accuracy?

NCWM 2011 Annual Meeting: The TG held a Sunday work session. Several state, county, and city weights and measures officials and members of industry attended. Mr. Josh Rosenberg (Information Technology Industry Council [ITI]), and other printer industry representatives gave a presentation outlining why they believe yield is the appropriate method of sale for their products. They responded to questions regarding the quantity control they have when manufacturing the cartridges. All industry representatives acknowledged in response to questions that their companies have very good quantity control systems in place for filling cartridges. A stakeholder stated that packages must have the weight, measure, or count; no other type of labeling is acceptable. Participants commented that “yield” is not an acceptable means of labeling for any product. The TG agreed to meet again at the 2012 NCWM Interim Meeting. The group requested that industry representatives make another presentation at that time that would be limited just to the labeling issue. The TG plans to submit a method of sale proposal to the NCWM L&R Committee for a method of sale for packaged printer ink and toner cartridges.

During the Committee Open Hearings, Mr. Rosenberg (representing Lexmark, Hewlett Packard, Kodak, Epson, and Brother) submitted a presentation from the Sunday session for the record (refer to Appendix C in the *Report of the National Conference on Weights and Measures* [SP 1125, 2011]). Mr. Rosenberg remarked that quantity declarations by volume or weight do not meet the objectives of his organization nor consumers’ preference. He said that yield is the best way to enable consumers to make informed purchase decisions. He believes the ISO standard for yield can be applied to create that data. Mr. Rosenberg stated that industry representatives will attend upcoming regional meetings to address any issues or concerns. A stakeholder noted that he does not believe the ISO yield standard is acceptable, because each manufacturer’s default system is different. He also pointed out that NCWM is not a performance based evaluation agency, and encouraged the Task Group to propose the use of weight or volume as the method of sale. The L&R Committee requested that the TG continue developing this item.

NCWM 2012 Interim Meeting: Ms. Henzler informed the Committee that the TG did not have a recommendation on a method of sale for either the ink or toner. They did suggest minor editorial changes to add the word “copying” after the word “printing” or vice versa, throughout the definitions.

Several members of the ink and toner industry recommended that this item be Withdrawn, and they have reflected this in letters written to the Committee since this item first appeared. They remarked that the current proposal would confuse and mislead consumers. They believe that consumers are not concerned with the net quantity of ink they are getting, but how many pages they can print. They agreed that the definitions do need additional work. They added that there are other ink technologies in the marketplace such as, wax sticks and oils. Currently wax sticks/crayons are sold by count.

A contractor commented that the Method of Sale Regulation states items must be sold on the basis of weight, measure, or count. The regulation should be the starting point with the possibility of adding supplementary information. The Committee believes test procedures need to be developed to test these commodities. In addition, destructive testing of these products can be costly. The Committee wants to look at the possibility for both toner and ink to be sold by weight. Ms. Cardin, TG Chair, will request that the NCWM Board of Directors appoint a new work group to develop test procedures and to disband the current TG on Printer Ink and Toner Cartridges. The 2012 L&R Committee designated this item as an Informational item.

NCWM 2012 Annual Meeting: The new Printer Ink and Toner Cartridge Gravimetric Package Testing Task Group (TG) met to discuss a test method that would require industry to label cartridges with a tare (packaged materials) weight. This TG, chaired by Ms. Cardin, will continue to develop gravimetric test methods for printer ink and toner cartridges, and will provide a report at the 2013 NCWM Interim Meeting. The Committee is placing an item in the 260 Series (NIST Handbook 133) in their next agenda to report the work of the Printer Ink and Toner Cartridge Gravimetric Package Testing TG. The L&R Committee will delay further development of this method of sale item until the TG has completed its recommendations.

NCWM 2013 Interim Meeting: Ms. Cardin (Printer Ink and Toner Cartridge Gravimetric Package Testing TG Chair) provided a presentation on the work of the TG (refer to Item 260-3). Ms. Cardin also provided a marketplace survey that reflected “count” was the most common quantity statement being used. Industry was asked about the feasibility of placing the tare weight on cartridges. Their response was that it was not practicable due to cartridge parts being manufactured domestically and internationally and may not always be made of the same material. The presentation also reflected an in-house test using a gravimetric procedure. The TG concluded that there is not a practical test procedure and the work group is disbanding. The Committee discussed the results of the TG and reviewed the method of sale language. In conclusion, the method of sale language was revised by the L&R Committee to allow for this product to be sold by count. Ms. Lisa Warfield (NIST, OWM) commented that consideration needs to be given to the time manufacturers will need to change over 2013 NCWM Annual Meeting: The Committee heard several comments that there may not be a feasible way to label and test this product. Industry believes that consumers are interested in a yield statement when making a purchase. The Committee modified the language in Section 2.XX.3. Yield Disclosure to read as:

2.XX.3. Yield Disclosure – If the seller discloses the yield of printer ink or toner cartridges on the package, then it shall be measured using the latest version of ISO/IEC printer yield standard on the package offered for prepackaged sale. This information shall be considered a supplemental statement.

The Committee moved this item to an Informational for a review of the amended language at the fall regional association meetings.

NCWM 2014 Interim Meeting: The Committee heard that count should not be the method of sale for this item. If there is a concern, they can use third-party testing laboratories to test against the appropriate ISO/IEC standard. The Committee reviewed the history and regional reports and Withdrew this item.

Regional Association Comments:

CWMA’s L&R Committee feels a feasible way to label and test this product has not been discovered and the item should be Withdrawn. State officials have both supported and opposed this item in the past, some indicating they would rather see a weight statement because the amount of ink would be too small to measure the density. There

has been some support for a yield statement instead of measurement by weight because one cannot measure when the cartridge retains some portion of ink. Others question how yield could be measured (ISO yields are based upon approximations), but suggested yield may be a supplemental declaration. No new procedures or recommendations have been brought forth from the Printer Ink and Toner Cartridge Gravimetric Package Testing TG. This issue has been on the agenda since 2010. CWMA recommended that this item be Withdrawn.

WWMA received comment from a regulator who noted that yield is being considered since no method of sale can be agreed on. If a statement of yield is required, it could be perceived as method of sale, when in fact it is a supplemental performance statement. The Committee noted there was no practical way to verify and measure such quantity statements. During Committee deliberations, it was noted that if yield is agreed upon by NCWM, then the committee's recommendation is to place this requirement in the Uniform Package and Labeling Requirement, Section 11, rather than the Method of Sale. WWMA recommended that this item be Withdrawn.

NEWMA received a presentation at its 2010 Annual Meeting from Mr. Pociask (American Consumer Institute) regarding a lack of consumer information when purchasing computer printers and cartridges. NEWMA expressed that there are still many unanswered questions and would like to hear from manufacturers of printer ink and toner cartridges. NEWMA recommended that the item remain as an Informational item. At the 2010 NEWMA Interim Meeting, it was announced NCWM is seeking a chair for the Printer Ink and Toner Cartridge Task Group. In 2011, there were no comments heard on this item. The Committee Chair reminded members that the Printer Ink and Toner Cartridge TG will be meeting on the Sunday prior to the start of the NCWM Annual Meeting, and that industry will be giving a presentation. The NEWMA L&R Committee recommended that this item move forward as an Informational item. At the 2012 NEWMA Annual Meeting, Mr. Floren (Los Angeles County, California) indicated that there is an impasse on Method of Sale and test procedures on these items. The TG was not planning to meet at this time to resolve the issues. NEWMA recommended that the item remain as an Informational item. At the 2013 NEWMA Annual Meeting, several representatives believed "count" was meaningless. A remark was made about "low count: being exempt from count requirements." NIST responded stating it would be exempt if written into the requirements. FTC was consulted but did not take a position on this issue. Several attendees speaking as consumers voiced concerns on a yield statement. NIST advised that there are ISO/IEC yield standards. NEWMA recommended the modification to Section XX.2. Method of Sale.

2.XX.2. Method of Sale and Labeling.

2.XX.2.1. Method of sale, printer ink cartridges. – All printer ink cartridges kept, offered, or exposed for sale or sold shall be sold in terms of the count

2.XX.2.2. Method of Sale, toner cartridges. – All toner cartridges kept, offered, or exposed for sale or sold shall be sold in terms of the count

2.XX.3. Yield Disclosure. – The seller shall disclose the yield of printer ink or toner cartridges as per ISO/IEC 19752, ISO/IEC 19798, ISO/IEC 24711, ISO/IEC 24712 on the package offered for prepackaged sale, or on the receipt for direct sale, or on the transfer document for bulk sale.

NEWMA stated all work has been completed and industry and NCWM L&R are in agreement on the Method of Sale by count. The proposed modification provides clarity to the consumer when "yield" is questioned. NEWMA recommended the modified language move forward as a Voting item.

NEWMA 2013 Interim Meeting: NEWMA reviewed comments and recommendations for this to be Withdrawn from the WWMA and SWMA. There was a variety of concerns with this item from attendees. The NCWM L&R Committee recommended that method of sale be count. Discussion was heard about the lack of accuracy using weight/volume of the cartridges based on the variety of different parts in ink cartridges and third party manufacturers complying with ISO/IEC yield standards. One attendee did not want this to be Withdrawn, it should not be difficult to determine yield based on ISO/IEC for individual manufacturers. Another attendee stated that yield could be part of secondary package labeling. NEWMA recommends this item be sent to PALS for input on secondary labeling on the packaging in addition to count thereby giving the consumer more information using the 2013 NEWMA proposed yield language as a basis.

SWMA received this proposal at their 2009 Annual Meeting. A Lexmark representative commented they do not believe that a net content statement should be required, and a page yield is sufficient. He read the main points of a Lexmark letter to Mr. Gray, (Florida Department of Agriculture and Consumer Services) dated March 17, 2009. The main points within the letter were: 1) the ink associated with a cartridge is a small fraction of the total cost of the print cartridge mechanism; 2) a page yield can provide a meaningful comparison to a consumer if all manufacturers employ the same estimating assumptions and techniques; and 3) International Organization for Standardization (ISO) studied this issue for years and has rejected reliance on ink volume or quantity; instead ISO has developed a yield estimating and claiming methodology that permits cartridges to be compared using a consistent yardstick. Unlike ink volume measurements, page yield measurements provide a consumer with a reliable way to compare the amount of printing that can be expected. Lexmark also stated ink is expressly exempt from labeling as provided by the FPLA, 16 CFR Part 503.2(a).

An industry representative said this issue does need to be discussed and reviewed further. However, many officials believe consumers should know what they are getting. If it is determined that page count is the quantity statement, then the page print standard should be reviewed and have tighter standards. Mr. Gray said more data is needed from manufacturers on this issue. SWMA forwarded the item to NCWM, recommending it as a Developing item.

SWMA 2010 Annual Meeting: It was announced that a chair is needed for the Printer Ink and Toner Cartridge TG. The Committee did not endorse the formation of the Printer Ink and Toner Cartridge TG to resolve this issue. Only within the past couple years have manufacturers changed their declaration statement to read “yield.” Allowing the declaration by yield will open the door for other commodities to change their labeling (e.g., loads of laundry). The SWMA Committee recommended that these commodities be sold by volume and weight; however, they are not opposed to yield being a supplementary statement. This will allow for inspectors to verify the net contents, and also provide information for consumers to make value comparisons. The Committee would like to seek additional information from industry and ink refillers. SWMA recommended that the item be a Voting item.

SWMA 2011 Annual Meeting: No comments were recorded. The Committee supported the item as written. SWMA recommended that the item be a Voting item.

SWMA 2012 Annual Meeting: An industry representative serving on the Printer Ink and Toner Cartridge Gravimetric Package Testing TG commented that it is was established to develop a test procedure for checking net contents without regard for the method of sale. SWMA supported the Method of Sale proposal as written recommended that the item be a Voting item.

SWMA 2013 Annual Meeting: SWMA recommended the item be Withdrawn since no acceptable resolution appears to be able to be reached.

Additional letters, presentations, and data may have been part of the Committee’s consideration. To review the supporting documentation, please refer to the *Report of the 98th National Conference on Weights and Measures* (SP 1171, 2013).

232-6 V Section 2.30. ~~E85 Fuel~~ Ethanol Flex Fuel Blends

(This item was Adopted.)

Source:

Fuels and Lubricants Subcommittee Task Group (2012)

(Note: In the *Report of the 98th National Conference on Weights and Measures* (2013) Item 232-6)

Purpose:

Update regulations related to flex fuels.

Item under Consideration:

Amend NIST Handbook 130, Method of Sale Regulation as follows:

2.30. ~~E85 Fuel~~ Ethanol Flex Fuel.

2.30.1. How to Identify ~~Fuel-Ethanol Flex Fuel~~ – ~~Fuel-Ethanol flex fuel~~ shall be identified as “ethanol flex fuel or EXX flex fuel” ~~E85.~~

2.30.2. Labeling Requirements.

(a) ~~Fuel Ethanol flex fuel with an ethanol concentration no less than 51 and no greater than 83 volume percent shall be labeled “ethanol flex fuel, minimum 51 % ethanol”. shall be labeled with its automotive fuel rating in accordance with 16 Code of Federal Regulations Part 306.~~
(Amended 2014)

(b) Ethanol flex fuel with an ethanol concentration less than or equal to 50 volume percent shall be labeled “EXX Flex Fuel, minimum YY % ethanol”, where the XX is the target ethanol concentration in volume percent and YY is XX minus 5. The actual ethanol concentration of the fuel shall be XX volume percent plus or minus 5 volume percent.
(Added 2014)

~~(c)(b)~~ A label shall be posted which states “For Use in Flexible Fuel Vehicles (FFV) Only.” This information shall be clearly and conspicuously posed on the upper 50 % of the dispenser front panel in a type at least 12.7 mm (½ in) in height, 1.5 mm (1/16 in) stroke (width of type). A label shall be posted which states, **“CHECK OWNER’S MANUAL,”** ~~“Consult Vehicle Manufacturer Fuel Recommendations,”~~ and shall not be less than 6 mm (¼ in) in height by 0.8 mm (1/32 in) stroke; block style letters and the color shall be in definite contrast to the background color to which it is applied.

(Amended 2014)

(Added 2007) **(Amended 2014)**

Background/Discussion:

The current wording in NIST Handbook 130 related to fuels restricted to use in Flex Fuel Vehicles should be reviewed. Input gathered from the regional meetings and other stakeholders will be used by FALS to develop recommended modifications to NIST Handbook 130.

NCWM 2013 Annual Meeting: Mr. Chuck Corr, Chair of the task group under FALS provided initial language changes for a Section 2.30. E85 Fuel Ethanol. There is additional work being done by this task group under the L&R Committee Item 237-9.

NCWM 2014 Interim Meeting: There was a comment that the language put liability on the retailer and the owner needs to bear the responsibility on what fuel is required. The language presented needs to be clearer to address this issue. The Committee made minor modifications to the language that was provided by the Chair of the TG. The Committee is recommending this modified language move forward as a Voting item.

NCWM 2014 Annual Meeting: FALS informed the Committee that the term “ethanol flex fuel” shall not be capitalized. Matthew Curran, FALS Chair, indicated he is in contact with the Federal Trade Commission (FTC) in regard to the FTC proposed ruling on this issue. Currently, FTC is awaiting the outcome of the 2014 NCWM Annual Meeting results before proceeding (refer to Appendix C) with their proposal. The Committee agreed to modify the language in its Interim Report to that shown in this Final Report in the item Under Consideration.

Regional Association Comments:

Fall 2013 CWMA Meeting: They offered the following revised proposal to improve the handbook wording on gasoline ethanol blends above 15 %. CWMA supported this alternate wording as a Voting item:

2.30. Ethanol Flex Fuel Blends E85 Fuel Ethanol.

2.30.1. How to Identify Ethanol Flex Fuel Blends Fuel Ethanol. – Ethanol Flex Fuel Blends Fuel ethanol shall be identified as Ethanol Flex Fuel or EXX Flex Fuel E85.

2.30.2. Labeling Requirements.

- (a) **Ethanol Flex Fuel blends with an ethanol concentration no less than 51 and no greater than 83 volume percent shall be labeled “Ethanol Flex Fuel, minimum 51 % ethanol”. Fuel ethanol shall be labeled with its automotive fuel rating in accordance with 16 Code of Federal Regulations Part 306.**
- (b) **Ethanol Flex Fuel blends with an ethanol concentration less than or equal to 50 volume percent shall be labeled “EXX Flex Fuel, minimum YY % ethanol”, where the XX is the target ethanol concentration in volume percent and YY is XX minus 5. The actual ethanol concentration of the blend shall be XX volume percent plus or minus 5 volume percent.**
- (c)(b) A label shall be posted which states “For Use in Flexible Fuel Vehicles (FFV) Only.” This information shall be clearly and conspicuously posed on the upper 50 % of the dispenser front panel in a type at least 12.7 mm (½ in) in height, 1.5 mm (1/16 in) stroke (width of type). A label shall be posted which states, **“CHECK OWNER’S MANUAL”, “Consult Vehicle Manufacturer Fuel Recommendations,”** and shall not be less than 6 mm (¼ in) in height by 0.8 mm (1/32 in) stroke; block style letters and the color shall be in definite contrast to the background color to which it is applied.

2014 CWMA Annual Meeting: An industry representative encouraged support of this item; FALS also recommends its adoption. A regulator summarized a recent Notice of Proposed Rule from the FTC. He indicated the proposal falls short in a number of areas: 1) for E15, the only requirement would be an EPA label – the FTC proposal does not require an octane rating; 2) ethanol blends above 15 % to 83 % will be posted in units of 10 percent increments; 3) the term “E85” can no longer be used. A second industry representative commented that the FTC proposal is a regression and creates problems; he urged support for this item. FALS is considering submitting comments to FTC regarding the proposed rule. The CWMA L&R Committee agrees with the comments from regulators and industry, believes the item has been fully developed, and is ready for Voting.

WWMA heard from an industry representative who stated that FALS recommends the item be voted upon with the changes shown in the CWMA 2013 Fall Meeting Item 232-5, Section 2.30.2.(c). WWMA recommended the proposed version above as a Voting item.

NEWMA heard from an industry representative that FALS recommends the item be voted upon with the same changes represented above in the CWMA 2013 Fall Meeting, Item 232-5, Section 2.30.2.(c). NEWMA recommended that the item be a Voting item. 2014 NEWMA Annual Meeting: It was recommended this be a Voting item to make it consistent with ASTM on volatility and Flex Fuel language.

SWMA recommended at its 2013 Annual Meeting that the item be a Voting item on the NCWM agenda with the change from “font size” to a measurable type size in paragraph (c) of the proposal as shown in the CWMA 2013 Fall Meeting report, Item 232-5.

Additional letters, presentations, and data may have been part of the Committee’s consideration. To review the supporting documentation, please refer to the *Report of the 98th National Conference on Weights and Measures* (SP 1171, 2013).

232-7 V Section 2.XX. Diesel Exhaust Fluid (DEF).

(This item was Adopted.)

Source:

American Petroleum Institute (2014)

Purpose:

To include Diesel Exhaust Fluid (DEF) in NIST Handbook 130, including defining DEF and outlining marking requirements to provide information to consumers of DEF.

Item under Consideration:

Amend NIST Handbook 130, Uniform Regulation for the Method of Sale of Commodities as follows:

2.35. Diesel Exhaust Fluid (DEF).

2.35.1. Definition.

2.35.1.1. Diesel Exhaust Fluid. – A preparation of aqueous urea [(NH₂)₂CO], containing 32.5 % by mass of technically-pure urea in high-purity water with quality characteristics defined by the latest version of ISO 22241, “Diesel engines - NO_x reduction agent AUS 32.”

2.35.2. Labeling of Diesel Exhaust Fluid. – Diesel Exhaust Fluid shall be labeled.

2.35.2.1. Retail Dispenser Labeling. – A label shall be clearly and conspicuously placed on the front panel of the Diesel Exhaust Fluid dispenser stating “for operation of selective catalytic reduction (SCR) converters in motor vehicles with diesel engines.”

2.35.2.2. Documentation for Retailers of Bulk Product. – A DEF supplier shall provide, at the time of delivery of the bulk shipment of DEF, identification of the fluid’s origin including the name of the fluid manufacturer, the brand name, trade name, or trademark, and a statement identifying the fluid as DEF conforming to specifications given in the latest version of ISO 22241, “Diesel engines - NO_x reduction agent AUS 32.” This information shall be provided by the supplier on an invoice, bill of lading, shipping paper, or other document.

2.35.2.3. Labeling of Packaged Product. – Any diesel exhaust fluid retail package shall bear a label that includes the name of the fluid manufacturer, the brand name, trade name, or trademark, a statement identifying the fluid as DEF conforming to specifications given in the latest version of ISO 22241 “Diesel engines - NO_x reduction agent AUS 32,” and the statement, “It is recommended to store DEF between – 5 °C to 30 °C (23 °F to 86 °F).”

2.35.2.4. Documentation for Bulk Deliveries. – A carrier that transports or accepts for transportation any bulk shipment by tank truck, freight container, cargo tank, railcar, or any other vehicle used to transport or deliver bulk quantities of DEF shall, at the time of delivery of the DEF, provide identification of the fluid’s origin including the name of the fluid manufacturer, the brand name, trade name, or trademark, and a statement identifying the fluid as DEF conforming to specifications given in the latest version of ISO 22241, “Diesel engines - NO_x reduction agent AUS 32.” This information shall be provided to the recipient on an invoice, bill of lading, shipping paper, or other document.

Effective date shall be January 1, 2016

(Added 2014)

Background/Discussion:

Diesel exhaust fluid (DEF) is an aqueous mixture of 32.5 % high-purity urea and 67.5 % deionized water, and it is used in conjunction with Selective Catalytic Reduction (SCR) systems to remove harmful NO_x emissions from diesel engines. In January 2010, the U.S. Environmental Protection Agency (EPA) enacted new emission standards requiring medium- and heavy-duty diesel vehicles to significantly reduce engine emissions, including NO_x. A majority of engine manufacturers is now using SCR systems to meet the new EPA standards in their diesel applications, and is specifying the use of DEF meeting the quality requirements of the most current version of ISO 22241, “Diesel engines - NO_x reduction agent AUS 32,” Parts 1-5.

As a result, the sale of DEF has become a fast-growth, emerging market as pre-2010 on- and off-highway equipment inventory continues to turn over. For instance, DEF may currently be purchased at fuel-island pumps at over 1000 locations nationwide, with many more locations expected in the near future. The sale of DEF can be expected to continue to grow very quickly as additional fleet turnover occurs and regulations for passenger cars, light-duty trucks, non-road vehicles, and stationary diesel engines are phased in during the coming years. Hence, it is of utmost importance that consumers of DEF are receiving the proper information about the product they purchasing as well as assurances that the product meets the ISO 22241, “Diesel engines - NO_x reduction agent AUS 32,” specifications. The language as originally proposed is as follows:

2.XX. Diesel Exhaust Fluid (DEF).**2.XX.1. Labeling of Diesel Exhaust Fluid. – Diesel Exhaust Fluid shall be labeled.**

2.XX.1.1. Definition. – diesel exhaust fluid, DEF, n—preparation of aqueous urea [(NH₂)₂CO], containing 32.5% by mass of technically pure urea in high-purity water with quality characteristics defined by International Standards Organization’s latest version of ISO 22241. “Diesel engines - NO_x reduction agent AUS 32.”

2.XX.1.2. Marking Requirements. – With the exception of on-vehicle storage tanks designed for use in a vehicle’s emissions control system, any diesel exhaust fluid retail package, storage container, or point-of-sale delivery apparatus, delivery invoice and/or receipt shall contain the following:

2.XX.1.2.1. A statement identifying the fluid as DEF conforming to specifications given in the latest version of ISO 22241.

2.XX.1.2.2. With the exception of point-of-sale delivery apparatus, identification of the fluid’s origin including the name of the fluid manufacturer, brand name, trade name, or trademark, as provided in the latest version of ISO 22241-3.

2.XX.1.2.3. Any diesel exhaust fluid retail package or storage container shall have the following statement, “It is recommended to store DEF between 23 °F to 77 °F (– 5 °C to 25 °C).”

2.XX.1.3. Marking Placement. – Markings on any diesel exhaust fluid retail package or storage container required by 2.XX.1.2. shall be clearly visible, legible and printed on, tagged with, or otherwise affixed to a surface, other than the bottom, of the required package, or container.

2.XX.1.4. Bulk Deliveries. – A carrier that transports or accepts for transportation any bulk shipment by tank truck, freight container, cargo tank, railcar, or any other vehicle used to transport or deliver bulk quantities of DEF is exempt from the labeling requirements of Section 2.XX.1.2. Marking Requirements, provided, however, that the information required by Section 2.XX.1.2. Marking Requirements, appears on the shipment bill of lading or other form of documentation accompanying the shipment.

NCWM 2014 Interim Meeting: A representative with API provided FALS with modified language. This language addresses the regional concerns regarding the clarity of the language and providing for retail dispenser labeling. This modification also expanded the recommended temperature ranges and is consistent with the ISO Method. FALS concurs with the changes and submitted the changes to the Committee recommending it as a Voting item.

NCWM 2014 Annual Meeting: An API representative supported this item and supports a provision for an effective date of January 2016. The Committee agreed to modify the language in its Interim Report to that shown in this Final Report in the Item Under Consideration.

Regional Association Comments:

In the fall of 2013, CWMA forwarded the item to NCWM recommending it as a Voting item. An ISO specification currently exists for this product, and quality assurance is important. At the 2014 CWMA Annual Meeting, the Committee was informed that there is a companion Item 237-10. An industry representative supports both items. A regulator has been working through the ASTM process to develop a specification for this product, but ASTM has decided to not pursue it. Consequently, he urges support and passage of this item. After discussion among the attendees, consensus was reached that an implementation date of one year after passage would allow sufficient time for the regulated industry to comply. The Committee is also recommending a proposed effective date be placed into the item that reflects an effective date of one year after publication. The Committee believes a specification for this product is important, since ASTM is not going to develop a specification, this item should move forward as a Voting item.

WWMA heard from an API representative regarding Items 232-6 and 232-7 simultaneously. The API representative explained there is no definition for DEF. He also stated the sale of DEF will continue to increase in the marketplace, as it is in use on all selective catalytic reduction diesel vehicles. He further stated the method to manufacture DEF may differ, but the standard remains the same for all DEF products and purity is important. The FALS Chairman stated that ASTM does not have a specification, so the ISO specification is appropriate and would recommend this as a Voting item. An industry representative from Gilbarco spoke to whether current receipt technology has the capability to print all required information. An industry representative expressed concern regarding temperatures requirements due to storage locations outside the specified range. The Committee supports this item and would like clarification in regards whether current receipt technology (dispenser) can accommodate proposed requirements. WWMA forwarded this item to NCWM and recommended it as an Informational item.

NEWMA heard a comment from the submitter that adding Diesel Exhaust Fluid (DEF) to NIST Handbook 130, including defining DEF and outlining marking requirements would provide information to consumers of DEF. NEWMA forwarded the item to NCWM, recommending that it be a Developing item. At the 2014 NEWMA Annual Meeting, the Committee believed this item is fully developed and recommended it as a Voting item.

SWMA forwarded the item to NCWM, recommending it as a Developing item to further address the concerns of quality statements on receipts and dispensers.

Additional letters, presentations, and data may have been part of the Committee's consideration. To review the supporting documentation, please refer to the *Report of the 98th National Conference on Weights and Measures* [SP 1171, 2013].

232-8 V Section 2.20. Gasoline-Oxygenate Blends

(This item was Adopted.)

This information was not published within Publication 16, Committee Reports for the 99th Annual Meeting. This item is an editorial change recommended by FALS and approved by the Committee. There is a companion Item 237-7, 3.2.7 Documentation for Dispenser Labeling Purposes.

Source:

Archer Daniels Midland Company (2014)

Purpose:

Update the information for documentation for dispenser labeling purposes in the method of sale section of the *Uniform Regulation of the Method of Sale of Commodities* in NIST Handbook 130. This update will recognize the EPA regulations for product transfer documents for gasoline and gasoline/oxygenate blends.

Item under Consideration:

Amend NIST Handbook 130, Uniform Regulation for the Method of Sale of Commodities as follows:

2.20. Gasoline-Oxygenate Blends.

2.20.1. Method of Retail Sale. – Type of Oxygenate must be Disclosed. – All automotive gasoline or automotive gasoline-oxygenate blends kept, offered, or exposed for sale, or sold at retail containing at least 1.5 mass percent oxygen shall be identified as “with” or “containing” (or similar wording) the predominant oxygenate in the engine fuel. For example, the label may read “contains ethanol” or “with MTBE.” The oxygenate contributing the largest mass percent oxygen to the blend shall be considered the predominant oxygenate. Where mixtures of only ethers are present, the retailer may post the predominant oxygenate followed by the phrase “or other ethers” or alternatively post the phrase “contains MTBE or other ethers.” In addition, gasoline-methanol blend fuels containing more than 0.15 mass percent oxygen from methanol shall be identified as “with” or “containing” methanol. This information shall be posted on the upper 50 % of the dispenser front panel in a position clear and conspicuous from the driver’s position in a type at least 12.7 mm (½ in) in height, 1.5 mm (1/16 in) stroke (width of type).

(Amended 1996)

2.20.2. Documentation for Dispenser Labeling Purposes. – ~~At the time of delivery of the fuel, the retailer shall be provided, on an invoice, bill of lading, shipping paper, or other documentation a declaration of the predominant oxygenate or combination of oxygenates present in concentrations sufficient to yield an oxygen content of at least 1.5 mass percent in the fuel. Where mixtures of only ethers are present, the fuel supplier may identify either the predominant oxygenate in the fuel (i.e., the oxygenate contributing the largest mass percent oxygen) or, alternatively, use the phrase “contains MTBE or other ethers.” In addition, any gasoline containing more than 0.15 mass percent oxygen from methanol shall be identified as “with” or “containing” methanol. This documentation is only for dispenser labeling purposes; it is the responsibility of any potential blender to determine the total oxygen content of the engine fuel before blending.~~ The retailer shall be provided, at the time of delivery of the fuel, on product transfer documents such as an invoice, bill of lading, shipping paper, or other documentation:

- (a) Information that complies with 40 CFR § 80.1503 when the fuel contains ethanol.
- (b) For fuels that do not contain ethanol, information that complies with 40 CFR § 80.1503 and a declaration of the predominant oxygenate or combination of oxygenates present in concentrations sufficient to yield an oxygen content of at least 1.5 mass percent in the fuel. Where mixtures of only ethers are present, the fuel supplier may identify either the predominant oxygenate in the fuel (i.e., the oxygenate contributing the largest mass percent oxygen) or alternatively, use the phrase “contains MTBE or other ethers.”
- (c) Gasoline containing more than 0.15 mass percent oxygen from methanol shall be identified as “with” or “containing” methanol.

(Amended 2014)

(Added 1984) (Amended 1985, 1986, 1991, ~~and~~ 1996, and 2014)

Background/Discussion:

NCWM 2014 Annual Meeting: Mr. Chuck Corr, submitter of this item, informed the Committee that a companion item under the Fuels and Lubricants Regulation, Item 237-7 was submitted and there needs to be a corresponding Method of Sale. The Committee agreed that a method of sale needed to proceed in tandem with Item 237-7.

The proposal incorporates existing EPA regulations.

Additional letters, presentations, and data may have been part of the Committee's consideration. To review the supporting documentation, please refer to the *Report of the 98th National Conference on Weights and Measures* (SP 1171, 2013).

237 NIST HANDBOOK 130 – UNIFORM ENGINE FUELS AND AUTOMOTIVE LUBRICANTS REGULATION

237-1 W Section 1. Definitions - Diesel Liter Equivalent (DLE) and Diesel Gallon Equivalent (DGE)

(This item was Withdrawn.)

Source:

Clean Vehicle Education Foundation (2013)

Purpose:

Enable consumers to make cost and fuel economy comparisons between diesel fuel and natural gas.

Item Under Consideration:

Amend NIST Handbook 130, Engine Fuels and Automotive Lubricants Regulation as follows.

Section 1. Definitions

1.XX. Diesel Liter Equivalent (DLE). – means 0.756 kg of natural gas.
(Added 20XX)

1.XX. Diesel Gallon Equivalent (DGE). – means 2.863 kg (6.312 lb) of natural gas.
(Added 20XX)

Background/Discussion:

The gasoline gallon equivalent (GGE) unit was defined by NCWM in 1994 (refer to Appendix A) to allow users of natural gas vehicles to readily compare costs and fuel economy of light-duty natural gas vehicles with equivalent gasoline powered vehicles. For the medium and heavy duty natural gas vehicles in widespread use today, there is a need to officially define a unit (already in widespread use) allowing a comparison of cost and fuel economy with diesel powered vehicles. Also natural gas sold as a vehicle fuel is sold either as Compressed Natural Gas (CNG) or Liquefied Natural Gas (LNG) and each method of sale is measured in mass. Therefore, the generic term for natural gas is proposed to be used in NIST Handbooks 44 and 130 without the existing term “compressed.” The mathematics justifying the specific quantity (mass) of natural gas in a DLE and DGE is included in Appendix A.

The official definition of a DLE and a DGE will likely provide justification for California, Wisconsin, and any other state to permit retail sales of LNG for heavy-duty vehicles in these convenient units.

2013 NCWM Interim Meeting: A presentation in support of this item was given by Mr. Doug Horne (Clean Vehicle Education Foundation). Several comments were heard regarding the references and databases used to develop the calculations. Concern was expressed with the conversion factors used. A NIST S&T Technical Advisor recommends that L&R and S&T work in a joint session since there is a companion Item 337-1 on the S&T agenda. A collaborative effort between the L&R and S&T Committees will ensure that the proposed equivalent unit is dispensed accurately at the dispenser. Several attendees spoke in support of the collaborative effort. The Committee will request the NCWM Board of Directors create a steering committee that consists of experts and stakeholders to review this proposal. L&R will prepare a list of comments that they would like the Steering Committee to review and address. The L&R Committee recommends this as Informational item.

NCWM 2013 Annual Meeting: The Committee was informed that the Natural Gas Steering Committee chaired by Mahesh Albuquerque would be reviewing this item. At the 2014 NCWM Interim Meeting, Mr. Albuquerque (Chair, National Gas Steering Committee) notified the Committee this item was being withdrawn in its entirety. The submitter of this proposal sent in a modified proposal (Item 237-2) on this subject matter that will be further developed by the Steering Committee.

Regional Association Comments:

2012 CWMA Interim Meeting: A regulatory official commented that there is no standard for Diesel Gallon Equivalent (DGE), and LNG and CNG are being sold in Wisconsin and other states as DGE in order to compete with diesel sales. As a result, a standard is urgently needed. DGE sales are occurring in the marketplace without a standard. The Committee recommended that FALS review the conversion factors for DGE and LGE for accuracy. CWMA supported this item and forwarded the item to NCWM, recommending it as a Voting item.

CWMA 2013 Annual Meeting: It was reported that based on the comments received from a majority of states, the committee does not recommend the proposal as written. (See comments from Item 232-1.) CWMA recommends that this item be a Developing item.

WWMA's L&R Committee recommends that the item be further developed by submitter and amend the existing proposed language. WWMA recommended that the item be a Developing item.

NEWMA reviewed the CWMA comments from 2012. A General Motors representative indicated that there is a lot of discussion on a point of reference. It was commented that both methods of labeling may be required on a dispenser. The labeling issue may create more confusion for the consumer. NEWMA recommended further review by the FALS. NEWMA forwarded the item to NCWM recommending it as an Informational item. In 2013, NEWMA recommended that this item be an Informational item. See comments on Item 232-1.

SWMA recommended at their 2012 Annual Meeting a review by the FALS and forwarded the item to NCWM recommending it as an Informational item. At the 2013 SWMA Annual Meeting the S&T and L&R Committees met in joint session to deliberate on the comments received, with discussion that the two committees should move in tandem and their efforts regarding Natural Gas issues should be harmonized. During that joint session a discussion took place on how to move forward on the Natural Gas items. The Committees received a handout from Mr. Brett Barry (Clean Energy) summarizing Natural Gas Vehicle Fuel DGE proposal. The SWMA recommended the item be Withdrawn from the NCWM agenda as the submitter they would reintroduced to the Conference as two separate items.

Additional letters, presentations, and data may have been part of the Committee's consideration. To review the supporting documentation, please refer to the *Report of the 98th National Conference on Weights and Measures* (SP 1171, 2013).

237-2 V Section 1. Definitions - Diesel Liter Equivalent (DLE) and Diesel Gallon Equivalent (DGE): Compressed Natural Gas, Section 1. Definitions - Diesel Liter Equivalent (DLE) and Diesel Gallon Equivalent (DGE): Liquefied Natural Gas, Section 3.11. Compressed Natural Gas (CNG) and Section 3.12. Liquefied Natural Gas (LNG)

(This item was returned to Committee.)

Source:

Clean Vehicle Education Foundation (2013)

Purpose:

Enable consumers to make cost and fuel economy comparisons between diesel fuel and natural gas.

Item under Consideration:

Amend NIST Handbook 130, Uniform Engine Fuels and Automotive Lubricants Regulation as follows:

Section 1. Definitions

1.XX. Diesel Gallon Equivalent (DGE). – means **6.384 lb of compressed natural gas or 6.059 lb of liquefied natural gas.**

1.XX. Diesel Liter Equivalent (DLE). – means **0.765 kg of compressed natural gas or 0.726 kg of liquefied natural gas.**

1.25. Gasoline Gallon Equivalent (GGE). – **means** 2.567 kg (5.660 lb) of **compressed** natural gas.

1.26. Gasoline Liter Equivalent (GLE). – **means** 0.678 kg (1.495 lb) of **compressed** natural gas.

1.35. Liquefied Natural Gas (LNG). – Natural gas **which is predominantly methane** that has been liquefied at ~~126.1~~ **162** °C (~~-259~~**260** °F) **at 14.696 PSIA** and stored in insulated cryogenic tanks for use as an engine fuel.

Section 3. Classification and Method of Sale of Petroleum Products

3.11. Compressed Natural Gas (CNG).

3.11.1. How Compressed Natural Gas is to be Identified. – For the purposes of this regulation, compressed natural gas shall be identified by the term “Compressed Natural Gas” or “CNG.”

3.11.2. Retail Sales of Compressed Natural Gas Sold as a Vehicle Fuel.

3.11.2.1. Method of Retail Sale. – All CNG kept, offered, or exposed for sale or sold at retail as a vehicle fuel shall be **measured** in terms of **mass, and indicated in** the gasoline liter equivalent (GLE), gasoline gallon equivalent (GGE), **diesel liter equivalent (DLE), or diesel gallon equivalent (DGE) units.**

3.11.2.2. Retail Dispenser Labeling.

3.11.2.2.1. Identification of Product. – Each retail dispenser of CNG shall be labeled as “Compressed Natural Gas.”

3.11.2.2.2. Conversion Factor. – All retail CNG dispensers shall be labeled with the **equivalent** conversion factor in terms of kilograms or pounds. The label shall be permanently and conspicuously displayed on the face of the dispenser and shall have either the statements “1 Gasoline Liter Equivalent (GLE) is **Approximately Equal** to 0.678 kg of Natural Gas” **and** “**1 Diesel Liter Equivalent (DLE) is Approximately Equal to 0.765 kg of Compressed Natural Gas**” or the statements “1 Gasoline Gallon Equivalent (GGE) is **Approximately Equal** to 5.660 lb of **Compressed Natural Gas**” **and** “**1 Diesel Gallon Equivalent (DGE) is Approximately Equal to 6.384 lb of Compressed Natural Gas**” consistent with the method of sale used.

3.11.2.2.3. Pressure. – CNG is dispensed into vehicle fuel containers with working pressures of 20 684 kPa (**3000 psig**), or 24 821 kPa (**3600 psig**). The dispenser shall be labeled 20 684 kPa (**3000 psig**), or 24 821 kPa (**3600 psig**) corresponding to the pressure of the CNG dispensed by each fueling hose.

3.11.2.2.4. NFPA Labeling. – NFPA Labeling requirements also apply. (Refer to NFPA 52.)

3.11.2.2.5. Automotive Fuel Rating. – **CNG automotive fuel shall be labeled with its automotive fuel rating in accordance with 16 CFR Part 309.**

3.11.3. Nozzle Requirements for CNG. – CNG fueling nozzles shall comply with ANSI/AGA/CGA NGV 1.

3.12. Liquefied Natural Gas (LNG).

3.12.1. How Liquefied Natural Gas is to be Identified. – For the purposes of this regulation, liquefied natural gas shall be identified by the term “Liquefied Natural Gas” or “LNG.”

3.12.2. Labeling of Retail Dispensers of Retail Sales of Liquefied Natural Gas Sold as a Vehicle Fuel.

3.12.2.1. Method of Retail Sale. – **All LNG kept, offered, or exposed for sale or sold at retail as a vehicle fuel shall be measured in mass, and indicated in diesel liter equivalent (DLE) or diesel gallon equivalent (DGE) units.**

3.12.2.2. Retail Dispenser Labeling.

3.12.2.2.1. Identification of Product. – Each retail dispenser of LNG shall be labeled as “Liquefied Natural Gas.”

3.12.2.2.2. Conversion Factor. – **All retail LNG dispensers shall be labeled with the equivalent conversion factor in terms of kilograms or pounds. The label shall be permanently and conspicuously displayed on the face of the dispenser and shall have either the statement “1 Diesel Liter Equivalent (DLE) is Approximately Equal to 0.726 kg of Liquefied Natural Gas” or “1 Diesel Gallon Equivalent (DGE) is Approximately Equal to 6.059 lb of Liquefied Natural Gas” consistent with the method of sale used.**

3.12.2.2.3. Automotive Fuel Rating. – LNG automotive fuel shall be labeled with its automotive fuel rating in accordance with 16 CFR Part 306.

3.12.2.2.4. NFPA Labeling. – NFPA Labeling requirements also apply. (Refer to NFPA 52.)

Background/Discussion:

The gasoline gallon equivalent (GGE) unit was defined by NCWM in 1994 (refer to Appendix A) to allow users of natural gas vehicles to readily compare costs and fuel economy of light-duty compressed natural gas vehicles with equivalent gasoline powered vehicles. For the medium and heavy duty natural gas vehicles in widespread use today, there is a need to officially define a unit (already in widespread use) allowing a comparison of cost and fuel economy with diesel powered vehicles. The submitter stated that the official definition of a DLE and a DGE will likely provide justification for California, Wisconsin, and many other states to permit retail sales of CNG for heavy-duty vehicles in these convenient units. The mathematics justifying the specific quantity (mass) of compressed natural gas in a DLE and DGE is included in the Appendix.

NCWM 2014 Interim Meeting: Mr. Albuquerque (Chair, National Gas Steering Committee) notified the Committee that this item was actively being developed by the National Gas Steering Committee (NGSC).

The L&R Committee is responded to the NGSC’s June 10, 2014, request to change the NGSC’s March 2014 recommendation for DGE units.

The L&R Committee agreed that the CNG and LNG conversion factors proposed for use in converting these gases to DGE units should be revised in the 2014 Interim Report so that their numerical values are expressed to three decimal places rather than two decimal places. These changes are reflected in the following proposed modifications to Section 1. Definitions 1.XX, and to the proposed new definition for “diesel gallon equivalent” to read “1 Diesel Gallon Equivalent (DGE) is ~~6.380~~ 6.384 pounds of Compressed Natural Gas and 1 Diesel Gallon Equivalent of Liquefied Natural Gas is ~~6.060~~ 6.059 pounds.”

NCWM 2014 Annual Meeting: A joint session was held with L&R and S&T Committees to hear this item. It was noted that if the Committee did not move Item 232-3 forward then there would be no reason to proceed with Item 237-2 and S&T Committee Item 337-2. There was discussion regarding the term “approximately equal” found in Sections 2.27.2.2. and 2.27.2.4. It was noted this term was not a measurement equivalency but refers to energy content. It was recommended that the Committee give consideration to amend the definition and clarify the meaning. Some spoke in opposition that this item would cause consumer confusion in the marketplace, if adopted. Several members questioned where the IRS obtained the numbers that are used in the IRS tax form. NIST provided an alternative proposal to this item, and several members believed this proposal should be taken into consideration. Since the proposal from the NGSC was not released until June 10, 2014, members felt they did not have enough time to vet the modification or the NIST proposal. The Committee reviewed numerous letters in support of all the items that related to the sale of natural gas as vehicle fuel.

March 2014 Natural Gas Steering Committee Report to the L&R and S&T Committees

The Natural Gas Steering Committee (NGSC) was formed in July 2013 to help understand and educate the NCWM membership regarding the technical issues surrounding the proposed changes to NIST Handbooks 44 and 130 submitted by the Clean Vehicle Education Foundation (CVEF), the anticipated impact of the proposed changes, and issues related to implementation requirements when compressed natural gas (CNG) and liquefied natural gas (LNG) are dispensed and sold as a retail engine fuel in gallon equivalent units.

NCWM 2014 Interim Meeting: Mr. Albuquerque, Chair of the NGSC provided the S&T and L&R Committees with an update from the NGSC, including proposed revisions to the proposals submitted by the CVEF. The NGSC heard comments from the floor related to the proposed revisions and requested additional time to further develop its recommendations. The S&T and L&R Committees agreed to allow the NGSC additional time to meet and develop alternative proposals to those on the S&T and L&R Committees January 2014 agendas, with the expectation that the NGSC recommendations would be ready for inclusion in Publication 16, and moved forward as a Voting item at the July 2014 NCWM Annual Meeting.

Summary of NGSC Meeting Discussions

The NGSC met weekly following the January 2014 Interim Meeting, and focused on modifying the Clean Vehicle Education Foundation (CVEF) 2013 proposals for the recognition of diesel gallon equivalent (DGE) units for CNG/LNG dispenser indications and the method of sale for these two natural gas alternative engine fuels. The NGSC reviewed multiple modifications to those proposals including:

- limiting sales to a single unit of mass measurement enforceable by 2016;
- requiring indications in mass and gasoline and diesel gallon equivalents, while phasing in mass only units;
- require sale by mass as the primary means, but allow for the simultaneous display of volume equivalent units, so long as the purchaser always had access to the mass (traceable) measurement; and
- a proposal from NIST OWM which would allow the posting of supplemental information to assist consumers in making value comparisons and for use by taxation/other agencies, but requiring the phase in of indications in mass.

The NGSC received:

- input from DOE on the latest edition of the *DOE Transportation Energy Data Book: Edition 32*, July 2013 available on the Oak Ridge National Laboratory website at: <http://cta.ornl.gov/data/index.shtml>;
- updates from CNG (3) and LNG (1) dispenser manufacturers indicating their dispensing systems comply with the requirements in the handbooks, and have the capability to indicate a sale in a single unit of measurement, and any further input on adding displays to the cabinet for additional units would require further cost analysis; while one OEM indicated use of their LNG RMFD in a fleet operation where indications are only in the DGE; and
- feedback from committee members related to the pros and cons of requiring the indication of sale in mass or gallon equivalent units, including traceability, equipment capabilities, marketplace considerations, and units used by state and federal agencies.

Also noted in the NGSC discussions were:

- how a gallon equivalent unit is derived using energy content, and that the gallon equivalent is defined and measured in terms of mass, not volume;
- for the last 20 years, NIST Handbooks 44 and 130 have required all dispensing equipment to indicate deliveries of natural gas in GGE units to consumers, and in mass units for inspection and testing purposes. CNG RMFD equipment in the most states comply with the requirements in the handbooks;
- international practices for indicating CNG and LNG engine fuel deliveries are predominantly mass; Canada requires LNG indications in the kilogram and the corresponding OIML R 139 “Compressed gaseous fuel measuring systems for vehicles” standard requires indication of the measured gas in mass;
- the variations in engine efficiency relative to a single conversion factor based on an averaged energy content for LNG and the primary focus of the driving public and fleets on mileage rather than petroleum products no longer used to fuel their vehicles;
- the work ahead over the next year by ASTM committees to develop current CNG and LNG fuel quality standards which will need to be referenced in NIST Handbook 130;
- differences in the measurement of the gallon and kilogram – since the gallon is a volume measurement and not an energy measurement, and the NIST Handbook 44 Mass Flow Meters Code includes a requirement for volume-measuring devices with ATC used in natural gas applications to be equipped with an automatic means to make corrections; if the device is affected by changes in the properties of the product, it was also noted that U.S. gasoline and diesel dispensers are not required to have ATC; whereas, ATC does occur in sales at the wholesale level;
- how traceability applies to the measurement results at each level of the custody chain (to include the determination of the uncertainty of all calibrations and use of an appropriate unit of measurement); and
- the capabilities of equipment in the marketplace.

A DOE representative supported the use of gallon equivalents, and pointed out that they are used in the *DOE Transportation Energy Data Book*. The DOE representative also pointed out that other federal agencies including the IRS were requiring use of gallon equivalent units for reporting.

Industry representatives on the NGSC indicated that they are actively campaigning to their state and federal offices, encouraging each government branch to recognize sales of CNG and LNG in gasoline and diesel volume equivalent units. Industry sectors represented on the NGSC indicated that their customers are satisfied with the averaged fuel energy values that correspond to the conversion factors for CNG and LNG, with only one exception. The exception was a truck stop chain indicating their customers would be amenable to a single conversion factor for both fuels. The CVEF also provided a comparison of GTI’s 1992 study results and preliminary data from a 2013 study. The CVEF reported the constituents in natural gas as basically unchanged over 21 years since the NCWM first recognized the GGE. Industry unanimously opposed a recommendation for phasing in mass as the only unit of measurement, noting also that U.S. drivers would be confused by SI units while acknowledging that the United States is in the minority of countries whereby delivery and sales are by equivalent units. At the conclusion of the NGSC deliberations, NGVAmerica provided the following statement:

“One of the major advantages of the proposal as currently drafted with inclusion of the DGE and GGE units for natural gas is that this is a proposal that the natural gas industry can support. It further recognizes what is already the preferred practice for how natural gas is measured and dispensed. The latest proposal with DGE and GGE units provides a pathway forward toward a national consensus approach. If the proposal were to instead require use of kilograms or even pounds as the primary method of sale, industry would not support that proposal and likely would strongly oppose it this summer if NCWM were to consider it as a voting issue. Also, if NCWM finalizes on a standard that does not include DGE or GGE, industry is committed to pursuing adoption of an alternative standard on a state by state basis, which could lead to different treatment across the country. Several states have already introduced legislation to recognize the DGE standard (CA, IL, MO, and VA) and I expect more will do so later this year. And you know Colorado and Arkansas already have put in place standards that recognize the DGE units.”

NGSC Recommendations:

After consideration of all of the above, the NGSC recommends alternate proposals to the L&R and S&T Committee Agenda items which further modify and consolidate the Clean Vehicle Education Foundation 2013 proposals to include:

1. requirements for measurement in mass and indication in gallon equivalent units (NIST Handbook 44 paragraphs S.1.3.1.1. and S.1.3.1.2.; and NIST Handbook 130 paragraphs 3.11.2.1. and 3.12.2.1.);
2. posting of a label that has both the GGE and DGE or the GLE and DLE for CNG applications (NIST Handbook 44 paragraphs S.5.2., S.5.3., UR.3.1.1., and UR.3.1.2; and NIST Handbook 130 paragraphs 3.11.2.2.2. and 3.12.2.2.2.);
3. expression of all equivalent conversion factors expressed in mass units to 3 significant places beyond the decimal point for consistency (NIST Handbook 44 paragraphs S.5.2., S.5.3., UR.3.1.1., and UR.3.1.2 and Appendix D and NIST Handbook 130 Section 1, paragraphs 3.11.2.2.2. and 3.12.2.2.2.);
4. correction of the temperatures in the LNG definition (NIST Handbook 130 Section 1);
5. addition of 16 CFR Part 309 for CNG automotive fuel rating (NIST Handbook 130 paragraph 3.11.2.2.5.); and
6. reference to NFPA 52 (NIST Handbook 130 paragraph 3.12.2.2.4.).

With regards to NIST Handbook 44, the NGSC recommends withdrawing S&T Agenda Items 337-1 and 337-4 and the consolidation of agenda Items 337-2, 337-3, and 337-5 into a newly revised single Voting item designated as Item 337-2. The NGSC also recommends further modifications to corresponding NIST Handbook 130 proposals to align the definitions of related terms and method of sale with definitions, indicated delivery and dispenser labeling requirements being proposed for NIST Handbook 44.

With regards to NIST Handbook 44, the NGSC also recommends consideration of a new Developing item addressing proposed changes to paragraph S.3.6. Automatic Density Correction designated as Item 360-4. This new proposal is consistent with the NGSC decision to encourage further work beyond the current scope of their work on the CVEF's proposals to fully address all LNG applications.

Representatives of the NGSC and the S&T and L&R Committees met in March 2014, all agreed on the course of action outlined above.

Additional Contacts: Clean Energy, Seal Beach, CA, NGV America, Washington, DC, Clean Vehicle Education Foundation, Acworth, GA. Regional Association Comments: (Fall 2013 Input on the Committee's 2014 Interim Agenda Items 337-1 through 337-5).

With regards to NIST Handbook 130 the NGSC recommends withdrawing L&R agenda Item 237-1 and the consolidation of agenda Items 237-2, 237-3, and 237-5 into newly revised single Voting item designated as Item 237-1 of this report.

Regional Association Comments:

2014 CWMA Interim Meeting: Comments were made that this item is a duplicate of Item 237-1 with the exception of the conversion factors, which need to be updated in Item 237-1. Based on this, the Committee recommends this item to be Withdrawn. CWMA did not forward this item to NCWM.

2014 CWMA Annual Meeting: The Committee heard comments on this item in conjunction with Item 237-2 and S&T Item 337-2. Main points included in the testimony included: an industry representative stated that gaining consensus on these proposals provides the best chance to develop a uniform national standard. Currently, there are legislative bills in six states supporting DGEs and similar activity in many other states including a letter of support with 54 signatures from Congress. An industry representative commented his membership supports the concept, but expressed concern over a discrepancy with equivalencies between the Internal Revenue Service (IRS) definition (126.67 cu ft per gal) and the steering group's proposal (123 cu ft gal). He expressed concern that the industry feels these differences must be reconciled, or they will be faced with confusion between the two standards. A second

industry representative agreed. A regulator, who served on the steering group, commented that some members of the steering group attempted to allow for dual declarations on dispensers, using the mass standard as the primary value. He fears adding multiple new standards will add to the confusion. He further stated he had no objection to supplemental language, but traditional mass unit should be the primary unit.

A NIST Technical Advisor commented there are currently seven different types of fuels; and asked if they should all have gasoline gallon equivalents. A parallel example was provided of selling paint on a square foot wall coverage equivalent. Would weights and measures consider it a viable method of sale?

An industry representative commented that multiple unit pricings could cause confusion, and there were concerns about retrofitting old equipment to allow for multiple unit pricings. He further stated labels are the mechanism by which we convey mass measurement. This same industry representative commented that some say GGE should have never been adopted. He asked the Conference how they thought it had not worked in the marketplace. Another regulator stated that natural gas engines are not diesel engines. When posting price equivalence, consumers could be misled or confused as to the energy comparison versus the price comparison.

A NIST representative stated a consumer should be aware of what is being measured, and the measure be accurate. A regulator asked the Conference to recall consideration of equity and uniformity statements in the past. He gave examples of previous items that were artificial declarations and were rejected by the Conference. Examples included “lasts the same as,” “burns longer than,” “equivalent to...etcetera.” A regulator stated in most cases, natural gas has been sold in fleets, so the cost per mile factor has been calculated internally. Sales are now increasing at public fueling locations, so when selling fuel with equivalencies, we are getting into marketing rather than weights and measures functions.

CWMA L&R and S&T Committees met jointly in a working session, and concur the items have merit, but questions and concerns over accuracy of this final proposal still remain. Both Committees agreed to move the item forward as an Informational item. During the L&R Committee’s work session, discussion took place regarding the inconsistency in language in the method of sale in L&R Item 232-3, Section 2.27.2. compared to the method of sale with L&R Item 237-2, Section 3.11.2.1. Additionally, the Committee discussed the importance of including the same number of significant digits in the conversions specified in the DGE and DLE equivalent values. The Chairman of the CWMA L&R Committee will communicate these two concerns to the Chairman of the NCWM Natural Gas Steering Committee.

WWMA reported that two regulatory officials voiced support for method of sale by mass and see no value in using equivalents. The Committee recommends this item be Withdrawn and for the submitter to incorporate the pertinent information into Item 237-1. WWMA did not forward this item to NCWM.

2014 NEWMA Annual Meeting: The Committee heard comments on this item in conjunction with S&T Item 337-2. There was a lot of good discussion on the item with numerous comments from both industry and regulatory officials. A summary of the comments are as follows:

- GGE and GLE are already established measurements in the marketplace for CNG.
- If the product is measured in mass, it should be sold in mass.
- Equivalents are not an exact number.
- Consumers have done homework before they buy.
- There’s wide support from industry to expand GGE to other fuels.
- CNG is taxed at the federal level based on gallon equivalent. It would be easier to tax by GGE.
- All the reasons heard in support of selling by equivalent units sound like marketing tools.
- NIST Handbook 130 is not a promotional tool! It is about the best way to measure.
- Some states have already adopted GGE or DGE as a method of sale for these alternative fuels.

- Clarify method of sale Section 2.27.2.1. to be consistent with Item 237-2; measured in mass and sold by volume.

Additional comments were heard during the S&T Committee Open Hearings suggesting the need to include the same number of significant digits in the conversions specified in the proposal for DGE and DLE values. For example, 6.380 and 6.060 contain four significant digits, whereas, 0.765 and 0.726 contain only three significant digits. A recommendation was made to the Committee that it determines whether or not the values specified are appropriate.

Due to the concerns expressed during the open hearings for both L&R and S&T Committees, NEWMA voted to recommend to the NCWM L&R and S&T Committees the status on the agenda items be changed to Informational.

SWMA recommended review by the FALS at the 2012 Annual Meeting and forwarded the item to NCWM, recommending it as an Informational item. At the 2013 SWMA Annual Meeting, the S&T and L&R Committees met in joint session to deliberate on the comments received, with discussion that the two Committees should move in tandem and their efforts regarding natural gas issues should be harmonized. During the joint session, discussion took place on how to move forward on the natural gas items. The Committees received a handout from Mr. Brett Barry (Clean Energy) summarizing Natural Gas Vehicle Fuel DGE proposal. The SWMA recommended the item be Withdrawn from the NCWM agenda as the submitter indicated it would be reintroduced as two separate items.

Additional letters, presentations, and data may have been part of the Committee's consideration. To review the supporting documentation, please refer to the *Report of the 98th National Conference on Weights and Measures* (SP 1171, 2013).

237-3 W Section 1. Definitions - Diesel Liter Equivalent (DLE) and Diesel Gallon Equivalent (DGE): Liquefied Natural Gas

(This item was Withdrawn.)

Source:

Clean Vehicle Education Foundation (2014)

Purpose:

Since liquefied natural gas (LNG) is sold in the retail market place as an alternative fuel to diesel fuel, the proposed additions and edits to NIST Handbook 44 will provide definitions for liquefied natural gas (LNG) equivalents for diesel liters and gallons so that end users can readily compare cost and fuel economy. At present no LNG equivalents for diesel are included in the handbooks.

Item under Consideration:

Amend NIST Handbook 130, Uniform Engine Fuels and Automotive Lubricants Regulation as follows:

Section 1. Definitions

1.XX. Diesel Liter Equivalent (DLE). – Means 0.7263 kg of liquefied natural gas.

1.XX. Diesel Gallon Equivalent (DGE). – Means 2.749 kg (6.06 lb) of liquefied natural gas.

Background/Discussion:

The gasoline gallon equivalent (GGE) unit was defined by NCWM in 1994 to allow users of compressed natural gas vehicles to readily compare costs and fuel economy of light-duty compressed natural gas vehicles with equivalent gasoline powered vehicles. For the medium and heavy duty liquefied natural gas (LNG) vehicles in widespread use today, there is a need to officially define a unit (already in widespread use) allowing a comparison of cost and fuel economy with diesel powered vehicles. The submitter stated that the official definition of a DLE and a DGE will likely provide justification for California, Wisconsin, and many other states to permit retail sales of LNG for heavy-

duty vehicles in these convenient units. The mathematics justifying the specific quantity (mass) of liquefied natural gas in a DLE and DGE is included in Appendix A.

NCWM 2014 Interim Meeting: Mr. Albuquerque (Chair, National Gas Steering Committee) notified the Committee that this item was being further reviewed by the National Gas Steering Committee. This item was subsequently Withdrawn and combined with Item 237-2.

Regional Association Comments:

CWMA reported that based on the comments received from a majority of states, the committee does not recommend the proposal as written. (See comments from Item 232-1.) CWMA forwarded this item to NCWM and recommended it as a Developing item.

WWMA's L&R Committee recommends this item be Withdrawn and the submitter to incorporate the pertinent information into Item 237-1. WWMA did not forward this item to NCWM.

NEWMA forwarded this item to NCWM and recommended that it be an Informational item. See comments on Item 232-1.

SWMA comments were in favor of moving the definitions forward. The S&T and L&R Committees met in joint session to deliberate on the comments with discussion that the two items should be harmonized and move in tandem. During the joint session, discussion took place on how to move forward on the Natural Gas items. The Committees received a handout from Mr. Brett Barry (Clean Energy) summarizing the Natural Gas Vehicle Fuel DGE proposal that contained current conversions. The SWMA is recommending it be an Informational item.

Additional letters, presentations, and data may have been part of the Committee's consideration. To review the supporting documentation, please refer to the *Report of the 98th National Conference on Weights and Measures* [SP 1171, 2013].

237-4 I Sections 2.1.3. Minimum Antiknock Index (AKI), Section 2.1.4. Minimum Motor Octane Number, and Section 3.2.5 Prohibition of Terms – Table 1.

Source:

General Motors (2013)

Purpose:

Remove obsolete Altitude De-rating of Octane practice, establish a National Octane Baseline, and harmonize Octane Labeling from state to state.

Item Under Consideration:

Amend the NIST Handbook 130, Engine Fuels and Automotive Lubricants Regulation as follows:

Section 2. Standard Fuel Specification

2.1.3. Minimum Antiknock Index (AKI). – The AKI of gasoline and gasoline-oxygenate blends shall not be less than 87. The AKI shall not be less than the AKI posted on the product dispenser or as certified on the invoice, bill of lading, shipping paper, or other documentation.

(Amended 20XX)

2.1.4. Minimum Motor Octane Number. – The minimum motor octane number shall not be less than 82. ~~for gasoline with an AKI of 87 or greater;~~

(Amended 20XX)

Section 3. Classification and Method of Sale of Petroleum Products

3.2. Automotive Gasoline and Automotive Gasoline-Oxygenate Blends

3.2.5. Prohibition of Terms. – It is prohibited to use specific terms to describe a grade of gasoline or gasoline-oxygenate blend unless it meets the minimum antiknock index requirement shown in Table 1. Minimum Antiknock Index Requirements.

Table 1. Minimum Antiknock Index Requirements		
Term	Minimum Antiknock Index	
	ASTM D4814 Altitude Reduction Areas IV and V	All Other ASTM D4814 Areas
Premium, Super, Supreme, High Test	90	91
Midgrade, Plus	87	89
Regular Leaded	86	88
Regular, Unleaded (alone)	85	87
Economy	–	86

(Table 1. Amended 1997 and 20XX)

Background/Discussion:

These NIST Handbook 130 octane changes will harmonize with an effort underway in the ASTM International (ASTM) Gasoline and Oxygenates Subcommittee to include a minimum motor octane number (MON) performance limit in gasoline. The naming of the various octanes is a function for weights and measures.

Nominally, vehicles manufactured after 1984 include engine computer controls maintaining optimal performance while using gasoline octane of 87-AKI or higher. The practice of altitude de-rating of octane, resulting in octanes below 87-AKI, reduces a vehicle's efficiency and fuel economy. Increasingly, more vehicles are boosted (turbocharged/supercharged) eliminating altitude intake air effects. Additionally, consumers using gasoline with an octane AKI below 87 will void their vehicle owner's warranty. The Coordinating Research Council (CRC) Report No. 660, "*Fuel Anti-knock Quality – Engine Response to RON (Research Octane Number) versus MON*," May 2011 demonstrates the continued need for gasoline MON octane for the large bored, naturally aspirated U.S. engines. Setting an 82-MON minimum maintains the current MON level for today's 87-AKI Regular Unleaded gasoline. A common U.S. octane specification between ASTM, NCWM, and Vehicle Owners Manuals will give states clear direction on how best to enforce proper fuel pump octane labeling and quality levels on behalf of vehicle consumers.

Leaded gasoline is not available at retail and therefore labeling guidance is not needed.

NCWM 2013 Interim Meeting: The FALS could not reach agreement on this item during their Sunday work session. The Committee received and reviewed several letters in support of this proposal. During open hearings Mr. Bill Studzinski (General Motors) provided a presentation. The Committee also received comments in opposition to the proposal citing the lack of consumer complaints with sub-octane and it was requested that the Committee wait until the CRC study provides data that can be used by ASTM and NCWM to determine whether or not a change is necessary. The Committee recommends this to be an Informational item.

NCWM 2013 Annual Meeting: Mr. Hayes, FALS Chair provided a presentation and stated that the CRC study has been expanded and finalized data is expected by year end. It was also noted the ASTM ballot failed. The Committee concurs to await a recommendation from FALS once they have considered all the data. Additional letters, presentations, and data may have been part of the Committee's consideration.

NCWM 2014 Interim Meeting: Mr. Studzinski provided an update that the CRC study is almost finalized and then a ballot will be prepared for ASTM. Mr. Studzinski will have additional information for the 2015 NCWM Interim.

NCWM 2014 Annual Meeting: Mr. Curran, FALS Chair, remarked FALS is recommending this as an Informational item until the CRC study results are available. Mr. Studzinski provided a briefing of the work being done and a full report should be issued in the fall of 2014.

Regional Association Comments:

2013 CWMA's L&R Committee recommended this remain Informational pending receipt of additional data from the CRC study. At past meetings, the region has recommended this item be Voting in one instance, but more recently, have recommended it be Informational pending the outcome of the June 2013 ASTM ballot, which is related to octane. A regulatory official requested it be made clear that this would only apply to retail fuel sales. At the 2014 CWMA Annual Meeting, an industry representative commented that General Motors is conducting a study under the Coordinating Research Council (CRC) umbrella at altitude and sea levels analyzing fuel economy and emissions. The item should be balloted by ASTM in September and will be voted on at the December ASTM meeting. Additional information will be provided at the 2015 NCWM Interim meeting. The CWMA L&R Committee believes the item should remain Informational until the CRC results are finalized.

WWMA received comment from the FALS Chairman that the work group is addressing this issue and awaiting results from the CRC study in conjunction with ASTM, which is expected to be released in December 2013. FALS and one regulatory official support this item pending validation from the CRC study. One regulatory official strongly opposed this item due to significant potential negative economic impacts in his and other Rocky Mountain States. He suggested a ten year phase in period. WWMA recommended that this item be an Informational item.

In NEWMA 2012 received a presentation from Mr. Bill Studzinski (GM) summarizing the position of all the regions. NEWMA forwarded the item to NCWM recommending it as a Voting item. At NEWMA's 2013 Annual Meeting, they recommended the item remain Informational until FALS makes a recommendation to the Committee. At the 2013 NEWMA Interim Meeting, NEWMA members indicated that they would like to see the results of the CCR study and a FALS recommendation. NEWMA recommended that the item be an Informational item. At the 2014 NEWMA Annual Meeting, they are awaiting results from the CRC study and recommended this be an Informational item.

SWMA reported in 2012 that Mr. Studzinski (GM, Chair of a FALS Task Group, and ASTM) provided a presentation in support of this item at the 2012 SWMA Annual Meeting. The SWMA Committee acknowledged strong support from their Association. SWMA forwarded the item to NCWM recommending it as a Voting item. At the 2013 SWMA Annual Meeting, the Association supported this item remaining on the agenda as an Informational item pending a recommendation from FALS.

Additional letters, presentations, and data may have been part of the Committee's consideration. To review the supporting documentation, please refer to the *Report of the 98th National Conference on Weights and Measures* [SP 1171, 2013].

237-5 W Section 3.11. Compressed Natural Gas (CNG) and Section 3.12. Liquefied Natural Gas (LNG)

(This item was Withdrawn.)

Source:

Clean Vehicle Education Foundation (2014)

Purpose:

Since natural gas is sold in the retail market place as compressed natural gas (CNG) to be an alternative fuel to gasoline and diesel fuel and as liquefied natural gas (LNG) to be an alternative fuel to diesel, the proposed additions and edits to NIST Handbook 130 will provide definitions for natural gas equivalents for diesel liters and diesel

gallons so that end users can readily compare cost and fuel economy. At present, only CNG equivalents for gasoline are included in the handbooks.

Item under Consideration:

Amend NIST Handbook 130, Uniform Engine Fuels and Automotive Lubricants Regulation as follows:

3.11. Compressed Natural Gas (CNG)

3.11.2.1. Method of retail Sale. – All CNG kept, offered, or exposed for sale or sold at retail as a vehicle fuel shall be either in terms of: ~~the gasoline liter equivalent (GLE) or gasoline gallon equivalent (GGE);~~

(a) Mass (in pounds or kilograms), or

(b) The gasoline liter equivalent (GLE) or gasoline gallon equivalent (GGE); or

(c) The diesel liter equivalent (DLE) or diesel gallon equivalent (DGE).

3.11.2.2. Retail Dispenser Labeling.

3.11.2.2.1. Identification of Product. – Each retail dispenser of CNG shall be labeled as “Compressed Natural Gas.”

3.11.2.2.2. Conversion Factor. – All retail CNG dispensers shall be labeled with the conversion factor in terms of kilograms or pounds. The label shall be permanently and conspicuously displayed on the face of the dispenser and shall have ~~either the statement: “1 Gasoline Liter Equivalent (GLE) is equal to 0.678 kg of Natural Gas” or “1 Gasoline Gallon Equivalent (GGE) is equal to 5.660 lb of Natural Gas” consistent with the method of sale used.~~

(a) either the statement “1 Gasoline Liter Equivalent (GLE) is equal to 0.678 kg of Compressed Natural Gas” or “1 Gasoline Gallon Equivalent (GGE) is equal to 5.660 lb of Compressed Natural Gas” consistent with the method of sale used; or

(b) either the statement “1 Diesel Liter Equivalent (DLE) is equal to 0.765 kg of Compressed Natural Gas” or “1 Diesel Gallon Equivalent (GGE) is equal to 6.38 lb of Compressed Natural Gas” consistent with the method of sale used.

3.11.2.2.3. Pressure. – CNG is dispensed into vehicle fuel containers with working pressures of ~~16 574 kPa~~, 20 684 kPa (3000 psig) or 24 821 kPa (3600 psig). The dispenser shall be labeled ~~16 574 kPa~~, 20 684 kPa (3000 psig) or 24 821 kPa (3600 psig) corresponding to the pressure of the CNG dispensed by each fueling hose.

3.11.2.2.4. NFPA Labeling. – NFPA Labeling requirements also apply. (Refer to NFPA 52.)

3.12. Liquefied Natural Gas (LNG).

3.12.1. How Liquefied Natural Gas is to be Identified. – For the purposes of this regulation, liquefied natural gas shall be identified by the term “Liquefied Natural Gas” or “LNG.”

3.12.2. Labeling of Retail Dispensers of Liquefied Natural Gas Sold as a Vehicle Fuel.

3.12.2.1. Identification of Product. – Each retail dispenser of LNG shall be labeled as “Liquefied Natural Gas.”

3.12.2.2. Automotive Fuel Rating. – LNG automotive fuel shall be labeled with its automotive fuel rating in accordance with 16 CFR Part 306.

3.12.X.X. Method of Retail Sale. – All LNG kept, offered, or exposed for sale or sold at retail as a vehicle fuel shall be in terms of:

(a) mass (in pounds or kilograms); or

(b) the diesel liter equivalent (DLE) or diesel gallon equivalent (DGE).

(Added 20XX)

3.12.2.3. NFPA Labeling. – NFPA Labeling requirements also apply. (Refer to NFPA ~~57-52~~)

(Amended 20XX)

3.12.2.4. Conversion Factor. – All retail LNG dispensers shall be labeled with the conversion factor in terms of kilograms or pounds. The label shall be permanently and conspicuously displayed on the face of the dispenser and shall have:

(a) either the statement “1 Diesel Liter Equivalent (DLE) is equal to 0.7263 kg of Liquefied Natural Gas”; or

(b) “1 Diesel Gallon Equivalent (GGE) is equal to 6.06 lb of Liquefied Natural Gas” consistent with the method of sale used.

(Added 20XX)

Background/Discussion:

The gasoline gallon equivalent (GGE) unit was defined by NCWM in 1994 (refer to Appendix A) to allow users of compressed natural gas (CNG) vehicles to readily compare costs and fuel economy of light-duty natural gas vehicles with equivalent gasoline powered vehicles. For the medium and heavy duty natural gas vehicles in widespread use today, there is a need to officially define a unit for both CNG and LNG (already in widespread use) allowing a comparison of cost and fuel economy with diesel powered vehicles. Natural gas is sold as a vehicle fuel as either CNG or LNG and each method of sale is measured in mass. The submitter stated that the official definition of a DLE and a DGE will likely provide justification for California, Wisconsin, and many other states to permit retail sales of LNG for heavy-duty vehicles in these convenient units. The mathematics justifying the specific quantity (mass) of natural gas in a DLE and DGE is included in the Appendix A.

CNG is no longer dispensed at 16 574 kPa (2400 psig) in the United States so the requirement is no longer valid.

NFPA 57 was incorporate into NFPA 52 in 2006 and is no longer a stand alone document.

At the 2014 NCWM Interim Meeting, Mr. Albuquerque (Chair, National Gas Steering Committee) notified the Committee was developing this item and would provide a recommendation to the Committee. This item was subsequently withdrawn and combined with Item 237-2.

Regional Association Comments:

CWMA commented to stay consistent with the previous proposals for CNG and LNG; they are recommending this as a Developmental item. (See comments from Item 232-1.) CWMA forwarded this item to NCWM, recommending it as a Developing item.

WWMA heard concern from a regulatory official that the item would allow for multiple methods of sale in the marketplace which would be problematic. Another regulatory official agreed and added it would frustrate value comparison. The Committee awaits further information from the Natural Gas Steering Committee. WWMA forwarded this item to NCWM, recommending that it be an Informational item.

NEWMA forwarded this item to NCWM, recommending that it be an Informational item. See Item 232-1 for comments.

SWMA forwarded the item to NCWM, recommending it as a Developing item with the preferred method of sale for natural gas being by mass, allowing for supplemental labeling of conversion factors to convert mass to volume equivalents, and that the conversion factors be verified and clarified.

Additional letters, presentations, and data may have been part of the Committee's consideration. To review the supporting documentation, please refer to the *Report of the 98th National Conference on Weights and Measures* (SP 1171, 2013).

237-6 V Section 3.13. Oil, 3.13.1. Labeling of Vehicle Engine (Motor) Oil Required

(This item was Adopted.)

Source:

Automotive Oil Change Association (2013)

Purpose:

Prevent consumer confusion and government-sponsored product bias regarding legitimate, manufacturer recommended products, and to prevent installers and retailers from being held responsible for labeling requirements with respect to packaged goods.

Item Under Consideration:

Amend NIST Handbook 130, Engine Fuels and Automotive Lubricants Regulation as follows:

3.13. Oil.

3.13.1. Labeling of Vehicle Engine (Motor) Oil Required.

3.13.1.1. Viscosity. – The label on any vehicle engine (motor) oil container, receptacle, dispenser, or storage tank and the invoice or receipt from service on an engine that includes the installation of **bulk** vehicle motor oil dispensed from a receptacle, dispenser, or storage tank shall contain the viscosity grade classification preceded by the letters “SAE” in accordance with the SAE International’s latest version of SAE J300, “Engine Oil Viscosity Classification.”

(Amended 2012 **and 2014**)

~~**3.13.1.2. Intended Use.** – The label on any vehicle engine (motor) oil container shall contain a statement of its intended use in accordance with the latest version of SAE J183, “Engine Oil Performance and Engine Service Classification (Other than “Energy Conserving”).”~~

~~(Amended 2012)~~

~~**3.13.1.3.2. Brand.** – The label on any vehicle engine (motor) oil container and the invoice or receipt from service on an engine that includes the installation of **bulk** vehicle engine (motor) oil dispensed from a receptacle, dispenser, or storage tank shall contain the name, brand, trademark, or trade name of the vehicle engine (motor) oil.~~

~~(Added 2012)~~

~~**3.13.1.4.3. Engine Service Category.** – The label on any vehicle engine (motor) oil container, receptacle, dispenser or storage tank and the invoice or receipt from service on an engine that includes the installation of **bulk** vehicle engine (motor) oil dispensed from a receptacle, dispenser, or storage tank shall contain the engine service category, or categories, met in letters not less than 3.18 mm (¹/₈ in) in height, as defined by the latest version of SAE J183, “Engine Oil Performance and Engine Service Classification (Other than “Energy Conserving”),” ~~or~~ API Publication 1509, “Engine Oil Licensing and Certification System,” or European Automobile Manufacturers Association (ACEA) European Oil Sequences or Vehicle or Engine Manufacturer Standard as provided in Section 3.33.1.3.1.~~

~~(Amended 2012 **and 2014**)~~

3.33.1.3.1. Vehicle or Engine Manufacturer Standard. – **The label on any vehicle engine (motor) oil container, receptacle, dispenser, or storage tank and the invoice or receipt from service on an engine that includes the installation of vehicle engine (motor) oil dispensed from a receptacle, dispenser, or storage tank shall identify the specific vehicle or engine manufacturer standard, or standards, met in letters not less than 3.18 mm (1/8 in) in height. If the vehicle (motor) oil only meets a vehicle or engine manufacturer standard, the label must clearly identify that the oil is only intended for use where specifically recommended by the vehicle or engine manufacturer.**

(Added 2014)

3.13.1.4.12.3.2. Inactive or Obsolete Service Categories. – The label on any vehicle engine (motor) oil container, receptacle, dispenser, or storage tank and the invoice or receipt from service on an engine that includes the installation of vehicle engine (motor) engine oil dispensed from a receptacle, dispenser, or storage tank shall bear a plainly visible cautionary statement in compliance with the latest version of SAE J183, Engine Oil Performance and Engine Service Classification (Other than “Energy Conserving”)” Appendix A, whenever the vehicle engine (motor) oil in the container or in bulk does not meet an active API service category as defined by the latest version of SAE J183, “Engine Oil Performance and Engine Service Classification (Other than “Energy Conserving”).” **If a vehicle engine (motor) oil is identified as only meeting a vehicle or engine manufacturer standard, the labeling requirements in Section 3.13.1.3.1. Vehicle or Engine Manufacturer Standard apply.**

(Added 2012) (Amended 2014)

3.13.1.5.4. Tank Trucks or Rail Cars. – Tank trucks, rail cars, and types of delivery trucks that are used to deliver **bulk** vehicle engine (motor) oil are not required to display the SAE viscosity grade and service category or categories as long as the bill of lading other documentation provides that information.

(Added 2012) (Amended 2014)

3.13.1.65. Documentation. – When the engine (motor) oil is sold in bulk, an invoice, bill of lading, shipping paper, or other documentation must accompany each delivery. This document must identify the quantity of **bulk** engine (motor) oil delivered as defined in Sections 3.13.1.1. Viscosity; **3.13.1.2. Intended Use**; 3.13.1.32. Brand; 3.13.1.43. Engine Service Category; the name and address of the seller and buyer; and the date and time of the sale. For inactive or obsolete service categories, the documentation shall also bear a plainly visible cautionary statement as required in Section 3.13.1.43.12. Inactive or Obsolete Service Categories. Documentation must be retained at the retail establishment for a period of not less than one year.

(Added 2013) (Amended 2014)

(Amended 2012 and 2014)

Background/Discussion:

The vast majority of engine oil used at professional fast lube facilities is the most current category of American Petroleum Institute (API) licensed oil. However, older, specialty, and some non-American vehicles take engine oil not listed as active under API’s private regulatory scheme; some are former API licensed oils now considered “obsolete” or “inactive” and some are simply licensed by another organization like European Automobile Manufacturers Association (ACEA.) However, if the original equipment manufacturers (OEM) recommend those engine oils for their vehicles, consumers have a right to use them regardless of API’s blessing, and installers and retailers should be able to sell them without obstruction. (See Appendix C of the *Report of the 98th National Conference on Weights and Measures* [SP 1171, 2013].)

The Automotive Oil Change Association (AOCA) amendment is necessary because a cautionary statement appearing on service receipts without explanation will inappropriately mislead consumers with older and uncommon model vehicles into believing they should not use OEM-recommended engine oil. The average fast lube customer does not recognize API or SAE (Society of Automotive Engineers) to mean anything in particular but “CAUTION” and “OBSOLETE” in big capital letters could only be understood as negative. Scaring consumers in this way will

not only push them to buy more expensive engine oil they do not need, but also engender distrust in their installer service providers for recommending and/or using OEM recommended engine oil.

The average age of cars in the current fleet is nearly 11-years old and it is not unusual for fast lubes to have customers with vehicles twice that age; for example, there are millions of opportunities for consumers to be misled into rejecting proper engine oil. The fact is American consumers are hanging onto their vehicles longer than API is hanging onto its service categories. When API designates a motor oil category as inactive, this does not mean consumers with vehicles designed to use that category turn in their cars or otherwise want to buy a more expensive grade of motor oil going forward. Therefore, a category of motor oil designed to work for particular makes and models of vehicles should not be burdened with the chilling effect of a cautionary statement absent a specific clarification acknowledging the preeminence of the OEM's recommendations.

The new standard phase-in factor must be considered as well. When API publishes a new edition of 1509, *Engine Oil Licensing and Certification Systems*, and/or creates a new service category, a reasonable phase-in period for bulk oil stock is necessary to accommodate older vehicle owners' needs; for example, it may be in those customers' best interests, both functionally and economically, to use motor oil developed in accordance with an earlier edition or service category so long as the automobile manufacturer originally recommended it and its continued use has no impact on any remaining warranty coverage. Although it is common for API to retain a couple of the most recent service categories as "active," API could choose to make all but the most recent service category "obsolete." For fast lube operators to automatically upgrade bulk oil stock at API-determined intervals would be tantamount to giving API control over the price of oil change services regardless of what the market can bear.

This amendment also addresses packaged engine oil products already on the shelf or in the distribution chain when API makes a unilateral decision to deactivate an engine oil category. As a practical matter, tens of thousands of retailers and installers cannot re-mark millions of packages to coincide with API's timing or take the financial hit for sending it all back in violation of purchase agreements. This amendment resolves this problem so that the requirement for proper labeling, of packaged containers, of engine oil rest with the party in control of the packaging-the manufacturers.

Without the amendment, the labeling requirement will be very difficult to enforce given the inventory of packaged goods remaining after an active engine oil category has been declared inactive or obsolete.

It was noted that fast lubes would experience catastrophic business loss if customers with older and uncommon model vehicles were alienated. Maintenance costs for consumers with older model cars could easily double if they are confused into believing they need the latest category of engine oil.

AOCA contends that the proposed amendment will accomplish three important goals: 1) prevent unintended consumer confusion and product stigma from using a cautionary statement by reestablishing the connection to OEM recommendations; 2) provide the necessary exemption to protect retailers and installers for selling lawful packaged inventory; and 3) which leads to an increase in practical enforcement prospects.

The most analogous regulatory situation to the one at issue in AOCA's proposed amendment is found in the Federal Trade Commission's (FTC) Test Procedures and Labeling Standards for Recycled Oil (16 CFR 31, www.gpo.gov/fdsys/pkg/CFR-2011-title16-vol1/pdf/CFR-2011-title16-vol1-part312.pdf). In the rulemaking process, FTC specifically rejected requiring recycled engine oil to be labeled "recycled" because of the stigma associated with the term at that time (see 72 FR 14410 – 14413 & FN11 (1 H.R. Rep. No. 96-1415, 96th Cong. 2d Sess. 6 (1980), reproduced at 1980 U.S. Code Cong. & Ad. News 4354, 4356. "Oil should be labeled on the basis of performance characteristics and fitness for its intended use, and not on the basis of the origin of the oil.")). The National Automobile Dealers Association also commented in favor of this approach: "NADA further stated that by not requiring that "substantially equivalent" recycled oils be labeled "recycled" or "re-refined," used oil processors are able to market their products effectively." (72 FR at 14411) No "recycled" or other potentially derogatory designation is required so long as the finished product meets the appropriate API standard.

NCWM 2013 Interim Meeting: A state opposed this item and would like to see it Withdrawn. The FALS Chairman remarked that there are several engine oils designed for specific model vehicles and the FALS is working to resolve

this issue. A Committee member remarked that a statement of accountability should be included in the language. The Committee would like to see additional language developed by FALS and made this an Informational item.

NCWM 2013 Annual Meeting: The FALS submitted modified language for Sections 3.13.1.4. Engine Service Category, 3.13.1.4.1. Vehicle or Engine Manufacturer Standard and 3.33.1.4.1.2. Inactive or Obsolete Service Categories. The Committee would like to have regional input on this modified language to review at the 2014 NCWM Interim Meeting.

NCWM 2014 Interim Meeting: The FALS and API provided the Committee with modified language. This modified language removes Section 3.13.1.2. Intended Use. Section 3.13.1.1. was modified to allow for abbreviations on tickets. One member questioned the labeling for underground storage containers and their legibility.

2014 NCWM Annual Meeting: The Committee heard support for this item and agreed to modify the language in its Interim Report to that shown in this Final Report in the Item Under Consideration.

Regional Association Comments:

CWMA: Refer to comments in Item 232-3. CWMA recommended that this item be a Developing item. At the 2014 CWMA Annual Meeting, it was noted that this item has companion Items 232-4 and 237-11. An industry representative commented that he supported all items with an additional change to Item 237-11 (see Item 237-11). The Committee believes the item has been fully developed and is ready for Voting.

The WWMA heard from an American Petroleum Institute (API) representative that they supported the proposed changes to NIST Handbook 130 which are necessary for the following reasons: 1) adding the reference to ACEA will expand the current regulation to cover engine oil performance specifications recommended by many European vehicle and engine manufacturers; and 2) allowing engine oil labels, invoices and receipts to list a performance specification set by a particular vehicle or engine manufacturer will address unique situations where an oil cannot claim any performance level maintained by API or ACEA. The FALS Chairman reported that it is currently considering these changes, but have not reached consensus, and they are seeking a resolution by 2014 NCWM Interim. The Committee supports ongoing work by FALS, pending agreement with stakeholders. WWMA recommended that this item be an Informational item.

NEWMA received comment in 2012 from API it opposes the item and that specifics have been submitted in writing. API suggested this proposal and Item 237-4 be Withdrawn. General Motors indicated the proposal appears to allow older formulations of engine oil, but newer formulations give better performance, even in older vehicles. GM prefers current formulation of engine oil. NEWMA did not forward the item to NCWM. At the 2013 NEWMA Annual Meeting, Mr. Kevin Ferrick (API) indicated they submitted comments to their opposition of this item and requested this item be Withdrawn. NEWMA would like to see additional information from the FALS. In 2013, Mr. Ferrick commented to NEWMA that final language review should be made through FALS. No other comments were heard and NEWMA recommended this be an Information item. At the 2014 NEWMA Annual Meeting, with no other comments, the clarified language was recommended to be forwarded as a Voting item.

SWMA reported in 2012 that an API representative voiced opposition to the item and provided written testimony in dispute of the comments and claims made by the submitter: The SWMA Committee believed there was lack of support for the item and that the oil change industry has a poor understanding of the API standards. SWMA did not forward the item to NCWM. At the 2013 SWMA Annual Meeting, the association supported the carryover item being a Developing item on the NCWM agenda to allow FALS an opportunity to work on Section 3.33.1.4. in the proposal (which should be Section 3.13.1.4.) and to give consideration to adding the ACEA standards to the proposal.

Additional letters, presentations, and data may have been part of the Committee's consideration. To review the supporting documentation, please refer to the *Report of the 98th National Conference on Weights and Measures* (SP 1171, 2013).

237-7 V Section 3.2.7. Documentation for Dispenser Labeling Purposes

(This item was Adopted.)

Source:

Archer Daniels Midland Company (2014)

Purpose:

Update the information for documentation for dispenser labeling purposes in the method of sale section of the Uniform Engine Fuels and Automotive Lubricants regulations of NIST Handbook 130. This update will recognize the EPA regulations for product transfer documents for gasoline and gasoline/oxygenate blends.

Item under Consideration:

Amend NIST Handbook 130, Uniform Engine Fuels and Automotive Lubricants Regulation as follows:

3.2.7. Documentation for Dispenser Labeling Purposes. – The retailer shall be provided, at the time of delivery of the fuel, on product transfer documents such as an invoice, bill of lading, shipping paper, or other documentation; ~~a declaration of the predominant oxygenate or combination of oxygenates present in concentrations sufficient to yield an oxygen content of at least 1.5 mass percent in the fuel. Where mixtures of only ethers are present, the fuel supplier may identify either the predominant oxygenate in the fuel (i.e., the oxygenate contributing the largest mass percent oxygen) or alternatively, use the phrase “contains MTBE or other ethers.”~~ In addition, any gasoline containing more than 0.15 mass percent oxygen from methanol shall be identified as “with” or “containing” methanol. This documentation is only for dispenser labeling purposes; it is the responsibility of any potential blender to determine the total oxygen content of the engine fuel before blending.

(Amended 1996 and 2014)

(a) Information that complies with 40 CFR § 80.1503 when the fuel contains ethanol.

(b) For fuels that do not contain ethanol, information that complies with 40 CFR § 80.1503 and a declaration of the predominant oxygenate or combination of oxygenates present in concentrations sufficient to yield an oxygen content of at least 1.5 mass percent in the fuel. Where mixtures of only ethers are present, the fuel supplier may identify either the predominant oxygenate in the fuel (i.e., the oxygenate contributing the largest mass percent oxygen) or alternatively, use the phrase “contains MTBE or other ethers.”

(c) Gasoline containing more than 0.15 mass percent oxygen from methanol shall be identified as “with” or “containing” methanol.

(Added 2014)

Background/Discussion:

The proposal incorporates existing EPA regulations. NCWM 2014 Interim: Mr. Meeting Chuck Corr, submitter of this item, informed the Committee this new language now aligns with current EPA regulations. The Committee moved this item forward as a Voting item.

NCWM 2014 Annual Meeting: The Committee was informed by Mr. Matthew Curran, FALS Chair that if this item was adopted there needs to be a method of sale added with like language. Mr. Corr concurred with this modification for the method of sale and spoke in support of this item. The Committee agreed to modify the language in its Interim Report to that shown in this Final Report in the Item Under Consideration and added Item 232-8, under the Method of Sale.

Regional Association Comments:

NEWMA 2014 Annual Meeting: The Committee recommended this as a Voting item in order to harmonize with EPA regulations.

CWMA's L&R Committee supports this item as it provides recognition of federal requirements for product transfer documents. CWMA forwarded it to NCWM, recommending it as a Voting item. CWMA 2014 Annual Meeting: The submitter of this item stated that there should have been a companion item under Method of Sale of Commodities. The CWMA L&R Committee agrees that the item should include in the Method of Sale under Section 2.20.2. and is ready for Voting status.

Additional letters, presentations, and data may have been part of the Committee's consideration. To review the supporting documentation, please refer to the *Report of the 98th National Conference on Weights and Measures* (SP 1171, 2013).

237-8 V Section 4.3. Dispenser Filters

(This item returned to Committee.)

Source:

Missouri Department of Agriculture (2012)

Purpose:

Recognize the need for 10-micron or smaller nominal pore-sized filters for today's diesel engines.

Item Under Consideration:

4.3. Dispenser Filters.

4.3.1. Engine Fuel Dispensers.

- (a) All gasoline, gasoline-alcohol blends, gasoline-ether blends, E85 fuel ethanol and M85 methanol dispensers shall have a 10 micron or smaller nominal pore-sized filter.
- (b) All biodiesel, biodiesel blends, diesel, and kerosene dispensers shall have a ~~30~~ **10** micron or smaller nominal pore-sized filter **except for dispensers with flow rates greater than 15 gallons per minute which shall have a 30 micron or smaller nominal pore size filter.**

Background/Discussion:

Abnormal dispenser filter plugging at retail will alert the retailer of potential storage tank problems. Requiring 10-micron filters for all products will reduce the inventory and the potential of installing the wrong filter for all products at the same site.

NCWM 2012 Interim Meeting: Mr. Hayes, FALS Chair, informed the Committee that FALS recommended that this item be Informational because of industry concerns that 10-micron filters would be too restrictive of flow in high-flow systems. One industry representative expressed opposition for the use of 10-micron filters and recommends this item to be Withdrawn. A representative of an automobile manufacturer claimed diesel passenger vehicles do not have the sophisticated filtration systems commonly found on commercial duty vehicles and 10-micron filters on dispensers are needed for protection from particulate contamination. As proposed, this item could cause clogging of diesel dispenser filters in colder climates. The Committee believes this item has merit but lacks a consensus and also believes that FALS needs to address these concerns. The 2012 L&R Committee designated this item as an Informational item and assigned it to FALS for further development.

NCWM 2012 Interim Meeting: It was apparent to the Committee that that there are many unresolved issues related to passenger vehicles. The Committee encourages the FALS to continue developing this item.

NCWM 2012 Annual Meeting: Several stakeholders spoke in opposition on this item. Mr. Hayes, FALS Chair remarked that the FALS worked on this item in 2007 and believes FALS needs to continue to work on this item. The NCWM L&R Committee agreed that this item is not ready and supports the continued development by FALS.

NCWM 2013 Interim Meeting: Mr. Hayes (Missouri), FALS Chairperson, remarked that a similar item was bought before the Committee in 2007. FALS did not have enough time in their work session to work on this item. There are several stakeholders and states that are having issues with the terminology and would like it removed from the agenda. Mr. Hayes remarked that they supported this item because contamination is an issue with cars that do not have filtering systems. The Committee reviewed comments from the Regional Associations however; FALS did not have sufficient time review and consider recommendation to the Committee. The Committee would like for FALS to continue to work on this item and is proposing this as an Informational item.

NCWM 2013 Annual Meeting: Mr. Hayes, FALS Chair requested that the Committee allow them to continue to work on a recommendation for this item. There was opposition on moving this item forward. In less than two years since this proposal came forward, there has been no data developed. The Committee reviewed the Regional Association reports, open hearing comments, and letters received and changed the status of this item to Developing.

NCWM 2014 Interim Meeting: Mr. Hayes who submitted the proposal offered modified language and supporting data to support the flow rate on 10-micron diesel filters. There was considerable discussion in regards to the fill time reduction, burdensome cost for station owners, and equipment and filter maintenance. It was noted that there is work being done within ASTM but, at this time, that information cannot be shared. The Committee reviewed the Item under Consideration within NCWM Interim Publication 15 (2014). The Committee moved forward the modified language provided by Mr. Hayes for consideration as a Voting item.

NCWM 2014 Annual Meeting: The Committee reviewed several letters and additional data submitted by the Petroleum Marketers Association of American (PMAA). The FALS recommended this item move forward for a Vote. During the Open Hearings, there were mixed concerns in regard to this this item. Numerous concerns were expressed concerning the data from PMAA. Several comments were heard that ASTM should be allowed to develop a standard.

Regional Association Comments:

CWMA's L&R Committee heard no opposing comments and believes the proposal protects consumer vehicles and alerts retailers of potential product quality problems. Comments from previous meetings included a remark from an official indicating a smaller porosity filter may be acceptable, but for now this is a reasonable start. General Motors (GM) supported this item for passenger vehicles, as these vehicles now have 4-micron filters. Several industry representatives did not support this item during a past meeting because they believe this is a dispenser protection issue rather than a consumer protection issue. A state regulator remarked that it is a fuel quality issue, which impacts consumers' vehicles and fuel systems. Officials clarified that the proposal should only apply to passenger type vehicles, and it would specifically exempt high-flow rate meters such as truck stop meters. CWMA supported the following proposal and recommended it as a Voting item.

4.3. Dispenser Filters.

4.3.1. Engine Fuel Dispensers.

- (a) All gasoline, gasoline-alcohol blends, gasoline-ether blends, E85 fuel ethanol and M85 methanol dispensers shall have a 10 micron or smaller nominal pore-sized filter.
- (b) All biodiesel, biodiesel blends, diesel, and kerosene dispensers shall have a ~~30~~ 10 micron or smaller nominal pore-sized filter **except for dispensers with flow rates greater than 15 gallons per minute which shall have a 30 micron or smaller nominal pore size filter.**

CWMA 2014 Annual Meeting: A regulator commented this item has been vetted through the regions several times. There is additional data on the NCWM website that was shared with FALS. It was stressed that this item is for retail motor fuel dispensers for passenger vehicles not high-flow meters. The regulator also mentioned the work done by his staff during cold weather to test whether or not flow rates through 10-micron filters were more diminished than fuel flowing through 30-micron filters during sub-zero weather. The regulator stated FALS supports this item. A second regulator commented that he was seeking clarification on whether determination of the flow rate would be made with a marked flow rate or flow rate at the dispenser. Other regulators stated the intent was to have 10 micron

filters on passenger vehicle dispensers and light trucks only. This proposal best accomplishes that end. An industry representative asked about the cost between the 10-micron filters and 30-micron filters. A regulator responded costs were the same. The CWMA L&R Committee believes the item has been fully developed and is ready for Voting.

WWMA heard from one regulatory official recommending Withdrawal of the item because it is unnecessary. There is concern with the potential negative impact on the speed of fuel delivery. The submitting regulatory official supports the item with the language for Section 4.3.1.(b) as presented above in the CWMA Interim Report. WWMA recommends this item as a Voting item.

NEWMA reported in 2011 that questions were raised as to whether or not “measurement” of filter content was within the ability of weights and measures officials. It was noted that better filters may enhance fuel quality. The Committee believes the proposal has potential given input from industry and stakeholders. NEWMA forwarded the item to NCWM recommending it as a Developing item.

NEWMA 2012 Interim Meeting: The Committee reviewed the CWMA report. NEWMA recommended it to be an Informational item and requested it be reviewed by FALS.

NEWMA 2013 Interim and Annual Meetings: At both meetings, it was recommended that that the item be Withdrawn. Attendees commented that this item is not a weights and measures issue, but a manufacturer’s issue.

NEWMA 2014 Annual Meeting: The Committee recommended this item be forwarded as a Voting item.

Attendees commented that this item is not a weights and measures issue, but rather a manufacturer’s issue. At the 2014 NEWMA Annual Meeting, they recommend this be a Voting item.

SWMA reported in 2011 that an industry representative stated that standard retailer dispensers use a 10-micron filter, and high capacity dispensers use 30-micron filters (i.e., diesel dispensed at truck stops). The company’s engineers have determined that reducing a 30-micron filter to a 10-micron filter will drastically reduce flow rate to trucks. Another industry representative agreed and re-iterated that truck stops would see a tremendous reduction in flow. The Committee believed this proposal was not practical and would have a negative impact and undue burden on the trucking industry. SWMA did not forward the item to NCWM.

SWMA 2012 Annual Meeting: An industry representative commented that the current technology to put a 10-micron filter on diesel at a truck stop will prohibit fuel from being dispensed in a timely manner and, therefore, opposes this. The Committee recommends the use of 10-micron filters be limited to passenger vehicle meters and specifically exempt high-flow rate meters. SWMA recommended the item be a Voting item but with the changes as described by the Committee.

SWMA 2013 Annual Meeting: The SWMA supported moving this item forward as a Voting item on the NCWM agenda modifying the requirements to read; 10 micron filters on devices delivering 15 gpm or less and 30-micron filters for greater than 15 gpm.

Additional letters, presentations, and data may have been part of the Committee’s consideration. To review the supporting documentation, please refer to the *Report of the 98th National Conference on Weights and Measures* (SP 1171, 2013).

237-9 V Section 1. Definitions, Section 2. Standard Fuel Specifications, and Section 3. Classification and Method of Sale of Petroleum Items

(This item was Adopted.)

Source:

Fuels and Lubricants Subcommittee Task Group (2012)

Purpose:

Update regulations related to flex fuels.

Item Under Consideration:

Amend the Uniform Engine Fuels and Automotive Lubricants Regulation as follows:

Section 1. Definitions

1.13. Denatured Fuel Ethanol. – ~~“Ethanol” as defined in Section 1.20. Ethanol. An ethanol blend component for use in gasoline-ethanol blends and ethanol flex fuel. The ethanol is rendered unfit for beverage use by the addition of denaturants under formulas approved by the Alcohol and Tobacco Tax and Trade Bureau (TTB), www.ttb.gov. ASTM D4806, “Standard Specification for Denatured Fuel Ethanol for Blending with Gasolines for Use as Automotive Spark-Ignition Engine Fuel” describes the acceptable denaturants for denatured fuel ethanol to be blended into spark ignition engine fuels.~~

(Amended 2014)

1.21. ~~E85 Fuel-Ethanol Flex Fuel.~~ – ~~A blend Blends~~ of ethanol and hydrocarbons restricted for use as fuel in ground vehicles equipped with flexible-fuel spark-ignition engines. ~~of which the ethanol portion is (nominally 75 to 85 volume percent denatured fuel ethanol).~~

(Amended 2014)

1.20. Ethanol. – Also known as ~~“Denatured Fuel Ethanol,” means nominally anhydrous ethyl alcohol meeting ASTM D4806 standards. It is intended to be blended with gasoline for use as a fuel in a spark-ignition internal combustion engine. The denatured fuel ethanol is first made unfit for drinking by the addition of the Alcohol and Tobacco Tax and Trade Bureau (TTB), www.ttb.gov, approved substances before blending with gasoline.~~ “ethyl alcohol.” Ethanol is provided in gasoline-ethanol blends by blending denatured fuel ethanol. See Section 1.13. Denatured Fuel Ethanol.

(Amended 20XX)

1.53. Wholesale Purchaser Consumer. – Any person who is an ultimate ~~gasoline~~ consumer of gasoline, fuel methanol, ethanol flex fuel, ~~fuel-ethanol~~, diesel fuel, biodiesel, biodiesel blends, fuel oil, kerosene, aviation turbine fuels, natural gas, compressed natural gas, or liquefied petroleum gas and who purchases or obtains the product from a supplier and receives delivery of that product into a storage tank.

(Added 1998) (Amended 1999 and 2014)

Section 2. Standard Fuel Specifications

2.7. Denatured Fuel Ethanol. – Intended for blending with gasoline shall meet the latest version of ASTM D4806, “Standard Specification for Denatured Fuel Ethanol for Blending with Gasolines for Use as Automotive Spark-Ignition Engine Fuel.”

2.10. ~~E85 Fuel-Ethanol Flex Fuel.~~ – ~~shall meet the latest version of the following ASTM D5798, “Standard Specification for Ethanol Fuel Blends for Flexible Fuel Ethanol (Ed75 Ed85) for Automotive Spark Ignition Engines.”~~ Ethanol flex fuel is covered by one of two ASTM standards based on the ethanol concentration of the blend:

(a) Ethanol flex fuel containing 51 to 83 volume percent ethanol shall meet the latest version of ASTM D5798, “Standard Specification for Ethanol Fuel Blends for Flexible Fuel Automotive Spark-Ignition Engines”; and

(b) Ethanol flex fuel containing 16 to 50 volume percent ethanol shall be blended, stored and conveyed for consumption in accordance with the latest version of ASTM D7794, “Standard Practice for Blending Mid-Level Ethanol Fuel Blends for Flexible Fuel Vehicles with Automotive Spark-Ignition Engines.”

(Added 1997) **(Amended 2014)**

Section 3. Classification and Method of Sale of Petroleum Products

3.8. ~~E85 Fuel~~ **Ethanol Flex Fuel.**

3.8.1. How to Identify ~~E85 Fuel~~ **Ethanol Flex Fuel.** ~~Fuel~~ **Ethanol flex fuel** shall be identified as **Ethanol Flex Fuel or EXX Flex Fuel** ~~E85~~.

3.8.2. Labeling Requirements.

(a) **Ethanol flex fuel with an ethanol concentration no less than 51 and no greater than 83 volume percent shall be labeled “Ethanol Flex Fuel, minimum 51 % ethanol.”. Fuel ethanol shall be labeled with its automotive fuel rating in accordance with 16 CFR Part 306.**

(b) Ethanol flex fuel with an ethanol concentration less than or equal to 50 volume percent shall be labeled “EXX Flex Fuel, minimum YY % ethanol”, where the XX is the ethanol concentration in volume percent and YY is XX minus 5. The actual ethanol concentration of the blend shall be XX volume percent plus or minus 5 volume percent.

~~(c)~~**(b)** A label shall be posted which states “For Use in Flexible Fuel Vehicles (FFV) Only.” This information shall be clearly and conspicuously posed on the upper 50 % of the dispenser front panel in a type at least 12.7 mm (½ in) in height, 1.5 mm (1/16 in) stroke (width of type). A label shall be posted which states, ~~“Consult Vehicle Manufacturer Fuel Recommendations,”~~ **“CHECK OWNER’S MANUAL,”** and shall not be less than 6 mm (¼ in) in height by 0.8 mm (1/32 in) stroke; block style letters and the color shall be in definite contrast to the background color to which it is applied.

(Amended 2007, 2008, **and 2014)**

Section 4. Retail Storage Tanks and Dispenser Filters

4.1. **Water in Gasoline-Alcohol Blends, Biodiesel Blends, ~~E85 Fuel~~ Ethanol Flex Fuel, Aviation Gasoline, and Aviation Turbine Fuel.** – No water phase greater than 6 mm (¼ in) as determined by an appropriate detection paste or other acceptable means, is allowed to accumulate in any tank utilized in the storage of gasoline-alcohol blend, biodiesel, biodiesel blends, ~~E85 Fuel~~ **ethanol flex fuel blends**, aviation gasoline, and aviation turbine fuel.

(Amended 2014)

4.2. **Water in Gasoline, Diesel, Gasoline-Ether, and Other Fuels.** – Water shall not exceed 25 mm (1 in) in depth when measured with water indicating paste or other acceptable means in any tank utilized in the storage of diesel, gasoline, gasoline-ether blends, and kerosene sold at retail except as required in Section 4.1. Water in Gasoline-Alcohol Blends, Aviation Blends, Biodiesel Blends, ~~E85 Fuel~~ **Ethanol Flex Fuel**, Aviation Gasoline, and Aviation Turbine Fuel.

(Amended 2008, ~~and 2012~~, **and 2014)**

4.3. Dispenser Filters.

4.3.1. Engine Fuel Dispensers.

- (a) All gasoline, gasoline-alcohol blends, gasoline-ether blends, ~~E85 fuel~~ ethanol flex fuel and M85 methanol dispensers shall have a 10 micron or smaller nominal pore-sized filter.
- (b) All biodiesel, biodiesel blends, diesel, and kerosene dispensers shall have a 30 micron or smaller nominal pore-sized filter.

(Added 2008) (Amended 2014)

Background/Discussion:

The current wording in NIST Handbook 130 related to fuels restricted to use in flex fuel vehicles should be reviewed. Input gathered from the regional meetings and other stakeholders will be utilized by FALS to develop recommended modifications to NIST Handbook 130.

NCWM 2012 Interim Meeting: The Committee received an update from Mr. Corr, (Chair of the Task Group [TG] under the FALS), will lead an effort to get regional input on a transition and implementation date. The 2012 L&R Committee designated this item as an Informational item.

NCWM 2012 Annual Meeting: Mr. Corr, Chair of the TG under the FALS, reported on behalf of FALS TG that approximately 18 areas of NIST Handbook 130 have been identified where modifications may be needed. A stakeholder voiced full support of the TG efforts. Mr. Corr's group will report again at the 2013 NCWM Interim Meeting.

NCWM 2013 Interim Meeting: Mr. Corr provided an update of the language changes recommended for addressing the full range of fuels restricted to flex fuel vehicles in NIST Handbook 130. He remarked that no feedback has been provided to him from stakeholders and states concerning the language changes. Mr. Corr also stated FALS has also not reviewed and discussed the proposed changes. The Committee recommended this as an Informational item so interested parties can provide comments.

NCWM 2013 Annual Meeting: Mr. Corr provided initial language changes for the Uniform Regulation for the Method of Sale, Section 2.30. ~~E85-Fuel~~ Ethanol Flex Fuel Blends, and this language was placed under the Method of Sale of Commodities section and appears as Item 232-6.

NCWM 2014 Interim Meeting: Mr. Corr submitted modified language that aligns also with Item 232-6 within the report. The Committee recommends this as a Voting item.

NCWM 2014 Annual Meeting: The Committee heard from Mr. Matthew Curran, FALS Chair, who is in contact with the Federal Trade Commission (FTC) in regards to the FTC proposed ruling on this issue. Currently FTC is awaiting the outcome of the 2014 NCWM Annual Meeting results before proceeding (refer to Appendix C) with their proposal. The Committee agreed to modify the language in its Interim Report to that shown in this Final Report in the Item Under Consideration.

Regional Association Comments:

CWMA reported FALS recommended the alternate proposal below be a Voting item. The Committee agreed. During past regional meetings, Mr. Corr gave a presentation on "Flex Fuel Task Force Update." This presentation noted that ASTM D7794-12 and D5798-11 cover the standard for a full range of ethanol concentrations. Several commented that the 51 % to 83 % range is too broad. A regulatory official was concerned with blends at the pumps they can choose a blend and percentage. A stakeholder remarked that consumers are concerned with price and miles per gallon (MPG) and may not have enough knowledge in regards to blends. Another stakeholder remarked that ASTM 5798 is at the terminal and the Conference needs to address this issue.

Section 1. Definitions

1.13. Denatured Fuel Ethanol. – ~~“Ethanol” as defined in Section 1.20. Ethanol. An ethanol blend component for use in gasoline-ethanol blends and Ethanol Flex Fuel blends. The ethanol is rendered unfit for beverage use by the addition of denaturants under formulas approved by the Alcohol and Tobacco Tax and Trade Bureau (TTB), www.ttb.gov. ASTM D4806, “Standard Specification for Denatured Fuel Ethanol for blending with Gasolines for Use as Automotive Spark-Ignition Engine Fuel” which describes the acceptable denaturants for denatured fuel ethanol to be blended into spark-ignition engine fuels.~~

1.17. Ethanol Flex Fuel Blends ~~E85 Fuel Ethanol.~~ – ~~A blend Blends~~ of ethanol and hydrocarbons restricted for use as fuel in ground vehicles equipped with flexible-fuel spark-ignition engines. ~~of which the ethanol portion is (nominally 75 to 85 volume percent denatured fuel ethanol).~~

1.20. Ethanol. – Also known as “ethyl alcohol”. Ethanol is provided in gasoline-ethanol blends and Ethanol Flex Fuel blends by blending denatured fuel ethanol. See “Denatured Fuel Ethanol” in Section 1.13. “Denatured Fuel Ethanol,” means nominally anhydrous ethyl alcohol meeting ASTM D4806 standards. It is intended to be blended with gasoline for use as a fuel in a spark ignition internal combustion engine. The denatured fuel ethanol is first made unfit for drinking by the addition of the Alcohol and Tobacco Tax and Trade Bureau (TTB), www.ttb.gov, approved substances before blending with gasoline.

1.53. Wholesale Purchaser Consumer. – Any person who is an ultimate ~~gasoline~~ consumer of gasoline, fuel methanol, Ethanol Flex Fuel blends, fuel ethanol, diesel fuel, biodiesel, biodiesel blends, fuel oil, kerosene, aviation turbine fuels, natural gas, compressed natural gas, or liquefied petroleum gas and who purchases or obtains the product from a supplier and receives delivery of that product into a storage tank.

Section 2. Standard Fuel Specifications

2.7. Denatured Fuel Ethanol. – Intended for blending with gasoline shall meet the most recent version of ASTM D4806, “Standard Specification for Denatured Fuel Ethanol for Blending with Gasolines for Use as Automotive Spark-Ignition Engine Fuel.”

2.10. Ethanol Flex Fuel ~~E85 Fuel Ethanol.~~ – ~~Shall meet the most recent version of the following ASTM D5798, “Standard Specification for Fuel Ethanol (Ed75 Ed85) for Automotive Spark Ignition Engines.” Ethanol Flex Fuel blends are is covered by one of two ASTM standards based on the ethanol concentration of the blend:~~

- (a) Ethanol Flex Fuel blends containing 51 to 83 volume percent ethanol shall meet the latest version of ASTM D5798, “Standard Specification for Ethanol Fuel Blends for Flexible-Fuel Automotive Spark-Ignition Engines”; and
- (b) Ethanol Flex Fuel Blends containing 16 to 50 volume percent ethanol shall be blended, stored and conveyed for consumption in accordance with the latest version of ASTM D7794, “Standard Practice for Blending Mid-Level Ethanol Fuel Blends for Flexible-Fuel Vehicles with Automotive Spark-Ignition Engines.”

Section 3. Classification and Method of Sale of Petroleum Products

3.8. Ethanol Flex Fuel Blends ~~E85 Fuel Ethanol.~~

3.8.1. How to Identify ~~Ethanol Flex Fuel Blends E85 Fuel Ethanol.~~ – Ethanol Flex Fuel blends Fuel ethanol shall be identified as Ethanol Flex Fuel or EXX Flex Fuel ~~E85.~~

3.8.2. Labeling Requirements.

(a) Ethanol Flex Fuel blends with an ethanol concentration no less than 51 and no greater than 83 volume percent shall be labeled “Ethanol Flex Fuel, minimum 51 % ethanol”. Fuel ethanol shall be labeled with its automotive fuel rating in accordance with 16 CFR Part 306.

(b) Ethanol Flex Fuel blends with an ethanol concentration less than or equal to 50 volume percent shall be labeled “EXX Flex Fuel, minimum YY % ethanol”, where the XX is the target ethanol concentration in volume percent and YY is XX minus 5. The actual ethanol concentration of the blend shall be XX volume percent plus or minus 5 volume percent.

(c)(b) A label shall be posted which states “For Use in Flexible Fuel Vehicles (FFV) Only.” This information shall be clearly and conspicuously posed on the upper 50 % of the dispenser front panel in a type at least 12.7 mm (½ in) in height, 1.5 mm (1/16 in) stroke (width of type). A label shall be posted which states, **“CHECK OWNER’S MANUAL”, “Consult Vehicle Manufacturer Fuel Recommendations,”** and shall not be less than 6 mm (¼ in) in height by **0.8 mm (1/32 in) stroke; block style letters** and the color shall be in definite contrast to the background color to which it is applied.

(Amended 2007, ~~and~~ 2008, and 20XX)

Section 4. Retail Storage Tanks and Dispenser Filters

4.1. Water in Gasoline-Alcohol Blends, Biodiesel Blends, Ethanol Flex Fuel Blends, ~~E85 Fuel Ethanol~~, Aviation Gasoline, and Aviation Turbine Fuel. – No water phase greater than 6 mm (¼ in) as determined by an appropriate detection paste or other acceptable means, is allowed to accumulate in any tank utilized in the storage of gasoline-alcohol blend, biodiesel, biodiesel blends, Ethanol Flex Fuel blends ~~E85 fuel ethanol~~, aviation gasoline, and aviation turbine fuel.

4.2. Water in Gasoline, Diesel, Gasoline-Ether, and Other Fuels. – Water shall not exceed 25 mm (1 in) in depth when measured with water indicating paste or other acceptable means in any tank utilized in the storage of diesel, gasoline, gasoline-ether blends, and kerosene sold at retail except as required in Section 4.1. Water in Gasoline-Alcohol Blends, Aviation Blends, Biodiesel Blends, Ethanol Flex Fuel Blends ~~E85 Fuel Ethanol~~, Aviation Gasoline, and Aviation Turbine Fuel.

4.3. Dispenser Filters.

4.3.1. Engine Fuel Dispensers.

(a) All gasoline, gasoline-alcohol blends, gasoline-ether blends, Ethanol Flex Fuel blends ~~E85 fuel ethanol~~, and M85 methanol dispensers shall have a 10 micron or smaller nominal pore-sized filter.

(b) All biodiesel, biodiesel blends, diesel, and kerosene dispensers shall have a 30 micron or smaller nominal pore-sized filter.

CWMA 2014 Annual Meeting: An industry representative encouraged support of this item; FALS also recommends its adoption. A regulator summarized a recent Notice of Proposed Rule from the FTC. He indicated the proposal falls short in a number of areas: 1) for E15, the only requirement would be an EPA label – the FTC proposal does not require an octane rating; 2) ethanol blends above 15 % to 83 % will be posted in units of 10 percent increments; and 3) the term “E85” can no longer be used. A second industry representative commented that the FTC proposal is a regression and creates problems; he urged support for this item. FALS is considering submitting comments to FTC regarding the proposed rule. The CWMA L&R Committee agrees with the comments from regulators and industry, believes the item has been fully developed, and is ready for Voting.

WWMA heard from industry representative stating that FALS recommends the item be moved to Voting Status with the same changes identified in the above CWMA comments. WWMA recommended that this item as modified be a Voting item.

NEWMA recommended in 2012 that the item remain as an Informational item. During its 2013 Annual Meeting, NEWMA supported the ongoing work being done by the Task Group and recommended it as an Informational item. At the 2013 NEWMA Interim Meeting, an industry representative stated that FALS recommends the item be moved to Voting status with the same changes as shown above in the CWMA comments. At the 2014 NEWMA Annual Meeting, the Committee recommended this be a Voting item to make it consistent with the ASTM on volatility and flex fuel language.

SWMA heard a presentation in 2011 from Mr. Corr. He identified several areas where stakeholder input is needed to propose updates to NIST Handbook 130 and to reflect new language in ASTM D5798. No comments were made during the hearing. FALS is expected to have a recommendation for the 2012 NCWM Interim Meeting. SWMA forwarded the item to NCWM, recommending it as a Developing item.

SWMA 2012 Annual Meeting: Mr. Corr commented as Chair of the FALS TG that the group is working on language to reflect the new ASTM D7794 and modified D5798 standards for fuels restricted to flex fuel vehicles. It should be available for review at the NCWM Interim Meeting. Mr. Russ Lewis (Marathon Petroleum) gave a presentation in support of the proposal, taking into account the recently modified ASTM D5798 “Specifications for Ethanol Fuel Blends for Flexible Fuel Automotive Spark Ignition Engines.” Mr. Lewis provided proposed language to the TG for consideration. SWMA recommended that this be an Informational item.

SWMA 2013 Annual Meeting: The region supported moving forward the modified language as it appears in their 2013 final report as a Voting item to NCWM.

Additional letters, presentations, and data may have been part of the Committee’s consideration. To review the supporting documentation, please refer to the *Report of the 98 National Conference on Weights and Measures* (SP 1171, 2013).

237-10 V Section 3.XX. Diesel Exhaust Fluid (DEF).

(This item was Adopted.)

Source:

American Petroleum Institute (2014)
(Note: In the 2014 NCWM Publication 15, this was Item 232-8)

Purpose:

To include Diesel Exhaust Fluid (DEF) in NIST Handbook 130, including defining DEF and outlining marking requirements to provide information to consumers of DEF.

Item under Consideration:

Amend NIST Handbook 130, Uniform Engine Fuels and Automotive Lubricants Regulation as follows:

Section 1. Definitions

1.14. Diesel Exhaust Fluid. – A preparation of aqueous urea [(NH₂)₂CO], containing 32.5% by mass of technically-pure urea in high-purity water with quality characteristics defined by the latest version of ISO 22241, “Diesel engines - NOx reduction agent AUS 32.”

(Added 2014)

Section 2. Standard Fuel Specifications

2.18. Diesel Exhaust Fluid (DEF). – Shall meet the latest version of ISO 22241, “Diesel engines – NOx reduction agent AUS 32.”

(Added 2014)

Section 3. Classification and Method of Sale of Petroleum Products

3.16. Diesel Exhaust Fluid (DEF).

3.16.1. Labeling of Diesel Exhaust Fluid. – Diesel Exhaust Fluid shall be labeled.

3.16.1.1. Retail Dispenser Labeling. – A label shall be clearly and conspicuously placed on the front panel of the Diesel Exhaust Fluid dispenser stating “for operation of selective catalytic reduction (SCR) converters in motor vehicles with diesel engines.”

3.16.1.2. Documentation for Retailers of Bulk Product. – A DEF supplier shall provide, at the time of delivery of the bulk shipment of DEF, identification of the fluid’s origin including the name of the fluid manufacturer, the brand name, trade name, or trademark, and a statement identifying the fluid as DEF conforming to specifications given in the latest version of ISO 22241, “Diesel engines – NOx reduction agent AUS 32.”. This information shall be provided by the supplier on an invoice, bill of lading, shipping paper, or other document.

3.16.1.3. Labeling of Packaged Product. – Any diesel exhaust fluid retail package shall bear a label that includes the name of the fluid manufacturer, the brand name, trade name, or trademark, a statement identifying the fluid as DEF conforming to specifications given in the latest version of ISO 22241, “Diesel engines – NOx reduction agent AUS 32.” and the statement, “It is recommended to store DEF between – 5 °C to 30 °C (23 °F to 86 °F).”

3.16.1.4. Documentation for Bulk Deliveries. – A carrier that transports or accepts for transportation any bulk shipment by tank truck, freight container, cargo tank, railcar, or any other vehicle used to transport or deliver bulk quantities of DEF shall, at the time of delivery of the DEF, provide identification of the fluid’s origin including the name of the fluid manufacturer, the brand name, trade name, or trademark, and a statement identifying the fluid as DEF conforming to specifications given in the latest version of ISO 22241, “Diesel engines – NOx reduction agent AUS 32.”. This information shall be provided to the recipient on an invoice, bill of lading, shipping paper, or other document.

Effective date shall be January 1, 2016

(Added 2014)

Background/Discussion: Diesel exhaust fluid (DEF) is an aqueous mixture of 32.5 % high-purity urea and 67.5 % deionized water, and is used in conjunction with Selective Catalytic Reduction (SCR) systems to remove harmful NOx emissions from diesel engines. In January 2010, the U.S. Environmental Protection Agency (EPA) enacted new emission standards requiring medium- and heavy-duty diesel vehicles to significantly reduce engine emissions, including NOx. A majority of engine manufacturers is now using SCR systems to meet the new EPA standards in their diesel applications and is specifying the use of DEF meeting the quality requirements of the most current version of ISO 22241, “Diesel engines - NOx reduction agent AUS 32- Parts 1-5.”

As a result, the sale of DEF has become a fast-growth, emerging market as pre-2010 on- and off-highway equipment inventory continues to turn over. For instance, DEF may currently be purchased at fuel-island pumps at over 1000 locations nationwide, with many more locations expected in the near future. The sale of DEF can be expected to continue to grow very quickly as additional fleet turnover occurs and regulations for passenger cars, light-duty trucks, non-road vehicles, and stationary diesel engines are phased in during the coming years. Hence, it is of utmost importance that consumers of DEF are receiving the proper information about the product they purchasing as well as assurances that the product meets the ISO 22241, “Diesel engines - NOx reduction agent AUS 32” specifications.

NCWM 2014 Interim Meeting: A representative with API provided FALS with modified language. This language will address the regional concerns regarding the clarity of the language and providing for retail dispenser labeling. This modification also expanded the recommended temperature ranges and is consistent with the ISO method. FALS concurs with the changes and submitted them to the Committee as a Voting item.

NCWM 2014 Annual Meeting: The Committee heard support that a provision should be made to make this item effective January 2016. The Committee agreed to modify the language in its Interim Report to that shown in this Final Report in the Item Under Consideration.

Regional Associations Comments:

CWMA 2014: An ISO specification currently exists for this product, and quality assurance is important. At the CWMA Annual Meeting, the Committee was informed that there is also a companion Item 232-7. An industry representative supports both items. A regulator has been working through the ASTM process to develop a specification for this product, but ASTM has decided to not pursue it. Consequently, he urges support and passage of this item. After discussion among the attendees, consensus was reached that an implementation date of one year after passage would allow sufficient time for the regulated industry to comply. The Committee is also recommending a proposed effective date be placed into the item that reflects an effective date of one year after publication. CWMA L&R Committee believes that a specification for this product is important, since ASTM is not going to develop a specification, this item should move forward as a Voting item.

WWMA heard from a representative of API regarding both Items 232-6 and 232-7 simultaneously. API explained that there is currently no definition of DEF. API also stated the sale of DEF will continue to increase in the market, as it is in use on all selective catalytic reduction diesel vehicles. He stated the method to manufacture DEF may differ, but the standard remains the same for all DEF products and purity is important. The FALS Chairman stated that ASTM does not have a specification, so the ISO specification is appropriate and would like to make this a Voting item. An industry representative from Gilbarco spoke to the uncertainty whether current receipt technology has the capability to print all required information. An industry representative expressed concern regarding temperatures requirements because of storage locations outside the specified range. The Committee supports this item and would like clarification regarding whether current receipt dispenser technology can accommodate proposed requirements. WWMA forwarded this item to NCWM and recommended it be an Informational item.

NEWMA heard a comment from the submitter that adding DEF to NIST Handbook 130, including defining DEF and outlining marking requirements would provide information to consumers of DEF. NEWMA forwarded it to NCWM, recommending it as a Developing item. At the 2014 NEWMA Annual Meeting, they recommended that this be a Voting item as it is fully developed.

SWMA forwarded the item to NCWM, recommending it as a Developing item to further address the concerns of quality statements on receipts and dispensers.

Additional letters, presentations, and data may have been part of the Committee's consideration. To review the supporting documentation, please refer to the *Report of the 98th National Conference on Weights and Measures* (SP 1171, 2013).

237-11 V Section 2.12. Motor Oil

(This item was Adopted.)

Source:

Fuels and Lubricants Subcommittee and API (2014)

(Note: This item did not appear in the 2014 NCWM Publication. This was submitted as an editorial change through FALS.)

Purpose:

Editorial change under Section 2.12.(a) Motor Oil that allows for the language insertion to include Automobile Manufacturers' Association (ACEA) "European Oil Sequences."

Item Under Consideration:

2.12. Engine (Motor) Oil. – Shall not be sold or distributed for use unless the product conforms to the following specifications:

- (a) performance claims listed on the label shall be evaluated against the latest version of SAE J183, “Engine Oil Performance and Engine Service Classification,” ~~(Other than “Energy Conserving,” API 1509 “Engine Oil Licensing and Certifications System,” API 1509 “Engine Oil Licensing and Certification System”, European Automobile Manufacturers’ Association (ACEA) “European Oil Sequences”~~ or other ~~industry~~ standards as applicable;
- (b) the product shall meet its labeled viscosity grade specification as specified in the latest version of SAE J300, “Engine Oil Viscosity Classification.”; ~~and~~
- ~~(c) any engine oil that is represented as “energy conserving” shall meet the requirements established by the latest version of SAE J1423, “Classification of Energy Conserving Engine Oil for Passenger Cars, Vans, Sport Utility Vehicles, and Light Duty Trucks.~~

(Added 2004) (Amended 2014)

Background/Discussion:

Mr. Kevin Ferrick (API) provided editorial changes through the FALS that provided clarity and aligns with similar items in the handbook. The FALS agreed to send this to the Committee recommending it as a Voting item.

2014 NCWM Interim Meeting: The Committee was informed by FALS that an editorial change to Section 2.12. Motor Oil was needed to add the European Automobile Association “European Oil Sequences” to align with proposed language in Item 232-4 and 237-6. The Committee concurs with this change.

2014 NCWM Annual Meeting: There was an editorial change to remove the word “industry” from Section 2.2.(a). The Committee agreed to modify the language in its Interim Report to that shown in this Final Report in the Item Under Consideration.

2014 NEWMA Annual Meeting: It was recommended that the language as it currently appears in the agenda be a Voting item.

Regional Associations Comments:

2014 CWMA Annual Meeting: An industry representative indicated support for this item with the following change (2.12. Motor Oil, Section (a) add words “vehicle or engine manufacturer”). The CWMA L&R Committee feels this item has been fully developed and is ready for Voting as amended.

- (a) performance claims listed on the label shall be evaluated against the latest version of SAE J183, “Engine Oil Performance and Engine Service Classification,” ~~(Other than “Energy Conserving,” API 1509 “Engine Oil Licensing and Certifications System,” API 1509 “Engine Oil Licensing and Certification System”, European Automobile Manufacturers’ Association (ACEA) “European Oil Sequences”~~ or other industry, vehicle or engine manufacturer standards as applicable; the product shall meet its labeled viscosity grade specification as specified in the latest version of SAE J300, “Engine Oil Viscosity Classification.”

The CWMA L&R Committee agrees with the amended language, believes this item has been fully developed and is ready for Voting as amended.

Additional letters, presentations, and data may have been part of the Committee’s consideration. To review the supporting documentation, please refer to the *Report of the 98th National Conference on Weights and Measures* (SP 1171, 2013).

260 NIST HANDBOOK 133

260-1 W Section 3.10. Animal Bedding

(This item was Withdrawn.)

Source:

Central Weights and Measures Association (2012)

Purpose:

This proposal is to clarify appropriate test procedures for animal bedding.

Item Under Consideration:

Amend NIST Handbook 133, Test Procedures – For Packages Labeled by Volume as follows:

3.10. ~~Mulch, and Soils, and Animal Bedding~~ Labeled by Volume.

Mulch is defined as “any product or material except peat or peat moss that is advertised, offered for sale, or sold for primary use as a horticultural, above-ground dressing, for decoration, moisture control, weed control, erosion control, temperature control, or other similar purposes.”

Soil is defined as “any product or material, except peat or peat moss that is advertised or offered for sale, or sold for primary use as a horticultural growing media, soil amendment, and/or soil replacement.”

Animal bedding is defined as “any product or material, except for baled straw or peat moss, that is advertised, offered for sale, or sold for primary use as a medium for animals to bed, nest or eliminate waste, such as compressed wood pulp or cellulose fibers (confetti, granules, or pellets), softwood shavings, shredded paper, compressed coconut fiber, ground corn cob, pelleted paper or wheat straw, cotton fibers, and bamboo products or any other material.” Animal bedding as “animal bedding of all kinds, except for baled straw”

3.10.1. Test Equipment.

- A test measure appropriate for the package size that meets the specifications for test measures in Table 3-4. “Specifications for Test Measures for Mulch, ~~and~~ Soils and **Animal Bedding**”
- Drop cloth/polyethylene sheeting for catching overflow of material
- Level (at least 15 cm [6 in] in length)

**Table 3-4.
Specifications for Test Measures for Mulch, and Soils, and Animal Bedding**

Nominal Capacity of Test Measure ⁴	Actual Volume of the Measure ⁴	Interior Wall Dimensions ¹			Marked Intervals on Interior Wall ³	Volume Equivalent of Marked Intervals
		Length	Width	Height ²		
30.2 L (1.07 cu ft) for testing packages that contain less than 28.3 L (1 cu ft or 25.7 dry qt)	31.9 L (1.13 cu ft)	213.4 mm (8.4 in)	203.2 mm (8 in)	736.6 mm (29 in)	12.7 mm (½ in)	550.6 mL (33.6 in ³)
28.3 L (1 cu ft)	28.3 L (1 cu ft)	304.8 mm (12 in)	304.8 mm (12 in)	304.8 mm (12 in)		1179.8 mL (72 in ³)
56.6 L (2 cu ft)	63.7 L (2.25 cu ft)	304.8 mm (12 in)	304.8 mm (12 in)	685.8 mm (27 in)		
		406.4 mm (16 in)	228.6 mm (9 in)	685.8 mm (27 in)		
84.9 L (3 cu ft)	92 L (3.25 cu ft)	304.8 mm (12 in)	304.8 mm (12 in)	990.6 mm (39 in)		
		406.4 mm (16 in)	228.6 mm (9 in)	990.6 mm (39 in)		

Measures are typically constructed of 1.27 cm (½ in) marine plywood. A transparent sidewall is useful for determining the level of fill, but must be reinforced if it is not thick enough to resist distortion. If the measure has a clear front, place the level gage at the back (inside) of the measure so that the markings are read over the top of the mulch.

Notes

¹ Other interior dimensions are acceptable if the test measure approximates the configuration of the package under test and does not exceed a base configuration of the package cross-section.

²The height of the test measure may be reduced, but this will limit the volume of the package that can be tested.

³When lines are marked in boxes, they should extend to all four sides of the measure if possible to improve readability. It is recommended that a line indicating the MAV level also be marked to reduce the possibility of reading errors when the level of the mulch is at or near the MAV.

⁴The Nominal Capacity is given to identify the size of packages that can be tested in a single measurement using the dry measure with the listed dimensions. It is based on the most common package sizes of mulch in the marketplace. If the measures are built to the dimensions shown above the actual volume will be larger than the nominal volume so that plus errors (overfill) can be measured accurately.

(Amended 2010 **and 20XX**)

3.10.2. Test Procedure.

1. Follow the Section 2.3.1. “Define the Inspection Lot.” Use a “Category A” sampling plan in the inspection, and select a random sample.

2. Open each package in turn. Empty the contents of the package into a test measure and level the contents by hand. Do not rock, shake, drop, rotate, or tamp the test measure. Read the horizontal marks to determine package net volume.

Note: Mulch: Some types of mulch are susceptible to clumping and compacting. Take steps to ensure that the material is loose and free flowing when placed into the test measure. Gently roll the bag before opening to reduce the clumping and compaction of material.

Compressed state animal bedding: To measure the usable volume, first empty the contents of the package on a drop cloth. Using your hands, or a tool if necessary, loosen the material until it is free of all clumps and compaction. When the product is free flowing, place in a test measure. To determine volume of the compressed state animal bedding, follow Section 3.9.1. Compressed Volume Packages.

3. Exercise care in leveling the surface of the mulch/soil/**animal bedding** and determine the volume reading from a position that minimizes errors caused by parallax.
4. Determine package errors by subtracting the labeled volume from the package net volume in the measure. Record each package error.

$$\text{Package Error} = \text{Package Net Volume} - \text{Labeled Volume}$$

3.10.3. Evaluation of Results.

Follow the procedures in Section 2.3.7. “Evaluate for Compliance to determine lot conformance.

Note: In accordance with Appendix A, Table 2-10. Exceptions to the Maximum Allowable Variations for Textiles, Polyethylene Sheeting and Film, Mulch and Soil Labeled by Volume, Packaged Firewood, and Packages Labeled by Count with 50 Items or Fewer, and Specific Agricultural Seeds Labeled by Count, apply an MAV of 5 % of the declared quantity to mulch, ~~and~~ soil **and animal bedding** sold by volume. When testing mulch and soil with a net quantity in terms of volume, one package out of every 12 in the sample may exceed the 5 % MAV (e.g., one in a sample of 12 packages; two in a sample of 24 packages; four in a sample of 48 packages). However, the sample must meet the average requirement of the “Category A” Sampling Plan.

Table 2-10. Exceptions to the Maximum Allowable Variations for Textiles, Polyethylene Sheeting and Film, Mulch, and Soils, and Animal Bedding Labeled by Volume, Packaged Firewood, and Packages Labeled by Count with 50 Items or Fewer, and Specific Agricultural Seeds Labeled by Count.	
	Maximum Allowable Variations (MAVs)
Mulch, And Soil, and Animal Bedding Labeled By Volume	<p>The MAVs are:</p> <p>For individual packages: 5 % of the labeled volume.</p> <p>For example: One package may exceed the MAV for every 12 packages in the sample (e.g., when the sample size is 12 or fewer, 1 package may exceed the MAV and when the sample size is 48 packages, 4 packages may exceed the MAV).</p> <p><u>NOTE: For Animal Bedding there is a temporary exemption not to apply the MAV. After July 2017, there will be an MAV of 5 % of the labeled volume applied to “animal bedding.”</u></p>

(Amended 2010)

Background/Discussion:

NIST Handbook 130, Uniform Regulation for the Method of Sale, Section 2.23. Animal Bedding states:

2.23. Animal Bedding. – Packaged animal bedding of all kinds, except for baled straw, shall be sold by volume, that is, by the cubic meter, liter, or milliliter and by the cubic yard, cubic foot, or cubic inch. If the commodity is packaged in a compressed state, the quantity declaration shall include both the quantity in the compressed state and the usable quantity that can be recovered.

Example:

250 mL expands to 500 mL (500 in³ expands to 1000 in³).

(Added 1990) (Amended 2012)

However, NIST Handbook 133 does not include specific procedures for testing animal bedding volume declarations, compressed state quantity declarations, or usable quantity declarations. This proposal is to clarify appropriate test procedures for animal bedding.

NCWM 2012 Interim Meeting: The Committee made minor editorial changes to align the proposal with the format and language currently in NIST Handbook 133. The submitter had the word “uncompressed” added under the note section within “Evaluation of Results.” The Committee agreed and recommended to remove this word.

This proposal includes adopting both the mulch and soil test method and the evaluation of results for animal bedding. The method of evaluating results for mulch and soil testing includes an exception to the maximum allowable variation (MAV), the MAV is 5%, and one package out of a 12 item sample (two packages in 24 item sample, four packages in a 48 item sample) is allowed to exceed the MAV. However, the sample must meet the average requirement of “Category A.” This MAV exception for mulch and soil was developed based on a study of mulch and soil test results. The Committee will ask industry to submit animal bedding product information and test data to determine if the MAV exception is appropriate for animal bedding.

An animal bedding industry representative was supportive of the 5 % allowance and also recommended a 12 × 12 × 12 cu ft vessel. The submitter of the proposal has been using the mulch test procedure to test animal bedding and has not had issues using the procedure under the item for consideration. The 2012 Committee designated this item as an Informational item.

NCWM 2012 Annual Meeting: The Committee requested that regulators and industry conduct animal bedding package testing, and submit their test results to Ms. Cardin at judy.cardin@wi.gov or to Mr. David Sefcik at dsefcik@nist.gov. Preliminary analysis by NIST of available test data indicates that an exception for MAV is necessary for this product, but the Committee needs additional test data to determine the appropriate amount for that exception.

NCWM 2013 Interim Meeting: Mr. David Sefcik (NIST, OWM) provided a summary of the data that was received from states and manufacturers that tested animal bedding. The findings were limited participation, and very few lots passed; therefore, NIST could not make a recommendation for a MAV. Data shows there is a bigger concern than determining correct MAV. Even with applying a 5 % MAV, almost all the lots would have failed. There were also significant variations in labeled content, variability on bedding materials, different types of packing machines and volumetric test measures. It was agreed the test procedure for mulch could be used for animal bedding. The recommendation was that the Committee should consider a temporary exemption from the MAV (three to five years). This would provide an exemption from the current MAV which is too restrictive while giving the Committee and NIST additional time for data to be collected to determine the proper MAV. NIST will work with stakeholders to develop a standardized test measure.

Mr. Jim Byers (San Diego County, California) expressed concern that animal bedding needs to be clearly defined. Mr. Byers submitted recommended language to define animal as follows:

“Any product or material, except for baled straw, that is advertised, offered for sale, or sold for primary use as a medium for animals to bed, nest or eliminate waste, such as compressed wood pulp or cellulose fibers (confetti, granules, or pellets), softwood shavings, shredded paper, compressed coconut fiber, ground corn cob, pelleted paper or wheat straw, cotton fibers, and bamboo products or any other material.”

Mr. Floren agrees with Mr. Byers and Mr. Sefcik on their recommendations. Mr. Rich Whiting (American Wood Fibers) spoke that they participated and their lots did not pass. American Wood Fibers would like to see a test measure and quantity control practices developed by NCWM.

The Committee agrees with the definition for animal bedding drafted by Mr. Byers with the addition of peat moss as an exemption. It was agreed to remove the MAV requirement for animal bedding and the Committee is recommending that the states test animal bedding on the “average requirement.” The removal of the MAV for animal bedding would be a temporary exemption for a four year period, after which time the MAV would default to the 5 %. There was no objection from NIST on the test procedure. Information will need to be obtained from industry to determine an accurate test measure. It was also agreed to put a sunset date of July 2017 into the language. With these changes, the Committee proposes this as a Voting item.

NCWM 2013 Annual Meeting: A regulator opposed the item as written due to animal bedding is being defined within a test procedure for mulch and soil. He questions how the 5 % MAV was calculated. He also does not recommend a fix of applying a temporary MAV exemption. The Committee concurs that this item is not ready to move forward as a Voting Item and moved this item to Developing status, so the submitter can further develop. The definition needs to be reviewed to determine any exemptions that may apply for items currently sold by weight. Reconsideration should also be given to whether a three-year exemption to the MAV is appropriate. The Committee believes this item needs to be further developed and returned to the submitter.

NCWM 2014 Interim Meeting: There were no comments heard and there has been no response from the submitter to further develop. A NIST Technical Advisor responded that NIST will continue to gather data and study this issue. If NIST believes there is an issue, they will submit a new proposal. The Committee is recommending this be a Withdrawn item since no additional work by the submitter has been done.

Regional Association Comments:

CWMA commented that no additional information has been received to date. During past regional meetings, a state regulator noted there is no standard for animal bedding, and industry is using a variety of test methods, which produce varying results. Wisconsin tested and found a wide variance in net quantity accuracy and found significant shortages in several instances. Ms. Cardin encouraged other jurisdictions to test animal bedding and to share data

with NIST, OWM. Missouri did a lot of testing at one facility and found a maximum of 36 % shortage and an average of 23 % shortage. Missouri's analysis further showed that the chipper had a great impact of the "spring effect" of compression. An industry representative recommended developing a method of sale for this commodity when sold from bulk since a significant amount of horse bedding is purchased in bulk. Ms. Cardin announced she would coordinate an animal bedding package testing survey to provide data to determine the appropriate exception to MAV for animal bedding. Some states agreed to participate. During the most recent annual meeting (2013), the NIST Technical Advisor remarked that the date in the MAV table was open ended and consideration should be given to make it date specific. NIST continues to analyze test data, and states should continue to send test data to NIST. During their May 2013 Annual Meeting, the Committee recommended that a date for the temporary exemption read July 1, 2017, and recommended Voting status. At the 2013 CWMA Interim Meeting, they recommended that the item be a Developing item.

WWMA received comment from a regulatory official stating that the submitter is unlikely to continue work on this item; however, a national test procedure on animal bedding is needed. First, the definition for animal bedding needs to be reworked. The definition in Section 3.10. Mulch and Soils Labeled by Volume, needs to specifically address compressible materials only or "products subject to compression." In Section 3.10.2., Test Procedure is contradictory because the definition specifically excludes peat moss, yet the test procedure references Section 3.9.1. Compressed Volume Packages Applied to Peat Moss. Third, there is no data to justify a 5 % MAV. The Committee believed this item has merit and should be further developed. WWMA recommended that it be a Developing item.

NEWMA commented in 2012 that it would like to see results of the CWMA study before action is taken on the proposal. NEWMA recommended that the item be an Informational item. During the 2013 NEWMA Annual Meeting, the NIST Technical Advisor remarked that they continue to collect data on this subject matter. The Committee believed there is sufficient data to support this item and recommended it as a Voting item. At their 2013 Interim Meeting, reviewed the comments from the report of the WWMA and recommended that the item be a Developing item.

SWMA heard comments in 2012 from a NIST Technical Advisor that the chair of the NCWM L&R Committee is requesting states to participate in the package testing of animal bedding over the next two months in order to provide more data to help determine the appropriate MAV. SWMA recommended that the item be an Informational item unless there is strong evidence from the survey for an appropriate MAV, in which case SWMA would recommend it as a Voting item. At the 2013 SWMA Annual Meeting, they supported the item remaining as a Developing item as it needs more work.

Additional letters, presentations, and data may have been part of the Committee's consideration. To review the supporting documentation, please refer to the *Report of the 98th National Conference on Weights and Measures* (SP 1171, 2013).

260-2 V Section 3.12. Fresh Oysters Labeled by Volume

(This item was Adopted.)

Source:

NIST Office of Weights and Measures (2014)

Purpose:

To correct errors and omissions to NIST Handbook 133, Section 3.12., Fresh Oysters Labeled by volume so that it is in complete agreement with the AOAC Official Method 35.1.07 (953.11), which is utilized by the Food and Drug Administration.

Item under Consideration:

Amend NIST Handbook 133 as follows:

3.12. Fresh Oysters Labeled by Volume.

Packaged fresh oysters removed from the shell must be labeled by volume. The maximum amount of permitted free liquid is limited to 15 % by weight. Testing the quantity of contents of fresh oysters requires the inspector to determine total volume, total weight of solids and liquid, and the weight of the free liquid.

3.12.1. Test Equipment.

- A scale that meets the requirements in Section 2.2. “Measurement Standards and Test Equipment”
- Volumetric measures
- Micrometer depth gage (ends of rods fully rounded), 0 mm to 228 mm (0 in to 9 in)
- Strainer for determining the amount of drained liquid from shucked oysters. Use ~~as~~ a strainer and a slightly smaller flat bottom ~~metal~~ receiving pan or tray constructed to the following specifications:
 - Sides: 5.08 cm (2 in)
 - Area: 1935 cm² (300 in²) or more for each 3.78 L (1 gal) of oysters

Note: Strainers of smaller area dimensions are permitted to facilitate testing smaller containers.

- Perforations:
 - Diameter: 6.35 mm (¼ in)
 - Location: 3.17 cm (1¼ in) apart in a square pattern, or perforations of equivalent area and distribution.
- Spanning bar, 2.54 cm by 2.54 cm by 30.48 cm (1 in by 1 in by 12 in)
- Rubber spatula
- Thermometer, 1 °C (2 °F) graduations and a range of – 35 °C to + 50 °C (– 30 °F) to + 120 °F) accurate to ± 1 °C (± 2 °F)
- Level, at least 15.24 cm (6 in) in length
- Stopwatch

3.12.2. Test Procedure.

Note: Test the oysters at a temperature of 7 (± 1) °C [45(± 2) °F].

1. Follow the Section 2.3.1. “Define the Inspection Lot.” Use a “Category A” sampling plan in the inspection; and select a random sample.
2. Determine and record the gross weight of a sample package.
3. Set the container on a level surface and open it. Use a depth gage to determine the level of fill. Lock the depth gauge. Mark the location of the gauge on the package.
4. Weigh a dry ~~20.32 cm or 30.48 cm (8 in or 12 in)~~ receiving pan and record the weight. Set strainer over the receiving pan.
5. Pour the contents from the container onto the strainer without shaking it. ~~Tip the strainer slightly and let it d-~~Drain for two minutes. Remove strainer with oysters. It is normal for oysters to

include mucous (which is part of the product) that will not pass through the strainer, so do not force it.

6. Weigh the receiving pan and liquid and record the weight. Subtract the weight of the dry receiving pan from the weight of pan and liquid to obtain the weight of free liquid and record the value.
7. Clean, dry, and weigh the container and record the tare weight. Subtract the tare weight from the gross weight to obtain the total weight of the oysters and liquid and record this value.
8. Determine and record the percent of free liquid by weight as follows:

Note: This handbook provides a Worksheet for Determining the Free Liquid and Net Volume of Oysters in Appendix C.

Percent of free liquid by weight = [(weight of free liquid) ÷ (weight of oysters + liquid)] × 100,

or

$(f \div c) \times 100 = \text{Percentage of Free Liquid by Weight}$

Where:

$f = \text{Weight of Free Liquid}$

$c = (\text{Net Weight of Oysters} + \text{Liquid})$

9. Set up the depth gauge on the dry package container as in Step 3. Pour water from the flasks and graduate as needed to re-establish the level of fill obtained in Step 3. Add the volumes delivered as the actual net volume for the container and record the value.

Note: Some containers will hold the declared volume only when filled to the brim; they may have been designed for other products, rather than for oysters. If the net volume is short measure (per Step 9), determine if the container will reach the declared volume only if filled to the brim. Under such circumstance, the package net volumes will all be short measure because the container cannot be filled to the brim with a solid and liquid mixture. A small headspace is required in order to get the lid into the container without losing any liquid.

(Amended 2014)

Background/Discussion:

In preparing a new presentation on oyster testing for the NIST Handbook 133 Basics class, to be held in North Carolina, the Office of Weights and Measures compared the test methods used by the Food and Drug Administration (FDA), which are published by AOAC International (AOAC), to the test procedure in Section 3.12., Fresh Oysters Labeled by Volume. This review revealed that the test procedure in NIST Handbook 133 did not include the AOAC requirement that the oysters be tested at a specified temperature, or the description of the receiving pan in the list of test equipment. Also, Step 4 of the test procedure was inaccurate. NIST OWM also found the HB133 requirement that the strainer be “tipped slightly” (refer to Step 5) to be ambiguous and it is not included in the AOAC procedure. NIST OWM believes these errors most likely occurred when the 4th Edition of NIST Handbook 133 was revised to replace the original sieve requirements with the AOAC equipment requirements that were in response to the requirements of the Nutrition Labeling and Education Act (NLEA). NLEA requires that state and local regulations (and test procedures) be identical to those used by FDA.

To bring NIST Handbook 133, Section 3.12., Fresh Oysters Labeled by Volume into agreement with the AOAC Official Method 35.1.07 (953.11), the following revisions are proposed:

1. Revise the description of the receiving pan in Section 3.12.1. to clarify that it is to be slightly smaller than the strainer.

2. Add a note in Section 3.12.2. Test Procedure regarding the temperature at which the oysters must be tested.
3. Delete the incorrect references to circular receiving pans (i.e., 8 in and 12 in) in Section 3.12.2. Test Procedure, Step 4.
4. Delete the instruction to “tip the strainer slightly” in Section 3.12.2. Test Procedure, Step 5 to eliminate the ambiguous guidance which conflicts with the AOAC method.
5. Add a simpler version of the formula in Section 3.12.2. Test Procedure, Step 8 which can be used in the Worksheet for Determining the Free Liquid and Net Volume of Oysters.
6. Add a Worksheet for Determining the Free Liquid and Net Volume of Oysters to NIST Handbook 133, Appendix C., Model Inspection Report Forms. This worksheet was created to aid the inspector in conducting the test and documenting the actual test values. It was adapted from the oyster worksheet adopted in 1990 and published in the 3rd Supplement to the 3rd Edition of NIST Handbook 133.

In 1997, the State of North Carolina shared its drawings of the AOAC strainer with OWM and those drawings have been reformatted and made available for free download at: www.nist.gov/pml/wmd/pubs/hb133-13.cfm.

The Federal Food Drug and Cosmetic Act requires the use of net quantity test procedures and equipment identical to those used by the Food and Drug Administration which are contained in AOAC International test methods.

This proposal corrects previous errors and omissions and eliminates a conflict with an FDA test method. NIST OWM does not believe there is any reason to object to the proposed revisions. Some jurisdiction may object to adding another worksheet to NIST Handbook 133. NIST OWM will make the form available on the Office of Weights and Measures web page. (See Appendix B).

2014 Interim Meeting: A NIST Technical Advisor remarked that this test procedure and equipment was performed at a NIST Handbook 133 training course and there were no issues or concerns. The Committee moved this forward as a Voting item. 2014 NCWM Annual Meeting: No comments heard. The NIST Technical Advisor made an editorial change, adding a note to Step 8 to reference the location of the Worksheet for Determining the Free Liquid and Net Volume of Oysters.

Regional Association Comments:

CWMA’s L&R Committee agrees with NIST, clarification of language should be harmonized. CWMA forwarded the item to NCWM, recommending it as a Voting item. At the 2014 CWMA Annual Meeting no comments were received at the L&R Committee Open Hearings. The Committee believes this proposal will correct errors and omissions, so that the provision in NIST Handbook 133 is aligned with the AOAC Official Method 35.1.07 (953.11), which is utilized by the Food and Drug Administration. Consequently, the CWMA L&R Committee believes the item has been fully developed and is ready for Voting.

WWMA heard from a NIST technical advisor who stated that this item is intended to correct errors and omissions to the test procedure in NIST Handbook 133 so that it brings the item in agreement with AOAC Official Method 35.1.07 (953.11) which is utilized by FDA. The proposal also includes a worksheet developed by NIST which would appear in the NIST Handbook 133 Appendix. The Committee believes the item has merit, and it is fully developed. WWMA forwarded the item to NCWM and recommended that it be a Voting item.

NEWMA 2013 Interim Meeting: NEWMA commented that the language corrects technical errors and forward the item to NCWM recommending the item as Voting.

NEWMA 2014 Annual Conference: The Committee recommends this as a Voting item in order to be consistent with federal regulations. NEWMA commented that the language corrects technical errors and forwarded the item to NCWM.

SWMA supported the item as proposed and forwarded the item to NCWM, recommending that it be a Voting item as it aligns weights and measures and FDA inspection procedures.

Additional letters, presentations, and data may have been part of the Committee's consideration. To review the supporting documentation, please refer to the *Report of the 98th National Conference on Weights and Measures* (SP 1171, 2013).

260-3 W Section 4.3. Paper Plates and Sanitary Paper Products

(This item was Withdrawn.)

Source:

Georgia Pacific (2013)

Purpose:

Add a more accurate & reproducible test method for verifying dimensions of disposable plates, bowls, and platters.

Item Under Consideration:

Amend NIST Handbook 133 as follows:

4.3. Paper Plates and Sanitary Paper Products

The following procedure is used to verify the size of paper plates and other sanitary paper products. It may also be used to verify the size declarations of other disposable dinnerware.

Note: Do not distort the item's shape during measurement.

The count of sanitary paper products cannot be adequately determined by weighing. Variability in sheet weight and core weight requires that official tests be conducted by actual count. However, weighing can be a useful audit method. These products often declare total area as well as unit count and sheet size. If the actual sheet size measurements and the actual count comply with the average requirements, the total area declaration is assumed correct.

4.3.1. Test Equipment.

- Steel tapes and rules. Determine measurements of length to the nearest division of the appropriate tape or rule.
 - Metric Units:

For labeled dimensions 40 cm or less, linear measure: 30 cm in length, 1 mm divisions; or a 1 m rule with 0.1 mm divisions, overall length tolerance of 0.4 mm.

For labeled dimensions greater than 40 cm, 30 m tape with 1 mm divisions.
 - Inch-pound Units:

For labeled dimensions 25 in or less, use a 36 in rule with $\frac{1}{64}$ in or $\frac{1}{100}$ -in divisions and an overall length tolerance of $\frac{1}{64}$ in.

For dimensions greater than 25 in, use a 100 ft tape with in divisions and an overall length tolerance of 0.1 in.
- Measuring Base

Note: A measuring base may be made of any flat, sturdy material approximately 38 cm (15 in) square. Two vertical side pieces approximately 3 cm (1 in) high and the same length as the sides of the measuring base are attached along two adjoining edges of the measuring base to form a 90° corner. Trim all white borders from two or more sheets of graph paper (10 divisions per centimeter or 20 divisions per inch). Place one sheet on the measuring base and position it so that one corner of graph paper is snug in the corner of the measuring base and vertical sides. Tape the sheet to the measuring base. Overlap other sheets on the first sheet so that the lines of top and bottom sheet coincide, expanding the graph area to a size bigger than plates to be measured; tape these sheets to the measuring base. Number each line from the top and left side of base plates: 1, 2, 3, etc.

- **Plate Dimension Tester**

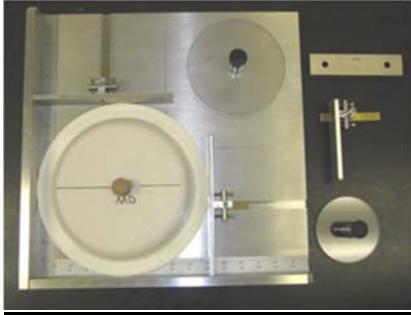

4.3.2. Test Procedure

- 1.* Follow Section 2.3.1. “Define the Inspection Lot.” Use a “Category A” sampling plan in the inspection; select a random sample.
- 2.* Select an initial tare sample according to Section 2.3.5.1. “Determination of Tare Sample and Average Tare Weight.”
3. Open each package and select one item from each.

Note: Some packages of plates contain a combination of different-sized plates. In this instance, take a plate of each declared size from the package to represent all the plates of that size in the package. For example, if three sizes are declared, select three different plates from each package.

Note: Occasionally, packages of plates declared to be one size contain plates that can be seen by inspection to be of different sizes in the same package. In this instance, select the smallest plate and use the methods below to determine the package error. If the smallest plate is not short measure by more than the MAV, measure each size of plate in the package and calculate the average dimensions.

Example:

If five plates measure 21.41 cm (8.43 in) and 15 measure 21.74 cm (8.56 in), the average dimension for this package of 20 plates is 21.66 cm (8.53 in).

4. For paper plates **bowls or platters**: Place each item on the **plate dimension tester or** measuring base plate (or use the linear measure) with the eating surface down so two sides of the plate touch the sides of the **plate dimension tester or** measuring base. **If using the plate dimension tester, follow the test procedure for determining the plate, bowl or platter size.**
5. For other products: Use either the measuring base or a linear measure to determine actual labeled dimensions (e.g., packages of napkins, rolls of paper towels). If testing folded products, be sure that the folds are pressed flat so that the measurement is accurate.

6. If the measurements reveal that the dimensions of the individual items vary, select at least 10 items from each package. Measure and average these dimensions. Use the average dimensions to determine package error in Step 7 below.
7. The package error equals the actual dimensions minus the labeled dimensions.

4.3.3. Evaluation of Results.

Follow the procedures in Section 2.3.7. “Evaluate for Compliance to determine lot conformance.

Background/Discussion:

NIST Handbook 133, Section 4.3. Paper Plates and Sanitary Paper Products, identifies “Metric” and/or “U.S. Customary Units (Inch Pound)” steel tapes and rules or a “measuring base” as acceptable equipment for doing dimensional evaluations of paper plates and sanitary paper products. This proposal would add another acceptable piece of equipment which we call the “Plate Dimension Tester.”

It is simpler, faster, and easier for an operator, technician, or regulator to use, and it is or more accurate and reproducible than the existing acceptable equipment listed in NIST Handbook 133 Section 4.3. Paper Plates and Sanitary Paper Products. For most of these types of products (11.8 in or less), the current metric rule is identified as a 30 mm rule in 1 mm divisions (0.039 in), or a 1 meter rule with 0.1 mm divisions (0.0039 in), and the inch pound rule is a 36 inch rule with $\frac{1}{64}$ or $\frac{1}{100}$ divisions (0.015 in or 0.01 in). The acceptable divisions are somewhat different. The proposed tester uses a certified steel rule with divisions of 0.02 inches which falls within the range of acceptable rules already listed in Section 4.3. Paper Plates and Sanitary Paper Products.

The measuring base described as acceptable uses graph paper with divisions of 0.05 inches. That measuring base is described and constructed as follows:

A measuring base may be made of any flat, sturdy material approximately 38 cm (15 in) square. Two vertical side pieces approximately 3 cm (1 in) high and the same length as the sides of the measuring base are attached along two adjoining edges of the measuring base to form a 90° corner. Trim all white borders from two or more sheets of graph paper (10 divisions per centimeter or 20 divisions per in). Place one sheet on the measuring base and position it so that one corner of graph paper is snug in the corner of the measuring base and vertical sides. Tape the sheet to the measuring base. Overlap other sheets on the first sheet so that the lines of top and bottom sheet coincide, expanding the graph area to a size bigger than plates to be measured; tape these sheets to the measuring base. Number each line from the top and left side of base plates: 1, 2, 3, etc.

The submitter believes the accuracy of cutting the borders off the edges of graph paper, aligning the graph paper lines to match, and then taping them in place leaves a lot to be desired for accuracy when gathering data; especially when the expectations require the values to be read to such small increments. The plates need to touch the two sides of the measuring base which require holding the plate flat against the measuring base and changes in that pressure can alter the values. The process of using rules can also cause problems when the plate edge must be perfectly aligned with the edges of the rule and then to make sure you have measured both directions in a perfect 90° angle. We, therefore, developed the Plate Dimension Tester to solve all those problems. He submitted separately pictures of the tester, a test procedure for using the tester, a video showing the use of the tester, some reproducibility data and a letter from the Foodservice Packaging Industry (FPI), which represents 85 % of the companies producing these types of products, indicating their industry Technical Committee supports this proposal. The submitter believes his method would be a positive addition to NIST Handbook 133 without changing any of regulatory requirements; simply improving on the technical accuracy and reproducibility of the resulting data generated.

The Standard Test Method as well as additional pictures, reproducibility data and a blueprint of a Plate Dimension Tester is in the *Report of the 98th National Conference on Weights and Measures* (SP 1171, 2013), Appendix F.

2012 SWMA Annual Meeting: Mr. Richard Davis (Georgia Pacific) expressed concern with that importers are not compliant and is causing unfair competition to U.S. manufacturers (e.g., a $\frac{1}{8}$ inch shortage in a paper plate can equate to over \$100,000 unfair advantage). Mr. Davis has submitted this proposal that would add an additional test method, but would not change the current test procedures (steel rule or graph paper) in NIST Handbook 133. Mr. Davis believes that this is a more accurate procedure than what is currently adopted and would provide support if challenged in court. The device has an estimated cost of \$3,000 and would be available through a third party. A video was shown describing how to operate and test. An industry official expressed concern on whether the equipment and disc can be certified and calibrated by a state lab. The Committee believes that the device would provide an additional option and improved test procedure for regulators and industry. SWMA forwarded the item to NCWM, recommending it as a Voting item.

Mr. Davis provided a presentation at the 2013 NCWM Interim Meeting provided an overview on the test standard and equipment that they are proposing to use in the test procedure. Mr. Davis believes that the item presented before the Committee will allow for greater efficiency, accuracy, repeatability, and uncertainty. This device will also allow for the testing of other products such as paper towels, napkins, and sandwich bags. Ms. Carol Hockert (NIST, OWM) volunteers to take the information to the NIST Dimensional Laboratory for further accuracy testing. The Committee feels this item is developed, and is moving this item forward as a Voting item. At the 2013 NCWM Annual Meeting, the Committee believes that additional work needs to be addressed on this item. A separate NIST Handbook 133 procedure needs to be created in order to utilize the plate dimension tester. The Technical Association of Pulp and Paper Industry (TAPPI) standard that is referenced within the procedure was not made available. The procedure title may need to reflect *bowls and platters*. The Committee is returning this item to Developing status so that the submitter can develop this item.

NCWM 2013 Annual Meeting: There was testimony heard that this item needs to be further developed. Some spoke that it is not feasible to place the Plate Dimension Tester in the current test procedure in NIST Handbook 133 (2013). The Item Under Consideration also has a TAPPI standard reference and there was not a copy of this standards available for review. The Committee agrees that this item should be returned to the submitter for further development.

NCWM 2014 Interim Meeting: The Committee heard from a NIST Technical Advisor that they are unable to contact Mr. Davis (Georgia Pacific) whom originally submitted this proposal due to his retirement. They also tried alternative personnel with Georgia Pacific and have been unsuccessful. For these reasons, the Committee is Withdrawing this item.

Regional Association Comments:

CWMA recommended that this item be Developing. At the May 2013 Annual Meeting, CWMA recommended Voting status, and agreed that this would be an improved test method. They based their recommendation on Conference comments during the 2013 NCWM Annual Meeting, and the fact that no other information was received.

WWMA heard from a regulatory official who stated that the item lacks an actual test procedure in Section 4.3.2., and references TAPPI standards that are not included in NIST Handbook 133. The item needs further clarification and development. WWMA recommended that it be a Developing item.

NEWMA received a report at its 2013 Annual Meeting from Ms. Carol Hockert (NIST OWM) that the NIST Dimensional Laboratory reported no problems with the testing device. Based on this new information NEWMA believed this item was fully developed and recommended this as a Voting item. At the 2013 NEWMA Interim Meeting, the Committee chair reported that a regulatory official stated that the item lacks an actual test procedure in Section 4.3.2., and references TAPPI standards that are not included in NIST Handbook 133. Based on the information the NCWM L&R Committee changed the status of this item from Voting to Developing in July 2013. The item needs further clarification and development. NEWMA recommended that the item be a Developing item.

SWMA reported in 2012 that Mr. Richard Davis (Georgia Pacific) expressed concern that importers are not compliant and is causing unfair competition to U.S. manufacturers (e.g., a $\frac{1}{8}$ inch shortage in a paper plate can equate to over \$100,000 unfair advantage.) Mr. Davis has submitted this proposal that would add an additional test

method but would not change the current test procedures (steel rule or graph paper) in NIST Handbook 133. Mr. Davis believes this is a more accurate procedure than what is currently adopted, and would provide support if challenged in court. The device has an estimated cost of \$3,000, and would be available through a third party. A video was shown describing how to operate and test. An industry official expressed concern on whether the equipment and disc can be certified and calibrated by a state lab. The Committee believes that the device would provide an additional option and improved test procedure for regulators and industry. SWMA forwarded the item to NCWM, recommending it as a Voting item. At the 2013 Annual Meeting, the SWMA supported the item remaining as a Developing item on the NCWM agenda, that the TAPPI standard referenced in the procedure be made available, and that the procedure for using the apparatus be developed and included.

Additional letters, presentations, and data may have been part of the Committee's consideration. To review the supporting documentation, please refer to the *Report of the 98th National Conference on Weights and Measures* (SP 1171, 2013).

270 OTHER ITEMS

270-1 D Fuels and Lubricants Subcommittee

Source:

The Fuels and Lubricants Subcommittee (2007)

Purpose:

Update the Uniform Engine Fuels, Petroleum Products, and Automotive Lubricants Regulation in NIST Handbook 130 including major revisions to fuel ethanol specifications. Another task will be to update the Basic Engine and Fuels, Petroleum Products, and Lubricants Laboratory Publication.

Item Under Consideration:

This item is under development. All comments should be directed to Dr. Matthew Curran, FALS Chair at (850) 921-1570, matthew.curran@freshfromflorida.com, or Ms. Lisa Warfield, NIST Technical Advisor at (301) 975-3308, lisa.warfield@nist.gov.

Background/Discussion:

The Subcommittee met on January 24, 2007, at NCWM Interim Meeting to undertake a review of a number of significant issues related to fuel standards. Their first project was to undertake a major review and update of the Uniform Engine Fuels, Petroleum Products, and Automotive Lubricants Regulation in NIST Handbook 130. The Subcommittee also met at the 2007 NCWM Annual Meeting and continued its work on a number of items in addition to preparing a major revision of the Fuel Ethanol Specifications.

An additional project will be to update and possibly expand the Basic Engine Fuels, Petroleum Products, and Lubricants Laboratory Publication. The Subcommittee will undertake other projects as time and resources permit.

Regional Association Comments:

CWMA supports the ongoing work of FALS.

WWMA received an update from the FALS Chair on items currently under discussion: 1) A workgroup has been formed to address organic metallic additives (MMT); 2) A proposal has been submitted to develop a quality standard for Diesel Exhaust Fluid DEF; 3) Consideration is being given to reviewing regulations in their entirety to ensure harmonization with EPA regulations and references; and 4) ATF regulations will be reviewed. Committee supports the ongoing work of the FALS.

SWMA supported the continuing work of the Fuels and Lubricants Subcommittee.

Additional letters, presentations, and data may have been part of the Committee's consideration. To review the supporting documentation, please refer to the *Report of the 98th National Conference on Weights and Measures* (SP 1171, 2013).

270-2 D Packaging and Labeling Subcommittee

Source:

Packaging and Labeling Subcommittee (2011)

Purpose:

Provide notice of formation of a new Subcommittee reporting to the L&R Committee.

Item Under Consideration:

This item is under development. All comments should be directed to Mr. Chris Guay, Packaging and Labeling Subcommittee Chair, at (513) 983-0530, guay.cb@pg.com or Mr. David Sefcik, NIST Technical Advisor at (301) 975-4868, david.sefcik@nist.gov.

Background/Discussion:

NCWM 2011 Interim Meeting: The PALS met for the first time to discuss ongoing issues and agenda items in regards to packaging and labeling regulations. There were 11 attendees that represented industry, state and county regulatory officials, and the NIST Technical Advisor.

The mission of PALS is to assist the L&R Committee in the development of agenda items related to packaging and labeling. The Subcommittee will also be called upon to provide important and much needed guidance to the regulatory and consumer packaging communities on difficult questions. PALS will report to NCWM L&R Committee. The NIST Technical Advisor reported that FTC will do a review of FPLA in 2013. The 2011 L&R Committee designated this item as a Developing item and assigned its development to PALS.

NCWM 2012 Interim Meeting: PALS met to discuss its formation and strategy. The NCWM Chairman will appoint eight voting members on the Committee to consist of four regulatory officials (one from each region) and four from industry (two retailers and two manufacturers). Mr. Guay, PALS Chair, reported that work will be done through webinar meetings to be held approximately four times a year. PALS members will be responsible for providing updates and seeking feedback on the issues at their regional meetings. Mr. Guay added that PALS will be developing proposals and providing guidance and recommendations on existing proposals as assigned by the NCWM L&R Committee. He also stressed the need and importance of having key federal agencies (FDA, FTC, and USDA) participating. The NIST Technical Advisor commented that FTC announced that they will review the FPLA in 2013. The 2012 L&R Committee designated this item as a Developing item and assigned its development to PALS.

NCWM 2012 Annual Meeting: Mr. Guay reported the Subcommittee is considering further development of the following items:

- **Additional Net Content Declarations on the Principal Display Panel** – Package net contents are most commonly determined by the product form, for example, solid products are labeled by weight, and liquid products are labeled by volume. Semi-solid products such as pastes, creams, and viscous liquids are required to be labeled by weight in the United States and by volume in Canada.
- **Icons in Lieu of Words in Packaged labeled by Count** – Can a clear, non-misleading icon take the place of the word “count” or “item name” in a net content statement? While existing Federal regulation requires regulatory label information to be in “English,” the increasing presence of multilingual labels and the growing diversity of the U.S. population suggest more consumers are served with a clear and non-misleading icon.
- **Multilingual Labels**

- **Multipacks and Bundle Packages** – The net content statements for multipacks and bundled packages of individually labeled products can be different based on the approach used to calculate them. The difference is the result of the degree of rounding for dual inch-pound and metric declarations. Using two apparently valid but different methods can yield one net content statement result, that provide better accuracy between the metric and inch-pound declarations and a different net content result which is consumer friendly.

SWMA 2012 Annual Meeting: Mr. Guay stated Item 231-1 has been assigned to PALS for a recommendation. PALS is working on a series of principles and recommendations regarding claims and statements made on packages outside of quantity statement (i.e., supplemental, quality and performance claims), on what is appropriate and what is not. PALS will recommend that Item 231-1 be Withdrawn. PALS is also looking at whether icons are appropriate as part of a quantity statement and how labeling of products with multilingual labels can be simplified. SWMA recommended that the item remain as a Developing item.

NCWM 2013 Interim Meeting: James Kohm (Director of Enforcement at the Federal Trade Commission [FTC]), briefed NCWM on the goals and objectives of FTC. Mr. Kohm gave a general overview of the Fair Packaging and Labeling Act (FPLA) and announced that it is under review in 2013.

Mr. Chris Guay provided an update on the action of PALS. PALS will be focusing on best practice principles for the various quantity and quality statements seen in the marketplace. PALS will also continue to work on the items addressed at the 2012 Annual Meeting.

NCWM 2014 Interim Meeting: Mr. Guay (PALS Chair) stated that they are awaiting an announcement from FTC in regards to updating the FPLA regulations.

Regional Association Comments:

CWMA acknowledged that PALS is still waiting on FTC to update FPLA regulations. During previous meetings, the PALS Chair stated that there is a need to prioritize labeling issues.

WWMA received an update from the PALS Chair: (1) The subcommittee is developing recommendations regarding good principles and best practice guidelines on label claims and quantity statements on packages; and (2) The subcommittee is drafting comments to FTC on recommended changes to FPLA. The Committee supports the ongoing work of the PALS.

SWMA heard in 2012 from Mr. Guay who stated that Item 231-1 has been assigned to PALS for a recommendation. PALS is working on a series of principles and recommendations regarding claims and statements made on packages outside of quantity statement (i.e., supplemental, quality and performance claims), on what is appropriate and what is not. PALS will recommend that 231-1 be Withdrawn. PALS is also looking at whether icons are appropriate as part of a quantity statement and how labeling of products with multilingual labels can be simplified. SWMA recommended that the item remain as a Developing item. At the 2013 SWMA Annual Meeting the association supported the work of the PALS remaining as a Developing item on the NCWM agenda.

Additional letters, presentations, and data may have been part of the Committee's consideration. To review the supporting documentation, please refer to the *Report of the 98th National Conference on Weights and Measures* (SP 1171, 2013).

270-3 D Moisture Allowance Task Group (MATG)

Source:

Moisture Allowance Task Group (2012)

Purpose:

Provide notice of formation of a new Task Group reporting to the Committee. This Task Group will provide additional guidance for making moisture allowances for products not listed in NIST Handbook 133.

Item Under Consideration:

This item is under development. All comments should be directed to Mr. Kurt Floren, Moisture Allowance Task Group Chair at (626) 575-5451, kflorenc@acwm.lacounty.gov or Ms. Lisa Warfield, NIST Technical Advisor at (301) 975-3308, lisa.warfield@nist.gov

Background/Discussion:

NCWM 2012 Interim Meeting: Ms. Judy Cardin, Committee Chair, will be requesting that the NCWM Board of Directors form a new Task Group to review moisture allowance. The 2012 L&R Committee designated this item as a Developing item.

NCWM 2012 Annual Meeting: Mr. Floren (Los Angeles County, California) announced that he will Chair the Moisture Allowance Task Group.

NCWM 2013 Interim Meeting: Mr. Floren announced that he is seeking a representative from each region for the MATG. He would prefer to have a representative from each region. Currently the following have regions have provided a representative; NEWMA, Mr. Frank Greene, (Connecticut) and WWMA, Mr. Brett Gurney (Utah). The following individuals have also expressed interest: Ms. Maile Hermida (Hogan Lovells US, LLP), Ms. Ann Boeckman (Kraft Foods Group), and Mr. Chris Guay (Procter and Gamble Co.). Mr. Floren remarked that meetings will be held via web-meetings and at the NCWM Conferences.

NCWM 2014 Interim Meeting: The MATG discussed how to proceed forward on this item and reviewed past history of prior work done.

Regional Association Comments:

CWMA acknowledged that a committee is being formed.

WWMA received a report from the MATG Chair that progress has been made in the formation of work group and regional representation. A teleconference will be scheduled. The Committee supports the anticipated work of MATG.

SWMA reported in 2012 that the Committee supported the formation of the moisture loss work group. SWMA recommended that the item remain as a Developing item. At the 2013 SWMA Annual Meeting, the association supported the work of the MATG remaining as a Developing item on the NCWM agenda.

Additional letters, presentations, and data may have been part of the Committee's consideration. To review the supporting documentation, please refer to the *Report of the 98th National Conference on Weights and Measures* (SP 1171, 2013).

Mr. Raymond Johnson, New Mexico | Committee Chair
Mr. Tim Lloyd, Montana | Member
Mr. Richard Lewis, Georgia | Member
Mr. Louis Sakin, Towns of Hopkinton/Northbridge, Massachusetts | Member
Mr. John Albert, Missouri | Member

Mr. Steven Grabski, Wal-Mart Stores | Associate Membership Representative
Mr. Lance Robertson, Measurement Canada | Canadian Technical Advisor
Mr. David Sefcik, NIST, OWM | NIST Technical Advisor
Ms. Lisa Warfield, NIST, OWM | NIST Technical Advisor

Laws and Regulations Committee

THIS PAGE INTENTIONALLY LEFT BLANK

Appendix A Handbook 130

Uniform Method of Sale and Uniform Engine Fuels and Automotive Lubricants Regulation

Items:

232-2, 232-3, 237-1, 237-2, 237-3, and 237-5: Background and Justification for Handbook 130 Definition of “Diesel Gallon Equivalent (DGE)” of Natural Gas as a Vehicular Fuel

Clean Vehicle Education Foundation

Development of the “Gasoline Gallon Equivalent” by NCWM*

In 1993, under the auspices of the National Conference on Weights and Measures (NCWM), a Compressed Natural Gas (CNG) Working Group came together to determine the way in which CNG would be sold to the public at retail as a motor fuel.

The working group focused on three issues:

1. How to provide the Natural Gas Vehicle (NGV) industry a method of sale that would be familiar and acceptable to consumers
2. How to provide weights and measures officials a verifiable and quantifiable means to determine the accuracy of natural gas dispensers; and
3. How to meet these requirements with a uniform, national standard.

NCWM considered three proposals for the method of sale of CNG:

1. joules, the unit of energy measurement in SI units
2. mass
3. the Gasoline Gallon Equivalent (GGE)

The Natural Gas Vehicle Coalition (now NGV America) recommended that the Gasoline Gallon Equivalent be adopted as the method of sale for CNG, and that it be based on the energy equivalent of a gallon of gasoline. The use of the GGE was recommended primarily for the convenience of the retail customer comparing the cost and fuel economy of a natural gas vehicle to a comparable gasoline vehicle. During the discussion, a proposal was made to eliminate the reference to energy content of CNG and replace it with a fixed conversion factor based on mass, with the fixed mass of CNG

* *Report of the 78th National Conference on Weights and Measures, 1993*, NIST Special Publication 854, pp 322-326.

Report of the 79th National Conference on Weights and Measures, 1994, NIST Special Publication 870, pp 213-217.

Program and Committee Reports for the National Conference on Weights and Measures, 79th Annual Meeting, July 17 - 21, 1994, NCWM Publication 16, pp 89-92.

being equal to a gallon of gasoline. Measurement of mass in the retail dispenser and verification by W&M officials is easier and less costly than measurement of energy content.

Since the energy content of a unit measure of CNG (standard cubic foot - scf) and gasoline (gallon) vary widely depending on the sample of fuel measured, the reference gallon of gasoline was determined to be Indolene, the gasoline used by EPA to certify emissions and fuel economy, with an energy content (lower heating value) of 114,118 BTU/gal. Work conducted by the Institute of Gas Technology and the Gas Research Institute (now combined into the Gas Technology Institute) surveyed 6811 samples of natural gas nationwide and concluded that the “average” natural gas in the US had an energy content (lower heating value) of 923.7 BTU/scf, and a density of 0.0458172 lbs/cubic foot. This translates 20,160.551 BTU/lb. Dividing gasoline’s 114.118 BTU/gal by natural gas’s 20,160.551 BTU/lb gives 5.660 lbs of natural gas = 1 GGE. Similar calculations determined that a gasoline liter equivalent of natural gas equals 0.678 kg of natural gas.

At its 79th annual meeting in July of 1994, NCWM adopted resolutions that:

“All natural gas kept, offered or exposed for sale or sold at retail as a vehicle fuel shall be in terms of the gasoline liter equivalent (GLE) or gasoline gallon equivalent (GGE), and

All retail natural gas dispensers shall be labeled with the conversion factor in terms of kilograms or pounds. The label shall be permanently and conspicuously displayed on the face of the dispenser and shall have either the statement “1 Gasoline Liter Equivalent (GLE) is equal to 0.678 kg of Natural Gas” or “1 Gasoline Gallon Equivalent (GGE) is equal to 5.660 lbs of Natural Gas” according to the method of sale used.”

These statements can be found in NIST Handbook 130*, along with the definition of “natural gas” which seems to apply only to Compressed Natural Gas, not to Liquefied Natural Gas. Handbook 130, §§3.11 and 3.12 (Engine Fuels, Petroleum Products, and Automotive Lubricants Regulations) confirm that these requirements are for CNG, rather than LNG. Similar requirements and definitions are found in Handbook 44.

During the discussions it was recognized that, although diesel and gasoline are both sold in gallon units, a gallon of diesel fuel has substantially more energy content than a gallon of gasoline. While it is convenient to use the Gasoline Gallon Equivalent unit when comparing the cost and fuel economy of gasoline-powered light-duty vehicles to equivalent natural gas vehicles, a Diesel Gallon Equivalent unit would be more useful for operators of medium and heavy-duty (usually diesel powered) vehicles. However, in 1994, the NCWM working group “agreed to defer development of a “Diesel Gallon Equivalent” until the issues related to the ‘Gasoline Gallon Equivalent’ were decided by

* “Method of Sale Regulation,” §2.27.

the NCWM and agreed to meet again if additional work is necessary.”** The issue of the formal definition a Diesel Gallon Equivalent (DGE) unit has not come before NCWM from that time until today, although the DGE is often used in the industry, defined as 6.31 lbs of natural gas.

Need for a Definition of a “Diesel Gallon Equivalent” Unit

Today there are an increasing number of commercial vehicles using natural gas as a fuel, to lower emissions and Greenhouse Gases, decrease America’s use of petroleum, and lower fuel costs (U.S. DOE Clean Cities Alternative Fuel Price Report for April 2012 shows in Table 2 ‘Overall Average Fuel Price on Energy-Equivalent Basis’ that diesel is priced at \$4.12/gal and CNG at \$2.32/gal (http://www.afdc.energy.gov/afdc/pdfs/afpr_apr_12.pdf).

Since the NCWM’s working group deferred development of a DGE unit in 1994, there has been little call by the natural gas vehicle industry for the formalization of that unit in the sale of **Compressed** Natural Gas. However the use of **Liquefied** Natural Gas (LNG) as a motor fuel has been growing and there is significant interest in using the DGE as a unit for the sale of that fuel.

LNG as a motor fuel is used almost exclusively by commercial vehicles, most of which view diesel as the conventional alternative. Using the same logic as was used for the development of the GGE unit, the convenience of the retail customer comparing the cost and fuel economy of a natural gas vehicle to a comparable conventional vehicle, it makes sense for NCWM to now “officially” define the DGE.

Other than §3.12. Liquefied Natural Gas, in the Engine Fuels and Automotive Lubricants Regulation section of Handbook 130, we find no specific provisions in either Handbook 44 or Handbook 130 for the retail sale of LNG as a motor fuel. However LNG is sold in California and other states on a mass basis (by the pound), which allows for easy confirmation by weights and measures authorities. An “official” definition of the DGE as a specific mass of natural gas would allow states to easily move from retail sale by pound to retail sale by DGE, simplifying the sale process for the retail customer used to dealing with “gallons of diesel” as a fuel measure.

Therefore, at this time we are asking for a definition of the Diesel Gallon Equivalent (and Diesel Liter Equivalent) units by NCWM.

Justification of the Definition of a DGE as 6.312 Pounds of Natural Gas

Handbook 130 contains the following definitions of natural Gas as a vehicle fuel*:

Gasoline liter equivalent (GLE). – Gasoline liter equivalent (GLE) means

** *Report of the 79th National Conference on Weights and Measures, 1994*, NIST Special Publication 870, p 214

* NIST handbook 130, 2006, Method of State Regulation, §§2.27.1.2. and 2.227.1.3.; also Engine Fuels, Petroleum Products, and Automotive Lubricants Regulation, §§1.25. and 1.26.

0.678 kg of natural gas.

Gasoline gallon equivalent (GGE). – Gasoline gallon equivalent (GGE) means 2.567 kg (5.660 lb) of natural gas.

As the NCWM working group recognized during its deliberations in 1993 on the Gasoline Gallon Equivalent unit, both gasoline and natural gas can vary in their BTU content from sample to sample. The working group determined the gasoline gallon (energy) equivalent based on a gallon of Indolene (114,118 BTU/gal – lower heating value) and a survey of 6811 natural gas samples nationwide with an average of 923.7 BTU/scf (lower heating value) and a density of 0.0458172 lbs/cubic foot. This equates to 20,160.551 BTU/lb. Dividing gasoline's 114.118 BTU/gal by natural gas's 20,160.551 BTU/lb gives 5.660 lbs of natural gas = 1 GGE. Similar calculations determined that a gasoline liter equivalent of natural gas equals 0.678 kg of natural gas.

Starting with 5.660 lbs of natural gas = 1 GGE and 0.678 kg of natural gas = 1 GLE, we can calculate the mass of natural gas necessary to make a DGE and a DLE by comparing the amount of energy in a gallon of diesel fuel to the amount of energy in a gallon of gasoline fuel and apply that ratio to scale up the masses of natural gas calculated for the GGE and GLE units.

Unfortunately it is no easier today than it was in 1993 to set one energy value as representative of a unit for all gasoline, (or diesel) fuel. EPA's certification fuel has likely changed in energy content since 1993, as both gasoline and diesel fuels have been modified for improved emissions.

We recommend using the most recent Department of Energy *Transportation Energy Data Book*^{*}, as an authoritative reference for both gasoline and diesel fuel energy values. Taking further surveys or basing our calculations on today's EPA certification fuel only delays our action, substantially increases costs, and, in the end, provides a limited potential increase in accuracy based on one point in time. Table B.4 of the *Transportation Energy Data Book*, on the heat content of fuels http://cta.ornl.gov/data/tedb30/Edition30_Full_Doc.pdf lists the net energy of gasoline as 115,400 BTU/Gal, and diesel as 128,700 BTU/Gal.

Therefore a Diesel Gallon Equivalent of natural gas is:

$$(128,700/115,400) \times 5.660 = 6.312 \text{ lb (2.863 kg)}$$

and a Diesel Liter Equivalent of natural gas is:

$$(128,700/115,400 \times 0.678 = 0.756 \text{ kg}$$

Prepared by:

Clean Vehicle Education Foundation

<http://www.cleanvehicle.org>

^{*} Stacy C. Davis and Susan W. Diegel, Oak Ridge National Laboratory, *Transportation Energy Data Book*, Edition 30, 2011, ORNL-6978, or <http://cta.ornl.gov/data/index.shtml>

Appendix B
NIST Handbook 133

Section 3. Test Procedures – Packages Labeled by Volume

Item:

260-2: Section 3.12. Fresh Oysters Labeled by Volume

NIST Office of Weights and Measures

Table of Contents

Item	L&R – B Page
Worksheet for Determining the Free Liquid and Net Volume of Oysters	3
Worksheet for Determining the Free Liquid and Net Volume of Oysters – Sample	4
Drawings for an Oyster Strainer and Drain Pan	5

THIS PAGE INTENTIONALLY LEFT BLANK

Date:	Worksheet for Determining the Free Liquid and Net Volume of Oysters								Report Number:	
Location (name, address):			Product/Brand Identity:			Manufacturer:			Container Description:	
			Lot Codes:							
1. Labeled Quantity:	2. Unit of Measure:	3. Inspection Lot Size:				4. Sample Size:				
Amount of Free Liquid Values										
Steps:	Pkg 1	Pkg 2	Pkg 3	Pkg 4	Pkg 5	Pkg 6	Pkg 7	Pkg 8	Pkg 9	Pkg 10
1. Weight of Dry Receiving Pan										
2. Gross Weight of Package										
Reference Temperature of Oysters 7 °C (± 1) [45 °F (± 2)]										
3. Tare Weight of Package										
4. Net Weight of Oysters & Liquid (Step 2 – Step 3 =)										
5. Weight of Receiving Pan and Drained Liquid										
6. Weight of Free Liquid (Step 5 – Step 1 =)										
7. Percentage (%) of Free Liquid (Step 6 ÷ Step 4 × 100 =)										
Net Volume										
1. Test the oysters at the temperature of 7 °C (± 1) [45 °F (± 2)]. 2. Establish the level of fill of the package using a depth gage. 3. Empty and dry the package. 4. Refill the package with water to the level of the depth gage. 5. Record the amount of delivered water and then sum the quantities to obtain the total volume in the package.										
	Quantity of Water Delivered into Package									
	Pkg 1	Pkg 2	Pkg 3	Pkg 4	Pkg 5	Pkg 6	Pkg 7	Pkg 8	Pkg 9	Pkg 10
8. Flask Size										
9. Flask Size										
10. Graduate or Cylinder										
11. Graduate or Cylinder										
12. Total (8 + 9 + 10 =)										
Comments:										

L&R Committee 2014 Final Report
 Appendix B – NIST Handbook 133, Item 260-2: Section 3.12. Fresh Oysters

Date: December 20, 2013	Worksheet for Determining the Free Liquid and Net Volume of Oysters								Report Number: 1 of 2	
Location (name, address): Superchain Market Main Street Bradenton, FL	Product/Brand Identity: World's Best Oysters – Oyster Standard				Manufacturer: World's Best Packing Beach Road, AL			Container Description: Clear Plastic Tub with metal pull top		
	Lot Codes: 12/26/2012									
1. Labeled Quantity: 12 fl. oz. (355 ml)	2. Unit of Measure: 0.001 lb	3. Inspection Lot Size: 206			4. Sample Size: 12					
Amount of Free Liquid Values										
Steps:	Pkg 1	Pkg 2	Pkg 3	Pkg 4	Pkg 5	Pkg 6	Pkg 7	Pkg 8	Pkg 9	Pkg 10
1. Weight of Dry Receiving Pan	11.841	11.841	11.841	11.841	11.841					
2. Gross Weight of Package	0.871	0.884	0.920	0.869	0.8632					
Reference Temperature of Oysters 7 °C (± 1) [45 °F (± 2)]	44 °F	46 °F	44 °F	47 °F	45.5 °F					
3. Tare Weight of Package	0.060	0.060	0.060	0.059	0.060					
4. Net Weight of Oysters & Liquid (Step 2 – Step 3 =)	0.811	0.824	0.86	0.81	0.803					
5. Weight of Receiving Pan and Drained Liquid	12.020	12.121	12.120	12.031	12.242					
6. Weight of Free Liquid (Step 5 – Step 1 =)	0.179	0.28	0.279	0.19	0.401					
7. Percentage (%) of Free Liquid (Step 6 ÷ Step 4 × 100 =)	22 %	33 %	32 %	23 %	49 %					
Net Volume										
1. Test the oysters at the temperature of 7 °C (± 1) [45 °F (± 2)]. 2. Establish the level of fill of the package using a depth gage. 3. Empty and dry the package. 4. Refill the package with water to the level of the depth gage. 5. Record the amount of delivered water and then sum the quantities to obtain the total volume in the package.										
	Quantity of Water Delivered into Package									
	Pkg 1	Pkg 2	Pkg 3	Pkg 4	Pkg 5	Pkg 6	Pkg 7	Pkg 8	Pkg 9	Pkg 10
8. Flask Size										
9. Flask Size										
10. Graduate or Cylinder										
11. Graduate or Cylinder										
12. Total (8 + 9 + 10 =)										
Comments:										

Issued: May 17, 2013

Drawings for an Oyster Strainer and Drain Pan

This design of strainer is required in AOAC International 35.1.07 (953.11) for use in determining the drained liquid from shucked oysters. The specifications for the diameter of the perforations and their spacing were adopted by the AOAC in 1955.

THESE DRAWINGS ARE NOT TO SCALE

This document based on a drawing (No. 1847 - August 1997) provided by the North Carolina Department of Agriculture, Division of Standards & Division of Marketing's Engineering Program.

AOAC Description

- **Apparatus:**
 - Strainer (skimmer): flat metal pan with 50.8 mm (2 inches) sides.
 - Area: 1,900 square centimeters (300 square inches) for each 3.785 L (1 gallon) of oysters to be poured onto the pan. A smaller strainer and pan may be constructed for testing package sizes less than 3.785 L (1 gallon).
 - Perforations and Spacing: 6 mm (1/4 inch) diameter and spaced in a 32 mm (1-1/4 inches) square pattern.
- **Use: Quickly distribute oysters evenly over draining surface with minimum of handling.**
 - Drain Time: 2 minutes.
 - Temperature: 7 °C (± 1 °C) 45 °F (± 2 °F)

General Notes

- Construct with 12 gage stainless steel (recommended but lighter or heavier gages are permitted). For ease of handling the weight should be kept to a minimum.
- The strainer and pan may be one-piece boxes with bent and welded sides or constructed entirely of plate.
- Containers will be used to weigh and measure food products so all welds must be watertight for ease of cleaning and to prevent the accumulation of water that may promote bacteria growth.
- Grind, smooth and polish all joints, and perforations.

THIS DRAWING NOT TO SCALE

Typical Layout of Perforations

Perforation
Diameter: 6 mm
(1/4 inch).

Spacing: a 32 mm
(1-1/4 inches)
square pattern as
show in the detail
to left.

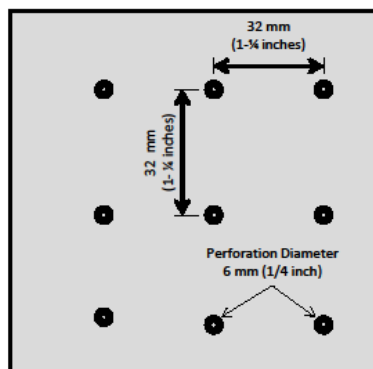

Locate Hole Grid on
Center Line (C_L) of
strainer (see next page).
For a strainer with given
dimensions there will be
13 holes per row and 13
rows. For strainers of
other dimensions the
number of holes per row
and number of rows will
vary.

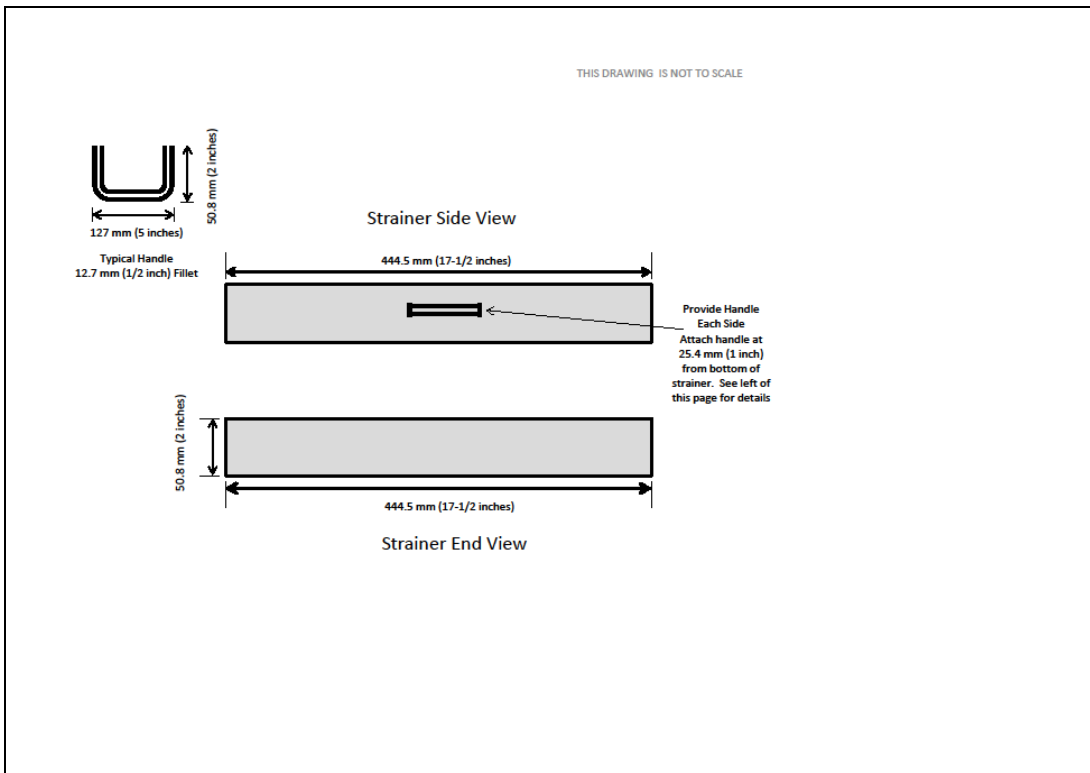
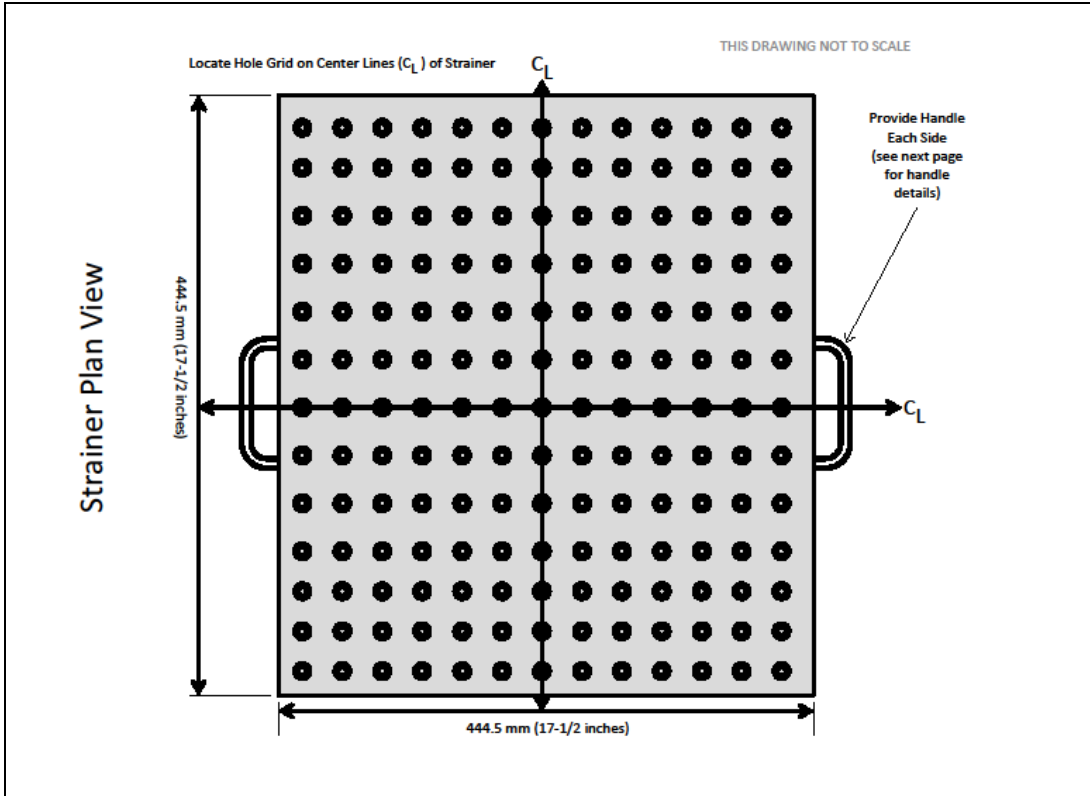

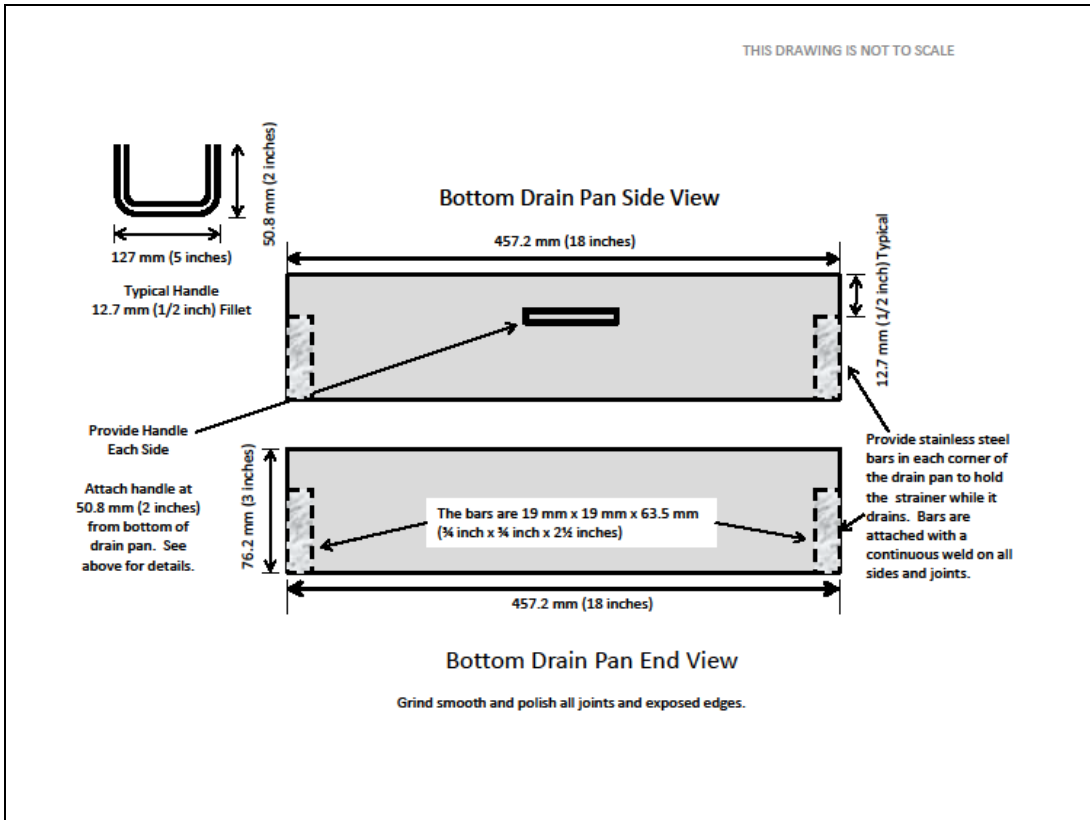
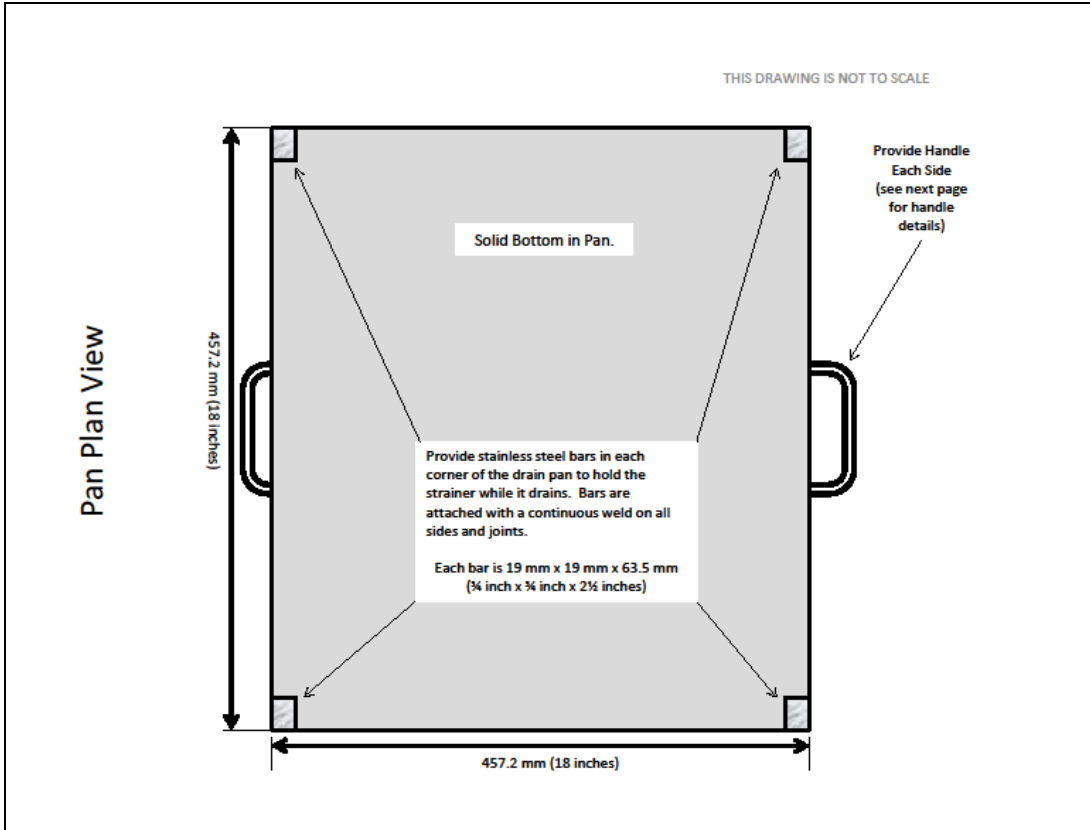

Appendix C NIST Handbook 130

Uniform Regulation for the Method of Sale

Items:

- 232-6: 2.30. ~~E85 Fuel~~ Ethanol Flex Fuel Blends and
- 237-9: Section 1. Definitions, Section 2. Standard Fuel Specifications, and Section 3. Classification and Method of Sale of Petroleum Items

Table of Contents

Item	Page L&R – C
Letter from FALS to the Federal Trade Commission (June 13, 2014)	3

THIS PAGE INTENTIONALLY LEFT BLANK



National Conference on Weights and Measures
"That Equity May Prevail"

June 13, 2014

Federal Trade Commission
Office of the Secretary
Room H-113 (Annex N)
600 Pennsylvania Ave, NW
Washington, DC 20580

RE: Fuel Rating Rule Review, 16 CFR Part 306, Project No. R811005

Dear Sir or Madam;

Comments to this notice of proposed rulemaking are being provided on behalf of the Fuels and Lubricants Subcommittee (FALS) within the Laws and Regulations Committee (L&R) as part of the National Conference on Weights and Measures (NCWM). We would like to start by thanking the FTC for the opportunity to provide comments on these important proposed rules. As we will elaborate in the following paragraphs, FALS encourages the FTC to adopt by reference the labeling language in the National Institute of Standards and Technology (NIST) Handbook 130, Uniform Regulation for the Method of Sale of Commodities, Section 2.30, and Uniform Engine Fuels and Automotive Lubricants Regulations, Section 3.8. If adoption by reference is not possible under FTC guidelines, FALS then encourages the FTC to adopt the aforementioned sections of NIST Handbook 130, specifying the 2015 Edition, which will be published in January 2015. Additionally, FALS requests the FTC to extend the comment period until July 31, 2014, in order to allow the 2014 Annual Meeting of the National Conference on Weights and Measures to conclude and determine the final language that will be adopted in the 2015 Edition of NIST Handbook 130 as it may change from the current proposed language. Should it not be possible to extend the comment period until after the NCWM's Annual Meeting in July, FALS would still be happy to provide the final language that will be adopted in NIST Handbook 130 to the FTC after the conclusion of the meeting.

Introduction

FALS was formed within the NCWM to provide a specialized and focused body dedicated to fuel related issues that aids the L&R Committee when discussing, evaluating and recommending next steps for fuel related agenda items. The membership consists of a broad base of stakeholders comprised of subject matter experts from state regulatory agencies; oil, automotive, and ethanol companies; and fuel wholesalers, distributors, and retailers. It should be noted that FALS position presented in this letter does not represent the position of the automakers represented on FALS. They intend to submit a separate statement detailing their position. A complete list of current FALS members may be found on the NCWM website at the link below.

<http://www.ncwm.net/committees/laws-regulations/subcommittee/fals>

1135 M Street, Suite 110 | Lincoln, Nebraska 68508
P. 402.434.4880 F. 402.434.4878 W. www.ncwm.net

FALS members routinely deliberate and discuss fuel related topics on local, regional and national platforms and specifically, have spent many hours deliberating and discussing the issues contained in this FTC proposal. Further, FALS has spent a considerable amount of time developing analogous proposed modifications to NIST Handbook 130, Uniform Regulation for the Method of Sale of Commodities and Uniform Engine Fuels and Automotive Lubricants Regulations. These proposals can be found in the 2014 Edition of NCWM Publication 16, L&R agenda items 232-6 and 237. A copy of the proposed language is attached to this letter and printed copies of the final language will be available later this summer after the conclusion of the July meeting.

Background

There has been considerable recent interest in expanding the market for Flex-Fuel Vehicles (FFVs) and the fuels suitable for use in these vehicles. Several technical and regulatory issues were identified within the NCWM and ASTM International (ASTM) as impediments or necessary improvements needed for the evolution and expansion of these fuels. Two major actions were recently taken at ASTM in this regard and analogous steps are also in progress at the NCWM, through FALS.

ASTM International

During recent ASTM meetings, two technical issues with regard to the formerly known product 'E85' were identified.

1. The hydrocarbons necessary to blend ASTM D5798, "Specification for Ethanol Fuel Blends for Flexible-Fuel Automotive Spark-Ignition Engines" compliant fuels, were not readily available.
2. The version of ASTM D5798 that had been in effect for many years recognized three volatility classes for these fuels and applied them throughout the entire country. By contrast the specifications for conventional spark-ignition engine fuels as detailed in ASTM D4814 have six different volatility classes, thus better acknowledging the affects of climate on volatility. As a result, ASTM D5798 was in need of a revision to better address this issue. Investigations began with a test project conducted under the guidance of the Coordinating Research Council (CRC) within ASTM to evaluate the volatility needs of modern FFVs. These studies evaluated the concentration(s) of ethanol required when blending with more readily available hydrocarbon sources to meet the volatility requirements necessary for proper vehicle operation. Stakeholder consensus was reached and ASTM D5798 was modified, thus increasing the number of volatility classes from three to four and expanding the range of permissible ethanol concentration from a minimum 68 volume percent down to a new minimum of 51 volume percent. The maximum concentration of 83 volume percent remained unchanged. The lower ethanol limit allows gasoline and gasoline blendstocks readily available at fuel terminals to be used when blending ASTM D5798 compliant fuels.

It should be noted that similar fuels can also be blended on-site at retail dispensers (through blender pumps) at some locations, but this technique is not addressed in the two aforementioned ASTM Designations. However, a broad stakeholder group began working to develop an ASTM standard for this blending technique. Out of that work was borne ASTM D7794, "Standard Practice for Blending Mid-Level Ethanol Fuel Blends for Flexible-Fuel Vehicles with Automotive Spark-Ignition Engines", which addresses fuels with ethanol concentrations restricted to FFVs, but less than 51 volume percent.

Both standards were developed and revised over several years with input from a very broad base of specialized stakeholders and subject matter experts and consensus was achieved within the ASTM process.

NCWM

The National Conference on Weights and Measures is a professional nonprofit association of state and local weights and measures officials, federal agencies, manufacturers, retailers and consumers dedicated to developing weights and measures standards since 1905. The National Institute of Standards and Technology (NIST) publishes the uniform laws, regulations and standards developed by the NCWM and incorporates them in NIST Handbook 130, which is used and adopted by numerous states. The NCWM focuses on creating new standards to accommodate innovation and to promote uniformity in the marketplace.

At the NCWM Annual Meeting in July 2010 a task force was formed under FALS to review the wording in NIST Handbook 130 and recommend modifications to FALS that were necessary to address the full range of ethanol concentrations allowed in FFV fuels. It was acknowledged at that time that the full range of ethanol concentrations available in these fuels was not currently addressed in the Uniform Engine Fuels and Automotive Lubricants Regulation or Uniform Regulation for the Method of Sale of Commodities Sections in NIST Handbook 130. The task group immediately sought input not only from the member fuel experts, but also from stakeholder fuel experts outside of FALS and even outside of the NCWM. All input received was discussed within the task force and the task force proceeded to develop initial proposed modifications to NIST Handbook 130 presenting its recommendations to FALS for review and approval. FALS continued to review the proposed modifications within the subcommittee and made several modifications, ultimately reaching consensus of the subcommittee. The final proposed modifications were presented at the NCWM regional meetings and then again to the L&R Committee at the NCWM Interim Meeting in January 2014. The L&R Committee then recommended designating two agenda items on this topic as 'voting' for the NCWM Annual Meeting in July 2014. These are L&R agenda items 232-6 and 237-9, as referenced above. Should these items carry consensus in July 2014, they will become part of the 2015 Edition of NIST Handbook 130 and become part of the regulations adopted by numerous states.

Summary

Both the ASTM and NCWM processes invite and involve a broad base of diverse stakeholders working to develop consensus positions for the market and industry. These subject matter expert stakeholders have openly discussed the multitude of technical and regulatory issues related to these topics. However, a number of the positions which gained consensus through the extensive ASTM and NCWM processes are not in concert with the current proposed regulations contained in the 2014 FTC NPRM. Key differences between the 2014 NPRM and the current proposals to update NIST Handbook 130 are listed below.

1. FALS supports the FTC's intent to prevent vehicle misfueling. However, FALS does not believe the proposed FTC language adequately provides consumers with sufficient information to prevent misfueling to the greatest extent possible. Specifically, the term "Flex Fuel" applies to higher concentration ethanol blended products (e.g. greater than 15 percent ethanol, by volume), but does not include other alcohol blends such as M85 and butanol-blended fuels (both of which are viable fuels and have specifications detailed in different ASTM Designations). Without the use of "Ethanol" in conjunction with "Flex-Fuel" consumers may incorrectly assume that M85 and/or butanol-blended fuels are also suitable for use in their FFVs.
 - a. FALS recommends the FTC adopt the labeling requirements as proposed in L&R agenda items 232-6 and 237-9, requiring the word "Ethanol" to be used in conjunction with the term "Flex-Fuel", thus introducing the term "Ethanol Flex-Fuel Blend." Please see the attachment for the recommended language in full.

2. FALS supports the FTC's intent to identify the level of ethanol in blended fuels. However, FALS does not believe the proposed FTC language allows for all viable options. This issue received much discussion at ASTM meetings and particularly the NCWM meetings, both with the intent to minimize required labeling changes while at the same time providing the public with sufficient information regarding the composition of the fuel being purchased. Specifically, FALS recommends the FTC adopt the labeling requirements as proposed in L&R agenda items 232-6 and 237-9, and described below. Please see the attachment for the recommended language in full.
 - a. Ethanol blends containing 51 percent ethanol, by volume, or more (up to 83 percent ethanol, by volume) should be labeled as "Ethanol Flex Fuel, minimum 51% ethanol."
 - b. Ethanol blends containing less than or equal to 50 percent, by volume, shall be labeled as "EXX Flex Fuel, minimum YY% ethanol", where the XX is the target ethanol concentration in volume percent and YY is XX minus 5. The actual ethanol concentration of the blend shall be XX volume percent plus or minus 5 volume percent.
 - c. Existing requirements in NIST Handbook 130 require such fuel labels to also contain the wording "For Use in Flexible Fuel Vehicles (FFV) Only" and L&R Agenda items 232-6 and 237-9 also propose to add "CHECK OWNER'S MANUAL" to this language as proper guidance for consumers to ensure they have verified this fuel is suitable for use in their vehicle.
3. FALS and its members feel it is extremely important to rely on broad based consensus standards as much as possible, which is the goal of ASTM International and the National Conference on Weights and Measures. FALS also believes this is equally as important to the FTC. The NCWM proposals rely on the most recent versions of the referenced ASTM Designations, thus automatically incorporating changes in the NIST Handbooks. Specifying discrete versions impedes the ability of industry to advance in accordance with changes to its own marketplace.
 - a. FALS recommends the FTC not adopt specific versions of ASTM Designations rather adopt language analogous to "the most recent version of DXXXX", where applicable. However, recognizing not all regulatory entities are permitted to use this approach, in the least FALS recommends the FTC include the most recent version number published at the last possible date during rule promulgation.

Conclusion

To summarize, FALS encourages the FTC to adopt by reference the labeling language in the National Institute of Standards and Technology (NIST) Handbook 130, Uniform Regulation for the Method of Sale of Commodities, Section 2.30, and Uniform Engine Fuels and Automotive Lubricants Regulations, Section 3.8. If adoption by reference is not possible under FTC guidelines, FALS then encourages the FTC to adopt the aforementioned sections of NIST Handbook 130, specifying the 2015 Edition, which will be published in January 2015. Additionally, FALS requests the FTC to extend the comment period until July 31, 2014, in order to allow the 2014 Annual Meeting of the National Conference on Weights and Measures to conclude and determine the final language that will be adopted in the 2015 Edition of NIST Handbook 130 as it may change from the current proposed language. Should it not be possible to extend the comment period until after the NCWM's Annual Meeting in July, FALS would still be happy to provide the final language that will be adopted in NIST Handbook 130 to the FTC after the conclusion of the meeting.

FALS again thanks the FTC for this opportunity to provide comments regarding these important proposed rules and is ready and willing to discuss further, if desired. We may be reached at (850) 921-1570 or at Matthew.Curran@FreshFromFlorida.com.

Regards,



Dr. Matthew D. Curran, Chairman
NCWM Fuels and Lubricants Subcommittee

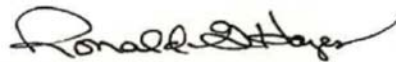

Mr. Ronald Hayes, Vice-Chairman
NCWM Fuels and Lubricants Subcommittee



Mr. Randy Jennings, Vice-Chairman
NCWM Fuels and Lubricants Subcommittee

Attachment

Proposed language for the National Institute of Standards and Technology (NIST) Handbook 130, Uniform Regulation for the Method of Sale of Commodities, Section 2.30, and Uniform Engine Fuels and Automotive Lubricants Regulations, Section 3.8, L&R agenda items 232-6 and 237-9, respectively.

Ethanol Flex Fuel Blends.

1. How to Identify Ethanol Flex Fuel Blends. – Ethanol flex fuel blends shall be identified as ethanol flex fuel or EXX flex fuel.

2. Labeling Requirements

(a) Fuel ethanol flex fuel blends with an ethanol concentration no less than 51 and no greater than 83 volume percent shall be labeled "Ethanol Flex Fuel, minimum 51 % ethanol".

(b) Ethanol Flex Fuel blends with an ethanol concentration less than or equal to 50 volume percent shall be labeled "EXX Flex Fuel, minimum YY % ethanol", where the XX is the target ethanol concentration in volume percent and YY is XX minus 5. The actual ethanol concentration of the blend shall be XX volume percent plus or minus 5 volume percent.

(c) A label shall be posted which states "For Use in Flexible Fuel Vehicles (FFV) Only." This information shall be clearly and conspicuously posed on the upper 50 % of the dispenser front panel in a type at least 12.7 mm (½ in) in height, 1.5 mm (1/16 in) stroke (width of type). A label shall be posted which states, "CHECK OWNER'S MANUAL," and shall not be less than 6 mm (¼ in) in height by 0.8 mm (1/32 in) stroke; block style letters and the color shall be in definite contrast to the background color to which it is applied.

Report of the Specifications and Tolerances (S&T) Committee

Mr. Brett Gurney, Committee Chair
Utah

Reference
Key Number

300 INTRODUCTION

This is the final report of the Committee on Specifications and Tolerances (S&T) (hereinafter referred to as the “Committee”) for the 99th Annual Meeting of the National Conference on Weights and Measures (NCWM). This report is based on the Interim Report offered in the NCWM Publication 16, “Committee Reports,” testimony at public hearings, comments received from the regional weights and measures associations and other parties, the NCWM 2014 Online Position Forum, the addendum sheets issued at the Annual Meeting, and actions taken by the membership at the voting session of the Annual Meeting. The Informational items shown below were adopted as presented when this report was approved. This report contains those recommendations to amend National Institute of Standards and Technology (NIST) Handbook 44 (2014), “Specifications, Tolerances, and Other Technical Requirements for Weighing and Measuring Devices.”

Table A identifies the agenda items and appendix items. The agenda items in the Report are identified by Reference Key Number, title, page number and the appendices by appendix designations. The acronyms for organizations and technical terms used throughout the agenda are identified in Table C. The first three digits of the Reference Key Numbers of the items are assigned from The Subject Series List. The status of each item contained in the report is designated as one of the following: **(D) Developing Item:** the Committee determined the item has merit; however, the item was returned to the submitter or other designated party for further development before any action can be taken at the national level; **Informational (I) Item:** the item is under consideration by the Committee but not proposed for Voting; **(V) Voting Item:** the Committee is making recommendations requiring a vote by the active members of NCWM; **(W) Withdrawn Item:** the item has been removed from consideration by the Committee.

Table B provides a summary of the results of the voting on the Committee’s items and the report in its entirety. Some Voting Items are considered individually, others may be grouped in a consent calendar. Consent calendar items are Voting Items that the Committee has assembled as a single Voting Item during their deliberation after the Open Hearings on the assumption that the items are without opposition and will not require discussion. The Voting Items that have been grouped into consent calendar items will be listed on the addendum sheets. Prior to adoption of the consent calendar, the Committee entertains any requests from the floor to remove specific items from the consent calendar to be discussed and voted upon individually.

Proposed revisions to the handbook(s) are shown as follows: 1) deleted language is indicated with a **bold face font using strikeouts** (e.g., ~~this report~~), 2) proposed new language is indicated with an **underscored bold faced font** (e.g., new items), and 3) nonretroactive items are identified in *italics*. When used in this report, the term “weight” means “mass.”

Note: The policy of NIST and NCWM is to use metric units of measurement in all of their publications; however, recommendations received by NCWM technical committees and regional weights and measures associations have been printed in this publication as submitted. Therefore, the report may contain references to inch-pound units.

Subject Series List

Introduction	300 Series
NIST Handbook 44 – General Code	310 Series
Scales	320 Series
Belt-Conveyor Scale Systems	321 Series
Automatic Bulk Weighing Systems	322 Series
Weights	323 Series
Automatic Weighing Systems	324 Series
Liquid-Measuring Devices	330 Series
Vehicle-Tank Meters	331 Series
Liquefied Petroleum Gas and Anhydrous Ammonia Liquid-Measuring Devices	332 Series
Hydrocarbon Gas Vapor-Measuring Devices	333 Series
Cryogenic Liquid-Measuring Devices	334 Series
Milk Meters	335 Series
Water Meters	336 Series
Mass Flow Meters	337 Series
Carbon Dioxide Liquid-Measuring Devices	338 Series
Hydrogen Gas-Metering Devices – Tentative Code	339 Series
Vehicle Tanks Used as Measures	340 Series
Liquid Measures	341 Series
Farm Milk Tanks	342 Series
Measure-Containers	343 Series
Graduates	344 Series
Dry Measures	345 Series
Berry Baskets and Boxes	346 Series
Fabric-Measuring Devices	350 Series
Wire-and Cordage-Measuring Devices	351 Series
Linear Measures	352 Series
Odometers	353 Series
Taximeters	354 Series
Timing Devices	355 Series
Grain Moisture Meters	356 Series
Near-Infrared Grain Analyzers	357 Series
Multiple Dimension Measuring Devices	358 Series
Electronic Livestock, Meat, and Poultry Evaluation Systems and/or Devices – Tentative Code	359 Series
Other Items – Developing Items	360 Series

Table A
Table of Contents

Reference Key	Title of Item	Page S&T
300	INTRODUCTION	1
310	HANDBOOK 44 - GENERAL CODE	7
310-1	D G-S.1. Identification. – (Software).....	7
310-2	VC G-S.5.6. Recorded Representations	12
320	SCALES.....	15
320-1	W S.2.1.6. Combined Zero-Tare (“0/T”) Key	15
320-2	VC UR.2.4. Foundations, Supports, and Clearance	17
320-3	I Part 2.20. Weigh-In-Motion Vehicle Scales for Law Enforcement – Work Group	20
321	BELT-CONVEYOR SCALE SYSTEMS	23
321-1	VC UR.1.2. Conveyor Installation	23
330	LIQUID MEASURING DEVICES	25
330-1	VC S.1.6.7. and S.1.6.8. Recorded Representations and UR.3.3. Computing Device	25
330-2	W S.1.6.7. Recorded Representations.....	28
330-3	VC N.4.2.4. Wholesale Devices	29
330-4	D N.4.2.5. Initial Verification and UR.2.5.1. Initial Verification Proving Reports	32
330-5A	VC UR.3.3. Computing Device.....	35
330-5B	VC UR.3.3. Computing Device.....	39
330-6	W UR.4. Maintenance Requirements	40
330-7	D Part 3.30. Price Posting and Computing Capability and Requirements for a Retail Motor-Fuel Dispenser (RMFD)	42
331	VEHICLE-TANK METERS	44
331-1	D N.4.6. Initial Verification and UR.1.5. Initial Verification Proving Reports	44
331-2	W UR.3. Maintenance Requirements	46
332	LPG AND ANHYDROUS AMMONIA LIQUID-MEASURING DEVICES.....	48
332-1	D S.1.4.3. Provisions for Power Loss, S.1.5.1.1. Unit Price, S.1.5.1.2. Product Identity, S.1.6. For Retail Motor Vehicle Fuel Devices Only, S.1.7. For Wholesale Devices Only, UR.2.7. Unit Price and Product Identity, and UR.2.8 Computing Device.....	48
332-2	VC S.1.5.3. Recorded Representations, Point-of-Sale Systems	54
336	WATER METERS	55
336-1	W UR.3. Installation Requirements.....	55
337	MASS FLOW METERS	57
337-1	W Appendix D – Definitions: Diesel Liter Equivalent (DLE) and Diesel Gallon Equivalents (DGE); Natural Gas	57
337-2	V Appendix D – Definitions: Diesel Liter Equivalent (DLE) and Diesel Gallon Equivalents (DGE) for Compressed Natural Gas and Liquefied Natural Gas; Definition of Gasoline Gallon Equivalent and Gasoline Liter Equivalent for Compressed Natural Gas; S.1.2. Compressed Natural Gas and Liquefied Natural Gas Dispensers; S.1.3.1.1. Compressed Natural Gas Used as an Engine Fuel; S.1.3.1.2. Liquefied Natural Gas Used as an Engine Fuel; S.5.2. Marking of Diesel and Gasoline Volume Equivalent Conversion Factor; Compressed Natural Gas, S.5.3. Marking of Diesel Volume Equivalent Conversion Factor; Liquefied Natural Gas, UR.3.1.1. Marking of Equivalent Conversion Factor for Compressed Natural Gas, UR.3.1.2. Marking of Equivalent Conversion Factor for Liquefied Natural Gas, and UR.3.8. Return of Product to Storage, Retail Compressed Natural Gas and Liquefied Natural Gas	63
337-3	Appendix D – Definitions: Diesel Liter Equivalent (DLE) and Diesel Gallon Equivalents (DGE) for Liquefied Natural Gas	81

337-4	W	S.1.2. Compressed Natural Gas Dispensers, S.1.3.1.1. Compressed Natural Gas Used as an Engine Fuel, S.5.2. Marking of Gasoline Volume Equivalent Conversion Factor; Natural Gas	81
337-5		S.1.2. Compressed Natural Gas Dispensers, S.1.3.1.1. Compressed Natural Gas Used as an Engine Fuel, S.5.2. Marking of Gasoline Volume Equivalent Conversion Factor	83
337-6	D	Mass Flow Meters Code, S.3.6. Automatic Density Compensation	85
354		TAXIMETERS	89
354-1	D	USNWG on Taximeters – Taximeter Code Revisions and Global Positioning System-Based Systems for Time and Distance Measurement.....	89
358		MULTIPLE DIMENSION MEASURING DEVICES	91
358-1	D	Measurement of Bulk Material in Open-Top Truck and Trailer Units	91
360		OTHER ITEMS.....	92
360-1	D	International Organization of Legal Metrology (OIML) Report.....	92
360-2	D	Appendix D – Definitions: Remote Configuration Capability.....	95
360-3	D	Electric Vehicle Fueling and Submetering	97

Appendices

A	Item 320-2: NIST Handbook 44 – Scales, UR.2.4. Foundations, Supports, and Clearance.....	A1
B	Item 320-3: NIST Handbook 44 – Scales, Draft Tentative Code Applicable to Weigh-In-Motion Systems Used for Vehicle Enforcement Screening and proposed definitions to be added to NIST Handbook 44, Appendix D to support the Weigh-In-Motion Systems used for Vehicle Enforcement Screening – Draft Code	B1
C	Item 330-4: NIST Handbook 44 – Liquid-Measuring Devices, N.4.2.5. Determination of Error on Wholesale Devices with Multiple Flow Rates and Calibration Factors	C1
D	Item 331-1: NIST Handbook 44 – Vehicle-Tank Meters, N.4.2.1. Determination of Error on Vehicle-Tank Meters with Multiple Flow Rates and Calibration Factors.....	D1
E	Items 337-1, 337-2, 337-3, 337-4, and 337-5: NIST Handbook 44 – Mass Flow Meters, Background and Justification for NIST Handbook 44 Definition of “Diesel Gallon Equivalent (DGE)” of Natural Gas as a Vehicular Fuel.....	E1
F	Item 358-1: NIST Handbook 44 – Multiple Dimension Measuring Devices, Load Scanner Metrology, Test Methods and Suitability for Use.....	F1
G	Item 358-1: NIST Handbook 44 – Multiple Dimension Measuring Devices, Load Volume Scanner – Proposals for Integration into Handbook 44	G1
H	Item 360-3: NIST Handbook 44 – Developing Items, Electric Vehicle Fueling and Submetering.....	H1

**Table
Voting Results**

<i>Reference Key Number</i>	<i>House of State Representatives</i>		<i>House of Delegates</i>		<i>Results</i>
	<i>Yeas</i>	<i>Nays</i>	<i>Yeas</i>	<i>Nays</i>	
Consent Calendar					
310-2					Adopted
320-2					Adopted
321-1					Adopted
330-1					Adopted
330-3					Adopted
330-5A					Adopted
330-5B					Adopted
332-2					Adopted
337-2* To hear amendment	Yea: 41 Nay: 0				Amendment was heard
337-2 To amend the proposal	Yea: 29 Nay: 41				Amendment failed
338-2 as presented	29	9	14	27	Returned to Committee
To Accept the Report	Voice Vote				Adopted

* Items 232-3, 237-2 and 337-2 were voted upon as a block.

Table C
Glossary of Acronyms and Terms

Acronym	Term	Acronym	Term
API	American Petroleum Institute	MMA	Meter Manufacturers Association
AREMA	American Railway Engineering and Maintenance-of-Way Association	MPMS	Manual of Petroleum Measurement Standards
AWWA	American Water Works Association	NCWM	National Conference on Weights and Measures
BCS	Belt-Conveyor Scale	NEWMA	Northeastern Weights and Measures Association
CC	Certificate of Conformance	NIST	National Institute of Standards and Technology
CNG	Compressed Natural Gas	NGSC	NCWM Natural Gas Steering Committee
CWMA	Central Weights and Measures Association	NTEP	National Type Evaluation Program
DGE	Diesel Gallon Equivalent	OIML	International Organization of Legal Metrology
DLE	Diesel Liter Equivalent	OWM	Office of Weights and Measures
DOT	Department of Transportation	PUC	Public Utilities Commission
FALS	Fuels and Lubricants Subcommittee	RMFD	Retail Motor Fuel Dispenser
FHWA	Federal Highway Administration	S&T	Specifications and Tolerances
GGE	Gasoline Gallon Equivalent	SD	Secure Digital
GIPSA	Grain Inspection Packers and Stockyard Administration	SI	International System of Units
GLE	Gasoline Liter Equivalent	SMA	Scale Manufacturers Association
GMM	Grain Moisture Meter	SWMA	Southern Weights and Measures Association
GPS	Global Positioning System	TC	Technical Committee
IATR	International Association of Transportation Regulators	USNWG	U.S. National Work Group
IEC	International Electrotechnical Commission	WIM	Weigh-in-Motion
LMD	Liquid Measuring Devices	WWMA	Western Weights and Measures Association
LNG	Liquefied Natural Gas		

Details of All Items
(In order by Reference Key)

310 NIST HANDBOOK 44 - GENERAL CODE**310-1 D G-S.1. Identification. – (Software)****Source:**

This item originated from the NTEP Software Sector and first appeared on NCWM S&T Committee’s 2007 agenda as Developing Item Part 1, Item 1 and in 2010 as Item 310-3.

Purpose:

Provide marking requirements that enable field verification of the appropriate version or revision for metrological software, including methods other than “permanently marked,” for providing the required information.

Item Under Consideration:

Amend NIST Handbook 44: G-S.1. Identification and G-S.1.1. Location of Marking Information for Not-Built-For-Purpose, Software-Based Devices as follows:

G-S.1. Identification. – All equipment, except weights and separate parts necessary to the measurement process but not having any metrological effect, shall be clearly and permanently marked for the purposes of identification with the following information:

- (a) the name, initials, or trademark of the manufacturer or distributor;
- (b) a model identifier that positively identifies the pattern or design of the device;
 - (1) *The model identifier shall be prefaced by the word “Model,” “Type,” or “Pattern.” These terms may be followed by the word “Number” or an abbreviation of that word. The abbreviation for the word “Number” shall, as a minimum, begin with the letter “N” (e.g., No or No.). The abbreviation for the word “Model” shall be “Mod” or “Mod.” Prefix lettering may be initial capitals, all capitals, or all lowercase.*
[Nonretroactive as of January 1, 2003]
(Added 2000) (Amended 2001)
- (c) *a nonrepetitive serial number, except for equipment with no moving or electronic component parts and ~~not built for purpose software based software devices~~ software;*
[Nonretroactive as of January 1, 1968]
(Amended 2003)
 - (1) *The serial number shall be prefaced by words, an abbreviation, or a symbol, that clearly identifies the number as the required serial number.*
[Nonretroactive as of January 1, 1986]
 - (2) *Abbreviations for the word “Serial” shall, as a minimum, begin with the letter “S,” and abbreviations for the word “Number” shall, as a minimum, begin with the letter “N” (e.g., S/N, SN, Ser. No., and S. No.).*
[Nonretroactive as of January 1, 2001]
- (d) *the current software version or revision identifier ~~for not built for purpose software based electronic devices~~, which shall be directly linked to the software itself;*
[Nonretroactive as of January 1, 2004]
(Added 2003) **(Amended 20XX)**

- (1) *The version or revision identifier shall be prefaced by words, an abbreviation, or a symbol, that clearly identifies the number as the required version or revision.*
[Nonretroactive as of January 1, 2007]
(Added 2006)
- (2) *Abbreviations for the word “Version” shall, as a minimum, begin with the letter “V” and may be followed by the word “Number.” Abbreviations for the word “Revision” shall, as a minimum, begin with the letter “R” and may be followed by the word “Number.” The abbreviation for the word “Number” shall, as a minimum, begin with the letter “N” (e.g., No or No.).*
[Nonretroactive as of January 1, 2007]
(Added 2006)
- (3) **The version or revision identifier shall be accessible via the display. Instructions for displaying the version or revision identifier shall be described in the CC. As an exception, permanently marking the version or revision identifier shall be acceptable under the following conditions:**
 - (a) **The user interface does not have any control capability to activate the indication of the version or revision identifier on the display, or the display does not technically allow the version or revision identifier to be shown (analog indicating device or electromechanical counter) or**
 - (b) **the device does not have an interface to communicate the version or revision identifier.**
- (e) ~~an National Type Evaluation Program (NTEP) Certificate of Conformance (CC) number or a corresponding CC Addendum Number for devices that have a CC.~~
 - (1) *The CC Number or a corresponding CC Addendum Number shall be prefaced by the terms “NTEP CC,” “CC,” or “Approval.” These terms may be followed by the word “Number” or an abbreviation of that word. The abbreviation for the word “Number” shall, as a minimum, begin with the letter “N” (e.g., No or No.)*
[Nonretroactive as of January 1, 2003]

The required information shall be so located that it is readily observable without the necessity of the disassembly of a part requiring the use of any means separate from the device.

(Amended 1985, 1991, 1999, 2000, 2001, 2003, ~~and~~, 2006 ~~and~~ 201X)

G-S.1.1. Location of Marking Information for ~~Not-Built-For-Purpose~~ All Software-Based Devices. – For ~~not-built-for-purpose~~, software-based devices, either:

- (a) *The required information in G-S.1. Identification. (a), (b), ~~(d)~~, and (e) shall be permanently marked or continuously displayed on the device; or*
- (b) *The CC Number shall be:*
 - (1) *permanently marked on the device;*
 - (2) *continuously displayed; or*
 - (3) *accessible through an easily recognized menu and, if necessary, a submenu. Examples of menu and submenu identification include, but are not limited to, “Help,” “System Identification,” “G-S.1. Identification,” or “Weights and Measures Identification.”*

Note: For (b), clear instructions for accessing the information required in G-S.1. (a), (b), and (d) shall be listed on the CC, including information necessary to identify that the software in the device is the same type that was evaluated.

[Nonretroactive as of January 1, 2004]

(Added 2003) (Amended 2006 **and 20XX**)

Background/Discussion:

Among other tasks, the NTEP Software Sector was charged by the NCWM Board of Directors to recommend NIST Handbook 44 specifications and requirements for software incorporated into weighing and measuring devices, which may include tools used for software identification. During its October 2007 meeting, the Sector discussed the value and merits of required markings for software, including possible differences in some types of software-based devices and methods of marking requirements. After hearing several proposals, the Sector agreed to the following technical requirements applicable to the marking of software:

1. The NTEP CC Number must be continuously displayed or hard-marked;
2. The version must be software-generated and shall not be hard-marked;
3. The version is required for embedded (Type P) software;
4. Printing the required identification information can be an option;
5. Command or operator action can be considered as an option in lieu of a continuous display of the required information; and
6. Devices with Type P (embedded) software must display or hard-mark the device make, model, and serial number to comply with G S.1. Identification.

In 2008, the Software Sector developed and submitted a proposal to the NCWM S&T Committee to modify G-S.1. and associated paragraphs to reflect these technical requirements. Between 2008 and 2011, this item appeared on the S&T Committee's main agenda and the Committee and the Sector received numerous comments and suggestions relative to the proposal. The Sector developed and presented several alternatives based on feedback from weights and measures officials and manufacturers. Among the key points and concerns raised during discussions over this period were how to address the following:

- (a) **Limited Character Sets and Space.** – How to address devices that have limited character sets or restricted space for marking.
- (b) **Built-for-Purpose vs. Not-Built-for-Purpose.** – Whether or not these should be treated differently.
- (c) **Ease of Access.** – Ease of accessing marking information in the field.
 - Complexity of locating the marking information
 - Use of menus for accessing the marking information electronically
 - Limits on the number of levels required to access information electronically
 - Possibility of single, uniform method of access
- (d) **Hard Marking vs. Electronic.** – Whether or not some information should be required to be hard marked on the device.
- (e) **Continuous Display.** – Whether or not required markings must be continuously displayed.
- (f) **Abbreviations and Icons.** – Establishment of unique abbreviations, identifiers, and icons and how to codify those.
- (g) **Certificate of Conformance Information.** – How to facilitate correlation of software version information to a CC, including the use of possible icons.

Further details on the alternatives considered can be found in the Committee's Final Reports from 2008 to 2012.

Just prior to the 2013 NCWM Annual Meeting, the Software Sector forwarded to the Committee a modified version of the proposed changes to paragraph G-S.1., which the Sector had developed during its March 2013 meeting. The modified language, which is that shown in Item Under Consideration, included slight modifications to the previous proposal to address concerns received from other sectors and interested parties.

With regard to the revised proposal, the Sector reported the following:

- That the new language in G-S.1.1 reflects the Sector's consensus on the following positions:
 - The software version/revision should, with very few exceptions, be accessible via the user interface.
 - The means by which the software version is accessed must be described in the Certificate of Conformance (CC).
- After removing the "and inseparably" terminology from the proposal, the concerns on the possibility of controversy were reduced.
- The Sector's opinion on the interpretation of "directly linked" is that it means you can't change the version/revision without changing the software.
- It may be desirable to evaluate options that would lead to fully eliminating G-S.1.1. The Sector recognized that that this would be a more invasive modification to the existing handbook and perhaps should be delayed until the first step of addressing software in all devices (not just standalone) was accomplished.

See the Committee's 2013 Final Report for additional details and background information.

2014 NCWM Interim Meeting: The SMA reported that it continues to support the work of the Software Sector and encouraged communications with the other device sectors.

NIST, OWM raised two concerns relating to the most recent changes proposed by the Software Sector to subparagraph G-S.1.(d) and offered some suggestions relative to those concerns as follows:

1. Deleting the words "for not-built-for-purpose software-based electronic devices" creates the implication that all equipment manufactured as of January 1, 2004, except weights and separate parts necessary to the measurement process but not having any metrological effect, would be required to be permanently marked with a current software version or revision identifier. NIST, OWM questioned whether or not it was the Software Sector's intent to require a software version or revision identifier be marked on equipment that is not electronic. If not the intent, NIST, OWM suggested that the Sector consider adding additional text to better clarify the type of equipment intended to be addressed by this proposed change and offered the following additional text for consideration:
 - (d) the current software version or revision identifier **for software-based electronic devices**, which shall be directly linked to the software itself;
2. The proposed changes would require a current software version or revision identifier to be marked on both built-for-purpose and not-built-for purpose software based equipment manufactured as of January 1, 2004. If it is the intent of the Sector to require that a current software version or revision identifier be marked on built-for-purpose software based equipment, then the Sector might consider proposing that such a requirement be non-retroactive considering the time and cost involved in updating equipment already in service.

NIST, OWM also provided the following additional feedback on the Software Sector’s proposed changes to paragraphs G-S.1. and G-S.1.1.

- It is not clear what equipment would be affected by the proposed changes to G-S.1.(c). By proposing that the word “software” be added, is the exception intended to apply to the software itself or to equipment in which the software is installed?
- In the proposed additions to G-S.1.(d)(3)(a), it is not clear what is meant by the phrase “or the display does not technically allow the version or revision identifier to be shown.” The examples “analog indicating device” and “electromechanical counter” are confusing. NIST, OWM doesn’t believe these examples provide enough information to lead one to conclude that the intent is to address such things as numeric-only displays. For example, numeric-only displays that don’t have the capability of displaying abbreviations for “version” or “revision” as noted in earlier comments originating from the Sector.
- NIST, OWM recommends adding some examples to clarify the types of devices described in paragraph G-S.1.(d)(3)(b).
- NIST, OWM agrees with the Software Sector’s assertion that it may be possible to eventually eliminate G-S.1.1. at some future date.

The Committee expressed appreciation for the efforts of the Software Sector; but also noted the concern that this item had remained on its agenda for a long time with little progress. Recognizing the difficulty in developing a proposal that meets the needs of multiple groups, the Committee agreed to maintain the item on its agenda to allow the Sector to finalize work on this issue. The Committee made clear in its report, however, that if no progress was made in the next year, it planned to withdraw the item from its agenda. This would not preclude the Sector from resubmitting the item at some point in the future when additional work had been done or the item had been fully developed.

During the 2014 NCWM Annual Meeting, the SMA reiterated its support of the Software Sector’s work and looked forward to the outcome of an August 2014 joint meeting of the Weighing and Software Sectors.

NIST, OWM reiterated the comments, concerns, and feedback it provided during the 2014 NCWM Interim Meeting and that are reflected in the Committee’s Interim Report. NIST, OWM noted that an August 2014 joint meeting of the Software and Weighing Sectors is planned to consider the current proposal and to try and reach agreement on the changes needed to paragraph G-S.1. NIST, OWM encouraged the two Sectors to consider its comments and feedback when considering any changes to the language currently proposed for G-S.1. The approach used in the past has been for the sectors to review the proposal in separate meeting sessions; however, this has not resulted in a proposal amenable to all Sectors. NIST, OWM believes that it might be more expedient for all of the sectors to collaborate in a single joint meeting to try and reach agreement on the changes needed.

The Committee maintained its earlier position to withdraw this item at the 2015 NCWM Interim Meeting if progress on this item has not been made.

There were two positions from industry members posted on NCWM’s 2014 Online Position Forum; one in support of the proposal and the other opposed to it. There were also two written comments posted.

Regional Association Comments:

CWMA recommended at their 2013 Interim Meeting that this item remain as a Developing Item and that the item be returned to the Software Sector to write a definition for software-based devices. During its 2014 Annual Meeting, CWMA supported continued development of the item and recommended it remain a Developing Item.

WWMA agreed at their 2013 fall meeting that this item has merit, but it needed further development. The WWMA also acknowledged that three regions recommended the item remain Developing. WWMA reported that it looked forward to hearing the results of the Weighing and Software Sector’s joint meeting and recommended that this item remain as a Developing Item.

NEWMA recognized during its 2013 Interim Meeting that the Committee had requested input on this item from the sectors and industry during the 2013 NCWM Annual Meeting. NEWMA reported that it anticipated some new developments that could move the item forward and recommended the item be maintained as “Developing.” During its 2014 Annual Meeting, NEWMA noted that development of the item is still ongoing and again recommended it remain as a Developing Item.

SWMA received a presentation by Mr. Doug Bliss (Mettler Toledo) during its 2013 fall meeting on behalf of the Software Sector. The SWMA considered recommending this as a Voting Item due to the length of time it has been on the agenda, but comments received indicated that progress would be made in the next year and, with this information, the Committee recommends it be maintained as a Developing Item.

See previous Reports of the National Conference on Weights and Measures for additional history on this item.

310-2 VC G-S.5.6. Recorded Representations

(This item was Adopted.)

Source:

Liquid Controls (2014)

Purpose:

Address the issue of receipt (printed, electronic, and optional).

Item Under Consideration:

Amend NIST Handbook 44 General Code as follows:

G-S.5. Indicating and Recording Elements.

G-S.5.6. Recorded Representations. – Insofar as they are appropriate, the requirements for indicating and recording elements shall also apply to recorded representations. All recorded values shall be printed digitally. **In applications where recorded representations are required, the customer may be given the option of not receiving the recorded representation. For systems equipped with the capability of issuing an electronic receipt, ticket, or other recorded representation, the customer may be given the option to receive any required information electronically (e.g., via cell phone, computer, etc.) in lieu of or in addition to a hard copy.**

(Amended 1975 **and 2014**)

Background/Discussion:

NCWM 2013 Annual Meeting: Members expressed support for including requirements to address the use of electronic receipts in the General Code rather than in individual device codes. Including requirements in the General Code would eliminate confusion and inconsistency, consolidate provisions from individual codes, and confine future updates to a single code.

The concept of providing receipts electronically is incorporated in certain provisions of the Liquid-Measuring Devices Code. Similar provisions are needed in other specific NIST Handbook 44 codes. Inserting a single provision in the General Code to address the use of electronic receipts will be more efficient than proposing changes to multiple individual codes and will eliminate inconsistencies among sections.

Some concerns have been raised that recognition of electronic receipts could lead to the elimination of printed receipts, particularly for customers who have limited access to the internet, smart phones, and other electronic access. However, the proposal is written to ensure that the printed receipt remains an option for the customer.

A summary of the proposed changes is as follows:

- If a receipt is required, allow the customer to decline the option of receiving any type of receipt.
- Add an option of electronic receipt as long as the system has the capability of generating electronic receipts.
- If a receipt is desired, allow customer to select between printed and electronic receipt; or both.
- Remove references to electronic receipts from the Liquid-Measuring Devices Code as they will be redundant.

See Item 330-5 for related background and discussions. See also Item 330-1 for a related proposal.

2014 NCWM Interim Meeting: Mr. Steve Langford (Cardinal Scale Manufacturing), speaking on behalf of the SMA, stated that the SMA could see no harm in giving the consumer the option of not receiving the recorded representation or receiving the recorded representation in alternative forms. The SMA supported the item as written.

NIST, OWM noted that weighing and measuring equipment that has the capability of issuing an electronic receipt exists, yet the information contained on the receipt is not required by NIST Handbook 44. For example, nowhere in NIST Handbook 44 is it required that a printed ticket from a scale that is not part of a POS system contain certain information. For this reason, NIST, OWM finds the use of the word “the” immediately preceding the word “required” in the second sentence of the proposal somewhat confusing and recommended replacing the word “the” with the word “any” so that the sentence reads as follows: For systems equipped with the capability of issuing an electronic receipt, ticket, or other recorded representation, the customer may be given the option to receive the any required information electronically (e.g., via cell phone, computer, etc.) in lieu of or in addition to a hard copy.

NIST, OWM also noted that Item 330-1 includes a corresponding proposal. Should the Committee decide to advance Items 310-2 and 330-1, the Committee should give consideration to consolidating them into a single item for NCWM action. See also Items 331-1 LPG Code Modifications (UR.2.8.) and 332-2 (S.1.5.3. Recorded Representations, Point-of-Sale Systems, LPG Code) which may also be impacted by action on Item 310-2.

Ms. Fran Elson-Houston (Ohio and Chair of the Task Group (TG) on RMFD Price Posting and Computing Capability) stated that the TG on RMFD Price Posting and Computing Capability supports this item. Mr. Gordon Johnson (Gilbarco, Inc.) also supported the item. Mr. Michael Keilty (Endress & Hauser Flowtec AG USA) commented that an electronic failure would lead to consumers being unable to receive a receipt.

The Committee agreed with NIST, OWM’s assessment that not all weighing and measuring equipment equipped with the capability of issuing an electronic receipt, ticket or recorded representation is explicitly required to provide certain information on the receipt or ticket. For example, NIST Handbook 44 does not require any of the information that typically gets recorded onto a printed ticket generated from a stand-alone small capacity computing scale used in a direct sale application. NIST Handbook 44 does require any information that is provided on the receipt or ticket of such a scale to be accurate and clearly identified. For this reason, the Committee concluded that the use of the word “the” in the second sentence of the proposal may lead to confusion and agreed to replace that word with the word “any” as suggested by NIST, OWM and shown in the “Item Under Consideration.” The Committee acknowledged that there are potential overlaps with this item and Items 330-1, 330-5B, 332-1, and 332-2, which could lead to potential conflicts if this item is adopted. The Committee plans to address any conflict which might arise by modifying those items prior to presenting them for a vote.

NCWM 2014 Annual Meeting: The Committee heard comments from Mr. Ross Andersen (New York retired), reporting that he wished to explain comments that he had posted on NCWM’s On-line Position Forum. *NIST Technical Advisor’s note: Mr. Andersen had opposed the item on NCWM’s On-line Position Forum and posted comments supporting that position.* Mr. Andersen stated that the option for customers to receive information electronically is probably already provided in each state’s public records law. He suggested that the text proposed

for addition to paragraph G.S.5.6. does not relate to the design of a device and therefore should not be part of a “Specification” requirement. It would be the device owner/operator’s responsibility to provide customers the option of not receiving the recorded representation or to receive any required information electronically. Thus, it was his view that the proposed text for addition would be more appropriately represented as a user requirement. He referenced the “System of Paragraph Designation” Section in the Introduction portion of NIST Handbook 44, noting that “Specification” paragraphs relate to the design of equipment; “User Requirements” are directed particularly to the owner and operator of a device, and apply to the selection, installation, use, and maintenance of devices. Mr. Andersen also acknowledged that not all customers have “Smart” phones, and consequently took the position that any ability to offer electronic receipts should not preclude customers from being able to receive a hard copy receipt.

Mr. Dmitri Karimov (Liquid Controls), submitter of the item, agreed with comments provided by Mr. Andersen, noting that the intent of the proposal is to streamline NIST Handbook 44 by eliminating “Specification” requirements in many device codes and replacing them with a single General Code requirement that applies to all devices. He acknowledged that the proposed language may not be perfect, but suggested moving the item forward as proposed and possibly refining it later.

Mr. Michael Keilty (Endress Hauser Flowtec AG) commented that he wouldn’t want to see the text being proposed for addition included in a User Requirement as suggested by Mr. Andersen. If that were the case, the requirement might be interpreted to apply only to the owner of the equipment and not the user, which is the customer. The intent of this proposal is for the customer to be in charge of deciding whether he/she wants the receipt, and, if so, the form (hard copy or electronic) in which he/she wishes to receive it. The proposed language could be strengthened to ensure customers are provided the option of receiving required information in hard copy or in electronic form.

NIST, OWM commented that as a general rule, it favors the elimination of similar requirements in different device codes of the Handbook; that is, those requirement which address the same issue or concern over a single requirement in the General Code that can be applied consistently throughout all codes. Many of the points made by Mr. Ross Andersen in comments posted on the NCWM’s On-line Position Forum are well taken. NIST, OWM suggested that rather than delay changes that would immediately clarify that an electronic receipt is an acceptable alternative, the Committee proceeded with the item as proposed. However, in recognition of the validity of Mr. Andersen’s points, NIST, OWM suggested the Committee consider developing a new item for submission in the next NCWM cycle. This item could explore the development of a new General Code User Requirement that would require users of equipment to provide customers a receipt of all information required to be recorded by a device (or system). This paragraph could be added to either replace the text proposed for addition to G-S.5.6. or to compliment it as a stand-alone paragraph.

With respect to the comments provided by Mr. Andersen, Mr. Karimov, and NIST, OWM, the Committee received a number of additional comments mostly in favor of moving the item forward as proposed (i.e., as a “Specification”) with the understanding that the Committee considers developing a new item for submission in the next NCWM cycle as suggested by NIST, OWM.

The SMA reiterated the comments provided during the NCWM Interim Meeting in support of the item.

The Committee agreed with comments suggesting that this item might be better suited as a “User Requirement,” but also that, while the creation of a user proposal may have merit, the proposed changes to paragraph G-S.5.6. should not be delayed. The Committee agreed to recommend the item as shown above in the “Item Under Consideration” for a vote, noting that should there be a strong desire within the community to develop a proposal for a supplemental user requirement, it would be amenable to considering such a proposal in the future.

There were three positions posted on NCWM’s 2014 Online Position Forum; two from industry in support and one from government opposed.

Regional Association Comments:

CWMA reported that comments were heard during their 2013 Interim Meeting regarding the ability of weights and measures officials to review receipts in an electronic format (e.g., delays, ability to retrieve, etc.) and that it believed the proposal adequately addressed these concerns. Consequently, the CWMA supported moving the item forward as

a Voting item. At their 2014 Annual Meeting, the CWMA reported that it believes the item has been sufficiently developed and recommended the item be a Voting Item. NEWMA supported the item moving forward as a Voting item during their 2014 Annual Meeting and reported that the proposed changes recognize the evolution of a transaction between buyer and seller and new technologies used to deliver receipts other than printed documents. This language is necessary to recognize new technology and address it in NIST Handbook 44.

SWMA noted at their 2013 fall meeting that it did not receive any comments opposing this item when it met in 2013, reported that the item has merit and should be considered by the NCWM S&T Committee.

320 SCALES

320-1 W S.2.1.6. Combined Zero-Tare (“0/T”) Key

(This item was Withdrawn.)

Source:

California Division of Measurement Standards (2014)

Purpose:

Allow a combined “zero/tare” feature under specified conditions.

Item Under Consideration:

Amend NIST Handbook 44, Scales Code as follows:

S.2.1.6. Combined Zero-Tare (“0/T”) Key. – The semi-automatic zero-setting and the semi-automatic tare-mechanism can be operated by the same key on Class I, II, and III scales with digital indications provided that:

- (a) **The overall effect of semi-automatic zero-setting and zero-tracking mechanisms shall be not more than 4 % of the maximum capacity; and**
- (b) **Either automatically maintain a “center-of-zero” condition to $\pm \frac{1}{4}$ scale division or less, or have an auxiliary or supplemental “center-of-zero” indicator that defines a zero-balance condition to $\pm \frac{1}{4}$ of a scale division or less. A “center-of-zero” indication may operate when zero is indicated for gross and/or net mode(s).**

~~Scales not intended to be used in direct sales applications may be equipped with a combined zero and tare function key, provided that the device is clearly marked as to how the key functions. The device must also be clearly marked on or adjacent to the weight display with the statement “Not for Direct Sales.”~~

Background/Discussion:

Various scale manufacturers have manufactured or imported Class II scales that are equipped with a combined zero/tare button for jewelry sale/purchase applications. Many of these scales are in use in direct retail sales, particularly in the purchasing of gold, silver, and other precious metals and stones. It has not been demonstrated, or documented, how the combination of tare/zero function causes fraud if the feature complies with the following similar clause in OIML R 76: Automatic Indicating Weighing Instruments:

4.6.9 Combined zero-setting and tare-balancing devices

If the semi-automatic zero-setting device and the semi-automatic tare-balancing device are operated by the same key, 4.5.2 (*zero within $\pm 0.25 e$*), 4.5.5 (*zero within $\pm 0.25 e$*) and if appropriate 4.5.7 (*operation of zero-tracking*) apply at any load.

The existence of a unique “type-approved” scale which cannot be used in a “direct sales” transaction, combined with the fact that so many of these scales are being sold by manufacturers and distributors into direct sales applications without the required statement “Not For Use in Direct Sales” has caused confusion. It is believed that this proposal would be preferable to legal actions against the manufacturers for failing to meet conditions on the type-approval certificate because they failed to place the required “Not for Direct Sales” statement on their machines without demonstrated harm to customers. Additionally, it appears that the combination zero/tare feature in NIST Handbook 44 Scales Code paragraph S.2.1.6. is not addressed in NCWM Publication 14 checklist for Digital Electronic Scales.

An argument against the amendment is the inability for a customer to see the “net” weight indication when all (intended) tare values are less than 4 % of the capacity of the scale. However, at least one manufacturer submitted a scale with the 0/T feature without the required marking that was not evaluated due to omissions on the NTEP application. The NTEP CC has been active for several years with nearly 20 000 scales sold in California alone. Weights and measures jurisdictions in California have not reported any complaints or made observations that the feature was used to facilitate inaccurate transactions.

This subject was originally considered by the NTEP Weighing Sector in 1997 and paragraph S.2.1.6. was subsequently adopted by the NCWM in 1998. During the deliberations of Specifications and Tolerances (S&T) Committee Agenda Item 220-3, the Weighing Sector stated that “because it is common to find tares taken in direct sales operations that are less than seven divisions (7d), they were concerned over the use of this feature in direct sales applications. The laboratories consider these devices acceptable in applications where there would be a clear understanding of the “zero/tare” key function provided: (1) there are clear and definite markings on the scale adjacent to the zero tare key with a statement describing its operation (e.g., for the scale in the example given “Zero up to 7d; tare over 7d” or similar wording); and (2) the scale must be clearly and definitely marked with the statement “Not for Use in Direct Sales to the Public.” The NCWM S&T Committee noted that jurisdictions vary in the type of operations which are considered “direct sales.” For instance, only some jurisdictions consider produce grading and meat room packaging scales to be “direct sale” applications. The Committee felt that the classification of an operation should be left to the jurisdiction. The Committee recommended that devices equipped with a “0/T” key be clearly and permanently marked with: (1) a description of how the key functions; and (2) the statement “Not for Direct Sales” adjacent to the display on both the customer’s and operator’s side of the device.

NCWM 2014 Interim Meeting: The SMA opposed the inclusion of Class III devices in the proposal and the 4 % maximum overall effect of semi-automatic zero-setting and zero-tracking mechanisms imposed by the proposal. The SMA noted that NIST Handbook 44 does not limit the zeroing effect of a semi-automatic zero setting mechanism. The SMA also noted that S.1.1.1.(b) is redundant and that if each of these references were removed, there would be no point in making any changes to the paragraph.

The Committee also heard from Mr. Lou Straub (Fairbanks Scales) opposing the inclusion of Class III scales in the proposal.

The Committee heard concerns from NIST, OWM regarding the fact that, should the combined “0/T” key be permitted on scales used in direct sales, there will not be a clear indication that a weighing operation starts with the scale on zero or that tare has been taken, and therefore, the feature may not provide adequate consumer protection in direct sale applications. Additionally, the proposal only addresses semiautomatic zero setting and semiautomatic tare mechanisms and doesn’t restrict other types of tare or zero from being used, which might possibly facilitate the perpetration of fraud.

Ms. Angela Godwin (Ventura County Department of Weights and Measures) and Mr. John Young (Yolo County California Agriculture Department) provided comments in support of the proposal.

In considering this item, the Committee first questioned the availability of Class II scales in the marketplace that have been issued an NTEP CC and could be considered suitable for use in direct sale applications. The Committee concluded that there are numerous Class II scales available for purchase meeting these criteria. The Committee then considered whether it’s appropriate to change NIST Handbook 44 to allow scales equipped with a combined “0/T” key be used in direct sale applications. The Committee agreed that it would not be appropriate given the number of available Class II scales already in the marketplace that have been designed for direct sale applications, the concerns

raised by NIST, OWM, and the opposition expressed by the SMA. Consequently, the Committee agreed to withdraw this item from its agenda.

At their spring 2014 Meeting, the SMA supported the withdrawal of this item.

Regional Association Comments:

The WWMA reported at their fall 2013 meeting that it had received similar proposals on this item. The first proposal by Mr. Paul Jordan (Ventura County California) was withdrawn by the submitter and the second proposal by Mr. Steve Cook (California) was recommended. The WWMA after hearing testimony from Ms. Juana Williams (NIST, OWM) and Mr. Darrell Flocken (Mettler Toledo) had concerns about the need for this section in NIST Handbook 44. The WWMA recommended that Mr. Cook meet with the Weighing Sector to determine whether or not there is a need for this section and, if so, consider if 4 % of the scale capacity is an appropriate limit. WWMA forwarded this item to NCWM, recommending that it be a Developing item.

WWMA heard comments in support of the item at their fall 2013 meeting, but had some concerns about the 4 % limitation. There were also issues regarding the need for the limitation on such a small market of scales in commercial applications. The Committee recommended the item continue to be developed. SWMA forwarded the item to NCWM.

320-2 VC UR.2.4. Foundations, Supports, and Clearance

(This item was Adopted.)

Source:

Schenck Process Inc. (2014)

Purpose:

Allow for an in-motion rail scale to have a continuous rail on the approach and weighing area. Such a design is presently in conflict with Scales Code paragraph UR.2.4., which states “clearance shall be provided around all live parts to the extent that no contacts may result when the load-receiving element is empty, nor throughout the weighing range of the scale.”

Item Under Consideration:

Amend NIST Handbook 44, Section 2.20. Scales as follows:

UR.2.4. Foundation, Supports, and Clearance. – The foundation and supports of any scale installed in a fixed location shall be such as to provide strength, rigidity, and permanence of all components, and clearance shall be provided around all live parts to the extent that no contacts may result when the load receiving element is empty, nor throughout the weighing range of the scale. **An in-motion railway track scale is not required to provide clearance using rail gaps to separate the live rail portion of the weighing/load-receiving element from that which is not live if the scale is designed to be installed and operated using continuous rail.** *On vehicle and livestock scales, the clearance between the load receiving elements and the coping at the bottom edge of the platform shall be greater than at the top edge of the platform.**
[*Nonretroactive as of January 1, 1973]

(Amended 2014)

Background/Discussion:

Schenck Process, Inc. is presently testing a scale called the “MultiRail,” that is used to weigh rail cars in-motion and statically and which does not require the rail to be cut prior to the weighing area. During the August 2013 Weighing Sector meeting, the Sector recommended that the requirement for rail gaps that is presently in the checklist/procedures section of Publication 14 be removed.

This equipment was also presented to the AREMA Scales Committee 34 at the October 2013 meeting in Nashville, Tennessee. Discussions have previously been held with Committee 34 regarding the “MultiRail” scale, and Committee 34 wants to ensure the equipment complies with weighing accuracies in NIST Handbook 44.

The Schenck MultiRail is new technology for weighing rail cars in the US, but it has been used around the world and is OIML approved.

Testing of the system has been on-going at the American Association of Railroads test center in Pueblo, Colorado, for over one year. These tests have proved the durability of the design, since over 350 million gross tons have crossed the system during this period and NTEP testing is now being conducted in conjunction with GIPSA.

This issue was also presented to the NTEP Committee at the 2013 NCWM Interim Meeting and Schenck Process agreed to install equipment and pass the NTEP test for static and in-motion weighing. When the testing was completed, Schenck advised they wanted to have the requirement for rail gaps removed from NCWM Publication 14 and a CC issued for the device.

NCWM 2014 Interim Meeting: Dr. Ulrich Rauchschalbe (Schenck Process, Inc.) provided a presentation regarding the operation of a Schenck in-motion railway track scale, which does not use rail gaps to separate the live rail portion of the weighing/load receiving element from portions of the rail that are not live. That is, continuous rail is used throughout. Dr. Rauchschalbe clarified that the application of this railway track scale is restricted to coupled-in-motion and uncoupled-in-motion weighing and is not intended to be used commercially for static weighing, although there may be instances where the scale could be used statically as a reference scale. That is, the scale could be used statically to determine the reference weights of railcars selected for use in conducting an uncoupled-in-motion or coupled-in-motion test of the scale. Mr. Ed Luthy (Schenck Process, Inc.) indicated that NTEP evaluations have successfully been completed on a device of this design.

Mr. Rafael Jimenez (AAR Transportation Technology Center) commented that the AAR supports the proposal as written.

Mr. Steve Beitzel (Systems Associates, Inc.) questioned whether enough U.S. data is available to be able to properly evaluate the performance of the system, noting that “railroading” is much different in the United States than in Europe. More U.S. field experience using the system is needed because trains travel at faster speeds in Europe and railcar loads are significantly heavier in the United States. Mr. Beitzel also questioned the impact of shear forces on device performance and the degree of sensitivity of the device relative to longitudinal or vertical forces that result from the use of continuous rail installed over the weighing/load-receiving element of the scale.

NIST, OWM noted that some of the written comments and suggestions it provided to the Committee in advance of the 2014 NCWM Interim Meeting had been addressed, although perhaps not fully, in the presentation provided by Dr. Rauchschalbe. NIST, OWM provided the following written comments to the Committee in advance of the meeting:

- It might be helpful if additional information concerning the technology used and/or the safeguards incorporated into the design of the scale system were made available by the manufacturer of the equipment. Once made available, this information could be used to make an informed decision on whether or not adequate protections have been incorporated into the design of the equipment to ensure weighments will be accurate under normal service conditions and adjustments will remain reasonably permanent. This information might also be beneficial in determining whether or not additional Specification and/or User Requirements are needed.
- One particular issue needing explanation is how an in-motion railroad weighing system, which uses continuous rail (no rail gaps), is able to differentiate between loads applied to the live portion of the weighing/load-receiving element of the scale and loads approaching the live portion, but not yet having arrived, and where the separation occurs between live and dead rail (if in fact there is such a separation). More specifically, how are weight influences from approaching cars in a train filtered out by the system that they have no effect on railcars that are being weighed?

- The intended application of the railroad weighing system needs to be clarified. The proposed footnote to be added specifies “coupled-in-motion railway track scale,” but the “Purpose” of the item specifies “static or in-motion,” leading one to believe the application could be any type of railroad weighing system.

In considering this item, members of the Committee agreed that, based on the presentation and the comments provided during the Open Hearings, which confirmed the NTEP evaluations had been successfully completed, this item was ready for vote. Consequently, the Committee agreed to recommend the item as shown above in the “Item Under Consideration” for a vote.

NCWM 2014 Annual Meeting: Dr. Rauchschalbe provided a presentation, similar to the one given during the 2014 Interim Meeting, regarding the operation of the Schenck MultiRail in-motion railway track scale. A copy of his presentation slides is included in Appendix A. Dr. Rauchschalbe reported that there are over 300 commercial installations of the scale worldwide. Dr. Rauchschalbe responded to a number of questions from the Committee and the audience.

The Committee received numerous industry comments in support of the proposal. Some of the more significant comments heard in support of the proposal are as follows:

- The scale has passed NTEP’s evaluation for both static and in-motion weighing. The intended application is for in-motion railroad weighing.
- The procedures for reference car weighing in static mode are just like those used for any other static railroad scale.
- We’ve received many requests for the scale (comments from a scale installer). The scale will serve a great need. There is much less rail down time during installation compared to other railcar weighing systems.
- Gaps in the rail create a maintenance problem. Stones, ice, debris, etc., can get lodged in the gap between the live and dead rails causing binding. Also, rails expand when exposed to heat causing a lessening of the gap to the extent that sometimes the live and dead rails contact one another. Having no rail gap is a step forward.
- We operate the first ever Schenck MultiRail in-motion railroad scale installed in the United States for commercial application (comment from PBF Energy, DE.). The scale is accurate and durable. We’ve completed over 9100 weighings at speeds up to seven miles per hour and at an accuracy of 0.2 percent. Installation was completed over a weekend on track that could not be taken out of service.

NIST, OWM noted that it was stated during the 2014 NCWM Interim Meeting S&T open hearings that the “MultiRail” scale is not intended to be used commercially for static weighing, although there may be instances where the scale could be used statically as a reference scale. NIST, OWM interpreted that comment to mean that there may be instances where the scale could be used statically to determine the reference weights of railcars selected for use in conducting an uncoupled-in-motion or coupled-in-motion test of the scale. If that interpretation is correct, NIST, OWM believes it would be important for the manufacture to provide instructions for using the scale in a static mode to weigh the reference test cars. That is, the procedures that would need to be followed in order to attain the degree of accuracy necessary to be able to use those railcars as a standard in testing a coupled-in-motion or uncoupled-in-motion railway track scale, whichever the case may be. As a reminder, NIST, OWM noted that in order to qualify as a standard in testing commercial weighing and measuring equipment, the Fundamental Considerations of NIST Handbook 44 requires the combined error and uncertainty of the standard to be less than one-third the applicable device tolerance when the standard is used without correction.

With respect to the scale’s use as a reference scale, NIST, OWM suggested that if the determination is made that the “MultiRail” scale isn’t capable of providing accurate enough weight determinations for the scale to be used to establish the reference weights of railcars, then a User Requirement may need to be added to the Scales Code of NIST Handbook 44 making it the user’s responsibility to ensure there is a suitable reference scale available for this purpose.

The SMA supported the item, commenting it feels that restrictions limiting technology should be eliminated.

Mr. Rafael Jimenez (AAR Transportation Technology Center) commented that the AAR supports the proposal as written.

The Committee agreed to recommend the item be presented for vote as shown in “Item Under Consideration,” hearing numerous comments in support of the proposal and no comments in opposition.

There were two positions from industry members posted on NCWM’s 2014 Online Position Forum in support of the proposal.

Regional Association Comments:

CWMA recommended the item as “Developing” during their 2013 Interim Meeting, noting the following reasons:

- The NTEP evaluation is incomplete.
- This is an emerging technology; a new code(s) may be appropriate for this type of device.
- There hasn’t been enough data provided to show if this device is suitable for use in this application.

At their 2014 Annual Meeting, CWMA reported that it believed the item had been sufficiently developed and recommended it move forward for a vote.

NEWMA forwarded the item to NCWM and recommended it as a Voting Item at their 2014 Annual Meeting. NEWMA reported that it believes the item has been fully developed, the technology has been tested, the NTEP evaluation has been successfully completed, and the device suitable for use its intended application.

SWMA worked with the submitter this of item and editorially corrected it during the Committee work session in 2013. The Committee heard comments in support of the item from the Weighing Sector and other scale manufacturers. The Committee supported this item as a Voting Item and forwarded it to NCWM.

320-3 I Part 2.20. Weigh-In-Motion Vehicle Scales for Law Enforcement – Work Group

Source:

NIST, OWM, Mr. Richard Harshman, on behalf of the U.S. Federal Highway Administration (FHWA) (2011)

Purpose:

To provide the U.S. weights and measures community (equipment manufacturers, weights and measures officials, truck weight enforcement officials, and other users) with legal metrology requirements to address WIM systems used for vehicle enforcement screening.

Item Under Consideration:

Adopt the proposed Section 2.25. Weigh-In-Motion Systems Used for Vehicle Enforcement Screening Code shown in Appendix B as a tentative code in NIST Handbook 44, and adopt the proposed definitions of terms used in the tentative code (also included in Appendix B) into NIST Handbook 44 Appendix D - Definitions.

Background/Discussion:

The nation’s highways, freight transportation system, and enforcement resources are being strained by the volume of freight being moved and the corresponding number of commercial vehicles operating on its roads. Traditional, static-based vehicle inspection activities simply cannot keep pace with anticipated truck volume increases. Current U.S. Department of Transportation (DOT) forecasts project freight volumes to double by 2035 and commercial vehicles to travel an additional 100 billion miles per year by 2020. WIM technology has been targeted by FHWA and Federal Motor Carrier Safety Administration as a technology capable of supporting more effective and efficient truck weight enforcement programs.

Several DOT efforts are underway and planned for the future to maintain adequate levels of enforcement that ensure equity in the trucking industry market and protection of highway infrastructure. Judicial support for enforcement decisions to apply more intense enforcement actions on specific trucks depends on support from the U.S. legal metrology community. Standards are needed in NIST Handbook 44 to address the design, installation, accuracy, and use of WIM systems used in a screening/sorting application. The implementation of a uniform set of standards will greatly improve the overall efficiency of the nation's commercial vehicle enforcement process.

Once adopted by the truck weight enforcement community, these requirements will enhance the accuracy of the nation's WIM scale systems; serve as a sound basis for judicial support of next-generation truck weight enforcement programs; and result in fewer legally loaded vehicles being delayed at static weigh station locations, thus reducing traffic congestion and non-productive fuel consumption and improving the movement of freight on our nation's roadways.

Purpose of the Project:

The FHWA's Office of Freight Management and Operations recognized a need to encourage uniformity in the design, testing, installation, and performance of WIM technology and subsequently encourage acceptance by prosecution agencies (administrative or judicial) regarding the validity of WIM technology's role in supporting commercial motor vehicle weight enforcement.

In response to this need and recognizing the value of having a standard included in NIST Handbook 44 because it lends integrity and is more recognizable in legal actions, the FHWA seeks to integrate WIM technology into the Handbook. The FHWA contracted the services of the Texas Transportation Institute of the Texas A&M University System and Battelle (a private company) to begin this process. Additionally, a small oversight Committee was formed by the FHWA, made up of three representatives from the FHWA, NIST, and a U.S. manufacturer of WIM equipment to validate that each contract deliverable is completed according to contract. NIST, OWM also agreed to provide a technical advisor to the associated work group tasked with development of the proposed code.

The intended application of the proposed new code is for screening purposes only (i.e., for screening/sorting commercial vehicles for possible violations of FHWA vehicle weight requirements).

To view a detailed summary on the progress of this project since its inception in December 2011 through 2012, refer to "Timeline of Completed Tasks Relating to the Project" in S&T Agenda Item 360-3 in the Committee's 2012 Final Report. Refer to the Committee's 2013 final report for additional background information.

NCWM 2014 Interim Meeting: The WIM Project Leader, Mr. Tom Kearney (USDOT - FHWA) provided an update on the progress of development of the draft code. Mr. Kearney indicated that the WG had planned to convene during the fall of 2013 to address the three concerns raised by NIST, OWM during the 2013 NCWM Annual Meeting, but was unable to do so because of scheduling conflicts. Since the 2013 NCWM Annual Meeting, a WG member from the Netherlands had submitted some new comments concerning the draft code. The purpose of the next WG meeting will be to address the three NIST, OWM concerns and to review the new comments from the Netherlands. That WG meeting would likely take place in April or May 2014. It was hoped that revisions to the draft code could be completed shortly thereafter so that a revised copy of the draft code could be made available to members of the weights and measures community prior to the NCWM Annual Meeting in July 2014. In the meantime, the WG continues to seek input on the current draft from anyone wishing to do so.

The SMA commented that it continues to support the efforts of the WG and looks forward to seeing the next draft of the proposed Code.

Mr. Steve Langford (Cardinal Scale Manufacturing Co. and member of the FHWA's Project Oversight Committee) also voiced his support of the efforts of the WG.

The Committee agreed to maintain the Informational status of the item and looks forward to further development of the draft code by the WG.

During the 2014 NCWM Annual Meeting, Mr. Rick Harshman, NIST Technical Advisor, to the WIM WG provided an update on the progress of the draft code, including changes agreed to by the WG during their most recent meeting held in Washington, D.C. in June 2014. Mr. Harshman thanked the WIM WG for agreeing to meet to consider NIST, OWM's three comments relative to the draft code and that NIST, OWM's concerns relating to those three comments had been satisfied during that meeting. During the meeting, the WG agreed to the following:

- To amend the draft code by specifying that a three independent platform vehicle scale be used to establish the reference test loads for axle, axle-group, and total vehicle weight, which are needed in the testing of a WIM system. NIST, OWM considers the three platform vehicle scale the "best option" to being able to establish accurate reference standards for testing when considering the different scale types available.
- Add a "note" and an additional "table" to the draft code making clear their decision of allowing higher accuracy classes to be added to the code in the future providing it can be demonstrated that WIM systems grouped within those accuracy classes can achieve the higher level of accuracy specified for those classes.
- With respect to NIST, OWM's suggestion to the WG to consider adding approach requirements, the WG didn't believe approach requirements were currently needed based on the large tolerances specified in the draft code for a Class A device. The WG did agree with NIST, OWM's assertion that the introduction of higher accuracy classes in the future would likely dictate the need to include approach requirements.

Mr. Harshman indicated that the next step would be to submit the revised draft code to the regional associations for consideration during their fall meetings.

Mr. Langford provided comment in support of the draft code and reported that it had already been revised to reflect the changes agreed to by the WG. He requested that the regional associations review the draft code at their next meeting.

The SMA reported that it supported the efforts of the work group and looked forward to seeing the next draft of the proposed code.

Mr. Lou Straub (Fairbanks Scales) stated that Fairbanks supplies WIM devices and supports the draft code moving forward.

The Committee agreed to maintain the item as "Informational" based on the comments provided. A copy of the most recent draft code (i.e., Revision 2) is included in Appendix B.

There was one industry position posted on NCWM's 2014 Online Position Forum in support of the proposal.

Regional Association Comments:

The CWMA did not receive any additional comments on this item during their 2013 Interim Meeting and 2014 Annual Meeting and recommended that this item remain as an Informational Item.

WWMA recognizes the efforts by the WIM WG and Mr. Darrell Flocken (Mettler Toledo and Chair of the WG) comments that updated the Conference on the progress of the WG during their 2013 Annual meeting. The WWMA looks forward to hearing the results of the WIM WG meeting. WWMA recommended that this item be an Informational item.

During their 2013 Interim meeting, NEWMA reported that it awaits final language from the Work Group and recommended that the item be an Informational Item. During their 2014 Annual Meeting, NEWMA reported that work on this item is still ongoing and recommended the "Informational" status be maintained pending the outcome of the June 2014 WIM WG Meeting.

SWMA received a Work Group report from Mr. Flocken at their fall 2013 meeting. The Committee did not have a recommendation on this item. Based on comments received, the Committee supported further development of the draft code by the WIM Work Group.

See previous Reports of the National Conference on Weights and Measures for additional history on this item.

321 BELT-CONVEYOR SCALE SYSTEMS

321-1 VC UR.1.2. Conveyor Installation

(This item was Adopted.)

Source:

U.S. National Work Group on Belt-Conveyor Scales (2014)

Purpose:

Simplify the requirement for belt tension by making it consistent regardless of belt length without prescribing the type of device to accomplish this.

Item Under Consideration:

Amend NIST Handbook 44 Belt-Conveyor Scale Systems Code as follows:

UR.1.2. Conveyor Installation

⋮

- (d) **Take-up Device.** – ~~If the belt length is such that a take-up device is required, this device shall be of the counter weighted type for either vertical or horizontal travel. Any take-up device shall provide constant and consistent tension for the belt under all operating conditions.~~

(Amended 2014)

Note: No changes are proposed for other subparagraphs under UR.1.2.

Background/Discussion:

During discussions at the 2012 and 2013 meetings of the USNWG on Belt-Conveyor Scales, the WG recognized that there are take-up devices in use on belt-conveyor scale systems that operate favorably that are constructed according to designs other than the “counter weighted” type. One example is a take-up device that is reportedly capable of producing acceptable results and operates by incorporating a hydraulic-operated belt tension adjustment mechanism that responds to input from a load cell, which actively monitors belt tension. The USNWG agrees that the existing requirement of a “counter weighted” type of belt tension device is excessively prescriptive and the work group does not consider it appropriate to mandate design criteria for belt-conveyor systems in the NIST Handbook 44 Belt-Conveyor Scale Systems Code.

Furthermore, the existing language in NIST Handbook 44, (2.21.) paragraph UR.1.2.(d) does not explicitly require the use of a gravity-type (or counter-weighted) tension device unless the conveyor is of sufficient length that a take-up device is needed. The phrase “of sufficient length” does not provide clearly defined parameters regarding belt length in this existing requirement. Thus, the need for a belt tension device is open to interpretation by enforcement officials and the lack of specificity is believed to detract from the uniform application of the requirement. The current language also implies that relatively shorter conveyors may not need any type of belt tensioning device and the validity of that notion is being questioned by some USNWG members.

NCWM 2014 Interim Meeting: Mr. Bill Ripka (Thermo Fisher Scientific), Chair of the USNWG on BCS, spoke on behalf of Thermo Fisher Scientific and the USNWG on BCS in support of the proposal. Mr. Ripka indicated that the views of the USNWG are clear and based on a belief that NIST Handbook 44 is a set of criteria and not intended to be a design manual. There are many ways of addressing belt tension in the marketplace today. To be able to

increase belt speed, some other form of belt tensioning device is needed because a counter weight take-up device can't accommodate higher speeds. NIST Handbook 44 should not prevent technology from moving forward.

The Committee also heard comments from the SMA in support of the item as written, providing the rationale that a specification should not mandate product design.

Hearing no opposition and only comments in support of the proposed changes to UR.1.2. Conveyor Installation, the Committee agreed to recommend the item as shown above in the "Item Under Consideration" for a vote.

2014 NCWM Annual Meeting: The SMA supported the item as written, reiterating comments provided during the 2014 NCWM Interim Meeting.

NIST, OWM provided the following comments with respect to this item:

- The proposed changes will remove prescriptive language that permits only the use of a certain type of device to maintain tension on a conveyor belt that complies with specific design criteria.
- This requirement as it currently exists allows only the type of "take-up" device that utilizes a counter weight and the force of gravity in order to maintain belt tension.
- NIST, OWM expects that replacing this wording with the proposed language result in manufacturers of belt-conveyor scale weighing systems having greater flexibility in the design criteria for their equipment.
- Based on manufacturers and other experts, NIST, OWM understands that alternative designs for devices that provide conveyor belt tension are available and will perform satisfactorily while established criteria for belt-conveyor scale performance are maintained.
- Some types of systems may perform within acceptable limits without the use of a take-up device.
- NIST, OWM expects that the proposed changes will eliminate the need for field inspectors to make a subjective determination whether the length of conveyor belt warrants the use of a take-up device.
- The need for a take-up device will be determined by the system's ability to meet performance requirements.

The Committee heard comments in support of the proposal. Hearing no comments in opposition, the Committee agreed to recommend the item be presented for vote as shown in Item Under Consideration.

At their 2013 Interim Meeting, CWMA recommended the item be forwarded to the NCWM as an Informational Item due to lack of information about available belt tensioning devices and their effect on metrological integrity. In 2014, CWMA reported it believed the item has been sufficiently developed and recommended it move forward as a Voting item.

WWMA heard support and no opposition to the proposal and agreed the current language is open to interpretation during their fall 2013 meeting. The proposed language provides clear, definitive parameters for the take-up device that don't mandate design criteria. WWMA forwarded the item to NCWM, recommending it as a Voting Item.

NEWMA defers to the Work Group and other jurisdictions with more knowledge of these devices. During their 2013 Interim Meeting and 2014 Annual Meeting, NEWMA forwarded the item to NCWM recommending it as a Voting Item.

During their fall 2013 meeting, SWMA received some comments and discussion on providing clarity of the terms "constant" and "consistent" However, based on a recommendation from the Work Group, the SWMA agreed to forward the item to the NCWM S&T Committee for consideration.

330 LIQUID MEASURING DEVICES

330-1 VC S.1.6.7. and S.1.6.8. Recorded Representations and UR.3.3. Computing Device

(This item was Adopted.)

Source:

Liquid Controls (2014)

Purpose:

Address the issue of receipt (printed, electronic, and optional).

Item Under Consideration:

Amend NIST Handbook 44 Liquid Measuring Devices Code as follows:

S.1.6.7. Recorded Representations. – Except for fleet sales and other price contract sales and for transactions where a post-delivery discount is provided, a printed receipt providing the following information shall be available through a built-in or separate recording element for all transactions conducted with point-of-sale systems or devices activated by debit cards, credit cards, and/or cash:

- (a) the total volume of the delivery;
- (b) the unit price;
- (c) the total computed price; and
- (d) the product identity by name, symbol, abbreviation, or code number.

~~For systems equipped with the capability to issue an electronic receipt, the customer may be given the option to receive the receipt electronically (e.g., via cell phone, computer, etc.)~~

[Nonretroactive as of January 1, 1986]

(Added 1985) (Amended 1997, ~~and 2012,~~ and 2014)

and,

S.1.6.8. Recorded Representations for Transactions Where a Post-Delivery Discount(s) is

Provided. – Except for fleet sales and other price contract sales, a printed receipt providing the following information shall be available through a built-in or separate recording element that is part of the system for transactions involving a post-delivery discount:

- (a) the product identity by name, symbol, abbreviation, or code number;
- (b) transaction information as shown on the dispenser at the end of the delivery and prior to any post-delivery discount(s), including the:
 - (1) total volume of the delivery;
 - (2) unit price; and
 - (3) total computed price of the fuel sale.
- (c) an itemization of the post-delivery discounts to the unit price; and
- (d) the final total price of the fuel sale after all post-delivery discounts are applied.

~~For systems equipped with the capability to issue an electronic receipt, the customer may be given the option to receive the receipt electronically (e.g., via cell phone, computer, etc.).~~

(Added 2012) (Amended 2014)

and,

UR.3.3. Computing Device. – Any computing device used in an application where a product or grade is offered for sale at one or more unit prices shall be used only for sales for which the device computes and displays the sales price for the selected transaction.

(Became retroactive in 1999)

(Added 1989) (Amended 1992)

The following exceptions apply:

- (a) Fleet sales and other price contract sales are exempt from this requirement.
- (b) A truck stop dispenser used exclusively for refueling trucks is exempt from this requirement provided that:
 - (1) all purchases of fuel are accompanied by a printed receipt of the transaction containing the applicable price per gallon, the total gallons delivered, and the total price of the sale; and
(Added 1993)
 - (2) unless a dispenser complies with S.1.6.4.1. Display of Unit Price, the price posted on the dispenser and the price at which the dispenser is set to compute shall be the highest price for any transaction which may be conducted.
(Added 1993)
- (c) A dispenser used in an application where a price per unit discount is offered following the delivery is exempt from this requirement, provided the following conditions are satisfied:
 - (1) the unit price posted on the dispenser and the unit price at which the dispenser is set to compute shall be the highest unit price for any transaction;
 - (2) all purchases of fuel are accompanied by a printed receipt recorded by the system for the transaction containing:
 - a. the product identity by name, symbol, abbreviation, or code number;
 - b. transaction information as shown on the dispenser at the end of the delivery and prior to any post-delivery discount including the:
 1. total volume of the delivery;
 2. unit price; and
 3. total computed price of the fuel sale prior to post-delivery discounts being applied.
 - c. an itemization of the post-delivery discounts to the unit price; and
 - d. the final total price of the fuel sale.

~~For systems equipped with the capability to issue an electronic receipt, the customer may be given the option to receive the receipt electronically (e.g., via cell phone, computer, etc.)~~

(Added 2012 and 2014)

(Added 1998) (Amended 1992, 1993, ~~and-2012, and 2014~~)

Background/Discussion:

The concept of electronic receipts is already incorporated in certain provisions of NIST Handbook 44 Liquid Measuring Device Code. Similar provisions are needed in other codes of NIST Handbook 44. At the 2013 NCWM Annual Meeting, members expressed support for including requirements to address the use of electronic receipts in the General Code rather than in individual device codes. Including requirements in the General Code would eliminate confusion and inconsistency, consolidate provisions from individual codes, and confine future updates to a single code. Item 310-2 on the Committee's agenda includes a proposal to address this issue in the General Code.

Item (330-1) is included as a companion item to Item 310-2 and proposes to change the LMD Code as follows:

- If a receipt is required, allow the customer to decline the option to receive any type of receipt.
- Add an option of electronic receipt as long as the system can generate electronic receipts.
- If a receipt is desired, allow the customer to select between printed and electronic receipt; or both.
- Remove references to electronic receipts from Liquid Measuring Device Code as they will be redundant.

Some concerns have been raised that this could lead to elimination of printed receipts, particularly for customers who have limited access to internet, smart phone, etc. However, the proposal is written to ensure that the printed receipt remain an option for the customer.

See Items 310-2 and 330-5 for related background and discussions.

NCWM 2014 Interim Meeting: NIST, OWM noted in its comments to the S&T Committee that this agenda item is intended as a companion to Agenda Item 310-2. If Item 310-2 is adopted, the proposed struck-out portions of this item (330-1) could be eliminated and consumers would continue to be provided the same privileges with respect to receiving hard-copy or electronic receipts for their transactions. If Item 310-2 is not adopted, it would be inappropriate to delete the sentences as shown in this item.

NIST, OWM also noted should the Committee decide to advance Items 310-2 and 330-1, the Committee should give consideration to consolidating them into a single item for NCWM action. See also Items 331-1 LPG Code Modifications (UR.2.8.) and 332-2 (S.1.5.3. Recorded Representations, Point-of-Sale Systems, LPG Code) that may be impacted by action on 310-2 and 330-1.

The Committee heard comments in support of the proposed changes to paragraphs S.1.6.7. and S.1.6.8. in comments it received for Item 310-2, which it considers a companion item. Hearing no opposition to the proposed changes, the Committee recommended the item for a Vote. The Committee acknowledged that this item is a companion to Item 310-2, and agreed should the changes to paragraph G-S.5.6. Recorded Representations proposed in Item 310-2 fail to be adopted; the statement that refers to electronic receipts in each of the three proposed paragraphs under this item shown struck out should remain. Thus, if Item 310-2 fails to be adopted, the Committee planned to amend the status of this item at the NCWM Annual Meeting and may not offer it for a Vote.

Annual 2014 Meeting: The Committee heard comments in support of the proposal. Ms. Juana Williams (NIST, OWM) reiterated NIST, OWM's comments from the 2014 Interim Meeting. Mr. Tim Chesser (Arkansas) raised a question about NIST, OWM's proposed handling of the companion items, and Ms. Tina Butcher (NIST, OWM) clarified this aspect of the comments. Mr. Gordon Johnson (Gilbarco) indicated support for the proposal provided Item 310-2 is adopted and agreed with NIST, OWM's comments from the Interim Meeting. Hearing no comments in opposition, the Committee agreed this item remain Voting.

Regional Association Comments:

At its 2013 Interim Meeting and 2014 Annual Meeting, the CWMA supported this item and forwarded it to NCWM recommending it as a Voting Item. At its May 2014 meeting, CWMA reported the item was sufficiently developed, and it should move to Voting status unless Item 310-2 is adopted. If Item 310-2 is adopted, the CWMA supports the Withdrawal of this item. NEWMA supported this item at its 2014 Annual Meeting and reported that they believed this new technology is associated with many of the device codes and agreed that acknowledging it in the General Code simplifies the use and updating of the handbook.

330-2 W S.1.6.7. Recorded Representations

(This item was Withdrawn.)

Source:

Illinois Department of Agriculture (2014)

Purpose:

To reduce confusion among the public.

Item Under Consideration:

Amend NIST Handbook 44 Liquid-Measuring Devices Code as follows:

***S.1.6.7. Recorded Representations.** – Except for fleet sales and other price contract sales and for transactions where a post-delivery discount is provided, a printed receipt providing the following information shall be available through a built-in or separate recording element for all transactions conducted with point-of-sale systems or devices activated by debit cards, credit cards, and/or cash:*

- (a) the total volume of the delivery;*
- (b) the unit price;*
- (c) the total computed price; and*
- (d) the product identity **matching the identity on the dispenser** by name, symbol, abbreviation, or ~~code~~ **octane** number.*

[Nonretroactive January 1,1986]

(Added 1985) (Amended 1987, 1988, ~~and~~ **2012, and 20XX**)

Background/Discussion:

The LMD Code currently allows businesses to identify the product being sold on the receipt in a misleading way. For example, many stores in a certain chain have fuel that is labeled “Regular” on the dispenser, but their receipt identifies the product as “BLUE.” If a store has Regular 87 octane fuel for \$3.699 and Silver 89 octane fuel for \$3.599, the customer may select the Regular by mistake based on its lower octane rating and name. If the receipt simply identifies the product as “BLUE,” the consumer may not know if they were charged the wrong unit price or if they chose the wrong pump by their own mistake (the Regular nozzle is green).

In another example, a verbal complaint was made to a Weights and Measures Inspector that the receipt was not clear. This customer worked for a company that would reimburse the fuel cost as long as it was “Regular” fuel that was purchased. This customer went to a station and purchased “Regular” fuel, however the receipt had the identity as “Unleaded.” This person was not reimbursed because most gas is unleaded, and, thus, the identification of the product as only “Unleaded” does not mean it was “Regular” gas. Adding the phrase “matching the identity on the dispenser” to the requirement makes it clear to the businesses that the product identity on the receipt must agree with the product identity statement on the dispenser. For the same reason, the word “code” should be changed to “octane.” A “code” number could be any number and may confuse consumers when it comes to which product they

purchased; however, the “octane” number on the receipt will be understandable to the customer since it matches the octane number displayed on the dispenser.

NCWM 2014 Interim Meeting: There were multiple comments questioning how the proposed language would apply. Of particular concern was how the reference to “matching” would be interpreted and applied.

The Committee heard from Ms. Juana Williams (NIST, OWM) who noted that the provision allowing the use of codes was included at the time the paragraph was added in 1985 to recognize that some systems, both weighing and measuring had limited character capabilities. Mr. Bill Hornbach (Chevron) and Mr. Gordon Johnson (Gilbarco) commented that some systems still have limited character sets and may need to use abbreviations. While the language recognizes the use of “abbreviations,” this seems to conflict with the reference to “matching” identity. The Committee heard several suggestions for alternate language, including a suggestion for replacing the term “matching” with “corresponding.” However, there wasn’t strong support for any specific alternative. Ms. Kristin Macey (California) and Ms. Williams provided suggestions for alternative modifications to the language that might address some of the comments provided.

The Committee heard several comments suggesting that this issue would be better addressed as a User Requirement. The Committee agreed that, while paragraph S.1.6.7. is necessary to specify what information the device must be able to print on the receipt, it is the user’s responsibility to maintain this information correctly and to enter accurate identity statements.

The Committee also heard multiple comments indicating that the current language in paragraph S.1.6.7. is adequate to address the scenario outlined in the proposal. If the identity of the product on the receipt is different from that on the dispenser, then the receipt is not correctly recording the identity of the product and the device is not being maintained in compliance with paragraph S.1.6.7.

Based on the lack of support and the questions raised regarding the specific language in the proposal, the Committee decided to Withdraw this item. If the submitter wishes to pursue the item further, the Committee recommends that the submitter consider proposing a User Requirement as an alternative proposal.

Regional Association Comments:

At its 2013 Interim Meeting, the CWMA supported this item and forwarded it to NCWM, recommending that it be a Voting Item.

At its 2013 Annual Meeting, the SWMA received comments from industry and government officials concerned with the intent of the item. The language of the proposed item does not make intent clear. SWMA did not forward this item to NCWM.

330-3 VC N.4.2.4. Wholesale Devices

(This item was Adopted.)

Source:

Flint Hills Resources (2013)

Purpose:

To better align wholesale meter testing with current testing procedures, measuring practices and technology changes while maintaining the integrity of the special test.

Item Under Consideration:

Amend paragraph N.4.2.4. as follows:

N.4.2.4. Wholesale Devices. – “Special” tests shall be made to develop the operating characteristics of a measuring system and any special associated or attached elements and accessories. “Special” tests shall include a test at **or slightly above** the slower of the following rates:

- (a) 20 % of the marked maximum discharge rate; or
- (b) the minimum discharge rate marked on the device.

In no case shall the test be performed at a flow rate less than the minimum discharge rate marked on the device.

(Amended 2014)

Background/Discussion:

The Committee originally received a proposal from the submitter that was intended to clarify that conducting a slow flow test to the marked minimum discharge rate is required for type evaluation and testing to the minimum discharge flow rate developed under the conditions of installation for routine field inspections is appropriate. (See the Committee’s 2013 Final Report for details.) The original proposal would:

1. Remove the rigidity of the current language and provide for flexibility and efficiency while maintaining the requirement to test at different flow rates to determine the accuracy of a measuring system;
2. Differentiate between testing for type evaluation and field verification;
3. Reflect changes in field testing procedures, technology, and industry practices; and
4. Improve meter performance by establishing a meter factor for the slowest preset flow rate.

The submitter noted that the current language in NIST Handbook 44 is very rigid and does not take field installation conditions into consideration. It may not be possible or practicable to achieve the marked minimum discharge rate during field tests without changes to upstream equipment (valves, pumps, etc.), changing the flow computer programmed presets, or changing the idling of other fueling bays during testing.

The code does not allow for any deviation from the “shall” test at the marked minimum discharge rate. Current loading rack systems generally do not have a discharge nozzle or other physical means downstream of the meter to control or restrict the flow rate. Today, most rely on pumps and valves upstream of the meter and preprogrammed flow rates for specific products with an assigned meter factor for each flow rate and product. The proposed change would still have allowed for testing at the marked minimum discharge rate when there is a discharge nozzle or other physical means in use downstream of the meter to restrict flow, but would have recognized the need to vary from the marked minimum discharge rate for systems not so equipped.

The submitter notes that it is more productive to verify that the system is operating properly when used in its intended manner and set-up rather than alter the system for test-purposes and then return it to its “as-used condition.” Adjusting the system to flow at the marked minimum discharge rate by making changes to the system when that flow rate is not used introduces variables into the system not normally seen and adds little to no value.

Even if the system can achieve the marked minimum discharge rate (for example, through the use of a discharge nozzle), it is not always practical or possible to hit it exactly when testing. The variables involved with proving while multiple bays are operating at a loading rack can make achieving the target flow rate difficult. It is not really necessary to test exactly at the marked minimum flow rate to develop the operating characteristics of a meter. However, NIST Handbook 44 offers no room for deviation. Today, a wholesale meter tested “near,” but not exactly “at,” the marked minimum discharge rate is not being tested in accordance with the requirements of NIST Handbook 44. This problem may never be an issue, but it might (the history regarding the change to NIST

Handbook 44 Introduction section illustrates why the language in the handbook must match the application of it in the field). Amending the current language as proposed will remove this risk, however, slight.

In the LMD Code, retail motor-fuel devices with a marked minimum flow rate are tested “at or near the marked minimum flow rate,” but are not required to be tested at exactly the marked minimum. The proposal would make testing more uniform and consistent among different, but similar device types.

During the 2013 NCWM Interim and Annual Meetings, the Committee considered a number of alternative proposals to amend paragraph N.4.2.4. Wholesale Devices, including proposals that would have had the effect of making the “Special” test optional during field evaluation, or eliminating the “Special” test entirely for field evaluation. Much of the discussion that took place during the Committee’s Open Hearings relative to these proposals focused on two main issues:

1. Whether or not it’s still necessary, given advances in today’s meter technology, to conduct a “Special” test on a wholesale meter during field evaluation; and
2. Whether the conditions for conducting the “Special” test specified in paragraph N.4.2.4.(a) and (b) should be eliminated and language added to the paragraph that would require the test be performed at or near the minimum flow rate developed under the conditions of installation.

The Committee also heard and considered a number of key points during its 2013 Annual Meeting Open Hearings relative to these issues.

Refer to the Committee’s 2013 Final Report for additional background information and to view the different proposals that have been submitted relative to this item and a complete summary of the comments heard during the Open Hearings relative to those proposals.

NCWM 2014 Interim Meeting: NIST, OWM questioned whether or not the proposed changes in the most recent version of the proposal are appropriate and is concerned that the language may hamper officials and service personnel from conducting adequate tests. NIST, OWM reiterated the need to conduct a “Special” test at a flow rate appreciably slower than that of a “Normal” test, in order to best determine the condition of the meter. NIST, OWM provided some draft language as shown in Item Under Consideration to address Mr. Cotsoradis’ immediate concern of not being able to perform the “Special” test at exactly the flow rates specified in paragraph N.4.2.4. and noted that if this language were adopted there would be no reason to split the requirements for “Special” test into those that apply to type evaluation and those that apply to field evaluation.

The Committee also heard from the submitter of the proposal, Mr. Constantine Cotsoradis (Flint Hills Resources), who recognized in his comments not only the importance of conducting a slow flow test on a wholesale meter during both type evaluation and field evaluation; but also the need to maintain the current “Special” test criteria in NIST Handbook 44. Mr. Cotsoradis suggested that the community move slow on all of the issues that have been brought to light relating to his proposal. He stated that his primary concern and reason for submitting the proposal is that the current language in NIST Handbook 44 does not provide any flexibility concerning how the test is to be conducted and that it is not practical to conduct the test at exactly the flow rates specified by N.4.2.4. Wholesale Devices. He referenced the draft language that NIST, OWM had developed in their analysis of this item and had shared with him, which, if adopted, would allow the test to be performed “at or slightly above” the slower of the flow rates specified in the paragraph. He indicated that this language would provide the kind of flexibility that he’s seeking.

Ms. Julie Quinn (Minnesota), Mr. Randy Jennings (Tennessee), Mr. Henry Oppermann (Weights and Measures Consulting, LLC), and Mr. Rich Miller (FMC Technologies Measurement Solutions, Inc.) provided comments in support of Mr. Cotsoradis’ suggestion to amend the proposal to reflect NIST, OWM’s suggested alternative language in paragraph N.4.2.4. Wholesale Devices, thereby making it permissible to perform the “Special” test at or near the slower of the flow rates specified. Mr. Michael Keilty (Endress + Hauser Flowtec AG USA) noted that Canada requires a program that allows a test at normal and lower flow rates.

The Committee acknowledged the comments in support of maintaining the requirement for conducting “Special” tests during routine field inspections and agrees with the premise that the “Special” test needs to be conducted during both type evaluation and field evaluation. The Committee also acknowledged that it is not practical to conduct “Special” tests at exactly the flow rates specified in the current paragraph. Based on comments heard during the Open Hearings indicating that the key concern of the submitter and others is that the current language does not provide any flexibility with respect to the flow rates specified in the paragraph, the Committee agreed to modify the proposal to read as shown in the “Item Under Consideration.” The Committee believes that the item has been adequately reviewed and discussed and recommended that the item be designated as a “Voting” item.

NCWM 2014 Annual Meeting: The Committee heard comments from Ms. William (NIST, OWM) who commented that NIST, OWM believes the proposed changes would maintain the validity of the “Special Test” while providing additional flexibility being sought by the submitter. Mr. Cotsoradis noted that, while he believes the proposed language won’t change how meters are tested in the field, it will change the threshold so that it isn’t specifying the exact minimum flow rate. The Committee also heard comments from Mr. Dmitri Karimov (Liquid Controls) who noted that the phrase “slightly above” is a somewhat ambiguous term; he suggested the Committee might consider language used in Canadian documents which specifies a value of 10 % above the target value. In its deliberations, the Committee acknowledged that the phrase leaves room for interpretation; however, the Committee believes that the term is adequate and provides for flexibility; yet clarifies that drafts are not to be conducted at flow rates lower than the marked minimum. Hearing no other opposition to the proposal, the Committee agreed to present the proposal for a vote as shown in the “Item Under Consideration.”

Regional Association Comments:

At both its fall 2013 Interim Meeting and spring 2014 Annual Meeting, the CWMA agreed the item has been sufficiently developed and recommended that it be a Voting Item. The CWMA also reported there were no comments in opposition to the proposal.

At its fall 2013 meeting, WWMA acknowledged the developing nature of this issue and the factors associated with pumping systems that have an impact on the test result. The WWMA looks forward to hearing input from meter manufacturers and interested parties that have a stake in addressing special tests on wholesale devices. The WWMA also acknowledges the 1949 S&T Report that identifies “Special” tests are to be left to the judgment of the official. WWMA recommended that this item be an Informational Item.

At its fall 2013 meeting, NEWMA recommended keeping this item as Informational until the Measuring Sector has a chance to provide data. At its spring 2014 meeting, NEWMA supported moving the item forward for a Vote.

At its fall 2013 Annual Meeting, SWMA received comments suggesting some of the language regarding wholesale and retail could be better harmonized across different codes. Comments were also received expressing concerns about the wording in regards to operational parameters. Based on comments received, the SWMA recommended the item be further Developed.

There was one position from a “Government” member posted on NCWM’s 2014 Online Position Forum in support of the proposal.

330-4 D N.4.2.5. Initial Verification and UR.2.5.1. Initial Verification Proving Reports

Source:

Minnesota Weights and Measures Division (2014)

Purpose:

To update NIST Handbook 44 to reflect the technological changes in registers for liquid measuring devices and to alert weights and measures officials to the fact that error in start-up and shut-down delivery quantities can introduce linear errors in the calibration at normal flow rates; these errors increase the further the delivered quantity deviates from the prover size used at calibration.

Item Under Consideration:

Add the following new paragraphs to NIST Handbook 44, Section 3.30. Liquid-Measuring Devices Code:

N.4.2.5. Initial Verification. – A wholesale liquid measuring device shall be tested at all flow rates and with all products for which a calibration factor has been electronically programmed prior to placing it into commercial service for the first time or after being repaired or replaced.

A wholesale liquid measuring device not equipped with means to electronically program its flow rates and calibration factors shall be tested at a low and high flow rate with all products delivered prior to placing it into commercial service for the first time or after being repaired or replaced.

Example: A meter is electronically programmed to deliver regular and premium gasoline at a startup/shutdown flow rate of 150 gpm, a normal operating flow rate of 650 gpm, and a fall-back rate of 450 gpm. The meter is to be tested with regular gasoline at 150 gpm, 450 gpm, and 650 gpm; and with premium gasoline at 150 gpm, 450 gpm, and 650 gpm.

The official with statutory authority has the discretion to determine the flow rates and products at which a meter will be tested on subsequent verifications.

(Added 20XX)

UR.2.5.1. Initial Verification Proving Reports. – Initial verification proving reports for wholesale liquid measuring devices equipped with means to electronically program flow rates shall be attached to and sent with placed-in-service reports when the regulatory agency with statutory authority requires placed-in-service reports.

(Added 20XX)

Background/Discussion:

Wholesale metering systems are used to deliver product at many different flow rates. Many of these systems are equipped with features that allow different calibration factors to be programmed at those flow rates. Companies commonly set accuracy goals of $\pm 0.05\%$ at normal and “fallback” delivery rates; however, they are often reluctant to spend time entering different calibration factors for the initial (“start-up”) and ending (“shut-down”) portions of the delivery. Spending time calibrating the metering system at normal and fallback delivery rates to such a high degree of accuracy is wasted if the error introduced into the measurement by the start-up and shut-down quantities is unknown. An additional concern is that an unscrupulous operator could use the error introduced by the start-up and shut-down portions of the delivery (if known) to adjust calibration at the normal delivery rate such that the overall error of a typical delivery is predominantly in the user’s favor. Officials should be aware that when delivered quantities are greater than the prover used at calibration the start-up and shutdown errors have a counter-intuitive effect. Underregistration errors (which are normally in the consumers’ favor) in the start-up and shut-down portions of the delivery may actually create shortages in the total delivery if calibration of the normal rate is adjusted to compensate for that underregistration. While these errors should be well within tolerance if the start-up and shut-down errors are in tolerance, an official who is trying to determine predominance of error should be aware of this effect and know how to determine the expected error in a typical delivery. Operators need to understand the importance of knowing and accounting for the effects of start-up and shut-down errors. Officials need to be aware of the potential for misusing that knowledge. Terminals and refineries want to maximize the accuracy of their liquid measuring devices by optimizing the calibration factors at typical delivery rates.

This proposal is not intended to have any effect on locations that do not use electronic calibration factors to optimize accuracy at every delivery rate. Even at locations which do use multiple calibration factors, no action is required unless the official notices that the error for the start-up and shut-down rates is predominantly in one direction. If the start-up and shut-down errors are predominantly in one direction, the official then needs to determine the size of a typical transaction and the likely predominance of the error. Device owners can easily ensure that they have no problems with this requirement by making sure their devices are in tolerance at slow flow start-up and shut-down rates, and the errors are not predominantly in one direction.

See Appendix C, *How Slow Flow Accuracy Affects LMDs*.

2014 NCWM Interim Meeting: The Committee considered a proposal from the submitter to add a new paragraph to the NIST Handbook 44 Liquid Measuring Devices Code as follows:

N.4.2.5. Determination of Error on Wholesale Devices with Multiple Flow Rates and Calibration Factors – On wholesale devices which are configured with multiple flow rates where each flow rate has its own calibration factor, and which are programmed to deliver a set quantity at a slow flow rate on start-up and/or shut-down, the effect of start-up and shut-down rates on the accuracy of the typical delivery shall be considered if the typical delivery is greater or less than the test measure used at the time of evaluation. The weights and measures jurisdiction shall determine the size of the typical delivery based upon available evidence.

The Committee acknowledged that, at the heart of this issue is the need to develop guidance for inspectors and service personnel in the proper use and inspection of systems with multiple calibration factors. This work may encompass issues such as how the multiple calibration factor features can be used to adjust meters at different flow rates; to adjust the accuracy of the initial “start-up” and ending “slow-down” portions of a delivery; to adjust the accuracy of a meter when delivering different product types, etc.

During its Open Hearings, the Committee heard questions from Mr. Henry Oppermann (Weights and Measures Consulting) and from Ms. Tina Butcher (NIST, OWM) who questioned how an inspector would analyze the results without conducting accuracy tests at the slower flow rates. Ms. Julie Quinn (Minnesota), the submitter of this proposal, clarified that in order to apply the proposed “Note,” an inspector must run tests at these flow rates to be able to determine the magnitude and direction of the error. Ms. Williams raised some additional questions and noted some comments from NIST, OWM (extracted from NIST, OWM’s analysis provided to the S&T Committee), including the following.

- How is an inspector to assess the “start-up” and “slow-down” portions of the delivery given that they include quantities delivered at multiple different flow rates and the actual delivery sizes may vary?
- The minimum test draft size requirements may need to be considered and possibly revised to address tests of these systems.
- Caution should be used before making any sort of assessment without conducting any “slow flow” testing as outlined in the example (which assumes that no “slow flow” test was conducted).
- Percentage-based tolerances account and allow for different errors at different delivery sizes.
- If the concern centers on the “start-up” and “slow-down” portions of the delivery, the proposal may need to provide more specific guidance in this regard.

Mr. Constantine Cotsoradis (Flint Hills Resources) recognized the validity of the issue and expressed support for proposals that recognize changing technology, but he also acknowledged the questions that were raised within the regionals and at the Interim Meeting needing to be addressed.

Ms. Quinn clarified the purpose of the item and the circumstances leading to the proposal, noting that she was unable to attend other regional meetings to provide further explanations of this proposal. She noted that, at one time, the amount of product and the flow rate for the start-up and shut-down portions of a delivery were manually controlled. Today’s systems tend to use automated, programmed values for these portions of the delivery. Ms. Quinn noted that, frequently, companies are reluctant to spend additional time validating the calibration factors used in the start-up and shut-down portions of the delivery. The “typical delivery” sizes would be determined from examining records at the terminal. The intent of the proposal is to raise awareness of the need for the inspector to consider the effects of these portions of the delivery on its overall accuracy.

After hearing comments during the Open Hearings and discussing the item further in its work sessions, the Committee agreed to designate this as a Developing Item. The Committee believes, at least initially, work needs to be focused on the development of guidelines and test procedures that could be incorporated into examination

procedure outlines. Ms. Quinn agreed to serve as the contact point for the item. The Committee asks that others interested in this work contact Ms. Quinn. The Committee looks forward to updates on this work as it progresses.

Annual 2014 Meeting: The Committee heard comments from Ms. Juana Williams (NIST, OWM) who stated that, like the S&T Committee, NIST, OWM believes that the existing language in the Liquid-Measuring Devices Code allows for any additional testing that is within the usual and customary use of the system and that develops the operating characteristics of that system, and also believes the work should focus on the development of guidelines and test procedures. NIST, OWM looks forward to continued collaboration with the group developing this issue.

The Committee also heard an update from Ms. Quinn, the submitter of this item. Ms. Quinn reported that a group of interested parties has been collaborating on this issue since January 2014. During the NCWM Annual Meeting, this group met and developed suggested language to address the concerns outlined in this item. Ms. Quinn asked that the Committee include the suggested language in this item for further review and comments by the regional associations and others in the fall. The Committee agreed to maintain this item on its agenda to allow for additional development and input as requested by Ms. Quinn and to replace the original recommendation with the revised language provided by Ms. Quinn as shown in the “Item Under Consideration” above along with a change to the title to reflect the revised paragraph number.

Regional Association Comments:

CWMA 2013 Interim Meeting: CWMA believed this item was ready and forwarded it to NCWM, recommending it as a Voting Item. At its 2014 Annual Meeting, the CWMA supported continued development of the item.

WWMA 2013 Annual Meeting: The WWMA did not forward this item to NCWM, because the language is vague and offers no clear solution.

NEWMA 2013 Interim Meeting: NEWMA did not believe this item is necessary and would not dramatically impact the test results of the meters. NEWMA did not forward the item to NCWM. At its 2014 Annual Meeting, NEWMA recommended this item be Withdrawn for lack of merit because the handbook already establishes a tolerance that applies to the full device test from start up to shut down and applying a tolerance to just start up or shut down could have a significant effect on test results.

The SWMA received comments in Open Hearings, and the SWMA S&T Committee’s Work Session indicating a strong concern with the wording “typical delivery.” The SWMA recommended the item be Withdrawn based upon lack of merit. The SWMA did not forward this item to NCWM.

330-5A VC UR.3.3. Computing Device.

(This item was Adopted.)

Item 330-5 was separated into two parts 330-5A and 330-5B during the 2014 Interim Meeting to facilitate review of the issues involved.

Source:

NCWM Task Group (TG) on Retail Motor Fuel Dispenser Price Posting and Computing Capability (2013)

Purpose:

Refine the criteria in the LMD Code related to price posting and computing capability of RMFDs for post-delivery discounted transactions to more clearly reflect the recommendations of the NCWM Task Group on RMFD Price Posting and Computing Capability for the indication of the highest unit price.

Item Under Consideration:

Amend paragraph UR.3.3.(c)(1) by adding underlined text as follows:

UR.3.3. Computing Device. – Any computing device used in an application where a product or grade is offered for sale at one or more unit prices shall be used only for sales for which the device computes and displays the sales price for the selected transaction.

(Added 1989) (Amended 1992)

The following exceptions apply:

- (a) Fleet sales and other price contract sales are exempt from this requirement.
- (b) A truck stop dispenser used exclusively for refueling trucks is exempt from this requirement provided that:
 - (1) all purchases of fuel are accompanied by a printed receipt of the transaction containing the applicable price per gallon, the total gallons delivered, and the total price of the sale; and
(Added 1993)
 - (2) unless a dispenser complies with S.1.6.4.1. Display of Unit Price, the price posted on the dispenser and the price at which the dispenser is set to compute shall be the highest price for any transaction which may be conducted.
(Added 1993)
- (c) A dispenser used in an application where a price per unit discount is offered following the delivery is exempt from this requirement, provided the following conditions are satisfied:
 - (1) the unit price posted on the dispenser and the unit price at which the dispenser is set to compute **prior to the application of any discount** shall be the highest unit price for any transaction;
 - (2) all purchases of fuel are accompanied by a printed receipt recorded by the system for the transaction containing:
 - a. the product identity by name, symbol, abbreviation, or code number;
 - b. transaction information as shown on the dispenser at the end of the delivery and prior to any post-delivery discount including the:
 - 1. total volume of the delivery;
 - 2. unit price; and
 - 3. total computed price of the fuel sale prior to post-delivery discounts being applied.
 - c. an itemization of the post-delivery discounts to the unit price; and
 - d. the final total price of the fuel sale.

For systems equipped with the capability to issue an electronic receipt, the customer may be given the option to receive the receipt electronically (e.g., via cell phone, computer, etc.)

(Added 2012)

(Added 1998) (Amended 1992, 1993, ~~and~~ 2012, and 2014)

Background/Discussion:

2013 NCWM Interim Meeting: The NCWM Task Group on RMFD Price Posting and Computing Capability met to review examples of receipts and scenarios for compliance with language adopted into NIST Handbook 44 in 2012 to address systems that are used to offer post-delivery discount pricing in retail motor-fuel dispensing applications.

During that review, the TG noted that the language in paragraph UR.3.3.(c)(1) could be incorrectly interpreted to prohibit the application of both pre- and post-delivery discounts in a single transaction; the TG developed proposed changes to the paragraph to address this concern. The current language in (c)(1) states that, in order to qualify for the exemptions offered for post-delivery discounts, the unit price posted on the dispenser and the unit price at which the dispenser is set to compute shall be the highest unit price for any transaction. In instances, where a customer elects to receive a discount prior to the delivery (i.e., a “pre-delivery” discount), this might create an unintended conflict. For example, if a customer elects to pay in cash at the start of the transaction, the dispenser might display and compute at a lower, cash unit price. Since UR.3.3.(c)(1) stipulates posting and computing at the highest unit price, some might interpret this to mean that this dispenser may not also participate in post-delivery discount pricing or be entitled to the exemptions in U.R.3.3.(c). The original intent of the changes proposed by the TG and adopted by the NCWM was not to restrict systems from participating in *both* pre- and post-delivery discounting. Consequently, the TG proposes changes as outlined in UR.3.3.(c)(1) in the “Item Under Consideration” above.

The TG also developed proposed changes to UR.3.3.(c)(2) to acknowledge that: (1) the system must be able to provide a receipt to the customer, but the customer can be given an option of receiving the receipt or not; and (2) an electronic receipt is an acceptable alternative to a hard copy receipt if the purchaser agrees to an electronic receipt in lieu of, or in addition to, a hard copy. The Task Group believes that, should a customer prefer not to receive a receipt or prefer to receive it electronically, this should be permissible. The proposed changes to UR.3.3.(c)(2) are shown Item 330-5B.

Lastly, the TG recommended changing the vertical alignment of the statement following UR.3.3.(c)(2) regarding the option of an electronic receipt so that it clearly applies to UR.3.3.(a), (b), and (c) rather than just part (c). As presently shown in NIST Handbook 44, this statement would apply only to UR.3.3.(c). The text shown in the “Item Under Consideration” above aligns that statement such that it would apply to UR.3.3.(a), (b), and (c).

The Committee agreed to add this item to its agenda to address these changes proposed by the TG. The Committee believes the proposed changes have merit and believe they simply clarify the original intent of the language developed by the TG and adopted by the NCWM. However, because the proposed changes were not available for publication and review in NCWM Publication 15, the Committee agreed that the item should be designated as an Informational Item to allow adequate opportunity for the review and comment by all stakeholders potentially affected by the proposed changes. The Committee also believes this will provide an opportunity for input on the specific language to ensure that it clearly and adequately addresses the concerns identified by the TG.

Two government representatives supported the proposed changes and one government representative indicated a neutral position on the item in the 2013 NCWM Online Position Forum.

Annual 2013 Meeting: The Committee heard comments from NIST, OWM suggesting that the proposed modifications to UR.3.3.(c)(2) are unnecessary given that the paragraph already includes the following statement permitting the use of electronic receipts:

For systems equipped with the capability to issue an electronic receipt, the customer may be given the option to receive the receipt electronically (e.g., via cell phone, computer, etc.).

Similar provisions are included in paragraphs S.1.6.7. Recorded Representations and S.1.6.8. Recorded Representations for Transactions Where a Post-Delivery Discount(s) is Provided. NIST, OWM also noted that the originally proposed UR.3.3.(c)(2) inadvertently required that the system be capable of providing an electronic receipt upon customer demand, regardless of whether or not the system was capable of providing one.

The Committee heard multiple comments in support of eliminating the proposed revisions to UR.3.3.(c)(2). The Committee also heard comments from multiple weights and measures jurisdictions expressing the need to retain the requirement for a hard copy receipt for those consumers who do not have access to an electronic version. Mr. Ross Andersen (New York, retired) noted the need to consider any requirements at the State level that apply to electronic records.

Comments received during the Open Hearings indicated that, in applications where receipts are required, the following principles should apply:

- A printed receipt must be made available to the customer.
- If a customer doesn't want a receipt, it is not necessary to provide one.
- The customer may be given the option of receiving an electronic receipt in lieu of a printed receipt.

The Committee also heard comments from both weights and measures jurisdictions and industry representatives suggesting that a provision be added to the General Code recognizing the acceptance of electronic receipts. Dr. Matthew Curran (Florida) commented that identifying and defining different types of discounts, such as "rebates," would be helpful for consumers as well as officials in understanding how these requirements apply.

2014 NCWM Interim Meeting: Ms. Fran Elson-Houston (Ohio) provided an update on behalf of the NCWM RMFD Price Posting and Computing Capability Task Group regarding the proposals outlined in Item 330-5. The changes proposed to paragraph UR.3.3. in Item 330-5 are to: (1) clarify the unit price posting requirements to ensure that RMFD systems are permitted to participate in both pre- and post-delivery discounts; and (2) clarify the requirements relative to electronic receipts.

Ms. Elson-Houston reported that the Task Group recognized that Item 310-2 on the S&T Committee's agenda proposes changes to G-S.5.6. Recorded Representations and those proposed changes, if adopted, would affect the Task Group's proposed changes to LMD Code Paragraph UR.3.3.(c)(2) with regard to the recognition of electronic receipts. The Task Group supports the proposed changes in Item 310-2 and, if those changes are adopted, would suggest eliminating corresponding references in LMD Code paragraph UR.3.3.(c)(2). The Task Group is amenable to linking action on Item 310-2 and proposed changes to UR.3.3.(c)(2); however, should there be complications in addressing the requirements relative to electronic receipts, the Task Group did not want the proposed changes to UR.3.3.(1) to be delayed.

Thus, the Task Group recommended splitting Item 330-5 into two parts; one part to address clarifications to unit price posting requirements and one part to address requirements relative to electronic receipts.

Hearing no comments in opposition to the proposal submitted by the Task Group, the S&T Committee agreed to separate the item into two parts. Item 330-5A proposes changes to UR.3.3.(c)(1) as shown in the "Item Under Consideration" above. Item 330-5B proposes changes to UR.3.3.(c)(2). The Committee agreed to designate both items as "Voting" items.

Annual Meeting: The Committee heard comments in support of this item. The Committee heard from Ms. Williams who commented the text proposed for addition to UR.3.3.(c)(1) is for clarification purposes only; that is, to clarify that the exemption is also intended to apply to dispensers in which the customer may select and set them to compute at a discounted unit price prior to delivery (e.g., dispensers equipped with a selectable cash/credit feature). The Committee also heard comments from Ms. Elson-Houston speaking as Chairman of the TG who agreed with NIST, OWM's comments and supports moving the item forward for Voting. Hearing no comments in opposition, the Committee agreed this item remain Voting.

Regional Association Comments:

CWMA 2013 Interim Meeting: The CWMA recommended the item remain as an "Information" item. At its 2014 Annual Meeting, the CWMA reported there was no opposition presented and stated the item has been sufficiently developed and supported moving the item forward as a Voting item.

The WWMA agrees with the proposed language change to UR.3.3.(c)(1). WWMA finds the proposed language in UR.3.3.(c)(2) is not clear and may be interpreted to allow a purchaser to demand an electronic receipt despite the capability of the device. WWMA agrees the existing language in UR.3.3.(c)(2) is adequate. WWMA recommended that this item be a Developing item.

NEWMA 2013 Interim Meeting: NEWMA recommended this item be designated as a Voting Item and commented that the proposed changes will help clarify the intent of the WG's original suggestion. At its 2014 Annual Meeting, NEWMA supported moving the item forward as a Voting item.

The SWMA did not receive any comments opposing the item. There were comments that the electronic receipt recommendation may also be suited to the General Code as well. The SWMA supported this item as written.

See previous Reports of the National Conference on Weights and Measures for additional history on this item.

330-5B VC UR.3.3. Computing Device.

(This item was Adopted.)

Source:

NCWM Task Group on Retail Motor Fuel Dispenser Price Posting and Computing Capability (2013)

Purpose:

Refine the criteria in the LMD Code related to price posting and computing capability of RMFDs for post-delivery discounted transactions to more clearly reflect the recommendations of the NCWM Task Group on RMFD Price Posting and Computing Capability for the indication of the highest unit price.

Item Under Consideration:

Amend paragraph UR.3.3.(c)(2) to recognize electronic receipts as follows:

- (c) A dispenser used in an application where a price per unit discount is offered following the delivery is exempt from this requirement, provided the following conditions are satisfied:
 - (1) the unit price posted on the dispenser and the unit price at which the dispenser is set to compute shall be the highest unit price for any transaction;
 - (2) all purchases of fuel are accompanied by a ~~printed~~ receipt recorded by the system. ~~for the transaction containing:~~ **The receipt shall contain:**
 - a. the product identity by name, symbol, abbreviation, or code number;
 - b. transaction information as shown on the dispenser at the end of the delivery and prior to any post-delivery discount including the:
 - 1. total volume of the delivery;
 - 2. unit price; and
 - 3. total computed price of the fuel sale prior to post-delivery discounts being applied.
 - c. an itemization of the post-delivery discounts to the unit price; and
 - d. the final total price of the fuel sale.

~~For systems equipped with the capability to issue an electronic receipt, the customer may be given the option to receive the receipt electronically (e.g., via cell phone, computer, etc.)~~

(Added 2012)

(Added 1998) (Amended 1992, 1993, ~~and 2012, and 2014~~)

Background/Discussion:

Based upon input from the RMFD Price Posting and Computing Capability Task Group, the Committee agreed during the 2014 NCWM Interim Meeting to separate Item 330-5 into two parts. Item 330-5A proposes changes to UR.3.3.(c)(1). Item 330-5B proposes changes to UR.3.3.(c)(2).

The Task Group offered two options for the Committee to consider with respect to proposed changes to paragraph UR.3.3.(c)(2); Option 1 was intended to apply if the Committee agreed not to recommend Item 310-2 for vote; Option 2 was intended to apply if the Committee agreed to recommend Item 310-2 for vote. Since the Committee agreed during the 2014 NCWM Interim Meeting to recommend Item 310-2 for vote, the Task Group's Option 2 is shown above in the "Item Under Consideration" for Item 330-5B. The Committee agreed to designate both items (330-5A and 330-5B) as "Voting" items. Refer to Item 330-5A for additional background information pertaining to this item.

The Committee acknowledged that Item 330-5B is a companion to Item 310-2. Should the changes to G-S.5.6. Recorded Representations proposed in Item 310-2 fail to be adopted, the Committee plans to amend Item 330-5B by retaining all the struck out portions of proposed paragraph UR.3.3.(c)(2) prior to vote or may withdraw Item 330-5B completely.

2014 Annual Meeting: The Committee heard comments in support of this item. Ms. Fran Elson-Houston (OH) speaking as Chairman of the TG acknowledged the need to strike the last line in this paragraph should Item 310-2 be adopted. Ms. Juana Williams (NIST, OWM) stated that NIST, OWM's comments for Agenda Item 330-1 also apply to this item. Additionally, NIST, OWM agrees with the Committee's plan to address this item based on action taken on Agenda Item 310-2. Hearing no comments in opposition, the Committee agreed this item remain Voting.

2014 Annual Meetings: Both the CWMA and NEWMA supported item moving the item forward as a Voting item.

See previous Reports of the National Conference on Weights and Measures for additional history on this item.

330-6 W UR.4. Maintenance Requirements

(This item was Withdrawn.)

Source:

Minnesota Weights and Measures Division (2014)

Purpose:

To clarify the application of G-UR.4.1. to liquid measuring devices at a single place of business.

Item Under Consideration:

Add a new User Requirement to the NIST Handbook 44 Liquid Measuring Devices Code as follows:

UR.4. Maintenance Requirements

UR.4.1. Maintenance of Equipment. – All liquid measuring devices in service and all mechanisms and devices attached thereto or used in connection therewith shall be maintained in proper operating condition throughout the period of such service. All liquid measuring devices in service at a single place of business shall be evaluated by product and grade. Equipment in service associated with a single product and grade at a single place of business which is found to be in error predominantly in

a direction favorable to the device user shall not be considered “maintained in a proper operating condition.”

Background/Discussion:

This proposal is meant to limit the opportunity to use tolerances as a way to gain advantage for the user over the consumer. Without this clarification, General Code paragraph G-UR.4.1. might be interpreted to mean that locations would be in compliance if all the devices measuring product with the lowest sales were set to deliver with errors in tolerance in favor of the consumer, and an equal number of devices measuring product with the highest sales were set to delivery with errors in tolerance in favor of the device user. This proposal would not allow that practice. For example, a gas station could not set all their “premium” gas dispensers (for which sales are typically lower) to underregister within tolerance and all their “regular” gas dispenser (for which sales are typically higher) to overregister within tolerance. Instead, approximately half of each grade should be short within tolerance and an equal number long within tolerance.

2014 NCWM Interim Meeting: Ms. Julie Quinn (Minnesota), submitter of this item, explained that her jurisdiction is finding companies taking advantage of the applicable tolerances. She noted that Minnesota has been evaluating the results of inspections based on product and grade and believes there is benefit to other jurisdictions using the same approach. She also noted that paragraph G-UR.4.1. uses the phrase “all equipment” at the beginning of the paragraph, which may be interpreted to mean that the paragraph cannot be applied unless *all* equipment at a given location is found to be in favor of the business. Ms. Quinn acknowledged comments from NIST, OWM and others that previous proposals have been made to include more specific guidance in paragraph G-UR.4.1.; however, unlike those proposals, the current proposal isn’t intended to stipulate a formula or be overly specific, just to emphasize the need to evaluate by product and grade rather than look at *all* devices at a site.

The Committee heard multiple comments that this issue is better addressed in the General Code. Mr. Gordon Johnson (Gilbarco) commented that, while this is directed more to device owners, Gilbarco has been getting calls from their customers who are expressing concern about the application of requirements such as site averages. There are instances where the average error for a site is minus one cubic inch and the locations are being rejected; however, this is within the limits of readability and uncertainty using a test measure or prover. Mr. Johnson also expressed concern about the reference to the expectation that fifty percent of each grade should have plus errors and fifty percent should have minus errors. Mr. Ross Andersen (New York-retired) noted while he doesn’t disagree with the concept of evaluating by grade, caution needs to be exercised because of variability that can occur with influences of product viscosity and temperature over time. Even if a device were adjusted as close to zero as practical, one could see drift in the results as conditions varied.

The Committee also heard concerns from NIST, OWM that the language might limit jurisdictions from considering other factors that might indicate noncompliance with maintenance and adjustment requirements (for example, device location, full-serve vs. self-serve, etc.). NIST, OWM suggested, if the proposed language is to be considered further, it should be modified to allow more flexibility; NIST, OWM provided suggested modifications to the proposal. NIST, OWM also questioned whether or not specific guidance for analyzing results should be included in a User Requirement; a Notes paragraph might be more appropriate. While many of the factors discussed are appropriate for inspectors to consider in analyzing maintenance of equipment, device owners are required to adjust devices as close to zero as practical. The Committee also heard comments indicating that there may be other factors that affect test results that need to be considered in making an assessment of compliance with G-UR.4.1.

Based upon the general lack of support for adding a new requirement to the LMD Code, the Committee decided to withdraw this item from its agenda. After hearing an explanation from the submitter and others regarding the difficulties that have been encountered in applying General Code paragraph G-UR.4.1., the Committee believes that it might be more appropriate to consider modifications to the General Code to address the concerns and would encourage the submitter and others to consider pursuing this option as an alternative future proposal.

Those commenting on this item during the Open Hearings noted that their comments also applied to Item 331-2, which proposes a corresponding requirement be added to the Vehicle-Tank Meters Code.

Regional Association Comments:

CWMA 2013 Interim Meeting: CWMA supported the item and forwarded it to NCWM recommending it as a Voting Item because it provides specific guidance in the LMD Code and helps support G-UR.4.1.

WWMA 2013 Annual Meeting: WWMA did not forward this item to NCWM because there was no support. The WWMA believes the current language in G-UR.4.1. is adequate and provides jurisdictions the ability to make determinations for predominance of error.

NEWMA 2013 Interim Meeting: NEWMA forwarded the item to NCWM and recommended that it be a Developing Item and be assigned to the submitter for development.

SWMA 2013 Annual Meeting: SWMA heard several comments during Open Hearings and in the Committee Work Session in opposition to this item. The Committee recommended the item be withdrawn. The Committee believed this item has been sufficiently addressed in the General Code of NIST Handbook 44. SWMA did not forward this item to NCWM.

See previous Reports of the National Conference on Weights and Measures for additional history on this item.

330-7 D Part 3.30. Price Posting and Computing Capability and Requirements for a Retail Motor-Fuel Dispenser (RMFD)

Source:

NIST, OWM and the Regional Weights and Measures Associations (2008)

Purpose:

Review new criteria in the LMD Code related to price posting and computing capability of RMFDs and provide guidance on the application of these requirements.

Item Under Consideration:

The NCWM Task Group (TG) on RMFD Price Posting and Computing Capability developed specific proposals for modifying the LMD Code to address price posting and computing requirements for RMFDs. These proposals were adopted by the NCWM in 2012 and published in the 2013 NIST Handbook 44; they are being revisited at the request of the NCWM S&T Committee who has asked the Task Group (TG) to complete its review of sample receipts and provide guidance on applying the new criteria. This Item, 360-3, is being retained as a Developing Item pending any additional assignments that may be given by the Committee to the Task Group relative to the implementation of new code requirements that may be adopted. Comments or inquiries may be directed to NIST Technical Advisor, Ms. Juana Williams, at (301) 975-3989 or juana.williams@nist.gov.

Background/Discussion:

In the early 1990s, various sections of the LMD Code in NIST Handbook 44 were modified to address multi-tier pricing applications in instances where the same product is offered at different unit prices based on the method of payment (such as cash or credit) or other conditions of the sale. Since that time, marketing practices have evolved to include the addition of new practices, such as frequent shopper discounts and club member discounts. Numerous questions have been posed to NIST, OWM and weights and measures officials regarding the requirements for posting unit prices, calculation of total price, customer-operated controls, and other related topics, such as definitions for associated terminology. In 2010, the Committee established a task group to further develop this issue. The Task Group proposed a number of changes to the LMD Code to address these issues and those changes were adopted in July 2012.

Additional details on this item can be found in the Committee's 2008-2012 Final Reports.

NCWM 2013 Interim Meeting Open Hearing: The Committee heard a suggestion from Ms. Elson-Houston, speaking as Chair of the TG on RMFD Price Posting and Computing Capability on a TG proposal, to further modify paragraph UR.3.3. Computing Device. Ms. Elson-Houston reported that the TG had met and agreed: (1) to develop sample receipts for transactions where motor fuel pricing is discounted after the delivery; (2) the Chair would

provide input on the “Dos and Don’ts” for complying with the requirements that went into effect January 2013 for posting on “The Oil Express” web newsletter; and (3) to recommend additional amendments to paragraph UR.3.3., which were provided to the Committee. The Committee established a new “Informational” item (See Item 330-4 on the Committee’s 2014 Agenda) to address those modifications and agreed to retain Developing Item 360-3 while the TG continues work to develop guidelines and examples on how the changes made last year to the LMD Code will apply to receipts for post-delivery discounted transactions.

On the 2013 NCWM Online Position Forum, one Government representative indicated support for this item with no additional comments.

NCWM 2013 Annual Meeting: The Committee heard comments from Ms. Juana Williams (NIST, OWM) who emphasized the importance of continuing to develop guidelines and information to assist regulatory officials and industry in interpreting and applying requirements relative to pre- and post-delivery discounts. NIST, OWM is working on the development of guidelines and examples that could be included in NIST EPOs and training materials and has already received positive feedback from members of the Task Group on the examples developed thus far. This information may also be of use to NTEP in the further development of checklist criteria for inclusion in NCWM Publication 14. NIST, OWM will continue to develop this information and make it available in updates to EPOs and course materials and would appreciate additional input from the community.

Ms. Beth Treseder (API) indicated that API and others within industry would appreciate copies of acceptable receipts as they become available.

The Committee believes that additional work is needed to develop examples and information that will enable consistent and uniform application of the requirements adopted in 2012 and encourages NIST, OWM’s continued work on such examples. The Committee asks that the TG continue its work by developing and providing additional examples of acceptable receipts to assist regulatory officials and industry in interpreting and applying these requirements. The Committee believes that examples of receipts from deliveries that include both pre- and post-delivery discounts in a single transaction are needed.

NCWM 2014 Interim Meeting: Ms. Elson-Houston (Ohio) spoke as Chair of the RMFD Price Posting and Computing Capability TG regarding a meeting of the TG, which occurred at the 2014 Interim Meeting. Ms. Elson-Houston advised the Committee that she will work with NIST to develop additional examples of receipts to illustrate both compliant and non-compliant receipts that could be included in the NIST Examination Procedure Outlines (EPOs) for RMFDs. The examples will be vetted with the TG and TG members agreed to provide input on the examples. Ms. Elson-Houston indicated that the TG believes this task would complete its work, unless the Committee has additional tasks to assign. During the Open Hearings, Ms. Elson-Houston encouraged members working with the post-delivery discount requirements, who might encounter problems or issues with the language that has been adopted, to forward their concerns to a member of the TG.

The Committee expressed appreciation for the TG’s hard work. The Committee supports the development of examples that can be included in the NIST EPOs and recognized these as essential to help ensure consistent interpretation of the NIST Handbook 44 provisions and requirements for post-delivery discounts. The Committee agreed that, once completed, this last task completes the work of the TG. Barring any new issues between now and the NCWM Annual Meeting, this item will be dropped from the Committee’s agenda in July. The Committee acknowledged that should future issues arise regarding the provisions for post-delivery discounts, the Committee may need to request that the TG be resurrected or reconstituted.

Following the 2014 Interim Meeting, the Committee received an excerpt from the TG’s January 2014 Meeting Summary. At the TG’s January 2014 meeting, the TG indicated its willingness to provide input on receipt examples. Chairperson Elson-Houston agreed to work with NIST to develop additional examples of receipts to illustrate both compliant and non-compliant receipts that might be included in future versions of NIST EPOs and training materials. The examples will be vetted with the TG and TG members agreed to provide input on the examples. The TG believes this final task would complete its work, unless the S&T Committee has additional tasks to assign.

2014 Annual Meeting: The Committee heard comments from Ms. Elson-Houston (Ohio, Chair of the RMFD Price Posting and Computing Capability TG). Ms. Elson-Houston reported that Mr. Dick Suiter (Richard Suiter Consulting) will be providing training to the State of Ohio on this topic and that he would be willing to provide similar training regional association meetings. The Committee also heard comments from Ms. Juana Williams (NIST, OWM) who indicated that NIST, OWM continues to note the importance of further development of guidelines and examples to assist in the uniform interpreting and applying of requirements for post-delivery discounts. NIST, OWM reiterates the need for additional sample receipts. NIST, OWM plans to continue developing the information on the receipt template previously made available and include the information in EPOs and course materials are updated. NIST, OWM appreciates the willingness of members of the NCWM RMFD Price Posting TG to assist in the review and vetting of these examples.

The Committee heard no additional comments on this item. The Committee agreed that the work of the Task Group is completed, and plans to remove this item from its agenda following the 2014 Annual Meeting.

Regional Association Comments:

At its 2013 Interim Meeting and its 2014 Annual Meeting, the CWMA believes this item should remain as a Developing item until the request for clarification is received from the Work Group.

WWMA recommended that this item remain as a Developing item and looks forward to seeing specific receipt examples from the TG on RMFD Price Posting and Computing Capability.

At its 2013 Interim Meeting and 2014 Annual Meeting, NEWMA recommended this item remain as a Developing Item and looks forward to additional data from the TG, including examples of both compliant and non-compliant receipts.

The SWMA did not receive any comments on this item. However, the Committee continues to support the work of the Task Group and recommends the item continue to be further developed.

See previous Reports of the National Conference on Weights and Measures for additional history on this item.

331 VEHICLE-TANK METERS

331-1 D N.4.6. Initial Verification and UR.1.5. Initial Verification Proving Reports

Source:

Minnesota Weights and Measures Division (2014)

Purpose:

To update NIST Handbook 44 to reflect the technological changes in registers for vehicle-tank meters and to alert weights and measures officials to the fact that error in start-up and shut-down delivery quantities can introduce linear errors in the calibration at normal flow rates which increase the further the delivered quantity deviates from the prover size used at calibration.

Item Under Consideration:

Add the following new paragraphs to NIST Handbook 44, Section 3.31. Vehicle-Tank Meters Code:

N.4.6. Initial Verification. - A vehicle tank meter shall be tested at all flow rates and with all products for which a calibration factor has been electronically programmed prior to placing it into commercial service for the first time or after being repaired or replaced.

A vehicle tank meter not equipped with means to electronically program its flow rates and calibration factors shall be tested at a low and high flow rate with all products delivered prior to placing it into commercial service for the first time or after being repaired or replaced.

Example: A vehicle tank meter is electronically programmed to deliver regular and premium gasoline at a startup/shutdown flow rate of 20 gpm, a normal operating flow rate of 100 gpm, and an intermediate rate of 65 gpm. The meter is to be tested with regular gasoline at 20 gpm, 65 gpm and 100 gpm; and with premium gasoline at 20 gpm, 65 gpm and 100 gpm.

The official with statutory authority has the discretion to determine the flow rates and products at which a vehicle tank meter will be tested on subsequent verifications.

UR.1.5. Initial Verification Proving Reports. - Initial verification proving reports for vehicle tank meters equipped with means to electronically program flow rates shall be attached to and sent with placed-in-service reports when the regulatory agency with statutory authority requires placed-in-service reports.

Background/Discussion:

Many terminals and refineries want to maximize the accuracy of their liquid-measuring devices by optimizing the calibration factors at typical delivery speeds and some bulk delivery companies are beginning to utilize the capabilities of electronic registers with multiple calibration factors to optimize their accuracy at flow rates that are customarily used. Just like registers on wholesale liquid measuring devices, these meters can be configured for a standard initial “start-up” and ending “shut-down” quantity delivered at a slower speed than is used for the remainder of the delivery. Service agents are expected to calibrate devices as close to zero as possible, but spending time calibrating normal delivery rates to a high degree of accuracy is wasted if the error introduced into the measurement by the start-up and shut-down quantities is unknown. On the other hand, an unscrupulous operator could also use the known error introduced by the start-up and shut-down errors to calibrate the normal delivery rates so that all the errors on typical deliveries work predominantly in the user’s favor. Officials should be aware that when delivered quantities are greater than the prover used at calibration, start-up and shut-down errors have a counter-intuitive effect. Underregistration, which normally operates in the consumers’ favor, may actually create shortages in the total delivery if calibration of the normal rate was adjusted to compensate for that underregistration. While these errors should be well within tolerance if the start-up and shut-down error are in tolerance, an official who is trying to determine predominance of error should be aware of this effect and know how to calculate the expected error in a typical delivery. Operators need to understand the importance of knowing and accounting for the effects of start-up and shut-down errors. Officials need to be aware of the potential for misusing that knowledge.

This proposal has no effect on locations that do not use electronic calibration factors to optimize accuracy at every delivery rate. Even at locations which do, no action is required unless the official notices that the error for the start-up and shut-down rates is predominantly in one direction. If the start-up and shut-down errors are predominantly in one direction, the official then needs to determine the size of a typical transaction and the likely predominance of the error. Device owners can easily ensure that they have no problems with this requirement by making sure that their devices are in tolerance at the slower start-up and shut-down flow rates and errors are not predominantly one way or the other.

See Appendix D, *How Slow Flow Errors Affect VTMs*.

See comments Item 330-4 for details of comments from the 2014 NCWM Interim Meeting.

2014 NCWM Interim Meeting: The Committee considered a proposal from the submitter to amend NIST Handbook 44 Vehicle Tank Meter Code as follows:

N.4.2.1. Determination of Error on Vehicle-Tank Meters with Multiple Flow Rates and Calibration Factors – On vehicle tank meters which are configured with multiple flow rates where each flow rate has its own calibration factor, and which are programmed to deliver a set quantity at a slow flow rate on start-up and/or shut-down, the effect of start-up and shut-down rates on the accuracy of the typical delivery shall be considered if the typical delivery is greater or less than the test measure used at the time of evaluation. The weights and measures jurisdiction shall determine the size of the typical delivery based upon available evidence.

After hearing comments during the Open Hearings and discussing the item further in its work sessions, the Committee agreed to designate this as a Developing Item. The Committee believes, at least initially, work needs to focus on the development of guidelines and test procedures that could be incorporated into examination procedure outlines. The Committee Chairman noted that the submitter, Ms. Julie Quinn (Minnesota), agreed to serve as the contact point for the item, and will be working with others to further develop guidelines for systems with multiple-point calibration capability. Ms. Quinn thanked those who have offered to help and noted that, although the specific issue presented to the Committee dealt with predominance of errors in certain portions of the delivery, she agreed the issue is really dealing with metering systems with multiple-point calibration capability. The Committee asks that others interested in this work contact Ms. Quinn. The Committee looks forward to updates on this work as it progresses.

NCWM 2014 Annual Meeting: The Committee heard comments from Ms. Juana Williams (NIST, OWM) who commented that like the S&T Committee, NIST, OWM believes the existing language in the Vehicle-Tank Meters code allows for any additional testing that is within the usual and customary use of the system and that develops the operating characteristics of that system, and also believes the work should focus on the development of guidelines and test procedures. NIST, OWM looks forward to continued collaboration with the group developing this issue.

The Committee also heard an update from Ms. Quinn, the submitter of this item. Ms. Quinn reported that a group of interested parties has been collaborating on this issue since January 2014. During the NCWM Annual Meeting, this group met and developed suggested language to address the concerns outlined in this item. Ms. Quinn asked that the Committee include the suggested language in this item for further review and comments by the regional associations and others in the fall. The Committee agreed to maintain this item on its agenda to allow for additional development and input as requested by Ms. Quinn, and to replace the original recommendation with the revised language provided by her as shown in the “Item Under Consideration” above, along with a change to the title to reflect the revised paragraph number.

Regional Association Comments:

CWMA 2013 Interim Meeting: CWMA heard no opposition on this item and based on testimony received from the floor, believes it is ready for a vote. CWMA forwarded the item to NCWM, recommending it as a Voting item. At its 2014 Annual Meeting, CWMA supported continued development of this item.

WWMA 2013 Annual Meeting: WWMA agrees the proposed language is confusing and no support for this item was conveyed. The WWMA agrees the language in the proposal is vague and offers no clear solution. This item was not forward to NCWM.

NEWMA 2013 Interim Meeting: NEWMA found this item confusing and believes that it lacks merit to move forward. NEWMA did not forward the item to NCWM. At its 2014 Annual Meeting, NEWMA reported that they revisited their position on this item from their 2013 Interim Meeting. NEWMA recommended the item be withdrawn for lack of merit, noting that NIST Handbook 44 already establishes a tolerance that applies to the full device test from start up to shut down and applying a tolerance to just start up or shut down could have a significant effect on test results.

SWMA 2013 Annual Meeting: SWMA again heard comments concerning the wording “typical delivery.” Based on comments received in Open Hearings and the SWMA S&T Committee’s Work Session, the SWMA agreed to withdraw based on lack of merit. SWMA did not forward this item to NCWM.

331-2 W UR.3. Maintenance Requirements

(This item was Withdrawn.)

Source:

Minnesota Weights and Measures Division (2014)

Purpose:

To clarify the application of G-UR.4.1. to liquid measuring devices at a single place of business.

Item Under Consideration:

Add a new User Requirement to the NIST Handbook 44 Vehicle-Tank Meters Code as follows:

U.R.3. Maintenance Requirements.

UR.3.1. Maintenance of Equipment. – All vehicle-mounted measuring systems in service and all mechanisms and devices attached thereto or used in connection therewith shall be maintained in proper operating condition throughout the period of such service. All vehicle-mounted measuring systems in service at a single place of business shall be evaluated by product and grade. Equipment in service associated with a single product and grade at a single place of business which is found to be in error predominantly in a direction favorable to the device user shall not be considered “maintained in a proper operating condition.”

Background/Discussion:

This proposal is meant to limit the opportunity to use tolerances as a way to gain advantage for the user over the consumer. Without this clarification, paragraph G-UR.4.1. might be interpreted to mean that locations would be in compliance if all the devices measuring product with the lowest sales were in tolerance in favor of the consumer, and an equal number of devices measuring product with the highest sales were in tolerance in favor of the device user. This proposal would not allow that practice. For example, a bulk delivery service could not set all their diesel fuel long within tolerance and all their gasoline short within tolerance. Instead, approximately half of each grade should be short within tolerance and an equal number long within tolerance.

Although jurisdictions have not yet come to an agreement as to a mathematical formula for calculating predominance of error, there seems to be general agreement on the principle that tolerances should not be applied to allow most devices of one grade to be short and most of another grade to be long. Many jurisdictions are already applying this interpretation to their application of G-UR.4.1. If adopted, this proposal will promote uniformity by standardizing enforcement across jurisdictions.

2014 NCWM Interim Meeting: Ms. Julie Quinn (Minnesota), submitter of this item, noted that the rationale for this proposal is the same as for Item 330-6 on the Committee’s Agenda. During its review of Item 330-6, the Committee heard comments from others, who also stated that their comments applied to Items 330-6 and 331-2. See that item for comments and details.

The Committee heard multiple comments that this issue is better addressed in the General Code. The Committee also heard concerns from NIST, OWM that the language might limit jurisdictions from considering other factors that might indicate noncompliance with maintenance and adjustment requirements and suggesting that if the proposed language is to be considered further, it should be modified to allow more flexibility. NIST, OWM also questioned whether or not specific guidance for analyzing results should be included in a User Requirement. While many of the factors discussed are appropriate for inspectors to consider in analyzing maintenance of equipment, device owners are required to adjust devices as close to zero as practical. The Committee also heard comments indicating that there may be other factors that affect test results that need to be considered in making an assessment of compliance with G-UR.4.1. The Committee also heard concerns expressed about the need to consider the limits of readability and uncertainty of current test equipment.

Based upon the general lack of support for adding a new requirement to the VTM Code, the Committee decided to withdraw this item from its Agenda.

After hearing an explanation from the submitter and others regarding the difficulties that have been encountered in applying General Code paragraph G-UR.4.1., the Committee believes it might be more appropriate to consider modifications to the General Code to address the concerns and would encourage the submitter and others to consider pursuing this option as an alternative future proposal.

Regional Association Comments:

CWMA supported the item and forwarded it to NCWM, recommending it as a Voting item because it provides specific guidance in the VTM Code and helps support G-UR.4.1.

WWMA did not hear support for the item and the current language in G-UR.4.1. is adequate and provides jurisdictions the ability to make determinations for predominance of error. The WWMA did not forward this item to NCWM.

NEWMA believed this item is covered in the General Code. NEWMA did not forward this item to NCWM.

SWMA heard comments during the Open Hearings in opposition to the item. The SWMA believes this item is sufficiently addressed in the General Code of NIST Handbook 44 and recommended the item be Withdrawn. SWMA did not forward this item to NCWM.

332 LPG AND ANHYDROUS AMMONIA LIQUID-MEASURING DEVICES

332-1 D S.1.4.3. Provisions for Power Loss, S.1.5.1.1. Unit Price, S.1.5.1.2. Product Identity, S.1.6. For Retail Motor Vehicle Fuel Devices Only, S.1.7. For Wholesale Devices Only, UR.2.7. Unit Price and Product Identity, and UR.2..8 Computing Device.

Source:

California Department of Food and Agriculture Division of Measurement Standards (2014)

Purpose:

Add similar Specifications and User Requirements for other retail motor-fuel devices to NIST Handbook 44 Section 3.32. Liquefied Petroleum Gas (LPG) and Anhydrous Liquid-Measuring Devices Code similar to those in Section 3.30 Liquid-Measuring Devices, Section 3.37 Mass flow Meters, and Section 3.39 Hydrogen-Gas Measuring Devices Tentative Code.

Item Under Consideration:

Amend NIST Handbook 44, Liquefied Petroleum Gas and Anhydrous Liquid-Measuring Devices Code as follows:

S.1.4. For Retail Devices Only (No Change)

S.1.4.1. Indication of Delivery (No Change)

S.1.4.2. Return to Zero (No Change)

S.1.4.3. Provisions for Power Loss.

S.1.4.3.1. Transaction Information.

(a) In the event of a power loss, a computing retail liquefied petroleum dispensing device shall display the information needed to complete any transaction in progress at the time of the power loss (such as the quantity and unit price, or sales price) shall be determinable for at least 15 min at the dispenser or at the console if the console is accessible to the customer.

(a) In the event of a power loss, both an electronic digital retail non-computing stationary liquefied petroleum gas dispenser and a vehicle-mounted electronic digital liquefied petroleum gas dispenser shall display the information needed to complete any transaction in progress at the time of the power loss.

S.1.4.3.2. User Information. – The device memory shall retain information on the quantity of fuel dispensed and the sales price totals during power loss.

S.1.5. For Stationary Retail Devices Only.

S.1.5.1. Display of Unit Price and Product Identity. – ~~In a device of the computing type, means shall be provided for displaying on each face of the device the unit price at which the device is set to compute or to deliver as the case may be, and there shall be conspicuously displayed on each side of the device the identity of the product that is being dispensed. If a device is so designed as to dispense more than one grade, brand, blend, or mixture of product, the identity of the grade, brand, blend, or mixture being dispensed shall also be displayed on each face of the device.~~

S.1.5.1.1. Unit Price.

(a) A computing or money-operated device shall be able to display on each face the unit price at which the device is set to compute or to dispense.

(b) Except for dispensers used exclusively for fleet sales, other price contract sales, and truck refueling (e.g., truck stop dispensers used only to refuel trucks), whenever a grade, brand, blend, or mixture is offered for sale from a device at more than one unit price, then all of the unit prices at which that product is offered for sale shall meet the following conditions:

(1) For a system that applies a discount prior to the delivery, all unit prices shall be displayed or shall be capable of being displayed on the dispenser through a deliberate action of the purchaser prior to the delivery of the product. It is not necessary that all of the unit prices for all grades, brands, blends, or mixtures be simultaneously displayed prior to the delivery of the product.

(2) For a system that offers post-delivery discounts on fuel sales, display of pre-delivery unit price information is exempt from (b)(1), provided the system complies with S.1.6.8. Recorded Representations for Transactions Where a Post-Delivery Discount(s) is Provided.

Note: When a product is offered at more than one unit price, display of the unit price information may be through the deliberate action of the purchaser: 1) using controls on the device; 2) through the purchaser's use of personal or vehicle-mounted electronic equipment communicating with the system; or 3) verbal instructions by the customer.

S.1.5.1.2. Product Identity.

(a) A device shall be able to conspicuously display on each side the identity of the product being dispensed.

(b) A device designed to dispense more than one grade, brand, blend, or mixture of product also shall be able to display on each side the identity of the grade, brand, blend, or mixture being dispensed.

S.1.6. ~~For Wholesale Devices Only~~ For Retail Motor Vehicle Fuel Devices Only

S.1.6.1. Zero-Set-Back Interlock, Retail Motor-Fuel Devices. – A device shall be constructed so that:

(a) after a delivery cycle has been completed by moving the starting lever to any position that shuts off the device, an automatic interlock prevents a subsequent delivery until the indicating elements, and recording elements if the device is equipped and activated to record, have been returned to their zero positions;

(b) the discharge nozzle cannot be returned to its designed hanging position (that is, any position where the tip of the nozzle is placed in its designed receptacle and the lock can be inserted)

until the starting lever is in its designed shut-off position and the zero-set-back interlock has been engaged; and

(c) in a system with more than one dispenser supplied by a single pump, an effective automatic control valve in each dispenser prevents product from being delivered until the indicating elements on that dispenser are in a correct zero position.

S.1.6.2. Provisions for Power Loss.

S.1.6.2.1. Transaction Information. – In the event of a power loss, the information needed to complete any transaction in progress at the time of the power loss (such as the quantity and unit price, or sales price) shall be determinable for at least 15 min at the dispenser or at the console if the console is accessible to the customer.

S.1.6.2.2. User Information. – The device memory shall retain information on the quantity of fuel dispensed and the sales price totals during power loss.

S.1.6.3. Display of Unit Price and Product Identity. Except for fleet sales and other price contract sales, a motor vehicle fuel dispenser used to refuel vehicles shall be of the computing type and shall indicate the quantity, the unit price, and the total price of each delivery. The dispenser shall display the volume measured for each transaction.

S.1.6.4. Totalizers for Retail Motor-Fuel Dispensers. – Retail motor-fuel dispensers shall be equipped with a nonresettable totalizer for the quantity delivered through the metering device.

S.1.6.5. Money-Value Divisions. – A computing type shall comply with the requirements of paragraph G-S.5.5. Money-Values, Mathematical Agreement, and the total price computation shall be based on quantities not exceeding 0.05 L for devices indicating in metric units and 0.01 gal intervals for devices indicating in inch-pound units.

S.1.7. For Wholesale Devices Only. (Renumbered - No Change)

UR.2.7. Unit Price and Product Identity.

(a) The following information shall be conspicuously displayed or posted on the face of a retail dispenser used in direct sale:

(1) except for unit prices resulting from any post-delivery discount and dispensers used exclusively for fleet sales, other price contract sales, and truck refueling (e.g., truck stop dispensers used only to refuel trucks), all of the unit prices at which the product is offered for sale; and

(2) in the case of a computing type or money-operated type, the unit price at which the dispenser is set to compute.

Provided that the dispenser complies with S.1.5.1.1. Display of Unit Price, it is not necessary that all the unit prices for all grades, brands, blends, or mixtures be simultaneously displayed or posted.

(b) The following information shall be conspicuously displayed or posted on each side of a retail dispenser used in direct sale:

(1) the identity of the product in descriptive commercial terms; and

(2) the identity of the grade, brand, blend, or mixture that a multi-product dispenser is set to deliver.

UR.2.8 Computing Device. – Any computing device used in an application where a product or grade is offered for sale at one or more unit prices shall be used only for sales for which the device computes and displays the sales price for the selected transaction.

The following exceptions apply:

- (a) Fleet sales and other price contract sales are exempt from this requirement.**
- (b) A truck stop dispenser used exclusively for refueling trucks is exempt from this requirement provided that:**
 - (1) all purchases of fuel are accompanied by a printed receipt of the transaction containing the applicable price per gallon, the total gallons delivered, and the total price of the sale; and**
(Added 1993)
 - (2) unless a dispenser complies with S.1.6.4.1. Display of Unit Price, the price posted on the dispenser and the price at which the dispenser is set to compute shall be the highest price for any transaction which may be conducted.**
(Added 1993)
- (c) A dispenser used in an application where a price per unit discount is offered following the delivery is exempt from this requirement, provided the following conditions are satisfied:**
 - (1) the unit price posted on the dispenser and the unit price at which the dispenser is set to compute shall be the highest unit price for any transaction;**
 - (2) all purchases of fuel are accompanied by a printed receipt recorded by the system for the transaction containing:**
 - a. the product identity by name, symbol, abbreviation, or code number;**
 - b. transaction information as shown on the dispenser at the end of the delivery and prior to any post-delivery discount including the:**
 - 1. total volume of the delivery;**
 - 2. unit price; and**
 - 3. total computed price of the fuel sale prior to post-delivery discounts being applied.**
 - c. an itemization of the post-delivery discounts to the unit price; and**
 - d. the final total price of the fuel sale.**

For systems equipped with the capability to issue an electronic receipt, the customer may be given the option to receive the receipt electronically (e.g., via cell phone, computer, etc.)

Background/Discussion:

NCWM Publication 14, Checklist for Liquefied Natural Gas (LPG) Retail Motor Fuel Devices verifies compliance with specifications, such as: “Power Loss” (which requires a 15 minute power back up) and “Zero-Setback Interlocks.” However, these specifications are not located in Section 3.32. of NIST Handbook 44.

There are LPG devices with NTEP Certificates of Conformance that meet current “power loss” and “zero-setback interlock” requirements. However, there are other LPG retail motor-fuel devices in the field that consist of an

assembly of separable, compatible, and type-certified LPG measuring and indicating elements, key/card lock systems that do not meet the power loss and interlock requirements because those requirements are not within the LPG Code and have not been submitted for type evaluation. This creates unfair competition with holders of type certifications for LPG retail dispensers.

There are newer LPG dispensers coming in to use, where measuring, indicating, and computing elements are assembled in Gilbarco retail motor fuel dispenser housings. These LPG devices serve as both propane bottle fillers and as retail motor fuel devices using separate hoses and nozzles on a dispenser. Many of these dispensers, while they do have a good safety history, are not assembled in compliance with safety standards such as UL 495 or 1238, or NFPA 50, nor are they typically installed in accordance with NFPA 30A or NFPA 70.

Existing retail LPG dispensers can be adapted to fuel LPG-powered motor vehicles by adding a simple adaptor which attaches to the LPG nozzle on the dispensers hose. There are currently five active and two inactive NTEP Certificates of Conformance for LPG retail motor-fuel dispensers listed in the NCWM Database.

NCWM 2014 Interim Meeting: Ms. Juana Williams (NIST, OWM) commented that NIST, OWM believes these changes will better align the LMD and LPG Code with regard to retail dispensing systems. NIST, OWM suggests that the following specific items be considered as the item is further developed:

Nonretroactive Status:

NIST, OWM notes that some of the paragraphs in the original proposal are suggested as nonretroactive requirements. In reviewing these paragraphs, consideration should be given as to the appropriate nonretroactive date to propose, and whether or not the effective dates provided should mirror the effective dates of corresponding paragraphs in the LMD Code.

S.1.4.3. Provisions for Power Loss:

NIST, OWM questions whether or not the provisions for power loss in the proposed paragraph “S.1.4.3.1. Transaction Information” should be restricted to “computing” retail LPG dispensers. This corresponding requirement applies to *all* retail devices in the LMD Code, not just computing-type devices. If a power loss occurs during the use of a digital volume-only retail LPG dispenser, it would seem appropriate to require provisions to ensure that the quantity information can be recalled so that the transaction can be completed. It isn’t clear why there would need to be a distinction between vehicle-mounted and stationary applications.

Additionally, the language proposed in S.1.4.3.1. Transaction Information has some language that doesn’t read correctly. NIST, OWM offers the following alternative:

S.1.4.3. Provisions for Power Loss.

S.1.4.3.1. Transaction Information. – In the event of a power loss, the information needed to complete any transaction in progress at the time of the power loss (such as the quantity and unit price, or sales price) shall be determinable for at least 15 min at the dispenser or at the console if the console is accessible to the customer.

S.1.4.3.2. User Information. – The device memory shall retain information on the quantity of fuel dispensed and the sales price totals during power loss.

S.1.5.1.1. Unit Price: Consideration should be given to whether or not provision needs to be made for “blends” of product for this application. Additionally, the references to paragraph S.1.6.8. refers to an LMD Code paragraph; this reference should be deleted and, perhaps, replaced with a corresponding paragraph of the LPG Code.

Post-Delivery Discounts: For consistency with the LMD Code, the Committee may wish to consider whether provisions for post-delivery discounts should be added to the LPG Code.

S.1.4.1. Indication of Delivery: NIST, OWM suggests that the Committee consider modifying paragraph S.1.4.1. Indication of Delivery as follows so that it mirrors the corresponding paragraph (S.1.6.1. Indication of Delivery) in the LMD Code, both in language and in the requirement for electronic devices to inhibit indications until fueling conditions ensure that the delivery starts on zero.

S.1.4.1. Indication of Delivery. – A retail device shall be constructed to show automatically show on its face the initial zero condition and the ~~amounts~~ quantity delivered up to the nominal capacity of the device. However, the following requirements shall apply:

For electronic devices manufactured prior to January 1, 2006, the first 0.03 L (or 0.009 gal) of a delivery and its associated total sales price need not be indicated.

For electronic devices manufactured on or after January 1, 2006, the measurement, indication of delivered quantity, and the indication of total sales price shall be inhibited until the fueling position reaches conditions necessary to ensure that the delivery starts at zero.

[Nonretroactive as of January 1, 2006]

(Amended 2014)

NIST, OWM suggests the Committee consider what nonretroactive dates, if any, should be associated with this paragraph.

S.1.6.2. Provisions for Power Loss: It would seem that the provisions for power loss are already addressed in the proposed paragraph S.1.4.3. Power Loss. Therefore, NIST, OWM would suggest deleting S.1.6.2. and its subparagraphs S.1.6.2.1. and S.1.6.2.2.

S.1.6.3. Display of Unit Price: This proposed paragraph is logical. However, NIST, OWM questions whether the last sentence regarding volume display is needed given that the “quantity” is already required in the previous sentence.

UR.2.7.(a)(2) Unit Price and Product Identity Wholesale: The word “device” is missing after the word “type.”

UR.2.8. Computing Device: Delete “Added” dates from parts (b)(1) and (b)(2).

This paragraph may also be impacted by action on Items 310-2 and 330-1, which address requirements for recorded representations in the General and LMD Codes. Should the proposal in Item 310-2 to reference the use of electronic receipts be adopted, the corresponding reference in this proposed paragraph (UR.2.8.) should be deleted.

Agreement Between Indications on Auxiliary Elements: Consideration should be given to including a paragraph corresponding to LMD Code paragraph S.1.6.6., which addresses agreement of indications with auxiliary elements such as consoles.

General: As part of this overall proposal, consideration should be given to modifying other sections of the LPG Code to mirror the LMD Code more exactly. This could be done by the Technical Advisor and presented to the submitter as the item is further developed if that would be helpful.

The Committee heard comments from Mr. John Young (Yolo County, California) in support of the proposed changes. The Committee heard comments from NIST, OWM (see above) and Mr. Rich Miller (FMC) regarding the need to more closely examine the power loss requirements, and how the requirements apply to specific categories of LPG metering systems. Mr. Miller noted concern in particular that separate batteries have been required for some vehicle-mounted applications in Europe, and this has proven problematic for companies.

The Committee supports the objective of making changes to align the LPG and the LMD Code with respect to requirements for retail motor-fuel dispensing applications. Based on the comments received, the Committee

believes that additional work is needed before considering the proposal for voting and decided to designate the item as a “Developing” Item to allow the submitter to address the raised points.

2014 Annual Meeting: The Committee heard from Ms. Juana Williams (NIST, OWM) who noted that additional work needs to be done to develop the proposed changes to Section 3.32. NIST, OWM reiterates the comments and suggestions it provided during the 2014 NCWM Interim Meeting and as shown in the report above. Ms. Kristin Macey (California) thanked the Committee and the NCWM for consideration of the item, input received, and noted that California will be tweaking the item and resubmitting it to the regional weights and measures association. Ms. Angela Godwin (Ventura County, California) supported Ms. Macey’s comments and agree that changes are needed to better address LPG motor fuel applications. Mr. Mike Keilty (Endress + Hauser), Chairman of the NTEP Measuring Sector, agreed with the recommendation that the proposal be maintained in a Developing status and indicated that the Measuring Sector will review and provide input on the proposal during its meeting in October 2014.

Regional Association Comments:

CWMA 2013 Interim Meeting: The CWMA believed this item was sufficiently developed and forwarded it to NCWM, recommending that it be a Voting item. At its 2014 Annual Meeting, the CWMA supported continued development of the item.

The WWMA believes the proposal has merit and contains a complete proposal addressing the issues. The WWMA believes more time is needed for input from other stakeholders and regional associations. The WWMA forwarded this item to NCWM and recommended that it be an Informational Item.

SWMA did not receive any comments opposing the item if the section is the same as the LMD Code. The SWMA recommended the item be moved forward to the NCWM as a Voting Item.

NEWMA 2014 Annual Meeting: NEWMA supported continued development of this item.

Additional letters, presentations, and data may have been part of the Committee’s consideration. Please refer to <http://ncwm.net/meetings/annual/publication-16> to review these documents.

332-2 VC S.1.5.3. Recorded Representations, Point-of-Sale Systems

(This item was Adopted.)

Source:

Tennessee Department of Agriculture (2014)

Purpose:

Update the LPG Code in NIST Handbook 44 to include requirements for Retail Dispensers of LPG that are consistent with retail LMD and Mass Flow Meters Code.

Item Under Consideration:

Add the following new paragraph to Section 3.32. LPG and Anhydrous Ammonia Liquid-Measuring Devices Code of NIST Handbook 44 as follows:

S.1.5.3. Recorded Representations, Point-of-Sale Systems. – Except for fleet sales and other price contract sales, a printed receipt providing the following information shall be available through a built-in or separate recording element for all transactions conducted with point-of-sale systems or devices activated by debit cards, credit cards, and/or cash:

(a) the total volume of the delivery;

(b) the unit price;

(c) the total computed price; and**(d) the product identity by name, symbol, abbreviation, or code number.****(Added 2014)****Background/Discussion:**

Alternative Fuels continue to develop market shares. Government programs are sponsoring the installation of alternative fuel dispensing devices in order to assist in developing an infrastructure. It has come to the submitter's attention that the LPG Code has never been updated to be consistent with LMD Code and Mass Flow Meters Code requirements for retail dispensers. We should seek consistency across all device types that are used for the same application; in this case, the application of "retail vehicle fueling." With regard to certain requirements such as displaying information and providing receipts, it shouldn't matter what type of fuel or type of metering technology is used; the basic application is the same.

This proposal is consistent with Mass Flow Meters Code paragraph S.2.7. Recorded Representations, Point-of-Sale Systems, and LMD Code paragraph S.1.6.7. Recorded Representations. There are relatively few LPG dispensers in the U.S. retail market at this time. It is prudent to add this requirement before the market grows and the changes would potentially have a more burdensome impact on existing industry.

NCWM 2014 Interim Meeting: Ms. Juana Williams (NIST, OWM) commented that NIST, OWM believes the proposed change will improve consistency between the LMD Code and the LPG Code. Since the corresponding paragraph in the LMD Code (paragraph S.1.6.7.) is nonretroactive as of January 1, 1986, the Committee may wish to ask for input regarding the retroactive status of the proposed paragraph and even consider whether or not the status of the corresponding LMD Code paragraph might need to be reviewed as a future item.

The Committee heard no objections to the addition of the proposed paragraph or its proposed retroactive status. The Committee believes that the addition of this paragraph will further align the LPG and LMD Codes. Consequently, the Committee recommends this item as a Voting Item.

NCWM 2014 Annual Meeting: The Committee heard comments from Ms. Juana Williams (NIST, OWM) who noted that this item may also be impacted by action on Items 310-2, 330-1, and 330-5B, which address requirements for recorded representations in the General and LMD Codes and recognize the use of electronic receipts. Should the proposal in Item 310-2 be adopted, the Committee may wish to delete the last sentence in this proposal (referencing electronic receipts) prior to presenting the item for a Vote. Based on this suggestion the Committee modified the proposal, eliminating the last sentence so that the proposed paragraph now reads as shown in the "Item Under Consideration."

Regional Association Comments:

SWMA did not hear any comments opposing the item. The Committee supports the proposal as written and agrees with the submitter. SWMA forwarded the item to the NCWM.

336 WATER METERS**336-1 W UR.3. Installation Requirements**

(This item was Withdrawn.)

Source:

Neptune Technology Group Inc. (2013)

Purpose:

Establish installation requirements in the Water Meters Code.

Item Under Consideration:

Add a new paragraph UR.3. as follows:

UR.3. Installation Requirements.

UR.3.1. Manufacturer's Instructions. – A water meter shall be installed in accordance with the manufacturer's instructions. For utility-type water meters, the installation shall be sufficiently secure and rigid to maintain this condition.

Background/Discussion:

There are no installation requirements for utility type meters in the Water Meters Code of NIST Handbook 44. The submitter proposed the following new paragraph be added to Section 3.36.:

UR.3. Installation Requirements.

UR.3.1. Manufacturer's Instructions. – A utility-type water meter shall be installed in accordance with the manufacturer's instructions, and the installation shall be sufficiently secure and rigid to maintain this condition.

2013 NCWM Interim Meeting: The Committee heard comments in support of the proposal from Mr. Noel, who indicated that he also spoke on behalf of Badger, Sensus, Elster-AMCO, and Master Meter and noted that the proposed change would mirror similar paragraphs in other NIST Handbook 44 measuring device codes. Mr. Jim Byers (San Diego County, California) stated that he agreed with the proposed requirement, but notes that the General Code already addresses these requirements. He suggested that, if the language in the General Code is not sufficient, then that language should be reviewed and revised rather than including additional language in the specific code. Ms. Kristin Macy (California) stated that California agrees with Mr. Byers and believes that the language in the General Code is sufficient. Mrs. Juana Williams (NIST, OWM) also acknowledged the similarity with language in other codes.

While the Committee acknowledged comments regarding the redundancy of the proposed paragraph with current General Code requirements, the Committee believes the proposal has merit in helping to ensure proper installation of water meters. The Committee believes the requirement in the first sentence of the proposed paragraph regarding compliance with the manufacturer's instructions should apply to all water meters, not just utility-type meters. Consequently, the Committee modified the language to restrict only the second sentence to utility-type water meters and agreed to propose the modified paragraph (as shown in the "Item Under Consideration" above) for a vote.

One Government representative indicated support; one Government representative indicated a neutral position; and one Government representative indicated opposition for this item on the NCWM Online Position Forum. The opposing comment was accompanied by a statement indicating that paragraph G-UR.2.1. is adequate to address this concern and that paragraph is also more complete and better articulates the requirements.

During its 2013 Annual Meeting Open Hearings, the Committee heard comments in opposition to this item from Mr. Michael Keilty (Endress + Hauser Flowtec AG, USA) and Ms. Macey suggesting that the addition of requirements to address meter installation would be redundant. Mr. Keilty expressed concern that the absence of specific requirements such as these in *all* specific device codes might cause confusion about how or if the General Code paragraph would apply in other cases. Ms. Macey also expressed opposition to distinguishing between non-utility type and utility type water meters. NIST, OWM commented that the proposed language is consistent with that appearing in other device codes in NIST Handbook 44 and intended for the same purpose. The Committee received letters of support from Badger Meter; Elster AMCO Water, LLC; Sensus; Master Meter, Inc.; and Neptune Technology Group. Mr. Dmitri Karimov (Liquid Controls Corporation), speaking on behalf of the companies who were unable to attend this meeting and the Meter Manufacturers Association, also expressed support for this item.

NCWM 2014 Interim Meeting: The Committee heard comments opposing the addition of the proposed paragraph. Comments indicated that the language is redundant with corresponding General Code requirements. Based on these comments, the Committee decided to withdraw the item from its agenda.

Regional Association Comments:

The CWMA believes this item needs no further development and recommended that it be a Voting Item.

The WWMA recognized the redundancy of the proposed language and believes it is sufficiently addressed in G-UR.2.1. The WWMA recommended that this item be Withdrawn.

NEWMA had previously recommended this as a Voting Item. However, based on new information offered by Ms. Macey at the 2013 NCWM Annual Meeting, NEWMA now agreed that the item should be Withdrawn.

SWMA heard comments on behalf of the manufactures in favor of the item. However the SWMA believes the proposed language is already addressed in the General Code. The SWMA recommends this item be Withdrawn.

337 MASS FLOW METERS

S&T Committee Note: Proposals under the Committee's 2014 Interim Agenda Items 337-1 and 337-4 were withdrawn from the agenda in response to comments from the NGSC and the submitter (also a member of the NGSC) who suggested this action because alternative proposals developed by the submitter are intended to replace both items. The alternative proposals (definitions, requirements for quantity indications and markings for the conversion factor to equivalent volume units) and related background information appear under Item 337-2. The Committee also agreed with the NGSC's recommendation to consolidate the proposals under Items 337-2, 337-3, and 337-5 into a single Item 337-2 with Voting status.

337-1 W Appendix D – Definitions: Diesel Liter Equivalent (DLE) and Diesel Gallon Equivalents (DGE); Natural Gas

(This item was Withdrawn.)

Source:

Clean Vehicle Education Foundation (2013)

Purpose:

Enable consumers to make cost and fuel economy comparisons between diesel fuel and natural gas.

Item Under Consideration:

Amend NIST Handbook 44, Appendix D – Definitions as follows:

Diesel Liter Equivalent (DLE). – means 0.756 kg of natural gas.

Diesel Gallon Equivalent (DGE). – means 2.863 kg (6.312 lb) of natural gas.

Background/Discussion:

The gasoline gallon equivalent (GGE) unit was defined by NIST/NCWM in 1994 (See Appendix E) to allow users of natural gas vehicles to readily compare costs and fuel economy of light-duty natural gas vehicles with equivalent gasoline powered vehicles. For the medium and heavy duty natural gas vehicles in widespread use today, there is a need to officially define a unit (already in widespread use) allowing a comparison of cost and fuel economy with diesel powered vehicles. Also natural gas is sold as a vehicle fuel as either Compressed Natural Gas (CNG) or Liquefied Natural Gas (LNG) and each method of sale is measured in mass. Therefore, the generic term natural gas is proposed to be used in NIST Handbooks 44 and 130 without the existing term "compressed." The mathematics justifying the specific quantity (mass) of natural gas in a DLE and DGE is included in Appendix E.

The official definition of a DLE and a DGE will likely provide justification for California, Wisconsin, and any other state to permit retail sales of LNG for heavy-duty vehicles in these convenient units.

NCWM 2013 Interim Meeting: The Committee heard multiple comments in opposition to the proposal. Mr. Keilty opposed the proposal, noting that a truck running on LNG would be dedicated to that type of fuel; thus, there is no need to make comparisons with diesel fuel on an ongoing basis. He stated that he believes natural gas should be sold in units of mass. Ms. Williams reviewed the following points prepared by NIST, OWM and suggested that the Committee consider these points in its deliberations on the proposals for this Item and Item 337-2. A copy of these points was also provided to the S&T Committee and the L&R Committee in writing in advance of the Interim Meeting.

Collaborative Work Effort

Work in joint session with the NCWM L&R Committee on corresponding L&R Agenda Items 232-1 (a proposal to recognize the diesel volume equivalent MOS for vehicle fuel) and 237-1 (a proposal to define the diesel volume equivalent unit in relation to mass), which specify the allowable unit of measurement for advertising and sale of natural gas. This collaboration between Committees will ensure that the proposed volume equivalent unit for a delivery is properly indicated and calculated by a natural gas dispenser.

Facilitate Marketplace-Value Comparisons

A dispenser might serve vehicles that are powered by diesel or gasoline fuel. Therefore, which volume equivalent unit (the DGE or GGE) is appropriate to avoid confusing the consumer? What is the most appropriate means to provide sufficient information to customers attempting to make a comparison of fuel offered by the DGE and GGE, whether at the same station or stations on adjacent street corners? Today's value comparisons are made to petroleum products, but as other alternative fuels proliferate how easy will it be for consumers to make comparisons to other fuels such as electricity or hydrogen?

An alternative that would provide more flexibility for comparison with other fuels and which would potentially create less confusion than permitting multiple different "equivalent" values as "units" of measure is to require the sale of all natural gas in mass units (kg or lb) as suggested by the SWMA. With this approach, customers could still be provided with supplemental information through mechanisms such as pump toppers that provide information about estimated equivalent units of measurement for deliveries indicated in mass as well as information on web sites such as those that already provide information about fuel economy. This approach might also reduce complaints from some suppliers about the accuracy of equivalent values relative to their product.

Another point that has been raised by some in the community and should be considered by the Committee is whether or not "equivalent values" are as necessary as they might have been at one time to encourage consumer acceptance of natural gas as an alternative fuel. For example, the SWMA questioned whether, once a consumer has purchased a vehicle he or she has the need to make ongoing value comparisons or whether this information is more useful prior to purchasing a vehicle. Given the concerns about consumer confusion with a potential proliferation of "equivalent" values at the dispenser, perhaps requiring mass units on the dispenser (with supplemental information about equivalents) is a more appropriate approach.

Compliance of Existing Approved Equipment-Indications

As noted above, NIST, OWM suggests the Committee consider SWMA's recommendation for equipment to indicate in a mass unit of measurement. Currently, there are two LNG dispensers with NCWM NTEP Certificates of Conformance (CC). They are NCWM CC 02-075A2* (Chart Industries) and NCWM CC 04-073A1 (NorthStar, Inc.), which specify these dispensers display in mass. How will the proposal apply to this equipment which may not have the capability to display in units other than mass?

Earlier S&T Committee Positions

Does the S&T Committee plan to revisit its 1999 recommendation where it requested data on LNG be submitted prior to the recognition of this product in a metering application? The Committee might also recall that the S&T Committee took a position in 2008 on a related proposal to recognize the "DGE" recommending that a consensus between stakeholders exist on any single energy value used as a conversion factor. NIST, OWM notes that several CNG suppliers have raised concerns about the use of 5.660 lb of CNG for each GGE commenting that this value is too low for the fuel they are providing to customers. NIST, OWM asks are other factors, which rely on the accurate accounting of vehicle motor fuel sales, aware of and in agreement with the

proposed mass to volume equivalent unit being proposed as a conversion factor value for natural gas (CNG and LNG)?

The data for the heating values cited in Table B.4. “Heat Content for Various Fuels” in the Transportation Energy Data Book Edition 30 (June 2011) was not developed as part of an NCWM study, but represents an account of work by a government sponsored agency to characterize transportation activity and other factors that influence transportation energy use. The book includes a disclaimer which states “in any attempt to compile a comprehensive set of statistics on transportation activity, numerous instances of inadequacies and inaccuracies in the basic data are encountered;” points out that “an appendix is included to document the estimation procedures;” and notes that “neither ORNL nor DOE endorses the validity of these data.”

Ms. Macey opposed the proposal and urged the Committee to stop the proliferation of “equivalent units.” She noted that mass units are perfectly good for routine transactions and echoed comments that comparisons with other fuels are only relevant when making a purchase decision. Ms. Carol Hockert (NIST, OWM) further suggested that during its deliberations, the Committee should consider how the establishment of artificial units would affect metrological traceability. Mr. Dmitri Karimov (Liquid Controls Corporation, LLC), speaking on behalf of MMA, agreed with Ms. Hockert, noting that extensive work is done by companies to establish and maintain metrological traceability and the establishment of what amounts to arbitrary values is counterproductive. Mr. Dan Peterson (Yokogawa Corporation of America) echoed all of the statements made in opposition to the proposal.

Mr. Curtis Williams (CP Williams Energy Consulting) stated that he has had concerns about the use of the GGE and GLE for some years and he is glad that some are questioning the need to reconsider the use of equivalent units. As a participant in the U.S. National Working Group on Hydrogen, he was grateful that the associated code for that alternative fuel established requirements for mass units. He suggested that the Committee also consider examining the potential use of mass units for other fuels and noted that the use of mass units also eliminates questions about temperature compensation.

Ms. Cardin acknowledged the need for the L&R Committee and the S&T Committee to work together on this and related items. She cited two main tasks to be addressed as: 1) What is the right conversion value for the proposed units? and 2) Should units for the sale of natural gas be in “equivalent” units or mass units?

The Committee heard no comments in support of the proposal during its Open Hearings.

During its work sessions at the Interim Meeting, the S&T Committee met with the L&R Committee to discuss this item and related items on the two Committees’ agendas; the corresponding items on the L&R Committee Agenda are Items 232-1 and 237-1. During the joint meeting, the L&R Committee advised the S&T Committee that it had decided to make the related item on their agenda “Informational” to allow additional time for the community to study the issue and hear from other stakeholders in the community. A proposal was made to ask the FALS to deliberate on an appropriate equivalent value for each of the proposed “units.” However, the two Committees recognized that before asking the FALS to expend resources on further definition, the questions and concerns raised in the Open Hearings regarding the appropriateness of recognizing such units should first be addressed. The Committees agreed to recommend to the NCWM Chairman that a small task group be established to further study this issue. The Committees each agreed to develop a list of tasks that they would ask such a task group to take on and to recommend possible members of the group to ensure balanced representation of stakeholders.

After discussion with the L&R Committee, the S&T Committee reviewed and summarized key comments made during the Open Hearings for S&T Committee Agenda Items 337-1 and 337-2:

- Are equivalent units necessary to promote consumer acceptance of this fuel?
- Is there a significant need for continued comparison to other fuels once you have purchased a vehicle? Does this justify the proliferation of “equivalent” values?
- The intent is to add this for medium- and heavy-duty vehicles such as trucks that operate on LNG. Trucks that operate on LNG are generally dedicated fuel vehicles that run only on a single fuel.

- Is the dispenser the appropriate place to make comparisons with other fuels, or is a better place to make those comparisons via mechanisms such as pump toppers, websites, etc.?
- Striking the word “compressed” (in the changes proposed in Item 337-2) expands the proposal to LNG.
- California’s approval of LNG meters indicating in mass units was correct.
- What will the impact be on existing approval of LNG dispensers currently indicating in mass?
- There is much opposition to the proliferation of “equivalent units” for various types of fuels.
- The current recognition of GGE and GLE units has led to complaints about equivalent values from both industry and regulatory officials.
- Mass units should be considered for natural gas and other fuels.
- Will the establishment of equivalent values provide traceability to SI units?
- The community expends significant resources to achieve good meter performance and establishing “fuzzy” equivalent values seems to undermine these efforts.
- The factor for any “equivalent unit” will represent only an “estimate” of an equivalent value.
- There is disagreement amongst the industry regarding the appropriate equivalent value in this proposal. The report containing the data that is referenced as the basis for the proposal includes a disclaimer from Oakridge National Laboratory and the U.S. Department of Energy regarding its validity for other than general use in the transportation industry.
- The S&T Committee only heard comments in opposition to the proposal.
- Harmonization with OIML requirements should be considered in the method of sale and the associated device requirements.

With respect to Items 337-1 and 337-2, the Committee agreed to work collaboratively with the L&R Committee and to develop a small work group to decide: 1) whether or not DLE and DGE should be considered an acceptable method of sale for natural gas; and 2) if so, what should the factor be to determine their equivalents to gasoline. The Committee agreed that the above list of key points and questions heard during its Open Hearings should be considered, along with other Open Hearing comments, by the chairs of both the L&R and S&T Committee in the development of a list of points to be addressed by the Task Group.

On the NCWM Online Position Forum One Government representative indicated support; one Government representative indicated a neutral position; and one Government representative indicated opposition for this item. The neutral position was accompanied by a comment suggesting the establishment of a joint Task Group and encouraging a final recommendation that would clarify whether the proposed units are or are not permitted. The opposing position was accompanied by a comment indicating opposition to artificial units of measure.

Prior to the 2013 Annual Meeting, NCWM Chairman, Mr. Steve Benjamin, appointed the “NCWM Natural Gas Steering Committee,” which will be chaired by Mr. Mahesh Albuquerque (Colorado). The primary charge of the Committee is to educate the membership regarding: the technical issues surrounding this application; the rationale for the proposed changes; the anticipated impact of the proposed changes and issues related to their implementation. The Committee was asked to identify and address questions raised during the 2013 Interim Meeting as well as other venues in an effort to enable NCWM members to make informed decisions about proposals under consideration in this area.

Also prior to the 2013 Annual Meeting, the Committee received a proposal from Mr. Douglas Horne (Clean Vehicle Education Foundation) to modify the “Item Under Consideration.” Mr. Horne proposed separate definitions for CNG and LNG gallon equivalent values. The Committee suggested he work with the Steering Committee to further refine the proposal and suggest changes to the item as appropriate. Mr. Horne’s proposals will be posted on the NCWM website with other documents relative to the committee’s final report. While submitted in an NCWM Form 15 template, Mr. Horne’s proposal is not addressing a new issue, but rather providing comments on a current Item (337-1) on the Committee’s agenda.

During its 2013 Annual Meeting Open Hearings, the Committee heard an update from Steering Committee Chairman, Mr. Albuquerque. He reported that the Steering Committee met for the first time on Sunday, July 14 at the beginning of the Annual Meeting and gathered input from those in the audience. Comments indicated that consumers may find gallon equivalent information to be helpful, but the most equitable method for measuring and selling the product is based on mass measurement.

The S&T Committee heard overwhelming comments opposing the use of gallon equivalents and favoring the use of mass as the method of sale. The Committee also heard multiple comments indicating concern about the establishment of a value that would be an approximation of the actual equivalent for a given transaction. Mr. Horne reported that some states have already or are in the process of enacting defined “gasoline equivalent” values; some adopted earlier versions of the equivalent and some are considering new values as outlined in Mr. Horne’s most recent proposal.

Ms. Macey noted that the NCWM successfully adopted a method of sale for hydrogen fuel based on mass and suggested that the natural gas be held to the same standard. Mr. Keilty commented that sale of natural gas as a vehicle fuel has proliferated globally and those sales are based on mass units.

NIST, OWM acknowledged appreciation of the establishment of the Steering Committee to further study this issue. NIST, OWM encourages the S&T Committee, the Steering Committee, and the weights and measures community to consider the points raised by NIST, OWM during the 2013 Interim Meeting as well as the following in their deliberations of Item 337-1 and Item 337-2:

In addition to discussing the proposals in Items 337-1 and 337-2, NIST, OWM requests that the Task Group specifically discuss and consider whether or not the continued use of the terms “GLE” and “GGE” are appropriate for commercial CNG metering applications. NIST, OWM makes this request based on many of the same points made by NIST, OWM at the 2013 Interim Meeting and also given that:

1. this market is well established and consumer confidence and acceptance of CNG and other alternative fuels is not contingent upon continued comparisons with gasoline;
2. there are other methods for comparing relatively efficiency and costs with gasoline;
3. experience with feedback from the community indicates problems with the application and validity of these units with changing gas supplies;
4. the proposal in Items 337-1 and 337-2 proposes language which would address natural gas as a whole and it is, therefore, appropriate to raise the discussion of whether or not the continued use of non-traceable units is appropriate. Additionally, NIST, OWM suggests that a proposal to eliminate the use of the terms “GLE” and “GGE” in favor of indications in mass units be developed and considered by the NCWM to ensure commercial transactions for natural gas are based on NIST traceable units of measure; and
5. as the number of viable alternative fuel options increase, providing a relatively static comparison with only one alternative fuel will not serve the broad needs of consumers and will make it unlikely that the dispenser is the appropriate location to provide comparison information.

The Committee also heard a comment from Mr. Karimov suggesting that volume units be permitted as a method of sale for LNG.

While many people expressed an understanding of the need for consumers to make comparisons with gasoline, comments indicate that such comparisons would typically be made prior to the purchase of a vehicle and possibly for a short time while becoming accustomed to the vehicle. The Committee heard comments indicating that weights and measures officials would be amenable to permitting the posting or displaying of supplemental information regarding gallon equivalent values.

Additional Contacts: Clean Energy, Seal Beach, California, NGVAmerica, Washington, DC, Clean Vehicle Education Foundation, Acworth, Georgia.

NCWM 2014 Interim Meeting: The NGSC suggested that the Committee withdraw this item. The submitter of this item (who is also a member of the NGSC) submitted an alternative item in 2014 that was intended to replace this item. Consequently, the Committee decided to withdraw this item from its agenda.

Regional Association Comments:

CWMA does not support the item as written and recommends that the status remain as Developing. This is based on the lack of traceability for the conversion units proposed. It is suggested that the conversion units if accepted could be supplemental information. The majority of comments heard were in support of selling this product by a known mass (i.e., pounds or kilograms). In addition there was concern raised regarding the validity of the current CNG conversion units (GLE & GGE).

WWMA heard support from the LNG industry; however, the conversions within their proposals need to be developed. WWMA believes there may be a purpose to the proposal; however, opposition exists between some regulators and stakeholders regarding the use of the volume equivalent unit of measure. WWMA requests the submitter work through the NCWM Natural Gas Steering Committee to refine the proposal. WWMA also has concerns about the source of the conversion factors used in determining the DGE/DLE. The source being the entities sited for establishing the BTU heating value for diesel. The WWMA believes more data is needed to establish densities to LNG. WWMA also believes consideration should be given to neighboring countries' established methods of sale and the units of measure for LNG. WWMA believes this item may be better served as a supplementary advertisement and used for customer information and not for a traceable method of sale. The S&T/L&R Committee's should work together as this item develops. WWMA recommended that the item remain as a Developing Item.

NEWMA recommended that the item remain Informational to give the Steering Committee time to work the items and make suggestions.

SWMA received comments in the Open Hearings indicating that Items 337-2 and 337-3 were proposed to provide clarity. The Committee recommended Items 337-2 and 337-3 replace Item 337-1. The SWMA S&T and L&R Committees met jointly to discuss CNG and LNG items on both agendas. The Committee recommended that this item be withdrawn.

See previous Reports of the National Conference on Weights and Measures for additional history on this item.

- 337-2 V **Appendix D – Definitions: Diesel Liter Equivalent (DLE) and Diesel Gallon Equivalents (DGE) for Compressed Natural Gas and Liquefied Natural Gas; Definition of Gasoline Gallon Equivalent and Gasoline Liter Equivalent for Compressed Natural Gas; S.1.2. Compressed Natural Gas and Liquefied Natural Gas Dispensers; S.1.3.1.1. Compressed Natural Gas Used as an Engine Fuel; S.1.3.1.2. Liquefied Natural Gas Used as an Engine Fuel; S.5.2. Marking of Diesel and Gasoline Volume Equivalent Conversion Factor; Compressed Natural Gas, S.5.3. Marking of Diesel Volume Equivalent Conversion Factor; Liquefied Natural Gas, UR.3.1.1. Marking of Equivalent Conversion Factor for Compressed Natural Gas, UR.3.1.2. Marking of Equivalent Conversion Factor for Liquefied Natural Gas, and UR.3.8. Return of Product to Storage, Retail Compressed Natural Gas and Liquefied Natural Gas**

(This item was returned to Committee for further consideration due to a split vote.)

In June 2014, the S&T Committee modified its online version of this proposal in NCWM Publication 16 in response to a June 10, 2014, request from the NGSC to change the NGSC's March 2014 recommendation for DGE units. Consequently, the S&T Committee agreed that the CNG and LNG conversion factors proposed for use in converting these gases to DGE units should be revised in the Interim Report so that their numerical values are expressed to three decimal places rather than two decimal places.

Source:

Clean Vehicle Education Foundation (2014)

Purpose:

Since natural gas is sold in the retail market place as compressed natural gas (CNG) and liquefied natural gas (LNG) an alternative fuel to gasoline and diesel fuel, the proposed additions and edits to NIST Handbook 44 will provide definitions for volume units of CNG and LNG that are the energy equivalents for diesel liters and gallons so that end users can readily compare cost and fuel economy. At present only equivalents for gasoline are included in NIST Handbooks 44 and 130 for CNG as an engine fuel. The proposal also includes modification to definitions for gasoline volume equivalents to clarify those terms apply to CNG.

Item Under Consideration:

Amend NIST Handbook 44 Appendix D to include new definitions as follows:

diesel gallon equivalent (DGE). – means 6.384 lb of compressed natural gas or 6.059 lb of liquefied natural gas. [3.37]

(Added 20XX)

diesel liter equivalent (DLE). – means 0.765 kg of compressed natural gas or 0.726 kg of liquefied natural gas. [3.37]

(Added 20XX)

Amend NIST Handbook 44, Appendix D definitions as follows:

gasoline gallon equivalent (GGE). – Gasoline gallon equivalent (GGE) means 5.660 lb of **compressed** natural gas.[3.37]

(Added 1994) **(Amended 20XX)**

gasoline liter equivalent (GLE). – Gasoline liter equivalent (GLE) means 0.678 kg of **compressed** natural gas.[3.37]

(Added 1994) **(Amended 20XX)**

Amend NIST Handbook 44, Mass Flow Meters Code paragraphs S.1.2., S.1.3.1.1., and UR.3.8.; delete paragraph S.5.2.; and add new paragraph S.1.3.1.2. as follows:

S.1.2. Compressed Natural Gas and Liquefied Natural Gas Dispensers. – Except for non-retail fleet sales and other price contract sales, a compressed natural gas and liquefied natural gas dispensers used to refuel vehicles shall be of the computing type and shall indicate the quantity, the unit price, and the total price of each delivery. The dispensers shall display the mass measured for each transaction either continuously on an external or internal display accessible during the inspection and test of the dispensers, or display the quantity in mass units by using controls on the device.

(Added 1994) (Amended 20XX)

S.1.3. Units

S.1.3.1.1. Compressed Natural Gas Used as an Engine Fuel. – When compressed natural gas is dispensed as an engine fuel, the delivered quantity shall be measured in mass and indicated in “gasoline liter equivalent (GLE) units,” “gasoline gallon equivalent (GGE) units,” diesel liter equivalent (DLE) units, or diesel gallon equivalent (DGE) units (Also see definitions).

(Added 1994) (Amended 20XX)

S.1.3.1.2. Liquefied Natural Gas Used as an Engine Fuel. – When liquefied natural gas is dispensed as an engine fuel, the delivered quantity shall be measured in mass and indicated in “diesel liter equivalent (DLE) units” or “diesel gallon equivalent (DGE) units” (Also see definitions).

(Added 20XX)

~~S.5.2. Marking of Gasoline Volume Equivalent Conversion Factor. A device dispensing compressed natural gas shall have either the statement “1 Gasoline Liter Equivalent (GLE) is Equal to 0.678 kg of Natural Gas” or “1 Gasoline Gallon Equivalent (GGE) is Equal to 5.660 lb of Natural Gas” permanently and conspicuously marked on the face of the dispenser according to the method of sale used.~~

(~~Added 1994~~)

UR.3.8. Return of Product to Storage, Retail Compressed Natural Gas and Liquefied Natural Gas Dispensers. – Provisions at the site shall be made for returning product to storage or disposing of the product in a safe and timely manner during or following testing operations. Such provisions may include return lines, or cylinders adequate in size and number to permit this procedure.

(Added 1998) (Amended 20XX)

Background/Discussion:

The gasoline gallon equivalent (GGE) unit was defined by NCWM in 1994 to allow users of natural gas vehicles to readily compare costs and fuel economy of light-duty compressed natural gas vehicles with equivalent gasoline powered vehicles. More background on the efforts of NIST/NCWM is available in the Reports of the 78th and 79th NCWM in NIST Special Publication 854 and 870 (see pages 322 and 327, respectively). Natural gas is sold as a vehicle fuel as either compressed natural gas (CNG) or liquefied natural gas (LNG). For medium and heavy duty natural gas vehicles in widespread use today, there is a need to officially define a unit allowing a comparison of cost and fuel economy with diesel powered vehicles. The submitter stated that the official definition of a DLE and a DGE will likely provide justification for California, Wisconsin, and many other states to permit retail sales of CNG for heavy-duty vehicles in these convenient units. The submitter has provided a mathematical justification for the specific quantity (mass) of compressed natural gas in a DLE and DGE which is included in Appendix E.

January 2013 NCWM Interim Meeting

2013 NCWM Interim Meeting: The Committee heard multiple comments in opposition to the proposal. Mr. Michael Keilty (Endress + Hauser Flowtec AG, USA) opposed the proposal, noting that a truck running on LNG would be dedicated to that type of fuel; thus, there is no need to make comparisons with diesel fuel on an ongoing basis. He stated that he believes natural gas should be sold in units of mass.

Ms. Williams (NIST, OWM) reviewed the following points prepared by NIST, OWM and suggested that the

Committee consider these points in its deliberations on the proposals for this item and Item 337-2 (a proposal to recognize a gasoline and diesel volume equivalent unit for CNG, a diesel volume equivalent for LNG engine fuel and for marking the fuel dispenser). A copy of these points was also provided to the S&T Committee and the L&R Committee in writing in advance of the Interim Meeting.

Collaborative Work Effort

Work in joint session with the NCWM L&R Committee on corresponding L&R Agenda Items 232-1 (a proposal to recognize the diesel volume equivalent MOS for vehicle fuel) and 237-1 (a proposal to define the diesel volume equivalent unit in relation to mass) which specify the allowable unit of measurement for advertising and sale of natural gas. This collaboration between committees will ensure that the proposed volume equivalent unit for a delivery is properly indicated and calculated by a natural gas dispenser.

Facilitate Marketplace-Value Comparisons

A dispenser might serve vehicles that are powered by diesel or gasoline fuel. Therefore, which volume equivalent unit (the DGE or GGE) is appropriate to avoid confusing the consumer? What is the most appropriate means to provide sufficient information to customers attempting to make a comparison of fuel offered by the DGE and GGE, whether at the same station or stations on adjacent street corners? Today's value comparisons are made to petroleum products, but as other alternative fuels proliferate how easy will it be for consumers to make comparisons to other fuels such as electricity or hydrogen?

An alternative that would provide more flexibility for comparison with other fuels and which would potentially create less confusion than permitting multiple different "equivalent" values as "units" of measure is to require the sale of all natural gas in mass units (kg or lb) as suggested by the SWMA. With this approach, customers could still be provided with supplemental information through mechanisms such as pump toppers that provide information about estimated equivalent units of measurement for deliveries indicated in mass as well as information on web sites such as those that already provide information about fuel economy. This approach might also reduce complaints from some suppliers about the accuracy of equivalent values relative to their product.

Another point that has been raised by some in the community and should be considered by the Committee is whether or not "equivalent values" are as necessary as they might have been at one time to encourage consumer acceptance of natural gas as an alternative fuel. For example, the SWMA questioned whether, once a consumer has purchased a vehicle he or she has the need to make ongoing value comparisons or whether this information is more useful prior to purchasing a vehicle. Given the concerns about consumer confusion with a potential proliferation of "equivalent" values at the dispenser, perhaps requiring mass units on the dispenser (with supplemental information about equivalents) is a more appropriate approach.

Compliance of Existing Approved Equipment-Indications

As noted above, NIST, OWM suggests the Committee consider SWMA's recommendation for equipment to indicate in a mass unit of measurement. Currently, there are two LNG dispensers with NCWM NTEP Certificates of Conformance (CC). They are NCWM CC 02-075A2* (Chart Industries) and NCWM CC 04-073A1 (NorthStar, Inc.), which specify these dispensers display in mass. How will the proposal apply to this equipment which may not have the capability to display in units other than mass?

Earlier S&T Committee Positions

Does the S&T Committee plan to revisit its 1999 recommendation where it requested data on LNG be submitted prior to the recognition of this product in a metering application? The Committee might also recall that the S&T Committee took a position in 2008 on a related proposal to recognize the "DGE" recommending that a consensus between stakeholders exist on any single energy value used as a conversion factor. NIST, OWM notes that several CNG suppliers have raised concerns about the use of 5.660 lb of CNG for each GGE commenting that this value is too low for the fuel they are providing to customers. NIST, OWM asks are other sectors, which rely on the accurate accounting of vehicle motor fuel sales, aware of and in agreement with the proposed mass to volume equivalent unit being proposed as a conversion factor value for natural gas (CNG and LNG)?

The data for the heating values cited in Table B.4. “Heat Content for Various Fuels” in the Transportation Energy Data Book Edition 30 (June 2011) and used to justify the factors for the conversion of mass to “equivalent volume units” was not developed as part of an NCWM study, but represents an account of work by a government sponsored agency to characterize transportation activity and other factors that influence transportation energy use. The book includes a disclaimer which states “in any attempt to compile a comprehensive set of statistics on transportation activity, numerous instances of inadequacies and inaccuracies in the basic data are encountered;” points out that “an appendix is included to document the estimation procedures;” and notes that “neither ORNL nor DOE endorses the validity of these data.”

Ms. Kristin Macey (California) opposed the proposal and urged the Committee to stop the proliferation of “equivalent units.” She noted that mass units are perfectly good for routine transactions and echoed comments that comparisons with other fuels are only relevant when making a vehicle purchase decision. Ms. Carol Hockert (NIST, OWM) further suggested that, during its deliberations, the Committee should consider how the establishment of artificial units would affect metrological traceability. Mr. Dmitri Karimov (Liquid Controls Corporation, LLC), speaking on behalf of MMA, agreed with Ms. Hockert, noting that extensive work is done by companies to establish and maintain metrological traceability and the establishment of what amounts to arbitrary values is counterproductive. Mr. Dan Peterson (Yokogawa Corporation of America) echoed all of the statements made in opposition to the proposal.

Mr. Curtis Williams (CP Williams Energy Consulting) stated that he has had concerns about the use of the GGE and GLE for some years and he is glad that some are questioning the need to reconsider the use of equivalent units. As a participant in the U.S. National Working Group on Hydrogen, he was grateful that the associated code for that alternative fuel established requirements for mass units. He suggested that the Committee also consider examining the potential use of mass units for other fuels and noted that the use of mass units also eliminates questions about temperature compensation.

Ms. Judy Cardin (Wisconsin) acknowledged the need for the L&R Committee and the S&T Committee to work together on this and related items. She cited two main tasks to be addressed as: What is the right conversion value for the proposed units and should units for the sale of natural gas be in “equivalent” units or mass units?

The Committee heard no comments in support of the proposal during its Open Hearings.

During its work sessions at the Interim Meeting, the S&T Committee met with the L&R Committee to discuss this item and related items on the two Committees’ agendas; the corresponding items on the L&R Committee Agenda are Items 232-1 and 237-1. During the joint meeting, the L&R Committee advised the S&T Committee that it had decided to make the related item on their agenda “Informational” to allow additional time for the community to study the issue and hear from other stakeholders in the community. A proposal was made to ask the FALS to deliberate on an appropriate equivalent value for each of the proposed “units.” However, the two Committees recognized that before asking the FALS to expend resources on further definitions, the questions and concerns raised in the Open Hearings regarding the appropriateness of recognizing such units should first be addressed. The Committees agreed to recommend to the NCWM Chairman that a small task group be established to further study this issue. The Committees each agreed to develop a list of tasks that they would ask such a task group to take on and to recommend possible members of the group to ensure balanced representation of stakeholders.

After discussion with the L&R Committee, the S&T Committee reviewed and summarized key comments made during the Open Hearings for S&T Committee Agenda Items 337-1 and 337-2:

- Are equivalent units necessary to promote consumer acceptance of this fuel?
- Is there a significant need for continued comparison to other fuels once you have purchased a vehicle? Does this justify the proliferation of “equivalent” values?
- The intent is to add this for medium- and heavy-duty vehicles such as trucks that operate on LNG. Trucks that operate on LNG are generally dedicated fuel vehicles that run only on a single fuel.

- Is the dispenser the appropriate place to make comparisons with other fuels, or is a better place to make those comparisons via mechanisms such as pump toppers, websites, etc.?
- Striking the word “compressed” (in the changes proposed in Item 337-2) expands the proposal to LNG.
- California’s approval of LNG meters indicating in mass units was correct.
- What will the impact be on existing approval of LNG dispensers currently indicating in mass?
- There is much opposition to the proliferation of “equivalent units” for various types of fuels.
- The current recognition of GGE and GLE units has led to complaints about equivalent values from both industry and regulatory officials.
- Mass units should be considered for natural gas and other fuels.
- Will the establishment of equivalent values provide traceability to SI units?
- The community expends significant resources to achieve good meter performance and establishing “fuzzy” equivalent values seems to undermine these efforts.
- The factor for any “equivalent unit” will represent only an “estimate” of an equivalent value.
- There is disagreement amongst the industry regarding the appropriate equivalent value in this proposal. The report containing the data that is referenced as the basis for the proposal includes a disclaimer from Oakridge National Laboratory and U.S. Department of Energy regarding its validity for other than general use in the transportation industry.
- The S&T Committee only heard comments in opposition to the proposal.
- Harmonization with OIML requirements should be considered in the method of sale and associated device requirements.

With respect to Items 337-1 and 337-2, the Committee agreed to work collaboratively with the L&R Committee and to develop a small work group to decide: 1) whether or not DLE and DGE should be considered an acceptable method of sale for natural gas; and 2) if so, what should the factor be to determine their equivalents to gasoline. The Committee agreed that the above list of key points and questions heard during its Open Hearings should be considered, along with other Open Hearing comments, by the chairs of both the L&R and S&T Committee in the development of a list of points to be addressed by the Task Group.

On the NCWM Online Position Forum one Government representative indicated support; one Government representative indicated a neutral position; and one Government representative indicated opposition for this item. The neutral position was accompanied by a comment suggesting the establishment of a joint Task Group and encouraging a final recommendation that would clarify whether the proposed units are or are not permitted. The opposing position was accompanied by a comment indicating opposition to artificial units of measure.

Prior to the 2013 Annual Meeting, NCWM Chairman, Steve Benjamin, appointed the “NCWM Natural Gas Steering Committee,” which will be chaired by Mr. Mahesh Albuquerque (Colorado). The primary charge of the Committee is to educate the membership regarding: the technical issues surrounding this application; the rationale for the proposed changes; the anticipated impact of the proposed changes and issues related to their implementation. The Committee was asked to identify and address questions raised during the 2013 Interim Meeting as well as other venues in an effort to enable NCWM members to make informed decisions about proposals under consideration in this area.

Also prior to the 2013 Annual Meeting, the Committee received a proposal from Mr. Douglas Horne (Clean Vehicle Education Foundation) to modify the “Item Under Consideration.” Mr. Horne proposed separate definitions for CNG and LNG gallon equivalent values. The Committee suggested he work with the Steering Committee to further refine the proposal and suggest changes to the item as appropriate. Mr. Horne’s proposals were posted on the NCWM website with other documents relative to the committee’s final report. While submitted in an NCWM Form 15 template, Mr. Horne’s proposal is not addressing a new issue, but rather providing comments on a current item (Item 337-1) on the Committee’s agenda.

July 2013 NCWM Annual Meeting

During its 2013 Annual Meeting Open Hearings, the Committee heard an update from Steering Committee Chairman, Mr. Albuquerque. He reported that the Steering Committee met for the first time on Sunday, July 14 at the beginning of the Annual Meeting and gathered input from in the audience. Comments indicated that consumers may find gallon equivalent information to be helpful, but the most equitable method for measuring and selling the product is based on mass measurement.

2013 NCWM Annual Meeting: The Committee heard comments on Item 337-1 and Item 337-2 jointly. Details of those comments are outlined below.

The S&T Committee heard overwhelming comments opposing the use of gallon equivalents and favoring the use of mass as the method of sale. The Committee also heard multiple comments indicating concern about the establishment of a value that would be an approximation of the actual equivalent for a given transaction. Mr. Horne reported that some states have already or are in the process of enacting defined “gasoline equivalent” values; some adopted earlier versions of the equivalent and some are considering new values as outlined in Mr. Horne’s most recent proposal.

Ms. Macey noted that the NCWM successfully adopted a method of sale for hydrogen fuel based on mass and suggested that the natural gas be held to the same standard. Mr. Keilty commented that sale of natural gas as a vehicle fuel has proliferated globally and those sales are based on mass units.

NIST, OWM acknowledged appreciation of the establishment of the Steering Committee to further study this issue. NIST, OWM encourages the S&T Committee, the Steering Committee, and the weights and measures community to consider the points raised by NIST, OWM during the 2013 Interim Meeting as well as the following in their deliberations of Items 337-1 and Item 337-2:

In addition to discussing the proposals in Items 337-1 and 337-2, NIST, OWM requests that the Steering Committee specifically discuss and consider whether or not the continued use of the terms “GLE” and “GGE” are appropriate for commercial CNG metering applications. NIST, OWM makes this request based on many of the same points made by NIST, OWM at the 2013 Interim Meeting and also given that:

- (1) this market is well established and consumer confidence and acceptance of CNG and other alternative fuels is not contingent upon continued comparisons with gasoline;
- (2) there are other methods for comparing relative efficiency and costs with gasoline;
- (3) experience with feedback from the community indicates problems with the application and validity of these units with changing gas supplies;
- (4) the proposal in Items 337-1 and 337-2 proposes language which would address natural gas as a whole and it is, therefore, appropriate to raise the discussion of whether or not the continued use of non-traceable units is appropriate. Additionally, NIST, OWM suggests that a proposal to eliminate the use of the terms “GLE” and “GGE” in favor of indications in mass units be developed and considered by the NCWM to ensure commercial transactions for natural gas are based on NIST traceable units of

measurement; and

- (5) as the number of viable alternative fuel options increase, providing a relatively static comparison with only one alternative fuel will not serve the broad needs of consumers and will make it unlikely that the dispenser is the appropriate location to provide comparison information.

The Committee also heard a comment from Mr. Karimov (Liquid Controls) suggesting that volume units be permitted as a method of sale for LNG.

While many people expressed an understanding of the need for consumers to make comparisons with gasoline, comments indicate that such comparisons would typically be made prior to the purchase of a vehicle and possibly for a short time while becoming accustomed to the vehicle. The Committee heard comments indicating that weights and measures officials would be amenable to permitting the posting or displaying of supplemental information regarding gallon equivalent values.

January 2014 NCWM Interim Meeting

The Committee met with the L&R Committee to discuss the comments received on Items 337-1 through 337-5 and corresponding items on the L&R Committee's agenda. Although there are three new proposals on the agenda, several appear to require clarification from the submitter on whether they are replacements for several carryover proposals. The two Committees heard an update from Mr. Mahesh Albuquerque (Colorado) speaking as Chairman of the NCWM Natural Gas Steering Committee (NGSC).

Ms. Williams reviewed the following points prepared by NIST, OWM and suggested that the Committees consider these points in their deliberations on the proposals:

- NIST, OWM encourages the:
 - Efforts of the NCWM Natural Gas Steering Committee as it works to provide corresponding proposals to the L&R Committee and S&T Committee.
 - Collaboration with FALS on:
 - Fuel properties data
 - The final vetting of data, formulas, etc. used to arrive at any conversion factors that might be recognized for use in supplemental advertising/sales information
- NIST, OWM notes that some of the current wording in the 2012 and 2013 proposals is somewhat confusing, in part, because several paragraphs include previous conversion factors no longer under consideration.
- The latest proposal encourages a proliferation of equivalent units of measurement, at least six for the CNG and LNG RMFD applications.
- Measurement accuracy and traceability are not achieved through computation of the sale's information in equivalent quantity units since the conversion factor is an estimated value.
- NIST, OWM suggests input from stakeholders such as the CNG and LNG RMFD OEMs and agencies regulating other Sectors (such as the motor fuels taxation departments) in the natural gas infrastructure on the impact of any new proposal.

- NIST, OWM suggests the Committees consider that additional work might be necessary to further modify the code to fully recognize the LNG application. NIST has plans to outline an approach for a similar project.

The S&T Committee and L&R Committee agreed with the suggestions provided by the NGSC for addressing these items. As a result of these discussions, the S&T Committee agreed to the following regarding Items 337-1 through 337-5:

- Withdraw Items 337-1 and 337-4 and consolidate the remaining three items (Items 337-2, 337-3, and 337-5) into a single item.
- Ask that the NGSC rework its proposed changes to NIST Handbook 44 to reflect the comments heard during the Committee's open hearings and in writing.
- Designate the consolidated item as a "Voting" item in anticipation that the NGSC will present a revised version of the proposed changes to NIST Handbook 44 prior to the publication of the Committee's Interim Report.

If the revised version of the code is not presented prior to the publication date or agreement cannot be reached within the NGSC or the S&T Committee on the revised version, the Committee agreed to designate this consolidated item as an "Information" item.

March 2014 Natural Gas Steering Committee Report to the L&R and S&T Committees

The Natural Gas Steering Committee (NGSC) was formed in July 2013 to help understand and educate the NCWM membership regarding the technical issues surrounding the proposed changes to NIST Handbook 44 and NIST Handbook 130 submitted by the Clean Vehicle Education Foundation (CVEF), the anticipated impact of the proposed changes, and issues related to implementation requirements when compressed natural gas (CNG) and liquefied natural gas (LNG) are dispensed and sold as a retail engine fuel in gallon equivalent units.

At the NCWM Interim Meeting in January 2014, Mr. Albuquerque, Chair of the NGSC provided the S&T and L&R Committees with an update from the NGSC, including proposed revisions to the proposals submitted by the CVEF. The NGSC heard comments from the floor related to the proposed revisions and requested additional time to further develop its recommendations. The S&T and L&R Committees agreed to allow the NGSC additional time to meet and develop alternative proposals to those on the S&T and L&R Committees January 2014 agendas, with the expectation that the NGSC recommendations would be ready for inclusion in Publication 16, and moved forward as a Voting item at the July 2014 NCWM Annual Meeting.

Summary of NGSC Meeting Discussions

The NGSC met weekly following the January 2014 Interim Meeting, and focused on modifying the Clean Vehicle Education Foundation (CVEF) 2013 proposals for the recognition of diesel gallon equivalent (DGE) units for CNG/LNG dispenser indications and the method of sale for these two natural gas alternative engine fuels. The NGSC reviewed multiple modifications to those proposals including:

- limiting sales to a single unit of mass measurement enforceable by 2016;
- requiring indications in mass and gasoline and diesel gallon equivalents, while phasing in mass only units;
- require sale by mass as the primary means, but allow for the simultaneous display of volume equivalent units, so long as the purchaser always had access to the mass (traceable) measurement; and
- a proposal from NIST, OWM which would allow the posting of supplemental information to assist consumers in making value comparisons and for use by taxation/other agencies, but requiring the phase in

of indications in mass

The NGSC received:

- input from DOE on the latest edition of the DOE TRANSPORTATION ENERGY DATA BOOK: EDITION 32 July 2013 available on the Oak Ridge National Laboratory website at: <http://cta.ornl.gov/data/index.shtml>;
- updates from CNG (3) and LNG (1) dispenser manufacturers indicating their dispensing systems comply with the requirements in the handbooks, and have the capability to indicate a sale in a single unit of measurement, and any further input on adding displays to the cabinet for additional units would require further cost analysis; while one OEM indicated use of their LNG RMFD in a fleet operation where indications are only in the DGE; and
- feedback from Committee members related to the pros and cons of requiring the indication of sale in mass or gallon equivalent units, including traceability, equipment capabilities, marketplace considerations, and units used by state and federal agencies.

Also noted in the NGSC discussions were:

- how a gallon equivalent unit is derived using energy content, and that the gallon equivalent is defined and measured in terms of mass, not volume;
- for the last 20 years, NIST Handbooks 44 and 130 have required all dispensing equipment to indicate deliveries of natural gas in GGE units to consumers, and in mass units for inspection and testing purposes. CNG RMFD equipment in the most states comply with the requirements in the handbooks;
- international practices for indicating CNG and LNG engine fuel deliveries are predominantly mass; Canada requires LNG indications in the kilogram and the corresponding OIML R 139 “Compressed gaseous fuel measuring systems for vehicles” standard requires indication of the measured gas in mass;
- the variations in engine efficiency relative to a single conversion factor based on an averaged energy content for LNG and the primary focus of the driving public and fleets on mileage rather than petroleum products no longer used to fuel their vehicles;
- the work ahead over the next year by ASTM committees to develop current CNG and LNG fuel quality standards which will need to be referenced in NIST Handbook 130;
- differences in the measurement of the gallon and kilogram – since the gallon is a volume measurement and not an energy measurement, and the NIST Handbook 44 Mass Flow Meters Code includes a requirement for volume-measuring devices with ATC used in natural gas applications to be equipped with an automatic means to make corrections, if the device is affected by changes in the properties of the product; it was also noted that U.S. gasoline and diesel dispensers are not required to have ATC; whereas ATC does occur in sales at the wholesale level;
- how traceability applies to the measurement results at each level of the custody chain (to include the determination of the uncertainty of all calibrations and use of an appropriate unit of measurement); and
- the capabilities of equipment in the marketplace.

A DOE representative supported the use of gallon equivalents, and pointed out that they are used in the DOE Transportation Energy Data Book. The DOE representative also pointed out that other federal agencies including the IRS were requiring use of gallon equivalent units for reporting.

Industry representatives on the NGSC indicated that they are actively campaigning to their state and federal offices, encouraging each government branch to recognize sales of CNG and LNG in gasoline and diesel volume equivalent units. Industry sectors represented on the NGSC indicated that their customers are satisfied with the averaged fuel

energy values that correspond to the conversion factors for CNG and LNG, with only one exception. The exception was a truck stop chain indicating their customers would be amenable to a single conversion factor for both fuels. The CVEF also provided a comparison of GTI's 1992 study results and preliminary data from a 2013 study. The CVEF reported the constituents in natural gas as basically unchanged over 21 years since the NCWM first recognized the GGE. Industry unanimously opposed a recommendation for phasing in mass as the only unit of measurement, noting also that U.S. drivers would be confused by SI units while acknowledging that the United States is in the minority of countries whereby delivery and sales are by equivalent units. At the conclusion of the NGSC deliberations NGV America provided the following statement:

“One of the major advantages of the proposal as currently drafted with inclusion of the DGE and GGE units for natural gas is that this is a proposal that the natural gas industry can support. It further recognizes what is already the preferred practice for how natural gas is measured and dispensed. The latest proposal with DGE and GGE units provides a pathway forward toward a national consensus approach. If the proposal were to instead require use of kilograms or even pounds as the primary method of sale, industry would not support that proposal and likely would strongly oppose it this summer if NCWM were to consider it as a voting issue. Also, if NCWM finalizes on a standard that does not include DGE or GGE, industry is committed to pursuing adoption of an alternative standard on a state by state basis, which could lead to different treatment across the country. Several states have already introduced legislation to recognize the DGE standard (CA, IL, MO, and VA) and I expect more will do so later this year. And you know Colorado and Arkansas already have put in place standards that recognize the DGE units.”

NGSC Recommendations:

After consideration of all of the above, the NGSC recommends alternate proposals to the L&R and S&T Committee Agenda Items which further modify and consolidate the Clean Vehicle Education Foundation 2013 proposals to include:

- (1) requirements for measurement in mass and indication in gallon equivalent units (NIST Handbook 44 paragraphs S.1.3.1.1. and S.1.3.1.2.; and NIST Handbook 130 paragraphs 3.11.2.1. and 3.12.2.1.);
- (2) posting of a label that has both the GGE and DGE or the GLE and DLE for CNG applications (NIST Handbook 44 paragraphs S.5.2., S.5.3., UR.3.1.1., and UR.3.1.2; and NIST Handbook 130 paragraphs 3.11.2.2.2. and 3.12.2.2.2.);
- (3) expression of all equivalent conversion factors expressed in mass units to three significant places beyond the decimal point for consistency (NIST Handbook 44 paragraphs S.5.2., S.5.3., UR.3.1.1., and UR.3.1.2. and Appendix D and NIST Handbook 130 Section 1, paragraphs 3.11.2.2.2. and 3.12.2.2.2.);
- (4) correction of the temperatures in the LNG definition (NIST Handbook 130 Section 1);
- (5) addition of 16 CFR Part 309 for CNG automotive fuel rating (NIST Handbook 130 paragraph 3.11.2.2.5.); and
- (6) reference to NFPA 52 labeling requirements (NIST Handbook 130 paragraph 3.12.2.2.4.)

With regards to NIST Handbook 44 the NGSC recommends withdrawing S&T Agenda Items 337-1 and 337-4 and the consolidation of Agenda Items 337-2, 337-3, and 337-5 into a newly revised single Voting Item designated as Item 337-2. The NGSC also recommends further modifications to corresponding HB 130 proposals to align the definitions of related terms and method of sale with definitions, indicated delivery and dispenser labeling requirements being proposed for NIST Handbook 44.

With regards to NIST Handbook 44, the NGSC also recommends consideration of new a Developing Item addressing proposed changes to paragraph S.3.6. Automatic Density Correction designated as 360-4. This new proposal is consistent with the NGSC decision to encourage further work beyond the current scope of their work on the CVEF's proposals to fully address all LNG applications.

Representatives of the NGSC and the S&T and L&R Committees met in March 2014, all agreed on the course of action outlined above.

Additional Contacts: Clean Energy, Seal Beach, California; NGVAmerica, Washington, DC; Clean Vehicle Education Foundation, Acworth, Georgia. Regional Association Comments: (Fall 2013 Input on the Committee's 2014 Interim Agenda Items 337-1 through 337-5)

There was one neutral position posted on NCWM's 2014 Online Position Forum by NIST, OWM. NIST, OWM offered an alternative proposal as a compromise that would phase in requirements for natural gas vehicle dispensers to measure, indicate, and calculate the total selling price based on mass units (pounds or kilograms), but permit the posting of supplemental information regarding approximate equivalents to other fuels for use by consumers in making value comparisons or by tax agencies. An earlier version was provided to the NCWM Natural Gas Steering Committee. NIST, OWM posted its proposal on the Online Forum so that it could be shared more broadly, and others in the community would have the opportunity to consider alternative solutions and be better able to make informed decisions that meet the needs of the community while preserving the integrity of the measurement process. NIST, OWM provided a copy of the proposal to the S&T Committee and made hard copies available during the open hearings. With this approach, customers could still be provided with supplemental information through mechanisms such as pump toppers and other displays providing information about estimated equivalent units of measurement for deliveries indicated in mass as well as information on web sites such as those that already provide information about fuel economy. This approach might also reduce complaints from some suppliers about the accuracy of equivalent values relative to their product.

2014 NCWM Annual Meeting

NCWM 2014 Annual Meeting: The Committee heard numerous comments in both opposition to and support of the proposal shown in the Item Under Consideration in NCWM Publication 16. These comments are summarized below:

Support:

- Numerous letters of support were received from U.S. Senators and Governors, with wide bipartisan support.
- Allows consumers who may be familiar with volumetric units to make value comparisons.
- Allows for cost comparison between multiple fuel types.
- The proposal is supported by those who build and supply the equipment, vehicle manufacturers, and producers and distributors of natural gas.
- If action isn't taken, the decision will be taken out of the weights and measures jurisdictions' hands at the state and local levels.
- The "GGE" has been in use and accepted for many years.
- If the primary method of sale is mass, it dictates price, sale, and advertising be in mass. Mass units are not consumer friendly. Consumers don't understand price per kilogram or pound for fuel sales.
- Industry stated that equivalent units are what consumers want.
- At least one company reported that all of their business is built around the "DGE," and they would need to retrofit their dispensers if required to measure in mass.

- Natural gas retail dispensers measure in mass, and are inspected and tested using mass units.

Opposition:

- Use of the word approximate.
- This is a marketing rather than technical issue.
- Will there be potential for proliferation of other equivalent units for other alternative fuels?
- There are questions concerning the validity of the conversion values, and whether adequate research has been done to develop the values.
- Including more than one equivalent value could lead to consumer confusion.
- The proposal is not aligned with how natural gas is being sold in the rest of the world.
- A jurisdiction stated that consumers hadn't been asked how they want natural gas sold.
- Is there a need for ongoing value comparisons if a vehicle is dedicated to run on natural gas fuel?
- Measurement science needs to be based on traceable standards. Equivalent units are not traceable.
- Consumers may need to make comparisons with multiple different fuel types such as diesel, biodiesel, gasoline, fuel ethanol, electric, hydrogen, LNG, and others. What is the most appropriate means to provide sufficient information to customers attempting to make value comparisons?
- Equivalent units would be better provided as supplemental information rather than the basis for commercial transactions.

Other technical points that were raised include the following:

- NTEP certificates have already been issued for five LNG dispensers that measure and indicate in mass units only. How will the proposed changes affect this equipment?

The Committee received an alternative proposal from NIST, OWM that would require dispensers to measure, indicate, and calculate the total selling price based on mass units (pounds or kilograms), but permit the posting of supplemental information regarding approximate equivalents to other fuels for use by consumers when making value comparisons or for use by tax agencies. Based upon multiple requests from the regional weights and measures association meetings during the 2014 NCWM Annual Meeting and the Committee's open hearings, the Committee agreed to include this proposal in its Final Report. These proposed changes to Section 3.37. Mass Flow Meters Code are shown in the following table.

Summary of Alternative Proposal from NIST:

This alternative proposal was offered as a compromise that would phase in requirements for natural gas vehicle dispensers to measure, indicate, and calculate the total selling price based on mass units (pounds or kilograms), but permit the posting of supplemental information regarding approximate equivalents to other fuels for use by consumers in making value comparisons or by tax agencies while preserving the integrity of the measurement process. With this approach, customers could still be provided with supplemental information through mechanisms such as pump toppers or other displays that provide information about estimated equivalent units of measurement for deliveries indicated in mass as well as information on web sites such as those that already provide information about fuel economy. This approach might also reduce complaints from some suppliers about the accuracy of

equivalent values relative to their product.

S.1. Indicating and Recording Elements.

...

S.1.2. ~~Compressed~~ Natural Gas Dispensers. – Except for fleet sales and other price contract sales, a ~~compressed~~ natural gas dispenser used to refuel vehicles shall be of the computing type and shall indicate the quantity, the unit price, and the total price of each delivery. ~~The dispenser shall display the mass measured for each transaction either continuously on an external or internal display accessible during the inspection and test of the dispenser, or display the quantity in mass units by using controls on the device.~~

(Added 1994) (Amended 20XX)

S.1.3. Units.

S.1.3.1. Units of Measurement. – Deliveries shall be indicated and recorded in grams, kilograms, metric tons, pounds, tons, and/or liters, gallons, quarts, pints and decimal subdivisions thereof. The indication of a delivery shall be on the basis of apparent mass versus a density of 8.0 g/cm³. The volume indication shall be based on the mass measurement and an automatic means to determine and correct for changes in product density.

(Amended 1993 and 1997)

S.1.3.1.1. ~~Compressed~~ Natural Gas Used as an Engine Fuel. – When ~~compressed~~ natural gas is dispensed as an engine fuel, the delivered quantity shall be indicated as follows:

- (a) Effective and Nonretroactive as of January 1, 2016, the delivered quantity shall be indicated in mass units in terms of kilograms or pounds and decimal subdivisions thereof.

This paragraph will become retroactive on January 1, 2017.

(Added 20XX)

- (b) For dispensers manufactured prior to January 1, 2016, the dispenser shall display the mass measured for each transaction, either continuously on an external or internal display accessible during the inspection and test of the dispenser, or display the quantity in mass units by using controls on the device. The delivered quantity shall be indicated in mass or in “gasoline liter equivalent (GLE) units” or “gasoline gallon equivalent (GGE) units.” (Also see definitions.)

(Added 1994) (Amended 20XX)

Paragraph S.1.3.1.1.(b) will be removed in the 2017 edition of NIST Handbook 44 when paragraph S.1.3.1.1.(a) becomes retroactive.

S.1.3.1.2. Natural Gas Used as an Engine Fuel, Supplemental Information. – Dispensers of natural gas dispensed as an engine fuel may include supplemental information to assist consumers in making value comparisons with gasoline and diesel fuel and for use by taxation departments and other agencies that may need an approximation thereof. Supplemental information shall not appear adjacent or in close proximity to the primary display and shall be positioned far enough from that display so as to ensure that the quantity, unit price, and total price for the transaction are clear and easily understood.

Supplemental units shall be clearly designated with the phrase “The following information is provided for comparison with other vehicle fuels and is not to be used as a basis for

commercial transactions.”

Supplemental units shall be displayed using one or more of the following statements.

For compressed natural gas:

1 kg of Compressed Natural Gas is Equal to 1.4749 Gasoline Liter Equivalent (GLE)

1 kg of Compressed Natural Gas is Equal to 0.3896 Gasoline Gallon Equivalent (GGE)

1 kg of Compressed Natural Gas is Equal to 1.3072 Diesel Liter Equivalent (DLE)

1 kg of Compressed Natural Gas is Equal to 0.3455 Diesel Gallon Equivalent (DGE)

1 lb of Compressed Natural Gas is Equal to 0.669 Gasoline Liter Equivalent (GLE)

1 lb of Compressed Natural Gas is Equal to 0.177 Gasoline Gallon Equivalent (GGE)

1 lb of Compressed Natural Gas is Equal to 0.593 Diesel Liter Equivalent (DLE)

1 lb of Compressed Natural Gas is Equal to 0.157 Diesel Gallon Equivalent (DGE)

For liquefied natural gas:

1 kg of Liquefied Natural Gas is Equal to 1.3768 Diesel Liter Equivalent (DLE)

1 kg of Liquefied Natural Gas is Equal to 0.3638 Diesel Gallon Equivalent (DGE)

1 lb of Liquefied Natural Gas is Equal to 0.625 Diesel Liter Equivalent (DLE)

1 lb of Liquefied Natural Gas is Equal to 0.165 Diesel Gallon Equivalent (DGE)

...

S.1.3.3. Maximum Value of Quantity-Value Divisions.

- (a) The maximum value of the quantity-value division for liquids shall not be greater than 0.2 % of the minimum measured quantity.
- (b) Effective and nonretroactive as of January 1, 2016, the maximum value of the mass division for dispensers of natural gas used to refuel vehicles shall not exceed 0.001 kg or 0.001 lb.

Note: Paragraph S.1.3.3.(b) will become retroactive effective January 1, 2017.

- (c) For dispensers of ~~compressed~~ natural gas used to refuel vehicles **and manufactured prior to January 1, 2016**, the value of the division for the gasoline liter equivalent shall not exceed 0.01 GLE; the division for gasoline gallon equivalent (GGE) shall not exceed 0.001 GGE. The maximum value of the mass division shall not exceed 0.001 kg or 0.001 lb.

Note: Paragraph S.1.3.3.(c) will be removed in the 2017 edition of NIST Handbook 44 when Paragraph S.1.3.3.(b) becomes retroactive.

(Amended 1994 ~~and 20XX~~)

S.5. Markings.

...

S.5.2. Marking of Gasoline Volume Equivalent Conversion Factor. – ~~A device~~ **Dispensers manufactured prior to January 1, 2016,** dispensing compressed natural gas shall have either the statement “1 Gasoline Liter Equivalent (GLE) is Equal to 0.678 kg of Natural Gas” or “1 Gasoline Gallon Equivalent (GGE) is Equal to 5.660 lb of Natural Gas” permanently and conspicuously marked on the face of the dispenser according to the method of sale used.

As of January 1, 2017, devices must indicate as specified in S.1.3.1.1.(a) and any information providing equivalent units may only be included as supplemental information as specified in S.1.3.1.2.

Paragraph S.5.2. will be removed from the 2017 edition of NIST Handbook 44 when paragraph S.1.3.1.1.(a) becomes retroactive.

(Added 1994) (~~Amended~~ **20XX**)

UR.3. Use of Device.

...

UR.3.8. Return of Product to Storage, Retail Compressed Natural Gas and Liquefied Natural Gas Dispensers. – Provisions at the site shall be made for returning product to storage or disposing of the product in a safe and timely manner during or following testing operations. Such provisions may include return lines, or cylinders adequate in size and number to permit this procedure.

(Added 1998) (~~Amended~~ **20XX**)

Because many of these issues are dependent upon defining the proper method of sale, the Committee met jointly with the L&R Committee to discuss the comments received on the S&T and L&R proposals on the issues relating to natural gas.

The S&T Committee identified the method of sale by mass versus equivalent volumetric units as the most significant concern based on comments heard on this proposal. In addition to support for this proposal, there were also concerns regarding the use of the word “approximately” for labeling purposes; “multiple equivalent units” labeled on the same dispenser; “tax issues;” and other less commonly expressed issues. It was decided to eliminate the labeling altogether and not delay the effective date, thereby, addressing all three concerns. Consequently, based upon the comments received and its deliberations, the Committee agreed to modify the Item Under Consideration shown in NCWM Publication 16 as follows:

- Delete existing paragraph S.5.2. Marking of Equivalent Conversion Factor for Compressed Natural Gas in Section 3.37. Mass Flow Meters Code.
- Delete paragraph S.5.2., including the following proposed changes from the Item Under Consideration shown in Publication 16:

S.5.2. Marking of Equivalent Conversion Factor for Compressed Natural Gas. – A device dispensing compressed natural gas shall have either the statements “1 Gasoline Liter Equivalent (GLE) is **Approximately** Equal to 0.678 kg of **Compressed** Natural Gas” and “1 Diesel Liter Equivalent (DLE) is **Approximately** Equal to 0.765 kg of **Compressed** Natural Gas” or the statements “1 Gasoline Gallon Equivalent (GGE) is **Approximately** Equal to 5.660 lb of **Compressed** Natural Gas” and “1 Diesel Gallon Equivalent (DGE) is **Approximately** Equal to 6.384 lb of **Compressed** Natural Gas” permanently and conspicuously marked on the face of the dispenser according to the method of sale used.

(Added 1994) (Amended 20XX)

- Delete the following new paragraphs from the Item Under Consideration shown in Publication 16:

S.5.3. Marking of Diesel Volume Equivalent Conversion Factor for Liquefied Natural Gas. – A device dispensing liquefied natural gas shall have either the statement "1 Diesel Liter Equivalent (DLE) is Approximately Equal to 0.726 kg of Liquefied Natural Gas" or "1 Diesel Gallon Equivalent (DGE) is Approximately Equal to 6.059 lb of Liquefied Natural Gas" permanently and conspicuously marked on the face of the dispenser according to the method of sale used.

(Added 20XX)

UR.3.1.1. Marking of Equivalent Conversion Factor for Compressed Natural Gas. – A device dispensing compressed natural gas shall have either the statements "1 Gasoline Liter Equivalent (GLE) is Approximately Equal to 0.678 kg of Compressed Natural Gas" and "1 Diesel Liter Equivalent (DLE) is Approximately Equal to 0.765 kg of Compressed Natural Gas" or the statements "1 Gasoline Gallon Equivalent (GGE) is Approximately Equal to 5.660 lb of Compressed Natural Gas" and "1 Diesel Gallon Equivalent (DGE) is Approximately Equal to 6.384 lb of Compressed Natural Gas" permanently and conspicuously marked on the face of the dispenser according to the method of sale used.

(Added 20XX)

UR.3.1.2. Marking of Equivalent Conversion Factor for Liquefied Natural Gas. - A device dispensing liquefied natural gas shall have either the statement "1 Diesel Liter Equivalent (DLE) is Approximately Equal to 0.726 kg of Liquefied Natural Gas" or "1 Diesel Gallon Equivalent (DGE) is Approximately Equal to 6.059 lb of Liquefied Natural Gas" permanently and conspicuously marked on the face of the dispenser according to the method of sale used.

(Added 20XX)

The Item Under Consideration *above* reflects these modifications.

Regional Association Comments:

General Comments following the 2014 NCWM Interim Meeting:

At its 2014 Annual Meeting, the CWMA recommended that the status of this item be changed from Voting to Informational based on discussion heard during the joint meeting of the L&R and S&T Committees. At that joint meeting, the two Committees concurred the items have merit, but questions and concerns over accuracy of this final proposal still remain. Both Committees agreed to move the item forward as an Information item. During the L&R Committee's work session, discussion took place regarding the inconsistency in language in the method of sale in L&R Item 232-3, Section 2.27.2. compared to the method of sale with L&R Item 237-2, Section 3.11.2.1. Additionally, the Committee discussed including the same number of significant digits in the conversions specified in the DGE and DLE equivalent values. The Chairman of the CWMA L&R Committee communicated these two concerns to the Chairman of the NCWM Natural Gas Steering Committee.

NEWMA 2014 Annual Meeting: NEWMA recommended the status of this item be changed from Voting to Informational after the item failed to receive a motion to move it forward as a Voting item on the National S&T agenda. The Informational status was assigned to address the continued debate on marketing, tax issues, conversion values, testing, and method of sale requirements.

Amend NIST Handbook 44, Appendix D – New Definitions for Diesel Volume Equivalents for Natural Gas (this approach established a single factor for both CNG and LNG)[submitted 2013, formerly Item 337-1]

CWMA 2013 Interim Meeting: The CWMA did not support the item as written and recommended that the status remains as Developing. This was based on the lack of traceability for the conversion units proposed. The CWMA suggested that the conversion units if accepted could be supplemental information. The majority of comments heard were in support of selling this product by a known mass (i.e., pounds or kilograms). In addition there was concern raised regarding the validity of the current CNG conversion units (GLE and GGE).

WWMA fall 2013 meeting: The WWMA heard support from the LNG industry however the conversions within their proposals need to be developed. WWMA believes there may be a purpose to the proposal; however opposition exists between some regulators and stakeholders regarding the use of the volume equivalent unit of measure. WWMA requests the submitter work through the NCWM Natural Gas Steering Committee to refine the proposal. WWMA also has concerns about the source of the conversion factors used in determining the DGE/DLE. The source being the entities sited for establishing the BTU heating value for diesel. The WWMA believes more data is needed to establish densities for LNG. WWMA also believes consideration should be given to neighboring countries' established methods of sale and the units of measure for LNG. WWMA believes this item may be better served as a supplementary advertisement and used for customer information and not for a traceable method of sale. The S&T/L&R Committee's should work together as this item develops. WWMA recommended that the item remain as a Developing item.

NEWMA 2013 Interim Meeting: NEWMA recommended the item remain Informational to give the Steering Committee time to work the items and make suggestions.

SWMA received comments in the Open Hearings indicating that Items 337-2 and 337-3 were proposed to provide clarity. The Committee recommended Items 337-2 and 337-3 replace Item 337-1. The SWMA S&T and L&R Committees met jointly to discuss CNG and LNG items on both agendas. The Committee recommended that this item be Withdrawn.

Amend NIST Handbook 44, Appendix D – New Definitions for Diesel Volume Equivalents for Compressed Natural Gas [formerly Item 337-2]

CWMA did not forward this item to NCWM, stating it is a duplicate to correct the conversion factor.

WWMA did not forward this item to NCWM and recommends that the submitter incorporate the pertinent information into Item 337-1.

NEWMA forwarded the item to NCWM and recommended the item be designated as Informational to give the Steering Committee time to work the items and make suggestions.

SWMA received comments in the Open Hearing indicating that Items 337-2 and 337-3 were proposed to provide clarity. The Committee recommends Items 337-2 and 337-3 replace Item 337-1. The SWMA S&T and L&R Committees met jointly to discuss CNG and LNG items on both agendas. SWMA forwarded this item to NCWM recommending it as a Developing item.

Amend NIST Handbook 44, Appendix D – New Definitions for Diesel Volume Equivalents for Liquefied Natural Gas [submitted 2014, formerly Item 337-3]

CWMA did not support the item as written and recommends that the status remain as Developing. This is based on the lack of traceability for the conversion units proposed. It is suggested that the conversion units if accepted could be supplemental information. The majority of comments heard were in support of selling this product by a known mass (i.e., pounds or kilograms). In addition there was concern raised regarding the validity of the current CNG conversion units (GLE and GGE).

WWMA did not forward this item to NCWM and recommends that the submitter incorporate the pertinent information into Item 337-1.

NEWMA forwarded the item to NCWM and recommended the item be designated as Informational to give the Steering Committee time to work the items and make suggestions.

SWMA received comments in the Open Hearing indicating that Items 337-2 and 337-3 were proposed to provide clarity. The Committee recommends Items 337-2 and 337-3 replace Item 337-1. The SWMA S&T and L&R Committees met jointly to discuss CNG and LNG items on both agendas. SWMA forwarded this item to NCWM recommending it as a Developing item.

Amend paragraphs S.1.2., S.1.3.1.1., and S.5.2. [submitted 2013, formerly Item 337-4]

CWMA did not support the item as written and recommends that the status remain as Developing. This is based on the lack of traceability for the conversion units proposed. It is suggested that the conversion units, if accepted, could be supplemental information. The majority of comments heard were in support of selling this product by a known mass, (i.e., pounds or kilograms). In addition there was concern raised regarding the validity of the current CNG conversion units (GLE and GGE).

The WWMA heard no support on this item and recommended that it be Withdrawn. The intent of the proposal is to make cost comparisons between diesel fuel and natural gas. The WWMA believes this proposal doesn't meet the historic definition of "Cost Comparison" and shouldn't be a specification item in NIST Handbook 44. The WWMA believes Natural Gas should be sold in traceable units and not artificial equivalent units. The NCWM Natural Gas Steering Committee should take into consideration global method of sale and advertising of LNG/CNG. The WWMA believes the urgency of this issue demands quick action by the NCWM because these devices are growing quickly in the market place.

NEWMA forwarded the item to NCWM and recommended the item be designated as Informational to give the Steering Committee time to work the items and make suggestions.

SWMA heard comments in open hearing indicating that Item 337-5 was proposed to further clarify Item 337-4. The Committee agreed with comments heard that Item 337-4 continue to be a Developing item. Based on the comments received the Committee believed this item may be more appropriate as a user requirement and should be kept as developmental status with review by Steering Committee. The Committee believed that the identity should be indicated in a single unit. The SWMA, the S&T and L&R Committees met jointly to discuss CNG and LNG items on both agendas.

Amend paragraphs S.1.2., S.1.3.1.1., and S.5.2., and add new paragraphs S.1.3.1.2., and S.5.3. [submitted 2014, formerly 337-5]

CWMA did not support the item as written and recommends that the status remain as Developing. This is based on the lack of traceability for the conversion units proposed. It is suggested that the conversion units if accepted could be supplemental information. The majority of comments heard were in support of selling this product by a known mass (i.e., pounds or kilograms). In addition there was concern raised regarding the validity of the current CNG conversion units (GLE and GGE).

The WWMA heard no support on this item and recommended that it be Withdrawn. The intent of the proposal is to make cost comparisons between diesel fuel and natural gas. The WWMA believes this proposal doesn't meet the historic definition of "Cost Comparison" and shouldn't be a specification item in NIST Handbook 44. The WWMA believes natural gas should be sold in traceable units and not artificial equivalent units. The NCWM Natural Gas Steering Committee should take into consideration global method of sale and advertising of LNG/CNG. The WWMA believes the urgency of this issue demands quick action by the NCWM because these devices are growing quickly in the market place.

NEWMA forwarded the item to NCWM and recommended the item be designated as Informational to give the Steering Committee time to work the items and make suggestions.

SWMA heard comments in the open hearing indicating that Item 337-5 was proposed to further clarify Item 337-4. The Committee agreed with comments heard that Item 337-4 continue to be a developing item. Based on the comments received the Committee believed this item may be more appropriate as a user requirement and should be kept as Developmental status with review by the Steering Committee. The Committee believed that the identity should be indicated in a single unit. The SWMA, S&T Committee, and L&R Committee met jointly to discuss CNG and LNG items on both agendas

With respect to the Item Under Consideration, the Committee received additional letters of support from:

- ANGI Energy Systems;
- California Natural Gas Vehicle Coalition;
- Maine Clean Communities = MC²;
- Sacramento Clean Cities Coalition,; and
- Questar Gas Company.

337-3 Appendix D – Definitions: Diesel Liter Equivalent (DLE) and Diesel Gallon Equivalents (DGE) for Liquefied Natural Gas

The Committee considered the following proposal to establish definitions in Appendix D for “Diesel Liter Equivalent (DLE)” and “Diesel Gallon Equivalent (DGE).” This item (along with accompanying recommendations and background information) was consolidated with Item 337-2 as a result of action by the Committee at the 2014 NCWM Interim Meeting. See Item 337-2 for additional details.

As a result of the June 12, 2014, discussions of the S&T Committee, in conjunction with NGSC recommendations, it became necessary to further clarify the status of Agenda Items 337-3 and 337-5. In March 2014, the Committee agreed with the NGSC’s recommendation for modifications of the proposed NIST Handbook 44 requirements in these agenda items and their consolidation into a single voting item under Agenda Item 337-2. Consequently, the “V” (Voting) designation was removed from Agenda Items 337-3 and 337-5.

Source:

Clean Vehicle Education Foundation (2014)

Purpose:

Since liquefied natural gas (LNG) is sold in the retail market place as an alternative fuel to diesel fuel, the proposed additions and edits to NIST Handbook 44 will provide definitions for liquefied natural gas (LNG) equivalents for diesel liters and gallons so that end users can radially compare cost and fuel economy. At present no LNG equivalents for diesel are included in the handbooks.

Item under Consideration:

Amend NIST Handbook 44, Appendix D as follows:

Diesel Liter Equivalent (DLE). – Means 0.7263 kg of liquefied natural gas.

Diesel Gallon Equivalent (DGE). – Means 2.749 kg (6.06 lb) of liquefied natural gas.

337-4 W S.1.2. Compressed Natural Gas Dispensers, S.1.3.1.1. Compressed Natural Gas Used as an Engine Fuel, S.5.2. Marking of Gasoline Volume Equivalent Conversion Factor; Natural Gas

(This item was Withdrawn.)

Source:

Clean Vehicle Education Foundation (2013)

Purpose:

Enable consumers to make cost and fuel economy comparisons between diesel fuel and natural gas.

Item Under Consideration:

Amend paragraphs S.1.2., S.1.3.1.1., and S.5.2. as follows:

S.1.2. ~~Compressed~~–Natural Gas Dispensers. – Except for fleet sales and other price contract sales, a ~~compressed~~ natural gas dispenser used to refuel vehicles shall be of the computing type and shall indicate the quantity, the unit price, and the total price of each delivery. The dispenser shall display the mass measured for each transaction either continuously on an external or internal display accessible during the inspection and test of the dispenser, or display the quantity in mass units by using controls on the device.

(Added 1994) (Amended 20XX)

S.1.3.1.1. ~~Compressed~~–Natural Gas Used as an Engine Fuel. – When ~~compressed~~–natural gas is dispensed as an engine fuel, the delivered quantity shall be indicated in: ~~“gasoline liter equivalent (GLE) units” or “gasoline gallon equivalent (GGE) units” (see definitions).~~

(a) “gasoline liter equivalent (GLE) units” or gasoline gallon equivalent (GGE) units”,

(b) “diesel liter equivalent (DLE) units” or “diesel gallon equivalent (DGE) units” (see definitions).

(Added 1994) (Amended 20XX)

S.5.2. Marking of Diesel and Gasoline Volume Equivalent Conversion Factor. – A device dispensing ~~compressed~~–natural gas shall have: ~~either the statement “1 Gasoline Liter Equivalent (GLE) is Equal to 0.678 kg of Natural Gas” or “1 Gasoline Gallon Equivalent (GGE) is Equal to 5.660 lb of Natural Gas” permanently and conspicuously marked on the face of the dispenser according to the method of sale used.~~

(a) either the statement “1 Gasoline Liter Equivalent (GLE) is Equal to 0.678 kg of Natural Gas” or “1 Gasoline Gallon Equivalent (GGE) is Equal to 5.660 lb of Natural Gas”,

(b) either the statement “1 Diesel Liter Equivalent (DLE) is Equal to 0.756 kg of Natural Gas” or “1 Diesel Gallon Equivalent (DGE) is Equal to 6.312 lb of Natural Gas” permanently and conspicuously marked on the face of the dispenser according to the method of sale used.

(Added 1994) (Amended 20XX)

Background/Discussion:

The gasoline gallon equivalent (GGE) unit was defined by NIST/NCWM in 1994 (see Appendix E) to allow users of natural gas vehicles to readily compare costs and fuel economy of light-duty natural gas vehicles with equivalent gasoline powered vehicles. For the medium and heavy duty natural gas vehicles in widespread use today, there is a need to officially define a unit (already in widespread use) allowing a comparison of cost and fuel economy with diesel powered vehicles. Also natural gas is sold as a vehicle fuel as either Compressed Natural Gas (CNG) or Liquefied Natural Gas (LNG) and each method of sale in measure in mass. Therefore, the generic term “natural gas” is proposed to be used in NIST Handbooks 44 and 130 with out the existing term “compressed.” The mathematics justifying the specific quantity (mass) of natural gas in a DLE and DGE is included in Appendix E.

The official definition of a DLE and a DGE will likely provide justification for California, Wisconsin, and any other state to permit retail sales of LNG for heavy-duty vehicles in these convenient units.

NCWM 2013 Interim Meeting: The Committee heard comments from Mr. Keilty who expressed concern about the adoption of the proposed equivalent value as a unit of measure. He noted that the intent of this item is not to allow the user to toggle between mass units and equivalent units at the push of a button. He also noted that if the units are set as “DLE” or “DGE,” the customer cannot also view units in “GLE” or “GGE.” Mr. Dmitri Karimov (Liquid Controls Corporation, LLC), indicated opposition to the proposal to strike the work “compressed.” Ms. Williams referenced NIST, OWM’s comments made in association with Agenda Item 337-1 and suggested that the Committee consider those same comments in their deliberations of this item.

The Committee heard no comments in support of the proposal during its Open Hearings. See Item 337-1 for details regarding the S&T Committee's collaborations with the NCWM L&R Committee on Items 337-1 and 337-2 on the S&T Committee's agenda and Items 232-1 and 237-1 on the L&R Committee's agenda.

On the NCWM Online Position Forum, two Government representatives indicated a neutral position and one Government representative indicated opposition for this item. The neutral position was accompanied by a comment suggesting the establishment of a Joint Task Group and encouraging a final recommendation that would clarify whether the proposed units are or are not permitted. The opposing position was accompanied by a comment indicating opposition to artificial units of measure and noting that establishment of DGE and DLE values perpetuate the use of artificial units.

NCWM 2013 Annual Meeting: The Committee heard comments on Items 337-1 and 337-2 jointly. Details of comments are included in Item 337-1.

Additional Contacts: Clean Energy, Seal Beach, California; NGVAmerica, Washington, D.C.; and Clean Vehicle Education Foundation, Acworth, Georgia.

NCWM 2014 Interim Meeting: The NGSC suggested that the Committee Withdraw this item. The submitter of this item (who is also a member of the NGSC) submitted an alternative item in 2014 that was intended to replace this item. Consequently, the Committee decided to withdraw this item from its agenda.

Regional Association Comments:

The CWMA does not support the item as written and recommends the status remain as Developing. This is based on the lack of traceability for the conversion units proposed. It is suggested that the conversion units if accepted could be supplemental information. The majority of comments heard were in support of selling this product by a known mass (i.e., pounds or kilograms). In addition there was concern raised regarding the validity of the current CNG conversion units (GLE and GGE).

The WWMA heard no support on this item and recommended it be Withdrawn. The intent of the proposal is to make cost comparisons between diesel fuel and natural gas. The WWMA believes this proposal doesn't meet the historic definition of "Cost Comparison" and shouldn't be a specification item in NIST Handbook 44. The WWMA believes Natural Gas should be sold in traceable units and not artificial equivalent units. The NCWM Natural Gas Steering Committee should take into consideration global method of sale and advertising of LNG/CNG. The WWMA believes the urgency of this issue demands quick action by the NCWM because these devices are growing quickly in the marketplace.

NEWMA recommended that the item be Informational to give the Steering Committee time to work on the items and make suggestions.

SWMA heard comments in Open Hearing indicating that Item 337-5 was proposed to further clarify Item 337-4. The Committee agreed with comments heard that Item 337-4 continue to be a Developing Item. Based on the comments received, the Committee believed this item may be more appropriate as a user requirement and should be kept as developmental status with review by Steering Committee. The Committee believes the identity should be indicated in a single unit. The SWMA S&T and L&R Committees met jointly to discuss CNG and LNG items on both agendas.

See previous Reports of the National Conference on Weights and Measures for additional information on this item.

337-5 S.1.2. Compressed Natural Gas Dispensers, S.1.3.1.1. Compressed Natural Gas Used as an Engine Fuel, S.5.2. Marking of Gasoline Volume Equivalent Conversion Factor

The Committee considered the following proposal to modify multiple MFM specification paragraphs to recognize gasoline and diesel "equivalent" units for liquefied natural gas and compressed natural gas. This item (along with accompanying recommendations and background information) was consolidated with Item 337-2 as a result of action by the Committee at the 2014 NCWM Interim Meeting. See Item 337-2 for additional details.

As a result of June 12, 2014, discussions of the S&T Committee, in conjunction with NGSC recommendations, it became necessary to further clarify the status of Agenda Items 337-3 and 337-5. In March 2014, the Committee agreed with the NGSC's recommendation for modifications of the proposed NIST Handbook 44 requirements in these agenda items and their consolidation into a single Voting item under agenda Item 337-2. Consequently, the "V" (Voting) designation was removed from Agenda Items 337-3 and 337-5.

Source:

Clean Vehicle Education Foundation (2014)

Purpose:

Since natural gas is sold in the retail market place as compressed natural gas (CNG) to be an alternative fuel to gasoline and diesel fuel and as liquefied natural gas (LNG) to be an alternative fuel to diesel, the proposed additions and edits to NIST Handbook 44 will provide definitions for natural gas equivalents for diesel liters and diesel gallons so that end users can radially compare cost and fuel economy. At present only CNG equivalents for gasoline are included in the handbooks.

Item Under Consideration:

Amend NIST Handbook 44, Mass Flow Meters Code as follows:

S.1.2. Compressed Natural Gas and Liquefied Natural Gas Dispensers. – Except for **non-retail** fleet sales and other price contract sales, a compressed natural gas **and liquefied natural gas** dispensers used to refuel vehicles shall be of the computing type and shall indicate the quantity, the unit price, and the total price of each delivery. The dispensers shall display the mass measured for each transaction either continuously on an external or internal display accessible during the inspection and test of the dispensers, or display the quantity in mass units by using controls on the device.

(Added 1994)

S.1.3.1.1. Compressed Natural Gas Used as an Engine Fuel. – When **compressed** natural gas is dispensed as an engine fuel, the delivered quantity shall be indicated in: ~~“gasoline liter equivalent (GLE) units” or “gasoline gallon equivalent (GGE) units”~~ (see definitions).

(a) mass (in pounds or kilograms); or

(b) "gasoline liter equivalent (GLE) units" or "gasoline gallon equivalent (GGE) units;"

(c) "diesel liter equivalent (DLE) units" or "diesel gallon equivalent (DGE) units" (see definitions).

(Added 1994)

S.1.3.1.2. Liquefied Natural Gas Used as an Engine Fuel. – **When liquefied natural gas is dispensed as an engine fuel, the delivered quantity shall be indicated in:**

(a) Mass (in pounds or kilograms), or

(b) "diesel liter equivalent (DLE) units" or "diesel gallon equivalent (DGE) units" (see definitions).

S.5.2. Marking of Diesel and Gasoline Volume Equivalent Conversion Factor. – A device dispensing compressed-natural gas shall have: ~~either the statement “1 Gasoline Liter Equivalent (GLE) is Equal to 0.678 kg of Natural Gas” or “1 Gasoline Gallon Equivalent (GGE) is Equal to 5.660 lb of Natural Gas” permanently and conspicuously marked on the face of the dispenser according to the method of sale used.~~

(a) either the statement "1 Gasoline Liter Equivalent (GLE) is Equal to 0.678 kg of Natural Gas" or "1 Gasoline Gallon Equivalent (GGE) is Equal to 5.660 lb of Natural Gas",

(b) either the statement "1 Diesel Liter Equivalent (DLE) is Equal to 0.765 kg of Natural Gas" or "1 Diesel Gallon Equivalent (DGE) is Equal to 6.38 lb of Natural Gas"

(Added 1994)

S.5.3. Marking of Diesel Volume Equivalent Conversion Factor. – A device dispensing liquefied natural gas shall have: the statement "1 Diesel Liter Equivalent (DLE) is Equal to 0.7263 kg of Natural Gas" or "1 Diesel Gallon Equivalent (DGE) is Equal to 6.06 lb of Natural Gas" permanently and conspicuously marked on the face of the dispenser according to the method of sale used.

337-6 D Mass Flow Meters Code, S.3.6. Automatic Density Compensation

Source:

NCWM Natural Gas Steering Committee (2014 Interim Meeting)

Source:

This is a new item (2014) that originated from the NCWM Natural Gas Steering Committee (NGSC) as a result of its deliberations January through March 2014 on agenda Item 337-1 (an alternative proposal for defining and establishing legal metrology requirements for quantity indications and markings on a device when CNG and LNG are dispensed and sold as engine fuel in volume equivalent units). The NGSC recommends the proposal as a developing item to allow additional time for the NCWM NTEP Measuring Sector and Measuring Laboratories to fully vet the newly proposed modifications to NIST Handbook 44 Mass Flow Meters Code paragraph S.3.6. Automatic Density Correction.

Purpose:

Provide a starting point for work identified in March 2014 by the NGSC and S&T Committee that is necessary to fully address legal metrology requirements for LNG retail and wholesale applications.

Item Under Consideration:

Amend NIST Handbook 44 Mass Flow Meters Code paragraph S.3.6. as follows:

S.3.6. Automatic Density Correction.

- (a) An automatic means to determine and correct for changes in product density shall be incorporated in any mass flow metering system that is affected by changes in the density of the product being measured.
- (b) Volume-measuring devices with automatic temperature compensation used to measure **liquefied** natural gas as a motor vehicle engine fuel shall be equipped with an automatic means to determine and correct for changes in product density due to changes in the temperature, ~~pressure, and composition~~ of the product.

(Amended 1994 ~~and~~ 1997, **and 201X**)

Background/Discussion:

After the January 2014 NCWM Interim Meeting, the NGSC and S&T Committee received input from Mr. Dmitri Karimov (Liquid Controls Corporation, LLC and a member of the NGSC) who proposed to differentiate between CNG and LNG in the requirements of paragraph S.3.6 "Automatic Density Correction" when using volumetric devices. Mr. Karimov indicated that density calculations of LNG when measured using a volumetric device, require temperature determination only. CNG devices will not be allowed to use indirect mass measurement in Mr. Karimov's proposal.

Mr. Karimov's provided the NGSC and S&T Committee with the following points as rationale for the proposed changes to paragraph S.3.6.:

- The requirements for volume-measuring devices were developed in 1994 and 1997 for CNG based on hydrocarbon gas vapor code. See the attached NCWM final reports at the end of the document.
- The concerns might be valid for CNG but not for LNG. For LNG, only temperature input is required to calculate mass value.
- Based on the most recent changes to the Mass Flow Meters Code by the NGSC, indirect mass measurement is proposed to be allowed for LNG but not CNG, so S.3.6 needs to be modified.
- CNG and LNG mass flow meters (Coriolis) with automatic density correction will be covered by paragraph S.3.6.(a)
- LNG volume-measuring devices (such as orifice plate and turbine meters) will be covered by paragraph S.3.6.(b) since indirect mass measurement for CNG is no longer allowed under the proposal by the NGSC.
- CNG (being gas) is very compressible, so pressure is a significant influence factor in density calculation. "Pressure" was added to S.3.6.(b) in 1997 because at that time the paragraph was relied upon only for CNG.
- LNG, on the other hand, is measured at very low pressure, and – being liquid- is not compressible at the pressures at which it is measured. Pressure effect on density of LNG is therefore negligible. See the table below where Mr. Karimov generated data on LNG density changes using the NIST REFPROP database.
- Per documentation received by the NGSC from the Clean Vehicle Education Foundation, the composition of the natural gas remained virtually unchanged over the last 21 years. Therefore, volumetric devices for LNG could use fixed composition in density calculations as per ASTM D4784, Clause 2.1 (see below).
- Finally, indirect mass measurement volumetric devices undergo type evaluation, and only those devices meeting accuracy requirements through proper density calculations are approved.

Supporting documentation:

ASTM D4784 – 93 (Reapproved 2010) Standard Specification for LNG Density Calculation Models ASTM D4784 provides models for density calculation.

2. Significance and Use

2.1 The models in this specification can be used to calculate the density of saturated liquid natural gas in the temperature range 90 to 120 K. The estimated uncertainty for the density calculations is ± 0.1 %. The restrictions on composition of the liquefied natural gas are:

methane	60 % or greater
nitrogen	less than 4 %
<i>n</i>-butane	less than 4 %
<i>i</i>-butane	less than 4 %
pentanes	less than 2 %

Mr. Karimov also referenced excerpts from two previous Committee reports: 1) NIST SP 870 the 1994 Report of the 79th NCWM, Agenda Item 337-4B in the Final Report of the Specifications and Tolerances Committee; and 2) NIST SP 920 the 1997 Report of the 82nd NCWM, Agenda Item 337-2 in the Final Report of the Specifications and Tolerances Committee.

The following is the table Mr. Karimov generated on LNG density changes using the NIST REFPROP database. Mr. Karimov noted that density changes to LNG are negligible at 120 K with changes in pressure from the base pressure of 27.765 psi up to 200 psi.

Density Changes to LNG			
Temperature¹ (K)	Pressure (psia)	Density (lb_{MASS}/gal)	% Density Difference²
120	27.765	3.4208	0.000 %
120	30	3.4209	- 0.003 %
120	35	3.4213	- 0.015 %
120	40	3.4216	- 0.023 %
120	45	3.4219	- 0.032 %
120	50	3.4222	- 0.041 %
120	55	3.4225	- 0.050 %
120	60	3.4229	- 0.061 %
120	65	3.4232	- 0.070 %
120	70	3.4235	- 0.079 %
120	75	3.4238	- 0.088 %
120	80	3.4241	- 0.096 %
120	85	3.4245	- 0.108 %
120	90	3.4248	- 0.117 %
120	95	3.4251	- 0.126 %
120	100	3.4254	- 0.134 %
120	105	3.4257	- 0.143 %
120	110	3.4261	- 0.155 %
120	115	3.4264	- 0.164 %
120	120	3.4267	- 0.172 %
120	125	3.427	- 0.181 %
120	130	3.4273	- 0.190 %
120	135	3.4276	- 0.199 %
120	140	3.428	- 0.210 %
120	145	3.4283	- 0.219 %
120	150	3.4286	- 0.228 %
120	155	3.4289	- 0.237 %
120	160	3.4292	- 0.246 %
120	165	3.4295	- 0.254 %
120	170	3.4298	- 0.263 %
120	175	3.4302	- 0.275 %
120	180	3.4305	- 0.284 %
120	185	3.4308	- 0.292 %
120	190	3.4311	- 0.301 %

Density Changes to LNG			
Temperature¹ (K)	Pressure (psia)	Density (lb_{MASS}/gal)	% Density Difference²
120	195	3.4314	– 0.310 %
120	200	3.4317	– 0.319 %

¹120 K (– 153 °C) (– 243 °F)
²Percent difference in product (pure methane) density is based on calculated variations to the base pressure of 27.765 psi using NIST REFPROP

Initially, Mr. Karimov presented his proposal to his colleagues on the NGSC. During the NGSC’s deliberation on the Clean Vehicle Education Foundation’s proposed changes to other Mass Flow Meters Code paragraphs (see Agenda Item 337-1), the NGSC also considered Mr. Karimov’s proposal. The NGSC agreed to encourage further work beyond the current scope of their work on the CVEF’s proposals. Admittedly, many of the NGSC indicated not fully comprehending the technical rationale for the Mr. Karimov’s proposal. After discussions with the S&T Committee, both Committees agreed that the proposal should be vetted by the NCWM NTEP Measuring Sector and Measuring Laboratories to ensure the community understands the intent and impact of the proposed changes to paragraph S.3.6. Additionally, NIST, OWM plans to consult with its Cryogenics Group on the proposal. Based on its discussion with the S&T Committee, both Committees believe the proposal has merit and should be included in the S&T Interim Meeting report as a separate new item with Developing status.

2014 Annual Meeting: The Committee heard numerous comments suggesting the proposal remain in a Developing status. Ms. Juana Williams (NIST, OWM) commented that NIST, OWM agrees with other comments that additional review and development is needed on this proposal, particularly given the variation in composition of natural gas supplies. NIST, OWM also notes that previous S&T Committee work on this paragraph, including 1994 and 1997, should be considered. Consequently the Committee agreed to recommend this item remain Developing.

At its 2014 Annual Meetings, both CWMA and NEWMA supported continued development of this item.

On the 2014 NCWM Online Position Forum, one industry representative indicated opposition on this item with no additional comments. Emerson Process Management – Micro Motion maintains the position that further research is needed to establish with certainty the range of the possible variation of the composition and density of commercially traded Liquefied Natural Gas (LNG) before this proposed item can be considered as fully developed. Emerson provided the following input:

Emerson Process Management – MicroMotion:

The metrological validity of the proposal to convert measurements from volume measuring devices into mass units without the benefit of an automatic means to determine and correct for changes in product density due to changes in the pressure and composition of the product is fully dependent on the fundamental assumption that the composition and the associated density of commercially traded LNG will remain constant within tight limits. Because this assumption is so essential to the proposed item, all possible sources of information about the current and future potential for variability of LNG composition and density should be considered.

NCWM has recognized that the measurement of LNG is different from that of other cryogenic fluids primarily because of the uncertainty of its composition. This conclusion dates back to discussions that began when a tentative code for cryogenic liquid-measuring devices was introduced in the 1972 Report of the Committee on Specifications and Tolerances. These discussions eventually led to LNG being specifically excluded from Section 3.34. Cryogenic Liquid-Measuring Devices, as stated in paragraph A.2.

A.2. Exceptions – This Code does not apply to the following:

(c) Devices used solely for dispensing liquefied natural gas.

There is evidence to suggest that the composition of LNG can vary significantly enough to change the density by an amount that would result in errors far greater than the allowable tolerance if there is no correction made when converting from volume to mass units. As one example, on February 11, 2005, the Gas Technology Institute (GTI) issued data on LNG density in Table 3 (see attachment) of the Natural Gas Composition and Fuel Quality Information Report that indicates the specific gravity of LNG can vary by as much as 12 %. The error in specific gravity in terms of percent translates directly to an equivalent percent error in mass flow indication if density changes due to composition are not accounted for.

Furthermore, an understanding of past variability in LNG composition is not sufficient to ensure that variations of LNG composition will remain constant in the future. This new provision could create an incentive to manipulate LNG composition in order to influence measurement results in favor of one party or another in commercial transactions. Therefore, ongoing assurance of LNG composition within strict limits through enforcement would be needed to eliminate the facilitation of fraud when using volume-measuring devices to measure LNG without the benefit of an automatic means to determine and correct for changes in product density due to changes in the composition. To be considered fully developed, the proposed item should include the specific requirements for LNG composition that must be enforced whenever volume devices are uncorrected for composition changes in order to prevent the manipulation of LNG composition beyond the prescribed limits and thus ensure that the converted volume errors are within the mass measurement tolerances.

A proposed method or methods for verification of the composition and density of LNG samples must be included to complete the development of this item in order to offer jurisdictions at least one practical method to accomplish the enforcement of these LNG composition requirements for installations where volume measurements are converted into mass units without the benefit of an automatic correction for changes in product density due to changes in the composition of the product.

Finally, pressure is a variable that can be controlled by the design and operation of most delivery systems. Eliminating the requirement to include correction of volume measuring devices for changes in product density due to changes in the pressure of the product would introduce the opportunity for manipulation of the measurement results in favor of one party by adjusting system pressure. Although the effect of pressure on LNG density is relatively small, because pressure is a variable that can be easily controlled rather than random, it would be necessary to record and monitor system pressure in between inspections to prevent intentional manipulation of system pressures for the purpose of creating predominance in favor one party.

354 TAXIMETERS

354-1 D USNWG on Taximeters – Taximeter Code Revisions and Global Positioning System-Based Systems for Time and Distance Measurement

Note: This item was originally titled “Item 360-5, S.5. Provision for Security Seals” in the Committee’s 2013 Interim Agenda. At the 2013 NCWM Interim Meeting, the Committee combined that item with “Item 354-1, Global Positioning Systems for Taximeters” and “Item 360-6, Global Positioning Systems for Taximeters” to create this new, consolidated item to address the development of recommendations on multiple topics related to taximeters and GPS-based time and distance measuring systems.

Source:

NIST USNWG on Taximeters

Purpose:

Develop recommendations for modifying the existing Taximeters Code to reflect current technology (including requirements for sealing, display requirements, and other features) and to examine GPS-based time and distance

measuring systems to determine how to best address these measuring systems in NIST Handbook 44 to ensure accuracy and transparency for passengers and businesses.

Item Under Consideration:

This item is under development. Comments and inquiries may be directed to Mr. John Barton (NIST, OWM) at (301) 975-4002 or john.barton@nist.gov.

The USNWG is considering proposals to modify the sealing requirements in the Taximeters Code to reflect more advanced sealing methods (see 2012 NCWM Final S&T Report); to amend the Taximeters Code to specifically recognize GPS-based time and distance measuring systems; and to amend other Sections of the Taximeters Code to reflect current technology and business practices while ensuring accuracy and transparency for customers and a level playing field for transportation service companies.

Background/Discussion:

The Committee has received multiple proposals over the past several years related to updating the current NIST Handbook 44 Taximeters Code to reflect current technology as well as a request to establish criteria for GPS-based time and distance measuring systems. In April 2012, NIST, OWM established a U.S. National Working Group (USNWG) to work on these issues. The USNWG has met multiple times since it was established. For details of those meetings as well as the current proposals being developed by the USNWG, please contact Mr. Barton as noted in the “Item Under Consideration” above.

Additional information and background on this item can be found in the Committee’s 2013 and earlier final reports.

NCWM 2014 Interim Meeting: NIST, OWM provided an update regarding progress of the USNWG. The USNWG is conducting meetings on a regular basis to continue its work in updating the existing NIST Handbook 44 Taximeters Code. Numerous sections of the current Code are based on older technologies and may not reflect the more recent advances seen in this area. While there are no specific proposed changes to the Taximeters Code at this time, it is anticipated that some proposals will be submitted prior to the next cycle of regional meetings in 2014. Some of the proposed changes that are expected will affect requirements concerning: the need for a recording element within a system; the advancement of indications; information included on receipts; the display of customer’s indications; and the use of GPS systems as a source of distance/time measurements. The next meeting of the USNWG is March 4, 2014. The Committee supports the efforts of the USNWG and looks forward to receiving proposed changes in the future.

During the 2014 NCWM Annual Meeting NIST, OWM provided the following update concerning this item:

The most recent meetings of the USNWG on Taximeters were held in March and May 2014. These meetings focused on the development of proposed changes to the NIST Handbook 44 Taximeters Code, which include:

- Changes to requirements regarding recording elements and passenger receipts;
- Amendments to requirement pertaining to the Code application;
- Specification requirements to passenger dedicated displays;
- Changes to the requirement regarding the basis of fare calculation; and
- Requirements to set parameters for the use of multiple rates in the calculation of fares.

The next meeting is scheduled for Thursday, August 7, 2014, when the USNWG will continue the development of proposed changes to NIST Handbook 44. The USNWG has developed a number of proposals that will be submitted for consideration by the S&T Committees of the Regional Weights and Measures Associations this fall. Subsequent meetings of the USNWG are planned every other month using web-conferencing to accommodate the many members who are unable to travel.

CWMA did not receive any comments from the floor on this item during their 2013 Interim Meeting and 2014 Annual Meeting. CWMA encouraged the continued work of the USNWG and reported that it looked forward to continued developments in this area and recommended that the item remain as a Developing item.

WWMA believes this item is still developing and more information is needed in the meter display and receipt requirements. More information is also needed in determining the accuracy of GPS and cell phone technology. WWMA recommended that the item remain as a Developing Item.

At their 2013 fall Interim Meeting, NEWMA reported that it recognized the USNWG on Taximeters has the task of updating a code from 1970's to reflect current technology. The USNWG still needs time to work on developments to this item so it is recommended the item remain a developing item. At their 2014 Annual Meeting, NEWMA reported that it supports further development of the Taximeter Code to address new technologies existing in the marketplace.

SWMA did not receive any comments received on this item. The SWMA supported further development by the USNWG on Taximeters.

See previous Reports of the National Conference on Weights and Measures for additional information on this item.

358 MULTIPLE DIMENSION MEASURING DEVICES

358-1 D Measurement of Bulk Material in Open-Top Truck and Trailer Units

Source:

LoadScan US (2014)

Purpose:

Develop a standardized testing protocol for a non-contact volumetric measurement instrument designed to measure loads of bulk loose solids in open-top truck and trailer units.

Item Under Consideration:

Develop new language for type classification, accuracy classification, and test methodology for load volume scanning devices.

Background/Discussion:

Laser technology allows for accurate volume measurement of bulk materials loaded on open-top truck and trailer bodies. Standard industry practice is to count loader buckets or convert from weight, both highly variable and inaccurate ways of measuring cubic volume. See Appendix F for detail on Load Scanner Metrology, Test Methods and Suitability for Use.

Contacts: Mr. Peter Russell (LoadScan US) (603) 831-6014 or peter.russell@loadscan.us and Mr. Adrian Ruthe (Loadscan Ltd.) +64 7-847-5777 or adrian@loadscan.com.

NCWM 2014 Interim Meeting: Mr. Peter Russell (LoadScan, Ltd.) and Mr. Adrian Ruthe (LoadScan, Ltd.) provided a joint presentation regarding the operation of a device that uses a scanner to measure the volume of product loaded into open-top truck and trailer units. Mr. Russell and Mr. Ruthe indicated that they were not familiar with the procedures of how to go about adding new requirements into NIST Handbook 44; nor did they know where in NIST Handbook 44, requirements intended to apply to their equipment would best fit. They asked the Committee for guidance on how best to proceed concerning these issues.

The Committee acknowledged there is not yet a specific proposal to consider and additional information and input is needed for the development of this item. The Committee agreed to designate this item as a "Developing" item on its agenda to allow time for the issue to be further developed by the submitter. The Committee noted a specific

proposal outlining recommended changes to NIST Handbook 44 is needed in order for the item to advance through the process.

While the Committee is not certain if the MDMD Code is the most appropriate code for addressing these devices, the Committee suggested the MDMD Work Group might be willing to consider this issue and provide input on further development of draft NIST Handbook 44 language. Alternatively, or in addition, the submitter may wish to contact the NTEP Weighing Sector to determine if that Sector or its' members might be able to provide additional assistance.

The Committee received a document from the submitter (titled "Load Volume Scanner, Proposals for Integration into NIST Handbook 44") that provides additional information and supporting arguments for addressing this issue, along with some recommended changes to NIST Handbook 44. The Committee has included this document in Appendix G of this report and encourages interested parties to provide input to the submitter.

2014 NCWM Annual Meeting: Mr. Rick Harshman (NIST Technical Advisor) reported that he had recently contacted LoadScan Ltd. to determine if there had been any further development of the item since the 2014 NCWM Interim Meeting and was provided the following update from Mr. Ruthe:

LoadScan Ltd. in New Zealand is aware that the NCWM Annual Meeting is coming up. Unfortunately, the reality is we have not had the resources to be able to pursue our case this year and will not be making any submissions at the moment. We plan to engage the services of local experts within the USA to pursue this matter for us over the next year. We are also completing further background work with weights & measures authorities in New Zealand and Australia which we hope will support our drive for approval in the USA. At this state we request only to retain our "Developing Item" status.

The Committee agreed to retain the "Developing" status of the item based on the update provided by the submitter of the item and his request to do so.

At their 2014 spring meeting, CWMA supported the continued development of this item.

NEWMA reported at their 2013 Interim Meeting that it would like to see the submitter move forward with further development of this new item to explore the feasibility of this item in NIST Handbook 44. During their 2014 Annual Meeting, NEWMA recommended the item remain "Developing" until such time that the manufacturer of the equipment can provide supporting documentation relative to the performance of the device. The item also needs to be developed to address test standards, test methods, and draft language for NIST Handbook 44.

SWMA received a presentation but heard no additional comments in its Open Hearings. The submitter did have questions from members about the device itself, but there were not any comments on the item. Based on this, the SWMA recommended the item continue to be developed. SWMA forwarded the item to NCWM.

360 OTHER ITEMS

360-1 D International Organization of Legal Metrology (OIML) Report

Many issues before the OIML, the Asian-Pacific Legal Metrology Forum, and other international groups are within the purview of the Committee. The Committee has maintained an item on its report as a means of keeping NCWM members abreast of these activities, and NIST, OWM has regularly provided an update as part of this item. In recent years, rather than providing separate reports to individual Committees, NIST, OWM has begun providing a single update of activities relative to all NCWM Committees in conjunction with the Board of Directors' agenda. The Committee believes that this is the most efficient approach to keep members abreast of these activities, and based on discussions with NIST, OWM, the Committee plans to eliminate this item from its agenda beginning with the next NCWM cycle. The Committee will include a note in the preamble to its report referencing the OIML report that is provided as part of the Board of Directors' Report so that those interested in these activities can locate this information.

Additional information on OIML activities will continue to appear in the Board of Directors agenda and Interim and Final Reports and on the OIML website at www.oiml.org. NIST, OWM staff will continue to provide the latest updates on OIML activities during the BOD's Open Hearings at NCWM meetings. For more information on specific OIML related device activities, contact the NIST, OWM staff listed in the table below. The list below of OIML projects only represents active projects.

NIST Office of Weights and Measures Staff Contact List for International Activities	
Contact Information	Responsibilities
Mr. John Barton –LMDP Phone: (301) 975-4002 Email: john.barton@nist.gov	<ul style="list-style-type: none"> • R 21 <i>Taximeters</i> • R 50 <i>Continuous Totalizing Automatic Weighing Instruments (Belt Weighers)</i> • R 60 <i>Metrological Regulations for Load Cells</i> • R 106 <i>Automatic Rail-weighbridges</i>
Mr. Kenneth Butcher –LMP Phone: (301) 975-4859 Email: k.butcher@nist.gov	<ul style="list-style-type: none"> • TC 6 <i>Prepackaged Products</i>
Dr. Charles Ehrlich –ILMP Phone : (301) 975-4834 Email : charles.ehrlich@nist.gov	<ul style="list-style-type: none"> • International Committee of Legal Metrology Member for the United States • V1 <i>International Vocabulary of Terms in Legal Metrology</i> • V2 <i>International Vocabulary of Basic and General Terms in Metrology</i> • B 3 <i>OIML Certificate System for Measuring Instruments</i> • B 6 <i>OIML Directives for the Technical Work</i> • B 10 <i>Framework for a Mutual Acceptance Arrangement on OIML Type Evaluations</i> • TC 3/SC 5 <i>Expression of Uncertainty in Measurement in Legal Metrology Applications, Guidelines for the Application of ISO/IEC 17025 to the Assessment of Laboratories Performing Type Evaluation Tests</i> • TC 3 <i>Metrological Control</i> • ISO/IEC <i>Guide to the Expression of Uncertainty in Measurement</i>
Mr. Richard Harshman –LMDP Phone: (301) 975-8107 Email: richard.harshman@nist.gov	<ul style="list-style-type: none"> • R 51 <i>Automatic Catchweighing Instruments</i> • R 61 <i>Automatic Gravimetric Filling Instruments</i> • R 76 <i>Non-automatic Weighing Instruments</i> • R 107 <i>Discontinuous Totalizing Automatic Weighing Instruments (totalizing hopper weighers)</i> • R 134 <i>Automatic Instruments for Weighing Road Vehicles In-Motion and Measuring Axle Loads</i>
Ms. Diane Lee –LMDP Phone: (301) 975-4405 Email: diane.lee@nist.gov	<ul style="list-style-type: none"> • R 59 <i>Moisture Meters for Cereal Grains and Oilseeds</i> • R 92 <i>Wood Moisture Meters – Verification Methods and Equipment</i> • TC 17/SC 8 <i>Protein Measuring Instruments for Cereal Grains and Oil Seeds</i>

NIST Office of Weights and Measures Staff Contact List for International Activities			
Contact Information		Responsibilities	
Mr. Ralph Richter –ILMP Phone: (301) 975-3997 Email: ralph.richter@nist.gov		<ul style="list-style-type: none"> • D 11 <i>General Requirements for Measuring Instruments – Environmental Conditions</i> • R 35 <i>Material Measures of Length for General Use</i> • R 49 <i>Water Meters (Cold Potable Water and Hot Water Meters)</i> • R 71 <i>Fixed Storage Tanks</i> • R 80 <i>Road and Rail Tankers (static measurement)</i> • R 85 <i>Automatic Level Gauges for Measuring the Level of Liquid in Fixed Storage Tanks</i> • R 95 <i>Ship’s Tanks</i> • R 117 <i>Measuring Systems for Liquids Other Than Water (all measuring technologies)</i> • R 118 <i>Testing Procedures and Test Report Format for Pattern Examination of Fuel Dispensers for Motor Vehicles</i> • TC 3/SC 4 <i>Verification Period of Utility Meters Using Sampling Inspections</i> • R 137 <i>Gas Meters (all measuring technologies)</i> • R 140 <i>Measuring Systems for Gaseous Fuel (i.e., large pipelines)</i> • ISO TC 30/SC 7 <i>Water Meters</i> 	
Dr. Ambler Thompson –ILMP Phone: (301) 975-2333 Email: ambler@nist.gov		<ul style="list-style-type: none"> • V1 <i>International Vocabulary of Terms in Legal Metrology</i> • D 16 <i>Principles of Assurance of Metrological Control</i> • D 19 <i>Pattern Evaluation and Pattern Approval</i> • D 20 <i>Initial and Subsequent Verification of Measuring Instruments and Processes</i> • D 27 <i>Initial Verification of Measuring Instruments Using the Manufacturer’s Quality Management System</i> • D 31 <i>General Requirements for Software Controlled Measuring Instruments</i> • R 34 <i>Accuracy Classes of Measuring Instruments</i> • R 46 <i>Active Electrical Energy Meters for Direct Connection of Class 2</i> 	
Ms. Juana Williams –LMDP Phone: (301) 975-3989 Email: juana.williams@nist.gov		<ul style="list-style-type: none"> • R 81 <i>Dynamic Measuring Devices and Systems for Cryogenic Liquids</i> • R 139 <i>Compressed Gaseous Fuels Measuring Systems for Vehicles</i> 	
List of Acronyms			
B	Basic Publication	LMDP	Legal Metrology Devices Program
CIML	International Committee of Legal Metrology	P	Project
D	Document	R	Recommendation
ILMP	International Legal Metrology Program	SC	Subcommittee
LMP	Laws and Metrics Program	TC	Technical Committee

Contact Point: See contacts listed in the table above for specific technical areas.

Regional Association Comments:

CWMA supports the work of OIML and suggests this remain as a Developing item.

WWMA thanks NIST for their work in the International arena and looks forward to future updates. FYI, the next OIML meeting will be in Vietnam in 2013. The WWMA recommended that the item remain as a Developing item.

NEWMA recognized the importance of this item and recommended that it remain as a Developing item.

SWMA did not receive comments on this item and recommended further development. The SWMA continues to support these issues.

See previous Reports of the National Conference on Weights and Measures for additional information on this item.

360-2 D Appendix D – Definitions: Remote Configuration Capability

Source:

NTEP Grain Analyzer Sector (2013)

Purpose:

Expand the scope of definition to cover instances where the “other device,” as noted in the current definition, may be necessary to the operation of the weighing or measuring device, or which may be considered a permanent part of that device.

Item Under Consideration:

This item is under development. Comments and inquiries may be directed to NIST Office of Weights and Measures.

A proposal to modify the definition for “remote configuration capability” as follows is under consideration:

remote configuration capability. – The ability to adjust a weighing or measuring device or change its sealable parameters from or through some other device that ~~is not~~ **may or may not** itself **be** necessary to the operation of the weighing or measuring device or ~~is not~~ **may or may not be** a permanent part of that device.[2.20, 2.21, 2.24, 3.30, 3.37, 5.56(a)]

(Added 1993) (**Amended 20XX**)

Background/Discussion:

Removable digital storage devices can be used in GMMs as either data transfer devices that are not necessary to the operation of the GMM or as data storage devices which are necessary to the operation of the GMM. If removable data storage devices are necessary to the operation of the device, they are not covered by the current definition of remote configuration capability.

A USB flash drive is most likely to be used as a data transfer device. In a typical data transfer application, the USB flash drive is first connected to a computer with access to the GMM manufacturer’s web site to download the latest grain calibrations that are then stored in the USB flash drive. The USB flash drive is removed from the computer and plugged into a USB port on the GMM. The GMM is put into remote configuration mode to copy the new grain calibration data into the GMM’s internal memory. When the GMM has been returned to normal operating (measuring) mode, the USB flash drive can be removed from the GMM.

Although a Secure Digital (SD) memory card could also be used as a data transfer device, it is more likely to be used as a data storage device. In a typical “data storage device” application, the SD memory card stores the grain calibrations used on the GMM. The SD memory card must be plugged into an SD memory card connector on a GMM circuit card for the GMM to operate in its measuring mode. To install new grain calibrations, the GMM must be turned “off” or put into a mode in which the SD memory card can be safely removed. Either the SD memory card can be replaced with an SD memory card that has been programmed with the new grain calibrations or the original SD memory card can be re-programmed with the new grain calibrations in much the same way as that described in the preceding paragraph to copy new grain calibrations into a USB flash drive. In either case, the SD memory card containing the new calibrations must be installed in the GMM for the GMM to operate in measuring

mode. In that regard, the SD memory card (although removable) can be considered a permanent part of the GMM in that the GMM cannot operate without it.

Note: In the above example, SD memory card could be any removable flash memory card such as the Secure Digital Standard-Capacity, the Secure Digital High-Capacity, the Secure Digital Extended-Capacity, and the Secure Digital Input/Output, which combines input/output functions with data storage. These come in three form factors: the original size, the mini size, and the micro size. A “Memory Stick” is a removable flash memory card format launched by Sony in 1998, and is also used in general to describe the whole family of Memory Sticks. In addition to the original Memory Stick, this family includes the Memory Stick PRO, the Memory Stick Duo, the Memory Stick PRO Duo, the Memory Stick Micro, and the Memory Stick PRO-HG.

Grain Analyzer Sector 2011 Meeting: The Sector agreed by consensus that the following changes to Table S.2.5. of Section 5.56.(a) of NIST Handbook 44 should be forwarded to the S&T Committee for consideration:

- Add a note to Table S.2.5. to recognize the expanded scope of remote capability.
- Delete “remotely” from the second paragraph of Category 3 requirements that begins, “When accessed remotely ...” to make it clear that the requirements of Category 3 apply whether accessed manually using the keyboard or accessed by remote means.
- Add the modified second paragraph of Category 3 requirements to Categories 3a and 3b to make it clear that these requirements apply to all the subcategories of Category 3.

Because a change to the definition of remote configuration capability will apply to other device types, NIST, OWM recommended that the changes to Table S.2.5. approved by the Sector in 2011 be separated into two independent proposals. One proposal would deal with the changes to Category 3 and its subcategories. The second would recommend a modification of the definition of “remote configuration capability” appearing in Appendix D of NIST Handbook 44 to recognize the expanded scope of remote capability; this proposal would be an alternative to adding a note to the bottom of Table S.2.5. to expand the definition for remote configuration for grain moisture meters (as shown in this proposal).

At its 2012 Meeting, the Grain Analyzer Sector agreed to separate its original proposal into two separate proposals and agreed to forward this proposal to change the definition of “remote configuration capability” to the S&T Committee for consideration. See also August 2012 NTEP Grain Analyzer Sector Summary, Item 5.

In 2013, NIST, OWM reported that it recognized the current definition for “remote configuration capability” may not address those grain moisture meters (GMMs) which can only be operated with a removable data storage device, containing, among other things, the grain calibrations intended for use with the GMM, inserted in the device (as was described by the Grain Analyzer Sector). As such, NIST, OWM noted that current sealing requirements were developed at a time when such technology likely didn’t exist, nor could be envisioned, and are based on the current definition of remote configuration capability. Because the current definition was never intended to apply to this “next generation” technology, NIST, OWM suggested that those charged with further development of this item may wish to revisit the five philosophies of sealing and consider whether a new paragraph, completely separate from current sealing requirements, might be appropriate and a better option, than the one currently proposed. The five philosophies of sealing are included in the 1992 Report of the 77th National Conference on Weights and Measures (Report of the Specifications and Tolerances Committee). Another option, preferred over the changes currently proposed, would be to add a separate statement to the current definition of “remote configuration capability” to address removable storage devices. For example, the following sentence might be considered as an addition to the current definition for “remote configuration capability:”

Devices which are programmed using removable media (such as SD cards, flash drives, etc.) that may or may not be required to remain with the device during normal operation are also considered to be remotely configured devices.

NIST, OWM also reported that it planned to develop draft language and ask for input from the various Sectors at their upcoming meetings.

Additional information and background on this item can be found in the Committee's 2013 final report.

NCWM 2014 Interim Meeting: The SMA indicated that the language in the "Item Under Consideration" is acceptable.

The Committee received comments from the Measuring Sector indicating opposition to the proposed language and suggesting that the current definition is adequate. The Committee also heard comments from NIST, OWM expressing concern that the proposed language does not clearly define when a device is considered "remotely configurable." NIST, OWM noted that it is continuing to develop this issue and has approached the various NTEP Sectors for additional input regarding the capabilities of new technology with regard to metrologically significant adjustments. During their 2013 meeting, the Weighing Sector asked its members to assist NIST, OWM in identifying the various types of removable storage media used in weighing equipment.

The Committee acknowledged comments from NIST, OWM expressing concern that the issue be carefully considered to avoid unintentional consequences. The Committee agreed to maintain the Developing status of item in consideration of the ongoing work of NIST, OWM to further develop this item.

NCWM 2014 Annual Meeting: NIST, OWM commented that it does not believe the proposed changes to the definition of "remote configuration capability" are appropriate, but doesn't have an alternative to offer at this time. NIST, OWM plans to continue work on this item after the 2014 NCWM Annual meeting. The Committee again agreed to maintain the Developing status of item in consideration of the ongoing work of NIST, OWM to further develop this item.

The SMA supported the intent of the item and looked forward to further clarification of the requirements.

CWMA agreed in 2013 that remote configuration capability may need to be addressed in the General Code and supported this as a Developing Item at both the 2013 CWMA Interim Meeting and 2014 CWMA Annual Meeting.

WWMA believes this item needs further development and should consider the effects on other device types. WWMA encourages NIST, OWM to develop draft language and ask for input from various Sectors at their upcoming meetings. The WWMA recommended that the item remain as a Developing Item.

NEWMA members were encouraged by NIST at the 2013 NCWM Annual Meeting to consider this work as it applies to all device types. NEWMA supported this item as a Developing Item in 2013 and 2014.

SWMA did not receive comments on this item and recommended further development.

See previous Reports of the National Conference on Weights and Measures for additional information on this item.

360-3 D Electric Vehicle Fueling and Submetering

Source:

California Department of Food and Agriculture Division of Measurement Standards (2014)

Purpose:

Keep the weights and measures community apprised of work to develop standards for Electric Vehicle Fueling and Submetering (EVF&S) and to encourage their participation in this work.

Item Under Consideration:

The U.S. National Work Group (USNWG) for Electric Vehicle Fueling and Submetering is developing proposed specifications, tolerances, and other technical requirements for Electric Vehicle Fueling and Submetering Systems for inclusion in NIST Handbook 44. The code currently under development by the USNWG is included in

Appendix H; however, this draft is NOT yet ready for consideration by the NCWM. The USNWG plans to complete revisions to this document and submit a final draft version to the regional weights and measures associations by fall 2014.

Background/Discussion:

In 2013, the NCWM adopted a uniform method of sale for retail electrical energy sold as a vehicle fuel. Adding specifications, tolerances, and other technical requirements for equipment that measures electricity as a motor fuel are necessary to provide consumer confidence that measurement of electricity is accurate and that there is sufficient information for the selection of charging equipment, (Levels I, II, and III), and price to pay.

The USNWG EVF&S discussed a number of challenges to field inspection and testing of EVSE systems. Utility companies and at least one U.S. Weights and Measures jurisdiction have established test procedures and test equipment specifications for utility-type and submetering electrical energy metering applications.

The USNWG EVF&S was formed to develop proposed requirements for commercial electricity-measuring devices (including those used to measure and sell electricity commercially delivered as vehicle fuel and those used in submetering electricity at residential and business locations) and to ensure that the prescribed methodologies and standards facilitate measurements that are traceable to the International System of Units (SI).

The “West Coast Electric Highway” is a project with an extensive network of electric vehicle DC fast charging stations located every 25 miles to 50 miles along Interstate 5 and other major roadways in the Pacific Northwest. In California alone, there are currently 1387 electric charging stations and over one million plug-in electric vehicles (PEV) are projected to be on California roads by 2020. The development of standards for PEV charging equipment is needed to provide consumers with fueling experiences and expectations similar to those at traditional gasoline dispensers.

Additionally, these standards, once they are developed and adopted, will be used to provide training and education to weights and measures officials about testing and regulating these devices, and support uniform standards and enforcement of these standards throughout the United States.

See Appendix H for a Tentative Code being considered by the USNWG EVF&S.

NCWM 2014 Interim Meeting: Ms. Juana Williams (NIST, OWM), Technical Advisor to the USNWG EVF&S reported that the USNWG met two weeks prior to the Interim Meeting and is continuing work on a draft code for eventual inclusion in NIST Handbook 44. Ms. Williams emphasized that because the USNWG has additional work to complete on various portions of the draft code, the draft is not ready for consideration by the NCWM. The draft included in NCWM Publication 15 has been revised and will be made available on the NIST, OWM web site. The USNWG will hold several meetings over the next six months and plans to submit a final draft in fall 2014.

Ms. Tina Butcher (NIST, OWM), Chairman of the USNWG, asked that state and local jurisdictions provide contact information of appropriate personnel from their corresponding public utility to assist the WG in identifying specific requirements that apply to EVSE in their jurisdictions.

The Committee acknowledged the need for EVSE Industry to participate in the NCWM process. This need was also expressed through comments heard during the Open Hearings. The Committee heard additional comments from a member of the WG who noted that a limited number of weights and measures officials are members of the WG and encouraged more to participate.

The Committee agreed forward to further work by the USNWG and agreed to designate this as a Developing item.

NCWM 2014 Annual Meeting: Ms. Butcher provided a short presentation updating the NCWM membership on the progress of the USNWG in developing a draft code. Mrs. Butcher’s presentation provided an overview of:

- the types of commercial electric vehicle fueling equipment;

- key objectives of the USNWG;
- the method of sale requirements that were adopted in 2013;
- the development of device requirements; and
- the test equipment that will be needed and the test procedures that will likely need to be applied to verify device performance.

Ms. Butcher advised that the USNWG is developing separate draft codes for proposed inclusion in NIST Handbook 44: one code to address electric vehicle refueling and one code to address other submetering applications subject to regulation by weights and measures jurisdictions. The USNWG plans to have the draft code for electric vehicle refueling systems ready for submission to the fall 2014 regional weights and measures associations with a request that the regional associations consider recommending it for a vote in the 2015 cycle. The USNWG hopes that the Committee will consider designating this item as a Voting item in January 2015 and recommend the draft code for adoption in July 2015. As also noted during Ms. Butcher's presentation, the USNWG will continue its work to finalize recommended requirements and test procedures for this equipment.

The Committee also heard a number of comments from regulatory officials in appreciation of the work NIST, OWM and others had done thus far in developing the draft code while also acknowledging the need to have such a standard in place to be able to inspect and test such equipment.

The Committee agreed to maintain the "Developing" status of this item and looks forward to the completion of a draft code by the USNWG.

Regional Association Comments:

Interim 2013 Meeting and 2014 Annual Meeting: The CWMA agreed to forward the item to NCWM recommending it as a Developing item.

Annual 2014 Meeting: NEWMA recommended maintaining the Developing status of this item and reported that it supports the ongoing work of the WG.

The WWMA recognized that the draft tentative Code is still under development by the USNWG. The WWMA recommends all jurisdictions review the draft tentative Code and provide comments to the WG. The WWMA recommended that the item remain as a Developing Item.

SWMA did not receive any comments. The SWMA recommends the item remain as a Developing Item. The SWMA forwarded the item to NCWM.

Mr. Brett Gurney, Utah | Committee Chair
Mr. Mahesh Albuquerque, Colorado | Member
Ms. Jane Zulkiewicz, Town of Barnstable, MA | Member
Dr. Matthew Curran, Florida | Member
Mr. Ivan Hankins, Iowa | Member
Mr. Luciano Burtini, Measurement Canada | Canadian Technical Advisor
Ms. Tina Butcher, NIST, OWM | NIST Technical Advisor
Mr. Rick Harshman, NIST, OWM | NIST Technical Advisor

Specifications and Tolerances Committee

This page intentionally left blank

Appendix A

NIST Handbook 44 – Scales

Item: 320-2:

UR.2.4. Foundations, Supports, and Clearance

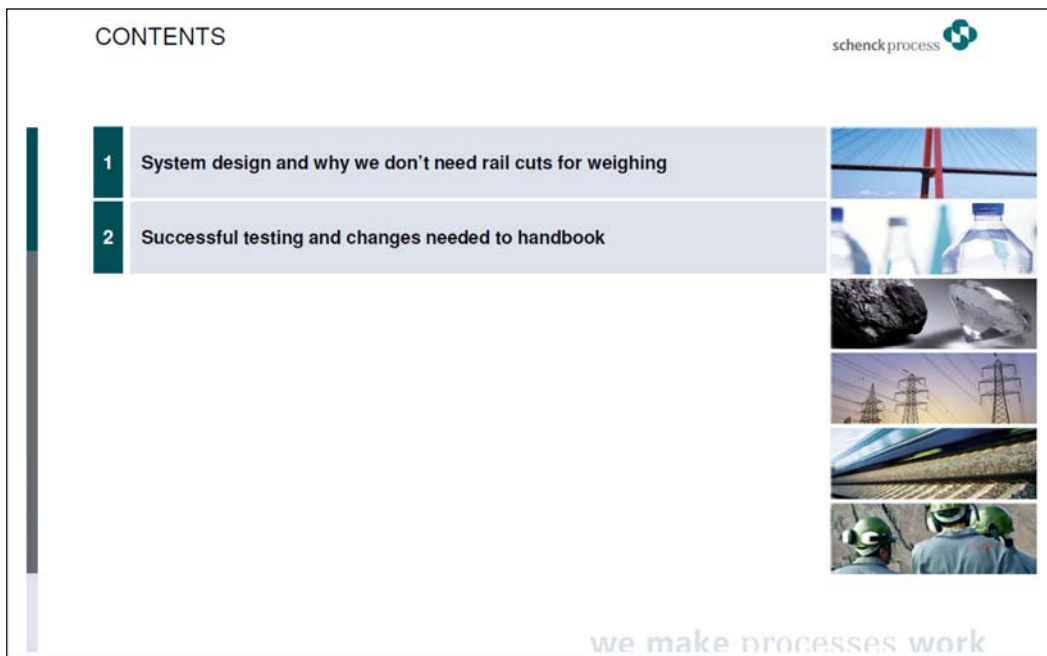

schenck process 

1 System design and why we don't need rail cuts for weighing



we make processes work

© Schenck Process 2012

3

MULTIRAIL LEGALWEIGHT DESIGN

schenck process 

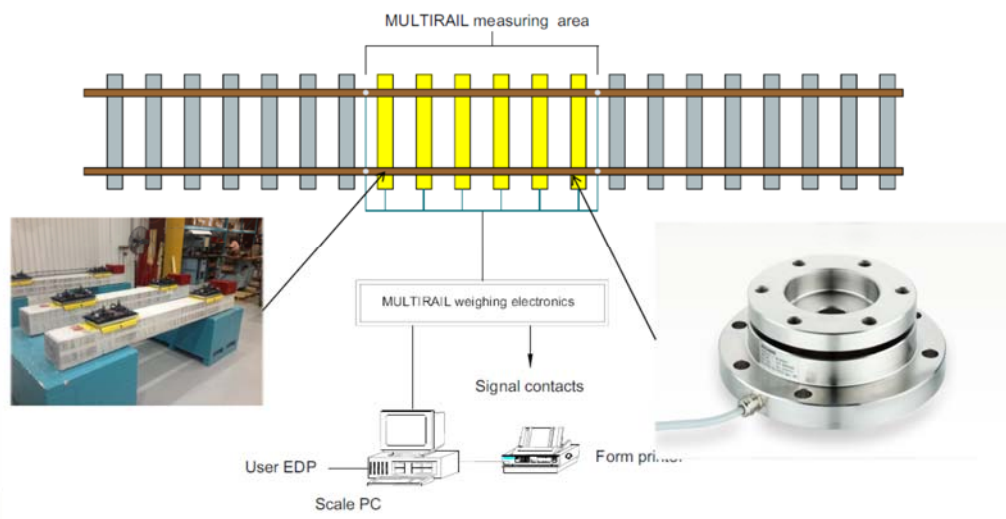

MULTIRAIL measuring area

MULTIRAIL weighing electronics

Signal contacts

User EDP

Scale PC

Form printer

we make processes work

© Schenck Process 2012

4

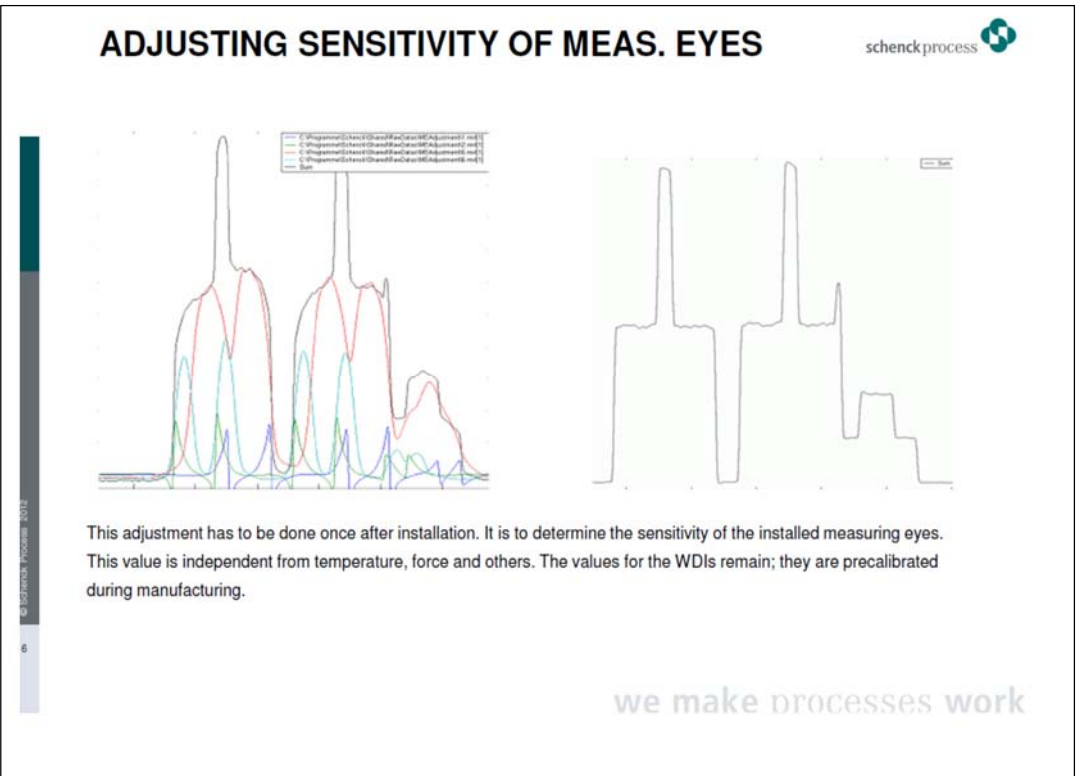
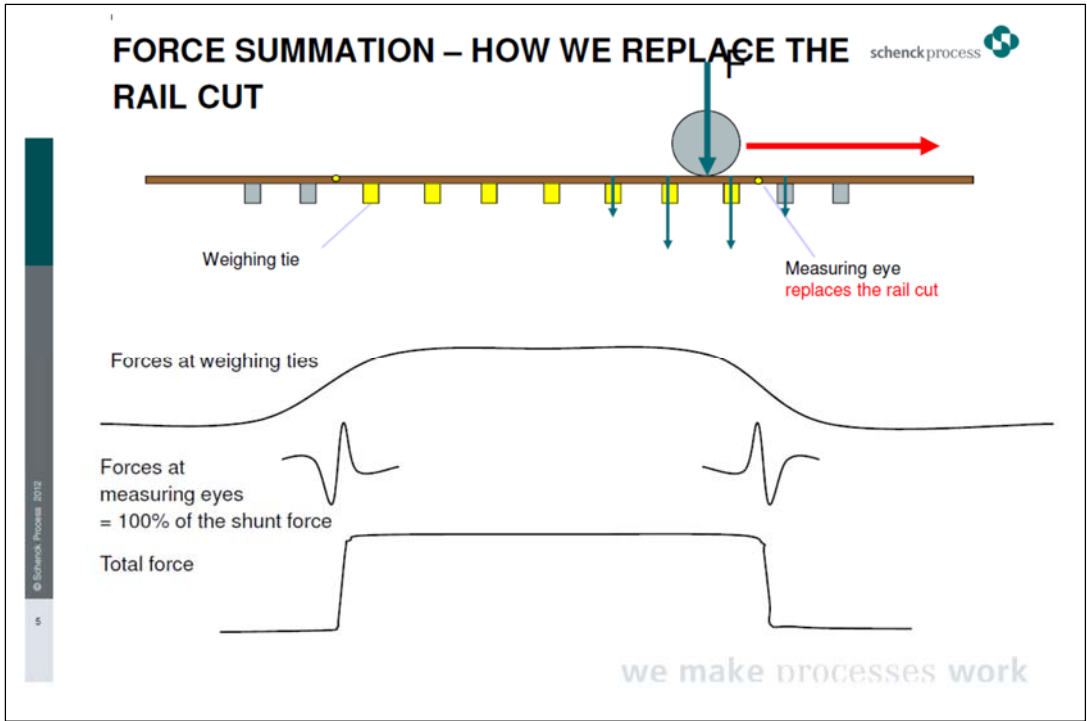

This adjustment has to be done once after installation. It is to determine the sensitivity of the installed measuring eyes. This value is independent from temperature, force and others. The values for the WDIs remain; they are precalibrated during manufacturing.

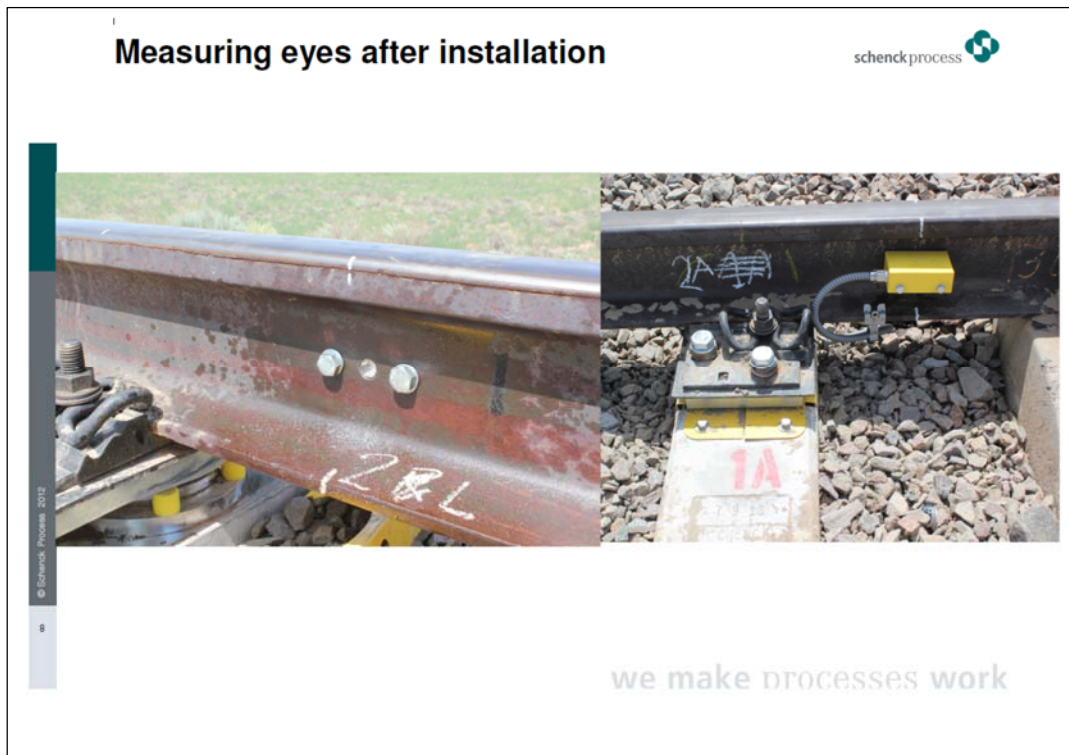
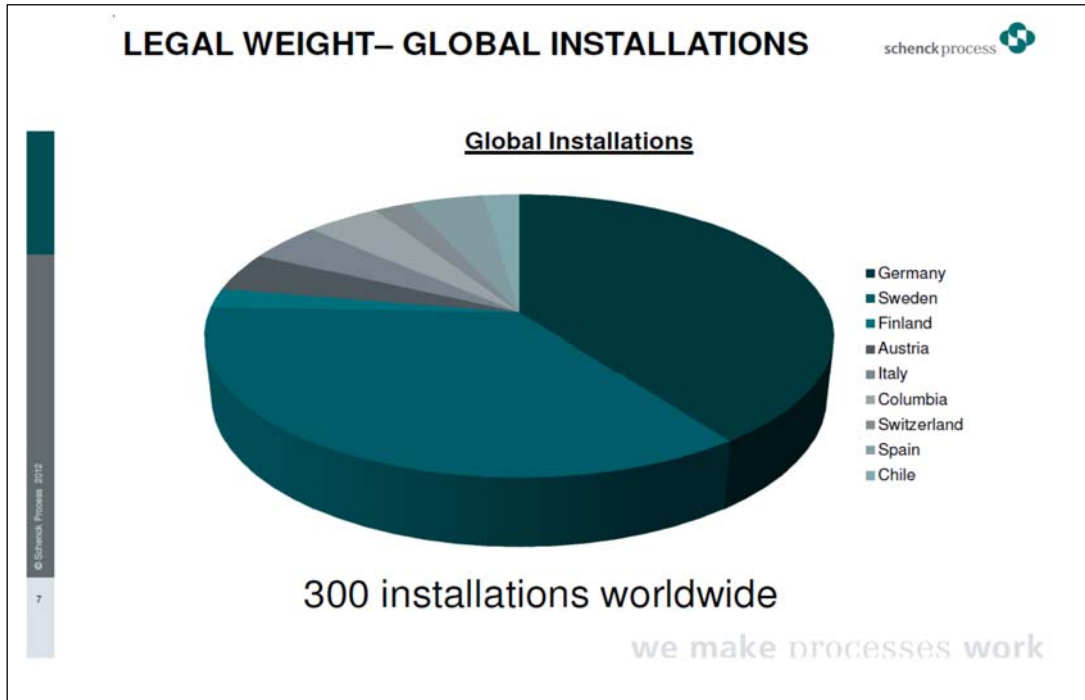

THE WEIGHING TIE

schenkprocess 

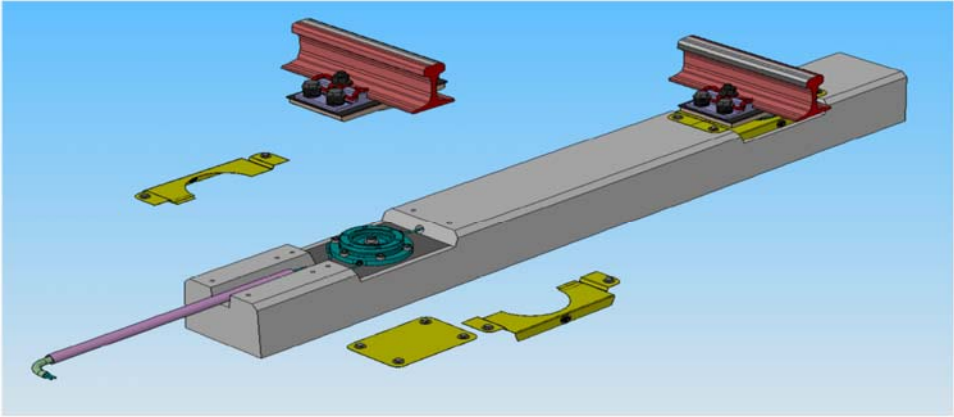

© Schenck Process 2012

we make processes work

schenkprocess 

2 Successful testing and changes needed to handbook



we make processes work

SUCCESSFUL TESTING



- In September 2013 we tested the system at the TTCI in Pueblo to NTEP HB44 guidelines
- We passed all testing both statically and dynamically
- Dynamic was tested to 14mph
- All testing was completed and witnessed by NTEP (Gipsa)
- System has now been tested to all existing HB 44 tolerances and specifications

© Schenck Process 2012

11

we make processes work

SUCCESSFUL US INSTALLATION



- A system was installed in December 2013 and commissioned in Jan 2014 in the USA.
- A very large system with 28 measuring ties (4x7 for liquid weighing)

Weights	Tonnage (t)
>9500 cars weighed	>1,000,000
Normal track switching	800,000
Accuracy	0.2%

© Schenck Process 2012

12

we make processes work

CURRENT RULE IN HANDBOOK



- Schenck Process has requested that a modification be made to section UR 2.4 which refers to scales have a cut in the rail and states “clearance shall be provided around all live parts to the extent that no contacts may result when the load-receiving element is empty, nor throughout the weighing range of the scale”.

we make processes work

SUGGESTED CHANGES



- Our suggestion Add a footnote after the word “scale” at the end of the first sentence that would read, “An in-motion railway track scale is not required to provide clearance using rail gaps to separate the live rail portion of the weighing/load-receiving element from that which is not live if the scale is designed to be installed and operated using continuous rail.”
- While leaving the original rule in place the handbook now reflects our proven design and technology

we make processes work

VOTING PASSED





- Change passed as a voting item through to the interim meeting by NEWMA and SWMA
- At the interim meeting the S&T committee decided to pass the item through as a voting item at the July meeting in Detroit
- Changes approved as a voting item by the CWMA
- Passed through as a voting item at the interim meeting at the start of 2014

we make processes work

MULTIRAIL® LegalWeight, LiquidWeight



we make processes work



Thankyou

we make processes work

© Schenck Process 2012
17

THIS PAGE INTENTIONALLY LEFT BLANK

Appendix B

NIST Handbook 44 – Scales

Item 320-3:

Revision 2 Draft Tentative Code Applicable to Weigh-In-Motion Systems Used for
Vehicle Enforcement Screening

Weigh-In-Motion Systems used for Vehicle Enforcement Screening – Draft Code

A. Application

- A.1. General.** – This code applies to systems used to weigh vehicles, while in motion, for the purpose of screening and sorting the vehicles based on the vehicle weight to determine if a static weighment is necessary.
- A.2.** The code does not apply to weighing systems intended for the collection of statistical traffic data.
- A.3.** The code is intended for field enforcement use only.
- A.4. Additional Code Requirements.** – In addition to the requirements of this code, Weigh-In-Motion Screening Systems shall meet the requirements of Section 1.10. General Code.

S. Specifications

S.1. Design of Indicating and Recording Elements and of Recorded Representations.

S.1.1. Ready Indication. – The system shall provide a means of verifying that the system is operational and ready for use.

S.1.2. Value of System Division Units. – The value of a system division “d” expressed in a unit of weight shall be equal to:

- (a) 1, 2, or 5; or
- (b) a decimal multiple or submultiple of 1, 2, or 5.

Examples: divisions may be 10, 20, 50, 100; or 0.01, 0.02, 0.05; or 0.1, 0.2, 0.5, etc.

S.1.2.1. Units of Measure. – The system shall indicate weight values using only a single unit of measure.

S.1.3. Value of Other Units of Measure.

S.1.3.1. Speed. – Vehicle speeds shall be measured in miles per hour or kilometers per hour.

S.1.3.2. Axle-Spacing (Length). – The center-to-center distance between any two successive axles shall be measured in feet and/or inches, or meters.

S.1.3.3. Vehicle Length. – If the system is capable of measuring the overall length of the vehicle, the length of the vehicle shall be measured in feet and/or inches, or meters.

S.1.4. Capacity Indication. – An indicating or recording element shall not display nor record any values greater than 105 % of the specified capacity of the load receiving element.

S.1.5. Identification of a Fault. – Fault conditions shall be presented to the operator in a clear and unambiguous means. The following fault conditions shall be identified:

- (a) Vehicle speed is below the minimum or above the maximum speed as specified.
- (b) The maximum number of vehicle axles as specified has been exceeded.
- (c) A change in vehicle speed greater than that specified has been detected.

S.1.6. Recorded Representations.

S.1.6.1. Values to be Recorded. – At a minimum, the following values shall be printed and/or stored electronically for each vehicle weighment:

- (a) transaction identification number;
- (b) lane identification (required if more than one lane at the site has the ability to weigh a vehicle in-motion);
- (c) vehicle speed;
- (d) number of axles;
- (e) weight of each axle;
- (f) identification and weight of axles groups;
- (g) axle spacing;
- (h) total vehicle weight;
- (i) all fault conditions that occurred during the weighing of the vehicle;
- (j) violations, as identified in paragraph S.2.1., that occurred during the weighing of the vehicle; and
- (k) time and date.

S.1.7. Value of the Indicated and Recorded System Division. – The value of the system's division size as recorded shall be the same as the division value indicated.

S.2. System Design Requirements.

S.2.1. Violation Parameters. – The instrument shall be capable of accepting user entered violation parameters for the following items:

- (a) single axle weight limit

- (b) axle group weight limit
- (c) gross vehicle weight
- (d) bridge formula load

The instrument shall display and or record violation conditions when these parameters have been exceeded.

S.3. Design of Weighing Elements.

S.3.1. Multiple Load-Receiving Elements. – An instrument with a single indicating or recording element, or a combination indicating-recording element, that is coupled to two or more load-receiving elements with independent weighing systems, shall be provided with means to prohibit the activation of any load-receiving element (or elements) not in use, and shall be provided with automatic means to indicate clearly and definitely which load-receiving element (or elements) is in use.

S.4. Design of Weighing Devices, Accuracy Class.

S.4.1. Designation of Accuracy. – WIM Systems meeting the requirements of this code shall be designated as accuracy Class A.

Note: This does not preclude higher accuracy classes from being proposed and added to this Code in the future when it can be demonstrated that WIM systems grouped within those accuracy classes can achieve the higher level of accuracy specified for those devices.

S.5. Marking Requirements. – In addition to the marking requirements in G-S.1. Identification (except G-S.1.(e)), G-S.4. Interchange or Reversal of Parts, G-S.6. Marking Operational Controls, Indications, and Features, G-S.7. Lettering, and G-UR.2.1.1. Visibility of Identification. The system shall be marked with the following information:

- (a) Accuracy Class;
- (b) Value of the System Division “d;”
- (c) Operational Temperature Limits;
- (d) Number of Lanes;
- (e) Minimum and Maximum Vehicle Speed;
- (f) Maximum Number of Axles per Vehicle;
- (g) Maximum Change in Vehicle Speed during Weighment; and
- (h) Minimum and Maximum Load.

S.5.1. Location of Marking Information. – The marking information required in G-S.1. Identification of the General Code and S.5. Marking Requirements shall be visible after installation. The information shall be marked on the system or recalled from an information screen.

N. Notes

N.1. Test Procedures.

N.1.1. Selection of Test Vehicles. – All dynamic testing associated with the procedures described in each of the subparagraphs of N.1.5. Test Procedures shall be performed with a minimum of two test vehicles.

- (a) The first test vehicle may be a two axle, six tire, single unit truck; a vehicle with two axles with the rear axle having dual wheels. The vehicle shall have a maximum Gross Vehicle Weight of 10 000 lb.
- (b) The second test vehicle shall be a five axle, single trailer truck with a maximum Gross Vehicle Weight of 80 000 lb.

Note: Consideration should be made for testing the systems using vehicles which are typical to the systems daily operation.

N.1.1.1. Weighing of Test Vehicles. – All test vehicles shall be weighed on a reference scale before being used to conduct the dynamic tests.

N.1.1.2. Determining Reference Weights for Axle, Axle Groups and Gross Vehicle Weight – The reference weights shall be the average weight value of a minimum of three static weighments of all single axle, axle groups and gross vehicle weight.

Note: The weight of individual axles within an axle group is not considered as a single axle. Only the weight of the axle group is used when conducting the test described in N.1.5. Test Procedures.

N.1.2. Test Loads.

N.1.2.1. Static Test Loads. – All static test loads shall use certified test weights.

N.1.2.2. Dynamic Test Loads. – Test vehicles used for dynamic testing shall be loaded to 85 % to 95 % of their maximum Gross Vehicle Weight. The “load” shall be non-shifting and shall be positioned to present as close as possible, an equal side-to-side load.

N.1.3. Reference Scale. – Each reference vehicle shall be weighed statically on a three platform vehicle. The scale shall have been certified to NIST Handbook 44, Class III L maintenance tolerances within the last 30 days.

N.1.3.1. Location of a Reference Scale. – The location of the Reference Scale must be considered as vehicle weights will change due to fuel consumption.

N.1.4. Test Speeds. – All dynamic tests shall be conducted within 20 % below or at the posted speed limit.

N.1.5. Test Procedures.

N.1.5.1. Dynamic Load Test. – The dynamic test shall be conducted using the test vehicles defined in N.1.1. The test shall consist of a minimum of 20 runs for each test vehicle at the speed as stated in N.1.4. Test Speeds.

At the conclusion of the dynamic test, there will be a minimum of 20 weight readings for each single axle, axle group, and gross vehicle weight. The tolerance for each weight reading shall be based on the percentage values specified in Table T.3.1. Tolerances as a Percentage of Applied Test Load.

N.1.5.2. Axle Spacing Test. – The axle spacing test is a review of the displayed and/or recorded axle spacing distance of the test vehicles. The tolerance value for each distance shall be based on the tolerance value specified in T.3.2.

N.1.5.3. Vehicle Position Test. – During the conduct of the dynamic testing the vehicle shall adjust its position along the width of the sensor from one run to the next but ensuring that the vehicle stays within the defined roadway. The test shall be conducted with 10 runs in the center, five runs on the right side, and five runs on the left side. All weighments shall be within tolerance.

T. Tolerances

T.1. Principles.

T.1.1. Design. – The tolerance for a weigh-in-motion system is a performance requirement independent of the design principle used.

T.2. Tolerance Application.

T.2.1. General. – The tolerance values are positive (+) and negative (–). No more than 5 % of each single axle, axle group or gross vehicle weight reading shall be outside the applicable tolerances.

T.3. Tolerance Values for Accuracy Class A.

T.3.1. Tolerance Values for Dynamic Testing. – The tolerance values applicable during dynamic load testing are as specified in Table T.3.1. Tolerances as a Percentage of Applied Test Load.

Table T.3.1. Tolerances for Accuracy Class A	
Load Description	Tolerance as a Percentage of Applied Test Load
Axle Load	20 %
Axle Group Load	15 %
Gross Vehicle Weight	10 %

T.3.2. Axle Spacing Tolerance. – The tolerance value applied to the axle spacing measurement shall be ± 0.5 ft (0.15 m).

T.4. Influence Factors. – The following factor are applicable to tests conducted under controlled conditions only.

T.4.1. Temperature. – Systems shall satisfy the tolerance requirements under all operating temperature unless a limited operating temperature range is specified by the manufacturer.

T.5. Radio Frequency Interference (RFI) and Other Electromagnetic Interference Susceptibility. – The difference between the weight indication due to the disturbance and the weight indication without the disturbance shall not exceed the tolerance value as stated in Table T.3.1. Tolerances for Accuracy Class A.

UR. User Requirements

UR.1. Selection Requirements. – Equipment shall be suitable for the service in which it is used with respect to elements of its design, including but not limited to, its capacity, number of scale divisions, value of the scale division, or verification scale division and minimum capacity.

UR.1.1. General.

The typical class or type of device for particular weighing applications is shown in Table 1. Typical Class or Type of Device for Weighing Applications.

Table 1. Typical Class or Type of Device for Weighing Applications	
Class	Weighing Application
A	Screening and sorting of vehicles based on axle, axle group and gross vehicle weight.
Note: A WIM system with a higher accuracy class than that specified as “typical” may be used.	

UR.2. User Location Conditions and Maintenance. – The system shall be installed and maintained as defined in the manufacturer’s recommendation.

UR.2.1. System Modification. – The dimensions (e.g., length, width, thickness, etc.) of the load receiving element of a system shall not be changed beyond the manufacturer’s specifications, nor shall the capacity of a scale be increased beyond its design capacity by replacing or modifying the original primary indicating or recording element with one of a higher capacity, except when the modification has been approved by a competent engineering authority, preferably that of the engineering department of the manufacturer of the system, and by the weights and measures authority having jurisdiction over the system.

UR.2.2. Foundation, Supports, and Clearance. – The foundation and supports shall be such as to provide strength, rigidity, and permanence of all components.

On load-receiving elements which use moving parts for determining the load value, clearance shall be provided around all live parts to the extent that no contacts may result when the load-receiving element is empty, nor throughout the weighing range of the system.

UR.2.3. Access to Weighing Elements. – If necessary, adequate provision shall be made for inspection and maintenance of the weighing elements.

UR.3. Maximum Load. – A system shall not be used to weigh a load of more than the marked maximum load of the system.

The following are proposed definitions to be added to NIST Handbook 44, Appendix D to support the Weigh-In-Motion Systems used for Vehicle Enforcement Screening – Draft Code.

weigh-in-motion (WIM). – A process of estimating a moving vehicle’s gross weight and the portion of that weight that is carried by each wheel, axle, or axle group, or combination thereof, by measurement and analysis of dynamic vehicle tire forces.

axle. – The axis oriented transversely to the nominal direction of vehicle motion, and extending the full width of the vehicle, about which the wheel(s) at both ends rotate.

axle-group load. – The sum of all tire loads of the wheels on a group of adjacent axles; a portion of the gross-vehicle weight.

axle load. – The sum of all tire loads of the wheels on an axle; a portion of the gross-vehicle weight.

axle spacing. – The distance between the centers of any two axles. When specifying axle spacing, you also need to identify the axles used.

single-axle load. – The load transmitted to the road surface by the tires lying on the same longitudinal axis (that axis transverse to the movement of the vehicle and about which the wheels rotate).

tandem-axle load. – The load transmitted to the road surface by the tires of two single-axles lying on the same longitudinal axis (that axis transverse to the movement of the vehicle and about which the wheels rotate).

triple-axle load. – The load transmitted to the road surface by the tires of three single-axles lying on the same longitudinal axis (that axis transverse to the movement of the vehicle and about which the wheels rotate).

Weigh-in-Motion Screening Scale. – A WIM system used to identify potentially overweight vehicles.

Wheel weight. – The weight value of any single or set of wheels on one side of a vehicle on a single axle.

WIM System. – A set of sensors and supporting instruments that measure the presence of a moving vehicle and the related dynamic tire forces at specified locations with respect to time; estimate tire loads; calculate speed, axle spacing, vehicle class according to axle arrangement, and other parameters concerning the vehicle; and process, display, store, and transmit this information. This standard applies only to highway vehicles.

THIS PAGE LEFT INTENTIONALLY BLANK

Appendix C

NIST Handbook 44 – Liquid-Measuring Devices

Item 330-4:

N.4.2.5. Determination of Error on Wholesale Devices with Multiple Flow Rates and Calibration Factors

How Slow Flow Accuracy Affects LMD's

Because the legal tolerance on slow flow tests is so great (+/-0.5%) compared to industry standards (typically +/- 0.05%), and because slow flow tests themselves are so time consuming, registered service agents may be tempted to skip slow flow tests entirely during seasonal re-calibrations. Even if one ignores the fact that the Liquid Measuring Device Code in NIST Handbook 44 requires that a special test be done at the slow flow rate, there remains a very good reason that slow flow rates should always be tested. If the error at the slow flow rate is unknown, then it is impossible to calibrate the high flow rates to deliver with the extreme accuracy sought by industry on quantities which are greater or less than the test prover used at the time of calibration.

Imagine a typical whole sale meter which is calibrated using a 1,000 gallon prover at a terminal where the customers' trucks have pocket sizes between 1,000 and 4,000 gallons. The meter has an electronic register programmed with a slow flow rate for start-up and shut-down, a high-flow rate for typical deliveries, and a mid-speed fallback rate for when the pumps can't keep up with demand. Startup and shutdown deliveries are 100 gallons each regardless of total quantity delivered.

Now imagine that the service agent calibrating the meter didn't check the slow flow rate and didn't know that the meter was short five gallons on a one thousand gallon test. Instead, he calibrated the fallback and normal flow rates without testing the slow flow and introduced a linear error which increases the farther the transaction quantity deviates from the prover size. On a 1,000 gallon delivery the meter would appear to be accurate, but on a 3,400 gallon delivery a three gallon error has been introduced. That is a 0.09% error which is almost twice the typical industry goal.

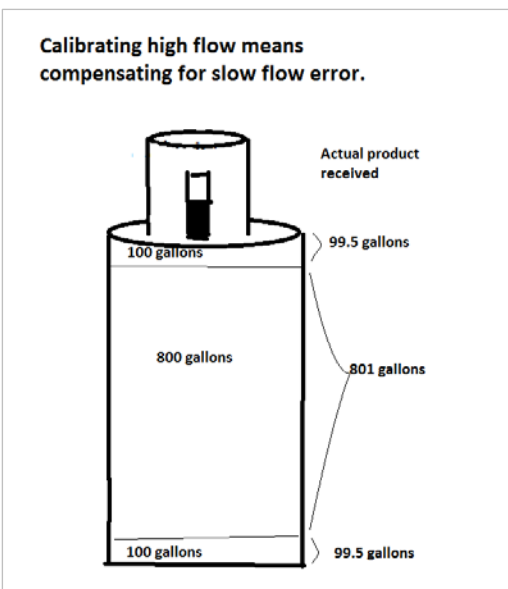

When calibrating at the normal and fallback speeds, the meter registers 200 gallons of product for the startup and shutdown, but actually delivers only 199 gallons. (99.5 gallons delivered for every 100 gallons registered at slow speed.) If the service technician calibrates the meter to zero at normal and fallback rates, the meter will actually deliver 801 gallons for every 800 gallons it registers at those rates.

Every subsequent delivery of 1000 gallons should receive exactly the right amount. Every delivery exceeding 1000 gallons will be 'long' and every delivery less than 1000 gallons will be short.

To determine the error on a typical delivery, the service agent needs to calculate the error introduced by the startup and shutdown gallons, and then the error introduced at the higher flow rates.

For a 3,400 gallon delivery in this example, the meter would register 100 gallons on startup but only deliver 99.5 gallons. It would then jump to normal rate and deliver 801 gallons for every 800 gallons it registers until it goes into shutdown mode when it slows down and again delivers only 99.5 gallons of the 100 gallons it registers. Delivery error is +3 gallons (0.09%).

EXAMPLE SLOW FLOW IS 5G/1000G SHORT AND HIGH FLOW WAS ADJUSTED AS A RESULT.

Driver ordered 3400 gallons for pocket 2.

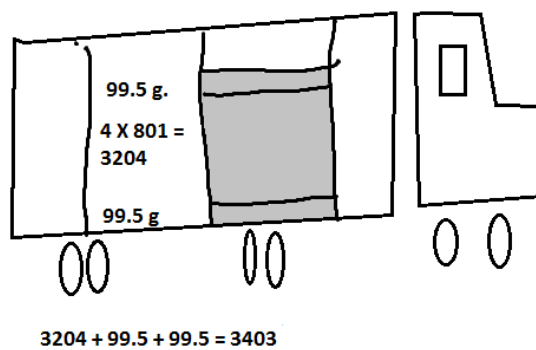

EXAMPLE WHEN SLOW FLOW RATE IS 5G/1000G LONG AND HIGH FLOW WAS ADJUSTED AS A RESULT.

Driver ordered 3400 gallons for pocket 2.

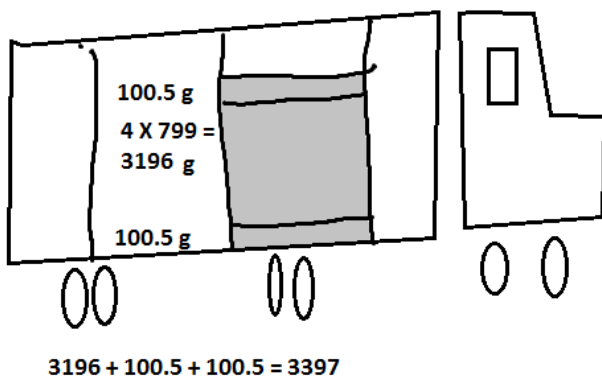

The math would be reversed if the meter had been five gallons long on a 1,000 gallon slow flow test at the startup and shutdown speed. The meter would deliver 100.5 gallons for every 100 gallons it registered at startup and shutdown, but only 799 gallons for every 800 gallons registered at the normal delivery rate. The total delivery is 3 gallons (0.09%) short. Under-registration, which is favorable to consumers in most situations, can be detrimental to them when it occurs at the slow flow speed.

Does it matter considering that the error introduced is so much smaller than the tolerance allowed in the liquid measuring code? It does to industry, or they wouldn't set such tight accuracy standards for themselves. And it does to Weights & Measures officials who must consider the predominant direction of error in addition to tolerance. Everyone's time is wasted chasing extreme accuracy at the normal delivery rate if the accuracy of the startup and shutdown rate has been ignored.

Appendix D

NIST Handbook 44 – Vehicle-Tank Meters

Item 331-1:

N.4.2.1. Determination of Error on Vehicle-Tank Meters with Multiple Flow Rates and Calibration Factors

How Slow Flow Errors Affect VTM's

Imagine a typical VTM which is calibrated using a 100 gallon prover for a bulk delivery company whose customers' tanks are typically between 100 and 1,000 gallons. The meter has an electronic register programmed with a slow flow rate for start-up and shut-down, and a high-flow rate for typical deliveries. Startup and shutdown deliveries are 10 gallons each regardless of total quantity delivered.

Now imagine that the service agent calibrating the meter didn't check the slow flow rate and didn't know that the meter was long 0.4 gallons on a 100 gallon test. Instead, he calibrated the normal flow rate without testing the slow flow and introduced a linear error which increases the farther the transaction quantity deviates from the prover size. On a 100 gallon delivery the meter would appear to be accurate, but on a 500 gallon delivery a -0.4 gallon error has been introduced. That is within tolerance, but if all of his meters have similar errors in the same direction, typical deliveries will be in the operator's favor at the expense of his customers.

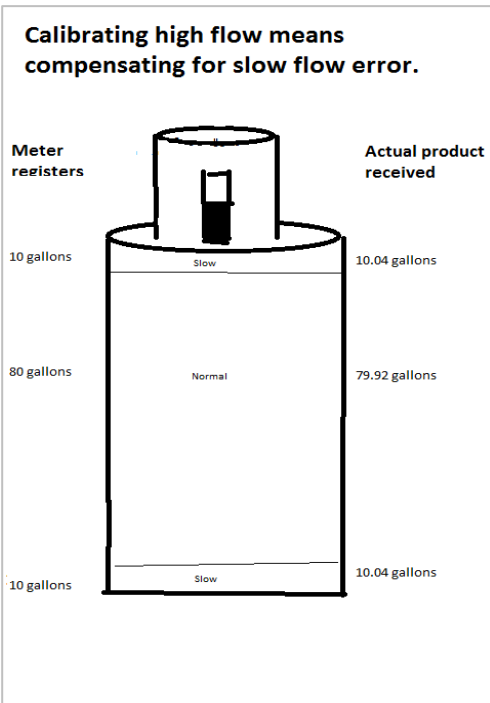

When calibrating at the normal speed, the meter registers 20 gallons of product for the startup and shutdown, but actually delivers 20.08 gallons. (10.04 gallons delivered for every 10.00 gallons registered at slow speed.) If the service technician calibrates the meter to zero at normal speed, the meter will actually deliver 79.92 gallons for every 80.00 gallons it registers at that flow rate.

Every subsequent delivery of 100 gallons should receive exactly the right amount. Every delivery exceeding 100 gallons will be 'short' and every delivery less than 100 gallons will be 'long.'

To determine the error on a typical delivery, the service agent needs to calculate the error introduced by the startup and shutdown gallons, and then the error introduced at the higher flow rates.

For a 500 gallon delivery in this example, the meter would register 10 gallons on startup but actually deliver 10.04 gallons. It would then jump to normal rate and deliver 79.92 gallons for every 80 gallons it registers until it goes into shutdown mode when it slows down and again delivers 10.04 gallons as it registers only an additional 10 gallons.

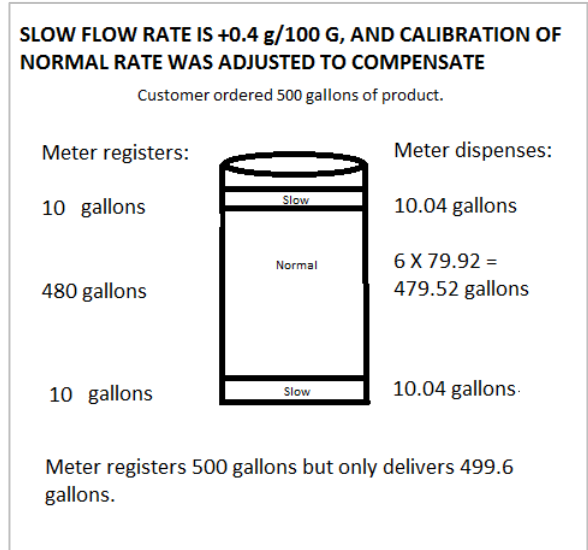

The error would be well within maintenance tolerance so the Weights and Measures official need only be concerned if the slow flow errors on all the meters for a particular product are in the same direction. At that point, the official should determine the direction of the error on a typical deliver to determine if the equipment is being properly maintained. Device users can ensure they have no problems with this requirement by making sure that slow flow errors are not predominantly in one direction.

Appendix E

NIST Handbook 44 – Mass Flow Meters

Item 337-2:

Submitters Background and Justification for NIST Handbook 44 Definition of “Diesel Gallon Equivalent (DGE)” of Compressed Natural Gas (CNG) and Liquefied Natural Gas (LNG) as a Vehicular Fuel Clean Vehicle Education Foundation

Development of the “Gasoline Gallon Equivalent” by NCWM*

In 1993, under the auspices of the National Conference on Weights and Measures (NCWM), a Compressed Natural Gas (CNG) Working Group came together to determine the way in which CNG would be sold to the public at retail as a motor fuel.

The working group focused on three issues:

1. How to provide the Natural Gas Vehicle (NGV) industry a method of sale that would be familiar and acceptable to consumers
2. How to provide weights and measures officials a verifiable and quantifiable means to determine the accuracy of natural gas dispensers; and
3. How to meet these requirements with a uniform, national standard.

NCWM considered three proposals for the method of sale of CNG:

1. Joules, the unit of energy measurement in SI units
2. Mass
3. The Gasoline Gallon Equivalent (GGE)

The Natural Gas Vehicle Coalition (now NGVAmerica) recommended that the Gasoline Gallon Equivalent be adopted as the method of sale for CNG, and that it be based on the energy equivalent of a gallon of gasoline. The use of the GGE was recommended primarily for the convenience of the retail customer comparing the cost and fuel economy of a natural gas vehicle to a comparable gasoline vehicle. During the discussion, a proposal was made to eliminate the reference to energy content of CNG and replace it with a fixed conversion factor based on mass, with the fixed mass of CNG being equal to a gallon of gasoline. Measurement of mass in the retail dispenser and verification by WEIGHTS AND MEASURES officials is easier and less costly than measurement of energy content.

Since the energy content of a unit measure of CNG (standard cubic foot - scf) and gasoline (gallon) vary widely depending on the sample of fuel measured, the reference gallon of gasoline was determined to be Indolene, the gasoline used by EPA to certify emissions and fuel economy, with an energy content (lower heating value) of 114,118 BTU/gal. Work conducted by the Institute of Gas Technology and the Gas Research Institute (now combined into the Gas Technology Institute) surveyed 6811 samples of natural gas nationwide and concluded that the “average” natural gas in the US had an

* *Report of the 78th National Conference on Weights and Measures, 1993*, NIST Special Publication 854, pp 322-326.

Report of the 79th National Conference on Weights and Measures, 1994, NIST Special Publication 870, pp 213-217.

Program and Committee Reports for the National Conference on Weights and Measures, 79th Annual Meeting, July 17-21, 1994, NCWM Publication 16, pp 89-92.

energy content (lower heating value) of 923.7 BTU/scf, and a density of 0.0458172 lbs/cubic foot. This translates 20,160.551 BTU/lb. Dividing gasoline's 114.118 BTU/gal by natural gas's 20,160.551 BTU/lb gives 5.660 lbs of natural gas = 1 GGE. Similar calculations determined that a gasoline liter equivalent of natural gas equals 0.678 kg of natural gas.

At its 79th Annual Meeting in July of 1994, NCWM adopted resolutions that:

“All natural gas kept, offered or exposed for sale or sold at retail as a vehicle fuel shall be in terms of the gasoline liter equivalent (GLE) or gasoline gallon equivalent (GGE), and

All retail natural gas dispensers shall be labeled with the conversion factor in terms of kilograms or pounds. The label shall be permanently and conspicuously displayed on the face of the dispenser and shall have either the statement “1 Gasoline Liter Equivalent (GLE) is equal to 0.678 kg of Natural Gas” or “1 Gasoline Gallon Equivalent (GGE) is equal to 5.660 lbs of Natural Gas” according to the method of sale used.”

These statements can be found in NIST Handbook 130^{*}, along with the definition of “natural gas” which seems to apply only to Compressed Natural Gas, not to Liquefied Natural Gas. Handbook 130, §§3.11 and 3.12. (Engine Fuels, Petroleum Products, and Automotive Lubricants Regulations) confirm that these requirements are for CNG, rather than LNG. Similar requirements and definitions are found in NIST Handbook 44.

During the discussions it was recognized that, although diesel and gasoline are both sold in gallon units, a gallon of diesel fuel has substantially more energy content than a gallon of gasoline. While it is convenient to use the Gasoline Gallon Equivalent unit when comparing the cost and fuel economy of gasoline-powered light-duty vehicles to equivalent natural gas vehicles, a Diesel Gallon Equivalent unit would be more useful for operators of medium and heavy-duty (usually diesel powered) vehicles. However, in 1994, the NCWM working group “agreed to defer development of a “Diesel Gallon Equivalent” until the issues related to the ‘Gasoline Gallon Equivalent’ were decided by the NCWM and agreed to meet again if additional work is necessary.”** The issue of the formal definition a Diesel Gallon Equivalent (DGE) unit has not come before NCWM from that time until today, although the DGE is often used in the industry, defined as 6.31 lbs of compressed natural gas.

Need for a Definition of a “Diesel Gallon Equivalent” Unit

Today there are an increasing number of commercial vehicles using natural gas as a fuel, to lower emissions and Greenhouse Gases, decrease America's use of petroleum, and lower fuel costs (U.S. DOE Clean Cities Alternative Fuel Price Report for April 2012

* “Method of Sale Regulation,” §2.27

** *Report of the 79th National Conference on Weights and Measures, 1994*, NIST Special Publication 870, p 214

shows in Table 2 ‘Overall Average Fuel Price on Energy-Equivalent Basis’ that diesel is priced at \$4.12/gal and CNG at \$2.32/gal

http://www.afdc.energy.gov/afdc/pdfs/afpr_apr_12.pdf).

Since the NCWM’s working group deferred development of a DGE unit in 1994, there has been little call by the natural gas vehicle industry for the formalization of that unit in the sale of Compressed Natural Gas. However the use of **Liquefied** Natural Gas (LNG) as a motor fuel has been growing (more than 350 LNG stations are being built on the nations interstate Highways) and there is significant interest in using the DGE as a unit for the sale of that fuel.

LNG as a motor fuel is used almost exclusively by commercial vehicles, most of which view diesel as the conventional alternative. Using the same logic as was used for the development of the GGE unit, the convenience of the retail customer comparing the cost and fuel economy of a natural gas vehicle to a comparable conventional vehicle, it makes sense for NCWM to now “officially” define the DGE.

Other than §3.12. Liquefied Natural Gas, in the Engine Fuels and Automotive Lubricants

Regulation section of Handbook 130, we find no specific provisions in either Handbook

44 or Handbook 130 for the retail sale of LNG as a motor fuel. However LNG is sold in

California and other states on a mass basis (by the pound), which allows for easy confirmation by weights and measures authorities. An “official” definition of the DGE as a specific mass of LNG and CNG would allow states to easily move from retail sale by pound to retail sale by DGE, simplifying the sale process for the retail customer used to dealing with “gallons of diesel” as a fuel measure.

Therefore, at this time we are asking for a definition of the Diesel Gallon Equivalent (and Diesel Liter Equivalent) units by NCWM.

Justification of the Definition of a DGE as 6.38 Pounds of Compressed Natural Gas Handbook 130

contains the following definitions of natural Gas as a vehicle fuel* : **Gasoline liter equivalent**

(GLE). – Gasoline liter equivalent (GLE) means
0.678 kg of natural gas.

Gasoline gallon equivalent (GGE). – Gasoline gallon equivalent (GGE) means
2.567 kg (5.660 lb) of natural gas.

As the NCWM working group recognized during its deliberations in 1993 on the Gasoline Gallon Equivalent unit, both gasoline and natural gas can vary in their BTU content from sample to sample. The working group determined the gasoline gallon (energy) equivalent based on a gallon of Indolene (114,118 BTU/gal – lower heating value) and a survey of 6811 natural gas samples nationwide with an average of 923.7 BTU/scf (lower heating value) and a density of 0.0458172 lbs/cubic foot. This equates

* NIST handbook 130, 2006, Method of State Regulation, §§2.27.1.2 and 2.227.1.3; also Engine Fuels, Petroleum Products, and Automotive Lubricants Regulation, §§1.25 and 1.26.

to 20,160.551 BTU/lb. Dividing gasoline's 114.118 BTU/gal by natural gas's 20,160.551 BTU/lb gives 5.660 lbs of natural gas = 1 GGE. Similar calculations determined that a gasoline liter equivalent of natural gas equals 0.678 kg of natural gas.

Starting with 5.660 lbs of natural gas = 1 GGE and 0.678 kg of natural gas = 1 GLE, we can calculate the mass of natural gas necessary to make a DGE and a DLE by comparing the amount of energy in a gallon of diesel fuel to the amount of energy in a gallon of gasoline fuel and apply that ratio to scale up the masses of natural gas calculated for the GGE and GLE units.

Unfortunately it is no easier today than it was in 1993 to set one energy value as representative of a unit for all gasoline, (or diesel) fuel. EPA's certification fuel has likely changed in energy content since 1993, as both gasoline and diesel fuels have been modified for improved emissions.

We recommend using the most recent Department of Energy *Transportation Energy Data Book*^{*}, as an authoritative reference for both gasoline and diesel fuel energy values. Taking further surveys or basing our calculations on today's EPA certification fuel only delays our action, substantially increases costs, and, in the end, provides a limited potential increase in accuracy based on one point in time. Table B.4 of the *Transportation Energy Data Book*, on the heat content of fuels lists the net energy of diesel as 128,700 BTU/Gal. The 31st Edition may be downloaded at the following site.

<http://cta.ornl.gov/data/download31.shtml>

Therefore a Diesel Gallon Equivalent of compressed natural gas is: $(128,700 \text{ BTU/Gal} / 20,160.551 \text{ BTU/lb}) = 6.38 \text{ lb/DGE}$ (2.894 kg/DGE) and a Diesel Liter Equivalent of compressed natural gas is:
 $2.894 \text{ kg/DGE} \times 0.2642 \text{ Gal/Liter} = 0.765 \text{ kg/DLE}$

Justification of the Definition of a DGE as 6.06 Pounds of Liquefied Natural Gas

Cooling pipeline natural gas to -259°F makes liquefied Natural Gas (LNG). The pipeline natural gas has the same national average composition as was determined for CNG

with a LHV of 20,160.551 BTU/lb. In order to reduce the natural gas temperature for liquefaction carbon dioxide must be removed since it would solidify in the system and

nitrogen, which remains a gas at LNG temperatures, is reduced to less than 0.5% by volume in the final product. These changes to the composition of the pipeline gas increase the LHV of LNG to 21,240 BTU/lb.

* Stacy C. Davis and Susan W. Diegel, Oak Ridge National Laboratory, *Transportation Energy Data Book*, Edition 31, 2012, ORNL-6987, or <http://cta.ornl.gov/data/index.shtml>

National Average Natural Gas Composition Used for GGE Standard - Applied to LNG DGE - GGE Calculation								
CNG				LNG				
Components	LHV - BTU/LB	LBS/CF	%V ¹	%V ²	LBS/CF	%MASS	LHV	
C1	21537	0.0425	92.87	95.12	0.040425567	90.29305699	19446.41568	
C2	20394	0.0803	3.34	3.42	0.002746969	6.13552872	1251.279727	
C3	19807	0.1196	0.63	0.65	0.000771727	1.723700114	341.4132816	
i-C4	19529	0.1582	0.07	0.07	0.000113422	0.253334595	49.47371306	
n-C4	19815	0.1582	0.12	0.12	0.000194437	0.434287877	86.05414286	
i-C5	19478	0.1907	0.04	0.04	7.81272E-05	0.174502103	33.98951966	
n-C5	20485	0.1907	0.03	0.03	5.85954E-05	0.130876577	26.81006688	
C6	19403	0.0228	0.05	0.05	1.16761E-05	0.026079234	5.06015379	
N2	0	0.0744	2.07	0.50	0.000370992	0.828633789	0	
CO2	0	0.117	0.78	0.00	0	0	0	
			100.00	100.00	0.044771512	100	21240	
							Diesel ³ LHV=	128,700
							LNG - DGE=	6.06

¹ CNG national average composition of natural gas from the NCWM Laws and Regulations - CNG Working Group letter 10/18/1993 Appendix A. Conversion Factor Background

² LNG composition based on CNG composition with CO2 removed and nitrogen reduced to 0.5%

³ DOE Transportation Energy Data Book Table B.4

Note: each 0.1% reduction/addition of nitrogen in LNG lowers/raises DGE by 0.01 lb

Therefore a Diesel Gallon Equivalent of LNG is:

$$128,700 \text{ BTU/lb} / 21,240 \text{ BTU/lb} = 6.06 \text{ lb/DGE} (2.749 \text{ kg/DGE})$$

and a Diesel Liter Equivalent of LNG is:

$$2.749 \text{ kg/DGE} \times 0.2642 \text{ Gal/Liter} = 0.7263 \text{ kg/DLE}$$

The attached presentation file provides an overview of the CNG and LNG processes from pipeline to dispensing along with the calculation of the LNG LHV based on the change in LNG chemical composition through the liquefaction process.

Prepared by:

Clean Vehicle Education Foundation

<http://www.cleanvehicle.org>

Clean Vehicle Education Foundation

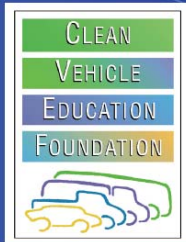

Proposal for CNG & LNG – DGE
NCWM
March 20, 2013

Douglas Horne – President

12/10/13

www.cleanvehicle.org

1

Why DGE is Now Needed by the NGV Market

- In the 1994 NCWM set GGE at 5.66 lbs but deferred the development of DGE because:

The consumer market was LD gasoline conversions



and diesel class NGVs were fleets such as transit that use private stations.



In the last twenty years the market growth has been in HD vehicles and now a national network of of public CNG and LNG - LCNG fueling is emerging

CNG Class 8



LNG Class 8



CNG HD



12/10/13

www.cleanvehicle.org

2



CNG DGE

Based on 1994 NCWM GGE Standard

- The 1994 acceptance NCWM of Gasoline Gallon Equivalent (GGE) for natural gas to be equal to 5.660 lbs was based on a national weighted average composition of natural gas
 - density of 0.0458172 lbs/scf
 - LHV = 20,160.551 BTU/lb
- Using the the same natural gas composition and the LHV of diesel noted in Table B.4 of the DOE Transportation Energy Data Book
 - 128,700/20,160.551 gives the Diesel Gallon Equivalent (DGE) of 6.38 lbs
- For those NGVs that use CNG as a replacement for diesel, a DGE of CNG would be 6.38 lbs

12/10/13 www.cleanvehicle.org 4

DGE for Vehicle Using LNG and

- As shown in the LNG delivery system slide the national average pipeline gas has a LHV of 20,160 BTU/lb and during liquefaction the inert gas constituents are reduced thus increasing the LHV to 21,240 BTU/lb
 - For those NGVs that use LNG as a replacement for diesel, a DGE of LNG would be 128,700 LHV diesel divided by 21,240 LHV of LNG equaling 6.06 lbs

12/10/13

www.cleanvehicle.org

5

DGE & GGE Based on LNG Composition

National Average Natural Gas Composition Used for GGE Standard - Applied to LNG DGE - GGE Calculation								
CNG				LNG				
Components	LHV - BTU/LB	LBS/CF	%V ¹	%V ²	LBS/CF	%MASS	LHV	
C1	21537	0.0425	92.87	95.12	0.040425567	90.29305699	19446.41568	
C2	20394	0.0803	3.34	3.42	0.002746969	6.13552872	1251.279727	
C3	19807	0.1196	0.63	0.65	0.000771727	1.723700114	341.4132816	
i-C4	19529	0.1582	0.07	0.07	0.000113422	0.253334595	49.47371306	
n-C4	19815	0.1582	0.12	0.12	0.000194437	0.434287877	86.05414286	
i-C5	19478	0.1907	0.04	0.04	7.81272E-05	0.174502103	33.98951966	
n-C5	20485	0.1907	0.03	0.03	5.85954E-05	0.130876577	26.81006688	
C6	19403	0.0228	0.05	0.05	1.16761E-05	0.026079234	5.06015379	
N2	0	0.0744	2.07	0.50	0.000370992	0.828633789	0	
CO2	0	0.117	0.78	0.00	0	0	0	
			100.00	100.00	0.044771512	100	21240	
							Diesel ³ LHV=	128,700
							LNG - DGE=	6.06

¹CNG national average composition of natural gas from the NCWM Laws and Regulations - CNG Working Group letter 10/18/1993 Appendix A. Conversion Factor Background

²LNG composition based on CNG composition with CO2 removed and nitrogen reduced to 0.5%

³DOE Transportation Energy Data Book Table B.4

Note: each 0.1% reduction/addition of nitrogen in LNG lowers/raises DGE by 0.01 lb

12/10/13

www.cleanvehicle.org

6

Proposal

- CNG dispensers may dispense natural gas in two units:
GGE = 5.66 lbs
DGE = 6.38 lbs
- LNG dispensers will dispense LNG in one unit:
DGE = 6.06 lbs

12/10/13

www.cleanvehicle.org

7

CVEF Contact Information

- Douglas Horne – President
dbhorne@cleanvehicle.org
770-424-8575
- www.cleanvehicle.org

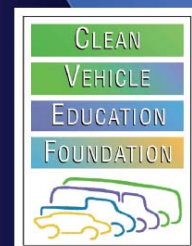

12/10/13

www.cleanvehicle.org

8

THIS PAGE INTENTIONALLY LEFT BLANK

Appendix F

NIST Handbook 44 – Multiple Dimension Measuring Devices

Item 358-1:

Measurement of Bulk Material in Open-Top Truck and Trailer Units

**Load Volume Scanner Metrology, Test methods & Suitability for Use
by Loadscan Ltd.**

THIS PAGE INTENTIONALLY LEFT BLANK



Load Volume Scanner (LVS) Metrology, Test Methods and Suitability for Use



CONFIDENTIAL - NOT INTENDED FOR PUBLIC DISTRIBUTION

This document is intended to provide explanatory notes and discussion points for trade measurement authorities only.

Copyright © 2013 LoadScan Ltd, New Zealand
Author: Adrian Ruthe, Technical Manager

Contents

<i>Introduction</i>	2
<i>Background</i>	2
<i>Principle of Operation</i>	3
<i>Metrological Characteristics</i>	5
<i>General Metrological Characteristics</i>	5
<i>Sources of Measurement Error</i>	8
<i>Accuracy Classification</i>	10
<i>Test Methods</i>	11
<i>Current Methods</i>	11
<i>Practical Constraints on Test Load Generation</i>	13
<i>Alternative Standardized Method</i>	14
<i>Suitability for Use</i>	15
<i>Primary Application Areas</i>	15
<i>Traditional Measurement Methods</i>	17
<i>Accuracy Limitations in Volumetric Load Determination</i>	18
<i>Key Advantages of the LVS</i>	19
<i>Limitations and Potential Objections</i>	19

Introduction

This document is intended to provide additional information about the LoadScan/TallyClerk Load Volume Scanner to assist trade measurement authorities in evaluating the instrument only. It is not intended as a general introduction to the product or its usage.

Background

The Load Volume Scanner (LVS) is a non-contact volumetric measurement instrument designed to measure loads of bulk loose solids in open-bin truck and trailer units. Typical applications are in civil construction, quarrying, mining, mulch manufacturing, debris cleanup, recycling and other industries where bulk materials are traded by the truck load and volume is the key quantity of interest or the most practical form of measure.

- The TallyClerk development project was initiated in 1998 to provide a solution to industry requirements for accurate tally of construction aggregate and spoil movements on, off and around civil construction sites.
- The LVS achieved type approval for trade use in New Zealand in 1999 and in Australia in 2010.
- TallyClerk has been re-branded to LoadScan and now has over 75 installations around the world, the majority in New Zealand.
- The LVS format includes fully mobile, portable and fixed-mount models.
- The LVS is now used to measure a wide range of bulk load materials in a full spectrum of truck designs across multiple industries.



Principle of Operation

Trucks are "scanned" by driving slowly below an elevated Scan Head. This is essentially a mounting platform for two scanning laser range-finders, which we will refer to as laser scanners. When a truck crosses the Scan Area below the Scan Head it falls within the field of view of these laser scanners which perform thousands of distance measurements per second.



The LVS processes the distance data measured by the laser scanners as a truck passes below and constructs a composite 3D model or 'surface profile' in software. A vehicle is initially scanned empty and recorded into the system database as an **empty vehicle profile** (zero reference). Load volume is computed on subsequent scans by comparing each new **loaded vehicle profile** against the recorded empty profile. This involves aligning the empty and loaded vehicle profiles spatially in software and computing a **load profile** from the difference between them.

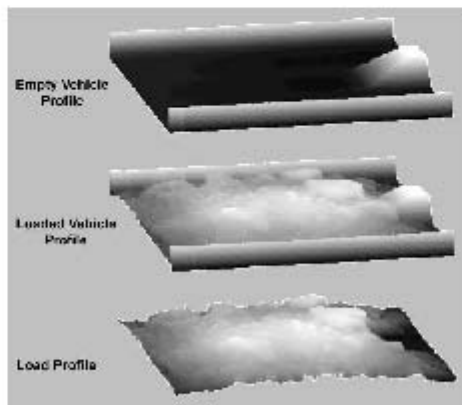

The LVS measures the load as it sits in the truck at the time of measurement. The measured volume is the "loose" volume generated by the surface contour and it makes no assumptions about product density or changes in volume over time.

The scanning process is fully automated and a touch-screen Operator Console provides for operator control and monitoring of the system. Trucks and trailers can be identified manually, or they can be fitted with RFID Tags that automatically identify the vehicle(s) when scanned. Measurement results are displayed on the Operator Console screen and loading tickets can be printed automatically with an optional Ticket Printer. Results are also displayed on a high visibility LED Message Board. Permanent records are saved to log files which can be transferred to other systems for analysis, invoice generation and reporting.

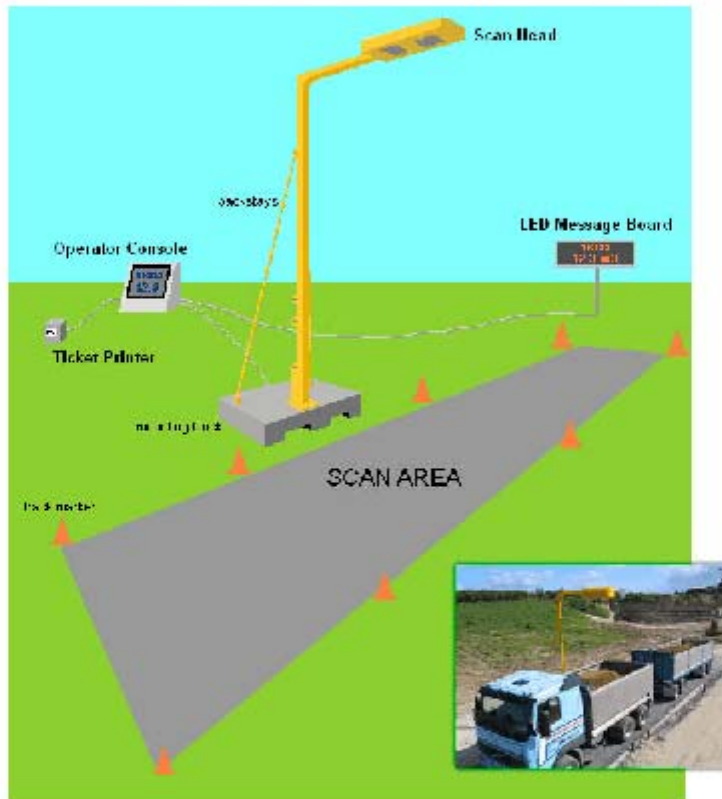

Metrological Characteristics

General Metrological Characteristics

Basic Specifications

Unit of Measure	Cubic metre (m ³) or cubic yard (yd ³) <i>according to regional requirements</i>
Measurement Range (per bin)	0 – 130 m ³ (0 – 170 yd ³) <i>or as set by regional trade measurement authorities</i>
Scale Interval (resolution)	0.1 m ³ / 0.1 yd ³ <i>or as set by regional trade measurement authorities</i>
Measurable Vehicle Types	Open bin road-legal truck, truck-trailer, semi-trailer and B-train combinations (including bottom-dump, side-tipper and belt unloaders); Road-trains with up to 4 bins; Rigid bodied and articulated off-highway dump trucks (mine, quarry, underground); solid sided rectangular tractor trailers. Maximum 3m (10') wide, 4.25m (14') high for standard fold-down LVS. Custom mounting may be required for larger trucks.
Measurable Bin Capacity (truck/trailer size)	1.5 – 130.0 m ³ (2.0 – 170 yd ³) <i>or as set by regional trade measurement authorities</i>
Measurable Load Types	<i>Except where limited by regional trade measurement authorities:</i> Flowable solids (bulk loose materials) including but not limited to: <ol style="list-style-type: none"> a) Earth, sand, gravel or other similar material b) Mulch, bark, compost or other similar landscaping products and raw constituent materials c) Woodchip or sawdust d) Unprocessed ore, coal or mining waste e) Bulk recycled materials in crushed, shredded or similar form f) Lumpy, irregular mixed materials where sold as waste or debris
Maximum Load Particle Diameter (average)	200 mm (7.8") <i>no limit for non-trade applications</i>
Typical Measurement Accuracy	Better than 1% to limit of resolution
Vehicle Speed (during scanning)	0.5 – 6.0 kmph (0.3 - 3.7 mph)
Power Requirements	24VDC, 13A max or 110 - 240 VAC, 50/60Hz, 4A max with AC power supply installed
Laser Protection Class	Class 1 (eye-safe)
Clearance (from Ground)	5.0 m (16.4') minimum (depends on mounting system and type of vehicles to be scanned)

Rated Operating Conditions

Operating Temperature	-30 – 50°C (-22 – 122 °F) Scan Head, LED Message Board 0 – 45°C (32 – 113 °F) Operator Console, Printer
Minimum Visibility	50 m (164') (dense fog)
Maximum Scan-Track Gradient	5 degrees (9%)
Maximum Scan-Track Camber	3 degrees (5%)

Type Classification

The LVS does not fit into any existing internationally recognized standard instrument classification defined for other types of measurement instruments and none exists specifically for the LVS. In New Zealand and Australia, where the LVS currently has type approvals, the trade measurement authorities have borrowed from and modified existing classifications to create type approval specifications for the LVS.

In terms of principle of operation and unit of measure, the LVS is best compared to **Multi-Dimensional Measuring Instruments**¹ used for determining the dimensions and/or volume of objects for the purpose of calculating freight, storage, or postal charges based on the dimensions and/or volume occupied by the object. The scanning laser rangefinder technology utilized by the LVS is essentially the same as used by the latest generation of these instruments. However, the instrument design, metrological characteristics and application is significantly different and the LVS does not fit well into this type classification. Some of the existing guidelines for Multi-Dimensional Measuring Instruments can be applied to the LVS.

In terms of application, the LVS is better compared to instruments for **Vehicle Weighing in Motion**² such as axle weighers and other in-motion weighbridges. However, the technology is very different and these instruments measure weight, not volume. Some elements of the existing guidelines for Vehicle Weighing in Motion can be applied to the LVS.

Brim Measures or Dry Measures³ including front-end loader buckets or other measures of fixed capacity for the measurement of solids are also comparable in terms of unit of measure and type of materials measured.

Scan Head Mounting

The scan head support structure may be varied to suit the installation or portability requirements. In all cases the mechanical support mechanism provides stable mounting for the scan head, in the required location relative to the scan area and does not alter the metrological characteristics of the instrument. Standard clearance from ground is approximately 5.2m but this may be increased for scanning larger dump trucks.



Calibration

The LVS is not an analogue measurement instrument and cannot be "calibrated" in the traditional sense – it does not include any facility for scaling the measurements up or down or setting a zero point. Calibration from a metrological point of view corresponds to the alignment of the LVS scan head to set the laser scanners in the correct position and orientation relative to the scan track that trucks pass over. However, measurement accuracy does not have a direct linear or non-linear relationship to scan head alignment which can in no way be used to "calibrate" the measurements.

Zero Indication

The LVS does not have a zero indication, only a ready indication. Zero reference is set for each individual truck or trailer body by scanning empty and recording an **empty vehicle profile** in the system database.

¹ See for example: NIST Handbook 44 (2012), section 5.58, *Multiple Dimension Measuring Devices (USA)*
OIML R129 (2000), *Multi-dimensional measuring instruments (OIML)*

² See for example: OIML R 134-1 (2006), *Automatic instruments for weighing road vehicles in motion and measuring axle loads (2006, OIML)*

³ See for example: NIST Handbook 44 (2012), section 4.45, *Dry Measures (USA)*
NMI Certificate of Approval No. 4/8/0A (2008), *Brim Measures for the Determination of the Volume of Flowable Solids (Australia)*

Validation Checks

The LVS performs many validity checks designed to prevent the system being used fraudulently or outside the limitations specified. If any validation checks fail, an error is generated and no result is displayed. The following are some of the validation checks performed by the system:

- On start-up the LVS will not enter ready-state if it detects gradient or camber of the scan area (relative to the scan head) are outside tolerance.
- LVS prevents recording empty truck/trailer trays of less than about 1.5m³ (2.0 yd³) capacity (or as otherwise specified) into the system database.
- No measurement output if covered load detected (e.g. tarpaulin covering tray).
- No measurement output if vehicle speed is outside limits or speed is too uneven.
- No measurement output if tray is scanned with hoist in fully or partially raised position.
- No measurement output if truck turns, drives off-centre or passes at too great an angle through the scan area.
- No measurement output if the basic visible dimensions of the 'empty' and 'load' trays do not match.
- LVS will not enter ready-state if high levels of dust, fog or other "visual pollution" are detected.
- No measurement output if high levels of dust, fog or other "visual pollution" are detected within scanned vehicle profile data.

Safety and Compliance

Declarations, certifications and reports relating to electrical and mechanical safety and Electro-Magnetic Compatibility (EMC) of the LVS system components are retained on file by LoadScan Ltd. The LVS design meets FCC (radiation), FDA (laser) and UL (electrical safety) requirements for import into the USA.

System Security

The LVS has built in security features to prevent tampering or misuse. These features include:

- Access to system software and settings is not possible without access procedures and passwords held by LoadScan Ltd.
- Laser scanner serial numbers are stored in the system computer so that scanners or computer cannot be replaced except by staff with the appropriate maintenance password and procedures.
- Access to user configuration and installation settings is limited by a 'System' password.
- Access to database functionality and historical measurement records can be limited by a 'User' password.

Database Records

Empty vehicle profiles are recorded into the system database as 'Reference Scans'. These form the zero references for each tray and have a 12-month expiry (or less as required by regional trade measurement authorities), after which they must be updated. Reference scans must also be updated any time that significant structural changes are made to the shape of a truck or trailer tray (e.g. adding or removing topper boards or cover systems). It is still possible to use existing reference scans after expiry, but 'REFERENCE SCAN EXPIRED' will be displayed or printed with all measurement indications.

Measurement Records

In addition to screen and sign indications and optional printed tickets, the LVS stores all results and additional details in log-files on electronic media. These files are secure and encrypted. They cannot be modified and create a secure audit trail. Non-encrypted copies of these files are available for download via network connection or USB drive without restriction (user password may be required). Additionally, for every scan, a record of the raw laser measurement data is saved to a file. These files provide a further audit trail and can be downloaded by LoadScan Ltd if necessary. They are automatically deleted after 60 days.

Extended Indication (Test Mode)

A password protected Extended Indication mode to assist in accuracy testing is available. In this mode the scale interval is $0.01\text{m}^3/\text{yd}^3$ across the full measurement range.

Access Log

An entry is automatically created in a secured access log file every time maintenance level configuration setting changes, software upgrades or scanner or computer hardware replacements are made. This log file can be downloaded (password required).

Sources of Measurement Error

A full theoretical error analysis is not feasible due to the complex interaction of thousands of variables. But the LVS has been extensively tested and the accuracy range demonstrated.

The metrologically significant factors that affect measurement accuracy are:

- Distance Measurements (Laser Scanners)
- Data Processing (Software)
- Scan Head Alignment (Installation)
- Environmental Conditions

Distance Measurements (Laser Scanners)

The laser scanners perform thousands of individual distance measurements every second.

- Rated absolute accuracy (typical): $\pm 12\text{ mm}$ ($\pm 0.47\text{ in}$).⁴
- The LVS application is affected by the relative error between individual points, not the absolute error relative to scanner zero location. This significantly reduces the effective error.
- No re-calibration of laser scanners is required. Built-in reference targets enable on-the-fly calibration which ensures that the measurement accuracy remains the same throughout the life time of the units.

The error in individual distance measurements has no relationship to the size of the truck/trailer bin, size of the load or instrument range settings.

In practice, each individual distance measurement at a single point can be modeled as largely independent from every other measurement with an equal probability of a positive or negative error within a range of statistical variance:

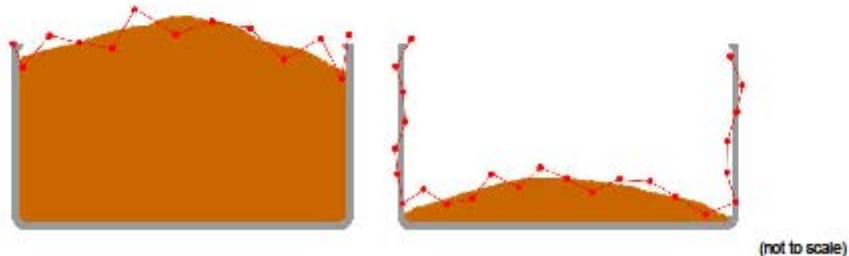

⁴ Manufacturer's specifications for current model used in LVS (Sick LMS511-20100).

Data Processing (Software)

There are thousands of variables involved in the measurement data processing and error can only be determined by testing. However, an integral part of the LVS design is that every metrologically significant software process determines a 'confidence level' based on its input data quality and generates a 'no measurement' error condition if the confidence level is not acceptable.

The LVS outputs no measurement if it is not confident of the result.

Software processing error is not directly dependent on the size of the truck/trailer bin, size of the load or instrument range settings. Error probability does however increase roughly proportionally to the visible upper surface area of the load. This surface area is constrained by the physical dimensions of the truck/trailer tray it is contained in. So absolute error tends to increase as load volume increases but level off at higher volumes.

Scan Head Alignment (Installation)

The LVS scan head must be installed in the correct position and orientation relative to the scan area (track) that trucks drive over and the scan area should be well defined. The type of mounting structure can vary and installation, alignment and track marking procedures do not require special skills or qualifications. They can be performed by the system operator.

The better the alignment of the scan head and quality of the scan track, the smaller the statistical variance in measurement error. But this is equally dependent on the position, angle and speed of the truck on the scan track during a scan and does not directly affect the magnitude or sign of average error.

Scan head alignment does not directly affect the direction of error (i.e. whether volume is over-reported or under-reported) and cannot be used to calibrate the instrument.

To ensure only good quality measurements, the LVS monitors the ground profile and analyzes scan data to determine if the scan head alignment is out or if truck position, angle or speed on the scan track is outside acceptable limits. The system has many built-in checks to automatically generate 'no measurement' error conditions in such cases. If the alignment is not correct or trucks are not following the designated path and speed then they will not be able to get measurements.

The process of aligning the scan head and defining the scan track does not significantly improve the measurement accuracy – it reduces the chances of getting "no measurement" error conditions.

Environmental Conditions

The effect of environmental conditions such as temperature, humidity, electro-magnetic interference and visibility on raw distance measurements is insignificant compared to other systematic errors and the laser scanners are rated for a very wide range of environmental conditions.⁵

Dense fog, steam or dust in the air can potentially block the view of the load surface and give false distance measurements. However, the LVS analyzes scan data to detect 'visual pollution' and generates a 'no measurement' error condition if this occurs.

The LVS does not attempt to measure a load if its view of the target is significantly obstructed.

⁵ Manufacturer's specifications for current model used in LVS (Sick LMS511-20100).

Accuracy Classification

LVS measurement error does not theoretically have a directly proportional relationship to measured load volume. However, in practice, in real world conditions, over a full range of truck designs, installation conditions and load types, absolute error magnitude increases roughly proportionally to load volume.

The following charts are indicative only. They are compiled from informal in-house accuracy testing and formal type approval testing results over a 12 year period. A variety of test load constructions, with varying degrees of uncertainty were used, test volumes are not evenly spaced and the number of measurements at each test volume varies. However the trend is clearly demonstrated:

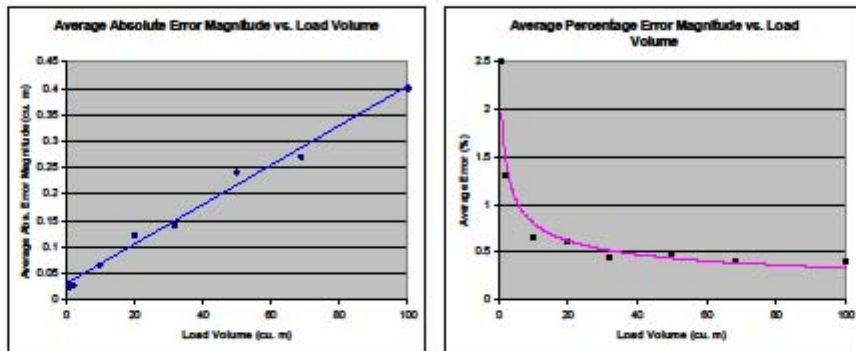

Absolute error magnitude tends to increase roughly proportionally to measured volume. Percentage error magnitude tends to a relatively constant (or slightly improving) value with increasing volume.

Where d is the scale interval, one possible best-fit MPE (tolerance) for the LVS is:

Maximum Permissible Error (MPE)
$\pm 1.00\%$ or $1.5d$ (whichever is the greater)

This is based on the 'Class 2' Weighing In Motion (WIM) accuracy class as specified by OIML⁶ but with the same MPE for Acceptance and Maintenance (the approach used by NMI for LVS type approval in Australia). The resultant MPE (in cubic metres, with d = 0.1) is as below:

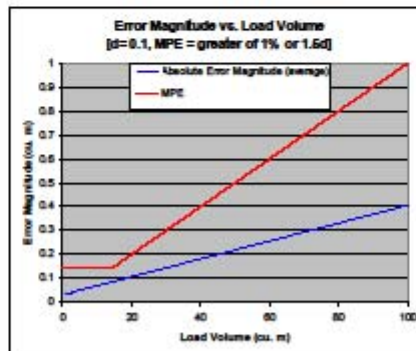

There are other possibilities. LVS type approval in New Zealand uses a stepped rather than percentage MPE.

⁶ See OIML R 134-1 (2006), Automatic instruments for weighing road vehicles in motion and measuring axle loads (OIML)

Test Methods

LVS Accuracy testing requires the generation of suitable test measures. A **test load** is an artificially generated reference volume, known to a suitable level of uncertainty, loaded onto a truck or trailer.

Current Methods

The following is a summary of methods currently used for generating test loads. LoadScan Ltd has more detailed written procedures on file. These methods can be combined.

Solid Test Load (Reference Standard)

A solid block or hollow shell of known external volume, in the approximate shape of a typical measurable load, may be loaded onto the test vehicle and used as a test load.



Advantages

- A permanent reference standard analogous to test weights used for scales.
- Volume does not change significantly over time.
- Easy to transport and store.
- Fast and practical solution.

Disadvantages

- Only suitable for test volumes that are small compared to instrument capacity.
- Requires a very flat tray floor as it is rigid and does not adapt to contours of test vehicle.

Multiple Brim Measure Loading

A rectangular bin or other brim measure of known capacity can be loaded with suitable material, and this material transferred to the test vehicle one or more times to create a test load.



Advantages

- Uses real load materials and generates realistic load profiles
- May be able to use resources available at test site

Disadvantages

- It is very difficult to control or determine true test load volume because load material compaction may not be the same in truck/trailer bin as in measuring container.
- The uncertainty increases significantly with load size due to the unpredictable compaction or settlement level of the cumulative load. This means it is only suitable for a small number of repeated brim measure transfers.

Levelled and Measured Load

Where the dimensions of the tray on the test vehicle are known, a test load of known volume can be generated by loading the tray to a set level below the tray top-sides and computing the volume from the known dimensions of the tray and the measured level of the load. The load material needs to be compacted or "shaken-down" before leveling to avoid the volume changing over time as the load settles. Additional load material should be added by the brim measure loading method or a solid test load put on top to create a more realistic load profile.

**Advantages**

- Uses real load materials.
- May be able to use resources available at test site.
- Can test up to larger volumes by this method.

Disadvantages

- Time consuming and requires lots of resources
- Requires suitable test vehicle to be identified in advance and available for testing.
- Unless the vehicle tray profile is very regular and simple the uncertainty in manual dimensional measurements may be too high.

False Floor Measured Load

A false floor (flat or profiled) may be constructed for a truck tray or custom test trailer of known dimensions. A solid test load or a measure of load material (brim measure loading) may be placed on top of this to generate a more realistic load profile. This is essentially the same as the Levelled and Measured Load method, except that the levelled load is generated by a false floor and the floor itself may be profiled to represent a load instead of flat.



Advantages

- Better control of surface profile than leveled and measured load so volume uncertainty is lower.
- Can test up to larger volumes by this method.

Disadvantages

- Time consuming and requires lots of resources
- False floor must be custom-built for a particular test vehicle.
- Unless the vehicle tray profile is very regular and simple the uncertainty in manual dimensional measurements may be too high.

Practical Constraints on Test Load Generation

Only approved test loads or methods should be used. General requirements for test loads are:

- True volume (conventional true value) must be determined by a verifiable method to a suitable level of uncertainty.
- Must be made of materials that cannot be easily influenced by environmental conditions.
- Must not be subject to loss or increase in volume over time.
- The shape of the test measure should reflect the shape of the loads to be measured.

Meeting these requirements is challenging, especially for larger volumes. There are practical constraints on:

- Technical construction method
- Ability to determine true volume
- Availability of suitable resources at test sites
- Time
- Cost
- Size
- Transportation and storage

Because of practical limitations it is not feasible to repeatedly generate test loads with volume known to the required level of uncertainty up to the maximum used capacity of the LVS (130m³/170yd³) beyond initial one-time type approval testing. However, as previously noted, the statistical error variance in the physical distance measurements which volume computation is based on has no relationship to actual load volume or instrument range settings and cannot be adjusted (calibrated). An LVS instrument is either working within its accuracy capabilities across its full range or it is faulty.

Confirmation of acceptable error at lower volumes is adequate to confirm the LVS is functioning correctly within its accuracy capabilities across its usable range.

In New Zealand, where the LVS has had type approval since 1999, the trade measurement authorities recognized this fact and the difficulties of attempting to create suitable test loads at high volumes. A certified solid test load (reference standard) with a volume of 2.10 m³ is used for all verification/certification testing. Approved maximum capacity is currently 85 m³ in New Zealand. This is adequate for the local market, but type approval testing has been successfully conducted up to 100 m³.

In regions where required maximum capacity is significantly higher, a 2.10 m³ test load may not be considered as adequate for testing LVS performance across the full range as a matter of principle.

For such cases we suggest a requirement to test to 25% of 'used capacity' where used capacity set per device for the particular application, within limits of type approval (up to 130 m³ / 170 yd³).

This is analogous to the 25% rule for scales with a capacity greater than 20,000 kg or 40,000 lb in the USA⁷.

Note also that the LVS is a portable instrument and that due to system validation checks accuracy is not significantly affected by site-specific installation. The LVS has been approved as a portable instrument in New Zealand since 2000.

The LVS does not require re-verification each time it is installed on a new site.

Alternative Standardized Method

Due to the practical limitations discussed, solid test load is the preferred method for accuracy testing. It is also the most familiar to trade measurement authorities as it involves the use of a permanent reference standard that can be verified, does not change significantly over time and can be stored and transported relatively easily, as for example test weights used to test truck scales.

However, large solid volumes designed to simulate a load on any test vehicle are impractical. Such test loads do not mold to the internal shape of the test bin like a real load and large size is impractical for transport, handling and storage.

LoadScan Ltd has developing a self-contained portable test system that does not require a separate test vehicle. The test vehicle is a large collapsible rectangular bin that is trailer mounted to simulate a truck or trailer body and has a moveable false floor. Combined with solid test loads this method is practical for testing up to medium volumes. The current design can test up to about 35 m³ (48 yd³).

We propose the following accuracy testing regime:

Type Approval Testing

Test to maximum capacity with a suitable number of intermediate steps as required by testing authorities.

Initial Verification (Acceptance)

Where used capacity is less than or equal to 30 m³ or 40 yd³ (depending on configuration):

- Test at zero and as close as possible to used capacity with intermediate tests as close as possible to minimum capacity and 50% of used capacity.

Where used capacity is greater than 30 m³ or 40 yd³ (depending on configuration):

- Test at zero and a maximum test volume at least the greater of 30 m³ / 40 yd³ or 25% of used capacity with intermediate tests as close as possible to minimum capacity and 50% of maximum test volume.

Testing to be conducted with self-contained test system as discussed above. Initial verification can be conducted at any suitable location and the instrument then moved from site to site as required without additional accuracy testing on each site.

Alternatively, if acceptable to trade measurement authorities, use same method as for In-Service Inspection (below). This is the approved regime in New Zealand and the most practicable.

In-Service Inspection (Maintenance)

Test at zero and at a test volume of at least 2 m³ or 3 yd³ (depending on system configuration) with solid test load(s) using any suitable test vehicle available on site.

⁷ See NIST Handbook 44 (2012), section 2.20, Scales, p2-31, Table 4, *Minimum Test Weights and Test Loads* (USA)

Suitability for Use

The LVS has proven to have a high degree of suitability for use within its application areas, especially where volumetric truck measure is the standard traded quantity.

Primary Application Areas

Civil Construction

- Bulk civil construction materials are specified and traded in volumetric quantities (m^3/yd^3)
- Portable measurement device on job sites (move from job to job)
- Monitor incoming construction materials such as rock aggregates, sand and soil
- Monitor outgoing materials such as excavated clay, soil etc

The LVS is well established in the civil construction industry in New Zealand. Some regional/city councils are requiring LVS units to be operated on their infrastructure jobs. Some construction companies are also requiring that their suppliers (quarries) must use an LVS if they wish to supply to their jobs.



Quarrying

- Mainly supply to the construction industry which works in volumetric quantities
- Measure outgoing product such as rock aggregates or sand
- Measure incoming "cleanfill" for land reclamation



Mining

- Often problematic measuring weight due to size of vehicles and environment - LVS is a non-contact, in-motion, low maintenance solution
- Measure unprocessed ore or coal, over-burden and construction materials used on site
- Monitor carry-back (haul-back) where load material stuck in "empty" vehicle trays



Mulch/Landscaping Products

- Bulk landscaping products are specified and traded in volumetric quantities ($m^3/yard^3$)
- Measure outgoing processed product
- Measure incoming raw ingredient supplies



Forestry

- Measure woodchip for pulp production (pulp/paper mills)
- Measure woodchip, sawdust or bark for burner fuel or sale to landscape product manufacturers
- Measure construction materials for forestry road building and maintenance



Waste/Recycling

- Landfill reclamation or capping material
- Bulk recycled materials in crushed, shredded or similar form
- Disaster Debris cleanup



Traditional Measurement Methods

Traditional methods for determining volumetric truck measure are often inaccurate but are widely practised.

Converting from Weight to Volume

Measuring and trading by weight and applying conversion factors to determine volume is often very inaccurate. The most obvious problem is that weight to volume ratio varies greatly, depending on the moisture content of the load material.

- Product can become wet because of rain, ground moisture or from deliberate wetting of stockpiles or truck loads to prevent dust. This practice which often occurs in quarries, works in the suppliers favour when measuring weight.
- If the material is wet when loaded, it can weigh considerably more at the point of loading than at the point of unloading because water run-off occurs in transit. Generally trading by weight is based on weight at the point of loading.
- Weight-to-volume conversion factors are typically computed on a dry day in carefully controlled conditions and do not necessarily reflect the weight-to-volume ratio of supplied materials.

Counting Bucket Loads

There are well recognized issues with counting loader bucket scoops as a method of determining volumetric truck measure.

- In practice operators do not load each bucket consistently to the same level. In fact the loader operator cannot generally see the scoop very well and certainly it is not practical to get out and strike-off (level) every scoop. This varies from loader to loader and from operator to operator.
- How the bucket is pushed into the stock-pile significantly affects the effective volume when transferred to truck/trailer. For example, pushing the bucket hard into the bottom of the stockpile produces a more compacted load than loosely scooping off the side of the stock-pile.
- Due to the self-compaction/settlement of heaped material under its own weight, multiple bucket loads may not equate to resultant cumulative heaped volumes in truck bins or in stockpiles generated from truck loads. This issue extends to differences in cumulative heaped volumes generated by small bucket loads or generated by large bucket loads because of material self-compaction within a single scoop.



Manual Surveying

Manual survey methods include:

- Level and measure (manual survey of levelled load in truck bin using tape measure)
- Survey single load on the ground after unloading
- Survey stockpile or 'cut and fill' volume (multiple loads)
- Unload truck load into a container of measured capacity.

These practices are widely used on a 'random check' basis but are very time consuming. A common complaint about the 'level and measure' process is that it requires re-shaping and walking on the load which effectively changes the load volume. Disputes also commonly arise over load settlement in transit. This is the change in volume of a load due to the product "bedding down" or "fluffing up" as a result of vibration, braking and bumps during transport. Often the differences between what the supplier claims was in a truck (in cubic metres or cubic yards) and what the buyer claims, is quite significant. Unloading a truck onto the ground and then re-loading it with the same material and manually surveying the load (level and measure) at the buyer end is one way to check if the supplier's claimed volume is accurate. This method results in a load that should be very close in volume to the original loaded volume at the point-of-loading, before travel influences.

It should also be noted that volumes computed from 'cut and fill' surveys or by surveying large stockpiles generated from multiple truck loads over a period of time may not result in quantities that match the cumulative total of all the truck loads as the surveyed material may be closer to "solid measure" (compacted) than "loose measure" which is the measured and traded quantity.

Counting Truck Loads

A truck or trailer capacity may be determined by manual measurement, but in practice trucks and trailers are not loaded exactly to capacity every time. They may be at less than capacity or loads may be heaped above the sides to greater than struck capacity. Loader/excavator operators often cannot see inside the truck bins as they are lower than the bin sides. It is also difficult to load into the bin corners with a loader or excavator. And in fact, in many cases trucks would be over-loaded if filled to capacity.

Accuracy Limitations in Volumetric Load Determination

Traditional methods of determining truck load volume are often not very reliable. However, this is only partly due to limitations of the measurement methods. The true volume of a given quantity of bulk loose solid material is not a constant value. Volume fluctuates slightly as a result of natural changes in product density due to changing compaction levels, moisture content and environmental conditions. For this reason it is simply not possible to determine a meaningful volume to the same level of accuracy as some other measures, such as weight. This is not covered by legislation or type approval processes, but trade measurement officers involved in testing and enforcement in the field will be familiar with these issues.

Measuring truck load volume to a degree of uncertainty significantly smaller than the magnitude of natural volume fluctuations does not generally provide more meaningful measurement.

Industry understands the limitations in volume determination. It is for example, common practise when trading by truck load or multiple bucket count to round to the nearest cubic metre or yard where a higher resolution measure is not meaningful.

One response to this problem is to trade by weight because this can be determined more accurately. But as discussed above, there are problems with trading by weight where volume is the quantity of interest.

An accurate measure of weight is often less meaningful than a less accurate measure of volume where volume is the quantity of interest

Key Advantages of the LVS

For trade by volumetric truck measure the best solution is a fair determination of the load volume as it sits in the truck at the time of measurement. This is what the LVS provides. Some key advantages of the LVS are:

- Avoids need to estimate by:
 - Converting from weight
 - Counting bucket scoops or truck loads
 - Manually measuring or guessing
- Fast, fully automated measurement
- Non-contact, so measuring the load does not interfere with the load volume.
- Measures actual load in truck or trailer bin regardless of theoretical bin capacity
- Equity of trade for seller and buyer

Our experience is that the LVS is accepted as providing a fair measure for all and acts to prevent many disputes that otherwise occur. Truck measure is a happy median between individual bucket loads and stockpiles and as such is equally equitable to seller and buyer. It is also our experience that suppliers such as quarries that use the LVS system may lose the small advantage of selling by more easily manipulated methods but their customers are happier.

The LVS is also a portable device, making it suitable for installation on construction sites and other short-term applications.

The ability of the LVS to automatically detect unsuitable measurement conditions, combined with the fact that no re-calibration is necessary makes the LVS very suitable for portable use and installation on different sites by trained operators without any special legal metrological qualifications.

Limitations and Potential Objections

Limitations of the LVS

- Limited to open-top trucks/trailers/bins
- Measurement of bulk loose solid materials only
- Measurement accuracy is limited
- The LVS is a visual inspection system. It is unable to operate in conditions of "visual pollution" and reports an error condition in cases of:
 - extreme dust
 - dense fog
 - dense clouds of steam rising from load material

Potential Objections to Trade Use of the LVS

Objection

Why should the LVS be approved for trade use when weighing instruments of similar measurement accuracy have been rejected?

Response

The following points should be considered:

- The LVS is not a weighing instrument. It should be compared to existing alternatives, not a different class of instrument.
- The LVS is not a general purpose measurement instrument. Unlike axle-weighers for example, which also have a lower accuracy classification, it cannot measure any type of product of any value. It is limited to measurement of bulk loose solids in open bin truck and trailer units. The application areas where volume is of interest for this type of load is mainly limited to relatively low value product.
- Volume measurement inherently has a higher uncertainty due to natural volume fluctuations. Measuring instantaneous volume to a higher degree of accuracy than the inherent uncertainty is not beneficial.
- The LVS provides a significant improvement in accuracy, consistency and convenience over current standard practices
- The accuracy is well within that demanded by industry itself (the buyers and sellers) for the types of transactions that LVS is used for.
- Accurate measurement of weight and conversion to volume from known bulk density does not provide a solution.

Objection

The LVS is not suitable for high value products due to accuracy limitation.

Response

The natural limitations of the device and industry requirements largely limit application to lower value products. Generally "high value" products that could be measured with the LVS are bulk dry powders with a high level of consistency in bulk density and so are suitable for measurement by weight and are traded by weight as standard.

Where considered necessary, trade measurement authorities can limit use. At a minimum the following suitability for use applies:

- a) Earth, sand, gravel and other similar excavated or mined materials
- b) Mulch, compost and other similar specialty mixes and primary raw constituent materials
- c) Woodchip, sawdust, bark and similar materials
- d) Unprocessed ore, coal or mining waste
- e) Bulk recycled materials in crushed, shredded or similar form
- f) Lumpy, irregular mixed materials only where traded as waste or debris

Objection

The LVS is only suitable for a limited range of vehicle types and material (product) types. Weight measurement does not have these limitations.

Response

True. The LVS is only suitable for measurement of bulk loose solids in open bin truck and trailer units. It is not intended as a general replacement for weight measurement. In fact it is often used in conjunction with weight measurement. It meets specific requirements of the industries where it is applied.

Objection

The LVS measures surface profile so voids (empty spaces) inside load are included in the measured volume.

Response

- In general the LVS is only intended for the measurements of bulk particulate materials with relatively small particle size so large voids do not occur.
- If the material is used in the same form it is measured in then it will have the same volumetric properties, including voids, in use.
- If the material is crushed/ground or otherwise modified after measurement then it becomes a different product with different properties.
- In special cases such as measurement of debris the material may be lumpy and contain significant voids, but the volume of interest includes the voids.

Objection

Some traders will believe they can make more money selling by the bucket count or weighing wet material so it is not in their interest to adopt this technology.

Response

Firstly, it is the trader's choice to use the LVS or not. Secondly, the point of measurement is the point of payment so the measurement needs to be as equitable as possible (fair to buyer and seller). Of course rates (i.e. cost per cubic metre or yard) also need to reflect the condition of the traded material at the point of measurement.

Appendix G

NIST Handbook 44 – Multiple Dimension Measuring Devices

Item 358-1:

Load Volume Scanner, Proposals for Integration into NIST Handbook 44

Load Volume Scanner

Proposals for Integration into NIST Handbook 44

A submission to NCWM

Author:

Adrian Ruthe

Technical Manager

LoadScan Ltd, New Zealand

Contents

<u>Introduction</u>	2
<u>Applicability of MDMD Code to the LVS</u>	3
<u>Tolerances</u>	3
<u>Limitations on Use</u>	4
<u>Test Procedures – Accuracy Testing</u>	5
<u>Test Procedures – Disturbance Testing</u>	7
<u>Appendix - LVS Type Approval History Outside of the USA</u>	8
<u>New Zealand</u>	8
<u>Australia</u>	9

Introduction

At the time of writing, the *LoadScan* Load Volume Scanner (LVS) has been granted ‘Developing Item’ status by NCWM and it is now up to LoadScan as the device manufacturer to prepare specific language for NIST Handbook 44 amendment. **Multiple Dimension Measuring Devices (MDMD)** has been identified as the most suitable classification into which to incorporate the LVS and our aim is to prepare amendments to the MDMD specification, or if not feasible, to submit a new instrument specification modeled on MDMD.

At this stage formal language has not been developed. This document identifies only the most significant areas where the MDMD code cannot be directly applied to the LVS and proposes solutions for consideration by the relevant authorities. Other minor discrepancies between LVS and MDMD can be readily addressed by minor amendments to the MDMD code. Formal code will be developed and minor discrepancies between LVS and MDMD addressed only when consensus and approval in principle has been reached on the key issues.

It is strongly recommended to read the appendix to this document, *LVS Type Approval History Outside of the USA* before considering the proposals below. Some topics are also discussed in more detail in the supporting document to this submission, *Load Volume Scanner - General Metrology, Test Methods and Suitability for Use* (revision of a previously submitted document, not US specific).

Applicability of MDMD Code to the LVS

The LVS has some notable similarities to MDMD:

- MDMD typically uses the same non-contact laser measurement technology as the LVS.
- MDMD and LVS both compute volume from a set of linear dimensional measurements.
- MDMD and LVS both typically measure moving targets passing below the measurement elements of the instrument.
- MDMD and LVS both measure the target relative to a zero reference profile formed by the surface or container that carries the object or load being measured.

There are also some notable differences:

- MDMD measures discrete objects (boxes, packages etc) whereas LVS measures bulk loose flowable solid materials (materials that form heaps).
- MDMD uses a set of rules to compute the volume of a hexahedron occupied by the measured object whereas LVS measures the actual volume of the heap of measured material (“loose” volume based on the surface contour).
- MDMS intended for calculating freight, storage, or postal charges based on the dimensions and/or volume occupied by the object whereas LVS intended for determining quantities of material where that material is traded by volume.
- MDMS zero reference is generally a flat conveyor-belt or table top and can be treated as a static 2D profile whereas LVS zero reference is the entire load-bearing container (truck trailer or bin) that moves with the measured load and must be treated as a moving 3D profile.

So consider *NIST Handbook 44, Section 5.58. Multiple Dimension Measuring Devices, Application:*

A.2. Other Devices Designed to Make Multiple Measurement Automatically to Determine a Volume. – Insofar as they are clearly applicable, the provisions of this code apply also to devices designed to make multiple measurements automatically to determine a volume for other applications as defined by Section 1.10. General Code paragraph G-A.1. Commercial and Law-Enforcement Equipment.

This applies to the LVS. However, the need for an instrument description that more explicitly describes the LVS principle of operation and application should be considered, if only to define a clear sub-category that variations in the MDMD code can be specifically applied to. As the manufacturer of a specific instrument, it may not be appropriate for us to define the limitations or terminology of this specific sub-category. But for the purposes of this document “LVS” will refer to such a sub-category of MDMD instruments that the Load Volume Scanner belongs to.

Tolerances

NIST Handbook 44, Section 5.58. Multiple Dimension Measuring Devices, Tolerances:

T.3. Tolerance Values. – The maintenance and acceptance tolerance values shall be ± 1 division.

It is not be feasible for the LVS to meet these requirements (and the requirements of paragraph S.1.5 and T.2.3) without a multi-interval implementation and choices of division sizes for each interval that may not be suitable for intended application in some cases.

We propose the following variation for instruments of the LVS class:

The maintenance and acceptance tolerance values shall be ± 1 division or 1 percent of measured load; whichever is the greater.

In practice, the minimum feasible scale division for the LVS is 0.1 cubic meter or 0.1 cubic yard, dependent on regional configuration. To meet the requirements of the US bark and mulch industries the maximum capacity will need to be 130 cubic meters or 170 cubic yards per individual truck bin.

We realize that this effectively puts the LVS in a lower accuracy classification than allowed for other classes of instrument such as weigh scales used for trade.

The closest comparable class I can find in NIST Handbook 44 for the volumetric measure of dry solid material is Dry Measures (section 4.45). Obviously the LVS does not fit into this classification. However, as a point of note, the maintenance tolerances for a 1 bushel dry measure (the largest measure specified) are 50 cubic inches in excess and 25 cubic inches in deficiency with acceptance tolerances being one-half the maintenance tolerances (*NIST Handbook 44, section 4.45. Dry Measures, Tolerances*). Averaging over “in excess” and “in deficiency” this is equivalent to maintenance and acceptance tolerances of approximately **1.74%** and **0.87%** respectively. And by extension, the same tolerances apply to quantities resulting from multiple 1 bushel dry measures.

What must be considered is the intended purpose and suitability for use of the instrument. This is discussed in the supporting document to this submission, *Load Volume Scanner - General Metrology, Test Methods and Suitability for Use*.

Limitations on Use

Consider the following excerpts from *Handbook 130*:

2.18.2. – All mulch shall be sold, offered, or exposed for sale in terms of volume measure in SI units in terms of the **cubic meter** or liter or in inch-pound units in terms of the **cubic yard or cubic foot**.

2.29 (a) – Top soil, fill dirt, aggregate or chipped rock, sand (including concrete and mortar sand), decomposed granite, landscape type rock, and cinders must be sold by the **cubic meter or cubic yard** or by weight.

The LVS was designed to meet the requirements of specific industries such as the mulch and civil construction industries and their suppliers, who either trade by volume already, or would prefer to, if suitable measurement equipment were available. The LVS is intended to meet the requirements of these industries and is not intended as a general use instrument to replace truck scales. As such we propose the following limitations on use for instruments of the LVS class:

- a) **To soil, clay, sand, aggregate or chipped rock and similar excavated or mined materials**
- b) **Mulch, compost, specialty horticultural and landscaping mixes and primary constituent materials thereof.**
- c) **Woodchip, sawdust, bark and similar materials**
- d) **Coal, unprocessed ore, mining waste**
- e) **Bulk recycled or waste materials in crushed, shredded or similar form**
- f) **Lumpy, irregular mixed materials only where traded as waste or debris**

A shorter list may be possible if worded so as to be suitably inclusive.

Test Procedures – Accuracy Testing

NIST Handbook 44, Section 5.58. Multiple Dimension Measuring Devices, Notes:

N.1.1. General. – The device shall be tested using test standards and objects of known and stable dimensions.

N.1.4.1. Test Objects. – Verification of devices may be conducted using appropriate test objects of various sizes and of stable dimensions. Test object dimensions must be known to an expanded uncertainty (coverage factor $k = 2$) of not more than one-third of the applicable device tolerance. The dimensions shall also be checked to the same uncertainty when used at the extreme values of the influence factors. The dimension of all test objects shall be verified using a reference standard that is traceable to NIST (or equivalent national laboratory) and meet the tolerances expressed in NIST Handbook 44 Fundamental Considerations, paragraph 3.2. (i.e., one-third of the smallest tolerance applied to the device).

Due to the practical difficulties in generating LVS test loads of known and stable dimensions, as discussed in the Test Methods section of the supporting document *Load Volume Scanner - General Metrology, Test Methods and Suitability for Use*, we propose that the system of test objects/standards used for certification testing in Australia be adopted (see notes and photos in *Australia* section of the appendix to this document, *LVS Type Approval History Outside of the USA*). This system combines a rectangular bin trailer with moveable false floor and rigid test objects and is suitable for generating test loads with volume known to the required level of expanded uncertainty for the tolerances proposed above. The dimensions of all test objects/bins can readily be verified with a tape measure (NIST traceable reference standard).

Code language to facilitate this could be along the lines of:

Test objects approximating the shape of a heaped load and with geometry that facilitates determination of volume by measurement of linear dimensions may be used to generate test loads in a suitable mobile test container. A raised floor or rigid objects covering the entire test container floor such that no edges are visible may be placed in the test container, supporting the test objects, to generate test loads at larger volumes.

This method of using dedicated test equipment is only suitable for generating test volumes of a limited size. At this stage we have only used this method to test up to 35 cubic meters (45 cubic yards).



NIST Handbook 44, Section 5.58. Multiple Dimension Measuring Devices, Notes:

N.1.4. Test Object Size. – Test objects may vary in size from the smallest dimension to the largest dimension marked on the device, and for field verification examinations, shall be an integer multiple of “d.”

This does not explicitly require testing to maximum capacity. As discussed in the supporting document to this submission, *Load Volume Scanner - General Metrology, Test Methods and Suitability for Use*, correct operation within accuracy capability for the LVS can theoretically be confirmed at any test volume. We propose the following variation for LVS class instruments:

Test loads shall vary in size from zero (empty test container) to at least 25 % of instrument capacity including minimum capacity and at least one other intermediate volume.

For a maximum capacity of 130 cubic meters or 170 cubic yards this would be feasible. This is similar to the requirement for scales with a capacity above 20,000kg or 40,000lb as specified in *NIST Handbook 44, Section 2.2*.

Scales, Notes, Table 4. It may be considered necessary to specify the 25% rule for instruments with a capacity above a set value as for scales. See further discussion of a *Standardized Test Method* and other test methods in the supporting document to this submission, *Load Volume Scanner - General Metrology, Test Methods and Suitability for Use*.

Note that in New Zealand all official certification/verification testing is performed with a single rigid test object of 2.1 cubic meters, which equates to 3.2% of approved maximum capacity of 65m³ per bin (see appendix to this document, *LVS Type Approval History Outside of the USA*).

Type approval testing may need to be conducted to maximum capacity. This is possible by finding a suitable, very large truck-trailer and manually dimensioning this trailer in detail and generating test loads by a combination of methods. This is very time consuming and requires a lot of resources. This is feasible for one-time type approval testing but not for regular verification testing.

Additionally, it is not practical to generate larger test loads to an integer multiple of the scale interval “d” by the proposed test method. However, the LVS instrument has a test mode that displays measurements at a higher resolution, allowing accurate comparison between measurement indications and computed test load volumes. We propose a requirement along the lines of the following:

The instrument shall have a special test mode that can only be activated for accuracy testing and causes all measurement indications to be output to a resolution of at least 10 times “d”.

Test Procedures – Disturbance Testing

It is simply not feasible to put a standard LVS system in an environmental chamber and perform disturbance tests for type approval. Requirements for any laboratory testing will need to be discussed. Please see the *Australia* section of the appendix to this document, *LVS Type Approval History Outside of the USA* for notes on how this was handled for type approval in Australia. We propose a similar approach be adopted for NTEP testing.

APPENDIX - LVS TYPE APPROVAL HISTORY OUTSIDE OF THE USA

NEW ZEALAND

The LVS was granted type approval in New Zealand in 1999. Approval was based loosely on the OIML specification for Automatic Catchweighing Instruments (OIML R51-1). This was prior to the release in 2000 of the OIML specification for Multi-Dimensional Measuring Instruments (OIML R129) which is the equivalent of MDMD. The New Zealand *Certificate of Approval 1556* (type approval) is available for reference. No type approval guide document exists.

The following are some specific points of note.

1. Initial approval was only up to 20m³ load per bin (maximum capacity) with limitation to measurement of sand, gravel and small rock. However, Trading Standards New Zealand (TSNZ) monitored our systems for some time, were happy with the performance and since 2007 approval has been up to 65m³ per bin, for any solid material with a particulate size of less than or equal to 200mm. Minimum capacity is 0.5m³.
2. We have successfully performed field testing with the TSNZ up to 105m³ per bin but have not applied for a type approval variant up to this volume as it is not currently required for the size of trucks operated in New Zealand.
3. We have about 50 trade-legal certified LVS systems operating in New Zealand. There have been no complaints to TSNZ in the 13 years since initial type approval.
4. The accuracy class specified is a variant on Catchweigher class Y(b). For our implementation with a scale interval of 0.1m³ this is similar to US weight class IIII up to 40m³ and better than class IIII above 40m³.
5. Type approval does not require accuracy testing up to maximum capacity. This recognizes the fact that due to the principle of operation of the LVS, measurement accuracy can effectively be confirmed at any volume (see support document *Load Volume Scanner - General Metrology, Test Methods and Suitability for Use*). Type evaluation testing was of course conducted to maximum capacity.
6. Several methods for generating test loads are approved. However LoadScan maintains a single 2.1m³ test load (reference standard) for all certification/verification testing. This is a rigid profile approximating the shape of a load. The test load is annually re-certified by TSNZ. Volume is determined by the displacement of water in a rectangular tank.



AUSTRALIA

The LVS was granted type approval in Australia in 2010. Type Approval was based as closely as practical on the OIML specification for Multi-Dimensional Measuring Instruments (OIML R129). Before conducting type evaluation the Australian National Measurement Institute (NMI) prepared a type evaluation guide called *Guidelines for the Pattern Approval of Systems used for the Determination of Load Volumes*. This is based primarily on the Australian general guidelines for pattern approval and the OIML specification for Multi-Dimensional Measuring Instruments (OIML R129). This document and *Certificate of Approval No 13/1/15* (type approval) are available for reference. The following are some specific points of note.

1. Current approval is only up to 35m³ load per bin. This is not a limitation imposed by NMI but the result of the resources we had available when field evaluation was conducted only being suitable for loads up to 35m³. This is adequate to cover the requirements of the construction and most other industries except the mulch industry. Minimum capacity is 1.0m³. Further testing will be conducted with NMI for higher volumes.
2. The LVS is approved for measurement of *'flowable solids such as sand, soil, gravel and agricultural materials'*.
3. Approval requires accuracy testing "near (as close as practical)" to maximum capacity. The volume of test loads must be determined to an expanded uncertainty of one fifth of the maximum permissible error or less, in line with the OIML specification for Multi-Dimensional Measuring Instruments (OIML R129).
4. The approval certificate does not require an accuracy class to be marked on the instrument. Only maximum permissible errors (tolerances) are specified. NMI's view is that no formal accuracy classes exist for this type of instrument so it does not make sense to mark a class. This also allows the instrument to be tested to different accuracy "classes" within the maximum tolerances specified, depending on the intended application and the type/quality of test loads available.
5. The maximum tolerances specified in the approval are based on weight class 5 from the OIML specification for *Automatic instruments for weighing road vehicles in motion and measuring axle loads* (OIML R134). This is a low accuracy class (basically a 2.5% class). The reason for this is not the accuracy

of the LVS system but the difficulty in generating test loads with sufficiently accurately known volume (expanded uncertainty 1/5th MPE) to perform accuracy testing up to maximum capacity. However, the LVS may be also be tested to class 2 (1% class) if suitable test loads/standards are available.

6. It is up to individual state authorities to specify any additional limitations on use, depending on the accuracy class the LVS is tested to.
7. LVS approval requires that all measured volume indications are accompanied by a statement that *the volume indicated is that at the time of measurement*. This reflects the fact that flowable solid volumes can fluctuate slightly over time (see support document ***Load Volume Scanner - General Metrology, Test Methods and Suitability for Use***).
8. For practical reasons laboratory testing in an environmental chamber for type approval was conducted with a modified mounting system for the LVS to allow it to fit into the test chamber. The testing was also conducted with static (non-moving) test profiles and a modified version of the system software. NMI took the approach that the ability of the LVS software to compute accurate volumes from the raw laser distance measurement data can be determined by field-testing and that for laboratory testing it is only necessary to test the ability of the laser distance measuring components to provide suitable data for the software to process. A variation on the disturbance and other tests given in the OIML specification for Multi-Dimensional Measuring Instruments (OIML R129) were conducted.



Custom-mounted LVS in environmental test chamber, NMI, Sydney, Australia

9. LoadScan maintains a ‘test trailer’ and a 1.0m³ test load (reference standard) for certification testing in Australia. The test trailer is a dimensionally accurate rectangular bin with a false floor that can be positioned at different heights to simulate different levels of loading. The 1.0m³ test load is placed on the trailer floor or false floor to create a more realistic load profile and to test at minimum capacity. The trailer is fully mobile and can be disassembled. The 1.0m³ test load is dimensionally accurate and design is based on basic geometrical shapes so that its volume can be determined by manual measurement with tape measure. Test load volumes can be determined with enough accuracy to test to class 2 (1% class) with this equipment.







Appendix H

NIST Handbook 44 – Developing Items

Item 360-3:

Electric Vehicle Fueling and Submetering

This draft code is currently under development by the USNWG; this draft is NOT yet ready for consideration by the NCWM. Updated versions will be posted on the NIST website as work by the USNWG progresses.

Draft NIST Handbook 44 Device Code Requirements for Electric Vehicle Fueling and Submetering

This tentative code has only a trial or experimental status and is not intended to be enforced. The requirements are designed for study prior to the development and adoption of a final code. Officials wanting to conduct an official examination of a device or system are advised to see paragraph G-A.3. Special and Unclassified Equipment.

(Tentative Code Added 20XX)

A. Application

A.1. General. – This code applies to electronic and mechanical devices, accessories, and systems used for the measurement of electricity dispensed as a vehicle fuel and in other commercial electricity sub-metering applications wherein a quantity determination or statement of measure is used wholly or partially as a basis for sale or upon which a charge for service is based.

A.2. Exceptions. – This code does not apply to:

- (a) This code does not apply to the use of any measure or measuring device used by a public utility in connection with measuring electricity subject to the jurisdiction of the Public Utilities Commission.
- (b) Devices used solely for dispensing a product in connection with operations in which the amount dispensed does not affect customer charges.
- (c) The wholesale delivery of electricity.

A.3. Additional Code Requirements. – In addition to the requirements of this code, Electricity-Measuring Devices shall meet the requirements of Section 1.10. General Code.

A.3.1. Dual-Purpose Electric Vehicle Supply Equipment (EVSE) and Timing Devices. – A device that is used for both the sale of electricity as vehicle fuel and the sale of other separate time-based services (e.g., vehicle parking) shall meet the requirements Section 5.55. Timing Devices. in addition to the requirements of this code.

A.4. Type Evaluation. – The National Type Evaluation Program (NTEP) will accept for type evaluation only those devices that comply with all requirements of this code.

A.5. Meter Type Notation. – Code sections and subsections with an [EM] notation apply to electronic meters only. Code sections and subsections with a [MM] notation apply to mechanical meters only. Code sections and subsections without [EM] or [MM] notation apply to both meter types.

S. Specifications

S.1. Indicating and Recording Elements.

S.1.1. Electric Vehicle Supply Equipment (EVSE). – A device used to charge electric vehicles shall be of the computing type and shall indicate the electrical energy, the unit price, and the total price of each delivery.

S.1.2. EVSE Indicating Elements. – A device used to charge electric vehicles shall include an indicating element that continuously displays measurement results relative to quantity and total price. Indications shall be clear, definite, accurate, and easily read under normal conditions of operation of the device. All indications and representations of electricity sold shall be clearly identified and separate from other time-based fees indicated by a dual-purpose device that is used for both the sale of electricity as vehicle fuel and the sale of other separate time-based services (e.g., vehicle parking).

S.1.3. EVSE Units.

S.1.3.1. EVSE Units of Measurement. – Deliveries used to charge electric vehicles shall be indicated and recorded in megajoules (MJ) or kilowatt-hours (kWh) and decimal subdivisions thereof.

S.1.3.2. Numerical Value of Quantity-Value Divisions. – The value of an interval (i.e., increment or scale division) shall be equal to:

- (a) 1, 2, or 5; or
- (b) a decimal multiple or submultiple of 1, 2, or 5.

Examples: quantity-value divisions may be 10, 20, 50, 100; or 0.01, 0.02, 0.05; or 0.1, 0.2, or 0.5; etc.

S.1.3.3. Maximum Value of Quantity-Value Divisions. – The maximum value of the quantity-value division shall not be greater than 0.5% of the minimum measured quantity.

S.1.3.4. Values Defined. – Indicated values shall be adequately defined by a sufficient number of figures, words, symbols, or combinations thereof. An indication of “zero” shall be a zero digit for all displayed digits to the right of the decimal mark and at least one to the left.

S.1.4. EVSE Value of Smallest Unit. – The value of the smallest unit of indicated delivery by an EVSE, and recorded delivery if the EVSE device is equipped to record, shall not exceed the equivalent of 3.6 MJ or 1 kWh.

S.1.5. [MM] Submeter Register. – A meter register shall clearly indicate the number of kilowatt-hours measured by the meter. The register ratio shall be indicated on the front of the registers that are not an integral part of the meter nameplate. Means shall be provided for the tenant to read the meter register.

S.1.6. [EM] Submeter Watthour Indications.

S.1.6.1. Customer Indicating Element. – All submeters in a service system shall have an individual customer indicating element on or at the meter and the minimum value shall not exceed one kilowatt hour.

S.1.6.2. Test Constant. – All submeter systems shall be capable of indicating at least one watthour test constant (K_t) output indication but not more than 20 watthour test constant output indications.

Means for indicating watthour test constant output indications include but are not limited to: decimal point, contrasting display colors, shorting link, or a means for visual flashing pulse counts.

S.1.6.3. Indicating Element Value. – The minimum indicating element value (unit of measure) shall be conspicuously identified on or near the customer indicating element.

S.1.6.4. Segments. – A segmented digital indicating element shall have an easily accessible provision for checking that all segments are operational.

S.1.6.5. Real-time Indicating Element. – If the indicating element is not on continuously, it shall be accumulated continuously so that real-time measurement is indicated during activation.

S.1.7. Multiple Submeter Indicating Elements. – An indicating or combination indicating-recording element coupled to two or more meter systems shall be provided with means to prohibit indication of information from any meter system not selected, and shall be provided with automatic means to indicate clearly and definitely which meter system is associated with the indication.

S.2. EVSE Operating Requirements.

S.2.1. EVSE Return to Zero.

(a) The primary indicating and the primary recording elements of a device used to charge electric vehicles, if the device is equipped to record, shall be provided with a means for readily returning the indication to zero either automatically or manually.

(b) It shall not be possible to return primary indicating elements, or primary recording elements, beyond the correct zero position.

S.2.2. EVSE Indicator Reset Mechanism. – The reset mechanism for the indicating element of a device used to charge electric vehicles shall not be operable during a delivery. Once the zeroing operation has begun, it shall not be possible to indicate a value other than the latest measurement, or “zeros” when the zeroing operation has been completed.

S.2.3. EVSE Provision for Power Loss.

S.2.3.1. Transaction Information. – In the event of a power loss, the information needed to complete any transaction in progress at the time of the power loss (such as the quantity and unit price, or sales price) shall be determinable for at least 15 minutes at the device or at the console if the console is accessible to the customer.

S.2.3.2. User Information. – The device memory shall retain information on the quantity of fuel dispensed and the sales price totals during power loss.

S.2.4. EVSE Indication of Unit Price and Equipment Level Identity.

S.2.4.1. Unit Price. – A computing or money-operated device shall be able to indicate on each face the unit price at which the device is set to compute or to dispense.

S.2.4.2. Equipment Level. – A device shall be able to conspicuously indicate on each side the equipment level (i.e., Level 1, Level 2, or Level 3) of the device.

S.2.4.3. Selection of Unit Price. – When a product is offered for sale at more than one unit price through a computing device, the selection of the unit price shall be made prior to delivery using controls on the device or other customer-activated controls. A system shall not permit a change to the unit price during delivery of a product.

S.2.4.4. Agreement Between Indications. – All quantity, unit price, and total price indications within a measuring system shall agree for each transaction.

S.2.5. EVSE Money-Value Computations. – A computing device shall compute the total sales price at any single-purchase unit price for which the product being measured is offered for sale at any delivery possible within either the measurement range of the device or the range of the computing elements, whichever is less.

S.2.5.1. Money-Value Divisions, Digital. – A computing type device with digital indications shall comply with the requirements of paragraph G.S.5.5. Money-Values, Mathematical Agreement, and the total price computation shall be based on quantities not exceeding 0.36 MJ or 0.1 kWh.

S.2.5.2. Auxiliary Elements. – If a system is equipped with auxiliary indications, all indicated money value and quantity divisions of the auxiliary element shall be identical with those of the primary element.

S.2.5.3. Indication of Quantity and Total Price. – When a delivery is completed, the total price and quantity for that transaction shall be indicated on the face of the device for at least five minutes or until the next transaction is initiated by using controls on the device or other user-activated controls.

S.2.6. EVSE Recorded Representations. – Except for fleet sales and other price contract sales, a printed receipt providing the following information shall be available through a built-in or separate recording element for all transactions conducted with point-of-sale systems or devices activated by debit cards, credit cards, and/or cash. The printed receipt shall contain the following information for electricity delivered by the device:

- (a) the total quantity of the delivery;
- (b) the unit price;
- (c) the total computed price of the electricity sale;
- (d) the EVSE level (i.e., Level 1, Level 2, or Level 3) by name, symbol, abbreviation, or code number;
- (e) any additional separate charges included in the transaction (e.g., charges for parking time); and
- (f) the final total price of the complete transaction including all items.

For systems equipped with the capability to issue an electronic receipt, the customer may be given the option to receive the receipt electronically (e.g., via cell phone, computer, etc.).

S.2.7. Indication of Delivery. – The device shall automatically show on its face the initial zero condition and the quantity delivered (up to the capacity of the indicating elements).

S.3. Design of Measuring Elements and Measuring Systems. – Except as otherwise noted within NIST Handbook 44, meters shall meet all applicable design requirements of the latest published ANSI C12.1 Code for Electricity Metering.

S.3.1. Metrological Components. – A meter system shall be designed and constructed so that metrological components are adequately protected from environmental conditions likely to be detrimental to accuracy. Components shall be designed to prevent undetected access to adjustment mechanisms and terminal blocks by providing for application of a physical security seal or an Audit Trail.

S.3.2. Terminals. – The terminals of the meter shall be arranged so that the possibility of short circuits while removing or replacing the cover, making connections, or adjusting the meter, is minimized.

S.3.3. Adjustment Means. – A measuring system shall be provided with means to change the ratio between the indicated quantity and the quantity of electricity measured by the meter.

S.3.4. Provision for Sealing. – Adequate provision shall be made for an approved means of security (e.g., data change audit trail) or physically applying security seals in such a manner that no adjustment may be made of:

- (a) each individual measurement element;
- (b) any adjustable element for controlling voltage or current when such control tends to affect the accuracy of deliveries;
- (c) any zero adjustment mechanism; and
- (d) any metrological parameter that detrimentally affects the metrological integrity of the device or system.

When applicable, the adjusting mechanism shall be readily accessible for purposes of affixing a security seal. Audit trails shall use the format set forth in Table S.3.4. Categories of Device and Methods of Sealing.

Table S.3.4. Categories of Device and Methods of Sealing	
Categories of Device	Method of Sealing
<p>Category 1: No remote configuration capability.</p>	<p>Seal by physical seal or two event counters: one for calibration parameters and one for configuration parameters.</p>
<p>Category 2: Remote configuration capability, but access is controlled by physical hardware.</p> <p>The device shall clearly indicate that it is in the remote configuration mode and record such message if capable of printing in this mode or shall not operate while in this mode.</p>	<p>The hardware enabling access for remote communication must be on-site. The hardware must be sealed using a physical seal or an event counter for calibration parameters and an event counter for configuration parameters. The event counters may be located either at the individual measuring device or at the system controller; however, an adequate number of counters must be provided to monitor the calibration and configuration parameters of the individual devices at a location. If the counters are located in the system controller rather than at the individual device, means must be provided to generate a hard copy of the information through an on-site device.</p>
<p>Category 3: Remote configuration capability access may be unlimited or controlled through a software switch (e.g., password).</p> <p>The device shall clearly indicate that it is in the remote configuration mode and record such message if capable of printing in this mode or shall not operate while in this mode.</p>	<p>An event logger is required in the device; it must include an event counter (000 to 999), the parameter ID, the date and time of the change, and the new value of the parameter. A printed copy of the information must be available through the device or through another on-site device. The event logger shall have a capacity to retain records equal to 10 times the number of sealable parameters in the device, but not more than 1000 records are required. (Note: Does not require 1000 changes to be stored for each parameter.)</p>

S.3.5. [EM] Meter-Control Program. – The meter-control program shall be an integral part of the meter's firmware read-only memory that cannot be changed in its operating environment. This section does not apply to electronic meters that do not utilize a meter-control program.

S.3.6. [EM] Data Storage and Retrieval.

Wathour data accumulated and indicated shall be permanent and accessible.

- (a) Values indicated or stored in memory shall not be affected by electrical, mechanical or temperature variations, radio-frequency interference, power failure, or any other environmental influences to the extent that accuracy is impaired.
- (b) Memory and/or display shall be recallable for the life of the meter. A replaceable battery shall not be used for this purpose.

S.3.7. Temperature Range for Metering Components. - Meters shall be accurate and correct over the temperature range of $-20\text{ }^{\circ}\text{C}$ to $+50\text{ }^{\circ}\text{C}$ ($-4\text{ }^{\circ}\text{F}$ to $122\text{ }^{\circ}\text{F}$). If the meter or any measuring system components are not capable of meeting these requirements, the temperature range over which the system is capable shall be stated on the NTEP CC, marked on the device, and installations shall be limited to the narrower temperature limits.

S.3.8. Zero-Set-Back Interlock, Retail EVSE Devices. – A device shall be constructed so that:

- (a) when the device is shut-off at the end of a delivery an automatic interlock prevents a subsequent delivery until the indicating element and recording elements, if the device is equipped and activated to record, have been returned to their zero positions; and
- (b) it shall not be possible to return the vehicle connector to its starting position unless the zero-set-back interlock is engaged or becomes engaged.

For systems with more than one device supplied by a single measuring element, an effective automatic control in each device prevents product from being delivered until the indicating elements on that device are in a correct zero position; or

For systems with more than one connection supplied by a single measuring element, effective automatic means must be provided to prevent product from being delivered until the indicating element(s) corresponding to each connection are in a correct zero position.

S.4. Connections.

S.4.1. Diversion of Measured Electricity. – No means shall be provided by which any measured electricity can be diverted from the measuring device.

S.4.2. Directional Control. – If a reversal of energy flow could result in errors that exceed the tolerance for the minimum measured quantity, effective means, automatic in operation to prevent or account for the reversal of flow shall be properly installed in the system. (See N.7. Minimum Measured Quantity)

S.5. Markings. – The following identification and marking requirements are in addition to the requirements of Section 1.10 General Code, paragraph G-S.1. Identification.

S.5.1. Location of Marking Information; EVSE. – The marking information required in General Code, paragraph G S.1. Identification shall appear as follows:

- (a) within 60 cm (24 in) to 150 cm (60 in) from ground level;
- (b) either internally and/or externally provided the information is permanent and easily read; and accessible for inspection; and

- (c) on a portion of the device that cannot be readily removed or interchanged (e.g., not on a service access panel).

Note: The use of a key or tool to access internal marking information is permitted for retail electricity-measuring devices.

S.5.2. Device Identification and Marking Requirements. – In addition to all the marking requirements of Section 1.10 General Code, paragraph G-S.1. Identification, each device shall have the following information conspicuously, legibly, and indelibly marked on the nameplate or register, if applicable:

- (a) the accuracy class of the device as specified by the manufacturer consistent with Table T.4. Accuracy Classes and Load Test Tolerances for Electricity-Measuring Devices;
- (b) AC voltage rating;
- (c) Test amperes (TA);
- (d) Meter class (CL);
- (e) Watthour or rotor constant (K_h);
- (f) [MM] Register ratio (R_r or K_r) and multiplier (if greater than one) preceded by “multiply by” or “mult by” or “ K_r ”;
- (g) Frequency rating (Hz);
- (h) Number of meter stator(s) or element(s);
- (i) Watthour meter or other descriptive term;
- (j) [MM] Number of wires (W);
- (k) [MM] Form designation (FM);
- (l) [EM] Watthour test constant (K_t);
- (m) Minimum measured quantity (MMQ).

Instrument transformer-rated meters shall contain the following additional information:

- (n) Instrument transformer ratio or transformer model number;
- (o) [MM] Primary watthour constant (PK_h);
- (p) Temperature Limits, if narrower than and within $-20\text{ }^{\circ}\text{C}$ to $+50\text{ }^{\circ}\text{C}$ ($-4\text{ }^{\circ}\text{F}$ to $122\text{ }^{\circ}\text{F}$).

S.5.3. Instrument Transformer Identification. – Each instrument transformer that is non-integral with the meter shall have the following conspicuously, legibly, and indelibly marked on a permanent identification label:

- (a) Manufacturer's name, type designation, and non-repetitive serial number;
- (b) True ratio, primary versus secondary, ampere or voltage values;
- (c) Accuracy class;

- (d) Burden designation (B);
- (e) Basic lightning impulse insulation level (BIL);
- (f) Rated Frequency (HZ).

Note: If evident by the method of integration that instrument transformers are not intended to be detachable or replaceable, the required information may be located on the meter.

S.5.3.1. Polarity Marking. – A permanent mark indicating proper installation orientation is required on the instrument transformer when the accuracy of the meter is affected.

S.5.4. Abbreviations and Symbols. – The following abbreviations or symbols may appear on a meter, instrument transformer, or indicator.

- (a) FM = Form
- (b) CL = Class
- (c) V = Volts;
- (d) Hz = Hertz, Frequency or Cycles Per Second;
- (e) TA = Test Amperes;
- (f) Kh = Watthour Constant Per Rotor Revolution or Pulse;
- (g) PKh = Primary Watthour Constant;
- (h) Rr = Register Ratio;
- (i) CTR = Current Transformer Ratio;
- (j) VTR or PTR = Voltage or Potential Transformer Ratio;
- (k) MULT BY = Multiply By;
- (l) W = Wire (example: 240V 3W);
- (m) Y = WYE Power Supply;
- (n) ANSI = American National Standards Institute;
- (o) B = Burden;
- (p) BIL = Basic Lightning Impulse Insulation Factor;
- (q) Kt = [EM] Watthour Test Constant;
- (r) AC = Alternating Current (i.e. VAC);
- (s) J = Joule;
- (t) MJ = Megajoule;

- (u) Wh = Watthour;
- (v) kWh = Kilowatt-hour;
- (w) Δ = Delta Power Supply.

S.6. Printer. – When an assembly is equipped with means for printing the measured quantity, the printed information must agree with the indications on the device for the transaction and the printed values shall be clearly defined.

S.6.1. Printed Receipt. – Any delivered, printed quantity shall include a device identification number that uniquely identifies the device from all other devices within the seller’s facility, the time and date, and the name of the seller. This information may be printed by the device or pre-printed on the ticket.

S.7. Totalizers for EVSE Devices. – EVSE devices shall be equipped with a nonresettable totalizer for the quantity delivered through each separate measuring device.

S.8. Minimum Measured Quantity. – The minimum measured quantity shall satisfy the conditions of use of the measuring system as follows:

Measuring systems shall have a minimum measured quantity not exceeding 3.6 MJ or 1.0 kWh.

N. Notes

N.1. Meter Creep Test. – A meter creep test shall be conducted by applying rated voltage to the meter under test and no load applied.

N.2. Meter Starting Load. – A meter starting load test shall be conducted by applying rated voltage and 0.5-ampere load.

N.3. [MM] Test Revolutions. – Full and light load tests shall require 8 or more revolutions of the test standard and at least one revolution of the meter under test.

N.4. [EM] Meter Test Constant Output Indications. – Full and light load tests shall consist of 8 or more watthour test constant (K_t) output indications of the test standard and at least one watthour test constant (K_t) output indication of the meter under test. Test standards that read out directly in watthours shall meet the watthour equivalent of eight or more watthour test constant (K_t) output indications.

N.5. Meter and System Test Loads.

- (a) [MM] Mechanical self-contained meters shall be balanced load tested, and may be single element tested, for meter accuracy at full and light loads.
- (b) [MM] Instrument transformer rated systems shall be single element tested, and may be balanced load tested, for system accuracy at full and light loads. Meter testing shall be accomplished by applying the test load to the current transformer(s).
- (c) [EM] Instrument transformer(s) rated systems shall be single element tested, for system accuracy at full and light loads. Meter testing shall be accomplished by applying the test load to the instrument transformer(s) with the voltage circuits energized.
- (d) The reference voltage phases (A, B, or C) at the meter shall be the same phase as the load.

N.6. Test of a Meter System.

- (a) Each meter submitted for test shall be a complete system. For example: a meter body and any necessary instrument transformer(s), indicator(s), system software, etc., required to make up a complete system.
- (b) The test load applied for a full load test shall be the marked test amperes (TA) on the nameplate of the meter under test.
- (c) The test load applied for a light load test shall be conducted at not less than 10 % of the marked (TA) test amperes on the nameplate of the meter under test.
- (d) The test load applied for a full load test of a meter for a 0.5 power factor setting shall be the marked (TA) test amperes of the nameplate of the meter under test.
- (e) The test load applied for a light load test of a meter for a 0.5 power factor setting shall be conducted at not less than 20 % of the (TA) test amperes of the meter.
- (f) All tests shall be made at the rated voltage $\pm 10\%$.

N.7. Minimum Measured Quantity. – The minimum measured quantity shall be specified by the manufacturer.

N.7.1. Minimum Measured Quantity Test. – The device shall be tested for a delivery equal to the declared minimum measured quantity when the device is likely to be used to make deliveries on the order of the declared minimum measured quantity.

N.8. Repeatability Tests. – Tests for repeatability should include a minimum of three consecutive tests at the same load and be conducted under controlled conditions where variations in factors are reduced to minimize the effect on the results obtained.

T. Tolerances

T.1. Tolerances, General.

- (a) The tolerances apply equally to errors of underregistration and errors of overregistration.
- (b) The tolerances apply to all deliveries measured at any load within the rated measuring range of the device.
- (c) Where instrument transformers or other components are used, the provisions of this section shall apply to all metering components.

T.2. Meter Creep Test.

T.2.1. [EM] Meter Creep Test. – The meter indicating element shall not change by more than one least significant digit with the voltage circuit(s) energized and current circuit(s) not energized for a duration of one hour using the watt-hour test constant (K_t) output indications.

T.2.2. [MM] Meter Creep Test. – A meter rotor shall rotate no more than one complete revolution in 10 minutes with the meter voltage circuit(s) energized and the current circuit(s) not energized.

T.3. Meter Starting Load Test.

T.3.1. [EM] Meter Starting Load Test. – The watt-hour test constant (K_t) output indication shall continue to advance when a load of 0.5 amperes is applied.

T.3.2. [MM] Meter Starting Load Test. – The meter rotor shall rotate continuously when a load of 0.5 amperes is applied.

T.4. Load Test Tolerances. – The tolerances for electricity-measuring device load tests are listed in Table T.2. Accuracy Classes and Tolerances for Electricity-Measuring Devices. (Proposed tolerance values are based on ANSI C12.1 Code for Electricity Metering Section 5 Standards for In-Service Performance paragraph 5.1.2.2 Acceptable Performance for Maintenance Tolerances and on ANSI C12.20 Electricity Meters-0.2 and 0.5 Accuracy Classes Section 5 Acceptable Performance of New Types of Electricity Metering Devices and Associated Equipment paragraph 5.5.4.3 Test No. 3: Load Performance for Acceptance Tolerances.)

Table T.4. Accuracy Classes and Load Test Tolerances for Electricity-Measuring Devices			
Accuracy Class (ANSI C12.20 designation)	Application or Commodity Being Measured	Acceptance Tolerance	Maintenance Tolerance
0.2	Electricity as vehicle fuel	0.2 %	2.0 %
0.5	Electricity as vehicle fuel	0.5 %	2.0 %
All Others	Electricity as vehicle fuel	1.0 %	2.0 %
Instrument Transformers Not Integral to the Meter			
0.3 or superior	Electricity as vehicle fuel	0.3 %	2.0 % as part of system

T.4.1. Tolerance Values. – Maintenance and acceptance tolerances for electric watt-hour meters shall be as shown in Table T.4. for full and light load tests of Accuracy Class 0.2 and 0.5 meters. For all other Accuracy Class meters tolerances shall be as follows:

- (a) Maintenance tolerance shall be 2 % for full and light loads.
- (b) Acceptance tolerance shall be 1 percent for full and light loads.

T.4.2. Power Factor Tests. – Power factor tests shall be conducted at 0.5 power factor setting:

- (a) Maintenance tolerance shall be 2 % for full and light loads.
- (b) Acceptance tolerance shall be 1 % for full and light loads.

NOTE: 0.5 power factor light load tests shall be conducted at 20 % of the Test Amperes (TA).

T.5. Repeatability. – When multiple tests are conducted at the same load condition, the range of the load test results shall not exceed 25 % of the absolute value of the maintenance tolerance and the results of each test shall be within the applicable tolerance. (Indiana Code 170 IAC 4-1-8).

T.6. Instrument Transformer Accuracy Class. – An instrument transformer that is not an integral part of the meter and is used for revenue metering shall be rated 0.3 accuracy class or more accurate for the burden of a particular meter type. If a meter system requires an instrument transformer more accurate than 0.3 accuracy class, the limitations shall be stated on the meter.

T.7. Tolerance Application in Type Evaluation Examinations for Devices. – For type evaluation examinations, the acceptance tolerance values shall apply under the following conditions:

- (a) at any temperature, voltage, load, and power factor within the operating range of the device, and
- (b) regardless of the influence factors in effect at the time of the conduct of the examination, and
- (c) for all quantities greater than the minimum measured quantity.

UR. User Requirements

UR.1. Selection Requirements.

UR.1.1. Meter Class (CL). – The marked CL shall equal or exceed the total capacity in amperes of the EVSE or the thermal overload protectors of the tenant.

UR.1.2. Suitability of Equipment. – A meter shall be suitable for use on its electrical system. A three-wire two-phase load which is connected to a 120 to 208 volt network service shall be metered by a two-stator or two-element meter.

A meter shall accurately measure all loads 5 percent or greater of the electric service capacity of the tenant. Service capacity shall be determined by the master thermal overload protectors to the tenants' service or by the rated capacity of an electric cord and its connector used to provide power from the service panel to the tenant.

UR.1.3. Instrument Transformer Ratio. – The instrument transformer shall be correctly matched to the meter indicator and multiplier.

UR.1.4. Computing-Type Device; Retail EVSE Device. – A device used to charge electric vehicles shall be of the computing type and shall indicate the electrical energy, the unit price, and the total price of each delivery.

UR.1.5. Connection Line-Length. – The impedance of the connection line on a retail EVSE device shall not result in losses in excess of the tolerance. The length of the connection line:

- (a) shall not exceed 4.6 m (15 ft) unless it can be demonstrated that a longer line is essential to permit deliveries to be made to receiving vehicles;
- (b) shall be measured from its connection to the EVSE to the inlet of the vehicle connector; and
- (c) shall be measured with the connection line fully extended if it is coiled or otherwise retained or connected inside a housing.

An unnecessarily remote location of a device shall not be accepted as justification for an abnormally long connection line.

UR.2. Installation Requirements.

UR.2.1. Manufacturer's Instructions. – A device shall be installed in accordance with the manufacturer's instructions, and the installation shall be sufficiently secure and rigid to maintain this condition.

UR.2.2. Load Range. – A device shall be installed so that the current and voltage will not exceed the rated maximum values over which the meter class designation is designed to operate continuously within the specified accuracy. Means to limit current and/or voltage shall be incorporated in the installation if necessary.

UR.2.3. Regulation Conflicts and Permit Compliance. – If any provision of this section (UR.2. Installation Requirements) is less stringent than that required of a similar installation by the serving utility, the installation shall be in accordance with those requirements of the serving utility.

The installer of any new EVSE or electric watt-hour submeter service shall obtain all necessary permits and shall conform to all applicable regulatory utility commission's or commissioner's requirements.

UR.2.4. Submeter Installation Requirements.

UR.2.4.1. Certification by Serving Utility or Utilities Commission. – It is the responsibility of the owner of a submeter system to obtain written certification for each submetered service connection from the serving utility or from a person designated as qualified by either the serving utility or by the Utilities Commission (UC).

- (a) The required certification shall identify the address, space, or number, of the premise served by the submeter connection; be signed by an authorized serving utility representative or by a designee; and shall clearly state:
- (b) the installation meets all serving utility installation and accessibility requirements for similar installations served directly by the serving utility,
- (c) the installation is on a tariff schedule that qualifies for submeter use,
- (d) the billing format, rates, and charges conform to all applicable serving utility tariff rules,
- (e) the date of such determination, and
- (f) if performed by a designee, the designee's name and title, and the name and title of the serving utility company or Public Utilities Commission representative authorizing the designee to make the determination.

The certification shall be provided prior to a submeter being used for commercial purposes.

UR.2.4.2. Submeter Test Facilities. – All submeters shall be provided with the same test facilities required of a similar meter by the serving utility.

UR.2.4.3. [MM] Test Blocks. – All three-phase self-contained submeter installations shall be equipped with test blocks, which are approved by the serving utility, for safe meter testing.

UR.2.4.4. [MM] Test Switches. – Submeter installations that are equipped with current or potential transformers, or both, shall have test switches installed, which are approved by the serving utility, for safe meter testing.

UR.2.4.5. [MM] Circuit Closing Devices. – All self-contained submeter installations that cannot accept a short interruption of the electrical service, for the purpose of testing the meter, shall be equipped with a manual circuit closing device as approved by the serving utility. Automatic circuit closing devices shall not be used on any submeter installation.

UR.2.4.6. Metered Circuits (Submeter Load Service). – All electricity used by a tenant shall be taken exclusively from the load service of the tenant's meter. This service and its associated meter shall accurately measure the tenant's load and be capable of being used only at the discretion of the tenant.

UR.2.4.7. Unmetered Circuits (Submeter Line Service). – The tenant's electric circuit shall not be taken from the line terminals of the meter, meter socket, or line service. The owner of the submeter system may utilize this service.

UR.2.4.8. Dedicated Tenant Submeter Service. – A meter shall serve only the space, lot, building, room, suite, stall, slip, or premise occupied by the tenant.

UR.2.4.9. Submetered Tenant Premise Identification. – Tenant premise identification shall be clearly and permanently shown on or at the submeter, and on all separate components of a meter system, including, but not limited to, instrument transformer(s), modem(s), and transmitter(s) if equipped. Remote indications and all printed indications shall be readily identifiable and readily associated with the tenant’s premise. Printed indications shall also include time and date information.

UR.3. Use of Device.

UR.3.1. Unit Price for Retail EVSE Devices. – The unit price at which the device is set to compute shall be conspicuously displayed or posted on the face of a retail EVSE device used in direct sale.

UR.3.2. Return of Indicating and Recording Elements to Zero. – The primary indicating elements (visual) and the primary recording elements shall be returned to zero immediately before each delivery.

UR.3.3. Printed Ticket. – The total price, the total quantity of the delivery, and the price per unit shall be printed on any ticket issued by a device of the computing type and containing any one of these values.

UR.3.4. Steps After Charging. – After delivery to a customer from a retail device:

- (a) the device shall be shut-off at the end of a charge, through an automatic interlock that prevents subsequent charging until the indicating elements and recording elements, if the device is equipped and activated to record, have been returned to their zero positions; and
- (b) the vehicle connector shall not be returned to its starting position unless the zero set-back interlock is engaged or becomes engaged by the act of disconnecting from the vehicle or the act of returning the connector to the starting position.

UR.3.5. Submeter Required. – When a tenant is not directly served by the serving utility, and charges for electric energy are not included in the fixed periodic rent charges, a dedicated electric watt-hour submeter that measures only the energy used at the discretion of the tenant shall be used.

Appendix D. Definitions

The specific code to which the definition applies is shown in [brackets] at the end of the definition. Definitions for the General Code [1.10] apply to all codes in NIST Handbook 44.

A

accuracy class, instrument transformers. – A performance specification for instrument transformers which expresses the maximum deviation from the true value of a measured quantity. (Instrument Transformer Accuracy Class) Example: a 0.2 accuracy class transformer would be more accurate than a 0.3 accuracy class transformer.[3.XX]

active (real) power. – The component of electric power that performs work, typically measured in kilowatts (kW) or megawatts (MW). Also known as “real power.” The terms “active” or “real” power are used to modify the base term “power” to differentiate it from reactive and apparent power. The active power (P_{ac}) or real power measured by a meter, is the product of voltage (E) times current (I) times the cosine of the angle by which the current lags the voltage ($\cos \phi$) or power factor (pf). $P_{ac} = (E) (I) (\cos \phi)$ where ϕ is the phase angle of the lag.[3.XX]

alternating current (AC). – An electric current that reverses direction in a circuit at regular intervals.[3.XX]

ampere. – The practical unit of electric current. It is the quantity of current caused to flow by a potential difference of one volt through a resistance of one ohm. One ampere is equal to the flow of one coulomb of charge per second. One coulomb is the unit of electric charge equal in magnitude to the charge of 6.24×10^{18} electrons.[3.XX]

apparent power. – The product of the RMS current (I) and the RMS voltage (E) in a circuit.[3.XX]

audit trail. – An electronic count and/or information record of the changes to the values of the calibration or configuration parameters of a device.[1.10, 2.20, 2.21, 2.24, 3.30, 3.37, 3.39, 3.XX, 5.56(a)]
(Added 1993)

B

balanced load. – Balanced load is used to indicate equal currents in all phases and relatively equal voltages between phases and between each phase and neutral (if one exists); with approximately equal watts in each phase of the load.[3.XX]

basic lightning impulse insulation level (BIL). – A specific insulation level expressed in kilovolts of the crest value of a standard lightning impulse. (Example: BIL = 10 Kv)[3.XX]

burden (B). – The impedance of the circuit connected to the instrument transformer's secondary winding. (Example: B = 21 Ohms Max.)[3.XX]

C

calibration parameter. – Any adjustable parameter that can affect measurement or performance accuracy and, due to its nature, needs to be updated on an ongoing basis to maintain device accuracy (e.g., span adjustments, linearization factors, and coarse zero adjustments).[2.20, 2.21, 2.24, 3.30, 3.37, 3.39, 3.XX, 5.56(a)]
(Added 1993)

central location. – A laboratory or meter shop used for the testing of meters to measure in-service accuracy.[3.XX]

certified meter type. – A metering device which is tested and certified to meet the certification testing as specified in the ANSI C12 standard for a specific meter type. It shall include any optional circuit boards, devices, or modules enclosed within the meter cover as a part of this certified meter type.[3.XX]

configuration parameter. – Any adjustable or selectable parameter for a device feature that can affect the accuracy of a transaction or can significantly increase the potential for fraudulent use of the device and, due to its nature, needs to be updated only during device installation or upon replacement of a component (e.g., division value [increment], sensor range, and units of measurement).[2.20, 2.21, 2.24, 3.30, 3.37, 3.XX, 5.56(a)]
(Added 1993)

connection line impedance. – The impedance of the circuit used to convey energy sold from a fueling device to the storage of an electric vehicle.[3.XX]

creep. – A continuous apparent measurement of energy indicated by a meter with operating voltage applied and no power consumed (load terminals open circuited).[3.XX]

current. – The rate of the flow of electrical charge past any one point in a circuit. The unit of measurement is amperes or coulombs per second.[3.XX]

E

electric vehicle, plug-in. – A vehicle that employs electrical energy as a primary or secondary mode of propulsion. Plug-in electric vehicles may be all-electric vehicles (EVs) or plug-in hybrid electric vehicles (PHEVs). All-electric

vehicles are powered by an electric motor and battery at all times. All-electric vehicles may also be called battery-electric vehicles (BEVs). Plug-in hybrid electric vehicles employ both an electric motor and an internal combustion engine that consumes either conventional or alternative fuel or a fuel cell. In a parallel type hybrid-electric vehicle, either the electric motor or the engine may propel the vehicle. In a series type hybrid-electric vehicle, the engine or fuel cell generates electricity that is then used by the electric motor to propel the vehicle. EVs, BEVs, and PHEVs are capable of receiving and storing electricity via connection to an external electrical supply. Not all hybrid-electric vehicles are of the plug-in type. Hybrid-electric vehicles that do not have the capability to receive electrical energy from an external supply (HEVs) generate electrical energy onboard with the internal combustion engine, regenerative braking, or both.[3.XX]

electric vehicle supply equipment (EVSE). – The conductors, including the ungrounded, grounded, and equipment grounding conductors; the electric vehicle connectors; attachment plugs; and all other fittings, devices, power outlets, or apparatuses installed specifically for the purpose of measuring, delivering, and computing the price of electrical energy delivered to the electric vehicle.[3.XX]

electricity sold as vehicle fuel. – Electrical energy transferred to and/or stored onboard an electric vehicle primarily for the purpose of propulsion.[3.XX]

electricity meter. – A device that measures and registers the integral of an electrical quantity with respect to time.[3.XX]

electronic meter [EM]. – An electric (solid state) watt-hour meter that does not have a rotor.[3.XX]

element (stator). – A combination of a voltage-sensing unit and a current-sensing unit, which provides an output proportional to the quantities measured.[3.XX]

energy. – The integral of active power with respect to time.[3.XX]

energy flow. – The flow of energy between line and load terminals (conductors) of an electricity meter. Flow from the line to the load terminals is considered energy delivered. Energy flowing in the opposite direction (i.e., from the load to line terminals) is considered as energy received.[3.XX]

equipment, commercial. – Weights, measures, and weighing and measuring devices, instruments, elements, and systems or portion thereof, used or employed in establishing the measurement or in computing any basic charge or payment for services rendered on the basis of weight or measure. As used in this definition, measurement includes the determination of size, quantity, value, extent, area, composition (limited to meat and poultry), constituent value (for grain), or measurement of quantities, things, produce, or articles for distribution or consumption, purchased, offered, or submitted for sale, hire, or award.[1.10, 2.20, 2.21, 2.22, 2.24, 3.30, 3.31, 3.32, 3.33, 3.34, 3.35, 3.38, 3.XX, 4.40, 5.51, 5.56(a), 5.56(b), 5.57, 5.58, 5.59]

(Added 2008)

equipment level. – A designation given to different categories of EVSEs that conveys the general speed with which charging will occur.[3.XX]

event counter. – A nonresettable counter that increments once each time the mode that permits changes to sealable parameters is entered and one or more changes are made to sealable calibration or configuration parameters of a device.[2.20, 2.21, 3.30, 3.37, 3.39, 3.XX, 5.54, 5.56(a), 5.56(b), 5.57]

(Added 1993)

event logger. – A form of audit trail containing a series of records where each record contains the number from the event counter corresponding to the change to a sealable parameter, the identification of the parameter that was changed, the time and date when the parameter was changed, and the new value of the parameter.[2.20, 2.21, 3.30, 3.37, 3.39, 3.XX, 5.54, 5.56(a), 5.56(b), 5.57]

(Added 1993)

F

face. – That portion of a computing-type pump or dispenser which displays the actual computation of price per unit, delivered quantity, and total sale price. In the case of some electronic displays, this may not be an integral part of the pump or dispenser.[3.30, 3.XX]

(Added 1987)

fixed service. – Service that continuously provides the nominal power that is possible with the equipment as it is installed.[3.XX]

form designation (FM). – [MM] An alphanumeric designation denoting the circuit arrangement for which the meter is applicable, and its specific terminal arrangement. The same designation is applicable to equivalent meters for all manufacturers. (Example: FM 2S)[3.XX]

H

hertz (Hz). – Frequency or cycles per second. One cycle of an alternating current or voltage is one complete set of positive and negative values of the current or voltage.[3.XX]

I

instrument transformer. – A transformer that reproduces in its secondary circuit, in a definite and known proportion, the voltage, or current of its primary circuit, with the phase relation preserved. Sometimes these devices may be referred to as VTs (Voltage Transformers) or CTs (Current Transformers).[3.XX]

instrument transformer-rated meter. – A metering system with terminals arranged for connection to the secondary windings of external instrument transformers.[3.XX]

instrument transformer ratio. – The stated ratio of the primary circuit current or voltage compared to the secondary circuit current or voltage. (Example: CTR = 200 : 0.1)[3.XX]

J

megajoule (MJ). – An SI unit of energy equal to 1 000 000 joules.[3.XX]

K

kilowatt (kW). – A unit of power equal to 1 000 watts.[3.XX]

kilowatt-hour (kWh). – A unit of energy equal to 1 000 watthours.[3.XX]

L

line service. – The service terminals or conductors connecting the meter to the power source.[3.XX]

load service. – The service terminals or conductors connecting the meter to the electrical load (e.g., vehicle, tenant, etc.)[3.XX]

load, full. – A test condition with rated voltage, current at 100 % of test amps level, and power factor of 1.0.[3.XX]

load, light. – A test condition with rated voltage, current at 10 % of test amps level, and power factor of 1.0.[3.XX].

M

master meter, electric. – An electric watthour meter owned, maintained, and used for commercial billing purposes by the serving utility. All the electric energy served to a submetered service system is recorded by the master meter.[3.XX]

mechanical meter [MM]. – A watthour meter with a rotor.[3.XX]

meter class designation (CL). – The manufacturer’s designated maximum amperes a meter can measure continuously without damage or exceeding limits of accuracy. (Example: CL 200)[3.XX]

meter, electricity. – An electric watthour meter.[3.XX]

metrological components. – Elements or features of a measurement device or system that perform the measurement process or that may affect the final quantity determination or resulting price determinations. This includes accessories that can affect the validity of transactions based upon the measurement process. The measurement process includes determination of quantities; the transmission, processing, storage, or other corrections or adjustments of measurement data or values; and the indication or recording of measurement values or other derived values such as price or worth or charges.[3.XX]

N

nominal power. – Refers to the “intended” or “named” or “stated” as opposed to “actual” rate of transfer of electrical energy (i.e., power).[3.XX]

nonresettable totalizer. – An element interfaced with the measuring or weighing element that indicates the cumulative registration of the measured quantity with no means to return to zero.[3.30, 3.37, 3.39, 3.XX]

O

ohm. – The practical unit of electric resistance that allows one ampere of current to flow when the impressed potential is one volt.[3.XX]

P

percent registration. – Percent registration is calculated as follows:

$$\text{Percent Registration} = \frac{\text{Wh measured by METER}}{\text{Wh measured by STANDARD}} \times 100 [3.XX]$$

percent error. – Percent Error = Percent Registration – 100. A meter is said to be “slow” that has percent registration below 100 % and negative percent error.[3.XX].

point-of-sale system. – An assembly of elements including a weighing or measuring element, an indicating element, and a recording element (and may also be equipped with a “scanner”) used to complete a direct sales transaction.[2.20, 3.30, 3.32, 3.37, 3.39, 3.XX]

(Added 1986) (Amended 1997)

power factor. – The ratio of the active power to the apparent power in an AC circuit. The power factor is a number between 0 and 1 that is equal to 1 when the voltage and current are in phase (load is entirely resistive).[3.XX]

primary watthour constant (PK_h) [MM]. – The meter watthour constant per revolution or pulse (K_h) multiplied by the product of the current and/or voltage transformer ratio(s):

$PK_h = K_h$ (Current Transformer Ratio X Voltage Transformer Ratio).[3.XX]

R

reactive power. – For sinusoidal quantities in a two-wire circuit, reactive power is the product of the voltage, the current, and the sine of the phase angle between them, using the current as the reference.[3.XX]

register ratio (R_r) [MM]. – The number of revolutions of the gear meshing with the worm or pinion on the rotor shaft per complete rotation of the fastest (most sensitive) wheel or dial pointer.[3.XX]

remote configuration capability. – The ability to adjust a weighing or measuring device or change its sealable parameters from or through some other device that is not itself necessary to the operation of the weighing or measuring device or is not a permanent part of that device.[2.20, 2.21, 2.24, 3.30, 3.37, 3.39, 3.XX, 5.56(a)]

(Added 1993)

retail device. – A measuring device primarily used to measure product for the purpose of sale to the end user.[3.30, 3.32, 3.37, 3.39, 3.XX]

(Amended 1987 and 2004)

revolution equivalent. – The number of watthours represented by one increment (pulse period) of serial data.[3.XX]

root mean square (RMS). – The mathematical convention used to describe the average quantity of a property (such as current) that is varying as a sine wave.[3.XX]

S

serving utility. – The utility distribution company that owns the master meter and sells electric energy to the owner of a submeter system.[3.XX]

side. – That portion of a pump or dispenser which faces the consumer during the normal delivery of product.[3.30, 3.XX]

(Added 1987)

starting load. – The minimum load above which the device will indicate energy flow continuously.[3.XX]

stator [MM]. – The unit which provides the driving torque in a watthour meter. It contains a voltage coil, one or more current coils, and the necessary steel to provide the required magnetic paths.[3.XX]

submeter. – A meter furnished, owned, installed, and maintained by the customer who is served through a utility owned master meter.[3.XX]

T

tenant. – The person or persons served electric energy from a submetered service system.[3.XX]

test accuracy – in-service. – The device accuracy determined by a test made during the period that the meter is in service. It may be made on the customer's premises without removing the meter from its mounting, or by removing the meter for testing either on the premises or in a laboratory or meter shop.[3.XX]

test amperes (TA). – The full load current (amperage) specified by the device manufacturer for testing and calibration adjustment. (Example: TA 30)[3.XX]

test block. – Device that facilitates safe meter testing by disconnecting the meter from the circuit without interrupting the service to the tenant.[3.XX]

thermal overload protector. – A circuit breaker or fuse that automatically limits the maximum current in a circuit.[3.XX]

U

unit price. – The price at which the product is being sold and expressed in whole units of measurement.[1.10, 3.30, 3.XX]

(Added 1992)

V

variable service. – Service that may be controlled resulting in periods of reduced, and/or interrupted transfer of electrical energy.[3.XX]

volt. – The practical unit of electromotive force. One volt will cause one ampere to flow when impressed across a resistance of one ohm.[3.XX]

voltage transformer. – A device that provides a secondary voltage that is a precise fraction of the primary voltage.[3.XX]

W

watt. – The practical unit of electric power. In an alternating-current circuit (AC), the power in watts is volts times amperes multiplied by the circuit power factor.[3.XX]

watthour (Wh). – The practical unit of electric energy, which is expended in one hour when the average power consumed during the hour is one watt.[3.XX]

watthour meter. – An electricity metering system comprised of components functioning together that measures and registers the integral, with respect to time, of the active or real power of the circuit in which it is connected. This power integral is the energy delivered to the circuit during the interval over which the integration extends. The unit in which this integral is measured is usually the kilowatt-hour.[3.XX].

watthour meter – field standard. – A portable meter that is traceable to NIST and is used as a standard meter to test meters in commercial applications. This meter is also known as a portable standard or working standard.[3.XX]

watthour meter – self-contained. – A meter in which the terminals are arranged for connection to the circuit being measured without using external instrument transformers.[3.XX]

watthour meter constant (K_h). – The expression of the relationship between the energy applied to the meter and one rotor revolution, or output indication, expressed as watthours per revolution or, watthours per output indication.[3.XX]

watthour meter – test constant (K_t) [EM]. – The expression of the relationship between the energy applied to the meter system and corresponding occurrence of one test output indication expressed as watthours per test output indication.[3.XX]

Report of the Professional Development Committee (PDC)

Dale Saunders, Chair
Virginia

400 INTRODUCTION

This is the report of the Professional Development Committee (PDC) (hereinafter referred to as the “Committee”) for the 99th Annual Meeting of the National Conference on Weights and Measures (NCWM). This report is based on the Interim Report offered in the NCWM Publication 16, “Committee Reports,” testimony at public hearings, comments received from the regional weights and measures associations and other parties, the NCWM 2014 Online Position Forum, the addendum sheets issued at the Annual Meeting, and actions taken by the membership at the voting session of the Annual Meeting. The Informational items shown below were adopted as presented when this report was approved.

Table A identifies the agenda and appendix items by reference key, title of item, page number and the appendices by appendix designations. The acronyms for organizations and technical terms used throughout the agenda are identified in Table B. The first three digits of an item’s reference key are assigned from the Subject Series List. The status of each item contained in the report is designated as one of the following: **(D) Developing Item:** the Committee determined the item has merit; however, the item was returned to the submitter or other designated party for further development before any action can be taken at the national level; **(I) Informational Item:** the item is under consideration by the Committee but not proposed for Voting; **(V) Voting Item:** the Committee is making recommendations requiring a vote by the active members of NCWM; **(W) Withdrawn Item:** the item has been removed from consideration by the Committee.

Table B provides a summary of the results of the voting on the Committee’s items and the report in its entirety. Some Voting Items are considered individually, others may be grouped in a consent calendar. Consent calendar items are Voting Items that the Committee has assembled as a single Voting Item during their deliberation after the Open Hearings on the assumption that the items are without opposition and will not require discussion. The Voting Items that have been grouped into consent calendar items will be listed on the addendum sheets. Prior to adoption of the consent calendar, the Committee entertains any requests from the floor to remove specific items from the consent calendar to be discussed and voted upon individually.

Proposed revisions to the handbook(s) are shown as follows: 1) deleted language is indicated with a **bold face font using strikeouts** (e.g., ~~this report~~), and 2) proposed new language is indicated with an **underscored bold faced font** (e.g., new items). When used in this report, the term “weight” means “mass.”

Note: The policy is to use metric units of measurement in all of its publications; however, recommendations received by NCWM technical committees and regional weights and measures associations have been printed in this publication as submitted. Therefore, the report may contain references to inch-pound units.

Subject Series List

Introduction	400 Series
Education.....	410 Series
Program Management.....	420 Series

**Table A
Table of Contents**

Reference Key	Title of Item	Page PDC
400	INTRODUCTION.....	1
410	EDUCATION	3
410-1	I Professional Certification Program.....	3
410-2	I Training	7
410-3	I Instructor Improvement	8
410-4	I Recommended Topics for Conference Training.....	8
420	PROGRAM MANAGEMENT	10
420-1	I Safety Awareness	10
420-2	I PDC Publication	12

Appendices

A	Professional Certification Program Curriculum Work Plan.....	A1
B	History of Professional Certification Program.....	B1
C	History of Instructor Improvement.....	C1
D	Training Manual.....	D1

**Table B
Voting Results**

<i>Reference Key Number</i>	<i>House of State Representatives</i>		<i>House of Delegates</i>		<i>Results</i>
	<i>Yeas</i>	<i>Nays</i>	<i>Yeas</i>	<i>Nays</i>	
To accept the Report	Voice Vote				Adopted

Table C
Glossary of Acronyms and Terms

Acronym	Term	Acronym	Term
ADDIE	Analysis, Design, Development, Implementation, and Evaluation	NEWMA	Northeastern Weights and Measures Association
ANSI	American National Standards Institute	NIST	National Institute of Standards and Technology
BOK	Body of Knowledge	OWM	Office of Weights and Measures
CWMA	Central Weights and Measures Association	PDC	Professional Development Committee
ISO	International Standardization Organization	RSA	Registered Service Agents
ICE	Institute for Credentialing Excellence	SME	Subject Matter Expert
NCWM	National Conference on Weights and Measures	SWMA	Southern Weights and Measures Association
		WWMA	Western Weights and Measures Association

DETAILS OF ALL ITEMS
(In order by Reference Key)

410 EDUCATION

410-1 I Professional Certification Program

Professional certifications are offered in many industries as a means of demonstrating competence in a particular field of expertise. Certification may be a means of qualifying an individual for employment or higher pay grade within a profession. The NCWM Professional Certification Program provides confidence that an individual has a strong understanding of U.S weights and measures standards as adopted by NCWM and published in NIST Handbooks, 44, 130, and 133.

Professional certification is available to NCWM members and non-members in the private sector and in government positions. Please note that the person taking the test must be an NCWM member in order to receive the exams for free.

To date, the Committee has developed exams for retail motor fuel dispensers (RMFD), basic package checking, and small capacity scales Class III. Additional examinations will be offered in the following order:

- Vehicle tank meters
- Medium capacity scales

- Large capacity scales
- LPG
- Price Verification

Based on a 2011 survey, the existing priorities for the next exams include taximeters, mass flow meters, timing devices, and packaging and labeling requirements. The Committee continues to solicit feedback on priorities for future exams. Please contact the Committee Chair through NCWM Headquarters. A listing of modules and other potential exam subjects is provided in the PDC Curriculum Work Plan (PDC Appendix A).

At the 2014 NCWM Interim meeting, the Committee heard the following comments on this item:

- Ms. Julie Quinn, Minnesota Weights and Measures Director, made the comment that she had her light duty inspectors take the basic package checking exam, and even though they were trained to do volumetric testing, they did not pass the exam because they do not apply the principles in the field very often. Practical experience and not just book learning is necessary to pass the test. Ms. Carol Hockert, NIST, OWM, agreed and said that NIST, OWM's basic package checking course covers only checking packages labeled by weight and the intermediate class is on packages labeled by volume. Mr. Ross Andersen indicated that he and the Committee will look at the issue and see if something needs to change with regard to this package checking test. The committee plans to survey the states to see if there is agreement that testing packages labeled by volume is really an intermediate, and not a basic, skill.
- In response to a question on how to find current EPOs from NIST Handbook 112, Ms. Hockert said that the EPOs were in the process of being updated but would be back on the NIST, OWM website this spring. The Committee suggests that anyone interested in obtaining the most current EPOs should contact NIST OWM.
- Mr. Jerry Buendel, Washington Program Manager, asked that the Committee not lower the bar on the exams but keep them at a high level. Mr. Buendel expressed the need to have the best questions possible to maintain the integrity and the quality of the certification. He also requested exam takers get feedback when they failed an exam so they can improve on the areas that need to be strengthened. Mr. Dale Saunders, PDC Committee Chair, responded on behalf of the Committee that providing feedback to the exam takers could jeopardize the ability to get accreditation for the Certification Program. Ms. Quinn offered the opinion that most people know which questions they are unsure of or struggled with.
- Mr. Andersen commented that as Certification Coordinator, his job is to regularly evaluate the exam questions to make sure the exams are balanced, relative to the Module and chosen competency level, to check whether individual questions are mechanically flawed or don't fit the learning objective in the module, and to check whether the competency level of the learning objectives are correct. While high failure rates may indicate problems with the exam questions, it may also indicate that candidates are not well prepared for the type of exam they are taking.
- Mr. Kurt Floren, Los Angeles County Agriculture Commissioner, expressed his appreciation to Mr. Andersen and the subject matter experts who do not receive compensation for the time and the effort they are putting into this process. Mr. Andersen clarified that recently retired weights and measures individuals will be compensated somewhat to help write some of the questions for upcoming exams, as explained in the NCWM Board of Directors' report, Item 110-2.

Status of Current tests

Current tests – RMFD, Small Capacity Scales Class III, and Basic Package Checking

The Committee reported that exam statistics show steady improvement over time, indicating that much of the problem with passing the tests has to do with a need to acclimate to the learning objectives in the modules and to the experience of on-line testing.

Retail Motor Fuel Devices	FY 2011	FY 2012	FY 2013	Total
# of Registrants	76	107	29	212
# of Certificates Issued	45	83	18	146
% certificates per registrants	59 %	78 %	62 %	69 %

Small Capacity Scales Class III	FY 2011	FY 2012	FY 2013	Total
# of Registrants	-	17	51	68
# of Certificates Issued	-	6	18	24
% certificates per registrants	-	35 %	35 %	35 %

Package Checking Basic	FY 2011	FY 2012	FY 2013	Total
# of Registrants	-	15	27	42
# of Certificates Issued	-	5	11	16
% certificates per registrants	-	33%	41%	38%

The vehicle tank meters (VTM) exam is in development now, as well as the medium and large capacity scale exams. The SMEs are currently writing the questions. The Certification Coordinator is currently seeking SMEs for the LPG liquid measuring exam. A notice about SMEs for the price verification exam will come out later this spring. The Committee thanks those who have already volunteered to be SMEs.

The Committee wishes to acknowledge the SMEs currently working on the VTM and medium and large capacity scale exams:

Vehicle Tank Meters	Medium Capacity Scales Large Capacity Scales
Conrad Brown, ME	Mark Buccelli, MN, Ret
Charles Carroll, MA	Jim Daggon, Rice lake Weighing
Gabe Frezzo, Industry, PA	Dennis Fox, Central Illinois Scale
Lewis Hutfles, KS	Nathan Gardner, OR
Paul Jordan, CA	Joe Grell, Rice Lake Weighing
Antony Joseph, NY	Roger Macey, CA, Ret
John Kirk, VA	Matthew Maiten, Santa Barbara, CA
Gary Kneissel, MN	Mike Mann, WA
Mike Mann, WA	Albie Michelson, WY, Ret
Albie Michelson, WY, Ret	John Pasko, WI
Ron Pierce, PA	Kevin Pfeiffer, VA
Gary Sassaman, Liquid Meas & Controls, PA	Doug Rudy, PA

Vehicle Tank Meters	Medium Capacity Scales Large Capacity Scales
Scott Simmons, CO	Mike Smith, NY
Mike Smith, NY	Richard Suiter, NE, NIST, Ret
Michael Swimm, ME	Courtney Ward, Quality Scales
Otto Warnlof, MN/NIST, Ret	Otto Warnlof, MN, NIST, Ret
Jared Williams, WI	
Ray Woolfolk, AK	
Jane Zulkiewicz, Barnstable, MA	

The Committee also wants to assure members that SMEs will not compromise their ability to be trainers. SMEs will not be allowed to have access to more than 25 % of the exam questions.

Mr. Don Onwiler made a comment that this restriction on access to the test questions is an important part of maintaining the integrity of the exam process as the certification program moves toward formal accreditation. Eventually, exam questions may need to be copyrighted. SMEs should note that they should modify exam questions before submitting them to the Certification Coordinator if they wish to continue to use those questions in their own exams.

Regional Associations Comments:

WWMA supports the continued development of the Certification and Proficiency Testing Program. The membership recognizes the value of the test in improving skills, enhancing credibility of both weights and measures officials and registered service agents. The Committee commends the efforts made by the volunteer subject matter experts, contract staff, and NCWM leadership involved in this initiative.

NEWMA members recognize the importance of the certification exams in demonstrating knowledge and skills in utilizing the handbook, and enhancing the credibility of both weights and measures officials and registered service agents. Members continue to appeal for an overview of their certification exam results so they can determine where skills need improvement. Some individuals are still experiencing problems with timeouts and citation issues. A suggestion was made to again review the amount of time that was allowed to complete each section of the exam. NEWMA is thankful to the volunteer efforts of the subject matter experts, the Certification Coordinator, and others involved in the development and implementation of the certification examinations.

At the 2014 CWMA Annual Meeting, an industry representative asked why so few people were taking the certification tests. Minnesota indicated that their inspectors would only be taking the test every five years, unless there was job turnover. Ohio indicated that labor contracts needed to be renegotiated before they could require their inspectors to take the tests. Mr. John Gaccione said that the Northeast states also were bound by labor contracts that made requiring the tests difficult. They currently require civil service exams. Iowa indicated some states might want to use the tests but might lack the staff and time to develop a program. The room was polled on how the tests were being used:

- Two states (Minnesota and Missouri) require their investigators to take and pass the certification tests.
- Two states (Iowa and Ohio) are working on requiring that their registered service agents take the test.

Ohio is offering five continuing education credits or each test taken and passed by an inspector.

410-2 I Training

The purpose of this item is to share best practices and approaches to training in response to the broad training needs of weights and measures jurisdictions, and to serve as a link to various training materials on the web. Eventually, Item 410-2 will become the home for the training material program currently under development by the NCWM Board of Directors.

The Committee reported that the Board of Directors is assembling a new work group to be headed by Michael Cleary, former Director of the California Division of Measurement Standards. The function of the work group will be to develop guidance on the scope of training for weights and measures officials, and will report to the PDC. Anyone interested in serving on this working group should contact the NCWM Board of Directors. Appendix D has been added which includes; A Competency- Based Evaluation Scale, an Interpersonal Skills for Field Training Inspectors document, Standardize Evaluation Guidelines, a Routine Observation Report Form, and a Training Program for Department of Commerce Weights and Measures Investigator I Training. Please note that the newly added items in Appendix D are a work in progress and may change somewhat in the future.

- Mike Cleary gave an overview of the objectives and progress of the Training Manual Task Group. Members include:
 - Mike Cleary, Chair, California (Retired)
 - Craig Harris, Ohio
 - Josh Nelson, Oregon
 - Debbie Radar, Arizona
 - Julie Quinn, Minnesot
 - Scott Simmons, Colorado
 - Agatha Shields, Ohio
 - Paul Jordan, California
 - Greg Gholston, Missouri
 - Nathan Gardner, Oregon
- The objectives of this group are to:
 - Gather subject matter experts.
 - Identify the core competencies necessary to be a successful weights and measures inspector.
 - Develop a comprehensive field training guide comprised of core competencies linked to the handbooks.
 - Develop a competency based evaluation process.
 - Develop selection criteria for Field Training Inspectors (FTI) and those who will manage the field training and their relationship to management.
 - Develop a Routine Observation Form (ROF) that lists basic employee skills during the training period.
 - Develop a detailed rating system for the ROF.
 - Develop a rating system for the core competencies checklist.

To date, the task group has developed the ROF, a detailed rating for the ROF, a rating methodology (a competency based evaluation scale), and criteria guide for selecting field training inspectors.

- Ms. Hockert stated that there have been two Train the Trainer classes, one in April 2013 and another in December 2013. A subsequent Train the Trainer course for those who took the first class will be offered in April 2014. The goal is to develop a long term training program to build a pool of regional trainers for both their states and for their regions. She also said that NIST OWM will conduct a half-day training event at all the regional meetings for managers to evaluate the success of the training.
- Mr. Andersen suggested that trainers should be encouraged to take the existing NCWM certification exams to become familiar with the types of questions asked. He also suggested trainers incorporate the NCWM modules in all of their training plans.

Regional Associations Comments:

The WWMA supports the development of a field training program for weights and measures officials. The training program will be a valuable resource in the technical training, professional development, and evaluation of weights and measures officials. The program, as envisioned, will allow officials to quickly tailor training programs to the individual program's needs, provide an outline for each segment of the training, and supply tools for tracking the trainee's progress and proficiency. The members urge the NCWM PDC and the Board to support this project and closely track its progress.

NEWMA believes that training and development is an important component to any weights and measures program.

410-3 I Instructor Improvement

Report Cleanup:

Interim 2013 Meeting: The Committee agreed to move the historical data in the current item to Appendix C with the intention of moving it into the Committee archives at the 2014 Interim. Moving forward, historical information will be archived, and this item will contain only current action items.

Current Items:

NIST, OWM provided two Train the Trainer courses as a way to increase the number of trainers available to teach OWM courses. Additional classes will be offered in the future. The training is free, and OWM asks for a minimum commitment from each participant of leading one to two training courses with a NIST, OWM trainer in the subsequent year. Expenses involved with teaching the course(s) are covered by OWM. Thirty-seven individuals have been trained thus far.

Regional Associations Comments:

The WWMA expresses its gratitude to NIST, OWM and commends them for offering this valuable course. The training is designed to improve the quality of weights and measures regulatory activities, enhance the skills of the staff, and promote uniformity. The trained trainers are a beneficial resource, which is available to all jurisdictions. This initiative is an excellent example of the innovative partnership between NIST and NCWM.

NEWMA 2014 Annual Meeting: A comment was made that having regional trainers that are well trained in adult learning, as well as in technical material, will be beneficial in helping individuals to retain information when training is given. NIST, OWM is doing a great job!

CWMA 2014 Annual Meeting: NIST, OWM reported that 37 student-trainers from 30 states had participated in the Regional Trainer Program so far, and a few were almost ready to start training others on their own. Ohio reported that their trainers were much more effective because of this training. Minnesota asked if similar training could be developed for staff who trains new hires one-on-one in the field. NIST, OWM prefers to concentrate its efforts on areas where there are gaps; so they will not be organizing that kind of training. They recommended the Bob Pike Group and the Training Clinic (both in Minnesota) for developing field trainers.

410-4 I Recommended Topics for Conference Training

The Board of Directors has charged the Committee with recommending appropriate topics for the technical sessions at future Annual Meetings. The Board of Directors asked the PDC to review and prioritize possible presentations and submit those to NCWM Chairman. The Chairman will coordinate with NCWM staff to secure presenters and schedule the sessions.

The Committee acknowledged the continued interest for a presentation on "Making Sense of Electronic Receipts" and is seeking assistance in identifying a suitable presenter on the topic. A comment was heard from the floor that "Price Posting on Retail Motor Fuel Devices" should be added to the list so the new changes can be explained.

The Committee would like to recommend that the regional associations and NCWM consider offering training on:

- Making Sense of Electronic Receipts;
- Training the Trainer in Adult Learning Techniques;
- Ethics for Weights & Measures Officials; and
- Data Privacy Issues Faced by Weights & Measures Officials.

The PDC continues to carry the following list and recommends these topics for possible training seminars, roundtables, or symposia for presentation at future NCWM meetings:

- Guidelines for Supplemental Declarations (recommended by PALS);
- Alternative Fuels Issues (Fuel Volatility, Ethanol Blending, and Biodiesel Blend);
- Ergonomics (including Proper Lifting Techniques, Back and Stress Techniques, and Office Ergonomics);
- Public Relations (specifically dealing with aggressive/angry people) (recommended by the SWMA);
- General Safety Issues (recommended by the WWMA);
- Defensive Driving (recommended by the WWMA);
- Administrative Civil Penalty Process (recommended by the WWMA);
- Price Verification (recommended by the WWMA);
- Customer Service (recommended by the WWMA);
- Moisture Loss;
- Documenting Investigations for Court Proceedings;
- Honing Presentation Skills;
- Emerging Issues;
- Implementing New RMFD Price Posting and Computing Capability Revisions (recommended by the WWMA);
- Fundamentals of the National Type Evaluation Program (recommended by the WWMA);
- Electric Vehicles: Commercial Devices, Method of Sale, Advertising and Labeling (recommended by the WWMA);
- Understanding the International Weights and Measures Standards Development System (recommended by the WWMA); and
- Crane Operation and Safety (recommended by the NEWMA).

The following is a list of recent presentations. Presentations since 2010 are available at www.ncwm.net/meetings/annual/archive:

- Taximeter Technology Advancements (Mr. Matt Daus, International Association of Transportation Regulators, 2013);
- Advanced Vehicles and Fuel Quality (Mr. John M Cabaniss, Jr., Association of Global Automakers, 2013);
- Economic Justification and Demonstrating Value of Weights and Measures (Mr. Tim Chesser, Arkansas Bureau of Standards, 2012);
- Conducting Effective Marketplace Surveys and Investigations (Ms. Judy Cardin, Wisconsin Weights and Measures, 2012);
- Public Relations and Customer Service as Regulators (Mr. Doug Deiman, Alaska Division of Measurement Standards/CVE, 2012);
- An Overview of Unit Pricing in the United States (Mr. David Sefcik, NIST, OWM, 2011);
- Grocery Unit Pricing in Australia (Mr. Ian Jarratt, Queensland Consumers Association, 2011);
- Grocery Unit Pricing in Canada (Mr. Ian Jarratt, Queensland Consumers Association, 2011);
- The U.S. Hydrogen Measuring System: The Turning Point? (Ms. Kristin Macey, California Division of Measurement Standards, 2011);
- Corrosion in Ultra Low Sulfur Diesel Underground Storage Systems (Mr. Prentiss Searles and Ms. Lorri Grainawi, American Petroleum Institute, 2010);
- Risk-Based Inspection Schemes (Mr. Henry Oppermann, Weights and Measures Consulting, LLC, 2010);
- Diesel Exhaust Fluid (DEF) (Mr. Gordon Johnson, Gilbarco, Inc., and Mr. Randy Moses, Wayne, 2009);
- Fuel Volatility and Ethanol Blending (Mr. Jim McGetrick, BP Products, 2009);
- Investigative Techniques (Mr. Michael Cleary, Retired, 2009);

- Automatic Temperature Compensation (ATC) Field Test Procedures;
- Elements of an Effective Safety and Health Program (Mr. Dan Whipple, Organization???, 2008);
- Analyzing Temperature Compensation Data (Mr. Henry Oppermann, NIST, OWM, and Mr. Steven Malone, Nebraska Division of Weights and Measures, 2007);
- The Great Temperature Compensation Debate (Mr. Ross Andersen, New York Bureau of Weights and Measures, 2007);
- NIST Handbook 44, Scale Code Tare Changes (Mr. Steve Cook, NIST OWM, XXXX DATE).

Regional Associations Comments:

The WWMA recommends adding the following topic to the Conference training list: “Outreach and Promotional Materials.” For example, outreach to legislative bodies, the general public, civic groups, industry, and news/social media.

The CWMA recommends training on the 2012 changes in NIST Handbook 44 related to pre-delivery and post-delivery discounts on retail motor fuel dispensers.

420 PROGRAM MANAGEMENT

420-1 I Safety Awareness

- Mr. Brett Gurney, Utah Weights & Measures Program Manager, notified the Committee that he is now the representative for the Western Weights and Measures Association and will be submitting his article soon.
- Ms. Julie Quinn reminded the Committee that Regional Safety Liaisons should contact the states within their regions to obtain information about the general types of safety problems experienced. Jurisdictions are encouraged to send their safety reports and issues to their Regional Safety Liaison, who in turn will forward them to the PDC.

Below is a list of the Regional Safety Liaisons. Regional Associations should keep the committee updated on current liaison assignments.

Central Weights and Measures Association (CWMA):

Ms. Julie Quinn, Minnesota Weights and Measures Division

Northeastern Weights and Measures Association (NEWMA):

Mr. Michael Sikula, New York Bureau of Weights and Measures

Southern Weights and Measures Association (SWMA):

Mr. Matthew Curran, Florida Department of Agriculture and Consumer Services

Western Weights and Measures Association (WWMA):

Mr. Brett Gurney, Utah Department of Agriculture and Food

The Committee will continue asking the regions to prepare articles for the NCWM Newsletter and has revised the schedule as follows for future issues. The Committee plans to notify the Regional Safety Liaisons as their assignment date approaches.

Region	Issue	Article Deadline	Published
WWMA	2014, Issue 1	18-Jan-14	February
CWMA	2014, Issue 2	16-Apr-14	May
NEWMA	2014, Issue 3	17-Jul-14	September
SWMA	2015, Issue 1	24-Jan-15	February

Email all articles to NCWM headquarters at info@ncwm.net.

The Committee would like to thank those persons who submitted safety related articles to NCWM Newsletter. In particular, the Committee recognizes the contributors for the 2012 NCWM Newsletters.

- Behavior Based Safety, 2013 Issue 1 (Julie Quinn, Minnesota)
- New Requirements for Right-to-Know Training, 2013 Issue 2 (Mike Sikula, New York)

The Committee asks for suggestions for safety articles that people would like to see in future newsletters and/or safety issues that need to be addressed immediately. The PDC reminds regional associations to check the submission deadlines for their upcoming article assignments. Send completed articles to NCWM headquarters by the submission deadline.

Regional Associations Comments:

The WWMA reported that Mr. Gurney, Utah Department of Agriculture and Food will replace Mr. Deiman as WWMA regional safety liaison. The WWMA thanks Mr. Deiman for his service and leadership.

CWMA 2014 Annual Meeting: Minnesota echoed Mr. Bob Murnane's comment from the NCWM Interim Meeting, that this item was one of the most important but least developed items on the agenda, and urged volunteers to join the Committee specifically to work on developing it. A discussion of common safety issues ensued. The following safety concerns and incidents were reported:

- Electrical Hazards
 - Grounding problem in an electric pump on a prover caused a fire and destruction of a return hose
 - Electrical grounding problem at a dispenser caused the death of a young girl at a marine fueling station when she grabbed the dock
- Physical hazards from the general public
 - Drive by shootings at gas stations when inspectors were present
 - Bank robbery in a grocery store while the inspector was checking cash register scales
 - Inspectors being struck, or nearly struck, by vehicles while they worked
 - Inspectors not knowing electric vehicles were in their work area because the vehicles make no sound
 - People smoking in gas stations
 - People on cell phones, particularly at gas stations
- Physical hazards from business owners and clients
 - Inspector being jumped from behind by an angry station owner
 - Inspector being locked in an office by an angry owner
 - Grenade found in the cabinet of a RMFD at a location where the owner was hostile to the inspector
- Snakes in RMFD cabinets
- Confined spaces – scale pits

OSHA requiring a respiratory program when inspectors have to work at sites which require them to use respirators.

420-2 I PDC Publication

No comments were received at the 2014 NCWM Interim Meeting. The PDC will work with NCWM staff to revamp the NCWM webpage to improve accessibility to PDC publications.

Regional Associations Comments:

The WWMA recognizes the value of the improved website and commends NCWM for its work.

Mr. Dale Saunders, Virginia | Committee Chair
Ms. Cheryl Ayer, New Hampshire | Member
Ms. Kristin Macey, California | Member
Mr. Stacy Carlsen, Marin County, California | Member
Ms. Julie Quinn, Minnesota | Member
Mr. Richard Shipman, Rice Lake Weighing Systems | Associate Membership Representative

Mr. Ross Andersen | Certification Coordinator

Professional Development Committee

Appendix A

Professional Certification Program Curriculum Work Plan

Revised January 2014

Module/Subject

Level 1/Level 2/Level 3

1. Fundamentals of Weights and Measures

- 1.1. Introduction to Weights and Measures Programs
- 1.2. Weights and Measures Laws and Regulations
- 1.3. Field Standards and Test Equipment
- 1.4. State Program Scope and Overview
- 1.5. Enforcement Powers

2. Weights and Measures Administration

- 2.1. Fundamentals of Weights and Measures Administration (Commercial System, Powers and Duties, etc.)
- 2.2. Administration Functions (Personnel, Management, Budget, Safety, etc.)
- 2.3. Legislation and Regulations (Legal Considerations, Interaction with Legislature, Stakeholders, Industry, etc.)
- 2.4. Regulatory Control (Device Inspection, Commodities, Complaints)
- 2.5. Laboratory Metrology Administration (Purpose of Laboratory, Responsibilities of Metrologist, NIST Expectations for Recognition of Laboratory, Quality System, Training Requirements, etc.)
- 2.6. Public Relations and Communications (Publicity, Public Relations, Communications)

3. Laboratory Metrology

- 3.1. NIST Fundamentals of Metrology
- 3.2. NIST Mass Metrology Seminar
- 3.3. NIST Volume Metrology Seminar
- 3.4. NIST Length Metrology Seminar
- 3.5. NIST Advanced Mass

4. Device Control Program

- 4.1. Safety Considerations
- 4.2. *NIST Handbook 44* – Introduction to Device Control
- 4.3. Weighing Systems, General
 - 4.3.1. Static Electronic Weighing Systems, General
 - 4.3.2. Static Mechanical and Hybrid Weighing Systems, General
 - 4.3.3. Dynamic Weighing Systems, General
 - 4.3.4. Precision Weighing Systems Class I and II
 - 4.3.5. Small Capacity Weighing Systems Class III
 - 4.3.6. Medium Capacity Weighing Systems Class III
 - 4.3.7. Large Capacity Class III and III L Weighing Systems (Vehicle and Livestock)
 - 4.3.8. Large Capacity Class III and III L Weighing Systems - Advanced
 - 4.3.9. Railroad Track Weighing Systems
 - 4.3.10. In-Motion Railroad Track Weighing Systems
 - 4.3.11. Hopper Weighing Systems
 - 4.3.12. Automatic Bulk Weighing Systems
 - 4.3.13. Automatic Weighing Systems
 - 4.3.14. Belt Conveyor Weighing Systems
 - 4.3.15. In-Motion Monorail Weighing Systems
 - 4.3.16. Point-of-Sale Weighing Systems
 - 4.3.17. Other Specialty Weighing Systems
- 4.4. Dynamic Measuring Systems – General
 - 4.4.1. Retail Motor Fuel Dispensers

- 4.4.2. Loading Rack and Other Stationary Metering Systems
- 4.4.3. Loading Rack and Other Stationary Metering Systems – Advanced
- 4.4.4. Vehicle-Tank Meter Systems
- 4.4.5. Vehicle-Tank Meter Systems – Advanced
- 4.4.6. Milk Metering Systems
- 4.4.7. Water Meters
- 4.4.8. Liquefied Petroleum Gas (LPG) / Anhydrous Ammonia Liquid Metering Systems
- 4.4.9. LPG/Anhydrous Ammonia Liquid Metering Systems – Advanced
- 4.4.10. LPG Vapor Meter Systems
- 4.4.11. Mass Flow Metering Systems
- 4.4.12. Other Metering Systems (Cryogenics, Carbon Dioxide, etc.)
- 4.5. Static Volume Measuring Systems – General
 - 4.5.1. Liquid Measures
 - 4.5.2. Farm Milk Tanks
 - 4.5.3. Dry Measures
- 4.6. Other Measuring Systems
 - 4.6.1. Taximeters and Odometers
 - 4.6.2. Wire and Cordage Measuring Systems
 - 4.6.3. Linear Measures
 - 4.6.4. Timing Devices
 - 4.6.5. Weights
 - 4.6.6. Multiple Dimension Measuring Systems
- 4.7. Quality Measuring Systems
 - 4.7.1. Grain Moisture Meters
 - 4.7.2. NIR Grain Analyzers
 - 4.7.3. Carcass Evaluation Systems
- 5. Market Practices, Laws and Regulations (*NIST Handbook 130*) and Commodities (*NIST Handbook 133*)**
 - 5.1. Safety Considerations – Market Practices, *NIST Handbook 130*, *NIST Handbook 133*
 - 5.2. *NIST Handbook 130* – Laws and Regulations
 - 5.2.1. *NIST Handbook 130* – General Provisions
 - 5.2.2. Packaging and Labeling Regulations
 - 5.2.3. Method of Sale Regulations
 - 5.2.4. Quality of Automotive Fuels and Lubricants
 - 5.2.5. Price Verification
 - 5.3. *NIST Handbook 133* – Package Net Contents Control
 - 5.3.1. Commodities – General
 - 5.3.2. Packages Labeled by Weight, Standard and Random
 - 5.3.3. Packages Labeled by Weight, Special Commodities
 - 5.3.4. Packages Labeled by Volume (Volumetric and Gravimetric Testing)
 - 5.3.5. Packages Labeled by Volume, Special
 - 5.3.6. Packages Labeled by Length/Area/Thickness
 - 5.3.7. Packages Labeled by Count
 - 5.3.8. Other Package Types
 - 5.4. Test Purchases
 - 5.5. E-Commerce

Note: Initial Verification has been intentionally been left off this listing and will be addressed later.

Appendix B

History of Professional Certification Program

Source:

Carryover Item 401-1 (This item originated from the Committee and first appeared on its Agenda in 2003 and has undergone continuing development.) The numbering change reflects harmonization in all NCWM reports. Copies of reports from recent years are also available on the website under interim and annual meeting archives pages.

Background/Discussion:

It is important that users of the Professional Certification Program understand how the pieces fit together and form a coherent system. To illustrate the relationships the Committee can describe the system as a triangle of interdependent parts (see diagram below). The standards come in the form of goals with measureable learning objectives. The education part involves training provided to help the candidate reach the desired level of proficiency for each of the learning objectives. The certification involves an assessment of proficiency that measures whether or not the objectives have been met.

Certification Triangle

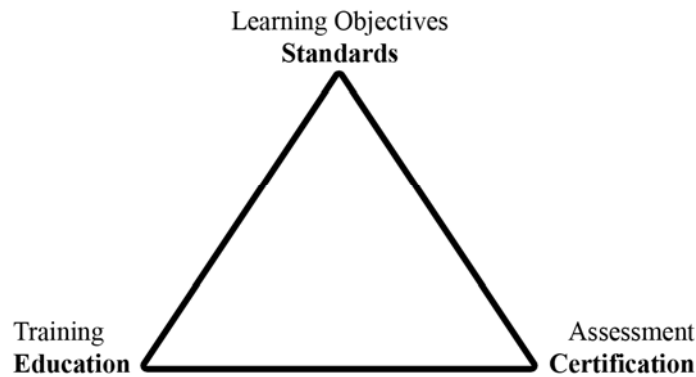

The Committee has until now focused attention on the standards and the certification pieces in the triangle as illustrated in the following flowcharts.

Standard Subsystem

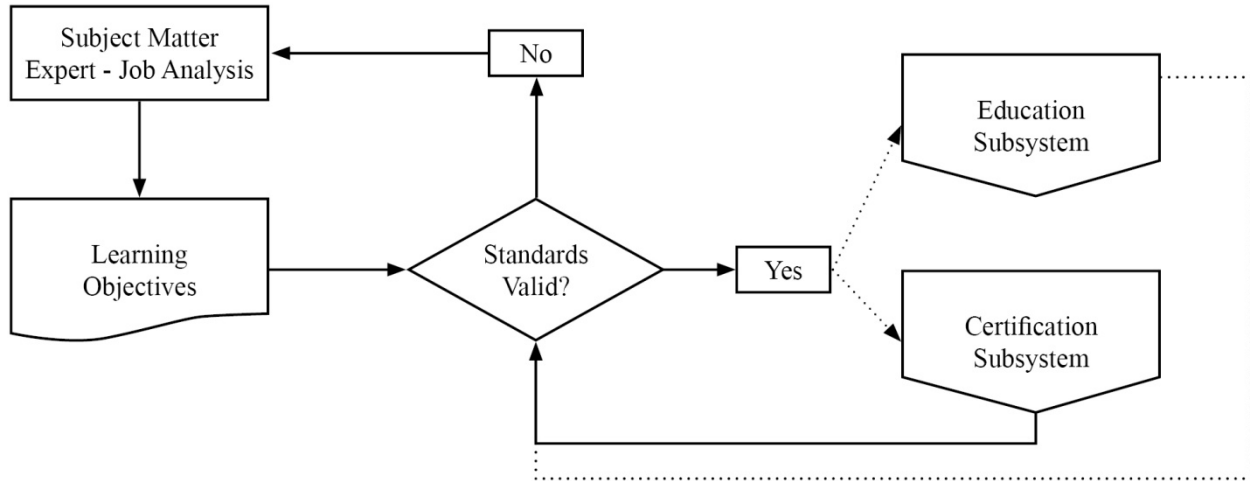

Certification Subsystem

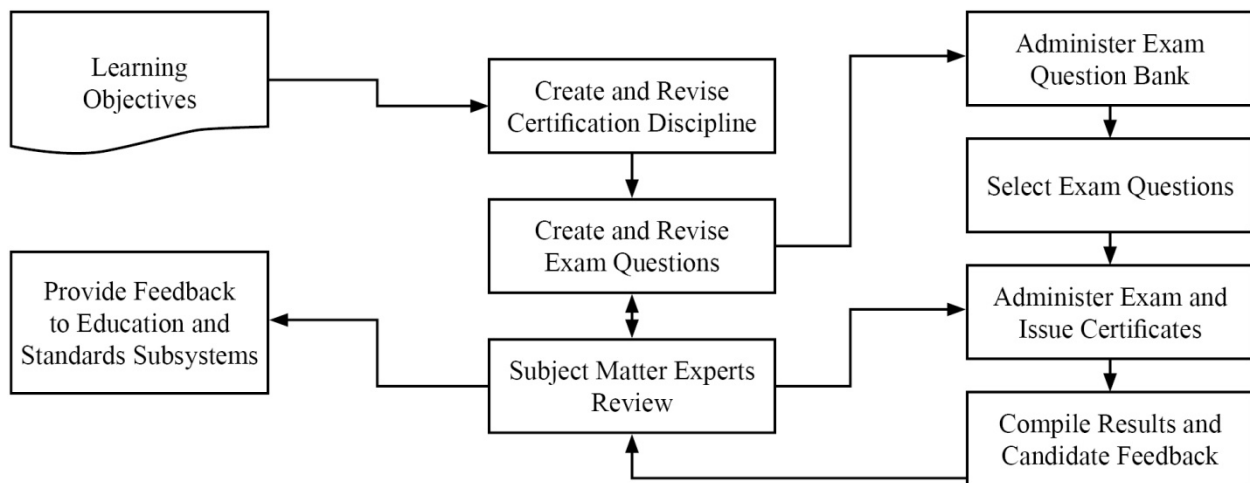

The Committee has described this work in a number of documents. In those documents the Committee is using terminology consistent with current usage in the education and certification field. The following important terms will be used throughout the Committee’s work on the subject.

Body of Knowledge (BOK) – refers broadly to the knowledge and skills required to function as a weights and measures professional. The term may refer broadly to the entire scope of knowledge and skills required within the profession or in a more directed manner to any selected subset for which the particular person is responsible. The BOK describes what you expect the weights and measures professional to achieve as opposed to how he/she will achieve it. To make the BOK more manageable in administration of the Professional Certification Program, it will be subdivided into modules in a tree-like structure moving from general knowledge and skills to more specific.

Module – refers to a group of related subject materials within the *Body of Knowledge Model (BOK)*. The module contains the articulated learning objectives for the subject area. Each module is considered a single, self-contained course of study. However, a broader course may span multiple modules and specific training may include only part of a module or parts of multiple modules. The PDC has created a standard format to create modules for the Professional Certification Program. The Committee has also created the Curriculum Outline and work plans to help manage the work activities within the program to create the many modules necessary to cover the entire profession.

Learning Objective – refers to the articulation of expectations of performance in measureable terms. Learning objectives are stated using active terms to be precise and measureable. There are two types of learning objectives, a terminal objective, and an enabling objective. Terminal objectives state broadly the expectation of performance. The enabling objectives state the specific parts or steps required to demonstrate competence. The PDC has developed a guide to writing the learning objectives for both terminal and enabling which include the active verbs associated with the cognitive levels in Bloom’s Taxonomy. In training, the instructor will typically choose learning activities to explore each of the enabling objectives in an attempt to reach the terminal objective. In assessment, the questions will typically test for competence in each of the enabling objectives to demonstrate that the terminal objectives have been met.

Professional Certification – refers to verification of proficiency relative to all or part of the BOK for the profession as designated by the PDC for inclusion in a certification exam. The selected BOK includes all or part of specific modules, and it is documented in an exam description. Each of the modules, or combinations, is given a specific weighting in the design of the exam. After obtaining a passing score on the exam, the candidate is issued a certificate stating he/she has met the competency standard.

Curriculum – refers to the list of modules that are used to document the BOK (*see Appendix A*).

Bloom’s Taxonomy – refers to a classification of levels of cognitive leaning widely used in the field of education. The levels are knowledge, understanding, application, analysis, integration, and evaluation. The active verbs used in the articulation of learning objectives define the cognitive level. In training, the learning activities are matched to the cognitive level. In assessment, the form of the question is also matched to the cognitive level. The use of Bloom’s Taxonomy is described in detail in the *Body of Knowledge Model* document.

The PDC has prepared program documents that are available on NCWM website.

- The Curriculum Outline, which breaks the profession of weights and measures into component parts called modules.
- The Body of Knowledge Model, which explains how to create modules to document the learning objectives.
- The Modules developed thus far.
- The Certifications developed thus far.

Results of the Retail Motor Fuel Dispensing Systems exam indicate it will be very important as the program moves forward that trainers integrate the learning objectives into their materials and design courses in such a way that candidates will achieve the desired levels of learning. *See Item 401-2 Instructor Improvement.*

2011 NCWM Interim Meeting: The Committee addressed the need to build partnerships between the states, National Institute of Standards and Technology (NIST), Office of Weights and Measures (OWM), and NCWM. Each group has roles in relation to the Certification Triangle as shown in the diagram below.

Professional Certification Program

Applying Certification Triangle (Triumvirate Partnership)

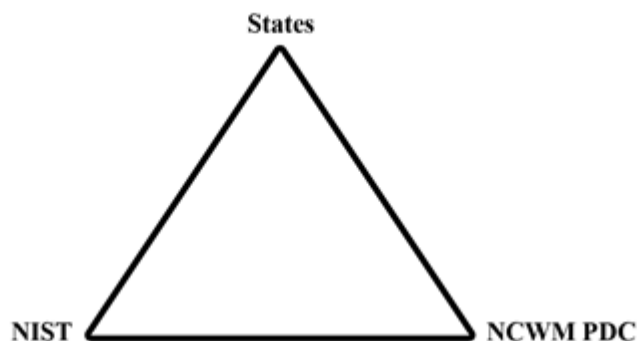

States	NCWM PDC	NIST
<ul style="list-style-type: none">• National Certified Workforce• Assessment Tools and Certification Triangle Applied• Student Meets Training Milestones• Feedback to Trainer and Employee• Value Exam Results = Recognition + Adult Learning• Develop New Training Standards• NCWM/NIST Regional Education and Training	<ul style="list-style-type: none">• Website and Administer Professional Certification Program• Enlist SMEs• Learning Objectives and Standards• Curriculum Work Plans, Discipline, Segments• Write/Verify Exam Questions• Exam Evaluation/Statistical Analysis	<ul style="list-style-type: none">• Training and Education• Instructor Improvement “ADDIE”• State Instruction Support• Technical Materials• Train the Trainer Material• Classroom and Field Training

NCWM 2012 Interim Meeting: The Committee received a comment from NIST OWM that there is a need to provide an assessment tool to measure basic competence in fundamental subject areas such as *NIST Handbook 44*. They hope to partner with NCWM to administer those assessments using NCWM testing service. This would assure that participants at NIST OWM sponsored training possess basic levels of proficiency in prerequisite materials so that instructors can deliver the primary material rather than spend time bringing all students up to the prerequisite level.

The Committee agrees and believes this fits with ongoing efforts to create a BOK and an exam to assess competence in mathematics for the entry level inspector. This could also be a useful tool to any jurisdiction offering training in these basic areas. The Committee will call these baseline competency examinations defined as:

Baseline Competency Examination - refers to verification of proficiency relative to one of the basic modules in the BOK for the profession. After obtaining a passing score on the exam, the candidate is issued a certificate stating he/she has met the competency standard.

The initial modules under consideration for the basic competency examinations are:

- Module XX. Weights and Measures Core Mathematics
- Module 4.2. *NIST Handbook 44* – Introduction to Device Control
- Module 4.3. Weighing Systems – General
- Module 4.4. Dynamic Volume Measuring Systems – General

The BOK document for the Core Mathematics module has been drafted and will be posted on the website and appears in Appendix B.

The professional certifications currently developed (or in development) are:

- Retail Motor Fuel Dispensing Systems (Available)
- Package Checking Basic (Available)
- Small Capacity Weighing Systems Class III (Available) and
- Vehicle Tank Meters (In Development)

The Committee reported that 18 Subject Matter Expert (SME) volunteers are working on the basic package checking exam and 20 SME volunteers are working on the small capacity scale Class III exam. Those exams are nearing completion. Invitations will be sent shortly to NCWM members to solicit SME volunteers to work on the vehicle tank meter exam. The Committee noted that SMEs are the backbone of the program but also that they have competing priorities. One consideration is the idea of doing this work using web meetings, one to brief and train SMEs at the start of a project, and one at the end to resolve any remaining issues with complex questions on the exam. The idea is to minimize the time commitment of our SME volunteers while maintaining high quality in our exams.

The PDC conducted a survey in November 2011 to evaluate priorities for future exam development, appropriate range of device capacities to include in the medium or large capacity scale modules, request feedback from people who had taken the Retail Motor Fuel Dispensing Systems Exam, appropriateness of our examinations for Registered Service Agents (RSA's), and potential problems in standardizing exams on the current NCWM standards.

The Committee received 134 responses covering 25 states, approximately 80 % weights and measures and 20 % industry. Based on the responses the Committee has selected the following subjects for priority development and will be requesting that the Board of Directors extend the Certification Coordinator's contract for these new projects:

- Medium Capacity Scales
- Large Capacity Scales III and IIII
- Liquefied Petroleum Gas (LPG) and Anhydrous Ammonia Liquid
- Price Verification

Survey questions on the Retail Motor Fuel Dispensing Systems Exam indicated that the majority were somewhat or very satisfied with the test taking experience, that the exam questions were appropriate to the basic level inspector, that the questions were straight forward and clearly written, and that they were able to finish in the allotted time. The only problems identified seemed to be related to computer connections and loading of graphics. NCWM staff worked with the testing service to mitigate these issues.

On the issue of using NCWM professional certifications for RSAs, the majority responded with interest in this area. The Committee worked with NCWM staff to solicit RSA volunteers to take the exam for free in order to obtain feedback. Volunteers who passed the exam would receive the formal certificate if they were members or if they pay the \$75 testing fee as non-members. Four RSAs took the exam thus far and others are scheduled to take it. The Committee will gather additional data, evaluate the results, and report at the Annual Meeting.

NCWM 2012 Interim Meeting: Several state officials questioned the appropriateness of charging these volunteers for the certificate if they are non-members. They noted that the service agents invested considerable time in taking the exam so that those who passed could have been rewarded with a waiver of the fee. Mr. Onwiler, NCWM Executive Director, reported that the exam fee structure is controlled by the Board of Directors. The exam fee is waived for members as a way to improve membership value. The exam has always been available to service agents, but this was a means of acquiring volunteers for data collection without making them pay fees as non-members. The Committee verified that participants were advised of the conditions when the volunteers were contacted. The Western Weights and Measures Association (WWMA) made a proposal in 2011 that NCWM consider a tiered membership that would allow for a group rate category or reduced fees for non-members presently employed in a weights and measures related field wishing only to take the examinations. The Committee will ask the Board of Directors to consider these comments.

On the subject of the use of the current NCWM standard as the basis of all exams, the feedback from the survey clearly indicated that this should not be a problem for most jurisdictions. Therefore the Committee will develop all exams based on the current editions of NCWM standards.

Officials had concerns about preparing their workforce for taking the Retail Motor Fuel Dispensing Systems Exam. As the PDC proceeds in offering other certifications, the Committee wants jurisdictions and industry to feel supported and confident that the training they provide for their workforce will be comprehensive and will prepare their people to take the certification exams without providing them with the exam questions. The Committee therefore recommends better communication so they understand what tools are available to help them create their own comprehensive training programs. The critical viewpoint is that a professional has to be prepared to perform the job and not just prepared to take the exam. This is the age old question of training to the learning objectives (the BOK) or training to the exam. The Committee strongly believes that training has to focus on the BOK and not on the exam questions.

NCWM 2012 Annual Meeting: The Committee met with the Board of Directors to provide an update on progress and agree on priorities. The Certification Coordinator reported that two additional question banks for small capacity scales Class III and package checking had passed the technical review and were submitted to NCWM Headquarters.

PDC 2014 Final Report
 Appendix B – History of Professional Certification Program

He also reported that SME volunteers are now working on the vehicle tank meter exam, and that he is expecting to start the search for SME volunteers for the medium and large capacity scale exams shortly after the Annual Meeting. NCWM Executive Director Don Onwiler reported that there has been a slight glitch in the system that must be corrected before two new the exams can be opened for use. This involves making sure that Headquarters controls the individual’s access to exams. Each candidate gets access to initially take the exam and then can get a retest if they fail. The original process had given the candidate access to all exams using the same credentials. As soon as this is corrected they will broadcast the availability of the two new exams.

The idea of accrediting the certification program was discussed. The Executive Director reported that he had been discussing the idea with the Institute for Credentialing Excellence (ICE) to see what parts of our program might be potential stumbling blocks. One area involves the SMEs who develop and vet the test questions. Our problem is that our SMEs are virtually all trainers within their jurisdictions and the vetting and training functions need to be separated. One possible avenue that we are pursuing is to restrict the access each SME has to the exam bank by only allowing them to review a part (~ 1/4) of the test bank. The advice also suggested that SMEs be asked to sign over rights to the test questions and that NCWM seek to copyright its exams. The Committee and the Coordinator will continue to work with the Executive Director toward the goal of meeting the accreditation standards and both the Coordinator and Headquarters will work on documenting procedures as a necessary step in that process. The Executive Director will continue to seek advice towards this long term project from ICE.

The Executive Director provided the Committee and the Board of Directors with following statistics on the Retail Motor Fuel Exam.

	FY 2011	FY 2012
Number of Individuals taking the exam	76	128
Number of Organizations taking the exam	32	68
Number of Exams taken	189 Note(1)	Note (2)
Number of Certificates issued	45	79
Further Breakout		
State Gov’t		86
Local Gov’t		37
Industry		5

Note 1. In the Beta testing phase several took the exam multiple times.

Note 2. Results unavailable yet for FY 12.

The Committee and the Board of Directors agreed that priorities will remain on the Professional Certifications. The Committee will not be pursuing the competency exams. This will help focus efforts to get the exams out based on priorities established by the survey the Committee conducted.

The Committee understands that the SMEs are a critical part of the certification program. The Committee wants to recognize the individuals that are contributing and also encourage others to volunteer on future projects (i.e., the medium and large capacity scale exams) that will start soon. To this end the Committee wants to express gratitude by giving recognition to the following who contributed to the package checking and small capacity scale Class III exams.

Package Checking Basic	Small Capacity Scales Class III
D'Arcy, Carlos, Florida	Smith, Dan, Arkansas
Wilson, Peter, Virginia	D'Arcy, Carlos, Florida
Gurney, Brett, Utah	Wilson, Peter, Virginia
Chesser, Tim, Arkansas	Gurney, Brett, Utah
Merritt, Kevin, Idaho	Chesser, Tim, Arkansas
Shultz, Steve, Nevada	Merritt, Kevin, Idaho
McGee, Robert, South Carolina	Shultz, Steve, Nevada
Hicks, Tyler, Oklahoma	Stokes, John, South Carolina
Johnson, Ray, New Mexico	McGee, Robert, South Carolina
Paquette, Marc, Vermont	Hicks, Tyler, Oklahoma
Tubacki, Jeff, Illinois	Johnson, Ray, New Mexico
Dillibaugh, John, Pennsylvania	Paquette, Marc, Vermont
Miller, Rachelle, Wisconsin	Tubacki, Jeff, Illinois
Feagan, Bruce, Washington	Dillibaugh, John, Pennsylvania
Butcher, Ken, NIST, OWM	Miller, Rachelle, Wisconsin
	Feagan, Bruce, Washington

The Committee heard testimony from a number of individuals during the open hearings and appreciates the comments. In particular, the Committee is very pleased that states are starting to find ways to integrate our standards and the certifications in their programs. One state reported their efforts to mandate in regulation that Registered Service Agents get NCWM certification to demonstrate competence. Another is giving CEUs to county officials who obtain NCWM Certification. Others are using the exam results to evaluate their training efforts. One jurisdiction is using NCWM certifications in labor relations to demonstrate that retention and promotion decisions are being based on an unbiased third party assessment. The CWMA is considering whether it might be possible to use the NCWM exam in their reciprocal testing program for RSAs.

One state director reported that he had his entire staff take the RMFD exam. He provided some valuable feedback that the Committee and the Coordinator will consider. One involved making clear which version of the Handbooks is being used in the exams. He also reported that candidates taking the exam wanted to learn about which questions they got wrong. He also wanted the Committee to look at extending the Certification Program to accredit the overall weights and measures program.

The Committee understands the concern about the wrong answers, but maintaining integrity of the test precludes us from giving that kind of specific feedback on the exam. At the end of the exam, the candidate is provided with the pass/fail on each segment of the exam and the final score. The candidate is also provided with the option of designating the e-mail address where the results will be sent. Thus, the results could go to a supervisor or the director. The Committee is considering avenues to provide feedback that will help states identify potential weaknesses in their training programs. Again, the Committee wants to divert the focus from the test back to ensuring mastery of the learning objectives in the BOK. To that end, the Committee is considering providing general statistics on each part of the exam so that a jurisdiction/company could compare their staff's results with the composite of all those who took the exam. There is a further fear that providing detailed feedback on specific learning objectives where exam results showed low scoring would then divert the focus from the broad objectives of the BOK.

CWMA 2012 Interim Meeting: There was general support for removing much of the content in this item and making it reference material on the NCWM website. There was question regarding how NCWM assesses exam difficulty and a suggestion to look at professional certification programs for other industries to see what the passing rates are and what they use to know if the exams are at the appropriate difficulty level. There were several suggestions to improve the exam process, including a flag button on each test question that test takers could select to notify that a specific question was problematic. Another was to provide a direct link at the end of the test to a survey site or other site for immediate feedback on the test. Another suggestion was to disclose to test takers which areas of NIST Handbook 44 they should study based on their results, without being told the actual questions that were incorrect. This would maintain the integrity of the test while providing guidance to the test taker.

WWMA 2012 Annual Meeting: The WWMA PDC chair presented a PowerPoint presentation reviewing the Professional Certification Program (PCP) entitled “Using the NCWM Program” during the open hearings. One comment/question was received during the open hearings regarding the time limit to take an exam after an individual has registered and received their passcode. The Committee, in conversation with the NCWM Executive Director by telephone, confirmed that there is no time limit for initial log in or between taking the first and second exam. Furthermore, if a NCWM member fails the second exam, he or she can reapply and retest until they pass the exam, free of charge. The Committee discussed the draft FAQ sheet developed by Mr. Ross Andersen and recognized that it is a good start and is in need of further development. The Committee is willing to assist with enhancing and clarifying this document. The Committee discussed the exam result data compiled on the three exams to date. The RMFD exam has been available since 2010. The Package Checking Basic and Small Capacity Scales Class III have been available since August 2012. The Committee recognized the likelihood that the pass/fail rate on the exams to date may not reflect the difficulty of the exam since many may be taking the exams to familiarize themselves with the exam process, not necessarily for obtaining the certificate. The Committee discussed accreditation of the PCP, the benefits to both industry and regulatory individuals, and the issue created by crossover between persons serving as both Subject Matter Experts (SMEs) and trainers. The Committee discussed the difference between certification to demonstrate basic competency, accreditation, and licensing with continuing education requirements. The Committee believes that for the PCP to be accredited, more information is needed about the specific accreditation requirements so the NCWM Professional Development Committee (NCWM PDC) can efficiently and correctly design the Program. The Committee encouraged the WWMA audience to take one or more of the three exams that are available. The Committee discussed the need for volunteer SMEs, exam results data, and feedback on the exam taking experience, to assist the NCWM PDC in the continuous improvement of existing exams, and development of future exams. Feedback can be submitted to the NCWM PDC through NCWM via e-mail to info@ncwm.net or call (402) 434-4880. The concept of free exams or a “rollback” in pricing for a period of time was discussed. There may be jurisdictions, business organizations, or other entities that desire to take the exams, but find the cost of membership is prohibitive. The Committee believed there might need to be an initial incentive to encourage participation. The Committee recommends the following:

- NCWM survey jurisdictions to find out the number of Registered Service Agents (RSA) within the jurisdiction, whether these jurisdictions require the RSA to pass an examination, and what fees and timelines are associated with these requirements; Determining the number of jurisdictions that require licensing and the content of their examinations, e.g. regulatory vs. technical requirements, would allow the NCWM PDC to evaluate the appropriateness of administering the same exams for RSA’s or development of separate exams particular to RSA’s. The jurisdictions using these written exams in their training programs could do so in conjunction with a field component to certify inspectors and RSA’s.
- NCWM Executive Director continue research into the accreditation requirements and recommend the appropriate accreditation body for the PCP; Weights and measures jurisdictions and industry organizations that may require certification recognize the value and credibility provided through formal accreditation.
- NCWM PDC continue its work refining the PCP FAQ Sheet. The WWMA PDC Committee is willing to assist with enhancing and clarifying this document; The PCP FAQ Sheet is a valuable tool for new exam takers.
- NCWM PDC consider implementing a policy of offering newly introduced exams at a reduced price for a fixed period of time (e.g., \$30 per exam for six months) providing the exam taker agree to provide feedback

on the exam contents and exam taking experience before receiving their certificate. NCWM needs to encourage the widest possible participation in the early stages of PCP development. To bring the PCP to full program fruition, offering incentives to exam takers may assist the NCWM in reaching its goals.

One jurisdiction indicated that they would begin using the examinations as part of their annual performance plans and performance evaluations for their staff. The Committee realized that the PCP was originally designed for weights and measures officials, but discussed whether the exams should be modified for RSA to put more emphasis on proper calibrations, sealing, etc.

THIS PAGE INTENTIONALLY LEFT BLANK

Appendix C

History of Instructor Improvement

Source:

Carryover Item 401-3 (This item originated from the Committee and first appeared on its agenda in 2003.)

Background/Discussion:

Prior to the 2010 Annual Meeting, Ms. Harris, NIST OWM, provided the Committee with reference material on teaching methods and assessment of training success. Distilling the essence of these materials, the Committee believes that instructors need training in more than just the technical material; they need training in setting the learning objectives, developing the training materials with those objectives in mind, selecting training methods that incorporate adult learning styles, and evaluating the effectiveness of their training.

Education Subsystem

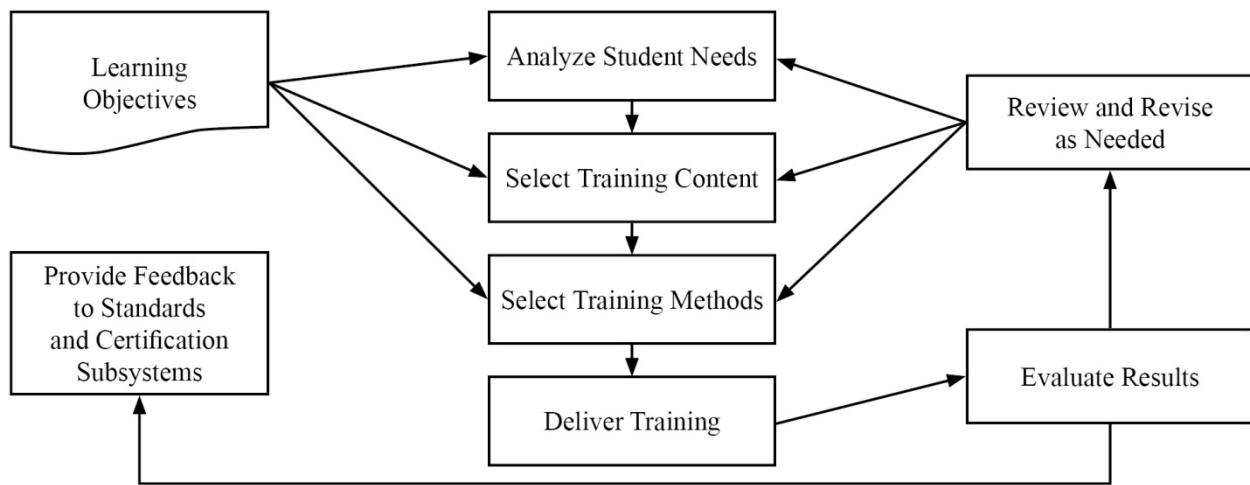

The chart below covers three levels of learning objectives and relates them to (1) the training activities most likely to be successful and (2) the best methods for assessing the success of the training. The curriculum segments state the learning objectives using verbs similar to those in the bottom row of the table. These drive both the training activities required to promote adult learning and the assessment tools appropriate to measure success at that level.

Assessments	Multiple Choice	Multiple Choice	Practical Examples Short Answer
Training Activities	Lecture Videos Examples	Discussion Review Learner Presentation	Exercises Simulations Demonstrations
Cognitive Levels	Knowledge	Comprehensive	Application
	Define Relate List	Restate Discuss Describe Identify	Employ Apply Use Illustrate

NIST, OWM has expressed strong interest in collaborating with NCWM in efforts to educate instructors in adult learning techniques and relating them to the learning objectives in NCWM curriculum. The Committee will be posting NIST, OWM material on converting technical content to training material on the PDC training resources web pages. The importance of pre-training analysis and post-training evaluation cannot be overestimated. Failure to include these steps often leads to failure of training efforts.

Professional Certification Program
Systems Approach to Training Evaluation

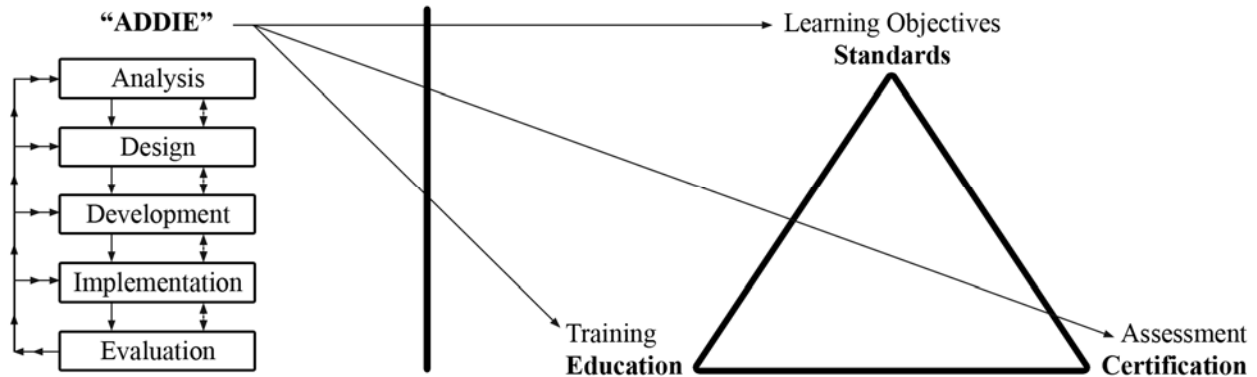

The Committee is calling on the states and other training developers to implement the Analysis, Design, Development, Implementation, and Evaluation (ADDIE) model in their training preparations and post training evaluation. Everyone needs to participate in the development of new BOK modules and then encourage their trainers to use existing BOK modules in their training plans.

The Committee encourages members to also look at the presentation on *A Complete Training Program* prepared by Carol Hockert, NIST, OWM. The presentation outlines ways to develop training programs and improve instruction of weights and measures material. Contact Ms. Hockert for a copy.

NCWM 2012 Interim Meeting: Advisors from NIST, OWM reported that they are using NCWM BOK in preparing new training initiatives. They are stressing adult learning techniques, particularly focusing on the use of hands-on training as the most popular and effective training tool. This ties in closely with the new baseline competency exams discussed in Item 410-1. NIST, OWM is using these exams to ensure students in NIST sponsored training courses are competent in prerequisite course materials prior to taking training. They reported that they are already drafting questions for the baseline competency exams. They see significant efficiencies in using NCWM testing services for this purpose since they are already in place.

Ms. Hockert, NIST, OWM, recommended a basic math prerequisite for persons taking Metrology or other related weights and measures courses sponsored by NIST. The math exam would allow trainees to demonstrate entry level math skills and make the training process more efficient and effective. One official discussed the California licensing requirement of a college degree which requires a certain number of math courses and asked if this would satisfy the need for the math prerequisite. Several California officials expressed concern about the Professional Certification Program replacing existing state licensing programs, and if adopted it might require amendment of existing state statutes. Because math competency is an essential skill for weights and measures work, the Committee recommends that the PDC include in its scope the development of an exam to demonstrate basic math competency before taking the Fundamentals of Metrology or other training courses at NIST.

SWMA 2011 Annual Meeting: It was stated that we should consider training state trainers on adult learning techniques as well as subject matter. No further recommendations were made.

NCWM 2012 Annual Meeting: The Committee stressed instructor improvement. The Committee reviewed the importance of using the NCWM learning objectives and the ADDIE model in training. This stresses the importance of training to the goals in the Body of Knowledge and not training to pass the test. If the training is appropriate and has been delivered effectively, the employee should have no problem passing a fair exam. The end is not a certificate on the wall, but rather a competent inspector. In other words;

JOB SUCCESS = EXAM SUCCESS

Carol Hockert, NIST OWM, stressed that good training requires a partnership between the trainee, trainer, and the supervisor. The Committee agrees that buy-in from all levels is critical to training success.

CWMA 2012 Interim Meeting: The Committee recommended archiving most of the content in this item to the NCWM website as reference material.

WWMA 2012 Annual Meeting: The Committee noted it is in the best interest of NIST and NCWM that regional training efforts be of the highest quality and uniform throughout the United States. The Committee recommends the following:

- Regional trainers be selected as per the process agreed upon between NIST and NCWM;
- Regional trainers receive courses on adult learning techniques and converting technical information into training materials;
- Regional trainers be afforded the opportunity to shadow NIST trainers as they perform training in individual jurisdictions; and
- The use of funds from the Associate Membership Committee or the NIST Training Initiative Grant is made available for this purpose.

NEWMA 2012 Interim Meeting: Members expressed interest in NIST Train-the-Trainer classes. A demonstration was provided on how to access materials for taking the Professional Certification Exams and then for taking the exams. The Committee encouraged those in attendance to seek certification of their inspectors.

THIS PAGE INTENTIONALLY LEFT BLANK

Appendix D

Training Manual

A Competency-Based Evaluation Scale

Numerical/Adjective Rating:

5 = Outstanding

Can perform this skill without supervision or assistance with proficiency in speed, quality quantity, self-initiative, reliability and judgment; can lead or assist others in performing this skill.

4 = Above Standard

Can perform this skill consistently within established standards of speed, quality and quantity without assistance and / supervision.

3 = Standard

Can perform this skill generally consistent with established standards of speed, quality and quantity, but requires periodic assistance and or supervision.

2 = Short of Standard

Can perform this skill only with some assistance and or supervision to insure consistency with established standards of speed, quality and quantity; Able to perform some parts of the skill, but cannot perform the entire skill.

1 = Unacceptable

Has limited ability or knowledge to perform this skill; Continuous assistance and or supervision required; Performance does not meet established standards of speed, quality and quantity; Demonstrates possible problems in having the learning ability to acquire the skill.

Not Responsive to Training

Has been repeatedly instructed in a particular subject matter and still fails to demonstrate a knowledge of the subject or is unable to perform the particular task which would exhibit this knowledge, the training instructor should rate the new inspector NRT the training instructor the narrative comments the training attempted and the results of the new inspectors attempt to perform the task.

Interpersonal Skills For Field Training Inspectors

Commitment to service:

Predisposition to seek responsibility
Responsive to the public need
Responsive to the goals of the Department and weights and measures

Oral Communication and Listening:

Conveying ideas to another in a coach-pupil atmosphere
Clear and Concise in nature
Responsive to the trainee's needs
Ability to adjust to the personality of the trainee
Patience

Flexibility:

Ability to adapt to changing conditions as needed

Planning and Organizing:

Implementing decisions according to a timeline
Utilizing resources at your disposal to achieve a desired result
Knowledge of subject matter

Follow Through:

Verifying effectiveness
Assessing results
Timely response to inquires

Essential FTI Duties

Observer:

Patient oversight of the trainee
Allowing the trainee to act, then giving feedback as to performance
Implies listening as well as viewing

NATIONAL WEIGHTS AND MEASURES FIELD TRAINING PROGRAM

INSPECTOR ROUTINE OBSERVATION REPORT

STANDARDIZED EVALUATION GUIDELINES

PERFORMANCE

1. **REPORT WRITING:**

NEEDS IMPROVEMENT

General inability to accurately organize a concise, understandable report in a timely fashion:

- a. Omission or misstatement of facts
- b. Elements of violation missing/incomplete inspections
- c. Confusing or misleading narrative
- d. Continual spelling errors
- e. Consistent improper grammar
- f. Illegible
- g. Excessive time used

COMPETENT

General ability to write reports accurately in organized and timely fashion:

- a. Complete statement of facts
- b. Specific violation elements delineated/completes thorough inspections
- c. Legible
- d. Minimal spelling errors
- e. Correct grammar
- f. Concise, understandable language
- g. Reasonable time used in completion of necessary reports

2. **DRIVING SKILLS:**

NEEDS IMPROVEMENT

Incorrect evaluation of driving situations with loss of vehicle control:

- a. Continually violates Vehicle Code
- b. General disregard for public safety
- c. Involvement in preventable accidents
- d. Inappropriate use of safety lighting equipment
- e. Excessive and inappropriate speed
- f. Inability to exit vehicle safely

NATIONAL WEIGHTS AND MEASURES FIELD TRAINING PROGRAM
ROUTINE OBSERVATION REPORT (ROR)
(DOCUMENTED AT LEAST WEEKLY)

TRAINEE:

FTI:

DATE:

PHASE:

DATE:

RATING INSTRUCTIONS: Rate observed performance of trainee in the following categories.

*NI = Needs Improvement; **C = Competent; NO = Not Observed

A. PERFORMANCE

1. Report Writing	NI	C	NO
2. Driving Skills: Routine	NI	C	NO
3. Self-initiated Activity	NI	C	NO
4. Knowledge of locations	NI	C	NO
5. Stress Control: Verbal/Behavior	NI	C	NO
6. Safety: Self/Others	NI	C	NO
7. Violator Control: Verbal/Physical	NI	C	NO
8. Decision-Making/Problem-Solving	NI	C	NO
9. Coordination: Multiple Tasks	NI	C	NO

B. INTERPERSONAL SKILLS

1. Communication Skills	NI	C	NO
2. Acceptance of Criticism	NI	C	NO
3. Behavior Toward Citizens	NI	C	NO
4. Behavior Toward regulatory Personnel	NI	C	NO
5. Self-Image/Confidence	NI	C	NO

C. KNOWLEDGE

1. Agencies Policies/Procedures	NI	C	NO
2. Enforcement Codes	NI	C	NO
3. Resources	NI	C	NO
4. Inspection Procedures/Techniques	NI	C	NO

D. JOB READINESS

1. General Appearance	NI	C	NO
2. Forms/Equipment /Specialized Equipment	NI	C	NO
3. Informed on Current Issues/Community Problems	NI	C	NO

TRAINEE SIGNATURE

FTO SIGNATURE

TRAINING PROGRAM FOR DEPARTMENT OF COMMERCE WEIGHTS AND MEASURES INVESTIGATOR I TRAINEE

I. PURPOSE

Very few, if any, entry level candidates for Weights and Measures Investigator I positions have well-rounded experience working with weighing and measuring devices. Even candidates from private industry involved in the manufacture or repair of weighing and measuring devices normally have experience with only one or two types of devices, and are not familiar with the principals of legal metrology, or have experience working as government regulators. A significant training period is necessary to teach candidates with demonstrated aptitudes the specific skills they need to function successfully as a Weights and Measures Investigator I before they are able to work on their own and assume responsibility for a territory.

This training program is designed to facilitate the recruitment of entry level candidates capable of mastering the required skills including minority and women applicants in conjunction with the Department of Commerce's Affirmative Action Program.

II. METHODS FOR TRAINEE SELECTION

Job openings will be posted on the state employment website as light duty or heavy duty territories become vacant. The posting will make it clear whether the vacancy being posted is a light duty or a heavy duty position. Jobs will also be advertised on electronic sites or in print publications aimed at women and minorities in an effort to get a candidate pool which is representative of the state's population. Application is via resume on the state employment website. All resumes are reviewed to find candidates who possess the following prerequisite capabilities:

- Ability to interact in a professional manner with a wide variety of people including co-workers, members of the public, business owners and service agents, and employees of other government agencies such as the DNR and the MPCA;
- Ability to communicate complex technical information coherently in both written and verbal formats ;
- Ability to work independently with little supervision and to manage scheduling and routing work in a large territory;
- Computer skills sufficient to work from a remote laptop through a VPN connection;
- Mechanical skills sufficient to maintain their vehicles, test equipment and standards in good condition, as well as to assess the likelihood of mechanical tampering in the weighing and measuring devices they inspect;
- Physical ability to walk, stand and sit for extended periods of time, to lift up to fifty pounds repeatedly throughout the day, and to work outside in all weather conditions for up to ten hours a day;

THIS PAGE INTENTIONALLY LEFT BLANK

Report of the National Type Evaluation Program (NTEP) Committee

Mr. Stephen Benjamin, Chairman
North Carolina

500 INTRODUCTION

This is the report of the NTEP Committee (hereinafter referred to as the “Committee”) for the 99th Annual Meeting of the National Conference on Weights and Measures (NCWM). This report is based on the Interim Report offered in the NCWM Publication 16, testimony heard at public hearings, comments received from the regional weights and measures associations and other parties, the NCWM 2014 Online Position Forum, the addendum sheets issued at the Annual Meeting, and actions taken by the membership at the voting session of the Annual Meeting. The informational items presented below were adopted as presented when the Committee’s report was approved.

Table A identifies the agenda items and appendix items. The agenda items in the Report are identified by Reference Key Number, title, page number and the appendices by appendix designations. The acronyms for organizations and technical terms used throughout the agenda are identified in Table C. The first three digits of the Reference Key Numbers of the items are assigned from The Subject Series List. The status of each item contained in the report is designated as one of the following: **(D) Developing Item:** the Committee determined the item has merit; however, the item was returned to the submitter or other designated party for further development before any action can be taken at the national level; **Informational (I) Item:** the item is under consideration by the Committee but not proposed for Voting; **(V) Voting Item:** the Committee is making recommendations requiring a vote by the active members of NCWM; **(W) Withdrawn Item:** the item has been removed from consideration by the Committee.

Table B provides a summary of the results of the voting on the Committee’s items and the report in its entirety. Some Voting Items are considered individually, others may be grouped in a consent calendar. Consent calendar items are Voting Items that the Committee has assembled as a single Voting Item during their deliberation after the Open Hearings on the assumption that the items are without opposition and will not require discussion. The Voting Items that have been grouped into consent calendar items will be listed on the addendum sheets. Prior to adoption of the consent calendar, the Committee entertains any requests from the floor to remove specific items from the consent calendar to be discussed and voted upon individually.

Proposed revisions to the handbook(s) are shown as follows: 1) deleted language is indicated with a **bold face font using strikeouts** (e.g., ~~this report~~), 2) proposed new language is indicated with an **underscored bold faced font** (e.g., new items), and 3) nonretroactive items are identified in *italics*. When used in this report, the term “weight” means “mass.”

Note: The policy of NIST is to use metric units of measurement in all of its publications; however, recommendations received by NCWM technical committees and regional weights and measures associations have been printed in this publication as submitted. Therefore, the report may contain references to inch-pound units.

Subject Series List

Introduction	500 Series
International.....	510 Series
Activity Reports.....	520 Series
Conformity Assessment Program	530 Series
NCWM Publication 14, Administrative Policy	540 Series
Other Items – Developing Items.....	550 Series

**Table A
Table of Contents**

Reference Key	Title of Item	Page NTEP
500	INTRODUCTION	1
510	INTERNATIONAL	3
510-1	Mutual Recognition Arrangement (MRA).....	3
510-2	Mutual Acceptance Arrangement (MAA)	4
520	ACTIVITY REPORTS.....	5
520-1	NTEP Participating Laboratories and Evaluations Reports	5
520-2	NTEP Sector Reports.....	6
530	CONFORMITY ASSESSMENT PROGRAM.....	8
530-1	Conformity Assessment Program	8
540	NCWM PUBLICATION 14 – NTEP ADMINISTRATIVE POLICY.....	11
540-1	20.3.1.1. Certification Body’s Responsibilities	11
550	OTHER ITEMS – DEVELOPING ITEMS.....	13
550-1 D	NTEP Contingency Plan.....	13

Appendices

A	Item 520-1: NTEP Statistics Report	A1
B	Item 520-2: Belt-Conveyor Scale Sector Meeting Summary	B1
C	Item 520-2: Grain Analyzer Sector Meeting Summary.....	C1
D	Item 520-2: Measuring Sector Meeting Summary	D1
E	Item 520-2: Software Sector Meeting Summary	E1
F	Item 520-2: Weighing Sector Meeting Summary	F1

**Table B
Voting Results**

<i>Reference Key Number</i>	<i>House of State Representatives</i>		<i>House of Delegates</i>		<i>Results</i>
	<i>Yeas</i>	<i>Nays</i>	<i>Yeas</i>	<i>Nays</i>	
Report	Voice Vote				Adopted

Table C
Glossary of Acronyms and Terms

Acronym	Term	Acronym	Term
AQL	Acceptable Quality Level	MTL	Manufacturers' Testing Laboratories
B	Basic Publication	NCWM	National Conference on Weights and Measures
CC	Certificate of Conformance	NIST	National Institute of Standards and Technology
CIML	International Committee of Legal Metrology	NTEP	National Type Evaluation Program
CTT	Conformity to Type	NTETC	National Type Evaluation Technical Committee
DoMC	Declaration of Mutual Confidence	OIML	International Organization of Legal Metrology
IV	Initial Verification	OWM	Office of Weights and Measures
MAA	Mutual Acceptance Arrangement	R	Recommendation
MC	Measurement Canada	SC	Technical Subcommittee
MDMD	Multiple Dimension Measuring Devices	TC	Technical Committee
MRA	Mutual Recognition Arrangement	VCAP	Verification Conformity Assessment Program

Details of All Items
(In order by Reference Key)

510 INTERNATIONAL

510-1 Mutual Recognition Arrangement (MRA)

Background/Discussion:

The MRA between Measurement Canada (MC) and NTEP labs originated April 1, 1994. Since that time, the original MRA has expanded, and a second MRA covering measuring devices was developed. On Tuesday July 19, 2011, NCWM Chairman Mr. Tyson and MC President Mr. Johnston signed a renewal MRA that combines the weighing and measuring devices into one document and provides for continued cooperation between the two organizations and continuation of the beneficial partnership. The new MRA is effective for five years.

The scope of the current MRA includes:

- gasoline and diesel dispensers;
- high-speed dispensers;
- gasoline and diesel meters intended to be used in fuel dispensers and truck refuelers;
- electronic computing and non-computing bench, counter, floor, and platform scales with a capacity up to 1000 kg (2000 lb);

- weighing/load receiving elements with a capacity of up to 1000 kg (2000 lb);
- electronic weight indicating elements (except those that are software based [i.e., programmed by downloading parameters]); and
- mechanical scales up to 10 000 kg (20 000 lb).

MC, NTEP, and all of our mutual stakeholders agree that the MRA is a benefit for the North American weights and measures industry. The NTEP Committee appreciates the efforts and cooperation of Measurement Canada. The Committee continues working with MC to explore the possibility of expanding the scope to include Multiple Dimension Measuring Devices (MDMD) and higher capacity scales. Technical obstacles have prevented inclusion of both MDMD and higher capacity scales for now, but NTEP and MC remain committed to continue to discuss expansion. NTEP also requested that tests conducted at manufacturers' premises under the supervision of an NTEP evaluator be included in the scope of the MRA. MC expressed the desire to keep these evaluations outside the scope of the MRA for scales, load receiving elements, and electronic weight indicating elements.

NCWM private sector members continue to reiterate their desire to see MDMD included under the MRA. MC and the NTEP Committee continue to discuss and evaluate matters regarding such an expansion of the MRA. During the 2013 Annual Meeting, MC agreed to give further consideration to expansion of the MRA to include MDMDs and to recognition of data collected by NTEP evaluators at manufacturing facilities. During the 2014 Interim Meeting, MC expressed their interest in including MDMDs under the MRA. NTEP has notified the MDMD Work Group and has charged them with: 1) identifying differences in requirements and test procedures; 2) making recommendations to harmonize NIST Handbook 44 when appropriate; and 3) making recommendations to change NCWM Publication 14 as deemed appropriate.

Mettler-Toledo commented that their company has experienced MRA application issues due to differences in the test weights used for evaluation of high precision Class I and II balances. NTEP will discuss the issues with MC.

During the 2014 Annual Meeting, MC announced their agreement to accept test data recorded by an NTEP evaluator at a manufacturer's facility, as per the NTEP contingency plan, if the test site and test plan were agreed upon prior to testing.

The NTEP Committee is in discussion with MC to include Multiple Dimension Measuring Devices (MDMD) in the MRA. MC is requesting that they be the primary laboratory for MDMD evaluations conducted under the MRA. The Committee is requesting input from U.S. manufacturers and the MDMD Work Group (WG). A meeting of the MDMD WG has been scheduled for October 28-29, 2014 in Reynoldsburg, OH.

510-2 Mutual Acceptance Arrangement (MAA)

Background/Discussion:

Information regarding the International Organization of Legal Metrology (OIML) MAA can be found at www.oiml.org/maa. NCWM has signed the OIML MAA Declaration of Mutual Confidence (DoMC) for Recommendation (R) 60 Load Cells as a utilizing participant. A utilizing participant is a participant which does not issue any OIML Certificate of Conformance (CC) nor OIML Test Reports and/or Test Reports under a DoMC but does utilize the reports issued by issuing participants.

A meeting of the Committee on Participation Review (CPR) for R 60 and R 76 was held September 21 - 23, 2011, in Braunschweig, Germany. Dr. Ehrlich, National Institute of Standards and Technology (NIST), Office of Weights and Measures (OWM); Mr. Barton, NIST, OWM; and Mr. Truex, NCWM attended the meeting. A recent meeting of the CPR was hosted by NIST March 18 - 19, 2014, and was attended by Dr. Ehrlich, Mr. Barton, and Mr. Darrell Flocken, NCWM.

The United States (NTEP) supported the OIML B 10 documents for the MAA with the provision that the use of manufacturer test data was clearly identified on the MAA test report because NTEP cannot use manufacturer test data towards issuance of an NTEP certificate. Consequently, the OIML voted and approved the Amendment to B 10 to allow the inclusion of test data from manufacturers, on a strictly voluntary basis, at its October 2012 meeting in

Bucharest, Romania. Dr. Ehrlich gave an update to the Committee during the 2013 Interim Meeting, reviewing the history of the above discussions, deliberations, and CIML votes, confirming that the outcomes aligned with the NTEP Committee's recommendations and the instructions provided by the NCWM Board of Directors.

Dr. Ehrlich requested in January 2013 that NCWM review its MAA policy regarding participation in R 76. The NCWM Board recapped the decision process to participate as a utilizing participant for R 60. Existing policy from 2006 is not to participate in R 76 until NCWM is able to do so as an Issuing Participant. The Board revisited the 2006 discussions leading to that decision, including considerations for NTEP labs' workload, potential lost expertise, concerns with quality of evaluations at some foreign labs, etc. Dr. Ehrlich wanted NCWM to reconsider and, if there was no possibility in sight that the NCWM could become an Issuing Participant, then it should consider becoming a Utilizing Participant for OIML R 76. Some U.S. manufacturers support NCWM policy, but others would like to have one-stop shopping. The MAA also includes R 51 (water meters) and R 117 (RMFD) may be added soon. Since there are no new developments to effect the decision, the NCWM Board of Directors agree to maintain existing policy at this time.

From January 2011 to June 2014, 32 NTEP certificates for load cells were issued under the MAA. The NTEP Administrator reviewed all MAA test data and drafted the CCs.

520 ACTIVITY REPORTS

520-1 NTEP Participating Laboratories and Evaluations Reports

Background/Discussion:

During the 2014 Annual Meeting, Mr. Truex, NTEP Administrator, updated the Committee on NTEP laboratory and administrative activities.

The NTEP weighing and measuring laboratories held a joint meeting April 2 - 4, 2013, in Greensboro, North Carolina. The NTEP laboratories, NTEP Committee, and NCWM Board of Directors expressed appreciation to Gilbarco for allowing the NTEP measuring laboratories to utilize their facilities and equipment for hands on training. Special thanks were extended to Gordon Johnson and Gilbarco employees that participated in the training exercises.

The NTEP weighing laboratories met in August 2013 prior to the meeting of the NTEP Weighing Sector in Albany, New York, and the NTEP measuring laboratories met in October 2013, prior to the NTEP Measuring Sector meeting in Charleston, West Virginia. The 2014 meeting of the NTEP Participating Laboratories was held April 1 - 3 in Albany, New York.

In 2011 the Committee announced plans survey NTEP customers and NTEP laboratories regarding customer service. The survey is released to active CC holders. The Board routinely reviews the results of the survey to form a continuous improvement plan for NTEP. With any survey, the challenge is to develop a document that is concise enough that customers will respond, while also providing a meaningful set of data. To date, the NCWM Board of Directors is finding general approval of NTEP services.

During the 2014 Annual Meeting, Mr. Truex updated the Committee on NTEP laboratory and administrative activities. The Committee reviewed NTEP statistics through June 2014. The review of statistics shows that incoming applications are relatively comparable to normal, and there exist no significant laboratory backlog issues.

The State of Oregon has expressed their intent to pursue authorization as an NTEP Participating Field Laboratory for large capacity weighing devices. NTEP is working with Oregon toward that goal.

520-2 NTEP Sector Reports

Background/Discussion:

All NTEP Sector reports were available to members at the time NCWM Publication 15 was published. The NTEP Committee is committed to ensuring that electronic versions of Sector reports are available with NCWM Publication 15 in the future. Please note that the Sector reports will only be available in the electronic version of NCWM Publication 15 at ncwm.net/meetings/interim/archive; they will not be available in the printed versions of NCWM Publication 15.

NTEP Belt-Conveyor Scale Sector:

The NTEP Belt-Conveyor Scale Sector last met February 22 - 23, 2012, in St. Louis, Missouri. A final draft of the meeting summary was provided to the Committee prior to the 2013 NCWM Interim Meeting for review and approval (See Appendix B). A meeting for the Sector had been scheduled for February 19 - 20, 2013, in North Carolina. The meeting was cancelled due to a lack of significant NTEP agenda items; however, a meeting of the U.S. National Work Group was held.

The NTEP Belt-Conveyor Scale Sector meeting was held February 20, 2014 in Pittsburgh, Pennsylvania. For questions on the current status of Sector work or to propose items for a future meeting, please contact the Sector Technical Advisor:

Technical Advisor

Mr. John Barton
NIST, OWM
100 Bureau Drive, MS 2600
Gaithersburg, MD 20899
Phone: (301) 975-4002
Fax: (301) 975-8091
E-mail: john.barton@nist.gov

NTEP Grain Moisture Meter and NIR Protein Analyzer Sectors:

The NTEP Grain Moisture Meter and NIR Protein Analyzer Sectors held a joint meeting in Kansas City, Missouri, August 20 - 21, 2013. A draft of the final summary was provided to the Committee prior to the 2014 NCWM Interim Meeting for review and approval. (See Appendix C)

The next meeting of the NTEP Grain Moisture Meter and NIR Protein Analyzer Sectors is scheduled for August 20-21, 2014, in Kansas City, Missouri. For questions on the current status of Sector work or to propose items for a future meeting, please contact the Sector Technical Advisor:

Technical Advisor

Ms. G. Diane Lee
NIST, OWM
100 Bureau Drive, MS 2600
Gaithersburg, MD 20707
Phone: (301) 975-4005
Fax: (301) 975-8091
E-mail: diane.lee@nist.gov

NTEP Measuring Sector:

The NTEP Measuring Sector met October 9 - 10, 2013, in Charleston, West Virginia. A draft of the final summary was provided to the Committee prior to the 2014 NCWM Interim Meeting for review and approval. (See Appendix D.)

The next meeting of the NTEP Measuring Sector Meeting is scheduled for October 3 - 4, 2014, in Raleigh, North Carolina, in conjunction with the Southern Weights and Measures Association's 2014 Annual Meeting. For

questions on the current status of Sector work or to propose items for a future meeting, please contact the Sector Technical Advisor:

Technical Advisor

Mr. Clark Cooney
NIST, OWM
100 Bureau Drive, MS 2600
Gaithersburg, MD 20899
Phone: (301) 975-4615
Fax: (301) 975-8091
E-mail: clark.cooney@nist.gov

NTEP Software Sector:

The NTEP Software Sector met March 19 - 20, 2013, in Columbus, Ohio. A final draft of the meeting summary was provided to the Committee prior to the 2014 NCWM Interim Meeting for review and approval. (See Appendix E.)

The next meeting of the NTEP Software Sector is scheduled for August 27 - 28, 2014, in Atlanta, Georgia. The first day of the meeting will be a joint meeting of the NTEP Weighing and Software Sectors. For questions on the current status of Sector work or to propose items for a future meeting, please contact the Sector Chair and/or the NTEP Administrator:

Chair

Mr. James Pettinato
FMC Technologies Measurement Solutions, Inc.
1602 Wagner Avenue
Erie, PA 16510
Phone: (814) 898-5250
Fax: (814) 899-3414
E-mail: jim.pettinato@fmcti.com

NTEP Administrator

Mr. Jim Truex
NCWM
1135 M Street, Suite 110
Lincoln, NE 68508
Phone: (740) 919-4350
Fax: (740) 919-4348
E-mail: jim.truex@ncwm.net

NTEP Weighing Sector:

The NTEP Weighing Sector met August 27 - 28, 2013, in Albany, New York. A final draft of the meeting summary was provided to the Committee prior to the 2014 NCWM Interim Meeting for review and approval (see Appendix F).

The next NTEP Weighing Sector meeting is scheduled for August 26 - 27, 2014, in Atlanta, Georgia. The second day of the meeting will be a joint meeting of the NTEP Weighing and Software Sectors. For questions on the current status of Sector work or to propose items for a future meeting, please contact the Sector Technical Advisor:

Technical Advisor

Mr. Rick Harshman
NIST, OWM
100 Bureau Drive, MS 2600
Gaithersburg, MD 20899
Phone: (301) 975-8107
Fax: (301) 975-8091
E-mail: richard.harshman@nist.gov

The NTEP Committee reviewed and approved all 2013 NTEP Sector reports during the 2014 Interim Meeting.

The Board has approved a meeting of the Multiple Dimension Measuring Device Work Group for October 28 - 29, 2014, at the Ohio Department of Agriculture complex in Reynoldsburg, Ohio. For more information contact WG Chair Mr. Robert Kennington (rkennington@cubiscan.com), or NTEP Specialist Mr. Darrell Flocken (darrell.flocken@ncwm.net).

530 CONFORMITY ASSESSMENT PROGRAM

530-1 Conformity Assessment Program

Background/Discussion:

The Conformity Assessment Program was established to ensure devices produced after the device has been type-evaluated and certified by NTEP continue to meet the same requirements. This program has three major elements: 1) Certificate Review (administrative); 2) Initial Verification (inspection and performance testing); and 3) Verified Conformity Assessment (influence factors). This item is included on the Committee's agenda to provide an update on these elements.

Certificate Review:

Certificates are constantly under review by NTEP staff and laboratories. Many active certificates are amended annually because of manufacturer submission for evaluation or issues reported by the states pertaining to information on the certificate. When the devices are re-evaluated and certificates are amended, all information is reviewed and necessary steps are taken to assure compliance and that accurate, thorough information is reported on the certificate.

In an effort to keep certificate information up to date, the Committee continues to offer an opportunity for active certificate holders to update contact information that is contained in the "Submitted By" box on certificates. This is offered during the payment period of their annual maintenance fee. Many Certificate of Conformance (CC) holders have taken advantage of the opportunity.

Initial Verification (IV):

The IV initiative is ongoing. Field enforcement officials perform an initial inspection and test on new installations on a routine basis. The Committee recognized that the states do not want IV reporting to be cumbersome.

An IV report form has been developed. The Committee desired a simple form, perhaps web-based for use by state and local regulators. The form has been approved by the Committee and distributed to the states. A completed form can be submitted via mail, e-mail, fax, or online. The form is available to regulatory officials who are members of NCWM at www.ncwm.net/ntep/conformity/verification.

During the 2014 Annual Meeting, NTEP acknowledged that the regulators have not bought into the IV report form. Industry representatives stated that IV is very important to ensure conformity assessment and the NCWM should push harder for reporting of non-compliance issues found during IV.

VCAP:

NCWM has been concerned about production meeting type and protecting the integrity of the NTEP CC since the inception of NTEP. The board has consistently reconfirmed its belief that conformity assessment is vital to NTEP's continued success.

Load cells traceable to NTEP certificates were selected for the initial assessment effort. NCWM elected to require a systems audit checklist that is to be completed by an outside auditor and submitted to NCWM per Section 221.3.3.3.5 of the VCAP requirements. A VCAP Systems Audit Checklist for Manufacturers and a VCAP Systems Audit Checklist for Private Label Certificate Holders have been developed and are available on the website at www.ncwm.net/ntep/conformity/vcap/checklists-faqs. Additionally, the Committee developed a new NCWM Publication 14, administrative policy to distinguish between the requirements for parent NTEP certificate holders (21.3.3.2) and private label certificate holders. The requirements in 21.3.3.7. track the private label checklist requirements: traceability to parent NTEP CC, traceability of the private label cell to a VCAP audit, purchase and sales records, plan to report non-conforming product and non-conforming product in stock, plan to conduct internal audits to verify non-compliance action, and internal audit records.

As a result of VCAP activities, 24 load cell certificates, involving 12 different certificate holders, were changed to "inactive" status.

In 2012, the Committee announced that the next device category is weighing/load receiving elements, 2000 lb capacity and less, using load cells that are not traceable to their own NTEP certificate. The following compliance timeline was developed for weighing/load receiving element CC holders with active certificates using non-NTEP load cells. The Committee encourages affected certificate holders to start the process immediately.

NCWM/NTEP VCAP Compliance Timeline Weighing/Load Receiving Element, 2000 lb Capacity and Less Using Non-NTEP Load Cells					
January 2012 – Ongoing	July 2012 – November 2013	July 2012 – May 2014	July 2012 – November 2013	December 2013	June 2014
<ul style="list-style-type: none"> • NTEP to review and refine VCAP procedures • NTEP answers incoming questions • NTEP notifies active CC holders of VCAP requirements 	<ul style="list-style-type: none"> • Parent CC holders to put VCAP QM system in place • CC holder to have audit conducted by Certified Body • Submit audit report to NCWM/NTEP 	<ul style="list-style-type: none"> • Private Label CC holders to put VCAP QM system in place • CC holder to have audit conducted by Certified Body • Submit audit report to NCWM/NTEP 	<ul style="list-style-type: none"> • NTEP evaluates incoming audit reports • NTEP contacts CC holders not meeting VCAP requirements to encourage compliance 	<ul style="list-style-type: none"> • NCWM declares CCs inactive if Parent CC holder fails to comply with VCAP 	<ul style="list-style-type: none"> • NCWM declares CCs inactive if Private Label CC holder fails to comply with VCAP

NTEP reported that 25 weighing element certificate holders (44 active NTEP CCs) were identified and all were notified. The following disclaimer has been advertised and communicated by NCWM: “NCWM is working to identify all active certificates for weighing elements 2000 lb capacity and less, using non-NTEP load cells. As a courtesy, certificate holders are being notified of VCAP requirements and the established timeline. Please note that the NCWM Board of Directors does not consider it to be NCWM's responsibility to notify all certificate holders and affected certificates. Certificate holders are responsible for reviewing their active NTEP certificates and compliance with VCAP.” As a result of VCAP, 13 certificates, involving 10 different certificate holders, were declared inactive January 1, 2014.

The Committee has received letters, questions, and many other inquiries pertaining to VCAP. The Committee has worked diligently to answer the questions submitted in a very timely manner. The Committee knows that additional questions will be posed as VCAP progresses. Certificate holders and other interested parties are encouraged to submit written questions to the NTEP Committee. The Committee is pleased to report that it has been successful in answering all the questions to date. Clerical changes have been made to affected VCAP documents as deemed necessary.

The Committee had discussions about the required number of audits for facilities that manufacture multiple device types. For example, if a company had successful audits for two device types, they might submit a request for a delay from audit requirements for remaining device types, stating that they are all subjected to the same processes and will be audited in the next cycle. The Committee agreed to the request in principal and directed the NTEP Administrator to develop NCWM policy language for consideration during the next Board meeting. As a result the following policy was adopted by the NCWM Board in October 2013.

Adding Device Categories to VCAP:

Purpose: To establish criteria for NTEP and NTEP certificate holders who have successfully completed a VCAP audit in the proper response when a new device category is added to the VCAP.

Background: It has come to the attention of the NTEP Committee that when a new device category is added to the VCAP, the addition might create a potential problem for NTEP certificate holders who have already successfully completed a VCAP audit. The request submitted asks NTEP to recognize previous VCAP audits when adding new device types to the VCAP. It makes sense to allow certificate holders, who have already successfully completed a

VCAP certification audit, to cover the new device category under their existing quality management system until the due date of their next VCAP audit. Once all the device types have been added, the question will become moot within three years since the next regularly scheduled audit will address all device types within that facility. Likewise, NTEP already applies the same philosophy when a new model is introduced by the same certificate holder. That is, the new model is considered covered by the audit because it is a process audit, not a device evaluation. This effectively allows a certificate holder to conduct a single audit for all device categories under the VCAP umbrella.

Policy:

When a new device category is added to the VCAP requirement, NTEP will recognize the current VCAP audit certification in effect, submitted by a certificate holder, for the same certificate holder and same production facility(s), to cover the new device category, continue the manufacturing process for devices covered by NTEP certificates in the newly added device category, until the due date of the next VCAP audit.

Example: If a company had successful audits for two device types, they might submit a request for exemption from audit requirements for remaining device types, stating that they are all subjected to the same quality management system and will be included in the next audit cycle. The next VCAP audit must be done within three years of the last audit and address all applicable device types produced within that facility.

Seven weighing device categories subject to influence factors, as defined in NIST Handbook 44, were identified and are subject to VCAP audits. The VCAP process requirement is ongoing for load cells and weighing elements that use non-NTEP load cells. Certificate holders for these device types are encouraged to take note that the NTEP Committee and NCWM Board is seriously considering the application of the VCAP requirement to all five remaining categories in the very near future. If and when the VCAP requirements are applied, the certificate holder would be required to have an on-site audit of the manufacturer's quality system and on-site random and/or review of a production device by an outside auditor to verify compliance with VCAP. Certificate holders are encouraged to research the VCAP requirements on the NCWM website under the NTEP, Conformity Assessment section. Certificate holders are encouraged to review the VCAP requirements applicable to their devices and report concerns to the NTEP Committee. It is important to reiterate that the NCWM Board of Directors does not consider it to be NCWM's responsibility to notify all certificate holders. Certificate holders are responsible for reviewing their active NTEP certificates and compliance with VCAP.

An NTEP Committee proposal to expand VCAP was advertised prior to the Annual Meeting, on the NCWM website and during this Annual Meeting via a handout. The Committee was strongly considering inclusion into the Verified Conformity Assessment Program of Electronic Weighing Instruments and Main Elements with capacities ≤ 2000 lbs of the following Device Types:

- Complete Scales*,
- Indicating Elements,
- Automatic Weighing Systems,
- Weighing/Load Receiving Elements,
- Belt-Conveyor Scales, and
- Automatic Bulk Weighing Systems.

This includes both Manufacturers and Private Label Holders of Certificates of Conformance (CC) for these Device Types.

*The category of complete scales includes types such as but not limited to Computing, Non-computing Point of Sale, Crane, Monorail, Hopper, and Grain Test Scales.

During the 2014 Annual Meeting, the Committee heard objections from several companies to expanding VCAP to all the device types. The Committee also heard objections to weighing/load receiving elements being included on the list of device types. It became obvious to the Committee that there is a difference in interpretation stemming from the conflicting list of device types in Publication 14 Administrative Policy (specifying weighing/load receiving elements using non-NTEP load cells) versus the list of devices to be tested for influence factors in Publication 14, DES, Technical Policy (specifying weighing /load receiving elements).

The Committee decided to only include indicating elements at this time and approved developed timeline below. Certificate holders should take notice that the other categories will be considered and may be added in the very near future. The Committee will continue to take comments pertaining to the weighing elements conflict and ask the NTEP Weighing Sector for input.

NCWM/NTEP VCAP Compliance Timeline Indicating Elements					
Jan 2015 – March 2015	Jan 2015 – May 2016	Jan 2015 – Nov 2016	Jan 2015 – Dec 2016	Jun 2016	Dec 2016
NTEP notifies active CC holders of VCAP requirements	Parent CC holders to put VCAP QM system in place	Private Label CC holders to put VCAP QM system in place	NTEP evaluates incoming audit reports	NCWM declares CCs inactive if Parent CC holder fails to comply with VCAP	NCWM declares CCs inactive if Private Label CC holder fails to comply with VCAP
	CC holder to have audit conducted by Certified Body	CC holder to have audit conducted by Certified Body	NTEP contacts CC holders not meeting VCAP requirements to encourage compliance		
	Submit audit report to NCWM/NTEP	Submit audit report to NCWM/NTEP			

540 NCWM PUBLICATION 14 – NTEP ADMINISTRATIVE POLICY

540-1 20.3.1.1. Certification Body’s Responsibilities

Source:
NTEP Committee

Purpose:
Clarify that NCWM employees may perform VCAP audits under the NTEP Conformity Assessment Program.

Item under Consideration:
Amend NCWM Publication 14, Administrative Policy as follows:

21.3.3 NTEP Verified Conformity Assessment Program Procedures

Many NTEP certified devices must meet NIST Handbook 44 requirements for influence factors. It is not possible to verify these requirements during the Initial Verification in the field. Therefore, manufacturers of metrological devices (instruments) and/or components (modules) which are subject to influence factors, as defined in NIST Handbook 44, must have a Verified Conformity Assessment Program (VCAP) in place to ensure that these metrological devices and/or components are produced to perform at a level consistent with that of the device and/or component previously certified. The Verified Conformity Assessment Program audit will be at one or more sites as required to verify compliance.

For weighing devices that are subject to influence factors, NTEP will require an initial on-site audit of the manufacturer’s quality system and on-site random testing and/or review of a production device(s) (instrument(s)) by the Registrar **or an NCWM authorized technical employee** to verify that all items listed below are currently implemented and functioning to verify compliance to the appropriate sections of NIST Handbook 44.

It is important for NTEP to know the types of devices included in the VCAP audit and it is for this reason that the certificate holder shall prepare a controlled quality management system (QMS) document listing the range of parameters that cover the devices included in the audit. The certificate holder shall include in this document all certificates and device parameters (For example: different models, capacities, e-min, n-max, sizes etc.) for the applicable device category. For example, in a load cell audit, a range of capacities of the load cells included in the audit shall be listed in the report. This document shall be available for the VCAP auditor and NTEP upon request and may be included as an annex to the audit report if desired.

21.3.3.3 Certification Body’s Responsibilities and NCWM Technical Employee Responsibilities:

21.3.3.3.1 The selected Certification Body is to be accredited by ANSI-ASQ National Accreditation Board (ANAB). The ANSI-ASQ National Accreditation Board is the U.S. accreditation body for management systems. ANAB accredits certification bodies (CBs) for ISO 9001 quality management systems (QMS) and ISO 14001 environmental management systems (EMS), as well as a number of industry-specific requirements, or equivalent.

21.3.3.3.2 With accreditation to Standard Industry Classification (SIC) codes (3596/3821) or equivalent.

<u>Sequence Number</u>	<u>2007 NAICS, U.S. Code</u>	<u>2007 NAICS U.S. Title</u>
847	333997	Scale and Bench Manufacturing

21.3.3.3.3 The selected Certification Body shall have international auditors available.

21.3.3.3.4 The Certification Body **or NCWM technical employee** is required to notify NCWM when a major breakdown of the NTEP CC holder’s VCAP program is found.

21.3.3.3.5 The Certification Body **or NCWM technical employee** shall submit a completed “Systems Audit Checklist” to NCWM. Submitted documents must contain a clear statement of compliance as a result of the VCAP audit.

Background/Discussion:

NCWM has hired a new employee who will serve in many facets of the NTEP Activities. One such activity is the Verified Conformity Assessment Program. In addition to reviewing the audit reports submitted to NCWM, the employee will also be available to follow up on audits and conduct VCAP audits. NCWM has establish fees comparable to those of other organizations providing similar services to ensure that it is not underpricing and putting those organizations at a competitive disadvantage on pricing.

As VCAP expands to reach the full scope of the NTEP Administrative Policy in Publication 14 there may be a lack of available auditors to meet the demand. Audits are required every three years at each facility and many are in process now of undergoing their second audits.

During the 2014 Annual Meeting, the Committee heard comments complimenting the actions taken by NCWM and heard a request that the supplemental guide go into more detail pertaining to the test sample selection criteria. NTEP is working to improve the guide.

550 OTHER ITEMS – DEVELOPING ITEMS

550-1 D NTEP Contingency Plan

Source:

NTEP Committee

Purpose:

NTEP Contingency Plan was created to keep NTEP operating and to ensure that NTEP services are available at an adequate level including an appropriate number of laboratories and personnel (evaluators) to maintain viable support for NTEP services, including MRAs, MAAs, and potentially to be an R 76 Issuing Participant.

Item Under Consideration:

The NTEP Committee discussed contingency planning for continuity of NTEP operations. With the state of today’s economy, one of the NTEP-authorized labs could close due to government budget cuts. How would NTEP maintain workflow? Are there additional states interested in applying to become an NTEP field lab or an NTEP brick-and-mortar lab? The 2014 hiring of an NTEP Specialist helps with contingency concerns. The Committee continues to discuss these issues during long-range planning sessions and welcomes comments from the membership.

Background/Discussion:

The Committee continues to consider whether NCWM should:

1. Have additional evaluators under contract to conduct testing at manufacturers’ facilities and assist state NTEP laboratories?
2. Have an NCWM brick and mortar NTEP laboratory and NTEP evaluators?
3. Use a private third party laboratory to conduct NTEP evaluations?
4. OIML MAA Participation as an issuing or utilizing participant.

The Committee has heard testimony expressing support and concerns pertaining to the options. Several stated that the Committee should consider adding OIML MAA participation as a Utilizing Participant to the list. Others have urged the Committee to continue working on the idea of NCWM NTEP evaluators, an NCWM NTEP lab, and keeping all options open. One member asked the Committee to consider accepting manufacturer compliance data in lieu of hiring NTEP contractors. Another suggestion from the floor was to consider strengthening and utilizing IV as part of the NTEP process. A representative of a state brick and mortar NTEP laboratory asked the Committee to move cautiously forward and not destroy the state NTEP labs. He expressed concern that the establishment of an NCWM NTEP brick and mortar lab could lead to significant legal complications for the states.

The Committee continues to reiterate to the membership that, at this time, the preferred course of action would be the option of evaluators under contract or use NCWM NTEP staff to assist the laboratories. The Committee recognizes the commitment that the states with NTEP laboratories have made over the years and would only resort to contingency measures in the event of a severe loss of state lab resources. Labs are handling current demands without a need for contingency measures. The Committee is updated on the status of the participating laboratories, personnel, and backlog on a quarterly basis and will continue to keep NTEP contingency a priority.

-
- Mr. Stephen Benjamin, North Carolina | Committee Chair
 - Mr. John Gaccione, Westchester County, New York | NCWM Chairman
 - Mr. Ron Hayes, Missouri | Chairman-Elect
 - Mr. James Cassidy, City of Cambridge, Massachusetts | Member
 - Mr. Jerry Buendel, Washington State | Member
 - Mr. Jim Truex, NCWM | NTEP Administrator

National Type Evaluation Program Committee

THIS PAGE INTENTIONALLY LEFT BLANK

Appendix A

NTEP Statistics Report

General NTEP Statistics		Last Year	This Year	Grand Total
		10/01/12 – 9/30/13	10/01/13 – 6/30/14	10/1/00 – 6/30/14
Total Applications Processed		(8) 255	(32) 251	(184) 3538
Applications Completed		252	230	3436
New Certificates Issued		253	214	3062
Active NTEP Certificates on 6/30		1977	1887	

() = Reactivations

Assignments to Labs per Year		10/1/12 – 9/30/13	10/1/13 – 6/30/14	10/1/00 – 6/30/14
California		(1) 38	29	(17) 475
Canada		2	1	(4) 46
GIPSA-DC		1	0	17
GIPSA-KC		9	6	102
Maryland		(7) 50	(2) 35	(46) 453
New York		(2) 10	7	(19) 180
NIST Force Group		4	4	(1) 96
North Carolina		8	20	(4) 140
Ohio		62	37	(28) 876
NTEP Staff		(2) 70	109	(12) 1019
Applications Not Yet Assigned to a Lab			6	

() = Reassignments from another lab

Process Statistics	2013 - 2014	2000 - 2014
Average Time to Assign an Evaluation	3.8 Days	8.6 Days
Average Time to Complete an Evaluation		131.2 Days

Report on Evaluations in Progress

Evaluations in Progress	0-3 Months	3-6 Months	6-9 Months	9-12 Months	Over 1 Year	Total
June 30, 2010	37	12	11	13	24	97
October 30, 2010	40	30	8	8	20	106
December 31, 2010	39	25	22	5	20	111
March 31, 2011	37	27	13	19	17	107
June 30, 2011	47	20	7	7	21	102
September 30, 2011	42	28	11	5	19	105
December 31, 2011	37	19	23	5	17	101
March 31, 2012	40	17	7	21	14	99
June 30, 2012	41	21	10	6	20	98
September 30, 2012	50	30	15	7	19	121
December 31, 2012	32	24	17	7	18	98
March 31, 2012	36	12	14	12	18	92
June 30, 2013	53	18	6	6	19	102
September 30, 2013	44	32	5	4	21	106
December 31, 2013	41	25	24	2	24	116
March 31, 2014	53	23	13	17	11	117
June 30, 2014	55	30	14	8	19	126

In Progress by Lab	0-3 Months	3-6 Months	6-9 Months	9-12 Months	Over 1 Year	Total
California	7	6	5	0	7	25
Canada	0	1	0	0	0	1
GIPSA-DC	0	0	0	0	1	1
GIPSA-KC	4	2	0	1	1	8
Maryland	6	5	3	1	1	16
New York	1	1	1	0	0	3
NIST Force Group	1	0	2	2	2	7
North Carolina	6	8	2	1	1	18
Ohio	9	2	1	3	6	21
NTEP Staff	16	4	0	0	0	20
Unassigned	5	1	0	0	0	6
					Total Pending:	126

Report on Applications Received by Quarter

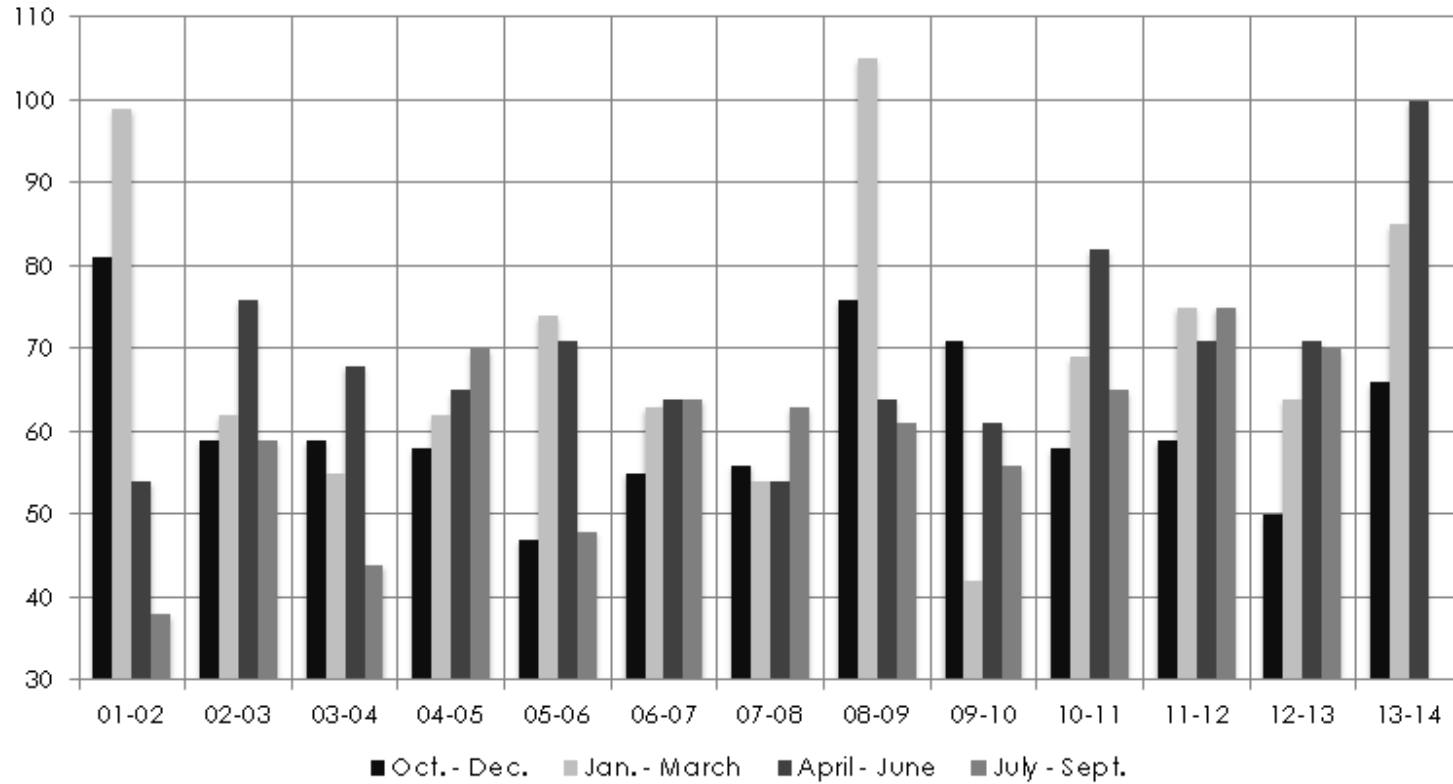

NTEP - A3

	01-02	02-03	03-04	04-05	05-06	06-07	07-08	08-09	09-10	10-11	11-12	12-13	13-14
Oct - Dec	81	59	59	58	47	55	56	76	71	58	59	50	66
Jan - Mar	99	62	55	62	74	63	54	105	42	69	75	64	85
Apr - Jun	54	76	68	65	71	64	54	64	61	82	71	71	100
Jul - Sep	38	59	44	70	48	64	63	61	56	65	75	70	
Total	272	256	226	255	240	246	227	306	230	274	280	255	251

Average Per Quarter Overall: 65.1

Average Per Quarter This FY: 83.7

THIS PAGE INTENTIONALLY LEFT BLANK

Appendix B

National Type Evaluation Technical Committee (NTETC) Belt-Conveyor Scale (BCS) Sector Meeting Summary

No meeting took place for 2013.

INTRODUCTION

The charge of the BCS Sector is important in providing appropriate type evaluation criteria based on specifications, tolerances and technical requirements of NIST Handbook 44, *Specifications, Tolerances, and Other Technical Requirements for Weighing and Measuring Devices*, Sections 1.10. General Code and 2.21. Belt-Conveyor Scale Systems. The Sector's recommendations are presented to the NTEP Committee each January for approval and inclusion in NCWM Publication 14, *Technical Policy, Checklists and Test Procedures* for national type evaluation.

The Sector is also called upon occasionally for technical expertise in addressing difficult NIST Handbook 44 issues on the agenda of the National Conference on Weights and Measures (NCWM) Specifications and Tolerances (S&T) Committee. Sector membership includes industry, NTEP laboratory representatives, technical advisors and the NTEP Administrator. Meetings are held annually, or as needed and are open to all NCWM members and other registered parties. The BCS Sector did not meet during 2013; therefore, there is no 2013 report.

Suggested revisions are shown in **bold face print** by ~~striking out~~ information to be deleted and **underlining** information to be added. Requirements that are proposed to be nonretroactive are printed in ***bold faced italics***.

Note: It is the policy of the National Institute of Standards and Technology (NIST) to use metric units of measurement in all of its publications; however, recommendations received by NCWM technical committees and regional weights and measures associations have been printed in this publication as submitted. Therefore, the report may contain references in inch-pound units.

THIS PAGE INTENTIONALL LEFT BLANK

Appendix C

National Type Evaluation Technical Committee (NTETC) Grain Analyzer Sector Meeting Summary

August 21 - 22, 2013
Kansas City, Missouri

INTRODUCTION

The charge of the NTETC Grain Analyzer Sector is important in providing appropriate type evaluation criteria based on specifications, tolerances and technical requirements of NIST Handbook 44, *Specifications, Tolerances, and Other Technical Requirements for Weight and Measuring Devices*, Sections 1.10. General Code, 5.56. Grain Moisture Meters and 5.57. Near-Infrared Grain Analyzers. The Sector’s recommendations are presented to the National Type Evaluation Program (NTEP) Committee each January for approval and inclusion in NCWM Publication 14, *Technical Policy, Checklists, and Test Procedures* for national type evaluation.

The Sector is also called upon occasionally for technical expertise in addressing difficult NIST Handbook 44 issues on the agenda of National Conference on Weights and Measures (NCWM) Specifications and Tolerances (S&T) Committee. Sector membership includes industry, NTEP laboratory representatives, technical advisors, and the NTEP Administrator. Meetings are held annually, or as needed and are open to all NCWM members and other registered parties.

Proposed revisions to the handbook(s) are shown as follows: 1) deleted language is indicated with a **bold face font using strikeouts** (e.g., ~~this report~~), 2) proposed new language is indicated with an **underscored bold faced font** (e.g., new items), and 3) nonretroactive items are identified in *italics*. There are instances where the Sector will use **red** text and/or **highlighted** text to bring emphasis to text that requires additional attention. When used in this report, the term “weight” means “mass.”

Note: It is the policy of the National Institute of Standards and Technology (NIST) to use metric units of measurement in all of its publications; however, recommendations received by NCWM technical committees and regional weights and measures associations have been printed in this publication as submitted. Therefore, the report may contain references in inch-pound units.

Table A
Table of Contents

Title of Content	Page NTEP C
INTRODUCTION	1
1. Report on the 2013 NCWM Interim and Annual Meetings	3
2. Report on NTEP Evaluations and Ongoing Calibration Program (OCP) (Phase II) Testing	3
3. Review of OCP (Phase II) Performance Data	4
4. Amend Table S.2.5. of §5.56.(a) in NIST Handbook 44 - Update	4
4.a. Proposed Changes to Table S.2.5. in Appendix C of the GMM Chapter of Publication 14.....	6
4.b. Proposed Changes to the Checklist of the GMM Chapter of Publication 14	8
4.c. Proposed Changes to the Checklist of the NIR Grain Analyzer Chapter of Publication 14.....	8
5. Item 356-1 Printed Ticket User Requirements – Update	8
6. Modify the Definition of Remote Configuration Capability Appearing in Appendix D of NIST Handbook 44 to Recognize the Expanded Scope of “Remote Configuration Capability” (S&T Developing Item 360-7)	12

7.	Status of Interagency Agreement and Impact of UGMA (new GIPSA designated) Meter on Another 5-year Agreement.....	15
8.	Near Infrared Corn NTEP Support.....	17
9.	Test Weight per Bushel Acceptance and Maintenance Tolerance	19
10.	Report on International Organization of Legal Metrology (OIML) TC 17/SC 1 R 59 <i>Moisture Meters for Cereal Grains and Oilseeds</i> and proposed changes to the NTEP humidity test for grain moisture meters and near infrared grain analyzers.....	22
11.	Report on OIML TC 17/SC 8 Protein Measuring Instruments for Cereal Grain and Oil Seeds	25
12.	Software Sector Items	26
13.	Update on Proficiency Testing.....	36
14.	The Feasibility of a Phase II program for Near Infrared Grain Analyzers	38
15.	Next Sector Meeting	38
16.	Update on the New Meter Technology	39

Table B
Glossary of Acronyms and Terms

Acronym	Term	Acronym	Term
BIML	International Bureau of Legal Metrology	NTETC	National Type Evaluation Technical Committee
CD	Committee Draft	OCP	Ongoing Calibration Program
CIML	International Committee of Legal Metrology	OIML	International Organization of Legal Metrology
CIPM	International Committee of Weights and Measures	OWM	Office of Weights and Measures
D	Document	R	Recommendation
EMRP	European Metrology Research Program	S&T	Specifications and Tolerances
FGIS	Federal Grain Inspection Service	SC	Subcommittee
GA	Grain Analyzer	SD	Secure Digital
GIPSA	Grain Inspection, Packers and Stockyards Administration	TC	Technical Committee
GMM	Grain Moisture Meter	TW	Test Weight
MRA	Mutual Recognition Agreement	UGMA	Unified Grain Moisture Algorithm
NCWM	National Conference on Weights and Measures	USB	Universal Serial Bus
NIR	Near Infrared Grain Analyzer	USDA	United States Department of Agriculture
NIST	National Institute of Standards and Technology	USNWG	United States National Working Group
NTEP	National Type Evaluation Program		

Details of All Items
(In order by Reference Key)

1. Report on the 2013 NCWM Interim and Annual Meetings

The 2013 NCWM Interim Meeting was held January 27 - 30, 2013 in Charleston, South Carolina. At that meeting, no recommended amendments to NCWM Publication 14 for grain analyzers were provided to the NTEP committee. Several of the recommended changes to NCWM Publication 14 that were discussed at the 2012 Sector meeting were pending voting at the 2013 Annual Meeting and will be reviewed later in Agenda Item 4 as proposed changes to the 2013 edition of NCWM Publication 14. See the table of ammendments and changes to NCWM Publication 14 below.

The 2013 NCWM Annual Meeting was held July 14 - 18, 2013, in Louisville, Kentucky. There were two Grain Analyzer Sector voting items on the agenda. **Item 356-1, Table S.2.5. Categories of Device and Methods of Sealing** and **Item 356-2, UR.3.4. Printed Tickets**. See Grain Analyzer agenda Item 4, and agenda Item 5 below, for details. There was also one Grain Analyzer Sector Developing item on the S&T agenda, **Item 360-7, Appendix D – Definitions: Remote Configuration Capability**. See Grain Analyzer agenda Item 6, below, for details.

Mr. Jim Truex, NTEP Administrator, reported that 37 states were represented at the NCWM 2013 Annual Meeting. Jim also provided an overview of the **structure** of NCWM Inc., Handbook 44, and NCWM Publication 14. At the Annual Meeting, **Item 356-1, Table S.2.5. Categories of Device and Methods of Sealing** and **Item 356-2, UR.3.4. Printed Tickets** were adopted. **Item 360-7, Appendix D – Definitions: Remote Configuration Capability** remains a Developing item for additional input from the Sectors.

Amendments/Changes to the Grain Moisture Meters and Near Infrared Grain Analyzer Chapters in the 2013 Edition of NCWM Publication 14			
Section Number	Amendment/Change	Page (2013 Edition)	Source: 2013 Grain Analyzer Sector Meeting Summary
Appendix C Table S.2.5 Categories of Device and Methods of Sealing	Amend Category 3 to remove the word “remotely” from the second paragraph. Add a paragraph to Category 3a and 3b	GMM-37	Agenda Item 4.a.
GMM Checklist Code Reference: S.2.5. Provisions for Sealing - Category 3 devices	Amend paragraph 4.6.36 and 4.6.37 to reflect the changes that were made in Appendix C, Table S.2.5	GMM-21	Agenda Item 4.b.
NIR Checklist Code Reference S.2.6. Provisions for Sealing	Amend paragraph 4.9.16. to delete remotely and add “OR” following the sentance in 4.9.16.1	NIR-15	Agenda Item 4.c.

2. Report on NTEP Evaluations and Ongoing Calibration Program (OCP) (Phase II) Testing

Ms. Cathleen Brenner, Grain Inspection, Packers and Stockyards Administration (GIPSA), the NTEP Participating Laboratory for grain analyzers brought the Sector up to date on NTEP Evaluation (Phase I) activity. She also reported on the collection and analysis of Grain Moisture Meter OCP (Phase II) data on the 2012 crop. Ms. Brenner will identify, for the 2013 harvest, the models enrolled in Phase II.

Ms. Brenner reported that there are three models enrolled in Phase I and one of those models is near completion and will be joining models enrolled in the Phase II program for the 2013 harvest. The second model is enrolled for moisture and the third model for extending the temperature ranges.

Ms. Brenner also reported on the collection and analysis of Grain Moisture Meter OCP (Phase II) data on the 2012 crop. For the 2013 harvest there are seven models enrolled in Phase II. The manufacturers will be charged on the basis of six models because, using GAC2500-UGMA data, DICKEY-john can automatically back calculate calibrations to the GAC2500 without having to run samples on the GAC2500*. Phase II data collection for the 2013 harvest began in early August.

The seven meters:

1. Bruins Instruments – OmegAnalyzerG
2. DICKEY-john Corp. – GAC2000 (NTEP Version), GAC2100a and GAC2100b
3. DICKEY-john Corp. – GAC2500 (*See note above. Will not run samples on this model.)
4. DICKEY-john Corp. – GAC2500-UGMA
5. Foss North America – Infratec 1241
6. Perten Instruments Inc. – AM5200 and AM5200-A (The AM5200-A is UGMA Certified.)
7. The Steinlite Corporation – SL95

The 2013 Phase II enrollment cost to each manufacturer, based on 6 device types, is \$8,750.

3. Review of OCP (Phase II) Performance Data

At the Sector's August 2005 meeting, it was agreed that comparative OCP data identifying the Official Meter and listing the average bias for each NTEP meter type should be available for annual review by the Sector. Accordingly, Ms. Brenner, GIPSA, the NTEP Participating Laboratory for Grain Analyzers will present data showing the performance of NTEP meters compared to the air oven. This data is based on the last three crop years (2010 - 2012) using calibrations updated for use during the 2013 harvest season. The 2010-2012 Grain Moisture Meter (GMM) Phase II comparison graphs are available for view or can be downloaded for printing at the following web address:

http://www.ncwm.net/resources/dyn/files/1081743z9820e9b2/_fn/GMMBiases13.pdf

Ms. Brenner reported that on May 1, 2013, the USDA GIPSA official moisture meter for all fifteen NTEP grains switched to the Unified Grain Moisture Algorithm (UGMA) technology. The "Official Meter" designation in the above comparison charts is the UGMA master system which has three years worth of data. The UGMA models, Perten AM 5200-A and Dickey-john GAC 2500 Unified Grain Moisture Algorithm (UGMA) meters do not have three years data. A randomized assignment of codes was used for the individual manufacturers based on the grain groupings with data for the individual manufacturers, so the code identified as "Meter 1" on the charts represents a the same manufacturer on each chart; "Meter A" is a different manufacturer on each chart, etc.

The overall performance of the meters looked good for most grains with the exception of Long Grain Rice, which had the most variation between the official meter and other meters in the program.

4. Amend Table S.2.5. of §5.56.(a) in NIST Handbook 44 - Update

Source:

NTETC Grain Analyzer Sector

Purpose:

Delete "remotely" from the second paragraph of Category 3 requirements that begins, "When accessed remotely ..." to make it clear that the requirements of Category 3 apply whether accessed manually using the keyboard or accessed by remote means, and add the modified second paragraph of Category 3 requirements to Categories 3a and 3b to make it clear that these requirements apply to all the subcategories of Category 3. At the 2013 Annual

Meeting, S&T Item 356-1, amendments to Table S.2.5. of Section 5.56.(a) in NIST Handbook 44 as noted in the item under consideration below, were adopted.

Item Under Consideration:

Table S.2.5. Categories of Device and Methods of Sealing	
Categories of Device	Methods of Sealing
<p>Category 1: No remote configuration capability.</p>	<p>Seal by physical seal or two event counters: one for calibration parameters (000 to 999) and one for configuration parameters (000 to 999). If equipped with event counters, the device must be capable of displaying, or printing through the device or through another on-site device, the contents of the counters.</p>
<p>Category 2: Remote configuration capability, but access is controlled by physical hardware.</p> <p>A device shall clearly indicate that it is in the remote configuration mode and shall not be capable of operating in the measure mode while enabled for remote configuration.</p>	<p>The hardware enabling access for remote communication must be at the device and sealed using a physical seal or two event counters: one for calibration parameters (000 to 999) and one for configuration parameters (000 to 999). If equipped with event counters, the device must be capable of displaying, or printing through the device or through another on-site device, the contents of the counters.</p>
<p>Category 3: Remote configuration capability access may be unlimited or controlled through a software switch (e.g., password).</p> <p>When accessed remotely for the purpose of modifying sealable parameters, the device shall clearly indicate that it is in the configuration mode and shall not be capable of operating in the measuring mode.</p>	<p>An event logger is required in the device; it must include an event counter (000 to 999), the parameter ID, the date and time of the change, and the new value of the parameter (for calibration changes consisting of multiple constants, the calibration version number may be used rather than the calibration constants). A printed copy of the information must be available through the device or through another on-site device. The event logger shall have a capacity to retain records equal to twenty-five (25) times the number of sealable parameters in the device, but not more than 1000 records are required. (Note: Does not require 1000 changes to be stored for each parameter.)</p>
<p>Category 3a: No remote capability, but operator is able to make changes that affect the metrological integrity of the device (e.g., slope, bias, etc.) in normal operation.</p> <p><u>When accessed for the purpose of modifying sealable parameters, the device shall clearly indicate that it is in the configuration mode and shall not be capable of operating in the measuring mode.</u></p>	<p>Same as Category 3</p>
<p>Category 3b: No remote capability, but access to metrological parameters is controlled through a software switch (e.g., password).</p> <p><u>When accessed for the purpose of modifying sealable parameters, the device shall clearly indicate that it is in the configuration mode and shall not be capable of operating in the measuring mode.</u></p>	<p>Same as Category 3</p>

[Nonretroactive as of January 1, 1999 and January 1, 201X
(Amended 1998 and 201X)

Note: Zero-setting and test point adjustments are considered to affect metrological characteristics and must be sealed.

(Added 1993) (Amended 1995 and 1997)

Background/Discussion:

All of the GMMs in Categories 3, 3(a), and 3(c) of Table S.2.5. use an electronic method of sealing, and most of them also offer access to the configuration mode through a keyboard entered password. In this mode, sealable parameters can also be changed locally through the keyboard. Category 3 of Table S.2.5. currently includes the following requirement:

When accessed remotely for the purpose of modifying sealable parameters, the device shall clearly indicate that it is in the configuration mode and shall not be capable of operating in the measuring mode.

At its 2011 Grain Analyzer Sector Meeting, the Sector agreed by consensus that the following changes to Table S.2.5. of Section 5.56.(a) of NIST Handbook 44 should be forwarded to the S&T Committee for consideration:

- Add a note to Table S.2.5. to recognize the expanded scope of “remote capability”.
- Delete “remotely” from the second paragraph of Category 3 requirements that begins, “When accessed remotely ...” to make it clear that the requirements of Category 3 apply whether accessed manually using the keyboard or accessed by remote means.
- Add the modified second paragraph of Category 3 requirements to Categories 3a and 3b to make it clear that these requirements apply to all the subcategories of Category 3.

At the suggestion of National Institute of Standards Technology (NIST), Office of Weights and Measures (OWM), the Table S.2.5. changes approved by the Sector in 2011 have been separated into two independent items: one dealing with the changes to Category 3 and its subcategories (as shown in Item Under Consideration) and one dealing with the modification of the definition of remote configuration capability appearing in Appendix D of NIST Handbook 44 to recognize the expanded scope of “remote capability.” This independence insures that one item will not hold up the other from consideration.

At the 2013 Annual Meeting, S&T Item 356-1, amendments to Table S.2.5. of Section 5.56.(a) in NIST Handbook 44 as noted in the item under consideration above, were adopted. With the adoption of the amendments to Table S.2.5. the following related changes will be made to both the GMM Chapter and the Near Infrared (NIR) Grain Analyzer Chapter of NCWM Publication 14. These changes are shown in Items 4(a), 4(b), and 4(c) following:

4.a. Proposed Changes to Table S.2.5. in Appendix C of the GMM Chapter of Publication 14

Table S.2.5. Categories of Device and Methods of Sealing

Table S.2.5. Categories of Device and Methods of Sealing	
Categories of Device	Method of Sealing
Category 1: No remote configuration capability.	Seal by physical seal or two event counters: one for calibration parameters (000 to 999) and one for configuration parameters (000 to 999.) If equipped with event counters, the device must be capable of displaying, or printing through the device or through another on-site device, the contents of the counters.

**Table S.2.5.
Categories of Device and Methods of Sealing**

Categories of Device	Method of Sealing
<p>Category 2: Remote configuration capability, but access is controlled by physical hardware.</p> <p>Device shall clearly indicate that it is in the remote configuration mode and shall not be capable of operating in the measure mode while enabled for remote configuration.</p>	<p>The hardware enabling access for remote communication must be at the device and sealed using a physical seal or two event counters; one for calibration parameters (000 to 999) and one for configuration parameters (000 to 999.) If equipped with event counters, the device must be capable of displaying, or printing through the device or through another on-site device, the contents of the counters.</p>
<p>Category 3: Remote configuration capability, access may be unlimited or controlled through a software switch (e.g. password).</p> <p>When accessed remotely for the purpose of modifying sealable parameters, the device shall clearly indicate that it is in the configuration mode and shall not be capable of operating in the measure mode.</p>	<p>An event logger is required in the device; it must include an event counter (000 to 999), the parameter ID, the date and time of the change and the new value of the parameter (for calibration changes consisting of multiple constants, the calibration version number may be used rather than the calibration constants.) A printed copy of the information must be available through the device or through another on-site device. The event logger shall have a capacity to retain records equal to twenty-five (25) times the number of sealable parameters in the device, but not more than 1000 records are required. (Note: Does not require 1000 changes to be stored for each parameter.)</p>
<p>Category 3a: No remote capability, but operator is able to make changes that affect the metrological integrity of the device (e.g. slope, bias, etc.) in normal operation.</p> <p><u>When accessed for the purpose of modifying sealable parameters, the device shall clearly indicate that it is in the configuration mode and shall not be capable of operating in the measure mode.</u></p>	<p>Device shall clearly indicate that it is in the remote configuration mode and shall not be capable of operating in the measure mode while enabled for remote configuration.</p>
<p>Category 3b: No remote capability, but access to metrological parameters is controlled through a software switch (e.g. password).</p> <p><u>When accessed for the purpose of modifying sealable parameters, the device shall clearly indicate that it is in the configuration mode and shall not be capable of operating in the measure mode.</u></p>	<p>Remote configuration capability, access may be unlimited or controlled through a software switch (e.g. password).</p>

Non-retroactive as of January 1, 1999. Amended 1998 and 201X

4.b. Proposed Changes to the Checklist of the GMM Chapter of Publication 14

For Category 3 Devices

- 4.6.36. If a measurement is in process when the device is accessed ~~remotely~~ for the purpose of modifying sealable parameters, the measurement is either: Yes No N/A
- Terminated Before Results can be Displayed or Printed **OR**
 - Completed Before Entering the Configuration Mode
- 4.6.37. When accessed ~~remotely~~ for the purpose of modifying sealable parameters, the device clearly indicates that it is in the configuration mode and is not capable of operating in the measure mode. Yes No N/A
- 4.6.37.1 Describe the method used to seal the device or access the audit trail information:

4.c. Proposed Changes to the Checklist of the NIR Grain Analyzer Chapter of Publication 14

Near Infrared (NIR) Grain Analyzers use an electronic method of sealing similar to those of GMMs, and most of them also offer access to the configuration mode thorough a keyboard entered password. In this mode, sealable parameters can be changed locally through the keyboard. At the 2011 NTETC Grain Analyzer Sector Meeting, the Sector agreed that contingent upon acceptance of Item Under Consideration the NIR Check List of NCWM Publication 14 should be modified to delete “remotely” from Section 4 Design of NIR Analyzers, paragraph 4.9.16 as shown below.

- 4.9.16. If a measurement is in process when the device is accessed ~~remotely~~ for the purpose of modifying sealable parameters, the measurement is either:
- 4.9.16.1 Terminated before results can be displayed or printed. **OR** Yes No N/A
- 4.9.16.2 Completed before entering the configuration mode Yes No N/A
- 4.9.16.3 Describe the method used to seal the device or access the audit trail information:

Conclusion:

This item was included on the Grain Analyzer Sector’s 2013 Agenda as an update on the amendments to Table S.2.5. Categories of Device and Methods of Sealing in NIST Handbook 44, Grain Moisture Meter Code Section 5.56.(a) that were adopted at the July 2013 NCWM Annual Meeting. The Sector was in agreement with the changes that were adopted at the July 2013 NCWM Annual Meeting and by consensus agreed to the subsequent changes to Publication 14.

5. Item 356-1 Printed Ticket User Requirements – Update

Source:

Grain and Feed Association of Illinois (2012)

Purpose:

Change the mandatory printing of tickets from grain moisture meters to an “on demand at the time of transaction” printing and remove the requirement of printing the calibration version identification. Note that the S&T Committee did not agree with proposed removal of the requirement to print the calibration version identification; this position is

reflected in the version of the proposal currently under consideration by the Committee. This item was adopted at the 2013 NCWM Annual Meeting.

Item Under Consideration:

Amend NIST Handbook 44, Grain Moisture Meter Code 5.56.(a) as follows:

UR.3.4. Printed Tickets.

- (b) The customer shall be given a printed ticket at the time of the transaction or as otherwise specified by the customer. The printed ticket shall include the date, grain type, grain moisture results, and test weight per bushel, and calibration version identification. The ticket information shall be generated by the grain moisture meter system.

(Amended 1993, 1995, ~~and~~ 2003, and 2013)

Background:

According to the submitter, the user requirement to provide a printed ticket for every single load is unrealistic in the country elevator industry. Traffic patterns at country elevators do not lend themselves to providing a printed ticket to all customers and customers really don't want them. As the speed and capacity increases in the industry, outbound scales are being located at a distance from the inbound scale and the scale house where the moisture tester is located to alleviate traffic bottlenecks. When the outbound scale is located away from where the ticket is printed, the truck driver must circle back around to pick up the ticket, thus, causing logistical problems. In addition, since meters are sealed, inspected and required to have the correct calibration, there is no need for the calibration version identification to be printed on the ticket. Also, most customers are not going to know if it is the correct calibration version identification or not. There have been problems getting the information from the grain moisture meter to the grain accounting system – especially the calibration version identification. Some grain accounting systems have to be “hard coded” for calibration version identification which must be changed whenever the calibration changes. The change will be at an added cost for the industry.

When a consumer pays at a gas pump, they have the option of a receipt on demand at the time of transaction or not receiving a receipt. There would be a cost savings to moisture meter users as they would save on paper and filing space, and in the situation where the calibration version identification is “hard coded,” there will be a cost savings of the expense to have the grain accounting software provider make those changes.

Since moisture meters are capable of printing the ticket, some would argue that they should just go ahead and print them and provide them to the customer. In addition, the requirement does not say when the ticket shall be given to the customer; thus, the printed tickets could be saved for weeks, months, or even years in case the customer had a concern at some point. Printing the calibration version identification ensures the correct calibration is being used.

The submitter proposed amendments to paragraph UR.3.4. Printed Tickets as follows:

UR.3.4. Printed Tickets.

- (b) The customer shall be given a printed ticket on demand at the time of the transaction showing the date, grain type, grain moisture results, and test weight per bushel, ~~and calibration version identification~~. The ticket information shall be generated by the grain moisture meter system.

(Amended 1993, 1995, ~~and~~ 2003, and 20XX)

Central Weights and Measures Association (CWMA) 2011 Interim Meeting: Some jurisdictions opposed the proposal citing that it is a fundamental element of a point of sale transaction that there is either a witness to the transaction or that a receipt is made available. Others supported the item and recognized that many customers refuse to take the printed tickets. The CWMA believes that the calibration version identification is not necessary on the ticket since most jurisdictions are already verifying the calibrations version when the device is inspected. This proposal is not eliminating the opportunity for the seller to obtain a printed ticket. The CWMA forwarded the item to NCWM, recommending it as a Voting Item.

Western Weights and Measures Association (WWMA) 2011 Annual Meeting: The committee heard no comments on this item. The WWMA amended the proposal to make the language consistent with other codes such as 3.32. LPG and Anhydrous Ammonia Liquid-Measuring Devices Code paragraph UR.2.6. Ticket Printer: Customer Tickets. The WWMA forwarded the modified version below to NCWM, recommending it as a Voting Item.

UR.3.4. Printed Tickets.

- (b) The customer shall be given a printed ticket **showing at the time of the transaction or as otherwise specified by the customer. The printed ticket shall include** the date, grain type, grain moisture results, and test weight per bushel, ~~and calibration version identification~~. The ticket **information** shall be generated by the grain moisture meter system.

(Amended 1993, 1995, ~~and~~ 2003, and 20XX)

Northeastern Weights and Measures Association (NEWMA) 2011 Interim Meeting: There were no comments. Deferring to the expertise of the NTETC Grain Analyzer Sector, NEWMA forwarded the item to NCWM, recommending it as a Developing Item.

Southern Weights and Measures Association (SWMA) 2011 Annual Meeting: Ms. Tina Butcher, NIST Technical Advisor, noted that the proposed language submitted was slightly different from that discussed by the NTETC Grain Analyzer Sector and provided a summary corresponding to this item prepared by Ms. Diane Lee, Grain Analyzer Sector Technical Advisor. Ms. Butcher also pointed out that WWMA proposed alternate language that is consistent with printed tickets requirements in other codes. The SWMA agreed that the customer should be given the option of receiving a printed ticket from a transaction and that the proposed changes would clarify the responsibility of the device user. The SWMA preferred the option forwarded by WWMA since it mirrors existing language in other NIST Handbook 44 codes. The SWMA forwarded the item to NCWM, recommending it as a Voting Item as revised by WWMA.

NCWM 2012 Interim Meeting: The S&T Committee received comments in support of the alternative language submitted by the WWMA. NIST, OWM reported that the proposed language submitted to the regional weights and measures associations was different from that agreed to by the Grain Analyzer Sector at its August 2011 meeting. The Grain Analyzer Sector had specifically opposed deleting the phrase “calibration version identification.” NIST, OWM also noted that not all grain moisture meters are Category 3 devices; consequently, calibration version identification information is a critical component on the printed receipt to reconstruct the basis for a sale and help officials to resolve complaints.

The Committee agreed that the version proposed by WWMA and SWMA was preferable since it mirrors similar language in other NIST Handbook 44 codes. The Committee also agreed that, given the Grain Analyzer Sector’s opposition to deleting the reference to “calibration version identification,” this phrase should be retained in the paragraph. The Committee presented an amended version of the proposal. The Committee recognized that the regional associations were not aware of the Sector’s position on the proposed deletion of the reference to the calibration version and that the submitter has not had an opportunity to review the significant changes from the original version. The 2012 S&T Committee designated this item as an Informational Item to allow additional opportunity for input.

At the Sector’s August 2012 meeting, one member suggested that the phrase “or as otherwise specified by the customer” be modified to read “or as agreed to by the customer.” Customers are not going to proactively specify how elevator record keeping systems are put together, but they can agree that this information comes on a settlement sheet. A contract for the sale of grain at some future date with XYZ Grain contains a phrase that the seller agrees to XYZ Grain’s various transaction policies. By signing the contract, the seller agrees to accept settlement sheet information via a web listing that can be accessed with a computer or possibly using a smart phone. The seller is not “specifying” how he wants to receive the “ticket” information, he is just “agreeing” to receive it in a different manner.

The wording proposed by the Sector in 2011, “A printed ticket shall be made available to the customer upon request at the time of transaction...” did not require the customer to do anything if he didn’t want a ticket, but it did require

him to ask for one if he wanted one. The wording in the Item Under Consideration required the customer to say, “I don’t want a ticket ...” if a ticket wasn’t wanted. If he said nothing, he would be given a ticket (or offered one).

Other Sector members felt that the wording of the Item Under Consideration allowed flexibility, and most were in favor of accepting the Item Under Consideration. An attempt to obtain a consensus on the S&T Committee’s proposal was unsuccessful due to one jurisdiction’s belief that ...”a ticket is given to the customer no matter what.”

There was further discussion on whether the wording in the Item Under Consideration, “... at the time of the transaction or as otherwise specified by the customer” means that the customer gets a ticket at the time of transaction or at a later specified time. Some believed that “as otherwise specified by the customer” could mean “never” or “in another form.” Sector Chairman, Ms. Cassie Eigenmann, DICKEY-john, Corp., reminded the Sector that the reason Illinois Grain & Feed Association submitted the request for change was because they did not want to have to print a ticket at the time of transaction unless the customer requested one at the time of transaction.

It was pointed out that unless a ticket is printed by the GMM before the grain sample is “dumped” from the GMM it may not be possible for the GMM to print a ticket for that transaction. The information, however, could reside in the memory of the elevator’s grain transaction system and could be printed in another form for example, on a settlement sheet that is sent (or transmitted) to the seller later. Further discussion suggested that the S&T proposed wording could be interpreted to mean that elevators that captured GMM information in their grain transaction system at the time of transaction would not have to supply a GMM printed ticket at time of transaction unless requested by the customer at time of transaction. If the elevator is using a GMM that is equipped to record and that was put into service **before** January 1, 1998, the elevator would be required to give the customer a printed ticket at the time of transaction (need print only percent moisture content and grain selected).

Grain Analyzer Sector 2012 meeting: The Sector agreed in a vote of nine in favor and one opposed to the Item Under Consideration.

WWMA received no comments on this item at its 2012 Annual Meeting. The WWMA believed the intent in the amended proposed language is similar to other codes in HB 44 and sufficiently gives options of how printed tickets are provided to the customer. WWMA supported the item and recommended that it be a Voting Item.

NEWMA supported this item as a “Voting” item at both its 2012 Interim Meeting and 2013 Annual Meeting.

The SWMA received no comments at its 2012 Annual Meeting. The Committee recognized that the NCWM S&T Committee designated this as an Informational item to allow additional time for the weights and measures community, including the original submitter to review the changes made to the proposal during the 2012 NCWM Interim Meeting. The Committee believes that adequate time has elapsed to allow for comment. The Committee noted that the NTEP Grain Sectors have also reviewed the proposal, as modified, and have expressed no opposition. SWMA recommended that the item be a Voting item.

During its Open Hearings at the 2013 NCWM Interim Meeting, the Committee heard comments from Ms. Juana Williams (NIST, OWM) who noted that OWM believes the suggested changes to UR.3.4. Printed Tickets are appropriate and notes that the language is similar to other codes in NIST Handbook 44. OWM agrees with the Grain Analyzer Sector’s decision to retain the requirement for recording the “calibration version identification.” OWM notes that while “Category 3” devices would require the printing of the calibration version identification information, not all grain moisture meters are “Category 3” devices. Having this information printed on receipts provides customers and officials with the means to verify that correct calibration settings are being used for a given transaction. The Committee received no other comments on this item. Hearing no opposition to the proposed changes, the Committee agreed to recommend the proposal for a vote.

NCWM 2013 Online Position Forum: One Government representative opposed the proposal, with no additional comments. During Open Hearings at the 2013 NCWM Annual Meeting, the Committee heard no comments in opposition to this item. NIST, OWM reiterated its comments from the 2013 Interim Meeting. The Item Under Consideration was adopted at the 2013 NCWM Annual Meeting.

Conclusion:

This item was included on the Grain Analyzer Sector’s 2013 Agenda as an update on the amendments to UR.3.4. Printed Tickets in NIST Handbook 44, Grain Moisture Meter Code 5.56.(a) that were adopted at the July 2013 NCWM Annual Meeting. The Sector was in agreement with the changes that were adopted at the July 2013 NCWM Annual Meeting.

6. Modify the Definition of Remote Configuration Capability Appearing in Appendix D of NIST Handbook 44 to Recognize the Expanded Scope of “Remote Configuration Capability” (S&T Developing Item 360-7)

Source:

NTETC Grain Analyzer Sector

Purpose:

Table S.2.5. *Categories of Device and Methods of Sealing* that appears in Section 5.56.(a) of NIST Handbook 44 lists acceptable methods of sealing for various categories of GMMs. When the Sector first recommended adding the table to NIST Handbook 44 at their September 1996 meeting, the concept of making a change to a GMM from a remote site involved information “...sent by to the device by modem (or computer).” In 2011 this concept has expanded to include the ability of the measuring device to accept new or revised sealable parameters from a memory chip (e.g., an SD Memory Card that may or may not itself be necessary to the operation of the device), external computer, network, or other device plugged into a mating port (e.g., Universal Serial Bus (USB) port) on the measuring device or connected wirelessly to the measuring device. The changes proposed in Item Under Consideration expand the scope of “remote configuration capability” to cover instances where the “other device” may be necessary to the operation of the weighing or measuring device or which may be considered a permanent part of that device.

Item Under Consideration:

remote configuration capability. – The ability to adjust a weighing or measuring device or change its sealable parameters from or through some other device that ~~is not~~ **may or may not** itself **be** necessary to the operation of the weighing or measuring device or ~~is not~~ **may or may not be** a permanent part of that device. [2.20, 2.21, 2.24, 3.30, 3.37, 5.56(a)]

(Added 1993, **Amended 20XX**)

Background/Discussion:

Two common types of removable data storage devices are the USB flash drive and the Secure Digital (SD) memory card. A USB flash drive is a data storage device that includes flash memory with an integrated USB interface. USB flash drives are typically removable and rewritable, and physically much smaller than a floppy disk. A SD card is a non-volatile memory card format originally designed for use in portable devices. The SD standard is maintained by the SD Card Association.

Removable digital storage devices can be used in GMMs as either “data transfer” devices which are not necessary to the operation of the GMM or as “data storage devices” which are necessary to the operation of the GMM.

A USB flash drive is most likely to be used as a “data transfer” device. In a typical “data transfer” application, the USB flash drive is first connected to a computer with access to the web. The computer visits the GMM manufacturer’s web site and downloads the latest grain calibrations that are then stored in the USB flash drive. The USB flash drive is removed from the computer and plugged into a USB port on the GMM. The GMM is put into “remote configuration” mode to copy the new grain calibration data into the GMM’s internal memory. When the GMM has been returned to normal operating (measuring) mode the USB flash drive can be removed from the GMM.

Although an SD memory card could also be used as a “data transfer device,” it is more likely to be used as a “data storage device.” In a typical “data storage device” application, the SD memory card stores the grain calibrations used on the GMM. The SD memory card must be plugged into an SD memory card connector on a GMM circuit

card for the GMM to operate in measuring mode. To install new grain calibrations the GMM must be turned “off” or put into a mode in which the SD memory card can be safely removed. The SD memory card can either be replaced with an SD memory card that has been programmed with the new grain calibrations or the original SD memory card can be re-programmed with the new grain calibrations in much the same way as that described in the preceding paragraph to copy new grain calibrations into a USB flash drive. In either case, the SD memory card containing the new calibrations must be installed in the GMM for the GMM to operate in measuring mode. In that regard, the SD memory card) can be considered a “permanent part” of the GMM in that the GMM cannot operate without it.

Note: In the above example “SD memory card” could be any removable flash memory card such as the Secure Digital Standard-Capacity, the Secure Digital High-Capacity, the Secure Digital eXtended-Capacity, and the Secure Digital Input/Output, which combines input/output functions with data storage. These come in three form factors: the original size, the “mini” size, and the “micro” size. “Memory Stick” is a removable flash memory card format, launched by Sony in 1998, and is also used in general to describe the whole family of Memory Sticks. In addition to the original Memory Stick, this family includes the Memory Stick PRO, the Memory Stick Duo, the Memory Stick PRO Duo, the Memory Stick Micro, and the Memory Stick PRO-HG.

At its 2012 meeting, the Grain Analyzer Sector agreed by consensus to accept the Item Under Consideration and recommended forwarding this item to the S&T Committee for consideration.

WWMA 2012 Annual Meeting: Ms. Juana Williams (NIST, OWM) supported the intent. She talked about this item in conjunction with Item 356-1, S.2.5. Categories of Device and Methods of Sealing. This is a complex item affecting multiple other devices; therefore the proposal requires further consideration. The language in the proposal to amend the definition of remote configuration capability is confusing. The Committee believes the current definition already allows the use of remote configuration devices and allows the flexibility desired. The ramifications of changing the definition could affect other devices in NIST Handbook 44. WWMA did not forward this item to NCWM.

SWMA 2012 Annual Meeting: There were no comments. After reviewing the proposal and considering the potential impact on other device types, the Committee recommended this as a Developing Item. The Committee asks that the Sector continue to obtain input on the definition and the impact the changes would have on other device types. SWMA forwarded the item to NCWM, recommending it as a Developing Item and assigning its development to the Grain Analyzer Sector.

During its Open Hearings at the 2013 NCWM Interim Meeting, the Committee heard comments from Ms. Williams (NIST, OWM). OWM suggests the Committee consider this item as a Developing item to allow other Sectors to discuss how a change to the definition may affect other device types of similar design and to consider changes if needed. OWM recognizes that the current definition for “remote configuration capability” may not address those grain moisture meters (GMMs) which can only be operated with a removable data storage device, containing, among other things, the grain calibrations intended for use with the GMM, inserted in the device (as was described by the Grain Analyzer Sector). As such, OWM notes that current sealing requirements were developed at a time when such technology likely didn’t exist, nor could be envisioned, and are based on the current definition of remote configuration capability. Because the current definition was never intended to apply to this “next generation” technology, OWM suggests that those charged with further development of this item may wish to revisit the five philosophies of sealing and consider whether a new paragraph, completely separate from current sealing requirements, might be appropriate and a better option, than the one currently proposed. The five philosophies of sealing are included in the 1992 *Report of the 77th National Conference on Weights and Measures* (Report of the Specifications and Tolerances Committee). Another option, preferred over the changes currently proposed, would be to add a separate statement to the current definition of “remote configuration capability” to address removable storage devices. For example, the following sentence might be considered as an addition to the current definition for “remote configuration capability:”

Devices which are programmed using removable media (such as SD cards, flash drives, etc.) that may or may not be required to remain with the device during normal operation are also considered to be remotely configured devices.

The Committee also heard comments from Dmitri Karimov (LC), speaking on behalf of the MMA, who made two points: (1) flow computers may already have these capabilities, thus it may be more appropriate to consider adding requirements to the General Code so that the requirements will be uniformly applied to all device types; and (2) the Committee should look ahead and consider other capabilities that may or already have emerged such as wireless communication and configuration.

The Committee acknowledged the comments indicating that the current definition of “remote configuration capability” was developed at a time when certain technologies, such as blue tooth, SD storage devices, flash drives, etc., didn’t exist. The Committee recognized that it may be difficult to modify the existing definition and associated requirements to be flexible enough to address emerging and future technologies without having a significant (and possibly detrimental impact) on existing devices. Consequently, rather than modifying the current definition, the Committee concluded that a better approach might be to develop an entirely separate set of security requirements that would apply to emerging technologies. The Committee believes that additional work is needed to develop proposed definition(s) and associated requirements and decided to designate the item as Developmental. The Committee requests other Sectors review the Grain Sector’s proposed modification to the definition as well as OWM’s suggestions and provide input.

At their 2013 Annual Meetings, both NEWMA and CWMA supported this as a Developing item. NEWMA heard from NIST who encouraged members to consider this work as it applies to all device types.

On the 2013 NCWM Online Position Forum, one Government representative indicated a neutral position on this item with no additional comments.

NCWM 2013 Annual Meeting Open Hearings: The Committee heard comments from Ms. Williams (NIST, OWM) who reiterated OWM’s comments from the 2013 Interim Meeting, suggesting that it may be appropriate to develop separate requirements to address new and future technologies which can be remotely configured with removable media. OWM plans to develop draft language and ask for input from the various Sectors at their upcoming meetings. Ms. Williams also noted the suggestion made at the 2013 NCWM Interim Meeting by Mr. Dmitri Karimov, LC, speaking on behalf of the MMA, that a provision might be added to the General Code to address this type of equipment.

Ms. Julie Quinn (Minnesota) agreed with OWM’s comments and indicated support for possibly including requirements in the General Code to address newer and emerging technologies. Mr. Karimov (LC), speaking on behalf of MMA, concurred with this suggestion.

The Sector is asked to review and discuss the proposed language, and propose any additional language for changes to the definition of remote configuration capability.

Conclusion:

At the time of the August 2013 Grain Analyzer Sector Meeting, OWM had not drafted a definition for remote configuration capability to address devices which are programmed using removable media such as SD cards or flash drives. During the August 2013 Grain Analyzer Sector Meeting, the Sector discussed other ways devices can be remotely configured that should also be considered when drafting a definition for remote configuration capability to address these devices.

Mr. Hurburgh mentioned that we also need to consider devices that use cloud computing to remotely configure a device and suggested that we consider the various ways a device can be remotely configured.

The Sector agreed that OWM should develop a proposal for a definition for remote configuration capability that addresses devices that use removable media such as SD cards, flash drives or other methods not covered by the existing definition.

7. Status of Interagency Agreement and Impact of UGMA (new GIPSA designated) Meter on Another 5-year Agreement

Source:

Cathy Brenner, USDA, GIPSA

Background/Discussion:

The current Interagency Agreement is the fourth 5-year agreement of the on-going calibration program. The agreement was signed in March 2010 and runs through analysis of the 2014 crop and issuance of the 2015 Certificates of Conformance (CC). Thus, we have just started the fourth year of the current agreement. It should be noted that annual calibration activities occur in two government fiscal years and are better defined by a starting date of July 1. The current 5-year agreement 2010 - 2014 is included in the table below:

Proposed NTEP On-going Calibration Program Fee Schedule For Year 2010 to 2014							
(1) Total Meters (including official meter)	(2) Meters In NTEP Pool	(3) Cost Per Pool Meter	(4) Total Program Cost	Funding Contribution From Participants			
				(5) NIST	(6) GIPSA	(7) Mfg's (total funding from mfg's)	(8) Cost Per Meter Type
2	1	22,500	22,500	7,500	7,500	7,500	3,750
3	2	22,500	45,000	15,000	15,000	15,000	5,000
4	3	22,500	67,500	22,500	22,500	22,500	5,625
5	4	22,500	90,000	30,000	30,000	30,000	6,000
6	5	22,500	112,500	30,000	30,000	52,500	8,750
7	6	22,500	135,000	30,000	30,000	75,000	10,715
8	7	22,500	157,500	30,000	30,000	97,500	12,185
9	8	22,500	180,000	30,000	30,000	120,000	13,335

Explanation of columns in the Fee Schedule table:

<u>Column</u>	<u>Explanation (or formula for calculating)</u>
(1) Total Meters	The number of meter types (including the Official GIPSA meter) that will share in the NTEP calibration costs.
(2) Total Meters in NTEP Pool	The number of meter types other than the Official meter that will share in the NTEP calibration costs.
(3) Cost per Pool Meter	The cost associated with each pool meter in the program.
(4) Total Program Cost	A per meter type cost of \$22,500 times the number of NTEP "pool" meters.
(5) NIST Contribution	One-third the total program cost up to a maximum of \$30,000.
(6) GIPSA Contribution	One-third the total program cost up to a maximum of \$30,000.
(7) Manufacturers Contributions (total funding from manufacturers)	Total Program Cost minus NIST Contribution minus GIPSA Contribution.
(8) Cost per Meter Type	Manufacturers' Contributions divided by Total Meters (including the official meter).

The GIPSA Technology and Science Division is currently seeking, and expects to obtain, agency support for another Interagency Agreement. Challenges include a continuing government-wide emphasis on fee supported programs. We would like to complete GIPSA discussion this fall and draft a proposal for NIST consideration next spring.

Program costs are difficult to project. GIPSA recently evaluated its fee structure for evaluation testing and is in the process of evaluating fee structures for the commodity program (currently used for reference lab fees). The fee structure has a built in annual fee increase and there is discussion of building in annual fee increases for the commodity program as well. Listed below is the evaluation testing fee structure as published in the Federal Register, <http://www.gipsa.usda.gov/Federal%20Register/fr13/04-15-2013a.pdf> , for May 2013 through Fiscal Year 2017.

<u>Effective Date</u>	<u>Hourly Rate</u>
May 1, 2013	\$87.40
October 1, 2013	\$89.20
October 1, 2014	\$91.00
October 1, 2015	\$92.90
October 1, 2016	\$94.80

On May 1, 2013, GIPSA completed the transition from the Dickey-john GAC2100 to the GIPSA UGMA master system using the Dickey-john GAC2500-UGMA and the Perten AM5200-A as the official moisture meters. GIPSA is in the early stages of determining how the program to maintain the official inspection system moisture calibrations may change due to the implementation of the UGMA technology for official moisture determinations. The NTEP Phase II, On-going Calibration Program, is built on top of the official moisture calibration program. TSD believes that the on-going calibration program has been very successful in meeting standardization goals and is working to keep fee increases at a reasonable level as it is extremely unlikely that either NIST or GIPSA will be able to increase their support beyond the current maximum of \$30,000 per year.

In order to provide the standardization services to the commercial system, GIPSA TSD is currently discussing options for improving the process and reducing the burden on all parties. GIPSA is seeking input from the Sector on limiting the number of samples tested to a maximum of 10 samples per two-percent moisture interval for all grains.

At the August 2013 Grain Analyzer Sector meeting, the Sector discussed limiting the samples tested per two-percent moisture interval in the ongoing calibration program to a minimum to keep any fee increase to a minimum for this testing. It was noted that fewer sample are needed to calibrate the new UGMA meters. It was also noted that GIPSA's fees are increasing and with no changes to the program the manufacturers fees will increase. During the discussion one alternate proposal was to base the cost on one-third shared cost of the program where GIPSA and NIST cover one-third of the cost of the program each and manufacturers split one-third of the cost. It was noted during the meeting that due to budget issues GIPSA and NIST will likely not be able to fund more than the \$30 000 per year.

Conclusion:

Ms. Brenner agreed to review the statistics to determine how the sample size of up to 30 samples per two-percent moisture interval per grain type was established and to investigate the impact of reducing the sample size to 10 sample per two-percent moisture interval per grain type. The Sector agreed by consensus to reduce the number of samples used in the ongoing calibration program for each two-percent moisture range per grain type as long as the integrity of the program is not affected.

8. Near Infrared Corn NTEP Support

Source:

Cathy Brenner, USDA GIPSA

Purpose:

When the NIR Corn constituent ranges listed in NCWM Publication 14 were created, there was a market for high oil corn. That market has changed and GIPSA is not receiving these types of samples which are needed to maintain the sample set criteria currently listed in NCWM Publication 14. In 2012, Iowa State University received some high oil corn samples from a seed company. Iowa State informed the NTEP laboratory that organic breeders are increasing oil in some specialty hybrids. The NTEP laboratory is working with Iowa State to obtain additional samples to try and rebuild its sample library for two complete sets of NIR Corn Accuracy.

Item Under Consideration:

The question for the Sector is whether or not NCWM Publication 14 should be changed to exclude corn or change the oil constituent range in NCWM Publication 14 from the 3 - 9 range at 0 % M.B. to a commodity corn oil constituent range of 3 - 5 range at 0 % M.B. It should also be noted that Publication 14 includes constituent ranges and tolerances for corn starch. The NTEP laboratory has not evaluated any NIR instruments for corn starch due to the difficulties in obtaining the samples that meet the requirements for the accuracy set.

Proposed changes to NCWM Publication 14, Near Infrared:

III. Accuracy, Precision and Reproducibility Requirements

Grain analyzers will be tested for accuracy, repeatability (precision), and reproducibility over the applicable constituent concentration ranges shown in Table 1. Instrument and calibration performance will be individually tested for each grain type and constituent.

Table 1. Constituent Ranges for Type Evaluation

Grain Type	Constituent	Constituent Range (%) at Moisture Basis (M.B.) Shown	Low Moisture Range	High Moisture Range
Durum Wheat	Protein	10 – 18 at 12 % M.B.	10 % – 12 %	13 % – 15 %
Hard Red Spring Wheat	Protein	10 – 19 at 12 % M.B.		
Hard Red Winter Wheat	Protein	8 – 18 at 12 % M.B.		
Hard White Wheat	Protein	9 – 16 at 12 % M.B.		
Soft Red Winter Wheat	Protein	9 – 12 at 12 % M.B.		
Soft White Wheat	Protein	8 – 15 at 12 % M.B.		
All-Class Wheat Calibration*	Protein	8 – 19 at 12 % M.B.		
Wheat Excluding Durum*	Protein	8 – 19 at 12 % M.B.		
Two-rowed Barley	Protein	8 – 17 at 0 % M.B.	10 % – 12 %	13 % – 15 %
Six-rowed Barley	Protein	8 – 17 at 0 % M.B.		
All-Class Barley Calibration*	Protein	8 – 17 at 0 % M.B.		
Corn Or Corn	Protein	8 – 12 at 0 % M.B.	11 % – 13 %	14 % – 16 %
	Oil Or Oil	3 – 9 at 0 % M.B. Or 3 – 5 at 0 % M.B.		
	Starch	67 – 73 at 0 % M.B.		
Soybeans	Protein	30 – 40 at 13 % M.B.	10 % – 12 %	13 % – 15 %
	Oil	16 – 21 at 13 % M.B.		

Note: Calibrations marked with an asterisk () are "Multi-class" calibrations*

Background/Discussion:

The challenge is that Iowa State may not have sufficient samples that are large enough to provide the NTEP laboratory with appropriate amounts of the samples to allow for testing. When testing, the laboratory will consume approximately 150 grams from each sample. Iowa State has also worked with several NIR manufacturers to develop corn calibrations for their instruments and may not have a large number of samples that have not been included in any of these calibrations. Dr. Charles Hurburgh also indicated that the newer high oil hybrids may not be well predicted on the current GIPSA calibration that is used to screen samples for the accuracy set selection.

The Grain Analyzer Sector is asked to consider the proposed change and discuss the proposed changes during the Sector meeting.

At the August 2013 Sector meeting, Ms. Brenner restated her concerns with getting an appropriate sample size to perform the official test for high oil corn and her proposal to reduce the constituent range for corn as shown above. It was noted during the discussion that there is a limited market for high oil corn because of the current market for other oils. It was also noted that business conducted for high oil corn is done on a contractual basis.

Conclusion:

The Sector agreed by consensus to leave the current ranges as listed in NCWM Publication 14 and the type of corn used within the stated range will be supported by statistics.

9. Test Weight per Bushel Acceptance and Maintenance Tolerance

Source:

Mr. Jeffrey D. Adkisson, Grain and Feed Association of Illinois

Purpose:

Due to problems cited in the grain and feed industry, review and make any needed changes to the test weight per bushel tolerances in NIST Handbook 44 Section 5.56.(a).

Item Under Consideration:

During the discussion of this item at the 2012 Sector meeting it was noted that because the system is rapidly changing over to the new UGMA technology which is going to result in the improvement in TW readings, TW should resolve itself as older instruments are retired. It was also mentioned that test weight data is needed to review the current system to make any needed changes to test weight per bushel and that sample selection when testing meters for test weight, should be reviewed. It was recommended that TW per bushel comparison charts be developed for review. Ms. Cathy Brenner developed these charts and the Sector is asked to review these charts for discussion during the meeting. The charts are available for review or can be downloaded for printing at the following web address:

http://www.ncwm.net/resources/dyn/files/1081742zef27d924/_fn/TW+2013+Sector+Meeting.pdf

Background/Discussion:

This is a carryover from the Sector's 2011 meeting. Mr. Adkisson, Grain and Feed Association of Illinois, cited problems his industry is having regarding Test Weight (TW) per bushel. GMMs that have failed TW during field inspection are sent to the manufacturer for repair. When the meters are returned, the reports indicate that no problems have been found. There are also situations where a meter has failed TW. When the state inspector subsequently tested the elevator's quart kettle it matched the meter, but it didn't match the state inspector's sample. This is particularly frustrating for the country elevators in Illinois that are using the GMM TW only as a screening tool.

At the Sector's August 2011 meeting, a task group was formed to investigate the whole TW system with the goal of defining procedures that would improve TW both for the user and for the inspection system. Past data obtained by the Sector had indicated that the existing tolerances were reasonable. It was felt that increasing TW tolerances would only cover up the problems. What was needed was an investigation of the whole system of calibrating meters, then translating that calibration into the field, and then keeping it that way.

Dr. Charles R. Hurburgh, Jr., Iowa State University, agreed to head the task group. Other TW Task Group members included:

- Mr. Jeffery Adkisson – Grain and Feed Association of Illinois
- Ms. Diane Lee – NIST, OWM
- Ms. Cassie Eigenmann – DICKEY-john Corporation
- Mr. Ivan Hankins – Iowa Department of Agriculture/Weights and Measures
- Mr. Tim Kaeding – Perten Instruments, Inc.
- Mr. Karl Cunningham – Illinois Department of Agriculture

Further action on the issue of tolerances was postponed until the TW Task Group was able to recommend appropriate action.

In Early 2012 the TW Task Group developed the following list of Action Items:

- Survey the grain industry as to the frequency of discounting each of the major grains (wheat, corn, and soybeans) for test weight, and within those discounted the frequency of use of the meter test weight versus the cup-bucket test weight.
- Survey the industry for comparative data between meters and an Official GIPSA agency on the same samples.
- Develop a draft procedure for sample selection and pre-qualification.

Dr. Hurburgh reported that discounting for low TW was not an issue in either 2010 or 2011. TWs for corn were so high that discounting was not an issue. Within Iowa most grain elevators were using the TW reported by their GMM. Only a few were using the standard quart kettle method. This is likely to change in the 2012 harvest as low TWs are likely to be more common. Also, there may not be as much TW increase in drying as would normally be expected. TW may come up again as a discount factor.

Same sample TW data has not been collected comparing grain elevator GMMs with an Official GIPSA agency. Dr. Hurburgh explained that this information should be relatively easy to obtain, because in almost every case when a train is officially graded the samples are run at the grain elevator first. Since last year's Sector meeting, the rapid acceptance of the new UGMA GMMs as Official Meters for corn, soybeans, sunflowers, and grain sorghum (with the remaining grains scheduled to switch to UGMA GMMs for Official Inspection on May1, 2013), has altered some of the issues. The new technology not only provides a better moisture measurement, but a better TW measurement as well.

The remaining action item that the task group believed was necessary was a procedure for pre-qualifying TW samples as being good predictors for the TW function as well as moisture function. Most states pre-screen moisture samples to get the outliers out of the system. That pre-qualification would have to be expanded if TW is to be actively used to reject meters on the basis of TW.

Dr. Hurburgh recommended that the Sector not adjust TW tolerances at this time, because the system is rapidly changing over to the new technology which is going to result in the improvement in TW readings. The problem should resolve itself as older instruments are retired.

Mr. Karl Cunningham, Illinois Dept of Agriculture, informed the Sector that Illinois's TW rejection rate has gone down in the last two years. He has no problem with TW on the meters in his laboratory and doesn't think the present tolerances are a problem. Many of the field problems may be due to rough handling of the meters during shipping. Mr. Cunningham advises elevators who have to have their devices worked on to take them to the manufacturer's service department themselves if at all possible.

Mr. Tim Kaeding, Perten Instruments, suggested that there might be value in expanding the Phase II OCP grain moisture comparison charts to include TW. Dr. Hurburgh recommended that a TW comparison chart showing the spread of TW measurements for individual meters against the corresponding official quart kettle TW measurements would address the tolerance issue, whereas a bias plot would not. He suggested plotting meter TWs on the x-axis and quart kettle results on the y-axis. A best-fit line could be drawn for each meter.

The Sector agreed that TW comparison charts should be prepared for the three grains which are most likely to be subject to discounts on the basis of TW: corn and two wheat classes. The wheat classes selected were: Hard Red Winter and Soft Red Winter. Manufacturer approval is required for NTEP Phase II TW performance data to be released for publication even if individual instruments are not identified. The two meter manufacturers present indicated that they would approve the release of this data. Permission would have to be obtained from the other manufacturers. The Sector agreed to postpone further action on changing TW tolerances until more information was available.

At the August 2013 Sector Meeting, Ms. Brenner reviewed test weight per bushel data for Corn, Hard Red Winter Wheat and Soft Red Winter Wheat (See charts below). The data showed that NTEP meters aligned closely with the

official quart kettle test weight per bushel measurements. States noted that they have seen a significant improvement in test weight per bushel measurements and lower complaints have been received concerning test weight. Mr. Karl Hansan stated that he is collecting data on the moisture changes in grain samples over time when using the samples in the field. This data can be used to improve the field inspection of the test weight per bushel measurements on grain analyzers. Ms. Lee, provided a draft copy of a weights and measures newsletter article entitled “Determining Reference Test Weight per Bushel Value of Grains.” Following the August Sector Meeting the article was published in the Weights and Measures newsletter (*Weights and Measures Connection*) and can be accessed at: <http://www.nist.gov/pml/wmd/pubs/upload/WMConnections.pdf>. This article will help to ensure that States are following proper procedures when assigning reference test weight per bushel values to grains used to test instruments that provide test weight per bushel measurements.

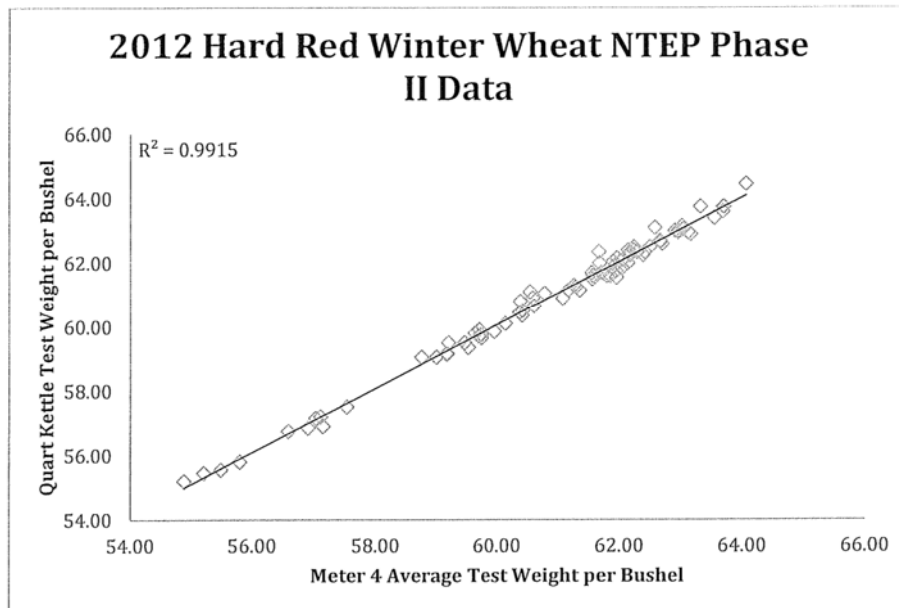
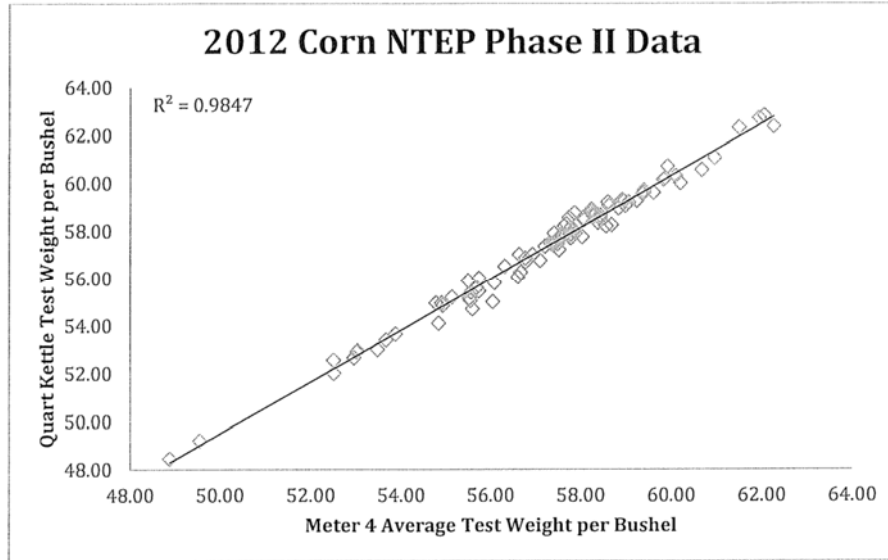

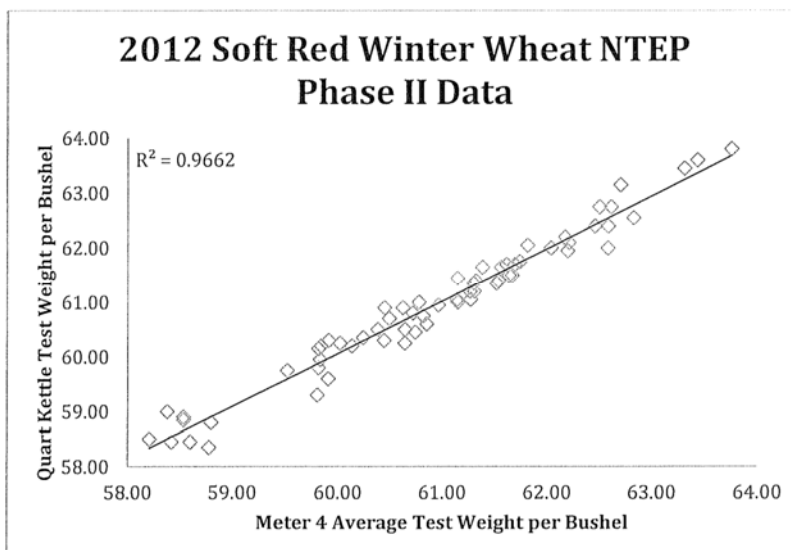

Conclusion:

The Sector agreed to continue to monitor the issue of test weight per bushel and Mr. Hansan agreed to share the field data on the changes in grain samples used in field testing.

10. Report on International Organization of Legal Metrology (OIML) TC 17/SC 1 R 59 Moisture Meters for Cereal Grains and Oilseeds and proposed changes to the NTEP humidity test for grain moisture meters and near infrared grain analyzers

Source:

Cathy Brenner, USDA, GIPSA

Purpose:

Harmonize OIML and NTEP test procedures to align the U.S. humidity test procedures with the OIML D 11 Damp Heat test procedure.

Item Under Consideration:

Replace the current Humidity test in Publication 14 for both moisture and protein with the International OIML D 11 Damp heat test as shown below. If the following changes are approved, then the detailed procedure in Appendix A for Grain Moisture Meters will need to be revised by the NTEP laboratory.

For Grain Moisture Meters –

Damp Heat

Each instrument (power on) will be placed in an environmental chamber at 22 °C and 30 % relative humidity for 16 hours. Three HRW wheat samples, one selected from each of the 2 % moisture intervals, will be placed in the environmental chamber two hours prior to testing. Each sample will be analyzed five times and removed from the chamber. The environmental chamber will be set to the maximum ambient temperature specified by the manufacturer or 45 °C whichever is less and a relative humidity of 50 % but not to exceed the absolute humidity of 20 g/m³ for 16 hours. The samples will be placed in the environmental chamber two hours prior to testing. Each sample will be analyzed five times. A maximum bias shift of 0.18 % of grain moisture content per sample is allowed between the average readings at the lower temperature and those made at the higher temperature.

For Near Infrared Grain Analyzers –

Damp Heat

Each instrument (power on) will be placed in an environmental chamber at 22 °C and 30 % relative humidity for 16 hours. Three HRW wheat samples, one selected to represent the low (10 % to 12 %), medium (12 % to 14 %), and high (14 % to 16 %) protein levels, will be placed in the environmental chamber two hours prior to testing. Each sample will be analyzed five times and removed from the chamber. The environmental chamber will be set to the maximum ambient temperature specified by the manufacturer or 45 °C whichever is less and a relative humidity of 50 % but not to exceed the absolute humidity of 20 g/m³ for 16 hours. The samples will be placed in the environmental chamber two hours prior to testing. Each sample will be analyzed five times. A maximum bias shift of 0.18 % of grain moisture content per sample is allowed between the average readings at the lower temperature and those made at the higher temperature.

Background/Discussion:

This item was included on the Sector's agenda to provide a summary of the activities of OIML TC 17/SC 1 for the Grain Analyzer Sector and to those Sector members that participate on the United States National Working Group (USNWG) on grain moisture meters. In addition the Sector is asked to review a proposal to change the Humidity test in NCWM Publication 14 to align with the OIML D 11 and IEC damp heat test procedure.

OIML TC 17/SC 1 was tasked to revise OIML R 59 *Moisture Meters for Cereal Grains and Oilseeds* to reflect new technologies and actual grain analysis. The Co-Secretariats (China and the United States) are working closely with an International Project Group to revise OIML Recommendation R 59 *Moisture Meters for Cereal Grains and Oilseeds*. The United States completed a six committee draft (6 CD) of OIML R 59, which was circulated to the international project group and the U.S. National Working Group (USNWG) on grain moisture measuring devices for review and comment on March 6, 2013. The U.S. Co-secretariat requested that the comments to the 6 CD be submitted by June 6, 2013. The U.S. Secretariat collated the United States and international comments to the 6 CD and these comments were reviewed at the TC 17/SC 1 meeting hosted by NIST, OWM July 23 - 24, 2013.

At the TC 17/SC 1 July 23 - 24, 2013, meeting, comments to the 6 CD were reviewed and the major discussion was harmonization of test procedures between OIML TC 17/SC 1 R 59 *Moisture Meters for Cereal Grains and Oilseeds* and OIML TC 17/SC 8 Recommendation on *Protein Measuring Instruments for Cereal Grain and Oil Seeds*.

At the July 2013 meeting, it was discussed that the international damp heat test (OIML D 11 and IEC) is significantly different from the NTEP Humidity test. The international test is more robust and more accurately reflects the environmental conditions an instrument is likely to encounter in field use. The damp heat test is conducted at a maximum temperature of either the manufacturer specified upper ambient temperature or 30 °C and a maximum relative humidity of 85 %. The damp heat test is designed to evaluate the device under the environmental (temperature and relative humidity) conditions it will encounter during operation.

At the December 1991 organizational meeting, the NIR Wheat Protein Analyzer Sector reviewed the USDA Federal Grain Inspection Service's (FGIS) Design Criteria and Operational Performance Specifications (DCOPS) for Grain Constituent Measuring Instruments using Near Infrared Spectroscopy dated January 1989. The NTETC NIR Sector recommended that the environmental tests, including humidity, listed in the DCOPS be adopted and that tolerances for some test may need to be re-evaluated. The humidity test was designed to evaluate the affect of humidity on the instrument while holding the temperature constant.

At the March 1992 NTETC Grain Moisture Meter Sector Meeting, the FGIS Moisture Handbook, NIST Handbook 44, and OIML International Recommendation R 59 "Moisture Meters for Cereal Grains and Oilseeds" were reviewed. The Subcommittee discussed that humidity might have considerable affect on the performance of thermogravimetric devices and resistance meters. It was suggested that humidity tests could be adapted from the OIML R 59 Damp heat, steady state test.

The moisture subcommittee met in August 1992 and recommended the humidity test that is currently in NCWM Publication 14 which agrees with the NIR test. At the October 1992 NTETC grain moisture meter Sector meeting, the Sector approved the recommendations made by the subcommittee for the humidity test.

Since 1994, no device has failed the humidity test for either moisture or protein.

The proposed damp heat test for the OIML Protein document specifies the test as shown below. At the July 2013 meeting, it was agreed to review the number of replicates used for the test. The number of replicates per sample being considered is five.

C.5.4 Damp heat

EUT	Two sample instruments of the submitted type, set-up according to clause C.2.1.
Spare unit	A sample instrument of the submitted type, set-up according to clause C.2.1. and maintained at reference conditions for the duration of the test.
Grain samples	One set from a single grain type comprised of three samples that represent the legally relevant <i>PMB</i> range (i.e., one sample for each low, mid and high <i>PMB</i>). Allowable grains are specified by the national responsible body. Wheat is the preferred grain type. Except during analysis, each sample is kept in its enclosure during the test. The enclosed samples are only introduced to the damp heat two hours prior to testing. Samples used in a climatic test shall not be reused in other tests.
Standards	IEC 60068-2-78 [16], IEC 60068-3-4 [17]
Test method and procedure (in brief)	Test Cab: Damp heat, steady state. The test consists of exposure to the specified maximum temperature and the specified constant relative humidity for the specified time. The change of temperature shall not exceed 1 °C/min during heating up and cooling down. The absolute humidity of the test atmosphere shall not exceed 20 g/m ³ . When testing is performed at temperatures lower than 35 °C, the relative humidity shall not exceed 50 %. Six <i>PMB</i> measurements on every sample are taken using each unit, at every test condition: i) EUT and grain samples at reference temperature ii) EUT after damp heat exposure, grain samples at maximum temperature and RH iii) EUT and grain samples after recovery at reference conditions
Sample monitoring	To ensure that heating, exposure to moisture and recovery do not change the <i>PMB</i> of grain samples significantly, the grain samples are monitored by a spare unit.
Test severity	Exposure duration (after EUT stabilisation): two days; Maximum RH: 85 % Maximum temperature: TH or 30 °C TH is the maximum temperature in the operating range specified by the national responsible body.
Suggested steps	1) The EUT is powered on and stabilised at reference temperature. 2) In a separate chamber, the spare unit is powered on and equilibrated at reference temperature with the grain samples. 3) Sample 1 is analysed once on instrument 1, then once on instrument 2, then once on the spare unit. Further <i>PMB</i> measurements are taken across the three units in the same manner, until six <i>PMB</i> measurements are recorded for each instrument. 4) Step 3 is repeated for the other two grain samples. 5) The EUT is subjected to the maximum temperature and humidity and stabilised. The exposure duration is observed. Two hours prior to the end of the exposure duration, the enclosed grain samples are introduced to damp heat conditions. 6) All the hot grain samples are analysed in turn on both units of the EUT, alternating between the two instruments, until three <i>PMB</i> measurements per grain samples are recorded for each instrument. 7) The samples are retained at the location of the EUT for as long as necessary to equilibrate at

	the maximum temperature. Each sample is analysed three times on both units of the EUT again. 8) After ensuring that six <i>PMB</i> measurements on each hot sample are recorded for each instrument, the EUT and grain samples are recovered to reference temperature. 9) Steps 3 – 4 are repeated.
Test result	Values for the error shift on every grain sample are calculated at each test condition for each unit (of the EUT). Error shift (damp heat) = (Mean <i>PMB</i> condition ii – Mean <i>PMB</i> condition i) Error shift (recovery) = (Mean <i>PMB</i> condition iii – Mean <i>PMB</i> condition i) – Correction* *Application of a correction is required if a significant change in the sample <i>PMB</i> during heating and/or recovery is indicated by the sample stability test.
Grain sample stability test and correction	The <i>PMB</i> variation on a grain sample <i>calculated from measurements on the spare unit</i> , shall be within the limit in Table 4 column 9 for no correction to apply. Sample <i>PMB</i> variation (recovery) = Mean <i>PMB</i> (condition iii) – Mean <i>PMB</i> (condition i) Any sample <i>PMB</i> variation that exceeds the limit, shall be applied as a correction, e.g., Sample <i>PMB</i> variation (recovery) = Correction for error shift (recovery)
Acceptance requirements	All values for the error shift (i.e. with any necessary correction) shall be within the limit in clause 4.5 Table 4 column 9. All operational functions shall operate as designed.

During the August 2013 Grain Analyzer Sector meeting, the Sector reviewed the proposal to replace the NTEP Publication 14 GMM and NIR humidity test procedure with the OIML D 11 damp heat test procedure. It was noted that the proposed changes to the humidity test in NCWM Publication 14 were based on OIML D 11 requirements Damp heat test, Severity level 1. During discussion of this item, It was mentioned that the temperature and humidity levels as specified in OIML D 11 may pose unsafe operating conditions to laboratory staff and also that grain moisture meters are not designed to operate in these extreme conditions. A question was asked if another severity level in D 11 would more closely match the testing that is currently in NCWM Publication 14 and that has been used for many years in the United States. Ms. Lee, reviewed OIML D 11 requirements following the meeting and found that both severity level 1 and 2 exceed the temperature and humidity levels specified in NCWM Publication 14.

Conclusion:

The Sector agreed by consensus that the OIML D 11, Damp heat test, is much too severe for grain moisture meters and that Publication 14 should not be changed to meet the requirements of OIML D 11.

11. Report on OIML TC 17/SC 8 Protein Measuring Instruments for Cereal Grain and Oil Seeds

Background/Discussion:

This item was included on the Sector’s agenda to provide a summary of the activities of OIML TC 17/SC 8 to the Grain Analyzer Sector and to those Sector members that participate on the U.S. National Working Group (USNWG) on grain protein measuring instruments. OIML TC 17/SC 8 was formed to study the issues and to develop a Recommendation on *Protein Measuring Instruments for Cereal Grain and Oil Seeds*. Australia is the Secretariat for this subcommittee. The third committee draft (3 CD) for this Recommendation was circulated to the U.S. National Working Group for comments on July 3, 2012, for review and comment and comments were requested by September 8, 2012. The U.S. comments to 3 CD were forwarded to the Secretariat and the Secretariat developed the 4 CD based on these comments.

The 4 CD was circulated to the USNWG on grain protein measuring instruments on April 9, 2013 and comments to the 4 CD of TC 17/SC 8 were requested by June 13, 2013. The U.S. comments to the 4 CD were forwarded to the Secretariat. The United States was requested to vote on the 4 CD and a vote of no was provided due to a number of differences in the test procedures of the OIML Recommendation for *Protein Measuring Instruments for Cereal Grain and Oil Seeds* and the OIML Recommendation 59 *Moisture Meters for Cereal Grain and Oilseeds*.

A meeting was hosted by NIST, OWM, July 24 - 25, 2013, to discuss the comments to the 4 CD for the Recommendation on *Protein Measuring Instruments for Cereal Grain and Oil Seeds*. Discussions on 4 CD dealt

mostly with harmonization of testing with the 6 CD of the OIML Recommendation R 59 *Moisture Meters for Cereal Grain and Oilseeds*, software requirements, and influence quantities and test sample temperature.

At the August 2013 Grain Analyzer Sector Meeting, the the Sector reiterated their concerns with the OIML D 11 damp heat test.

Conclusion:

The Sector agreed that the damp heat test in OIML Recommendation on Protein Measuring Instruments for Cereal Grain and Oil Seeds, 4 CD should be replaced with the humidity test as written in OIML R 59 CD 6.

12. Software Sector Items

(a) Identification of Certified Software

Source:

NTETC Software Sector

Purpose:

Review and provide comment to the Software Sector reports and conclusion on software issues.

Background:

This item originated as an attempt to answer the question “How does the field inspector know that the software running in the device is the same software evaluated and approved by the lab? In previous meetings it was shown that the international community has addressed this issue (both WELMEC and OIML).

From WELMEC 7.2:

Required Documentation:

The documentation shall list the software identifications and describe how the software identification is created, how it is inextricably linked to the software itself, how it may be accessed for viewing and how it is structured in order to differentiate between version changes with and without requiring a type approval.

From OIML D-31:

The executable file “**tt100_12.exe**” is protected against modification by a checksum. The value of checksum as determined by algorithm **XYZ** is **1A2B3C**.

Previous discussions have included a listing of some additional examples of possible valid methods (not limiting):

- CRC (cyclical redundancy check)
- Checksum
- Inextricably Linked version no.
- Encryption
- Digital Signature

Is there some method to give the weights and measures inspector information that something has changed?

Yes, the Category III Audit Trail or other means of sealing.

How can the weights and measures inspector identify an NTEP Certified version?

They can't, without adding additional requirements like what is described here, in conjunction with including the identifier on the CC).

The Sector believes that we should work towards language that would include a requirement similar to the International Organization of Legal Metrology (OIML) requirement in NIST Handbook 44. It is also the opinion of

the Sector that a specific method should not be defined; rather the manufacturer should utilize a method and demonstrate the selected identification mechanism is suitable for the purpose. It is not clear from the discussion where such proposed language might belong.

NTEP strongly recommends that metrological software be separated from non-metrological software for ease of identification and evaluation.

From OIML:

Separation of software parts – All software modules (programmes, subroutines, objects etc.) that perform metrologically significant functions or that contain metrologically significant data domains form the metrologically significant software part of a measuring instrument (device or sub-assembly). The conformity requirement applies to all parts and parts shall be marked according to Section G-S-X.X.

If the separation of the software is not possible or needed, then the software is metrologically significant as a whole.

(Segregation of parameters is currently allowed - see table of sealable parameters)

Initial draft proposed language: (G-S.1.1.?)

NIST Handbook 44 (This has been written into G-S.1.d.3): Identification of Certified Software:

Software-based electronic devices shall be designed such that the metrologically significant software is clearly identified by the version or revision number. The identification, and this identification of the software shall be inextricably directly and inseparably linked to the software itself. The version or revision number may consist of more than one part, but at least one part shall be dedicated to the metrologically significant software.

From NCWM Publication 14:

Identification of Certified Software:

Note: Manufacturers may choose to separate metrologically significant software from non-metrologically significant software. Separation would allow the revision of the non-metrological portion without the need for further evaluation. In addition, non-metrologically significant software may be updated on devices without breaking a seal, if so designed. Separation of software requires that all software modules (programs, subroutines, objects, etc.) that perform metrologically significant functions or that contain metrologically significant data ~~domains~~ form the metrologically significant software part of a measuring instrument (device or sub-assembly) . If the separation of the software is not possible or needed, then the software is metrologically significant as a whole. ~~The conformity requirement applies to all parts and parts shall be marked according to Section G-S-X.X.~~

The manufacturer must describe and possibly demonstrate how the version or revision identifier is directly and inseparably linked to the metrologically significant software. Where the version revision identifier is comprised of more than one part, the manufacturer shall describe which portion represents the metrological significant software and which does not.

From OIML D-31:

Legally relevant software of a measuring instrument/electronic device/sub-assembly shall be clearly identified with the software version or another token. The identification may consist of more than one part but at least one part shall be dedicated to the legal purpose.

The identification shall be inextricably linked to the software itself and shall be presented or printed on command or displayed during operation or at start up for a measuring instrument that can be turned off and on again. If a sub-assembly/an electronic device has neither display nor printer, the identification shall be sent via a communication interface in order to be displayed/printed on another sub-assembly/electronic device.

The first sentence of the first paragraph above is already addressed in NIST Handbook 44's marking requirements.

In 2010, the Sector recommended the following change to NIST Handbook 44, General Code: G-S.1.(d) to add a new subsection (3):

(d) *the current software version or revision identifier for ~~not built for purpose~~ software-based electronic devices;*

[Nonretroactive as of January 1, 2004]

(Added 2003) **(Amended 20XX)**

(1) *The version or revision identifier shall be prefaced by words, an abbreviation, or a symbol, that clearly identifies the number as the required version or revision.*

[Nonretroactive as of January 1, 2007]

(Added 2006)

(2) *Abbreviations for the word "Version" shall, as a minimum, begin with the letter "V" and may be followed by the word "Number." Abbreviations for the word "Revision" shall, as a minimum, begin with the letter "R" and may be followed by the word "Number." The abbreviation for the word "Number" shall, as a minimum, begin with the letter "N" (e.g., No or No.).*

[Nonretroactive as of January 1, 2007]

(Added 2006)

(3) The version or revision identifier shall be directly and inseparably linked to the software itself. The version or revision identifier may consist of more than one part, but at least one part shall be dedicated to the metrologically significant software.

[Nonretroactive as of January 1, 201X]

(Added 20XX)

Also the Sector recommended the following information be added to NCWM Publication 14 as explanation/examples:

- Unique identifier must be displayable/printable on command or during operation, etc.
- At a minimum, a version/revision indication (1.02.09, rev 3.0 a, etc.). Could also consist of/contain checksum, etc. (crc32, for example)

There was some additional discussion on this item regarding where this new requirement was best located. It was suggested that the first sentence of G-S.1.d.(3) could be added as a clause to the base paragraph G-S.1.(d) text, (e.g., "*the current software version or revision identifier for ~~not built for purpose~~ software-based devices, which shall be directly and inseparably linked to the software itself;*").

It also was suggested that the second sentence in G-S.1.d.(3) might be more suitable for *NCWM Publication 14*, as it describes more "how" than "what" the requirement entails.

In addition, the Sector considered the following information to be added to *NCWM Publication 14* as explanation/examples:

- The current software identifier must be displayable/printable on command during operation (or made evident by other means deemed acceptable by G-S.1.).

- At a minimum, the software identifier must include a version/revision indication (1.02.09, rev 3.0 a, etc). It could also consist of/contain checksum, etc (crc32, for example).
- The version or revision identifier may consist of more than one part, but at least one part shall be dedicated to the metrologically significant software.

Other questions that are still outstanding:

- If we allow hard-marking of the software identifier (the Sector has wavered on this in the past), does the above wording then imply that some mechanical means is required (i.e., physical seal) to "inseparably link" the identifier to the software?
- If a device is capable of doing so, does it still have to be able to display, print or communicate the identifier somehow, even if it is hard-marked?

At the 2012 NTETC Software Sector Meeting, there was some discussion as to where the terminology regarding inextricably linking the software version or revision to the software itself belonged. At the moment, it is not incorporated in the proposed text for G-S.1. NCWM Publication 14 may be a better option for the time being. This would be another item that would benefit from further explanation in a supplementary document.

Several Sector members were of the opinion that attempting to make this change at the same time as the earlier changes might be a difficult sell. Mr. Truex, NTEP Administrator, reiterated the necessity of baby steps.

In 2012, the Sector thus recommended adding the following to NCWM Publication 14 and forward to NTETC Weighing, Measuring, Grain Analyzer Sectors for feedback:

Identification of Certified Software:

Note: Manufacturers may choose to separate metrologically significant software from non-metrologically significant software. Separation would allow the revision of the non-metrological portion without the need for further evaluation. In addition, non-metrologically significant software may be updated on devices without breaking a seal, if so designed. Separation of software requires that all software modules (programs, subroutines, objects, etc.) that perform metrologically significant functions or that contain metrologically significant data domains form the metrologically significant software part of a measuring instrument (device or sub-assembly). If the separation of the software is not possible or needed, then the software is metrologically significant as a whole. The conformity requirement applies to all parts and parts shall be marked according to Section G-S-X.X.

The manufacturer must describe and possibly demonstrate how the version or revision identifier is directly and inseparably linked to the metrologically significant software. Where the version revision identifier is comprised of more than one part, the manufacturer shall describe which portion represents the metrological significant software and which does not.

Discussion:

The Measuring Sector reviewed this item and had no feedback other than a statement that they support the continuing/ongoing efforts of this Sector. The Weighing Sector summary mentioned that no one opted to provide comment. They agreed to take no further action on this item, pending further action from the Software Sector. This was specifically in reference to the accepted symbols.

For the time being, Jim Truex recommended that we not attempt to provide a definition for "software-based device."

We discussed the possibility of combining this change with the first agenda item, which had been attempted in previous years. Alternatively, if the NIST Handbook 44 changes from agenda item 1 are made, this agenda item could be addressed in NCWM Publication 14.

Conclusion:

After further discussion, the wording in G-S.1.(d) under agenda item 1 was changed. Agenda Item 2 will remain; however, it will address potential changes to NCWM Publication 14 and contain no suggested modifications to NIST Handbook 44. (See changes and conclusion under agenda item 1 for further details).

The Sector Chair volunteered to review the existing slide presentation detailing the purpose of these changes, to ensure that it accurately reflects this information.

(b) Software Protection/Security

Source:

NTETC Software Sector

Background:

The Sector agreed that NIST Handbook 44 already has audit trail and physical seal, but these may need to be enhanced.

From the WELMEC Document:

Protection against accidental or unintentional changes

Metrologically significant software and measurement data shall be protected against accidental or unintentional changes.

Specifying Notes:

Possible reasons for accidental changes and faults are: unpredictable physical influences, effects caused by user functions and residual defects of the software even though state of the art of development techniques have been applied.

This requirement includes consideration of:

- a) Physical influences: Stored measurement data shall be protected against corruption or deletion when a fault occurs or, alternatively, the fault shall be detectable.
- b) User functions: Confirmation shall be demanded before deleting or changing data.
- c) Software defects: Appropriate measures shall be taken to protect data from unintentional changes that could occur through incorrect program design or programming errors (e.g., plausibility checks).

Required Documentation:

The documentation should show the measures that have been taken to protect the software and data against unintentional changes.

Example of an Acceptable Solution:

- The accidental modification of software and measurement data may be checked by calculating a checksum over the relevant parts, comparing it with the nominal value and stopping if anything has been modified.
- Measurement data are not deleted without prior authorization, e.g. a dialogue statement or window asking for confirmation of deletion.
- For fault detection see also Extension I.

The Sector continued to develop a proposed checklist for NCWM Publication 14. The numbering will still need to be added. This is based roughly on R 76-2 checklist and discussions beginning as early as the October 2007 NTETC Software Sector Meeting. The information requested by this checklist is currently voluntary, however, it is recommended that applicants comply with these requests or provide specific information as to why they may not be

able to comply. Based on this information, the checklist may be amended to better fit with NTEP's need for information and the applicant's ability to comply.

The California, Maryland, and Ohio laboratories agreed to use this check list on one of the next devices they have in the lab and report back to the Sector on what the problems may be. In February 2011, the North Carolina laboratory was also given a copy of the checklist to try.

1. Devices with Embedded Software TYPE P (aka built for purpose)

- 1.3. Declaration of the manufacturer that the software is used in a fixed hardware and software environment. **AND** Yes No N/A
- 1.4. Cannot be modified or uploaded by any means after securing/verification. Yes No N/A
Note: It is acceptable to break the "seal" and load new software, audit trail is also a sufficient seal.
- 1.5. The software documentation contains:
 - 1.5.3. Description of all functions, designating those that are considered metrologically significant. Yes No N/A
 - 1.5.4. Description of the securing means (evidence of an intervention). Yes No N/A
 - 1.5.5. Software Identification, **including version/revision** Yes No N/A
 - 1.5.6. Description how to check the actual software identification. Yes No N/A
- 1.6. The software identification is:
 - 1.6.7. Clearly assigned to the metrologically significant software and functions. Yes No N/A
 - 1.6.1. Description how to check the actual software identification. Yes No N/A
 - 1.6.2. Provided by the device as documented. Yes No N/A
 - 1.6.3. **Directly linked to the software itself.** Yes No N/A

2. Personal Computers, Instruments with PC Components, and Other Instruments, Devices, Modules, and Elements with Programmable or Loadable Metrologically Significant Software TYPE U (aka not built for purpose)

- 2.1. The metrologically significant software is:
 - 2.1.4. Documented with all relevant (see below for list of documents) information. Yes No N/A
 - 2.1.5. Protected against accidental or intentional changes. Yes No N/A
- 2.2. Evidence of intervention (such as, changes, uploads, circumvention) is available until the next verification/inspection (e.g., physical seal, Checksum, **Cyclical Redundancy Check (CRC)**, audit trail, etc. means of security). Yes No N/A

3. Software with Closed Shell (no access to the operating system and/or programs possible for the user)

- 3.1. Check whether there is a complete set of commands (e.g., function keys or commands via external interfaces) supplied and accompanied by short descriptions. Yes No N/A
- 3.2. Check whether the manufacturer has submitted a written declaration of the completeness of the set of commands. Yes No N/A

4. Operating System and/or Program(s) Accessible for the User

- 4.1. Check whether a checksum or equivalent signature is generated over the machine code of the metrologically significant software (program module(s) subject to legal control Weights and Measures jurisdiction and type-specific parameters). Yes No N/A
- 4.2. Check whether the metrologically significant software will detect and act upon any unauthorized alteration of the metrologically significant software using simple software tools (e.g., text editor). Yes No N/A

5. Software Interface(s)

- 5.1. Verify the manufacturer has documented:
- 5.1.6. The program modules of the metrologically significant software are defined and separated. Yes No N/A
- 5.1.7. The protective software interface itself is part of the metrologically significant software. Yes No N/A
- 5.1.8. The functions of the metrologically significant software that can be accessed via the protective software interface. Yes No N/A
- 5.1.9. The parameters that may be exchanged via the protective software interface are defined. Yes No N/A
- 5.1.10. The description of the functions and parameters are conclusive and complete. Yes No N/A
- 5.1.11. There are software interface instructions for the third party (external) application programmer. Yes No N/A

The Maryland laboratory had particular questions regarding 3.1 and 5.1. The information for 3.1 could be acquired from an operator's manual, a training video, or in-person training. The items in 5.1 were confusing to the evaluators. The terminology is familiar to software developers, but not necessarily others. It was indicated that manufacturers were typically quick to return the filled out questionnaire, but he didn't know how his laboratory was supposed to verify that it was true. Generally, the laboratories wouldn't be expected to verify things to that level. For example, if the manufacturer states that a checksum is used to ensure integrity, the laboratories wouldn't be expected to evaluate the algorithm used.

The intent was to see whether the manufacturer had at least considered these issues, not for evaluators to become software engineers. Perhaps a glossary or descriptive paragraphs might be added to assist the evaluators for if the manufacturer has questions for the evaluators.

OIML makes use of supplementary documents to explain the checklist they use. Below are links:

<http://www.oiml.org/publications/D/D031-e08.pdf>

<http://www.welmec.org/latest/guides/72.html>

http://www.welmec.org/fileadmin/user_files/publications/2-3.pdf

WELMEC Document 2.3 is the original source for our checklist, but it's been significantly revised and simplified. Mr. Payne, Maryland Department of Agriculture, is going to review the other documents and come up with some suggestions for the checklist. Mr. Roach, California Division of Measurement Standards, is going to begin using the checklist. The international viewpoint is that any device running an operating system is considered to be Type U. Mr. Roach mentioned that they're having lots of problems with "skimmers" stealing PIN's. Is there some way they can detect this?

Mr. Lewis, Rice Lake Weighing Systems, Inc., mentioned that he liked Measurement Canada's website. When answering similar questions, different pages would appear, based on answers to those questions: <http://www.ic.gc.ca/eic/site/mc-mc.nsf/eng/lm00573.html>.

At the 2011 NTETC Software Sector Meeting, the laboratories were polled to obtain any feedback on the use of the checklist. Maryland attempted to use this checklist a few times. They had some difficulty obtaining answers from the manufacturers because the individual(s) interacting with the Maryland evaluator didn't always have the required information on hand. More experience in using the checklist will help determine what needs to be revised.

It was suggested that the checklist could be sent to manufacturers for their feedback as well, with the stipulation that it a completely voluntary exercise and purely informational at this point. The laboratories will coordinate with willing manufacturers to obtain feedback.

Work is ongoing on this item with the intent that it eventually will be incorporated as a checklist in NCWM Publication 14; again the laboratories are requested to try utilizing this checklist for any evaluations on software-based electronic devices.

The checklist has been reviewed with an eye to making its terminology clearer to laboratories. Some examples and clarifications have been added as shown in the discussion section of this item. The revised checklist will be distributed to the laboratories for additional review. Maryland and California laboratories agreed to use the checklist on a trial basis.

Discussion:

Over the past year, attempts to use the current checklist did not meet with many difficulties. The checklists were given to the manufacturers to fill out, and that seemed to work rather well. Minor modifications (in red above) were made to clarify certain confusing areas or eliminate redundancy

Conclusion:

The next step will be to forward it to the four Sectors; we can report that the labs have tried using it on a trial basis, and we're ready to recommend it for NCWM Publication 14 with the modification suggested here, such as the removal of the Type P/Type U wording.

(c) Software Maintenance and Reconfiguration

Source:

NTETC Software Sector

Background:

After the software is completed, what do the manufacturers use to secure their software? The following items were reviewed by the Sector. *Note that agenda Item 3 also contains information on Verified and Traced updates and Software Log.*

1. Verify that the update process is documented. (OK)
2. For traced updates, installed Software is authenticated and checked for integrity.

Technical means shall be employed to guarantee the authenticity of the loaded software (i.e., that it originates from the owner of the type approval certificate). This can be accomplished (e.g., by cryptographic means like signing). The signature is checked during loading. If the loaded software fails this test, the instrument shall discard it and either use the previous version of the software **or become inoperative.**

Technical means shall be employed to guarantee the integrity of the loaded software (i.e., that it has not been inadmissibly changed before loading). This can be accomplished for example, by adding a checksum or hash code of the loaded software and verifying it during the loading procedure. If the loaded software fails this test, the instrument shall discard it and either use the previous version of the software **or become inoperative.**

Examples are not limiting or exclusive.

3. Verify that the sealing requirements are met.

The Sector asked, “What sealing requirements are we talking about”?

This item is **only** addressing the **software update**, it can be either verified or traced. It is possible that there are two different security means, one for protecting software updates (software log) and one for protecting the other metrological parameters (Category I II or III method of sealing). Some examples provided by the Sector members include but are not limited to:

- Physical seal, software log
- Category III method of sealing can contain both means of security

4. Verify that if the upgrade process fails, the device is inoperable or the original software is restored

The question before the group is, Can this be made mandatory?

The manufacturer shall ensure by appropriate technical means (e.g., an audit trail) that traced updates of metrologically significant software are adequately traceable within the instrument for subsequent verification and surveillance or inspection. This requirement enables inspection authorities, which are responsible for the metrological surveillance of legally controlled instruments, to back-trace traced updates of metrologically significant software over an adequate period of time (that depends on national legislation). The statement in italics will need to be reworded to comply with US weights and measures requirements.

The Sector **agreed** that the two definitions below for Verified Update and Traced Update were acceptable.

Verified Update

A verified update is the process of installing new software where the security is broken and the device must be re-verified. Checking for authenticity and integrity is the responsibility of the owner/user.

Traced Update

A traced update is the process of installing new software where the software is automatically checked for authenticity and integrity, and the update is recorded in a software update log or audit trail.

Note: It's possible that the Philosophy of Sealing section of NCWM Publication 14 may already address the above IF the definitions of Verified and Traced Updates (and the statement below) were to be added. The contrary argument was that it may be better to be explicit).

Use of a Category 3 audit trail is required for a Traced Update. A log entry representing a traced software update shall include the software identification of the newly installed version.

The Sector recommended consolidating the definitions with the above statement thus:

Verified Update

A verified update is the process of installing new software where the security is broken and the device must be re-verified. Checking for authenticity and integrity is the responsibility of the owner/user.

Traced Update

A traced update is the process of installing new software where the software is automatically checked for authenticity and integrity, and the update is recorded in a ~~software update log or~~ Category 3 audit trail. The audit trail entry shall include the software identification of the newly installed version.

In 2012, the Sector recommended that as a first step, the following be added to NCWM Publication 14:

The updating of metrologically significant software, including software that checks the authenticity and integrity of the updates, shall be considered a sealable event.

Mr. Truex, NTEP Administrator, indicated his opinion that the above sentence is unnecessary since it's self-evident. It was agreed by the group however to ask the other Sectors for feedback on the value of this addition.

Though the Sector is currently considering only the single sentence be incorporated into NCWM Publication 14 for the time being, ultimately, the Sector may wish to advance the remaining language of the original item submission.

Discussion:

The Sector had no information indicating that the other Sectors had yet been approached for feedback on the value of the addition of the proposed sentence.

Conclusion:

This Sector would like the other Sectors to evaluate this for inclusion in NCWM Publication 14. We'd also like to include some description indicating that an existing audit trail should be protected during a software update, though that may already be a requirement. This does appear to be addressed in the Requirements for Metrological Audit Trails Appendices in NCWM Publication 14.

At the August 2013 Grain Analyzer Sector Meeting, Mr. Truex provided a review of the Software Sector's proposals for changes to NCWM Publication 14 Identification of Certified Software, Software Protection/Security, and Software Maintenance and Reconfiguration. Manufacturers had a number of question to include "What is the baseline for which software is considered metrologically significant?" After some discussion the manufacturers requested that they be given additional time to review the proposed changes and to allow their software designers an opportunity to look at the proposed changes to software. Ms. Brenner sent an e-mail on August 29, 2013, to all NTEP grain analyzer manufacturers requesting that comments be submitted to Ms. Lee by October 15, 2013.

Conclusion:

Grain Analyzer Manufacturers provided the following comments to the Software Sector's proposal for changes to NCWM Publication 14:

Grain Analyzer Manufacturer’s Comments to Software Sector’s Proposed Changes to Publication 14			
Manufacturer	GA Sector Item	Comment	Proposed change
Dickey-john	12a	<p>We currently don’t separate the metrologically significant code or identify it’s version in the application. We can do this, but it will require a significant code change and validation.</p> <p>Question 1: Does the metrological significant code need to be actually separate from the application or is a label in the application identifying the version of the prediction module used acceptable. This will result in less changes to the code.</p> <p>Question 2: What if we had added a test on the prediction module that inserted key values into the engine, that we would document in the metrological specific tests, that would give a specific answer? For example, if the prediction module is the same then the same inputs with the same calibration file will yield the same results from version to version; log those results and include in the metrological report.</p>	<p>Object to 12.a – The document insists that we separate the legally relevant code and make separate binaries.</p> <p>We could simply add a label that is bound to the prediction module code. Adding this label could tie the prediction module to the version, and will allow us to separately maintain revision control of that code. However, the code itself will not be a separate binary.</p>
FOSS	General	<p>Since FOSS distributes instruments worldwide, having NTEP and OIML requirements the same would be beneficial. I know efforts are being made to have the 2 as similar as possible. A concern is the potential that software code that is adopted would invalidate the currently approved instruments. A preferred outcome would be that once software code is adopted, only instruments seeking approval (not currently approved) would be required to meet the code.</p>	

In addition manufacturers that attended the August 2013 Grain Analyzer Meeting, expressed an interest in attending the next 2014 Software Sector meeting to provide additional input.

13. Update on Proficiency Testing

Source:

Dr. Hurburgh, Iowa State University

Purpose:

Develop an air-oven proficiency testing program to ensure state laboratory and manufacturers air-oven measurements are traceable to the official USDA, GIPSA air-oven measurements.

Item Under Consideration:

Update on progress of the ongoing air-oven proficiency testing program for states maintaining a grain moisture laboratory and GMM manufacturers.

Background/Discussion:

At the 2009 NTETC Grain Analyzer Sector Meeting, Dr. Hurburgh, Iowa State University, urged the representatives from the American Oil Chemists Society (AOCS) to prepare a proposal so that the collaborative (air-oven) study could be conducted on an on-going basis rather than on an ad hoc basis. He cautioned that the proposal would have to include corn and wheat as well as soybeans.

At the 2011 NTETC Grain Analyzer Sector Meeting, Ms. Johnson, AOCS, proposed an air-oven/GMM proficiency testing series designed specifically to address the needs of GMM manufacturers and states maintaining a grain moisture laboratory. AOCS would administer the program, oversee distribution of samples, compile results, perform statistical analysis of results, and distribute a report to participants. AOCS does not collect the samples. This is subcontracted to suitable providers. AOCS does not have laboratories. Since GIPSA/FGIS is a certified laboratory already participating in the AOCS Soybean Quality Traits program, GIPSA air-oven results could be reported for comparison.

At the Sector's August 2012 meeting, the Sector learned that Ms. Christine Atkinson will be taking over the Proficiency Testing program for States and interested manufacturers formerly headed by Ms. Amy Johnson. Ms. Atkinson verified that participant's cost will remain \$100 per year. The Sector reiterated that the program should focus solely on the standard FGIS air-oven method. Instrument results will not be reported. Participants' air-oven results will be compared against GIPSA's standard FGIS air-oven results. In response to Ms. Atkinson's question about scheduling, the Sector was in general agreement that samples should ship after harvest, preferably between mid-January and mid-February with participants' results due 30 days after the shipping date.

The Sector agreed upon the following Program Details:

Samples – Soybeans 2, Corn 2, Hard Red Winter Wheat 2

- Cost to Participants - \$100/year
- Schedule:
 - Samples (6) ship between January 15 and February 15.
 - Samples must be tested within 5 business days of receipt with results due 30 days after the shipping date.
- Reports to be posted on www.SoybeanQualityTraits.org by 1 May.
- Only the GIPSA oven results will be identified. Individual manufacturer's and State participant's oven results will be assigned an identifier known only to the manufacturer or State participant. Instrument results will not be reported.
- Detailed Participant Instructions will be provided to each participant.

An update on any progress of proficiency testing will be discussed at the Sector meeting.

At the August 2013 Grain Analyzer Sector meeting, no report was provided on AOAC's efforts to conduct proficiency testing for grain moisture. Mr. Karl Cunningham, Illinois, and Mr. Kenvin Hansan agreed to work together to conduct a grain moisture proficiency test.

Conclusion:

Mr. Cunningham agreed to provide the samples for proficiency testing and Mr. Hansan agreed to analyze the data in accordance with the procedures used to conduct proficiency testing in the state laboratory program. Mr. Hansan also agreed to collect data on test weight per bushel which may be useful in field test procedures for evaluating test weight per bushel on instruments. See agenda item 9 for the discussion on test weight per bushel.

14. The Feasibility of a Phase II program for Near Infrared Grain Analyzers

Source:

Dr. Hurburgh, Iowa State University

Background/Discussion:

The GIPSA Grain Inspection Advisory Committee recommends that GIPSA initiate research to determine the feasibility of extending the theory of “equivalency” to multiple-constituent instruments in order to utilize standardized technology while maintaining accuracy and consistency in measurement of wheat protein.

Ms. Eigenmann provided an update on the Grain Inspection Advisory Committee’s Resolutions. The Sector discuss the feasibility of an ongoing calibration program also referred to as a Phase II program for Near Infrared Grain Analyzers (NIR) instruments that measure wheat program. The Phase II program for grain moisture is a program that monitors the moisture calibrations on grain moisture meters annually. As changes to the calibrations occur due to grains, climate, etc., data collected in this program allows for changes to moisture calibrations annually and ensure equivalency among the different moisture meter models. The Advisory committee is recommending that this program be extended to include NIR instruments that measure wheat protein. It was noted that there could be multiple NIR instruments for wheat protein introduced into the market and that it may be advisable to have the Phase II program extended to NIR instruments that measure wheat protein. It was also mentioned that currently there are few States that are checking wheat protein on multi-constituent instruments.

GIPSA currently has an annual review program for the official protein system but would have to consider the cost associated with extending the program for other NIR wheat protein analyzers. It was noted during the discussion that GIPSA currently has hourly rate fees set that could be applied to a phase II program for wheat program.

Unlike moisture where there may be changes to the calibrations annually, there will not be year to year changes for wheat protein. As such, consideration may be given to conducting the program less than annually, and considering reviewing wheat protein calibrations every 3, 4, or 5 years, as appropriate. In addition it was noted that there also has to be a mechanism to get manufacturers calibration data for calibration review.

Conclusion:

The Sector will continue to discuss the feasibility of a phase II program for wheat protein giving consideration to the following issues:

- How the program will be funded,
- How often the calibrations for wheat protein will be updated, which will likely affect the cost,
- How many devices are currently being used in commercial transactions, and
- If being used commercially in a State, what is needed by States to begin testing these devices.

15. Next Sector Meeting

The next meeting is tentatively planned for Wednesday, August 20 and Thursday, August 21, 2014, at the Chase Suites by Woodfin at KCI in Kansas City, MO. Sector members are asked to hold these days open pending confirmation of availability of facility, determination of agenda items, exact meeting times, and meeting duration. Final meeting details will be announced by early June 2014.

If you would like to submit an agenda item for the 2014 meeting, please contact any of the following persons by June 1, 2014:

Jim Truex, NTEP Administrator at jim.truex@ncwm.net
G. Diane Lee, NIST Technical Advisor, at diane.lee@nist.gov

16. Update on the New Meter Technology

Background/Discussion:

During the August 2013 Grain Analyzer Sector meeting, Dr. David Funk, Deputy Director and Chief Scientist, GIPSA-FGIS, Technology and Science Division, updated the Sector on the new Unified Grain Moisture Algorithm (UGMA) meter technology.

Since the August 2012 Grain Analyzer Sector, the implementation of the new UGMA moisture meters for official inspection of corn, soybeans, sorghum, and sunflowers occurred on September 10, 2012, at which time the Perten AM 5200-A and the Dickey-john GAC 2500-UGMA replaced the Dickey-john GAC 2100 as the approved moisture meter models for those grains. The conversion to the use of UGMA-Compatible moisture meters was completed on May 1, 2013, with all officially-inspected grains and commodities switched to the UGMA-Compatible moisture meters. As of May 1, 2013, the GAC 2100 is no longer approved for official inspection of any grain or commodity under FGIS jurisdiction.

There was further discussion of test weight and the UGMA meters and the variation in different test methods. It was noted that the ISO and U.S. methods for test weight differ in the kettle size and fill method which contributes to variations in the results of the two methods. Also, both methods are user dependent.

Dr. Funk mentioned that tests were being performed reviewing the Official UGMA meter test weight per bushel measurement results to determine if these measurements could be used for Official test weight per bushel measurements. It was noted that results may be available from this testing in September 2013. The use of UGMA meters to determine official test weight per bushel results would expedite the official test weight measurement and might provide for greater uniformity.

Additional information on UGMA moisture meter implementation can be found on the GIPSA web page: <http://www.gipsa.usda.gov/fgis/equipment.html>.

THIS PAGE INTENTIONALLY LEFT BLANK

Appendix D

National Type Evaluation Technical Committee (NTETC) Measuring Sector Annual Meeting Summary

October 9 - 10, 2013
Charleston, West Virginia

INTRODUCTION

The charge of the NTETC Measuring Sector (herein after referred to as “Sector”) is to provide appropriate type evaluation criteria based on specifications, tolerances and technical requirements of NIST Handbook 44, *Specifications, Tolerances, and Other Technical Requirements for Weighing and Measuring Devices*, Sections 1.10. General Code and all portions of Section 3 including codes for Liquid Measuring Devices, Vehicle Tanks Meters, Liquid Petroleum Gas and Anhydrous Ammonia Measuring Devices, Cryogenic Liquid Measuring Devices, Milk Meters, Water Meters, Mass Flow Meters, and Carbon Dioxide Liquid Measuring Devices. The Sector’s recommendations are presented to the National Type Evaluation Program (NTEP) Committee each January for approval and inclusion in NCWM Publication 14, *Technical Policy, Checklists, and Test Procedures* for national type evaluation.

The Sector is also called upon occasionally for technical expertise in addressing difficult NIST Handbook 44 issues on the agenda of National Conference on Weights and Measures (NCWM) Specifications and Tolerances (S&T) Committee. Sector membership includes industry, NTEP laboratory representatives, technical advisors, and the NTEP Administrator. Meetings are held annually, or as needed and are open to all NCWM members and other registered parties.

Proposed revisions to the handbook(s) are shown as follows: 1) deleted language is indicated with a **bold face font using strikeouts** (e.g., ~~this report~~), 2) proposed new language is indicated with an **underscored bold faced font** (e.g., new items), and 3) nonretroactive items are identified in *italics*. There are instances where the Sector will use **red** text and/or **highlighted** text to bring emphasis to text that requires additional attention. When used in this report, the term “weight” means “mass.”

Note: It is policy to use metric units of measurement in publications; however, recommendations received by NCWM technical committees and regional weights and measures associations have been printed in this publication as submitted. Therefore, the report may contain references to inch-pound units.

Table A
Table of Contents

Title of Content	Page NTEP D
<u>CARRY-OVER ITEMS:</u>	4
1. Add Testing Criteria to NTEP Policy U “Evaluating Electronic Indicators Submitted Separate from a Measuring Element”	4
<u>NEW ITEMS:</u>	6
2. Permanence of Markings, LMD Checklist	6
3. N.4.2.4. Wholesale Devices, 2013 NCWM S&T Committee Item 330-3	8
4. Corrections/Editorial for 2014 NCWM Publication 14	11
5. Product Families Table Addition - Dimethylether (DME)	15
<u>ADDITIONAL ITEMS AS TIME ALLOWS:</u>	16
6. Appendix D – Definitions: Remote Configuration Capability, NCWM S&T Committee Item 360-7	16
7. Identification of Certified Software	19
8. Software Protection/Security	20
9. Software Maintenance and Reconfiguration	24
10. LNG Metering Applications	27
<hr/>	
<u>Appendices</u>	
Appendix A — Checklist for Testing Electronic Digital Indicators with Simulated Inputs (Agenda Item 1) ..	D / A1
Appendix B — Permanence of Markings, LMD Checklist (Agenda Item 2)	D / B1
Appendix C — Excerpt from NCWM Specifications and Tolerances Committee 2013 Annual Report, Item 330-3 (Agenda Item 3).....	D / C1
Appendix D — Product Families Table, NTEP Technical Policy C – Units for Viscosity (Agenda Item 4a)	D / D1
Appendix E — Permanence of Markings, LMD Checklist (Agenda Item 4b)	D / E1
Appendix F — Proposed Additions to the Additional Checklists and Test Procedures for Cash-Activated RMFDs (Agenda Item 4c).....	D / F1
Appendix G — Proposed Changes to the ECR Interfaced with RMFDs Checklist (Agenda Item 4e)	D / G1

Table B			
Glossary of Acronyms and Terms			
CC	Certificate of Conformance	OIML	International Organization of Legal Metrology
DMS	Division of Measurement Standards	OWM	Office of Weights and Measures (NIST)
ECR	Electronic Cash Register	PD	Positive Displacement
HB 44	NIST Handbook 44 “Specifications, Tolerances, and Other Technical Requirements for Weighing and Measuring Devices”	Pub 14	NCWM Publication 14
LMD	Liquid Measuring Devices	RMFD	Retail Motor-Fuel Dispenser
mA	milliamp	SI	International System of Units
NCWM	National Conference on Weights and Measures	S&T	Specifications and Tolerances
NIST	National Institute of Standards and Technology	VTM	Vehicle Tank Meter
NTEP	National Type Evaluation Program	W&M	Weights and Measures
NTETC	National Type Evaluation Technical Committee		
This glossary is meant to assist the reader in the identification of acronyms used in this agenda and does not imply that these terms are used solely to identify these organizations or technical topics.			

Technical Advisor’s Note: I was unable to attend the Sector meeting due to a Federal Government shutdown. I want to extend thanks to Sector Chairman, Mr. Mike Keilty, and Sector Member, Mr. Paul Glowacki, for providing notes from the meeting and enabling me to prepare this summary.

Details of All Items
(In order by Reference Key)

Carry-Over Items:

1. Add Testing Criteria to NTEP Policy U “Evaluating Electronic Indicators Submitted Separate from a Measuring Element”

Source:

California NTEP Lab

Background: At its 2007 meeting, the Measuring Sector heard that Technical Policy U in NCWM Publication 14 allows for testing an indicator separate from a measuring element. However, specific test criteria had not been developed for this practice. The Sector heard a recommendation to develop and add specific criteria for testing an indicator separate from a measuring element.

From 2007 to 2010, the California NTEP laboratory worked to develop a checklist, but had received limited input on the drafts. At the 2009 Sector meeting, Mr. Dan Reiswig provided an update to the Sector on progress to develop criteria for separate electronic indicators. He reported that the draft checklist provided to the Sector follows the general format of NCWM Publication 14 and the main test procedures are at the end of the document. At the 2010 Sector meeting, Mr. Reiswig presented a list of the areas of the checklist that specifically needed further attention and review. Attachments 1 and 2 to the Sector’s 2010 Meeting Agenda submitted by Mr. Reiswig, contain the draft checklist and proposed revisions to Technical Policy T.

At its 2011 meeting, the Sector agreed that additional work is needed to finalize the checklist. Mr. Rich Miller (FMC) volunteered to serve as Chair of the Work Group and Sector Technical Advisor, Mr. Marc Buttler (NIST, OWM), will assist as needed, and monitor progress of work. Work Group members are listed below:

Electronic Indicators Checklist Work Group	
Chair:	Rich Miller, FMC
Members:	Dmitri Karimov, Liquid Controls Mike Keilty, Endress + Hauser
Review & Comment:	Mike Frailer, MD W&M Allen Katalinic, NC DMS
Technical Advisor:	Marc Buttler, NIST, OWM
<i>Established at the October 21 - 22, 2011, Measuring Sector Meeting Technical Advisor’s Note, August 2013: Mr. Michael Frailer, Maryland Weights and Measures retired June 2013. Ms. Tina Butcher, NIST, OWM has replaced Mr. Marc Buttler, as NIST Technical Advisor.</i>	

The Work Group was asked to address the **highlighted** sections in the draft checklist from Mr. Reiswig (Attachment 1 to the Sector’s 2011 Meeting Agenda) along with the five points below and submit the finished checklist to the two lab representatives listed above for review and comment.

- 1) A minimum of 10 000 pulses must be collected. To ensure that there will be a change in the displayed indication for each pulse received, the electronic indication should be scaled such that the value of the smallest indicated division should equate to less than or equal to the value associated with one input pulse.

- 2) It is important to validate whether ± 1 pulse is an appropriate tolerance, taking into consideration applicable OIML requirements.
- 3) The number of different temperature inputs and API gravity values that would need to be tested to adequately verify the temperature compensation function of an electronic indicator must be determined. Spot checking of three random tables at three different temperatures would be adequate to verify an indicator's temperature compensation feature is functioning properly.
- 4) The Work Group should add a step in the checklist for checking multipoint calibration along with associated guidance. This guidance should emphasize the necessity of working with the manufacturer of each device in order to set up tests to properly check multipoint calibration using simulated pulses.
- 5) Addressing various different input signal formats including pulses, analog, and digital communication will be challenging. Analog (4-20 mA) input devices are to be excluded from the scope at this time. The Work Group is asked to address pulse (frequency) signals in the final version of the checklist and is asked to consider whether or not to also include digital communications.

Also at that meeting, Mr. Miller reported that FMC had a new electronic indicator with frequency input (serial communication was not part of the scope) nearing release and anticipated submitting it for evaluation by the end of 2012. He proposed using the evaluation, applying both the current standards and proposed checklist, to help refine the checklist and California volunteered to serve as the evaluating laboratory. The Sector agreed with this proposal. During that meeting, Mr. Jack Kiefert volunteered to join the Work Group.

At the 2012 Sector meeting, FMC reported that, due to a heavy backlog, the California laboratory was not available to conduct an evaluation prior to the end of January 2013. However, plans are in place for the North Carolina laboratory to conduct an evaluation sometime in December 2012. The Sector agreed to maintain the item on its agenda to allow this work to be completed.

In August 2013, Work Group Chairman, Mr. Rich Miller, informed the Technical Advisor that the North Carolina laboratory conducted an evaluation on FMC's new indicator. During the evaluation, Mr. Miller and the North Carolina laboratory evaluators reviewed the checklist and identified some suggested areas for revision.

Discussion: The Sector heard an update on the Work Group's progress.

During the meeting, Mr. John Roach (California) recommended retaining Checklist Item 2.24 under Code Reference G-S.5.7., noting that this requirement is specified in NIST Handbook 44 and Mr. Jim Truex (NTEP Director) and Mr. Dmitri Karimov (Liquid Controls) agreed that the item should not be stricken. The Sector also discussed the merits of conducting permanence tests on electronics. The following additional general questions and comments were made regarding permanence tests, including suggestions that the permanence criteria section in the proposed checklist needs additional work:

- NCWM Publication 14 specifies a 20-day permanence test on electronics (e.g., digital indicators) specified in NCWM Publication 14. Additionally, NCWM Publication 14 specifies 20- and 30-day permanence tests specified for various types of Liquid-Measuring Devices.
- For indicators that will be used in vehicle-mounted installations, vehicle-mounted permanence tests are needed.
- There is a general feeling amongst Sector members present that permanence testing is not needed for electronics unless the electronics are used in a vehicle-mounted application.
- Software updates would not necessarily require a permanence test. Note that California uses a 20-day permanence test in their evaluations of new equipment. Canada requires a permanence test on initial evaluations, but not for updates to software.
- This document only addresses electronic indicators with frequency input and, thus, does not apply to indicators such as those for mass flow meters.
- The five points listed in Mr. Reisinger's proposal may not adequately be covered in the checklist and should be reviewed.

- Will the test evaluate the form of pulse scaling? How will “edge counting” and “threshold levels” be addressed?

Mr. John Roach noted that he conducts two or three evaluations of electronic indicators per year and he requires permanence tests; however, he has not used the draft checklist. Sector members present noted that the work group primarily consisted of Mr. Rich Miller (FMC) and Mr. Allen Katalinic (North Carolina). The draft checklist was not distributed nor reviewed outside of the workgroup and Mr. Katalinic has additional comments on the most recent draft. The Sector Chairman proposed that the work group continue its work for another year, giving consideration to the Sector’s discussion and comments and bring the checklist back to the Sector at its next meeting.

Decision: The Sector concluded that additional work is needed on the checklist and agreed in a vote as follows to carry this item over to its next meeting:

Proposal: Carry this item over to the next Sector meeting and ask that the sub-group continue its work and consider the points raised in the Sector’s discussion of this item.

Yes: 8
No: 0
Result: Passed

The Sector proposed no changes to NCWM Publication 14.

New Items:

2. Permanence of Markings, LMD Checklist

Source:
NTEP Measuring Labs

Recommendation:
Modify Section 1. General in the Liquid Measuring Devices Checklist as shown in Appendix B to this summary to include specific procedures for evaluating the permanence of marking.

Background:
At the spring 2013 NTEP Laboratory meeting, the measuring labs noted that the checklist for Digital Electronic Scales of NCWM Publication 14 provides detailed information about how to test the permanence of markings on the device. The labs propose replicating this language in the LMD checklist to add clarity for manufacturers and NTEP evaluators.

Discussion:
Mr. Truex (NTEP Director) explained the proposed revisions and noted that these revisions are not new procedures; the NTEP laboratories have conducted the tests shown in Appendix B to this summary on weighing and other device types for many years. The intent was not to impose more stringent requirements, but to ensure that the permanence criteria are uniformly applied; as such, the tests should be consistent regardless of the type of device. Without specific guidelines, the application of the permanence criteria is left to the judgment of individual evaluators and can lead to unintentional inconsistencies. Mr. Truex also noted that the language in proposed Sections 1.8 and 1.9 is new, but not controversial. Mr. John Roach (California) noted that these procedures are used for all tests in California and pointed out the need to ensure consistency among evaluations. Sector members asked about corresponding Canadian methods and Mr. Dennis Beattie (Measurement Canada) noted that Canada’s methods are similar and have been for some time.

Mr. Mike Keilty (Endress + Hauser) commented that the use of “wood of a pencil” seems excessive and suggested deleting the reference. Mr. Truex noted that this criterion is already part of NCWM Publication 14; the current proposal is not to modify current permanence test requirements, but such a proposal could be considered as part of a

future proposal. Mr. Henry Oppermann (W&M Consulting) explained that the reference to the wood pencil was to prevent the use of a harsher material such as a knife or screwdriver blade.

Several Sector members expressed concern that the changes outlined in the Appendix B to this summary propose changes that address all aspects of permanence criteria for markings, not just the criteria for the permanence of lettering. For example, proposed changes include additions of criteria for the “Permanence of Attachment of Badge” and title heading for the “Location and Visibility of the Marking Information.” Mr. Rich Tucker (RL Tucker Consulting) also noted that requirements for permanence of the label are addressed in specific checklist sections and suggested that these requirements should be addressed only in the specific sections of the checklist to avoid possible conflicts.

Sector members expressed concerns that the changes to the checklist format and content to mirror corresponding permanence criteria in the weighing checklists are too extensive. The Sector considered taking time during or immediately after the meeting to review the proposal and suggest alternate changes; however, there was a feeling that there was not sufficient time to do this. Consequently, the Sector agreed to limit its consideration of the proposed changes to only address permanence of lettering.

- **Decision:** After considering proposed changes to include specific criteria for determining permanence of marking information, the Sector agreed to make only the following changes. The Sector did not accept any other changes recommended in the original proposal; the original proposal is included in Appendix B to this summary for reference. Under Section 1. General, Code Reference G-S.1. Identification, delete the second and third paragraphs that currently appear after the example for “Vehicle Tank Meters” as follows:

Vehicle Tank Meters

- Serial number is required on the meter; it is a major component of the system since it is required for the system to operate.
- Serial number is required on the indicating elements.

Equipment must be marked on a surface that is an integral part of the device, and the marking must be visible after installation. If the required information is not positioned in a visible location after installation, a duplicate, permanent identification badge must be located in a visible location after installation. A removable cover is an acceptable location for the required information only if a permanent ID badge is located elsewhere on the device.

~~The information may be on a metal or plastic plate that is attached with pop rivets, adhesive, or other means, but removable bolts or screws are not permitted. A foil or vinyl badge may be used provided that it is able to survive wear and tear, remains legible, and is difficult to remove. The printing on a foil badge must be easily readable and not easily obliterated by rubbing with a relatively soft object (e.g., the wood of a pencil.)~~

Location of the information:

- Add the following heading and text after the heading of “Required Markings” prior current checklist item 1.1:

Required Markings:

Permanence of Marking Information:

“Permanent” markings address two aspects: (1) if the markings are on a plate or badge, then the marking badge must be “permanently” attached to the device, and (2) the printed information will withstand wear and cleaning.

The identification marking must be permanent, able to survive normal wear and tear, and remain legible. If located on a metal or plastic plate or badge, it must be attached with pop rivets or adhesive, or equivalent permanent means; removable bolts or screws are not permitted. A foil badge is permitted provided that it is durable, is able to survive wear and tear, remains legible, is difficult to remove, and exhibits obvious evidence of an attempt to remove the marking

or badge. The printing on a foil badge must be easily readable and not easily obliterated by rubbing with a relatively soft object (e.g., the wood of a pencil).

Location of the information:

Permanence of Lettering:

The following test procedure shall be used to determine the permanence of the identification markings. The lettering for the markings is subjected to the following tests to simulated accelerated wear. The markings are then compared with a typical set of labels exhibiting various degrees of wear, graded from minimal effect (7) to excessive unacceptable wear (1).

Attempts are made to remove the marked information whether on a badge (plate) or on the device itself, using the following means.

- **Rub over one letter of the marking at least 20 times using an ink eraser in the same manner and force as one would normally exert while erasing an inscription written with a ball point pen.**
- **Note: For consistency of application, all NTEP labs are to use Eberhard Faber ink eraser type #110 (no longer commercially available); the Papermate Black Pearl; or the Papermate Union 110.**
- **Clean the marking or badge with the following cleaners presumed to be “readily available.”**

Marking information remains legible after following the above procedures using:

- | | | |
|-----|----------------------------------------------------|---------------------------------------------------------------------------------------|
| 1.1 | Disinfecting cleaning liquid and a damp cloth. | <input type="checkbox"/> Yes <input type="checkbox"/> No <input type="checkbox"/> N/A |
| 1.2 | “Soft” household cleaning powder and a damp cloth. | <input type="checkbox"/> Yes <input type="checkbox"/> No <input type="checkbox"/> N/A |
| 1.3 | Window cleaning fluids and a damp cloth. | <input type="checkbox"/> Yes <input type="checkbox"/> No <input type="checkbox"/> N/A |

Note: For consistency of application, NTEP labs use “409,” Bon Ami, and Windex brands of products for tests in parts 1.1, 1.2, and 1.3 respectively.

All equipment shall be clearly and permanently marked on an exterior surface that is visible after installation with the following information (prefix lettering may be initial capitals, all capitals, or all lower case):

- | | | |
|-----|----------------------------------------------------------------------|---------------------------------------------------------------------------------------|
| 1.4 | The name, initials, or trademark of the manufacturer or distributor. | <input type="checkbox"/> Yes <input type="checkbox"/> No <input type="checkbox"/> N/A |
|-----|----------------------------------------------------------------------|---------------------------------------------------------------------------------------|

[Renumber subsequent paragraphs.]

3. N.4.2.4. Wholesale Devices, 2013 NCWM S&T Committee Item 330-3

Source:

NCWM S&T Committee

Recommendation:

At the 2013 NCWM Annual Meeting, the S&T Committee requested assistance and input from the NTEP Measuring Sector on a proposal recommending changes to the requirements for special tests of wholesale meters. The Sector is asked to consider the proposals currently under consideration by the S&T Committee and to provide suggestions on how the Committee might best address the concerns expressed. Appendix C to this summary includes an excerpt from the 2013 S&T Committee’s Annual Report with full details of the item. An abbreviated synopsis of the item is included below in the “Background” information.

Background:

At the 2013 NCWM Interim and Annual Meetings, the S&T Committee considered a proposal under Item 330-3 on its agenda to modify the requirements for special tests of wholesale meters. The purpose of the proposal is to better align the special test requirements in NIST Handbook 44 with the current testing procedures, measuring practices, and technology changes while maintaining the integrity of the special test.

The “Item Under Consideration” as currently shown on S&T Committee’s agenda is as follows:

Amend paragraph N.4.2.4. as follows:

N.4.2.4. Wholesale Devices. – “Special” tests shall be made to develop the operating characteristics of a measuring system and any special associated or attached elements and accessories.

N.4.2.4.1. Special Test, Type Evaluation. – “Special” tests shall **be made during type evaluation** ~~include a test~~ at the slower of the following rates:

- (a) 20 % of the marked maximum discharge rate; or
- (b) The minimum discharge rate marked on the device.

Add a new paragraph N.4.2.4.2. as follows:

N.4.2.4.2. Special Test, Field Evaluation. – “Special” tests shall be made during field tests at or near the minimum discharge flow rate developed under the conditions of installation, but not less than the minimum discharge rate marked on the device.

In its deliberations of this item, the S&T Committee heard from the submitter, Mr. Constantine Cotsoradis (Flint Hills Resources) who noted that the current language in NIST Handbook 44 is very restrictive. Even in systems where the flow can be reduced, it is difficult to set the flow and maintain it at the target flow rate over the course of an entire test.

During the 2013 NCWM Interim Meeting, the S&T Committee heard comments expressing concern that, without a test conducted near the minimum flow rate marked on the device, an official or device owner cannot adequately assess the condition of the meter and determine if the device is being properly maintained. The official also needs to be able to verify performance at other flow rates within the range of the meter.

At the 2013 NCWM Annual Meeting, the Committee heard similar comments along with comments from NIST, OWM regarding the purpose of the special test. The Committee heard additional comments suggesting that details of testing might be better addressed in the NIST Examination Procedure Outlines. The Committee heard additional comments suggesting that details of testing might best be addressed in the NIST Examination Procedure Outlines. Mr. Karimov, speaking on behalf of the MMA, expressed concern about testing at flow rates which create pressures exceeding the rated pressure of the meter.

The Committee received the following alternate proposal from Mr. Randy Jennings (Tennessee) through the NCWM Online Comment Forum:

N.4.2.4.1. Special Test, Type Evaluation. – “Special” tests shall include a test at the slower of the following rates:

- (a) **Approximately** 20 % of the marked maximum discharge rate; or
- (b) The **approximate** minimum discharge rate marked on the device.

At the 2013 Annual Meeting, the Committee received the following alternate proposal from the submitter of the item; this proposal was also supported by Mr. Jennings.

N.4.2.4.2. Special Test, Field Evaluation. – A “Special” test shall be made during field tests at or near the minimum discharge flow rate developed under the conditions of installation, but not less than the minimum discharge rate marked on the device. Additional “Special” tests may be conducted at flow rates down to and including the maximum discharge rate marked on the device.

Given the wide range of questions and concerns raised about the most appropriate way to address this issue, Mr. Michael Keilty (Endress + Hauser), chairman of the NTEP Measuring Sector, recommended that the item be moved to an information status. He suggested asking the Sector to review this issue and provide suggestions to the Committee on how to best address special tests on wholesale devices. This suggestion was supported by several other NCWM members as well as the S&T Committee.

Discussion:

Mr. Karimov, speaking on behalf of the MMA, summarized the item as presented by the submitter of the item. He noted that the design of many loading-rack metering systems is such that flow rate is automatically controlled; the user is not able to adjust the flow rate to the minimum flow rate marked on the meter. He also noted that the MMA has concerns that, if additional back pressure is created by artificially reducing the flow rate, system pressures may exceed the pressure ratings of the meter. Mr. Keilty noted that the Vehicle-Tank Meters Code and the Liquid-Measuring Devices Code both have “special test” tolerances which would apply to tests conducted at lower flow rates; the Mass Flow Meters Code does not have “special test” tolerances.

Mr. Dennis Beattie (Measurement Canada) commented that their officials require the owner to reprogram the system to deliver at lower flow rates so that performance can be verified at lower flow rates during official testing of the meter. Several commented that this might be difficult to do for smaller metering systems such as retail motor-fuel dispensers. The group also discussed how this requirement might apply to retail devices and how it would apply to wholesale devices.

The Sector also discussed the alternate proposal presented by Mr. Randy Jennings (Tennessee). Some members were concerned about the use of the word “maximum” and questioned whether or not this was intended to refer to a “minimum.” Concern was also expressed that the use of the word “approximate” could be problematic and may lead to inconsistent application.

Mr. Oppermann noted that weights and measures officials and service companies need to be able to conduct tests at lower flow rates as a means to assess the condition of the meter. This allows officials to ensure that the meter is being maintained properly and allows service personnel to assess how best to service equipment. Mr. Allen Katalinic (North Carolina) provided a specific example in which an operator was consistently operating the system at lower flow rates, emphasizing the need to test the system at lower flow rates.

Mr. Oppermann noted that the proposed language does not appear to require any test at lower flow rates and the group concurred with his interpretation. Given the importance of conducting tests over a range of flow rates, including tests at lower flow rates, Mr. Oppermann suggested the Sector advise the S&T Committee that the Sector does not support the proposal. This motion was seconded by Mr. Jerry Butler (North Carolina) and supported by the Sector.

Decision:

The Sector considered the proposals presented to the S&T Committee under its 2013 Agenda Item 330-3 for modifying the requirements under LMD Code Paragraph N.4.2.4. Wholesale Devices that apply to “Special Tests.” The Sector recognized the need to conduct tests at lower flow rates as a means to verify performance of the meter across its flow range and ensure proper maintenance by the device owner. The Sector does not concur with the language in either proposal being considered by the S&T Committee and agreed to forward this position to the S&T Committee.

4. Corrections/Editorial for 2014 NCWM Publication 14

Source:

NTEP Administrator

Background and Discussion:

Several changes that were recommended by the 2013 Measuring Sector and approved by the NCWM NTEP Committee were not correctly implemented in the 2013 NCWM Publication 14. These proposed changes are outlined in the following subitems. During the Sector meeting, NTEP Director, Mr. Truex, noted that these items were recommended and approved by the NTEP Committee and the proposed agenda items are an accurate description of those changes. He also noted that Appendices D, E, F, and G did not get posted with the meeting agenda and he circulated a copy of the first day of the Sector meeting.

a. Product Families Table, NTEP Technical Policy C – Units Correction

Recommendation:

Modify Technical Policy C. Product Categories and Families for Meters to correct the viscosity units for turbine meters as shown in Appendix D to this summary.

Background:

At its 2012 meeting, the Sector agreed to make changes correcting the unit labeling of all references to kinematic viscosity under the turbine meter columns of the Product Families Table in Technical Policy C to centistokes (cSt). Several changes that were recommended by the 2013 Measuring Sector and approved by the NCWM NTEP Committee were not correctly implemented in the 2013 NCWM Publication 14. This item is included to correct these inadvertent omissions.

Discussion/Decision:

The Sector reviewed the proposed changes in Appendix D and accepted the changes by consensus without additional comments.

b. LMD Checklist References for Card Activated Retail Motor-Fuel Dispensers

Recommendation:

Consolidate references to “credit- or debit-card activated” retail motor-fuel dispensers in the “Checklist and Test Procedures for Retail Motor-Fuel Dispensers” and correct references to printed receipt requirements to reflect NIST Handbook 44 language by making the following modifications:

- Delete Sections 7.18 through 7.21 and move this text (with some minor modifications to reflect current NIST Handbook 44 language) to “LMD – Additional Checklists and Test Procedures for Card-Activated Retail Motor-Fuel Dispensers” Section 40. Card-Activated Retail Motor-Fuel Dispensers.
 - Move the preamble to Sections 7.18 through 7.21. to the beginning of the “NTEP LMD Additional Checklists and Test Procedures for Card-Activated Retail Motor-Fuel Dispensers.”
 - Create a new “Code Reference G-S.5.1. Indicating and Recording Elements” under “NTEP LMD Additional Checklists and Test Procedures for Card-Activated Retail Motor-Fuel Dispensers,” and move the text currently in Sections 7.20 and 7.21 to this new code reference.
 - Create a new Code Reference heading for LMD Code paragraphs S.1.6.7. Recorded Representation and S.1.6.8. Recorded Representations for Transactions Where a Post-Delivery Discount(s) is Provided and insert text from 7.18 through 7.19., modified to reflect current NIST Handbook 44 language in this new reference.

- Delete Section 15. Card Activated Retail Motor-Fuel Dispensers, which is redundant to “LMD – Additional Checklists and Test Procedures for Card-Activated Retail Motor-Fuel Dispensers” Section 40.1 through 40.4.
- Delete Section 16. Test Methods for Card-Activated Retail Motor-Fuel Dispensers, which is redundant to “LMD – Additional Checklists and Test Procedures for Card-Activated Retail Motor-Fuel Dispensers” Section 41. Test Methods.

Attachment E to the Sector’s agenda outlined specific proposed changes to the checklist.

Discussion:

The Sector reviewed proposed changes in Attachment E to the Sector’s agenda. The Sector discussed changes in checklist item Section 40 in detail.

Decision:

The Sector concurred with the proposed changes in the document, with the exception to the proposed checklist item 40.8; the Sector also noted duplication in the paragraph numbering with two items being numbered 40.8. The Sector was concerned with inclusion of the “Yes,” “No,” and “N/A” checkboxes. The Sector agreed to strike the first item numbered “40.8;” however, the Sector agreed to retain the text in that item asking for a designation of the option(s) available for providing a receipt and incorporate that text into the previous Checklist item 40.7.

Appendix E to this meeting summary shows the final version of the proposed changes, including the revisions described above in section 40 that were adopted by the Sector.

c. LMD Checklist – Checklist and Test Procedures for Cash-Activated RMFDs

Recommendation:

Add the following new section at the end of Publication 14 LMD Checklist, Checklist and Test Procedures for Cash-Activated RMFDs to include references to receipt requirements for LMD Code paragraph S.1.6.7. as shown in Attachment F to the Sector’s meeting agenda.

Background:

In reviewing the references to printed receipt requirements in the LMD and associated checklists, the technical advisor noted that there are no references to the requirements for printed receipts in the section of the Checklist addressing Cash-Activated Dispensers. The proposed changes will make this section consistent with the sections on card-activated RMFDs and for ECRs interfaced with RMFDs.

Discussion:

The Sector reviewed proposed changes in Attachment F to the Sector’s agenda. The Sector discussed changes in checklist item Section 17 in detail.

Decision:

The Sector concurred with all changes except for the proposed Checklist item 17.11 which asked for a designation of the type(s) of receipts provided, similar to the item described in agenda item (c) above. The Sector was concerned with inclusion of the “Yes,” “No,” and “N/A” checkboxes. The Sector agreed to retain the text asking for a designation of the option(s) available for providing a receipt by moving this text to item 17.10. The Sector agreed to strike the remainder of item 17.11 and renumber subsequent checklist items.

Appendix F to this meeting summary shows the final version of the proposed changes adopted by the Sector, including the revisions to Section 17 described above.

d. LMD Checklist – Post-Delivery Discounts – Formatting Change

Recommendation:

Modify Publication 14 LMD Checklist Code Reference S.1.6.8. as follows to create separate checklist items for each piece of information required on the receipt and to include specific checklist line items for systems that are capable of providing electronic receipts.

Code Reference: S.1.6.8. Recorded Representations for Transactions Where a Post-Delivery Discount(s) is Provided

- 7.44. ~~Except for fleet sales and other price contract sales, w~~Where a post-delivery discount(s) is(are) applied, the sales receipt must provide: Yes No N/A
- ~~the total quantity, unit price, and total computed price that were displayed on the dispenser at the end of the delivery prior to any post-delivery discount(s); an itemization of the post-delivery discounts to the unit price; and the final total price of each fuel sale after all post-delivery discounts are applied~~
- 7.44.1. the product identity by name, symbol, abbreviation, or code number;
- 7.44.~~12.~~ the total quantity, unit price, and total computed price that were displayed on the dispenser at the end of the delivery prior to any post-delivery discount(s); Yes No N/A
- 7.44.~~23.~~ an itemization of the post-delivery discounts to the unit price; and Yes No N/A
- 7.44.~~34.~~ the final total price of each fuel sale after all post-delivery discounts are applied. Yes No N/A
- 7.44.5. For systems that are capable of generating electronic receipts, the customer must be given the alternative option of receiving a hard copy receipt in lieu of or in addition to the electronic receipt. Yes No N/A

Indicate the option(s) available:

- Hard-copy or Electronic**
- Hard-copy and Electronic**

Background:

The proposed change would assist NTEP laboratories in identify specific areas to be evaluated as part of reviewing the requirements for a receipt specified in NIST Handbook 44 LMD Code paragraph S.1.6.8. These changes also make this checklist item consistent with LMD Checklist item 7.19.2.

Discussion:

The Sector reviewed the recommendation above and concurred with all but Section 7.44.5., which asked for a designation of the type(s) of receipts provided, similar to the item described in agenda items (b) and (c) above. The Sector was concerned with inclusion of the “Yes,” “No,” and “N/A” checkboxes. The Sector agreed to retain the text asking for a designation of the option(s) available for providing a receipt by moving this text to immediately follow item 7.44.4. The Sector agreed to strike the remainder of Item 7.44.5.

Decision:

The Sector agreed to recommend the following changes for inclusion in NCWM Publication 14:

Code Reference: S.1.6.8. Recorded Representations for Transactions Where a Post-Delivery Discount(s) is Provided

7.44. ~~Except for fleet sales and other price contract sales, w~~Where a post-delivery discount(s) is(are) applied, the sales receipt must provide: Yes No N/A

~~the total quantity, unit price, and total computed price that were displayed on the dispenser at the end of the delivery prior to any post-delivery discount(s); an itemization of the post-delivery discounts to the unit price; and the final total price of each fuel sale after all post-delivery discounts are applied~~

7.44.1. the product identity by name, symbol, abbreviation, or code number:

7.44.~~12~~. the total quantity, unit price, and total computed price that were displayed on the dispenser at the end of the delivery prior to any post-delivery discount(s); Yes No N/A

7.44.~~23~~. an itemization of the post-delivery discounts to the unit price; and Yes No N/A

7.44.~~34~~. the final total price of each fuel sale after all post-delivery discounts are applied. Yes No N/A

Indicate the option(s) available for providing a receipt:

Hard Copy or Electronic

Hard Copy and Electronic

e. ECRs Interfaced with RMFDs Checklist, Section 3. Recorded Representations

Recommendation:

Modify the ECRs Interfaced with RMFDs checklist to:

- Make changes to the preamble and other text to be consistent with corresponding requirements for card- and cash-activated RMFDs;
- Add specific references to receipt requirements specified by LMD Code paragraph S.1.6.7, including the option of an electronic receipt;
- Create individual numbered checklist items for each of the three sub-bullets under the requirements for post-delivery discount receipts as specified in LMD Code paragraph S.1.6.8.; and
- Reorganize the order of items by moving the references to paragraph S.1.6.8. to follow those for S.1.6.7.

Specific proposed changes are outlined in Attachment G.

Background:

The proposed changes are to ensure consistency with corresponding changes in corresponding sections of the LMD checklist for RMFDs.

Discussion:

The Sector reviewed proposed changes in Attachment G to the Sector's agenda. The Sector discussed changes in Checklist item Section 3.2 in detail.

Decision:

The Sector concurred with all changes except for the proposed Checklist item 3.2, which asked for a designation of the type(s) of receipts provided, similar to the item described in agenda items (b), (c), and (d) above. The Sector was concerned with inclusion of the “Yes,” “No,” and “N/A” checkboxes. The Sector agreed to retain the text asking for a designation of the option(s) available for providing a receipt by moving this text to item 3.1. The Sector agreed to strike the remainder of item 3.2 and renumber subsequent checklist items.

Appendix G to this meeting summary shows the final version of the proposed changes adopted by the Sector, including the revisions to section 3 described above.

5. Product Families Table Addition - Dimethylether (DME)

Source:

Mr. John Roach (California NTEP Laboratory)

Background:

NTEP has received requests to evaluate metering systems for Dimethylether (DME), which is not currently referenced in the Product Families Table of NCWM Publication 14. The California NTEP laboratory reports the following regarding this product:

- DME seems to have similar characteristics of propane.
- CA has one client that has an LPG (propane) RMFD which is approved for several different PD meters. PD meters are viscosity sensitive in cP centipoise.
- NCWM Publication 14 states that Propane is 0.098 cP at 60 °F.
- DME is not currently referenced in the Pub 14 and it should be added.
- This product may be very popular.
- CA DMS chemists note that DME is being used in other counties for fuel and cooking. You can fill a propane container just like propane with DME.
- The submitting manufacturer provided the following data regarding DME along with relative values for Commercial Propane:
 - Liquid specific gravity at 60 ° = 0.66 Propane = 0.510
 - Vapor specific gravity at 60 °F = 1.59 Propane = 1.5
 - Centipose viscosity at 60 °F = 0.15 Propane = 0.11

Because this is the first NTEP evaluation of this product and this will set a precedent for how to address this product with regard to any resulting Certificate and its associated coverage, the California NTEP laboratory wants to ensure that adequate testing is conducted. The California Laboratory has informed the applicant that testing will need to be conducted with DME as well as LPG product unless the Measuring Sector and NTEP Committee determine otherwise. However, the question has been posed of whether or not the testing with both products is necessary.

Recommendation:

The California NTEP laboratory has asked that the Measuring Sector review the properties of this product; determine where it best fits within the Product Families Table of NCWM Publication 14; identify required testing parameters; and provide any additional guidelines for evaluating laboratories and manufacturers regarding the NTEP evaluation of meters used in this application.

Discussion:

Mr. John Roach (California) introduced the item and summarized the intent of the recommendation, noting that he is attempting to get clarification on the criteria based upon questions raised by a dispenser manufacturer. Mr. Jim Truex (NTEP Director) noted that the NTEP laboratories are not comfortable with adding DME to the “compressed gases” category since this would allow the product to be included on a Certificate that covers this category without testing the meter with DME. Mr. Dennis Beattie (Measurement Canada) noted that compatibility of materials is a

concern and Mr. Mike Keilty (Endress + Hauser) and Mr. Dmitri Karimov (Liquid Controls) gave examples of materials that are and are not compatible with DME.

Mr. Roach asked the Sector to consider whether a test is needed on a meter delivering DME in addition to testing with another product(s) in the compressed gases category. He also asked whether testing could be run on the same meter with a different meter factor. He noted that he believes a permanence test should be conducted.

Though acknowledging that the chemical properties of DME appear similar to propane, Sector members present did not have in-depth experience with DME nor specific data to illustrate similarity of meter performance with the two products.

Mr. Henry Oppermann (Weights & Measures Consulting) noted that there are three facets of this issue that need to be addressed and the Sector agreed with this analysis of the issues to be addressed:

- (1) Conducting type evaluation on a dispenser metering DME to gain a type approval for DME only.
- (2) Conducting tests on a dispenser using DME and then using propane to obtain type approval on both products. Submitting this data to the Measuring Sector in an effort to possibly obtain broader coverage of different types of meters by getting a change to the product families criteria.
- (3) Considering the need to re-open the discussion to further define the product families criteria by identifying the important product characteristics that defines the product category for each meter type. The material compatibility of the meters should not be a W&M issue; the manufacturer must ensure that the materials are appropriate for each product measured by the meter.

Decision:

The Sector considered whether or not DME can be added to a Certificate that has been issued to a meter based on testing conducted with commercial propane. The Sector acknowledged that the properties of DME may be similar to that of commercial propane; however, the Sector agreed that, if a Certificate has been issued based on testing with propane, additional testing is needed with DME in order to add DME to the Certificate. If a meter is only tested with DME, then the resulting Certificate will apply only to DME. If data is provided from NTEP testing of a meter using both propane and DME, the Sector is amenable to further considering whether or not it might be appropriate to include the chemical DME in the “Compressed Liquids” category of the Product Families Table. However, the Sector does not plan to undertake an effort to collect such data.

Additional Items as Time Allows:

If time permits, the NCWM S&T Committee and the NTEP Software Sector would appreciate input from the Measuring Sector on the measuring-related issues that are outlined in the remaining agenda items below. A copy of any regional association modifications or positions will be provided to the Sector when these are made available by the regions.

6. Appendix D – Definitions: Remote Configuration Capability, NCWM S&T Committee Item 360-7

Source:

2013 NCWM S&T Committee (2012 Grain Analyzer Sector Meeting Summary)

Background/Discussion:

At its 2012 meeting, the Grain Analyzer Sector agreed to forward a proposal to amend the definition of “remote configuration capability” in NIST Handbook 44 to the S&T Committee for consideration. The following changes were proposed:

remote configuration capability. – The ability to adjust a weighing or measuring device or change its sealable parameters from or through some other device that ~~is not~~ **may or may not** itself **be** necessary to the operation of the weighing or measuring device or ~~is not~~ **may or may not be** a permanent part of that device. [2.20, 2.21, 2.24, 3.30, 3.37, 5.56(a)]

(Added 1993, **Amended 20XX**)

The Sector noted in their proposal that removable digital storage devices containing the latest grain calibrations can be used in grain moisture meters (GMMs) as either data transfer devices that are not necessary to the operation of the GMM or as data storage devices which are necessary to the operation of the GMM. If removable data storage devices are necessary to the operation of the device, they are not covered by the current definition of remote configuration capability.

A USB flash drive is most likely to be used as a data transfer device. In a typical data transfer application, the USB flash drive is first connected to a computer with access to the GMM manufacturer’s web site to download the latest grain calibrations that are then stored in the USB flash drive. The USB flash drive is removed from the computer and plugged into a USB port on the GMM. The GMM is put into remote configuration mode to copy the new grain calibration data into the GMM’s internal memory. When the GMM has been returned to normal operating (measuring) mode, the USB flash drive can be removed from the GMM.

Although a Secure Digital (SD) memory card could also be used as a data transfer device, it is more likely to be used as a data storage device. In a typical “data storage device” application, the SD memory card stores the grain calibrations used on the GMM. The SD memory card must be plugged into an SD memory card connector on a GMM circuit card for the GMM to operate in measuring mode. To install new grain calibrations the GMM must be turned “off” or put into a mode in which the SD memory card can be safely removed. Either the SD memory card can be replaced with an SD memory card that has been programmed with the new grain calibrations, or the original SD memory card can be re-programmed with the new grain calibrations in much the same way as that described in the preceding paragraph to copy new grain calibrations into a USB flash drive. In either case, the SD memory card containing the new calibrations must be installed in the GMM for the GMM to operate in measuring mode. In that regard, the SD memory card (although removable) can be considered a permanent part of the GMM in that the GMM cannot operate without it.

Note: In the above example SD memory card could be any removable flash memory card such as the Secure Digital Standard-Capacity, the Secure Digital High-Capacity, the Secure Digital Extended-Capacity, and the Secure Digital Input/Output, which combines input/output functions with data storage. These come in three form factors: the original size, the mini size, and the micro size. A Memory Stick is a removable flash memory card format launched by Sony in 1998, and is also used in general to describe the whole family of Memory Sticks. In addition to the original Memory Stick, this family includes the Memory Stick PRO, the Memory Stick Duo, the Memory Stick PRO Duo, the Memory Stick Micro, and the Memory Stick PRO-HG.

During its Open Hearings at the 2013 NCWM Interim Meeting, the Committee heard comments from Ms. Juana Williams (NIST, OWM). OWM suggested the Committee consider this item as a Developing item to allow other Sectors to discuss how a change to the definition may affect other device types of similar design and to consider changes if needed. OWM recognizes that the current definition for “remote configuration capability” may not address those grain moisture meters (GMMs) which can only be operated with a removable data storage device, containing, among other things, the grain calibrations intended for use with the GMM, inserted in the device (as was described by the Grain Analyzer Sector). As such, OWM noted that current sealing requirements were developed at a time when such technology likely didn’t exist, nor could be envisioned, and are based on the current definition of remote configuration capability. Because the current definition was never intended to apply to this “next generation” technology, OWM suggested that those charged with further development of this item may wish to revisit the five philosophies of sealing and consider whether a new paragraph, completely separate from current sealing requirements, might be appropriate and a better option, than the one currently proposed. The five philosophies of sealing are included in the 1992 *Report of the 77th National Conference on Weights and Measures* (Report of the Specifications and Tolerances Committee). Another option, preferred over the changes currently proposed, would be to add a separate statement to the current definition of “remote configuration capability” to

address removable storage devices. For example, the following sentence might be considered as an addition to the current definition for “remote configuration capability:”

Devices which are programmed using removable media (such as SD cards, flash drives, etc.) that may or may not be required to remain with the device during normal operation are also considered to be remotely configured devices.

The Committee also heard comments from Mr. Karimov (Liquid Controls), speaking on behalf of the MMA, who made two points: (1) flow computers may already have these capabilities, thus it may be more appropriate to consider adding requirements to the General Code so that the requirements will be uniformly applied to all device types; and (2) the Committee should look ahead and consider other capabilities that may or already have emerged such as wireless communication and configuration.

The Committee acknowledged the comments indicating that the current definition of “remote configuration capability” was developed at a time when certain technologies, such as blue tooth, SD storage devices, flash drives, etc., didn’t exist. The Committee recognized that it may be difficult to modify the existing definition and associated requirements to be flexible enough to address emerging and future technologies without having a significant (and possibly detrimental impact) on existing devices. Consequently, rather than modifying the current definition, the Committee concluded that a better approach might be to develop an entirely separate set of security requirements that would apply to emerging technologies. The Committee believes that additional work is needed to develop proposed definition(s) and associated requirements and decided to designate the item as Developmental. The Committee requests other Sectors review the Grain Sector’s proposed modification to the definition as well as OWM’s suggestions and provide input.

During the 2013 NTEP Laboratory Meeting, the NTEP evaluators were asked if they were aware of or had observed during any of their evaluations of a weighing or measuring device, one which required some form of memory card or data storage device be installed in order for the device to be operational in the measuring or weighing mode. A weighing representative from Measurement Canada reported that he had observed scales having flash drives (some of which were micro in size) that are sealed via physical seal that contain calibration information and possibly even the operating system stored on a card, which must remain in the device in order for the device to be operational. The U.S. NTEP evaluators (i.e., on both the weighing and measuring side) reported they had no knowledge of such technology being used in devices they had evaluated, but they also acknowledged that it could have been present without them noticing it during the evaluation process.

At the 2013 NCWM Annual Meeting, OWM reiterated comments it made at the 2013 Interim Meeting suggesting it may be appropriate to develop separate requirements to address new and future technologies that can be remotely configured with removable media. OWM indicated it plans to develop draft language and request input from the various Sectors at their upcoming meetings. Two additional comments were made in support of possibly including requirements in the General Code of NIST Handbook 44 to address newer and emerging technologies.

Additional background information relative to this item can be found in 2013 NCWM Publication 16 at:

http://www.ncwm.net/resources/dyn/files/1025938z8fff0401/_fn/2013_ST_Pub16.pdf

Recommendation:

The Sector is asked to identify the various types of removable storage media (e.g., USB flash drives, SD memory cards, etc.) currently in use with measuring equipment and explain the functionality of that media. OWM anticipates possibly using the information provided by the Sector to develop some draft proposals to amend NIST Handbook 44 to adequately address the security of the metrological significant parameters of devices using such media. Members of the Sector may wish to review NCWM Publication 14 *LMD Technical Policy, Checklists, and Technical Procedures, Appendix B Requirements for Metrological Audit Trails* prior to the Sector meeting to refresh their understanding of the various acceptable means of providing security.

Discussion:

Sector Chairman, Mr. Keilty (Endress + Hauser) introduced the item and described Endress + Hauser’s process for storing significant parameters in removable media which is part of the device and under physical security. The ensuing discussion centered largely on the definitions of the various types of devices and how removable media might be used with them. Mr. John Roach (California) noted that a removable memory stick or memory card is covered by the current definition of “remote configuration” and NTEP Director, Mr. Truex, noted that this view is consistent with that of NIST, OWM. The Sector agrees that the current language in NIST Handbook 44 addresses devices that can be adjusted using these types of removable media.

Decision:

The Sector does not support the language “may or may not be necessary” because this phrase changes the category of what is considered “remote configuration capability.” The Sector agreed that, if the card (or other removable device) needs to be a part of the measuring device for normal operation, then the card is effectively part of the device; in that case, the measuring device is a Category 1. If the card is only used for configuration or calibration and is not necessary for the operation of the measuring device, the measuring device is a Category 2. The Sector discussed whether or not additional guidance might be needed on what is covered by each sealing category; however, concluded that the definitions are adequate as currently written.

7. Identification of Certified Software

Source:

NTEP Software Sector

Background: This item originated as an attempt to answer the question “How does the field inspector know that the software running in the device is the same software evaluated and approved by the lab?” In previous meetings it was shown that the international community has addressed this issue (both WELMEC and OIML).

At the 2012 NTETC Software Sector Meeting, there was some discussion as to where the terminology regarding inextricably linking the software version or revision to the software itself belonged. The Sector recommended adding the following to NCWM Publication 14 and forward to NTETC Weighing, Measuring, and Grain Analyzer Sectors for feedback:

Identification of Certified Software:

Note: Manufacturers may choose to separate metrologically significant software from non-metrologically significant software. Separation would allow the revision of the non-metrological portion without the need for further evaluation. In addition, non-metrologically significant software may be updated on devices without breaking a seal, if so designed. Separation of software requires that all software modules (programs, subroutines, objects etc.) that perform metrologically significant functions or that contain metrologically significant data domains form the metrologically significant software part of a measuring instrument (device or sub-assembly). If the separation of the software is not possible or needed, then the software is metrologically significant as a whole. The conformity requirement applies to all parts and parts shall be marked according to Section G-S-X.X.

The manufacturer must describe and possibly demonstrate how the version or revision identifier is directly and inseparably linked to the metrologically significant software. Where the version revision identifier is comprised of more than one part, the manufacturer shall describe which portion represents the metrological significant software and which does not.

Recommendation:

The Software Sector is requesting feedback on the following language developed by the Software Sector in 2012 for possible future inclusion into NCWM Publication 14 Weighing Devices, DES pages 22-23, Section 3. Additional Marking Requirements – Not Built-for-Purpose Software-Based Devices:

Identification of Certified Software:

Note: Manufacturers may choose to separate metrologically significant software from non-metrologically significant software. Separation would allow the revision of the non-metrological portion without the need for

further evaluation. In addition, non-metrologically significant software may be updated on devices without breaking a seal, if so designed. Separation of software requires that all software modules (programs, subroutines, objects etc.) that perform metrologically significant functions or that contain metrologically significant data domains form the metrologically significant software part of a measuring instrument (device or sub-assembly). If the separation of the software is not possible or needed, then the software is metrologically significant as a whole. The conformity requirement applies to all parts and parts shall be marked according to Section G-S-X.X.

The manufacturer must describe and possibly demonstrate how the version or revision identifier is directly and inseparably linked to the metrologically significant software. Where the version revision identifier is comprised of more than one part, the manufacturer shall describe which portion represents the metrological significant software and which does not.

Discussion:

Sector Chairman, Mr. Mike Keilty (Endress + Hauser), introduced the item and NTEP Director, Mr. Jim Truex, and he provided additional details on the item. Mr. Truex noted that the Grain Analyzers Sector looked at the proposal and agreed to consider the proposal at greater length. Grain analyzer manufacturers also agreed to take the item to their software experts for additional input and bring any recommendations back to the Sector. Mr. Truex reported that the Weighing Sector proposed adding the two paragraphs, with the exception of the last sentence of paragraph one. Mr. Truex noted that, in the LMD checklist, the language might be considered for addition to checklist item 1.6. He also commented that questions have been raised by inspectors about how to find software that has a newer revision number than the software found in the device that the inspector is examining. While the Software Sector includes representatives from four state weights and measures programs, there are no field inspectors on the Sector.

Mr. Keilty noted that the first paragraph in the recommendation appears permissive, whereas the second appears to be a requirement. He also stated that he would like the opportunity to further consider the proposed language and to take it to his company's software engineers for review and input. Mr. Paul Glowacki (Murray Equipment) indicated he would like to do the same. Mr. Gordon Johnson (Gilbarco) commented that Gilbarco's software is not written in this way and some commented that there may be differences in firmware versus software.

Mr. Dennis Beattie (Measurement Canada) commented that it is difficult for the Software Sector to anticipate future devices given the approaches used in developing software today. He noted there is a need for the Sector to focus on future and cutting edge technology rather than be overly concerned about how potential changes might affect existing equipment. He reported that the WELMEC standards requires manufacturers to explain the numbering schemes used in their equipment, and the numbering scheme is to be identified on the type approval certificate.

Decision:

After considerable discussion of the proposed changes, the Measuring Sector rejected the recommendation to include the proposed changes in NCWM Publication 14. Measuring Sector manufacturers asked for additional time to consider the proposal and carry it back to their respective companies' software engineers for input. The Sector agreed to carry this item over to its next meeting to allow the manufacturers time to study this issue and bring back alternative(s) to consider.

8. Software Protection/Security

Source:

NTEP Software Sector

Background

The Sector agreed that NIST Handbook 44 already has audit trail and physical seal, but these may need to be enhanced.

From the WELMEC Document:

Protection against accidental or unintentional changes:

Metrologically significant software and measurement data shall be protected against accidental or unintentional changes.

Specifying Notes:

Possible reasons for accidental changes and faults are: unpredictable physical influences, effects caused by user functions and residual defects of the software even though state of the art of development techniques have been applied.

This requirement includes consideration of:

- a) Physical influences: stored measurement data shall be protected against corruption or deletion when a fault occurs or, alternatively, the fault shall be detectable.
- b) User functions: confirmation shall be demanded before deleting or changing data.
- c) Software defects: appropriate measures shall be taken to protect data from unintentional changes that could occur through incorrect program design or programming errors (e.g., plausibility checks).

Required Documentation:

The documentation should show the measures that have been taken to protect the software and data against unintentional changes.

Example of an Acceptable Solution:

- The accidental modification of software and measurement data may be checked by calculating a checksum over the relevant parts, comparing it with the nominal value and stopping if anything has been modified.
- Measurement data are not deleted without prior authorization (e.g., a dialogue statement or window asking for confirmation of deletion).
- For fault detection see also Extension I.

The Sector continued to develop a proposed checklist for NCWM Publication 14. The numbering will still need to be added. This is based roughly on R 76-2 checklist and discussions beginning as early as the October 2007 NTETC Software Sector Meeting. The information requested by this checklist is currently voluntary; however, it is recommended that applicants comply with these requests or provide specific information as to why they may not be able to comply. Based on this information, the checklist may be amended to better fit with NTEP's need for information and the applicant's ability to comply.

The California, Maryland, and Ohio laboratories agreed to use this check list on one of the next devices they have in the lab and report back to the Sector on what the problems may be. In February 2011, the North Carolina laboratory was also given a copy of the check list to try.

1. Devices with Embedded Software TYPE P (aka built for purpose)	
1.1. Declaration of the manufacturer that the software is used in a fixed hardware and software environment. AND	<input type="checkbox"/> Yes <input type="checkbox"/> No <input type="checkbox"/> N/A
1.2. Cannot be modified or uploaded by any means after securing/verification. <i>Note: It is acceptable to break the "seal" and load new software, audit trail is also a sufficient seal.</i>	<input type="checkbox"/> Yes <input type="checkbox"/> No <input type="checkbox"/> N/A
1.3 The software documentation contains:	
1.3.1. Description of all functions, designating those that are considered metrologically significant.	<input type="checkbox"/> Yes <input type="checkbox"/> No <input type="checkbox"/> N/A

1.3.2. Description of the securing means (evidence of an intervention).	<input type="checkbox"/> Yes <input type="checkbox"/> No <input type="checkbox"/> N/A
1.3.3. Software Identification, including version/revision	<input type="checkbox"/> Yes <input type="checkbox"/> No <input type="checkbox"/> N/A
1.3.4. Description how to check the actual software identification.	<input type="checkbox"/> Yes <input type="checkbox"/> No <input type="checkbox"/> N/A
1.4. The software identification is:	
1.4.1. Clearly assigned to the metrologically significant software and functions.	<input type="checkbox"/> Yes <input type="checkbox"/> No <input type="checkbox"/> N/A
1.4.2. Description how to check the actual software identification.	<input type="checkbox"/> Yes <input type="checkbox"/> No <input type="checkbox"/> N/A
1.4.3. Provided by the device as documented.	<input type="checkbox"/> Yes <input type="checkbox"/> No <input type="checkbox"/> N/A
1.4.4. Directly linked to the software itself.	<input checked="" type="checkbox"/> Yes <input type="checkbox"/> No <input type="checkbox"/> N/A
2. Personal Computers, Instruments with PC Components, and Other Instruments, Devices, Modules, and Elements with Programmable or Loadable Metrologically Significant Software TYPE U (aka not built for purpose)	
2.1. The metrologically significant software is:	
2.1.1. Documented with all relevant information. (see below for list of documents)	<input type="checkbox"/> Yes <input type="checkbox"/> No <input type="checkbox"/> N/A
2.1.2. Protected against accidental or intentional changes.	<input type="checkbox"/> Yes <input type="checkbox"/> No <input type="checkbox"/> N/A
2.2. Evidence of intervention (such as, changes, uploads, circumvention) is available until the next verification / inspection (e.g., physical seal, Checksum, Cyclical Redundancy Check (CRC) , audit trail, etc. means of security).	<input type="checkbox"/> Yes <input type="checkbox"/> No <input type="checkbox"/> N/A
3. Software with Closed Shell (no access to the operating system and/or programs possible for the user)	
3.1. Check whether there is a complete set of commands (e.g., function keys or commands via external interfaces) supplied and accompanied by short descriptions.	<input type="checkbox"/> Yes <input type="checkbox"/> No <input type="checkbox"/> N/A
3.2. Check whether the manufacturer has submitted a written declaration of the completeness of the set of commands.	<input type="checkbox"/> Yes <input type="checkbox"/> No <input type="checkbox"/> N/A
4. Operating System and/or Program(s) Accessible for the User	
4.1. Check whether a checksum or equivalent signature is generated over the machine code of the metrologically significant software (program module(s) subject to legal control Weights and Measures jurisdiction and type-specific parameters).	<input type="checkbox"/> Yes <input type="checkbox"/> No <input type="checkbox"/> N/A
4.2. Check whether the metrologically significant software will detect and act upon any unauthorized alteration of the metrologically significant software using simple software tools (e.g., text editor).	<input type="checkbox"/> Yes <input type="checkbox"/> No <input type="checkbox"/> N/A
5. Software Interface(s)	
5.1. Verify the manufacturer has documented:	
5.1.1. The program modules of the metrologically significant software are defined and separated.	<input type="checkbox"/> Yes <input type="checkbox"/> No <input type="checkbox"/> N/A
5.1.2. The protective software interface itself is part of the metrologically significant software.	<input checked="" type="checkbox"/> Yes <input type="checkbox"/> No <input type="checkbox"/> N/A
5.1.3. The functions of the metrologically significant software that can be accessed via the protective software interface.	<input type="checkbox"/> Yes <input type="checkbox"/> No <input type="checkbox"/> N/A
5.1.4. The parameters that may be exchanged via the protective software	<input type="checkbox"/> Yes <input type="checkbox"/> No <input type="checkbox"/> N/A

interface are defined.	
5.1.5. The description of the functions and parameters are conclusive and complete.	<input type="checkbox"/> Yes <input type="checkbox"/> No <input type="checkbox"/> N/A
5.1.6. There are software interface instructions for the third-party (external) application programmer.	<input type="checkbox"/> Yes <input type="checkbox"/> No <input type="checkbox"/> N/A

The Maryland laboratory had particular questions regarding 3.1. and 5.1. The information for 3.1. could be acquired from an operator’s manual, a training video, or in-person training. The items in 5.1. were confusing to the evaluators. The terminology is familiar to software developers, but not necessarily others. It was indicated that manufacturers were typically quick to return the filled out questionnaire, but he didn’t know how his laboratory was supposed to verify that it was true. Generally, the laboratories wouldn’t be expected to verify things to that level. For example, if the manufacturer states that a checksum is used to ensure integrity, the laboratories wouldn’t be expected to evaluate the algorithm used.

The intent was to see whether the manufacturer had at least considered these issues, not for evaluators to become software engineers. Perhaps a glossary or descriptive paragraphs might be added to assist the evaluators for if the manufacturer has questions for the evaluators.

OIML makes use of supplementary documents to explain the checklist they use. Below are links:
<http://www.oiml.org/publications/D/D031-e08.pdf>
<http://www.welmec.org/latest/guides/72.html>
http://www.welmec.org/fileadmin/user_files/publications/2-3.pdf

WELMEC Document 2.3 is the original source for our checklist, but it’s been significantly revised and simplified. Mr. Payne (Maryland Department of Agriculture) is going to review the other documents and come up with some suggestions for the checklist. Mr. Roach (California Division of Measurement Standards) is going to begin using the checklist. The international viewpoint is that any device running an operating system is considered to be Type U. Mr. Roach mentioned that they’re having lots of problems with “skimmers” stealing PINs. Is there some way they can detect this?

Mr. Lewis (Rice Lake Weighing Systems, Inc.) mentioned he liked Measurement Canada’s website. When answering similar questions, different pages would appear, based on answers to those questions:
<http://www.ic.gc.ca/eic/site/mc-mc.nsf/eng/lm00573.html>.

At the 2011 NTETC Software Sector Meeting, the laboratories were polled to obtain any feedback on the use of the checklist. Maryland attempted to use this checklist a few times. They had some difficulty obtaining answers from the manufacturers because the individual(s) interacting with the Maryland evaluator didn’t always have the required information on hand. More experience in using the checklist will help determine what needs to be revised. It was suggested that the checklist could be sent to manufacturers for their feedback as well, with the stipulation that it a completely voluntary exercise and purely informational at this point. The laboratories will coordinate with willing manufacturers to obtain feedback.

Work is ongoing on this item with the intent that it eventually will be incorporated as a checklist in NCWM Publication 14; again the laboratories are requested to try utilizing this checklist for any evaluations on software-based electronic devices.

The checklist has been reviewed with an eye to making its terminology clearer to laboratories. Some examples and clarifications have been added as shown in the discussion section of this item. The revised checklist will be distributed to the laboratories for additional review. Maryland and California laboratories agreed to use the checklist on a trial basis.

Over the past year, attempts to use the current checklist did not meet with many difficulties. The checklists were given to the manufacturers to fill out, and that seemed to work rather well. Minor modifications (in red above) were made to clarify certain confusing areas or eliminate redundancy.

Recommendation:

The Software Sector is recommending that each NTETC Sector consider adding the proposed software checklist (shown in the table above) to their respective and appropriate NCWM Publication 14 device checklists. Thus, the MS was asked to consider whether or not it is appropriate to add the proposed software checklist to NCWM Publication 14, and if so, to which of the checklists within NCWM Publication 14 Liquid Measuring Devices it is included (for example, LMD General, RMFD, ECR-LMD, etc.).

Discussion:

Mr. Truex (NTEP Director) introduced the item and noted that the Software Sector made this recommendation in March 2013. He reported that the Grain Analyzer Sector rejected the proposal as did the Weighing Sector. A concern on the part of the other Sectors was that these criteria could not be applied to older devices and the issue of establishing non-retroactive requirements needs to be addressed. The Sectors also noted that the proposed language is not supported by corresponding requirements in NIST Handbook 44. A question was raised about Checklist Item 1.2., which implies that it is not permissible to load any metrological or non-metrological software without breaking a seal. Additionally, some terms such as “fixed software” and “software environment” were not defined and there was confusion about other terminology. There was general lack of understanding of the proposed requirements and many present were unable to see the direction in which the proposed changes were heading.

Mr. Gordon Johnson (Gilbarco) questioned whether or not there are concerns about the need for evaluator training. Mr. Dennis Beattie (Measurement Canada) pointed out that these requirements are a very small subset of the WELMEC requirements referenced. He also suggested that the issue of retroactivity be addressed first; he noted that Measurement Canada is working on a non-retroactive bulletin that will be based on WELMEC 7.2 and the manufacturer will be required to demonstrate that the device minimizes the ability for fraud. Mr. Truex stated that NTEP does not plan to go forward with software testing and evaluation directly.

Mr. John Roach (California Division of Measurement Standards) and Mr. Allen Katalinic (North Carolina) suggested that the Sector consider taking a small step of putting something into NCWM Publication 14 as a starting point. Although the Sector discussed this item at length, the Sector was unable to reach agreement on any proposed language and noted that many present did not feel they had the expertise to speak on the issue of software attributes.

Decision:

After considerable discussion and debate on the proposed changes, the Measuring Sector rejected the recommendation to include the proposed changes in NCWM Publication 14. Measuring Sector manufacturers were unable to add any contributions during the meeting that would lead to agreement to include the proposed changes in NCWM Publication 14, citing a lack of expertise to make an informed proposal or decision. However, the manufacturers committed to the task of taking this issue to their companies’ software engineers to flesh out the proposal. The Sector agreed to carry this item over to its next meeting to allow the manufacturers time to study this issue and bring back alternative(s) to consider.

9. Software Maintenance and Reconfiguration

Source:

NTEP Software Sector

Background:

After the software is completed, what do the manufacturers use to secure their software? The following items were reviewed by the Sector. *Note: Agenda Item 3 also contains information on Verified and Traced updates and Software Log.*

1. Verify that the update process is documented. (OK)
2. For traced updates, installed Software is authenticated and checked for integrity.

Technical means shall be employed to guarantee the authenticity of the loaded software (i.e., that it originates from the owner of the type approval certificate). This can be accomplished (e.g., by cryptographic means like

signing). The signature is checked during loading. If the loaded software fails this test, the instrument shall discard it and either use the previous version of the software **or become inoperative.**

Technical means shall be employed to guarantee the integrity of the loaded software (i.e., that it has not been inadmissibly changed before loading). This can be accomplished for example, by adding a checksum or hash code of the loaded software and verifying it during the loading procedure. If the loaded software fails this test, the instrument shall discard it and either use the previous version of the software **or become inoperative.** Examples are not limiting or exclusive.

3. Verify that the sealing requirements are met.

The Sector asked, “What sealing requirements are we talking about?”

This item is **only** addressing the **software update**, it can be either verified or traced. It is possible that there are two different security means, one for protecting software updates (software log) and one for protecting the other metrological parameters (Category I, II, or III method of sealing). Some examples provided by the Sector members include but are not limited to:

- Physical seal, software log
- Category III method of sealing can contain both means of security

4. Verify that if the upgrade process fails, the device is inoperable or the original software is restored.

The question before the group is, “Can this be made mandatory?”

The manufacturer shall ensure by appropriate technical means (e.g., an audit trail) that traced updates of metrologically significant software are adequately traceable within the instrument for subsequent verification and surveillance or inspection. This requirement enables inspection authorities, which are responsible for the metrological surveillance of legally controlled instruments, to back-trace traced updates of metrologically significant software over an adequate period of time (that depends on national legislation). The statement in italics will need to be reworded to comply with U.S. weights and measures requirements.

The Sector **agreed** that the two definitions below for Verified update and Traced update were acceptable.

Verified Update

A verified update is the process of installing new software where the security is broken and the device must be re-verified. Checking for authenticity and integrity is the responsibility of the owner/user.

Traced Update

A traced update is the process of installing new software where the software is automatically checked for authenticity and integrity, and the update is recorded in a software update log or audit trail.

Note: It's possible that the Philosophy of Sealing section of NCWM Publication 14 may already address the above IF the definitions of Verified and Traced Updates (and the statement below) were to be added. The contrary argument was that it may be better to be explicit).

Use of a Category 3 audit trail is required for a Traced Update. A log entry representing a traced software update shall include the software identification of the newly installed version.

The Sector recommended consolidating the definitions with the above statement thus:

Verified Update

A verified update is the process of installing new software where the security is broken and the device must be re-verified. Checking for authenticity and integrity is the responsibility of the owner/user.

Traced Update

A traced update is the process of installing new software where the software is automatically checked for authenticity and integrity, and the update is recorded in a ~~software update log or~~ Category 3 audit trail. The audit trail entry shall include the software identification of the newly installed version.

In 2012, the Sector recommended that as a first step, the following be added to NCWM Publication 14:

The updating of metrologically significant software, including software that checks the authenticity and integrity of the updates, shall be considered a sealable event.

Mr. Truex (NTEP Administrator) indicated his opinion that the above sentence is unnecessary since it's self-evident. It was agreed by the group, however, to ask the other Sectors for feedback on the value of this addition. Though the Sector is currently considering only the single sentence be incorporated into NCWM Publication 14 for the time being, ultimately, the Sector may wish to advance the remaining language of the original item submission.

Discussion:

The Sector had no information indicating that the other Sectors had yet been approached for feedback on the value of the addition of the proposed sentence.

Recommendation:

The Software Sector is requesting each of the NTETC Sectors review and provide feedback on the following draft language it developed for consideration of adding it to NCWM Publication 14:

The updating of metrologically significant software, including software that checks the authenticity and integrity of the updates, shall be considered a sealable event.

Should the MS agree this language is appropriate, it might then consider where within NCWM Publication 14 Liquid-Measuring Devices this sentence should be inserted. The Sector might consider including it in the appropriate sealing sections of Publication 14 relating to auditing trails. For example:

- LMD Checklist:
 - General, Section 2. Graduations, Indications and Recorded Representations, Code Reference G-S.8.
 - RMFDs, Section 9. Measuring Elements, Code Reference S.2.2. Provision for Sealing and Code Reference: S.2.2.1. Multiple Measuring Devices with a Single Provision for Sealing
 - Wholesale and Loading Rack Meters, Section 19. Measuring Elements, Code Reference S.2.2. Provision for Sealing and Code Reference: S.2.7.3. Provision for Sealing - Automatic Temperature Compensation
 - Vehicle-Tank Meters, Section 26. Measuring Elements, Code Reference S.2.2. Provision for Sealing and Code Reference: S.2.6.2. Provision for Sealing
 - LPG and NH3 Meters, Section 31. Measuring Elements, Code Reference S.2.2. Provision for Sealing
 - Mass Flow Meters, Section 36. Measuring Elements, Code Reference: S.3.5. Provision for Sealing
 - Water Meters Checklist, Section 45 Measuring Elements, Code Reference: S.2.1. Provision for Sealing
 - Hydrogen Gas Measuring Devices, Section 51. Design of Measuring Elements and Measuring Systems, Code Reference: S.3.3. Provision for Sealing
 - LMD Checklist Appendix B Requirements for Metrological Audit Trails
- ECR-LMD Checklist
 - Section 4. Provisions for Sealing, Code Reference: G-S.8. Provision for Sealing Electronic Adjustable Components

The Software Sector is also requesting feedback from the other NTETC Sectors regarding whether or not additional language such as the following is needed in NCWM Publication 14 to make clear that an existing audit trail should be protected during a software update. In the background information provided for this item, it was noted that the Software Sector noted that this does already seem to be addressed in the Requirements for Metrological Audit Trails.

1. The audit trail data shall be:
 - 3.5.1.1.1. Stored in non-volatile memory and shall be retained for at least 30 days if power is removed from the device. **AND**
 - 3.5.1.1.2. Protected from unauthorized erasure, substitution, or modification.

Discussion:

Mr. Truex (NTEP Director) described feedback from the Weighing Sector and Grain Sectors in their discussions of this item. Mr. Beattie (Measurement Canada) noted that the software described in the recommendation policies the authenticity of the existing software in an electronic weighing or measuring system. This software would be separate from audit trail information and the event of a change in software would be considered a metrologically significant event. In discussing this item, some members noted that there are no NIST Handbook 44 requirements to support the language proposed for inclusion in NCWM Publication 14.

Decision:

The Measuring Sector rejected the recommendation to include the proposed changes in NCWM Publication 14. Measuring Sector manufacturers were unable to add any contributions during the meeting that would lead to agreement to include the proposed changes in NCWM Publication 14; however, they committed to the task of taking this issue to their companies' software engineers to flesh out the proposal. The Sector agreed to carry this item over to its next meeting to allow the manufacturers time to study this issue and bring back alternative(s) to consider.

10. LNG Metering Applications

Source:

Michael Keilty, Endress + Hauser, Chairman, NTEP Measuring Sector

Background:

The number of LNG dispensing applications is growing in the United States. NIST Handbook 44 does not specifically address this application and many questions have come up regarding the requirements for metering devices at both retail level and also for large capacity and wholesale applications. Likewise, there are many questions about the appropriate testing procedures and criteria for these applications. Questions about this application have arisen within OIML R 117 discussions and Canada has a draft regulation for dispensing LNG already developed. NIST has begun reviewing proposed approaches for addressing LNG within NIST Handbook 44; however, does not have any specific proposals for consideration at this point.

Recommendation:

While there is no specific recommendation for the Sector to consider, the Sector is asked to provide input on how to best address this product in NIST Handbook 44 and NCWM Publication 14 as well as for suggestions on proposed testing criteria. Additional information may be provided by Mr. Keilty at the Sector Meeting.

Discussion:

Mr. Keilty introduced this item and noted related work taking place as part of an OIML project on OIML R 117-2. Mr. Beattie described some changes that Canada plans to propose to R 117-1 relative to LNG, although he noted that these changes will not be considered until R 117-1 is open for revision. Mr. Beattie described examples of a dispensing system for LNG and the group discussed various aspects of these measuring systems, including the use of vapor return lines as opposed to venting. Mr. John Roach (California Division of Measurement Standards) reported some challenges in selecting an appropriate reference scale for use in testing these systems, noting that platform scales are not generally practical and hanging scales have seemed to work best. Mr. Roach also noted that, of the LNG systems tested under NTEP, LNG was used as the test produce in one of the systems where a vapor recovery system was used; the other three used liquid nitrogen and the liquid nitrogen was vented. He reported that draft sizes were varied and a tolerance of 1.5 % was applied. He also noted that one manufacturer wanted to use a turbine meter in the testing; in this case, he believes testing needs to be conducted at additional flow rates.

Decision:

This item was included on the Sector's agenda for information purposes only to allow the Sector to discuss some aspects of testing LNG systems. Consequently, the Sector made no decisions on this item.

Appendix D/Sub-Appendix A
National Type Evaluation Program
Checklist for Testing Electronic Digital Indicators with Simulated Inputs
(Agenda Item 1)

April 18, 2013

This checklist is used for Technical Policy U. Evaluating electronic digital indicators submitted separate from a measuring element. This section is intended for lab testing only. Is permanence necessary? If new evaluation (yes) if updating existing CC (no).

Code Reference: G-S.1. Identification

All equipment shall be clearly and permanently marked on an exterior visible surface after installation. It must contain the following information (prefix lettering may be initial capitals, all capitals, or all lower case):

- | | | |
|------|-------------------------------------------------------------------------------------------------------------------------------------------------------------------------------------------------------------------------------------------------------------------------------------------------------------------------------------------------------------------------------------------------------------------------------------------------------------------------|---------------------------------------------------------------------------------------|
| 1.1. | Name, initials, or trademark of the manufacturer. | Yes <input type="checkbox"/> No <input type="checkbox"/> N/A <input type="checkbox"/> |
| 1.2. | A model designation that positively identifies the pattern or design. The Model designation shall be prefaced by the word "Model", "Type", or "Pattern." These terms may be followed by the term "Number" or an abbreviation of that word. The abbreviation for the word "Number" shall, at a minimum, begin with the letter "N" (e.g., No or No.) The abbreviation for the word "Model" shall be "Mod" or "Mod." | Yes <input type="checkbox"/> No <input type="checkbox"/> N/A <input type="checkbox"/> |
| 1.3. | Except for not built-for-purpose, software-based devices, a nonrepetitive serial number. The serial number shall be prefaced by words, an abbreviation, or a symbol, that clearly identifies the number as the required serial number. Abbreviations for the word "Serial" shall, as a minimum, begin with the letter "S," and abbreviations for the word "Number" shall, as a minimum, begin with the letter "N" (e.g., S/N, SN, Ser. No, and S No.). | Yes <input type="checkbox"/> No <input type="checkbox"/> N/A <input type="checkbox"/> |
| 1.4. | For not built-for-purpose, software-based devices the current software version or revision designation. The version or revision identifier shall be prefaced by the word "Version" or "Revision" as appropriate and either word may be followed by the word "Number." The abbreviations for the word "Version" shall, as a minimum, begin with the letter "V." The abbreviation for the word "Number" shall, as a minimum, begin with the letter "N" (e.g., No or No.). | Yes <input type="checkbox"/> No <input type="checkbox"/> N/A <input type="checkbox"/> |

Code Reference G-S.1. (e).

- 1.5. The NTEP Certificate of Conformance (CC) Number or a corresponding CC addendum number for devices that have a CC. The number shall be prefaced by the terms “NTEP CC,” “CC,” or “Approval.” These terms may be followed by the word “Number” or an abbreviation for the Word “Number.” The abbreviation shall as a minimum begin with the letter “N” (e.g., No or No.). **Yes** **No** **N/A**

The device must have an area, either on the identification plate or on the device itself, suitable for the application of the Certificate of Conformance Number. If the area for the CC Number is not part of an identification plate, then note its intended location below and how it will be applied. Ex. May be part of W&M display screen, using the requirements of section 1.6.2

Location of CC Number if not located with the identification:

Code Reference: G-S.1.1. Location of Marking Information for Not Built-for-Purpose, Software-Based Devices Not Built-for-Purpose Devices, Software-Based

- 1.6. For not built-for-purpose, software-based devices the following shall apply:
- 1.6.1. The required information in G-S.1. Identification. (a), (b), (d), and (e) shall be permanently marked or continuously displayed on the device; or
- 1.6.2. The Certificate of Conformance (CC) Number shall be:
- permanently marked on the device; or
 - continuously displayed; or
 - accessible through an easily recognized menu and, if necessary, a submenu. Examples of menu and submenu identification include, but are not limited to “Help,” “System Identification,” “G-S.1. Identification,” or “Weights and Measures Identification.”

Note: For (1.6.2.), clear instructions for accessing the information required in G-S.1. (a), (b), and (d) shall be listed on the CC, including information necessary to identify that the software in the device is the same type that was evaluated.

AK - This is not a lab issue, this is a field requirement due to the fact that the equipment is being lab evaluated, the evaluator will not see the end use installation.

Code Reference: G-S.2. Facilitation of Fraud

This applies to all metering system indicators installed at a fixed location or vehicle tank meter applications and controlled remotely or within the device itself.

This requirement addresses the process of changing the unit price or unit prices set in a metering system. Other item fall under facilitation of fraud, needs more input
Example if Cat 3 device verify passwords and audit trail is correct....

- 1.9. The system shall prevent a change of unit price during a delivery. Yes No N/A

AK – This is not a lab issue, this is a field requirement due to the fact that the equipment is being lab evaluated, the evaluator will not see the end use installation.

Code Reference: G-S.4. Interchange or Reversal of Parts

If a metering system has parts that may be interchanged or reversed in normal field assembly, the system shall either be constructed so that reversal will not affect the accuracy of the system or the parts must be marked to indicate their proper position. For most metering devices, this applies only to the reversal of connectors of cables to peripheral devices.

If a metering system has any parts that may be interchanged or reversed in normal field assembly, the parts must either be:

- 1.13. Constructed so that reversal will not affect performance, Yes No N/A
- 1.14. Marked or keyed to indicate their proper positions. May have **multiple cable connections but not interchangeable due to different plug styles, or;** Yes No N/A
- 1.15. **Cables are connected but are not removable without breaking a seal and opening housing. (Note: may need NIST Handbook 44 requirement to cover this)** Yes No N/A

2. Indications, and Recorded Representations Look at different codes

Code Reference: G-S.5.1. Indicating and Recording Elements

Several general requirements facilitate the reading and interpretation of displayed values. Each display for quantity or total price must be appropriate in design and have sufficient capacity for particular applications to be suitable for the application. Metering devices must be capable of indicating the maximum quantity and money values that can normally be expected in a particular application.

2.1. Minimum quantity value indications.

- 2.1.1. Display is capable of 1 Yes No N/A
- 2.1.2. Display is capable of 0.1 Yes No N/A
- 2.1.3. Display is capable of 0.01 Yes No N/A
- 2.1.4. Display is capable of 0.001 Yes No N/A
- 2.1.5. Display is capable of other (fill in blank): needs comment section

2.2. Money value display. .

- 2.2.1. a. Money value is properly displayed and verify rounding Yes No N/A
 b. Verify the presents of currency symbol **i.e. dollar sign “\$” or “Dollars”** Yes No N/A

3.2. The indications must be clear, definite, and accurate.

- 2.2.1. Values must be clear, definite, and accurate Yes No N/A
- 2.2.2. Unit of measure is programmable Gallon, Liter, Pound Yes No N/A
- 2.2.2. Unit of measure is applied by permanent marking on indicator housing Yes No N/A

- 2.3. The indications must be easily read under normal operating conditions. Yes No N/A

- 2.4. Symbols for decimal points shall clearly identify the decimal position. **Yes** **No** **N/A**
 (Generally acceptable symbols are dots, small commas, or x.)
- 2.5. **The zero indication must consist of at least the following minimum indications as appropriate:**
 - 2.5.1. One digit to the left and all digits to the right of a decimal point. **Yes** **No** **N/A**
 - 2.5.2. If a decimal point is not used, at least one active decade must be displayed. **Yes** **No** **N/A**
- 2.6. Totalizer values must be accurate to the nearest minimum interval with decimal points displayed or subordinate digits adequately differentiated from others, if applicable. **Yes** **No** **N/A**

Code Reference: G-S.5.2.2. Digital Indication and Representation

Basic operating requirements for devices:

- 2.7. All digital values of like value in a system shall agree with one another. **Yes** **No** **N/A**
- 2.8. A digital value coincides with its associated analog value to the nearest minimum graduation. **Yes** **No** **N/A**
- 2.9. Digital values shall round off to the nearest minimum unit that can be indicated or recorded. **Yes** **No** **N/A**
- 2.10. When a digital zero display is provided, the zero indication shall consist of at least one digit to the left and all digits to the right of the decimal point. **Yes** **No** **N/A**

Agreement of indications shall be checked for several deliveries. The totalizer shall be checked for accuracy and agreement with individual deliveries and with other totalizers in the system.

- 2.11. All digital values of like value in a system agree with one another. **Yes** **No** **N/A**
- 2.12. Digital values coincide with associated analog values to the nearest minimum graduation. **Yes** **No** **N/A**
- 2.13. Digital values “round off” to the nearest minimum unit that can be indicated or recorded. **Yes** **No** **N/A**
- 2.14. The device totalizer shall agree with the total of the individual deliveries and with other totalizers in the system. **Yes** **No** **N/A**

Code Reference: G-S.5.2.3. Size and Character

Digits used for comparable values must be uniform in size and character, but subordinate values may be displayed in different and less prominent digits than more significant values. The latter more likely occurs on analog devices. In digital indications, the digits are usually of uniform size throughout a particular display. The size of digits may differ for different quantities, for example, the quantity and unit price digits may be smaller than the total price digits.

- 2.15.** **Yes** **No** **N/A**
- 2.16. Indications and recorded representations shall be appropriately portrayed or designated. **Yes** **No** **N/A**

Code Reference: G-S.5.2.4. Values Defined

- 2.17. Values shall be adequately defined by a sufficient number of figures, words, symbols, or combinations, which are uniformly placed so that they do not interfere with the accuracy of the reading. **Yes** **No** **N/A**

Code Reference: G-S.5.2.5. Permanence

- 2.18. Indications, or recorded representations and their defining figures, words, and symbols shall be of such character that they will not tend to easily become obliterated or illegible. What permanence quantities should be verified for electronic devices with graphical displays? **Yes** **No** **N/A**

Sub-Appendix A – Checklist for Testing Electronic Digital Indicators w/Simulated Inputs (Agenda Item 1)

Code Reference: G-S.5.3., G-S.5.3.1. Values of Graduated Intervals or Increments

- 2.19. Digital indications, and recorded representations shall be uniform in size, character, and value throughout any series. Quantity values shall be defined by the specific unit of measure in use. Yes No N/A
- 2.20. Indications shall be uniform throughout any series. Yes No N/A
- 2.21. Quantity values shall be identified by the unit of measure. Yes No N/A

Code Reference: G-S.5.4. Repeatability of Indications

The quantity measured by a device shall be repeatable within tolerance for the same indication. One condition that may create a problem is that the value of the quantity division may be large relative to the tolerance. A delivery must be within tolerance wherever the delivery is stopped within the nominal indication of the test draft. Meters that may be at the tolerance limit may be out of tolerance at an extreme limit of the nominal quantity indication.

- 2.22. When a digital indicator is tested, the delivered quantity shall be within tolerance at any point within the quantity-value division for the test draft. Yes No N/A

Code Reference: G-S.5.6. Recorded Representations

- 2.23. All recorded values shall be digital. (See also G-UR.3.3.) Yes No N/A

Code Reference: G-S.5.7. Magnified Graduations and Indications

~~2.24. Magnified indications shall conform to all requirements for graduations and indications.~~

Code Reference: G-S.6. Marking, Operational Controls, Indications, and Features

All operational controls, indications, and features shall be clearly and definitely identified. Nonfunctional keys and annunciators shall not be marked because their marking implies that the key or annunciator is functional and should be inspected or tested by the enforcement official. Keys and operator controls that are visible to a customer in a direct sale transaction shall be marked with words or symbols to the extent that they can be understood by the customer and aid in understanding the transaction. Keys that are visible only to the console operator need to be marked only to the extent that a trained operator can understand the function of each key.

- 2.25. All operational controls, indications, and features including switches, lights, displays, and push buttons shall be clearly and definitely identified. Yes No N/A
- 2.26. All dual function (multi-function) keys or controls shall be marked to clearly identify all functions. Yes No N/A
- 2.27. Non-functional controls and annunciators shall not be marked (in the graphical display example they would be dimmed etc.) Yes No N/A

Code Reference: G-S.7. Lettering, Readability

- 2.28. Required markings and instructions shall be permanent and easily read. Yes No N/A

Code Reference: G-S.8. Sealing Electronic Adjustable Components, and Provision for Sealing of Adjustable Components or Audit Trail

- 2.29. Electronic adjustable components that affect the performance of a device shall provide for an approved means of security (e.g. data change audit trail) or for physically applying a security seal. These components include the following: (1) mechanical adjustment mechanism for meters, (2) the electronic calibration factor and automatic temperature compensator for electronic meter registers, (3) selection of pressure for density correction capability and correction values, and Yes No N/A

The following philosophy and list of sealable parameters applies to provision for sealing all liquid-measuring devices.

An electronic data audit trail is a means of allowing a weights and measures inspector to review how many times any electronic adjustment, which affects the accuracy of a volume measurement has been changed. The information contained in the audit trail shall consist of a cumulative and non-destructible number (even if a power failure occurs) which increments each time any of the adjustments required to be sealed have been changed. The electronic data audit trail information shall be capable of being recalled by the official on the main display of the device.

As a minimum, devices which use an audit trail to provide security for sealable parameters shall satisfy the following criteria and shall use the format set forth in Appendix A of the checklist for Liquid-Measuring Devices.

Philosophy for Sealing Typical Features to be Sealed

Principles for Determining Features to be Sealed

The need to seal some features depends upon:

- The ease with which the feature or the selection of the feature can be used to facilitate fraud; and
- The likelihood that the use of the feature will result in fraud not being detected.

Features or functions which the operator routinely uses as part of device operation, such as setting the unit prices on dispensers and maintaining unit prices in price look-up codes stored in memory, are not sealable parameters and shall not be sealed.

If a parameter (or set of parameters) selection would result in performance that would be obviously in error, such as the selection of parameters for different countries, then it is not necessary to seal the selection of these features.

If individual device characteristics are selectable from a “menu” or a series of programming steps, then access to the “programming mode” must be sealable. (Note: If an audit trail is the only means of security, then the audit trail shall update only after at least one sealable parameter has been changed; simply accessing the sealable parameters via a menu shall not update the audit trail.)

If a physical act, such as cutting a wire is required to change a parameter setting and physically repairing the cut is required to reactivate the parameter, then this physical repair process would be considered an acceptable way to select parameters without requiring a physical seal or an audit trail.

Typical Features and Parameters to be Sealed

The following provides examples of configuration and calibration parameters that are to be sealed. The examples are provided for guidance and are not intended to cover all possible parameters.

Calibration Parameters: Calibration parameters are those parameters whose values are expected to change as a result of accuracy adjustments. Examples include the following.

1. Measuring element adjustments where linearity corrections are used (e.g., flow rate 1 and meter factor 1, flow rate 2 and meter factor 2, etc.).
2. Mass flow meter adjustments for zero adjustments (not simply setting the display to zero) and span settings.

Configuration Parameters: Configuration parameters are those parameters whose values are expected to be entered only once and not changed after all initial installation settings are made. Examples include the following.

1. Octane or other blend setting ratios
2. Temperature, pressure, density, and other sensor settings for zero, span, and offset values
3. Measurement units
4. Temperature compensation table, liquid coefficient of expansion, or compressibility factors or tables
5. Liquid density setting and allowable liquid density input range

6. Vapor pressures of liquids if used in calculations to establish the quantity
7. Meter or sensor temperature compensation factors
8. On/off status of automatic temperature, pressure, or density correction
10. Automatic or manual data input for sensors
11. Filtering constants

Liquid-Measuring Device Features and Parameters	
Typical Features or Parameters to be Sealed	Typical Features or Parameters Not Required to be Sealed
Measuring element adjustment (both mechanical and electronic)	Analog-to-digital converters
Linearity correction values	Quantity division value (display resolution)
Measurement units (e.g., gallons to liters)	Double pulse counting
Octane blend setting for retail motor-fuel dispensers	Communications
Any tables or settings accessed by the software or manually entered to establish the quantity (e.g., specific gravity, pressure, etc.)	
Density ranges	
Pulsers	
Signal pick up (magnetic or reluctance)	
Temperature probes and temperature offsets in software (S.2.5.4 VT)	
Pressure and density sensors and transducers	
Flow control setting (e.g., flow rates for slow-flow start, quantity for slow-flow start and stop)	
Temperature compensating systems (on/off)	
Differential pressure valves	
As a point of clarification, the flow control settings referenced above are those controls typically incorporated into the installations of large-capacity meters (wholesale meters). The reference does not include the point at which retail motor-fuel dispensers slow product flow during a prepaid transaction to enable the dispenser to stop at the preset amount.	

Note: The above examples of adjustments, parameters, and features to be sealed are to be considered "typical" or "normal" This list may not be all inclusive. Some parameters other than those listed, which affect the metrological performance of the device, must be sealed. If listed parameters or other parameters, which may affect the metrological function of the device, are not sealed, the manufacturer must demonstrate that all settings comply with

Sub-Appendix A – Checklist for Testing Electronic Digital Indicators w/Simulated Inputs (Agenda Item 1)

the most stringent requirements for the application of the device (i.e., the parameter does not affect compliance with Handbook 44).

Category 1 Devices (Devices with No Remote Configuration Capability):

- The device is sealed with a physical seal or it has an audit trail with two event counters (one for calibration, the second for configuration). **Yes** **No** **N/A**
- A physical seal must be applied without exposing electronics. **Yes** **No** **N/A**
- Event counters are non-resettable and have a capacity of at least 000 to 999. **Yes** **No** **N/A**
- Event counters increment appropriately. **Yes** **No** **N/A**
- The audit trail information must be capable of being retained in memory for at least 30 days while the device is without power. **Yes** **No** **N/A**
- Accessing the audit trail information for review shall be separate from the calibration mode. **Yes** **No** **N/A**
- Accessing the audit trail information must not affect the normal operation of the device. **Yes** **No** **N/A**
- Accessing the audit trail information shall not require removal of any additional parts other than normal requirements to inspect the integrity of a physical security seal. (e.g., a key to open a locked panel may be required). **Yes** **No** **N/A**

Category 2 Devices (Devices with Remote Configuration Capability but Controlled by Hardware):

- The physical hardware enabling access for remote communication must be on-site. **Yes** **No** **N/A**
- The physical hardware must be sealable with a security seal or **Yes** **No** **N/A**
- The device must be equipped with at least two event counters: one for calibration, the second for configuration parameters **Yes** **No** **N/A**
 - calibration parameters event counter
 - configuration parameters event counter
- Verify that all metrological relevant parameters are logged to Event Counter (S.2.2) **Yes** **No** **N/A**
 - Adequate provision must be made to apply a physical seal without exposing electronics. **Yes** **No** **N/A**
- Event counters are non-resettable and have a capacity of at least 000 to 999. **Yes** **No** **N/A**
- Event counters increment appropriately. **Yes** **No** **N/A**
- Event counters may be located either: **Yes** **No** **N/A**
 - at the individual measuring device or
 - at the system controller
- If the counters are located at the system controller rather than at the individual device, means must be provided to generate a hard copy of the information through an on-site device. **Yes** **No** **N/A**
- An adequate number (see table below) of event counters must be available to monitor the calibration and configuration parameters of each individual device. **Yes** **No** **N/A**
- The device must either: **Yes** **No** **N/A**
 - clearly indicate when it is in the remote configuration mode or
 - the device shall not operate while in the remote configuration mode.
- If capable of printing in the calibration mode, it must print a message that it is in the calibration mode. **Yes** **No** **N/A**

- The audit trail information must be capable of being retained in memory for at least 30 days while the device is without power. **Yes** **No** **N/A**
- The audit trail information must be readily accessible and easily read. **Yes** **No** **N/A**

Minimum Number of Counters Required		
	Minimum Counters Required for Devices Equipped with Event Counters	Minimum Event Counter(s) at System Controller
Only one type of parameter accessible (calibration or configuration)	One (1) event counter	One (1) event counter for each separately controlled device, or one (1) event counter, if changes are made simultaneously.
Both calibration and configuration parameters accessible	Two (2) event counters	Two (2) event counters for each separately controlled device, or two (2) or more event counters if changes are made to all controlled devices simultaneously.

Category 3 Devices (Devices with Unlimited Remote Configuration Capability):

Category 3 devices have virtually unlimited access to sealable parameters or access is controlled though a password.

- the device must either: **Yes** **No** **N/A**
 - Clearly indicate when it is in the remote configuration mode, or
 - The device shall not operate while in the remote configuration mode
- The device is equipped with an event logger **Yes** **No** **N/A**
- Verify that all metrological relevant parameters are logged to Audit trail (S.2.2) **Yes** **No** **N/A**
 - The event logger automatically retains the identification of the parameter changed, the date and time of the change, and the new value of the parameter. **Yes** **No** **N/A**
- Event counters are nonresettable and have a capacity of at least 000 to 999. **Yes** **No** **N/A**
- The system is designed to attach a printer, or other communications device (i.e. Ethernet, Serial Communications, USB, Wi-Fi, Bluetooth etc) which will allow an interface to a printer or allow for the creation of a digital copy (file) for future reference **Yes** **No** **N/A**
- The audit trail information must be capable of being retained in memory for at least 30 days while the device is without power. **Yes** **No** **N/A**
- The event logger must have a capacity to retain records equal to ten times the number of sealable parameters in the device, but not more than 1000 records are required. **Yes** **No** **N/A**
- The event logger drops the oldest event when the memory capacity is full and a new entry is saved. **Yes** **No** **N/A**
- Describe the method used to seal the device or access the audit trail information.

Sub-Appendix A – Checklist for Testing Electronic Digital Indicators w/Simulated Inputs (Agenda Item 1)

Code Reference: G-UR.1.1. Suitability of Equipment

A register / indicator must be properly designed and have sufficient capacity to be suitable to use in a particular application. A register / indicator must measure the appropriate characteristics of a commodity to accurately determine the quantity, , have sufficient capacity to indicate the quantity measured and the associated total price if it is a computing device. The register/ indicator must have the proper capacity to operate over the actual frequency range for the application, and the device must have a quantity division appropriate for the application.

2.24. The equipment is suitable for its intended application. **Remove?** Yes No N/A

	Compliance to this requirement is determined by the permanence test. Unless specific tests are developed this has no meaning! AK RM - Agreed
--	------------------------------------------------------------------------------------------------------------------------------------------------------------

2.26.	<p>Simulator tests: All tests shall have a minimum of 10,000 pulses applied to the device for each test. Test with a minimum of two API/Density settings. Is this appropriate for all indicator technologies PD, Mass, Mag, etc? AK RM – Yes as this is a check list for a register / indicator it shall be compatible for all measurement technologies.</p> <p>Notes, items that need to be added to table / Checklist:</p> <p>a. <u>Information needs to be added to capture different K-Factor values</u></p> <p>b. <u>All API tables to be included on certificate shall be verified</u></p> <p>c. <u>Verify extreme endpoints and a center point of each table</u></p>
-------	----------------------------------------------------------------------------------------------------------------------------------------------------------------------------------------------------------------------------------------------------------------------------------------------------------------------------------------------------------------------------------------------------------------------------------------------------------------------------------------------------------------------------------------------------------------------------------------------------------------------------------------------------------------------------------------------------------------

Product:	Meter Factor:	K Factor:	
1	Test with liquid temperature between 55 °F to 65 °F at the manufactures rated maximum frequency/pulse rate.	API Gravity/Density: Temperature:	Yes <input type="checkbox"/> No <input type="checkbox"/> N/A <input type="checkbox"/>
2	Test with liquid temperature between 55 °F to 65 °F at manufactures rated minimum frequency/pulse rate.	API Gravity/Density: Temperature:	Yes <input type="checkbox"/> No <input type="checkbox"/> N/A <input type="checkbox"/>
3	Test with liquid temperature below 35 °F at manufactures rated maximum frequency/pulse rate.	API Gravity/Density: Temperature:	Yes <input type="checkbox"/> No <input type="checkbox"/> N/A <input type="checkbox"/>
4	Test with liquid temperature below 35 °F at manufactures rated minimum frequency/pulse rate.	API Gravity/Density: Temperature:	Yes <input type="checkbox"/> No <input type="checkbox"/> N/A <input type="checkbox"/>
5	Test with liquid temperature above 100 °F at manufactures rated maximum frequency/pulse rate.	API Gravity: Temperature:	Yes <input type="checkbox"/> No <input type="checkbox"/> N/A <input type="checkbox"/>
6	Test with liquid temperature above 100 °F at manufactures rated minimum frequency/pulse rate.	API Gravity: This way or Temperature:	Yes <input type="checkbox"/> No <input type="checkbox"/> N/A <input type="checkbox"/>
7	Test with liquid temperature between 55 °F to 65 °F at the manufactures rated maximum frequency/pulse rate.	API Gravity/Density: This way Temperature:	Yes <input type="checkbox"/> No <input type="checkbox"/> N/A <input type="checkbox"/>
8	Test with liquid temperature between 55 °F to 65 °F at manufactures rated minimum frequency/pulse rate.	API Gravity/Density: Temperature:	Yes <input type="checkbox"/> No <input type="checkbox"/> N/A <input type="checkbox"/>

NTEP Committee 2014 Final Report

Appendix D – 2013 Measuring Sector Summary

Sub-Appendix A – Checklist for Testing Electronic Digital Indicators w/Simulated Inputs (Agenda Item 1)

9	Test with liquid temperature below 35 °F at manufactures rated maximum frequency/pulse rate.	API Gravity/Density: Temperature:	Yes <input type="checkbox"/> No <input type="checkbox"/> N/A <input type="checkbox"/>
10	Test with liquid temperature below 35 °F at manufactures rated minimum frequency/pulse rate.	API Gravity/Density: Temperature:	Yes <input type="checkbox"/> No <input type="checkbox"/> N/A <input type="checkbox"/>
11	Test with liquid temperature above 100 °F at manufactures rated maximum frequency/pulse rate.	API Gravity/Density: Temperature:	Yes <input type="checkbox"/> No <input type="checkbox"/> N/A <input type="checkbox"/>
12	Test with liquid temperature above 100 °F at manufactures rated minimum frequency/pulse rate.	API Gravity/Density: Temperature:	Yes <input type="checkbox"/> No <input type="checkbox"/> N/A <input type="checkbox"/>

Appendix D/Sub-Appendix B
National Type Evaluation Program
Permanence of Markings, LMD Checklist
(Agenda Item 2)

1. General

Code Reference: G-S.1. Identification

Virtually all weighing and measuring equipment must be clearly and permanently marked with, or display, the manufacturer's name or trademark, model designation, and serial number. Service station dispensers, consoles, cash registers interfaced with dispensers, retrofit computing registers, and customer card-activated terminals must all have these markings.

Marking of Serial Number:

As a practical matter, some equipment need not have a serial number. "Satellite" modules in a modular system (e.g., keyboard module and cash drawer) need not have serial numbers because they do not have any "intelligence." A serial number is required in the following circumstances:

Separate Device

A device is capable of operating as a weighing or measuring device without interfacing with or connecting to other components.

Separate Main Element

Primary indicating elements must be marked. The device is a major element in the weighing or measuring system, which means, it is metrologically significant to the operation and/or performance of the system and interfaces with different compatible main elements. Examples include the following: indicating elements, weighing elements, meter registers, meter measuring elements (vehicle tank meters and loading rack meters.)

Component

The device is a component in a system, may be used in different models of devices, and is sufficiently complex to warrant a separate evaluation and a separate CC (e.g., load cells and vapor recovery nozzles.) Such a device may or may not be placed into an enclosure with other components of the system. When installed in an enclosure, the complete device must be marked with a serial number, and the one serial number will suffice for the entire collection of components. If not placed in an enclosure with other components, the component must be marked with a serial number.

The following are examples of the application of these criteria:

Retail Motor Fuel Dispensers:

- Whole unit requires a serial number.
- Indicating elements do not require a separate serial number.
- Measuring element does not require a separate serial number.
- The measuring element is metrologically significant because it affects the operation of the system as a whole; however, it is always enclosed in a housing, which has a S/N for the whole device.

Note: A conventional nozzle on a retail motor fuel dispenser is not a sufficiently complex device to warrant a special type evaluation or a serial number. The nozzle does not affect the accuracy of the delivery. A separate requirement addresses the anti-drain valve. A vapor recovery nozzle does warrant a separate evaluation because it is a complex device, and it does have the potential to affect the accuracy of the device during the

normal operation of the device. One model of vapor recovery nozzle can be used on many models of dispensers. The proper operation of a vapor recovery nozzle and system is "important" as defined by federal regulations. Thus, it is reasonable to require a vapor recovery nozzle to be marked with a serial number.

Vehicle Tank Meters

- Serial number is required on the meter; it is a major component of the system since it is required for the system to operate.
- Serial number is required on the indicating elements.

Equipment must be marked on a surface that is an integral part of the device, and the marking must be visible after installation. If the required information is not positioned in a visible location after installation, a duplicate, permanent identification badge must be located in a visible location after installation. A removable cover is an acceptable location for the required information only if a permanent ID badge is located elsewhere on the device.

The information may be on a metal or plastic plate that is attached with pop rivets, adhesive, or other means, but removable bolts or screws are not permitted. A foil or vinyl badge may be used provided that it is able to survive wear and tear, remains legible, and is difficult to remove. The printing on a foil badge must be easily readable and not easily obliterated by rubbing with a relatively soft object (e.g., the wood of a pencil.)

Location of the information:

Required Markings:

All equipment shall be clearly and permanently marked on an exterior surface that is visible after installation with the following information (prefix lettering may be initial capitals, all capitals, or all lower case):

- 1.1. The name, initials, or trademark of the manufacturer or distributor. Yes No N/A
- 1.2. A model identifier that positively identifies the pattern or design of the device. The model identifier shall be prefaced by the word "Model," "Type," or "Pattern." These terms may be followed by the word "Number" or an abbreviation of that word. The abbreviation for the word "Number" shall, as a minimum, begin with the letter "N" (e.g., No or No.) The abbreviation for the word "Model" shall be "Mod" or "Mod." Prefix lettering may be initial capitals, all capitals, or all lower case. Yes No N/A
- 1.3. Except for equipment with no moving or electronic component parts and not built for purpose, software-based devices, a non-repetitive serial number. The serial number shall be prefaced by the words "Serial Number" or an abbreviation, or a symbol, that clearly identifies the number as the required serial number. Abbreviations for the word "Serial" shall, as a minimum, begin with the letter "S," and abbreviations for the word "Number" shall, as a minimum, begin with the letter "N" (e.g., S/N, SN, Ser. No, and S No.) Yes No N/A
- 1.4. For not built-for-purpose, software based devices the current software version designation. The version or revision identifier shall be prefaced by the word "Version" or "Revision" as appropriate and either word may be followed by the word "Number." The abbreviations for the word "Version" shall, as a minimum, begin with the letter "V." Abbreviations for the word "Revision" shall, as a minimum, begin with the letter "R." The abbreviations for the word "Number" shall, as a minimum, begin with the letter "N" (e.g., No or No.) Yes No N/A

Location and Visibility of Marking Information:

Required information shall be clearly and permanently marked on an exterior surface that is visible after installation as follows:

- 1.5. Equipment must be marked on a surface that is an integral part of the device. Yes No N/A

Location of Marking Information: _____

- 1.6. Markings must be visible after installation. If the required information is not positioned in a visible location after installation, a duplicate, permanent identification badge must be located in a visible location after installation. A removable cover is an acceptable location for the required information only if a permanent ID badge is located elsewhere on the device. Yes No N/A

Permanence of Marking Information:

“Permanent” markings address two aspects: (1) if the markings are on a plate or badge, then the marking badge must be “permanently” attached to the device, and (2) the printed information will withstand wear and cleaning.

The identification marking must be permanent, able to survive normal wear and tear, and remain legible. If located on a metal or plastic plate or badge, it must be attached with pop rivets or adhesive, or equivalent permanent means; removable bolts or screws are not permitted. A foil badge is permitted provided that it is durable, is able to survive wear and tear, remains legible, is difficult to remove, and exhibits obvious evidence of an attempt to remove the marking or badge. The printing on a foil badge must be easily readable and not easily obliterated by rubbing with a relatively soft object (e.g., the wood of a pencil).

Permanence of Attachment of Badge:

- 1.7. Attempt to remove the badge by pulling it off or prying off a metal badge that is attached using only adhesive; removal must be "difficult" at all temperatures. If the badge can be removed, it must show obvious evidence that the badge was removed. Acceptable indications are destruction of the badge by tearing, permanent and extensive wrinkling, or repeated exposure of the word "VOID" upon removal of the badge. Yes No N/A

If required markings are behind a door or panel, the manufacturer is encouraged to put a label on the outside of the device that explains where the ID information is located.

- 1.8. **If the information required by G-S.1. is placed on a badge or plate, the badge or plate must be permanently attached to the device. See criteria above for permanence of Attachment of Badge.** Yes No N/A
- 1.9. **If the markings for other than device identification required by G-S.1. is placed on badge or decal, then the badge or decal must be durable (difficult to remove at all temperatures.)** Yes No N/A

Permanence of Lettering:

The following test procedure shall be used to determine the permanence of the identification markings. The lettering for the markings is subjected to the following tests to simulated accelerated wear. The markings are then compared with a typical set of labels exhibiting various degrees of wear, graded from minimal effect (7) to excessive unacceptable wear (1).

Attempts are made to remove the marked information whether on a badge (plate) or on the device itself, using the following means.

- **Rub over one letter of the marking at least 20 times using an ink eraser in the same manner and force as one would normally exert while erasing an inscription written with a ball point pen.**
- **Note: For consistency of application, all NTEP labs use Eberhard Faber ink eraser type #110**
- **Clean the marking or badge with the following cleaners presumed to be “readily available.”**

Marking information remains legible after following the above procedures using:

- 1.10. Disinfecting cleaning liquid and a damp cloth. Yes No N/A
- 1.11. “Soft” household cleaning powder and a damp cloth. Yes No N/A
- 1.12. Window cleaning fluids and a damp cloth. Yes No N/A

Note: For consistency of application, NTEP labs use “409,” Bon Ami, and Windex brands of products for tests in parts 1.8, 1.9, and 1.10 respectively.

Code Reference: G-S.1. (e)

- 1.13. An NTEP Certificate of Conformance (CC) Number or a corresponding CC addendum number for devices that have (or will have) a CC. The number shall be prefaced by the terms “NTEP CC,” “CC,” or “Approval.” These terms may be followed by the word “Number” or an abbreviation for the word “Number.” The abbreviation for the word “Number” shall as a minimum begin with the letter “N” (e.g., No or No.) Yes No N/A

The device must have an area, either on the identification plate or on the device itself, suitable for the application of the Certificate of Conformance Number. If the area for the CC number is not part of an identification plate, then note its intended location below and how it will be applied.

- 1.13.1. Location of CC Number if not located with the identification information:

Code Reference: G-S.1.1. Location of Marking Information for Not Built-for-Purpose, Software-Based Devices

- 1.14. For not built-for-purpose, software-based devices the following shall apply:
- 1.14.1. The required information in G-S.1 Identification. (a), (b), (d), and (e) shall be permanently marked or continuously displayed on the device. **OR** Yes No N/A
- 1.14.2. The Certificate of Conformance Number shall be:

- 1.14.2.1. Permanently marked on the device. **OR** Yes No N/A
- 1.14.2.2. Continuously displayed. **OR** Yes No N/A
- 1.14.2.3. Accessible through an easily recognized menu and, if necessary, a submenu. Examples of menu and submenu identification include, but are not limited to “Help,” “System Identification,” “G S.1. Identification,” or “Weights and Measures Identification.” Yes No N/A

Note: For (1.6.2.), clear instructions for accessing the information required in G-S.1. (a), (b), and (d) shall be listed on the CC, including information necessary to identify that the software in the device is the same type that was evaluated.

- 1.15. The identification badge must be visible after installation. Yes No N/A
- 1.16. The identification badge must be permanent. Yes No N/A

THIS PAGE INTENTIONALLY LEFT BLANK

Appendix D/Sub-Appendix C
National Type Evaluation Program
Excerpt from NCWM Specifications and Tolerances Committee
2013 Annual Report
(Agenda Item 3)

330-3 I N.4.2.4. Wholesale Devices

(The status of this item was changed from Voting to Informational.)

Source:

Flint Hills Resources (2013)

Purpose:

To better align wholesale meter testing with current testing procedures, measuring practices and technology changes while maintaining the integrity of the special test.

Item Under Consideration:

Amend paragraph N.4.2.4. as follows:

N.4.2.4. Wholesale Devices. – “Special” tests shall be made to develop the operating characteristics of a measuring system and any special associated or attached elements and accessories.

N.4.2.4.1. Special Test, Type Evaluation. – “Special” tests shall **be made during type evaluation** ~~include a test~~ at the slower of the following rates:

- (a) 20 % of the marked maximum discharge rate; or
- (b) The minimum discharge rate marked on the device.

Add a new paragraph N.4.2.4.2. as follows:

N.4.2.4.2. Special Test, Field Evaluation. – “Special” tests shall be made during field tests at or **near the minimum discharge flow rate developed under the conditions of installation, but not less than the minimum discharge rate marked on the device.**

Background/Discussion:

This proposal is intended to clarify that conducting a slow flow test to the marked minimum discharge rate is required for type evaluation and testing to the minimum discharge flow rate developed under the conditions of installation for routine field inspections is appropriate. It would:

- 1) Remove the rigidity of the current language and provide for flexibility and efficiency while maintaining the requirement to test at different flow rates to determine the accuracy of a measuring system;
- 2) Differentiate between testing for type evaluation and field verification;
- 3) Reflect changes in field testing procedures, technology, and industry practices; and
- 4) Improve meter performance by establishing a meter factor for the slowest preset flow rate.

The current language is very rigid and does not take field installation conditions into consideration. It may not be possible or practicable to achieve the marked minimum discharge rate during field tests without changes to upstream equipment (valves, pumps, etc.), changing the flow computer programmed presets, or changing the idling of other fueling bays during testing.

The Code does not allow for any deviation from the “shall” test at the marked minimum discharge rate. Current loading rack systems generally do not have a discharge nozzle or other physical means downstream of the meter to control or restrict the flow rate. Today, most rely on pumps and valves upstream of the meter and preprogrammed flow rates for specific products with an assigned meter factor for each flow rate and product. The proposed change would still allow for testing at the marked minimum discharge rate when there is a discharge nozzle or other physical means in use downstream of the meter to restrict flow, but would recognize the need to vary from the marked minimum discharge rate for systems not so equipped.

The submitter notes that it is more productive to verify that the system is operating properly when used in its intended manner and set-up rather than alter the system for test-purposes and then return it to its “as-used condition.” Adjusting the system to flow at the marked minimum discharge rate by making changes to the system when that flow rate is not used introduces variables into the system not normally seen and adds little to no value.

Even if the system can achieve the marked minimum discharge rate (for example, through the use of a discharge nozzle), it is not always practical or possible to hit it exactly when testing. The variables involved with proving while multiple bays are operating at a loading rack can make achieving the target flow rate difficult. It is not really necessary to test exactly at the marked minimum flow rate to develop the operating characteristics of a meter. However, NIST Handbook 44 offers no room for deviation. Today, a wholesale meter tested “near,” but not exactly “at,” the marked minimum discharge rate is not being tested in accordance with the requirements of NIST Handbook 44. This problem may never be an issue, but it might (the history regarding the change to NIST Handbook 44 Introduction section illustrates why the language in the handbook must match the application of it in the field). Amending the current language as proposed will remove this risk, however, slight.

In the LMD Code, retail motor-fuel devices with a marked minimum flow rate are tested “at or near the marked minimum flow rate,” but are not required to be tested at exactly the marked minimum. If this is acceptable for a retail motor-fuel dispenser then it should be acceptable for a wholesale meter. The proposal would make testing more uniform and consistent among different, but similar device types.

The purpose of this proposal is not to do away with a special test, but to make the test more reasonable. The proposal would allow the integrity of the test process to be maintained while providing both industry technicians and weights and measures officials the flexibility to test the meter in a manner that is more reflective of actual field testing and device use. It is designed to test meters not at the *design* flow rate, but at the flow rate at which they are actually used. It does not preclude a weights and measures inspector from testing at the marked minimum flow rate; it just removes the mandate to conduct it at that flow rate

The submitter points out the following supporting arguments:

- The marked minimum and maximum discharge rates are design parameters, not operational parameters.
- The Mass Flow Meters Code does not require testing at the marked minimum discharge rate. It requires, at a minimum, that one test be conducted at the minimum flow rate of the installation.
- The principle of testing as used and not to the design parameters is present in other codes and testing. It exists for scales since scales are not required to be tested to their design parameters; they are only tested as set up and used. A scale may be rated at a capacity range of 100 000 lb to 200 000 lb and a scale division of 20 lb or 50 lb, but it will only be tested based on its conditions of installation regardless of how it could be used.
- NIST Handbook 44 does not require that a measuring system be tested at the marked maximum discharge rate because it recognizes the measuring system may not be able to achieve the marked maximum discharge rate due to the conditions of installation.

- There is no regulation requiring a meter to be able to discharge at its marked minimum discharge flow rate; the marked minimum discharge flow rate is a design parameter not a use requirement.
- Not all tests in the test notes section are required to be conducted in the field as is noted in NIST Handbook 44 Introduction Section S. Using the Handbook, which states: “Since some sections are designed to be applied to tests performed under laboratory conditions, it would be impractical or unrealistic to apply them to field tests. Not all tests described in the “Notes” section of the handbook are required to be performed in the field as an official test.” Based on this section, it could be argued that a “special” test is not even required; however, the submitter believes that the special test has value and is not seeking to eliminate the test entirely.

The proposal doesn’t specify the exact flow rate, but requires a test at the minimum flow rate based on the system and the establishment of a meter factor at that flow rate. The added flexibility and establishment of a meter factor during the test is important for both industry technicians and weights and measures officials.

The proposed change is similar to the recommended tests described in API Manual of Petroleum Measurement Standards (MPMS) Chapter 6.2 Loading Rack Metering Systems - “When using electronic presets with multiple flow rate configurations, the establishment of multiple meter factors may be required. This is particularly true when low flow start-up and shutdown sequences are employed to prevent system shock and static electricity generation (see API RP 2003).”

A potential argument in opposition to the proposal is that, even if the system is not being used at the marked minimum discharge rate at the time of test, it could be used later; thus, it is important to not only test as found, but as it could be used. While there is some merit to this argument, it is not consistently applied since many systems are tested as found, not as they *could be* used. There is also no incentive for a fuel terminal to not test their system as used. Further, the current practice is to set a calibration factor for all flow rates, so it is unlikely that the system would be changed after testing without additional testing and establishment of a calibration factor.

Based on comments received at its 2012 Interim Meeting, the CWMA amended the original proposal to reflect language that was applicable to field practices and current with technology. The language was also amended to maintain special tests as a requirement during type evaluation, but optional for other examinations. CWMA supported the item as amended and forwarded the item to NCWM, recommending it as a Voting Item. The proposal submitted by the CWMA is as follows:

N.4.2.4. Wholesale Devices. – “Special” tests shall be made during type evaluation to develop the operating characteristics of a measuring system and any special associated or attached elements and accessories. “Special” tests shall include a test at the slower of the following rates:

- (a) 20 % of the marked maximum discharge rate; or
- (b) The minimum discharge rate marked on the device.

N.4.2.5. Wholesale Devices; Other Tests. – **Other tests may be made during field tests at or near the minimum discharge flow rate developed under the conditions of installation for all wholesale devices.**

- (a) For devices equipped with electronic preset flow rates, tests may be conducted at any electronic preset flow rate used, including the slowest flow rate, when multiple flow rate configurations are used to deliver product.**
- (b) “Normal” applicable tolerances shall apply to tests conducted.**

U.R.3.6.4. Wholesale Devices; Electronic Preset Flow Rates – A meter factor shall be established for all electronic preset flow rates used to deliver product.

At the 2013 NCWM Interim Meeting, the Committee heard comments from Mr. Ross Andersen (retired New York) who suggested that, if the concern is that there is not enough flexibility in the reference to “20 % of the marked maximum,” the focus should be placed on modifying this reference rather than making other proposed changes. He provided alternative language for the Committee to consider. The Committee also received written and verbal comments from NIST, OWM noting that the proposed language would not consider any test conducted at lower flow rates to be “normal” tests and, therefore, such tests would be required to meet “normal” test tolerances.

OWM commented that it is important to verify the performance of a meter over the range of flow rates for which it is designed to operate. The “normal” test (as described in N.4.1. Normal Tests.) combined with a “slow flow” test (as described in N.4.2.4. Wholesale Devices) allows an inspector or serviceperson to verify the performance of a meter over the range in which it is typically used under the conditions of its installation. For positive displacement meters with single point calibration, the results of both tests can be used to determine whether or not a particular meter is providing accurate measurement over the complete range of operating speeds associated with its installation and whether the meter is in good operating condition. Product discharge rates are affected by installation particulars, (e.g., the diameter of the piping, pump speed, etc.) and these can be changed after installation, thus, affecting meter performance. For these reasons, NIST, OWM recommends the slow flow test remain a required part of an official test as was originally intended by the original submitter of this item. As a general rule, NIST, OWM recommends that test procedures considered part of an official examination of a commercial weighing or measuring device not be made elective because, as such, they create the potential for inconsistent enforcement of legal requirements amongst weights and measures jurisdictions.

The proposed new paragraph N.4.2.5. Wholesale Devices; Other Tests. allows for a test at the minimum discharge rate marked on the device but would have the effect of eliminating the application of the “Special Test” tolerance, which currently applies to the results of a test conducted at flow rates below a certain point. Since the test would no longer be considered a “Special Test,” basic tolerances (i.e., 0.3 % maintenance and 0.2 % acceptance) would apply and these tolerances are more stringent than the current “Special Test” tolerance of 0.5 % specified in NIST Handbook 44. NIST, OWM is concerned about the impact this change may have on existing in-service wholesale equipment that might currently be able to comply with the “Special Test” tolerance, but may not be able to comply if that tolerance were tightened. For example, in instances where the minimum discharge flow rate developed under the conditions of installation (i.e., the test condition specified in proposed new paragraph N.4.2.5. Wholesale Devices; Other Tests.) for a wholesale device already in service, is equivalent to the lesser of the two rates specified in N.4.2.4., the flow rate for the test, whether applying proposed paragraph N.4.2.5. or existing paragraph N.4.2.4., would be the same, yet a more stringent tolerance would apply under proposed paragraph N.4.2.5.

An additional concern is that if the parameters of the test were changed from those currently specified in (a) and (b) of paragraph N.4.2.4. to the proposed “at or near the minimum discharge flow rate developed under the conditions of installation” the change would provide device owners the latitude of being able to try and extend the service life of a meter by compensating for badly worn or otherwise defective parts simply by increasing the minimum flow rate of product through it. Although such action would constitute a violation of G-UR.4.3. Use of Adjustments, it might be very difficult for officials to recognize and enforce.

For these reasons, NIST, OWM proposed alternate language (which combines elements of the original proposal and the CWMA alternative) as a means to provide more flexibility in conducting special tests, while retaining the original intent of the special test as a tool for verifying the condition of the meter.

NIST, OWM also commented that additional work is needed to develop minimum testing requirements for equipment with multi-point calibration capability to ensure consistency in inspection and testing of these systems.

Mr. Henry Oppermann (Weights and Measures Consulting) echoed NIST, OWM’s concerns regarding the need to conduct special tests as a means to assess the condition of the meter. He acknowledged that the current language in NIST Handbook 44 may not provide the same flexibility that is provided for other meter types (for which tests can be “at or near” the marked minimum); however, he expressed concern about backing off of a proper test for what appears to be primarily convenience. Mr. Constantine Cotsoradis (Flint Hills Resources) pointed out that with many current systems; there frequently is not a way to restrict the flow rate. Mr. Richard Suiter (Richard Suiter Consulting) further commented that the location where flow is restricted (e.g., before vs. after the meter) during

special tests can also affect the results of testing, and this should be considered in constructing the final language (and associated test procedures) for any proposed change.

Mr. Dmitri Karimov (Liquid Controls Corporation, LLC), speaking on behalf of the MMA, noted that the proposal has the effect of (1) providing some flexibility in establishing a flow rate near the marked minimum flow rate rather than at the minimum; (2) changing the tolerances that would apply to tests conducted at slower flow rates; and (3) specifying the establishment of meter factors for preset flow rates. Of these three facets, MMA only supports the first. He noted that some registers may use different types of calibration factors and addressing these variations in a single paragraph would be difficult. He further noted that, if changes are made to the test conditions in the LMD Code, similar changes should be made to other measuring codes as needed to ensure consistency.

Ms. Julie Quinn (Minnesota) noted that Minnesota believes that it is necessary to conduct testing at every flow rate where the device is configured; however, the factors at these various points do not need to be different.

The Committee acknowledged the comments in support of maintaining the requirement for conducting special tests during routine field inspections, but modifying paragraph N.4.2.4. to provide for some flexibility in the rate at which a special test is conducted. In recognition of limitations which may prevent some systems from being tested exactly at the marked minimum flow rate, the Committee agreed that modification to the language to be more consistent with other measuring devices is appropriate. Based on the support heard for the language proposed by NIST, OWM with respect to N.4.2.4.1. Special Test, Type Evaluation and N.4.2.4.2. Special Tests, Field Evaluation, the Committee agreed to recommend this alternative language as shown in the Item Under Consideration above for a Vote.

In reviewing the remaining portion of the proposed changes, the Committee noted the considerable debate regarding the inclusion of the User Requirement regarding the establishment of meter factors for preset flow rates. Based on this opposition, the Committee considered splitting this proposal into two items: one item to address the proposed changes to the Notes and a second item to address the proposed changes to the User Requirements. However, there was very limited support for the proposed changes to the User Requirement. Thus, the Committee decided to eliminate the proposed paragraph U.R.3.6.4 Wholesale Devices; Electronic Preset Flow Rates from the Item Under Consideration.

At their 2013 Annual Meetings, NEWMA and the CWMA supported the item as a Voting Item and commented that they believe the concerns stated by NIST, OWM and others at the NCWM Interim meeting have been sufficiently addressed by the NCWM S&T Committee.

Two Government representatives indicated a position of support on the NCWM Online Position Forum. Another Government representative, Mr. Randy Jennings (Tennessee) indicated opposition to the proposal and, noting that the item appeared on only one regional weights and measures association agenda, expressed concern that the item requires more vetting. Mr. Jennings expressed concern about the phrase “developed under the conditions of the installation,” and noted that this may be interpreted to mean that, if a system can be installed to run at maximum flow rates other than “start-up” and “shut-down,” then an official cannot request that the system be “choked” to reduce the flow. He further commented that the reduced flow test has always been effective in detecting and diagnosing wear in the meter. He also noted that Tennessee has a valve on its prover that can be used to reduce the flow rate during a slow flow test. Mr. Jennings proposed the following alternative changes to paragraph N.4.2.4.1. Special Test, Type Evaluation which would make the current requirement less restrictive, yet achieve a compromise to help all stakeholders:

N.4.2.4.1. Special Test, Type Evaluation. – “Special” tests shall include a test at the slower of the following rates:

- (a) **Approximately** 20 % of the marked maximum discharge rate; or
- (b) The **approximate** minimum discharge rate marked on the device.

During its Open Hearings at the 2013 Annual Meeting, the Committee received a proposed modification to the Item Under Consideration by the original submitter Mr. Cotsoradis. In addition to the other changes proposed in the Item Under Consideration, Mr. Cotsoradis proposed replacing the new paragraph N.4.2.4.2. with the following:

N.4.2.4.2. Special Test, Field Evaluation. – A “Special” test shall be made during field tests at or near the minimum discharge flow rate developed under the conditions of installation, but not less than the minimum discharge rate marked on the device. Additional “Special” tests may be conducted at flow rates down to and including the maximum discharge rate marked on the device.

Mr. Jennings supported this proposed modification by Mr. Cotsoradis.

Mr. Cotsoradis further noted that the current language in NIST Handbook 44 is very restrictive. Even in systems where the flow can be reduced, it is difficult to set the flow and maintain it at the target flow rate over the course of an entire test.

NIST, OWM noted that, according to the 1949 NCWM S&T Committee Report, requirements to conduct “Special Tests” were established in 1949. The report states that “Special” tests are not defined in detail except that such tests shall include tests at specified minimum discharge rates; other details of “Special” tests are left to the judgment of the official. The primary purpose of the “Special” test is to determine the condition of the meter and determine whether or not the user is maintaining the equipment in proper operating condition. As noted in comments during the 2013 Interim Meeting, the results of a “Special” test, conducted at a slow flow rate, when compared with the result of a “Normal” test can indicate the condition of the meter. In general, the greater the difference between meter errors observed for the “Normal” and “Special” test, the stronger the indication that the meter is in need of reconditioning. It is questionable whether or not two tests conducted at flow rates that are not appreciably different will provide adequate information about the condition of a meter. If the features of a particular installation do not permit testing at the slower rates as currently required in paragraph N.4.2.4. Wholesale Devices, paragraph G-UR.4.4. Assistance in Testing Operations may be applied to facilitate a proper test. OWM also pointed out that when this requirement was first added the dominant meter technology was positive displacement meters. Since that time a number of different technologies have been developed and it may be necessary to reassess what minimum testing is necessary. OWM also noted that in training provided by NIST on testing of these systems, NIST, OWM recommends running tests at slightly above the targeted flow rate; this helps to prevent the flow rate from dropping below the meter’s marked minimum flow rate and, thus, helps to ensure a fair test of the metering system. NIST, OWM also reiterated comments it made during the 2013 Interim Meeting concerning the need to develop testing requirements for equipment with multi-point calibration capability.

Mr. Andersen suggested that the specifics of what testing is required would best be addressed in the NIST EPOs. Mr. Karimov expressed concern about testing at flow rates which create pressures exceeding the rated pressure of the meter. The Committee heard additional comments from conference members expressing confusion over what minimum testing should be required.

Mr. Michael Keilty (Endress + Hauser), chairman of the NTEP Measuring Sector, recommended that the item be moved to an information status. He suggested asking the Sector to review this issue and provide suggestions to the Committee on how to best address special tests on wholesale devices. This suggestion was supported by several other NCWM members.

The Committee agreed to ask the Measuring Sector to review and provide suggestions on this issue. Consequently, it changed the status of this item from “Voting” to “Information” to allow for additional input from the Sector and other interested parties.

Additional letters, presentations and data may have been part of the Committee’s consideration.

Appendix D/Sub-Appendix D

National Type Evaluation Program Product Families Table, NTEP Technical Policy C – Units Correction

(Agenda Item 4a)

Mass Meter Product Category and Test Requirements			Magnetic Flow Meter Product Category and Test Requirements			Positive Displacement Flow Meter Product Category and Test Requirements		Turbine Flow Meter Product Category and Test Requirements	
<p>Test B</p> <p>To cover a range of the following products, test with one product having a low specific gravity and test with a second product having a high specific gravity. The Certificate of Conformance will cover all products in all product categories listed in the table under Test B within the specific gravity range tested.</p> <ul style="list-style-type: none"> • Test B does not apply to product categories of liquefied gases, compressed liquids, cryogenic liquids or heated products. <p><i>Note: Product categories under Test B were formerly referred to collectively as “Normal Liquids.”</i></p>			<p>Test F</p> <p>To cover a range of the following products, test with one product having a specified conductivity. The Certificate of Conformance will cover all products with conductivity equal to or above the conductivity of the tested liquid.</p> <ul style="list-style-type: none"> • Test F does not apply to product categories of potable water, non-potable water, tap water, water mixes of alcohols and glycols, fertilizers, suspension fertilizers, liquid feeds, clear liquid fertilizers, chemicals or crop chemicals A, B, C, or D. • Test F does not apply to product categories of liquefied gases, or compressed liquids. 			<p>Test C</p> <p>To cover a range of products within each product category, test with one product having a low viscosity and test with a second product having a high viscosity within each category. The Certificate of Conformance will cover all products in the product category within the viscosity range tested.</p>		<p>Test E</p> <p>To cover a range of products within each product category, test with one product having a low kinematic viscosity and test with a second product having a high kinematic viscosity within each category. The Certificate of Conformance will cover all products in the product category within the kinematic viscosity range tested.¹</p>	
						<p>Product Category: Alcohols, Glycols and Water Mixes Thereof (Alc Gly)</p>		<p>Product Category: Alcohols, Glycols and Water Mixes Thereof (Alc Gly)</p>	
Typical Products	Specific Gravity ² (60 °F)	Product Category	Typical Products	Conductivity (micro-siemens/centimeter)	Product Category	Typical Products	Reference Viscosity ¹ (60 °F) centipoise (cP)	Typical Products	Reference Kinematic Viscosity ¹ (60 °F) centistokes (cSt)
Butanol	0.81	Alc Gly	Butanol		Alc Gly	Butanol	3.34	Butanol	4.13
Ethanol	0.79	Alc Gly	Ethanol	0.0013	Alc Gly	Ethanol	1.29	Ethanol	1.64
Ethylene	1.19	Alc Gly	Ethylene		Alc Gly	Ethylene Glycol	25.5	Ethylene Glycol	21.5

¹ Viscosity (dynamic) is measured in centipoise. Kinematic viscosity is measured in centistokes. Source for some of the viscosity value information is the Industry Canada – Measurement Canada "Liquid Products Group, Bulletin V-16-E (rev.1), August 3, 1999."

centistokes (10⁻⁶ m²/s) = centipoise (10⁻³ kg/m·s) ÷ density (kg/m³) OR centistokes (cSt) = 1.002 × centipoise (cP) ÷ density (SG)

² The specific gravity of a liquid is the ratio of its density to that of water at standard conditions, usually 4 °C (or 40 °F) and 1 atmosphere. The density of water at standard conditions is approximately 1000 kg/m³ (or 998 kg/m³). The specific gravity of a gas is the ratio of its density to that of air at standard conditions, usually 4 °C (or 40 °F) and one atmosphere.

Mass Meter Product Category and Test Requirements			Magnetic Flow Meter Product Category and Test Requirements			Positive Displacement Flow Meter Product Category and Test Requirements		Turbine Flow Meter Product Category and Test Requirements	
Glycol			Glycol						
Isobutyl	0.81	Alc Gly	Isobutyl	0.02	Alc Gly	Isobutyl	4.54	Isobutyl	5.62
Isopropyl	0.79	Alc Gly	Isopropyl	3.5	Alc Gly	Isopropyl	2.78	Isopropyl	3.53
Methanol	0.80	Alc Gly	Methanol	0.44	Alc Gly	Methanol	0.64	Methanol	0.80
Propylene Glycol	1.04	Alc Gly	Propylene Glycol		Alc Gly	Propylene Glycol	54	Propylene Glycol	52
Banvel	0.7 – 1.2	CC-A	6 Oil (#5, #6)		FL&O	Test C Product Category: Crop Chemicals (Type A) (CC-A)		Test E Product Category: Compressed Liquids, Fuels and Refrigerants NH ₃ (Comp liq)	
Herbicides	0.7 – 1.2	CC-A	Asphalt		FL&O	Typical Products	Reference Viscosity ¹ (60 °F) centipoise (cP)	Typical Products	Reference Kinematic Viscosity ¹ (60 °F) centistokes (cSt)
Paraquat	0.7 – 1.2	CC-A	Avgas		FL&O	Banvel	4 – 400	Anhydrous Ammonia	0.31
Typical Products	Specific Gravity ² (60 °F)	Product Category	Typical Products	Conductivity (micro-siemens/centimeter)	Product Category	Test C Product Category: Crop Chemicals (Type A) (CC-A) continued		Test E Product Category: Compressed Liquids, Fuels and Refrigerants NH ₃ (Comp liq) continued	
Prowl	0.7 – 1.2	CC-A	Biodiesel above B20		FL&O	Typical Products	Reference Viscosity ¹ (60 °F) centipoise (cP)	Typical Products	Reference Kinematic Viscosity ¹ (60 °F) centistokes (cSt)
Round-up	0.7 – 1.2	CC-A	Bunker Oil		FL&O	Herbicides	4 – 400	Butane	0.32
Touchdown	0.7 – 1.2	CC-A	Cooking Oils		FL&O	Paraquat	4 – 400	Ethane	
Treflan	0.7 – 1.2	CC-A	Corn Oil		FL&O	Prowl	4 – 400	Freon 11	0.21
Adjuvants	0.7 – 1.2	CC-B	Crude Oil		FL&O	Round-up	4 – 400	Freon 12	0.27
Fumigants	0.7 – 1.2	CC-B	Diesel Fuel ³		FL&O	Touchdown	4 – 400	Freon 22	1.46
Fungicides	0.7 – 1.2	CC-B	Fuel Oil (#1, #2, #3, #4)	0	FL&O	Treflan	4 – 400	Propane	0.195
Insecticides	0.7 – 1.2	CC-B	Gasoline ⁴		FL&O	Test C Product Category: Crop Chemicals (Type B) (CC-B)		Test E Product Category: Fuels, Lubricants, Industrial and Food Grade Liquid oils (FL&O)	
Fungicides	1 – 1.2	CC-C	Jet A		FL&O	Typical Products	Reference Viscosity ¹ (60 °F) centipoise (cP)	Typical Products	Reference Kinematic Viscosity ¹ (60 °F) centistokes (cSt)
Micronutrients	0.9 – 1.65	CC-D	Jet A-1		FL&O	Adjuvants	0.7 – 100	6 Oil (#5, #6)	73 – 14,500
Hydrochloric Acid	1.1	Chem	Jet B		FL&O	Fumigants	0.7 – 100	Asphalt	

³ Diesel fuel blends (biodiesel with up to 20 % vegetable or animal fat/oil.)

⁴ Gasoline includes oxygenated fuel blends with up to 15 % oxygenate.

Mass Meter Product Category and Test Requirements			Magnetic Flow Meter Product Category and Test Requirements			Positive Displacement Flow Meter Product Category and Test Requirements		Turbine Flow Meter Product Category and Test Requirements	
Phosphoric Acid	1.87	Chem	JP4		FL&O	Fungicides	0.7 – 100	Avgas	
Sulfuric Acid	1.83	Chem	JP5		FL&O	Insecticides	0.7 – 100	Biodiesel above B20	11.8
3-10-30	0.9 – 1.65	Fert	JP7 and JP8		FL&O	Test C Product Category: Crop Chemicals (Type C) (CC-C)		Bunker Oil	11,300
4-4-27	0.9 – 1.65	Fert	Kerosene		FL&O	Typical Products	Reference Viscosity ¹ (60 °F) centipoise (cP)	Cooking Oils	10.8
9-18-9	1.32	Fert	Light Oil		FL&O	Fungicides	20 – 900	Corn Oil	4.4
10-34-0	1.39	Fert	Lubricating Oils		FL&O	Test C Product Category: Crop Chemicals (Type D) (CC-D)		Crude Oil	3 – 2260
20 % Aqua-Ammonia	0.89	Fert	Olive Oil		FL&O	Typical Products	Reference Viscosity ¹ (60 °F) centipoise (cP)	Diesel Fuel ³	12
28 %, 30 % or 32 %	1.28 – 1.32	Fert	Peanut Oil		FL&O	Micronutrients	20 – 1000	Fuel Oil (#1, #2, #3, #4)	9 – 98

Typical Products	Specific Gravity ² (60 °F)	Product Category	Typical Products	Conductivity (micro-siemens/centimeter)	Product Category	Test C Product Category: Chemicals (Chem)		Test E Product Category: Fuels, Lubricants, Industrial and Food Grade Liquid oils (FL&O) continued	
						Typical Products	Reference Viscosity ¹ (60 °F) centipoise (cP)	Typical Products	Reference Kinematic Viscosity ¹ (60 °F) centistokes (cSt)
Ammonia Nitrate	1.16 – 1.37	Fert	SAE Grades		FL&O	Typical Products	Reference Viscosity ¹ (60 °F) centipoise (cP)	Gasoline ⁴	0.39
Clear Liquid Fertilizer	1.17 – 1.44	Fert	Soy Oil	0	FL&O	Hydrochloric Acid	0.80 – 1.0	Jet A	
Nitrogen Solution	1.17 – 1.44	Fert	Spindle Oil		FL&O	Phosphoric Acid	161	Jet A-1	1.8
N-P-K Solutions	1.2 – 1.4	Fert	Sunflower Oil		FL&O	Sulfuric Acid	1.49	Jet B	
Urea	1.89	Fert	Vegetable Oil	0	FL&O	Test C Product Category: Compressed Liquids, Fuels and Refrigerants (Comp liq)			
6 Oil (#5, #6)	0.9	FL&O	Asphalt		Heated	Typical Products	Reference Viscosity ¹ (60 °F) centipoise (cP)	JP4	1.34
Asphalt		FL&O	Bunker C		Heated	Anhydrous Ammonia	0.188	JP5	2.56
Avgas		FL&O	Carbon Tetra-Chloride		Solv Cl	Butane	0.19	JP7 and JP8	2.4
Biodiesel above B20	0.86	FL&O	Methylene-Chloride		Solv Cl	Ethane		Kerosene	2.6
Bunker Oil	0.99	FL&O	Perchloro-Ethylene		Solv Cl	Freon 11	0.313	Light Oil	15.7

Mass Meter Product Category and Test Requirements			Magnetic Flow Meter Product Category and Test Requirements			Positive Displacement Flow Meter Product Category and Test Requirements		Turbine Flow Meter Product Category and Test Requirements	
Cooking Oils	0.92	FL&O	Trichloro-Ethylene		Solv Cl	Freon 12	0.359	Lubricating Oils	22 – 1250
Corn Oil	0.91	FL&O	Acetates		Solv Gen	Freon 22	1.99	Olive Oil	127
Crude Oil	0.79 – 0.97	FL&O	Acetone	.02	Solv Gen	Propane	0.098	Peanut Oil	11 – 122
Diesel Fuel ³	0.84	FL&O	Ethylacetate	0.00001	Solv Gen	Test C Product Category: Clear Liquid Fertilizers (Fert)		SAE Grades	214 – 4037
Fuel Oil (#1, #2, #3, #4)	0.9	FL&O	Hexane	0	Solv Gen	Typical Products	Reference Viscosity¹ (60 °F) centipoise (cP)	Soy Oil	97.6
Gasoline ⁴	0.72	FL&O	MEK	0.1	Solv Gen	9-18-0		Spindle Oil	
Jet A		FL&O	Toluene	0	Solv Gen	10-34-0	48	Sunflower Oil	97.1
Jet A-1	0.76	FL&O	Xylene	0	Solv Gen	20 % Aqua-Ammonia	1.1 – 1.3	Vegetable Oil	145
Jet B		FL&O	Deionized		Water	28 %, 30 % or 32 %	31 – 110	Test E Product Category: Solvents General (Solv Gen)	
JP4	0.76	FL&O	Demineralized		Water	Ammonia Nitrate	11.22	Typical Products	Reference Kinematic Viscosity¹ (60 °F) centistokes (cSt)
JP5	0.76	FL&O				Clear Liquid Fertilizer	31 – 110	Acetates	0.47
JP7 and JP8	0.76	FL&O				Nitrogen Solution	31 – 110	Acetone	0.43
Typical Products	Specific Gravity² (60 °F)	Product Category	Test D To obtain coverage for a product category, test with one product in the product category. The Certificate of Conformance will cover all products in the category. <ul style="list-style-type: none"> • Test D does not apply to product categories of pure alcohols, pure glycol, pure water, solvents chlorinated, solvents general, fuels, lubricants, industrial and food grade liquid oils. • Test D does not apply to product categories of liquefied gases, compressed liquids or heated products. 			Test C Product Category: Clear Liquid Fertilizers (Fert) continued		Test E Product Category: Solvents General (Solv Gen) continued	

Mass Meter Product Category and Test Requirements			Magnetic Flow Meter Product Category and Test Requirements			Positive Displacement Flow Meter Product Category and Test Requirements		Turbine Flow Meter Product Category and Test Requirements	
			Typical Products	Conductivity (micro-siemens/centimeter)	Product Category	Typical Products	Reference Viscosity ¹ (60 °F) centipoise (cP)	Typical Products	Reference Kinematic Viscosity ¹ (60 °F) centistokes (cSt)
Kerosene	0.75	FL&O							
Light Oil	0.86	FL&O	Water Mixes of Alcohols and Glycols		Alc Gly	N-P-K Solution		Ethylacetate	1.42
Lubricating Oils	0.80 – 0.90	FL&O	Banvel		CC-A	Urea	1	Hexane	0.52
Olive Oil	0.92	FL&O	Herbicides		CC-A	Test C Product Category: Fuels, Lubricants, Industrial and Food Grade Liquid Oils (FL&O)		MEK	0.56
Peanut Oil	0.9 – 1.0	FL&O	Paraquat		CC-A	Typical Products	Reference Viscosity¹ (60 °F) centipoise (cP)	Toluene	0.71
SAE Grades	0.9	FL&O	Prowl		CC-A	6 Oil (#5, #6)	66 – 13,000	Xylene	0.97
Soy Oil	0.93	FL&O	Round-up		CC-A	Asphalt	100 – 5000	Test A The following products must be individually tested and noted on the Certificate of Conformance.	
Spindle Oil		FL&O	Touchdown		CC-A	Avgas	1.5 – 6	Typical Products	Product Category
Sunflower Oil	0.93	FL&O	Treflan		CC-A	Biodiesel above B20	10.12	Banvel	CC-A
Vegetable Oil	0.92	FL&O	Adjuvants		CC-B	Bunker Oil	11,200	Herbicides	CC-A
Liquid Molasses	1.25	Liq Feed	Fumigants		CC-B	Cooking Oils	9.93	Paraquat	CC-A
Molasses Plus Phos Acid and/or Urea (TreaChle)	1.1 – 1.3	Liq Feed	Fungicides		CC-B	Corn Oil	4	Prowl	CC-A
Carbon Tetra-Chloride	1.6	Solv Cl	Insecticides		CC-B	Crude Oil	3-1783	Round-up	CC-A
Methylene-Chloride	1.34	Solv Cl	Fungicides		CC-C	Diesel Fuel ³	10	Touchdown	CC-A
Perchloro-Ethylene	1.6	Solv Cl	Micronutrients		CC-D	Fuel Oil (#1, #2, #3, #4)	8 to 88	Treflan	CC-A
Trichloro-Ethylene	1.47	Solv Cl	Hydrochloric Acid	395000	Chem	Gasoline ⁴	0.28	Adjuvants	CC-B
Acetates	0.93	Solv Gen	Phosphoric Acid	56600	Chem	Jet A	1.5 – 6	Fumigants	CC-B

Mass Meter Product Category and Test Requirements			Magnetic Flow Meter Product Category and Test Requirements			Positive Displacement Flow Meter Product Category and Test Requirements		Turbine Flow Meter Product Category and Test Requirements	
Typical Products	Specific Gravity ² (60 °F)	Product Category	Typical Products	Conductivity (micro-siemens/ centimeter)	Product Categor y	<u>Test C</u> Product Category: Fuels, Lubricants, Industrial and Food Grade Liquid Oils (FL&O) continued		Typical Products	Product Category
						Typical Products	Reference Viscosity ¹ (60 °F) centipoise (cP)		
Acetone	0.8	Solv Gen	Sulfuric Acid	209000	Chem			Fungicides	CC-C
Ethylacetate	0.96	Solv Gen	9-18-0		Fert	Jet A-1	1.36	Insecticides	CC-B
Hexane	0.66	Solv Gen	10-34-0		Fert	Jet B	1.5 – 6	Fungicides	CC-C
MEK	0.81	Solv Gen	20 % Aqua- Ammonia		Fert	JP4	1.02	Micronutrients	CC-D
Toluene	0.87	Solv Gen	28 %, 30 % or 32 %		Fert	JP5	1.94	Hydrochloric Acid	Chem
Xylene	0.89	Solv Gen	Ammonia Nitrate		Fert	JP7 and JP8	1.82	Phosphoric Acid	Chem
Beverages	1.0	Water	Clear Liquid Fertilizer		Fert	Kerosene	1.94	Sulfuric Acid	Chem
Deionized	1.0	Water	Nitrogen Solution		Fert	Light Oil	13.47	NH ₃	Comp Liq
Demineralized	1.0	Water	N-P-K Solutions		Fert	Lubricating Oils	20 – 1000	20 % Aqua- Ammonia	Fert
Juices	1.0	Water	Urea	5000	Fert	Olive Oil	116.8	28 %, 30 % or 32 %	Fert
Milk	1.0	Water	Liquid Molasses	300	Liq Feed	Peanut Oil	11 – 110	9-18-0	Fert
Nonpotable	1.0	Water	Molasses Plus Phos Acid and/or Urea (TreaChle)		Liq Feed	SAE Grades	192 – 3626	10-34-0	Fert
Potable	1.0	Water	3-10-30		Sus Fert	Spindle Oil		Ammonia Nitrate	Fert
Tap Water	1.0	Water	4-4-27		Sus Fert	Soy Oil	90.6	Clear Liquid Fertilizer	Fert

Mass Meter Product Category and Test Requirements			Magnetic Flow Meter Product Category and Test Requirements			Positive Displacement Flow Meter Product Category and Test Requirements		Turbine Flow Meter Product Category and Test Requirements	
Test D To obtain coverage for each of the following product categories, test with one product in each product category. The Certificate of Conformance will cover the products in the product category in which a product was tested.			Beverages		Water	Sunflower Oil	90.1	Nitrogen Solution	Fert
Typical Products	Specific Gravity ² (60 °F)	Product Category	Juices		Water	Vegetable Oil	133	N-P-K Solutions	Fert
Compressed Natural Gas (CNG)	0.6 – 0.8 (1=Air)	Comp gas	Nonpotable	72 ⁵	Water			Urea	Fert
Anhydrous Ammonia	0.61	Comp liq	Potable	72 ⁵	Water			Bicep	Flow
Butane	0.595	Comp liq	Tap Water	72 ⁵	Water			Broadstrike	Flow
Typical Products	Specific Gravity ² (60 °F)	Product Category				Test C Product Category: Flowables (Flow)		Typical Products	Product Category
Ethane		Comp liq				Typical Products	Reference Viscosity ¹ (60 °F) centipoise (cP)	Doubleplay	Flow
Freon 11	1.49	Comp liq				Bicep	20 – 900	Dual	Flow
Freon 12	1.33	Comp liq				Broadstrike	20 – 900	Guardzman	Flow
Freon 22	1.37	Comp liq				Doubleplay	20 – 900	Harness	Flow
Propane	0.504	Comp liq				Dual	20 – 900	Marksman	Flow
Liquefied Natural Gas		Cryo LNG				Guardzman	20 – 900	Topnotch	Flow
Liquefied Oxygen	0.66	Cryo LNG				Harness	20 – 900	Asphalt	Heated
Nitrogen	0.31	Cryo LNG				Marksman	20 – 900	Bunker C	Heated
Asphalt		Heated				Topnotch	20 – 900	Liquid Molasses	Liq Feed
Bunker C	1.1	Heated				Test C Product Category: Heated (Heated)		Molasses plus Phos Acid and/or Urea (TreaChle)	Liq Feed

⁵ This data point is suspected to be lower than that of normal tap water supplied for residential consumption.

Mass Meter Product Category and Test Requirements			Magnetic Flow Meter Product Category and Test Requirements		Positive Displacement Flow Meter Product Category and Test Requirements		Turbine Flow Meter Product Category and Test Requirements	
Test A The following products must be individually tested and noted on the Certificate of Conformance.					Typical Products		Reference Viscosity¹ (60 °F) centipoise (cP)	
Typical Products	Specific Gravity² (60 °F)	Product Category			Asphalt		100 – 5000	
Compressed Hydrogen Gas (H or H2)	0.07 (1=Air)	Comp H2			Bunker C		11,200	
Liquid Carbon Dioxide	1.12 (-40 °F)	Liq CO2						
					Test C Product Category: Liquid Feed (Liq Feed)		Trichloro-Ethylene	
					Typical Products		Reference Viscosity¹ (60 °F) centipoise (cP)	
					Liquid Molasses		8640	
					Molasses Plus Phos Acid and/or Urea (TreaChle)		2882	
							3-10-30	
							4-4-27	
							Compressed Hydrogen Gas (H or H2)	
							Comp H2	
							Liq CO2	

		Test C Product Category: Solvents Chlorinated (Solv Cl)		Test D To obtain coverage for a product category, test with one product in the product category. The Certificate of Conformance will cover all products in the category.	
Typical Products	Reference Viscosity¹ (60 °F) centipoise (cP)	Typical Products	Product Category		
Carbon Tetra-Chloride	0.99	Liquefied Natural Gas	Cryo LNG		
		Test C Product Category: Solvents Chlorinated (Solv Cl) continued		Liquefied Oxygen	
Typical Products	Reference Viscosity¹ (60 °F) centipoise (cP)	Nitrogen	Cryo LNG		
Methylene-Chloride	0.46	Beverages	Water		
Perchloro-Ethylene	1	Deionized	Water		
Trichloro-Ethylene	0.6	Demineralized	Water		

Mass Meter Product Category and Test Requirements	Magnetic Flow Meter Product Category and Test Requirements	Positive Displacement Flow Meter Product Category and Test Requirements	Turbine Flow Meter Product Category and Test Requirements																																
		<p>Test C</p> <p style="text-align: center;">Product Category: Solvents General (Solv Gen)</p> <table border="1" data-bbox="1035 321 1493 594"> <thead> <tr> <th>Typical Products</th> <th>Reference Viscosity¹ (60 °F) centipoise (cP)</th> </tr> </thead> <tbody> <tr><td>Acetates</td><td>0.44</td></tr> <tr><td>Acetone</td><td>0.34</td></tr> <tr><td>Ethylacetate</td><td>1.36</td></tr> <tr><td>Hexane</td><td>0.34</td></tr> <tr><td>MEK</td><td>0.45</td></tr> <tr><td>Toluene</td><td>0.62</td></tr> <tr><td>Xylene</td><td>0.86</td></tr> </tbody> </table> <p>Test C</p> <p style="text-align: center;">Product Category: Suspension Fertilizers (Sus Fert)</p> <table border="1" data-bbox="1035 670 1493 789"> <thead> <tr> <th>Typical Products</th> <th>Reference Viscosity¹ (60 °F) centipoise (cP)</th> </tr> </thead> <tbody> <tr><td>3-10-30</td><td>100 – 1000</td></tr> <tr><td>4-4-27</td><td>20 – 215</td></tr> </tbody> </table>	Typical Products	Reference Viscosity ¹ (60 °F) centipoise (cP)	Acetates	0.44	Acetone	0.34	Ethylacetate	1.36	Hexane	0.34	MEK	0.45	Toluene	0.62	Xylene	0.86	Typical Products	Reference Viscosity ¹ (60 °F) centipoise (cP)	3-10-30	100 – 1000	4-4-27	20 – 215	<table border="1" data-bbox="1493 245 1923 467"> <tbody> <tr><td>Juices</td><td>Water</td></tr> <tr><td>Milk</td><td>Water</td></tr> <tr><td>Nonpotable</td><td>Water</td></tr> <tr><td>Potable</td><td>Water</td></tr> <tr><td>Tap Water</td><td>Water</td></tr> </tbody> </table>	Juices	Water	Milk	Water	Nonpotable	Water	Potable	Water	Tap Water	Water
Typical Products	Reference Viscosity ¹ (60 °F) centipoise (cP)																																		
Acetates	0.44																																		
Acetone	0.34																																		
Ethylacetate	1.36																																		
Hexane	0.34																																		
MEK	0.45																																		
Toluene	0.62																																		
Xylene	0.86																																		
Typical Products	Reference Viscosity ¹ (60 °F) centipoise (cP)																																		
3-10-30	100 – 1000																																		
4-4-27	20 – 215																																		
Juices	Water																																		
Milk	Water																																		
Nonpotable	Water																																		
Potable	Water																																		
Tap Water	Water																																		
		<p>Test D</p> <p>To obtain coverage for a product category, test with one product in the product category. The Certificate of Conformance will cover all products in the category.</p> <p style="text-align: center;">Product Category: Water (Water)</p> <table border="1" data-bbox="1035 963 1493 1235"> <thead> <tr> <th>Typical Products</th> <th>Reference Viscosity¹ (60 °F) centipoise (cP)</th> </tr> </thead> <tbody> <tr><td>Beverages</td><td>1.0</td></tr> <tr><td>Deionized</td><td>1.0</td></tr> <tr><td>Demineralized</td><td>1.0</td></tr> <tr><td>Juices</td><td>1.0</td></tr> <tr><td>Milk</td><td>1.0</td></tr> <tr><td>Nonpotable</td><td>1.0</td></tr> <tr><td>Potable</td><td>1.0</td></tr> </tbody> </table> <p>Test D</p> <p style="text-align: center;">Product Category: Water (Water) continued</p> <table border="1" data-bbox="1035 1312 1493 1408"> <thead> <tr> <th>Typical Products</th> <th>Reference Viscosity¹ (60 °F) centipoise (cP)</th> </tr> </thead> <tbody> <tr><td>Tap Water</td><td>1.0</td></tr> </tbody> </table>	Typical Products	Reference Viscosity ¹ (60 °F) centipoise (cP)	Beverages	1.0	Deionized	1.0	Demineralized	1.0	Juices	1.0	Milk	1.0	Nonpotable	1.0	Potable	1.0	Typical Products	Reference Viscosity ¹ (60 °F) centipoise (cP)	Tap Water	1.0													
Typical Products	Reference Viscosity ¹ (60 °F) centipoise (cP)																																		
Beverages	1.0																																		
Deionized	1.0																																		
Demineralized	1.0																																		
Juices	1.0																																		
Milk	1.0																																		
Nonpotable	1.0																																		
Potable	1.0																																		
Typical Products	Reference Viscosity ¹ (60 °F) centipoise (cP)																																		
Tap Water	1.0																																		

Mass Meter Product Category and Test Requirements	Magnetic Flow Meter Product Category and Test Requirements	Positive Displacement Flow Meter Product Category and Test Requirements	Turbine Flow Meter Product Category and Test Requirements												
		<p>Test A The following products must be individually tested and noted on the Certificate of Conformance.</p> <p>Product Category: Cryogenic Liquids and Liquefied Natural Gas (Cryo LNG)</p> <table border="1" data-bbox="1035 422 1491 584"> <thead> <tr> <th data-bbox="1035 422 1245 470">Typical Products</th> <th data-bbox="1245 422 1491 470">Reference Viscosity¹ (60 °F) centipoise (cP)</th> </tr> </thead> <tbody> <tr> <td data-bbox="1035 470 1245 519">Liquefied Natural Gas</td> <td data-bbox="1245 470 1491 519"></td> </tr> <tr> <td data-bbox="1035 519 1245 552">Liquefied Oxygen</td> <td data-bbox="1245 519 1491 552">0.038</td> </tr> <tr> <td data-bbox="1035 552 1245 584">Nitrogen</td> <td data-bbox="1245 552 1491 584">1.07</td> </tr> </tbody> </table> <p>Test A The following products must be individually tested and noted on the Certificate of Conformance.</p> <p>Product Category: Compressed Hydrogen Gas (Comp H2)</p> <table border="1" data-bbox="1035 730 1491 876"> <thead> <tr> <th data-bbox="1035 730 1245 779">Typical Products</th> <th data-bbox="1245 730 1491 779">Reference Viscosity¹ (60 °F) centipoise (cP)</th> </tr> </thead> <tbody> <tr> <td data-bbox="1035 779 1245 876">Compressed Hydrogen Gas (H or H2)</td> <td data-bbox="1245 779 1491 876">0.0097</td> </tr> </tbody> </table>	Typical Products	Reference Viscosity ¹ (60 °F) centipoise (cP)	Liquefied Natural Gas		Liquefied Oxygen	0.038	Nitrogen	1.07	Typical Products	Reference Viscosity ¹ (60 °F) centipoise (cP)	Compressed Hydrogen Gas (H or H2)	0.0097	
Typical Products	Reference Viscosity ¹ (60 °F) centipoise (cP)														
Liquefied Natural Gas															
Liquefied Oxygen	0.038														
Nitrogen	1.07														
Typical Products	Reference Viscosity ¹ (60 °F) centipoise (cP)														
Compressed Hydrogen Gas (H or H2)	0.0097														
		<p>Test A The following products must be individually tested and noted on the Certificate of Conformance.</p> <p>Product Category: Liquid Carbon Dioxide (Liq CO2)</p> <table border="1" data-bbox="1035 1039 1491 1136"> <thead> <tr> <th data-bbox="1035 1039 1245 1088">Typical Products</th> <th data-bbox="1245 1039 1491 1088">Reference Viscosity¹ (60 °F) centipoise (cP)</th> </tr> </thead> <tbody> <tr> <td data-bbox="1035 1088 1245 1136">Liquid Carbon Dioxide</td> <td data-bbox="1245 1088 1491 1136">0.194</td> </tr> </tbody> </table>	Typical Products	Reference Viscosity ¹ (60 °F) centipoise (cP)	Liquid Carbon Dioxide	0.194									
Typical Products	Reference Viscosity ¹ (60 °F) centipoise (cP)														
Liquid Carbon Dioxide	0.194														

Product Category Table – Category Abbreviations

Abbreviation	Product Category	Abbreviation	Product Category
Alc Gly	Alcohols, Glycols and Water Mixes Thereof	Fert	Fertilizers
CC-A	Crop Chemicals (Type A)	FL&O	Fuels, Lubricants, Industrial and Food Grade Liquid Oils
CC-B	Crop Chemicals (Type B)	Flow	Flowables
CC-C	Crop Chemicals (Type C)	Heated	Heated Products (Above 50 °C)
CC-D	Crop Chemicals (Type D)	Liq Feed	Liquid Feeds
Chem	Chemicals	Liq CO2	Liquid Carbon Dioxide
Comp gas	Compressed Gases	Solv Chl	Solvents Chlorinated
Comp H2	Compressed Hydrogen Gas	Solv Gen	Solvents General
Comp liq	Compressed Liquids (Fuels and Refrigerants, NH ₃)	Sus Fert	Suspension Fertilizers
Cryo LNG	Cryogenic Liquids and Liquefied Natural Gas	Water	Water

Note: The Typical Products listed in this table are not limiting or all-inclusive; there may be other products and product trade names, which fall into a product family. Water and a product such as stoddard solvent or mineral spirits may be used as test products in the fuels, lubricants, industrial, and food-grade liquid oils product family.

THIS PAGE INTENTIONALLY LEFT BLANK

Appendix D/Sub-Appendix E

National Type Evaluation Program Permanence of Markings, LMD Checklist

(Agenda Item 4b)

LMD Checklists and Test Procedures for Retail Motor-Fuel Dispensers – Card-Activated RMFDs:

- Delete the following text associated with Sections 7.18 through 7.21:

~~Credit Card or Debit Card Activated Retail Motor Fuel Dispenser~~

~~On card activated retail motor fuel dispensers, the customer authorizes the dispenser by inserting the card or swiping the card through a slot. On credit card transactions, the customer is typically billed through the same methods as have been used for credit transactions handled through a station attendant. On debit card transactions, payment is made directly from the purchaser's account by electronic funds transfer.~~

~~7.18 A receipt must be available to the customer at the completion of the transaction. The issuance of the receipt may be initiated at the option of the customer.~~ Yes No N/A

~~7.19 The customer receipt must contain the following information:~~

~~7.19.1 The identity (codes may be used) of the product purchased, the quantity purchased, the unit price, and the total price.~~ Yes No N/A

~~7.19.2 Where a post delivery discount(s) is applied, the sales receipt must provide:~~

~~7.19.2.1 the total quantity, unit price, and total computed price that were displayed on the dispenser at the end of the delivery prior to any post-delivery discount(s);~~ Yes No N/A

~~7.19.2.2 an itemization of the post delivery discounts to the unit price; and~~ Yes No N/A

~~7.19.2.3 the final total price of each fuel sale after all post-delivery discounts are applied. See LMD Code S.1.6.8.~~ Yes No N/A

~~7.20 Cash Value Card A cash value card that is initially encoded with the purchase price, authorizing a customer to purchase products up to the current cash value of the card. The value of the card is decreased in amounts equal to individual transactions.~~ Yes No N/A

~~Means shall be provided to the customer to determine the initial cash value of the card and the remaining cash value prior to and after each transaction.~~

~~7.21 Invoice Billing Invoice billing is a process in which customers are billed for one or more transactions at the end of a billing period.~~

~~7.21.1 For computing systems, the date, quantity, unit price, and total price shall be recorded and shall agree with the indications on the dispenser.~~ Yes No N/A

~~7.21.2 When non computing analog dispensers are used and the billing is on the basis of individual quantities for each~~ Yes No N/A

~~transaction (non-cumulative), the value of the smallest unit of displayed quantity for each transaction shall be not greater than 0.1 gallon providing the “pulser” and the recorded quantity used for billing are each equal to or less than 0.01 gallon.~~

~~7.21.3 All displayed transaction information must be shown for at least 30 seconds after completing a delivery or starting the next transaction. The delivery is considered complete after the “handle” is off or after the nozzle has been returned to its designed hanging position.~~ Yes No N/A

- Delete Section 15. Card Activated Retail Motor-Fuel Dispensers:

Note: This text is redundant to that in current checklist Sections 40.1 through 40.4.

~~15. Card Activated Retail Motor Fuel Dispensers~~

~~Code Reference: G S.2. Facilitation of Fraud~~

~~Accidental or intentional fraud causes great concern when customers use card-activated systems in service stations, bank card-activated systems directly access bank accounts. The following criteria and test procedures apply to card-activated retail motor fuel dispensers.~~

~~A card-activated system shall authorize the dispensing of product for not more than three minutes for the time between authorization and “handle on” at the dispenser. It shall properly record transactions on the appropriate card account.~~

~~When a card-activated system is subjected to power loss of greater than 10 seconds, the dispenser shall de-authorize. Because systems may be installed with separate power lines to the console, card reader, and dispenser, tests should be run with power failures to different parts of the system to evaluate the potential for accidental or intentional errors. The appropriate device response depends when the power loss occurs during the delivery sequence.~~

~~15.1 The dispenser must de-authorize in not more than three minutes if the pump “handle” is not turned on.~~ Yes No N/A

~~15.2 If the time limit to deactivate a dispenser is programmable, it shall not accept an entry greater than three minutes.~~ Yes No N/A

~~15.3 When a power loss greater than 10 seconds occurs after the pump “handle” is on, the dispenser must de-authorize.~~ Yes No N/A

~~15.4 When there is a loss of power, but the pump “handle” is not on, the dispenser must de-authorize in not more than three minutes.~~ Yes No N/A

- Delete Section 16. Test Methods for Card-Activated Retail Motor-Fuel Dispensers:

Note: This text is redundant to that in current checklist Section 41.

~~16. Test Methods for Card-Activated Retail Motor Fuel Dispensers~~

~~16.1 Authorize the dispenser and, with the pump “handle” on, interrupt power to any part (or all) of the system. The pump should deauthorize immediately. Specifically:~~

~~16.1.1. Authorize with a card and turn the “handle” on.~~ Yes No N/A

~~Power down briefly, then restore power. Try to dispense product; the dispenser must not dispense because the power failure should have de-authorized the dispenser.~~

16.2 ~~Authorize the dispenser using a card (leaving handle off); wait more than three minutes, and try to start the dispenser. It should not start because the authorization should have timed out. Specifically:~~

16.2.1. ~~Authorize with a card, but do not turn the “handle” on. Power down for more than three minutes, and then restore power. Try to dispense product; the dispenser should have “timed out” and not dispense.~~ Yes No N/A

16.2.2. ~~Authorize and dispense with card #1. Allow the system to time out and de-authorize (if it does). Do not turn off the “handle.” Authorize and dispense with card #2. The transactions shall be properly recorded for each card.~~ Yes No N/A

Note: A mechanical register may accumulate the two deliveries, but the printed record must not have accumulated values.

16.2.3. ~~Authorize with card #1. Turn the “handle” on, then off. Authorize with card #2. Dispense product and complete the delivery. Check the printed receipt to verify that the delivery has been properly charged to card #2.~~ Yes No N/A

16.2.4. ~~Turn the dispenser “handle” on, and use a card to authorize the dispenser. Turn the “handle” off. After a period of 15 seconds, turn the “handle” on. Try to deliver product; the dispenser must not dispense.~~ Yes No N/A

16.2.5. ~~Authorize with card #1 (do not turn the “handle” on) and interrupt power for at least 10 seconds. This should de-authorize the dispenser. Resupply power; turn the “handle” on; try to dispense. The dispenser shall not deliver product.~~ Yes No N/A

Note: The term “handle” generically refers to the handle, flapper, start button, on/off switch, or other mechanism used to activate or deactivate the dispenser.

16.2.6. ~~Authorize with card #1; turn the “handle” on, and then interrupt power. This should de-authorize the dispenser. Resupply power and authorize the dispenser with card #2. Then, complete a delivery. Verify that the transaction is charged to card #2.~~ Yes No N/A

Note: This test is not required if the device under test complies with paragraph 16.1.

16.2.7. ~~Authorize a dispenser with card #1, but do not turn the dispenser “handle” on. Try to authorize the same dispenser with card #2; it should not be accepted until after the 3 minute time out.~~ Yes No N/A

16.3. ~~Attempt to override or confuse the card system by varying the length of time the card is in the slot, (e.g., vary the “swipe” times) and pushing all other keys on the keypad during each step of the authorization process.~~ Yes No N/A

NTEP LMD Additional Checklists and Test Procedures for Card-Activated Retail Motor-Fuel Dispensers:

- Move the preamble to Sections 7.18 through 7.21. (shown above) to the beginning of the “NTEP LMD Additional Checklists and Test Procedures for Card-Activated Retail Motor-Fuel Dispensers.”
- Create a new “Code Reference G-S.5.1. Indicating and Recording Elements” under “NTEP LMD Additional Checklists and Test Procedures for Card-Activated Retail Motor-Fuel Dispensers,” and move the text currently in Sections 7.20 and 7.21 (shown above) to this new code reference.
- Create a new Code Reference heading for LMD Code paragraphs S.1.6.7. Recorded Representation and S.1.6.8. Recorded Representations for Transactions Where a Post-Delivery Discount(s) is Provided and insert text from 7.18 through 7.19., modified to reflect current NIST Handbook 44 language in this new reference.

Resulting changes in the “Additional Checklists and Test Procedures for Card-Activated Retail Motor-Fuel Dispensers” will appear as follows:

National Type Evaluation Program Liquid Measuring Devices – Additional Checklists and Test Procedures for Card-Activated Retail Motor Fuel Dispensers

40. Card-Activated Retail Motor Fuel Dispensers

On card-activated retail motor fuel dispensers, the customer authorizes the dispenser by inserting the card or swiping the card through a slot. On credit card transactions, the customer is typically billed through the same methods as have been used for credit transactions handled through a station attendant. On debit card transactions, payment is made directly from the purchaser's account by electronic funds transfer.

Code Reference: G-S.5.1. Indicating and Recording Elements

40.1. Cash Value Card - A cash value card that is initially encoded with the purchase price, authorizing a customer to purchase products up to the current cash value of the card. The value of the card is decreased in amounts equal to individual transactions. Yes No N/A

Means shall be provided to the customer to determine the initial cash value of the card and the remaining cash value prior to and after each transaction.

40.2 Invoice Billing - Invoice billing is a process in which customers are billed for one or more transactions at the end of a billing period.

40.2.1 For computing systems, the date, quantity, unit price, and total price shall be recorded and shall agree with the indications on the dispenser. Yes No N/A

40.2.2 When non-computing analog dispensers are used and the billing is on the basis of individual quantities for each transaction (non-cumulative), the value of the smallest unit of displayed quantity for each transaction shall be not greater than 0.1 gallon providing the “pulser” and the recorded Yes No N/A

quantity used for billing are each equal to or less than 0.01 gallon.

- 40.2.3 **All displayed transaction information must be shown for at least 30 seconds after completing a delivery or starting the next transaction. The delivery is considered complete after the “handle” is off or after the nozzle has been returned to its designed hanging position.** Yes No N/A

Code Reference: G-S.2. Facilitation of Fraud

There is great concern regarding the potential for accidental or intentional fraud when card-activated systems are used in service stations, especially because bank-card-activated systems give direct access to bank accounts. ~~The following criteria and test procedures apply to card-activated retail motor fuel dispensers.~~

A card-activated system shall authorize the dispensing of product for not more than three minutes of the time between authorization and “handle on” at the dispenser. It shall properly record transactions on the appropriate card account.

When a card-activated system is subjected to power loss of greater than 10 seconds, the dispenser shall deauthorize. Because systems may be installed with separate power lines to the console, card reader, and dispenser, to different parts of the system should be tested with power failures to evaluate the potential for accidental or intentional errors. The appropriate device response depends upon when the power loss occurs during the delivery sequence.

- ~~40.140.3~~ The dispenser must de-authorize in not more than three minutes if the pump “handle” is not turned on. Yes No N/A
- ~~40.240.4~~ **If the time limit to deactivate a dispenser is programmable, it shall not accept an entry greater than three minutes.** Yes No N/A
- ~~40.340.5~~ **When a power loss greater than 10 seconds occurs after the pump “handle” is on, the dispenser must de-authorize.** Yes No N/A
- ~~40.440.6~~ **When there is a loss of power, but the pump “handle” is not on, the dispenser must de-authorize in not more than three minutes.** Yes No N/A

Code References: S.1.6.7. Recorded Representations; and S.1.6.8. Recorded Representations for Transaction Where a Post-Delivery Discount(s) is Provided.

Except for fleet sales and other price contract sales, for transactions conducted with point-of-sale systems or devices activated by credit cards, debit cards, or cash, a printed receipt containing information about the transaction shall be available to the customer as outlined in the following items. **A printed receipt must always be available to the customer upon request and printing of the receipt may be initiated at the option of the customer. In addition, some systems may be equipped with the capability to issue an electronic receipt; for those systems, the customer may be given the option to receive the receipt electronically (e.g., via cell phone, computer, etc.).**

- 40.7 The system must provide a receipt to be made available to the customer at the completion of the transaction through either:**
- 40.7.1. **a built-in recording element OR** Yes No N/A
- 40.7.2. **a separate recording element that is part of the system** Yes No N/A

Indicate the option(s) available for providing a receipt:

- Hard Copy or Electronic**
- Hard Copy and Electronic**

40.8 Except for transactions where a post-delivery discount is provided, the customer receipt must contain the following information:

- 40.8.1 The total volume of the delivery;** Yes No N/A
- 40.8.2. The unit price;** Yes No N/A
- 40.8.3. The total computed price; and** Yes No N/A
- 40.8.4. The product identity by name, symbol, abbreviation, or code number.** Yes No N/A

40.9 Where a post-delivery discount(s) is applied, the sales receipt must provide:

- 40.9.1. The product identity by name, symbol, abbreviation, or code number;**
- 40.9.1 the total quantity, unit price, and total computed price that were displayed on the dispenser at the end of the delivery prior to any post-delivery discount(s);** Yes No N/A
- 40.9.2. an itemization of the post-delivery discounts to the unit price; and** Yes No N/A
- 40.9.3. the final total price of each fuel sale after all post-delivery discounts are applied.** Yes No N/A

41. Test Methods

- 41.1. Authorize the dispenser and, with the pump “handle” on, interrupt power to any part (or all) of the system. The pump should de-authorize immediately. Specifically:
 - 41.1.1. Authorize with a card and turn the “handle” on. Power down briefly then restore power. Try to dispense product, the dispenser must not dispense since the power failure should have de-authorized the dispenser. Yes No N/A
 - 41.2. Authorize the dispenser using a card (leaving handle off), wait more than three minutes, and try to start the dispenser. It should not start because the authorization should have timed out. Specifically:
 - 41.2.1. Authorize with a card, but do not turn the “handle” on. Power down for more than three minutes, and then restore power. Try to dispense product, the dispenser should have “timed-out” and not dispense. Yes No N/A
 - 41.2.2. Authorize and dispense with card #1. Allow the system to time out and de-authorize (if it does.) Do not turn off the “handle.” Authorize and dispense with card #2. The transactions shall be properly recorded for each card. Yes No N/A
- Note: A mechanical register may accumulate the two deliveries, but the printed record must not have accumulated values.*
- 41.2.3. Authorize with card #1. Turn the “handle” on, then off. Authorize with card #2. Dispense product and complete the delivery. Check the printed receipt to verify that the delivery has been properly charged to card #2. Yes No N/A

- 41.2.4. Turn the dispenser “handle” on and use a card to authorize the dispenser. Turn the “handle” off, then on. Try to deliver product: the dispenser must not dispense. Yes No N/A

For Multi-hose Dispensers:

- 41.2.5. Turn the dispenser “handle” on and use a card to authorize the dispenser. Turn the “handle” off. After a period of 15 seconds, turn the “handle” on. Try to deliver product; the dispenser must not dispense. Yes No N/A
- 41.2.6. Authorize with card #1 (do not turn the “handle” on) and interrupt power for at least 10 seconds. This should de-authorize the dispenser. Resupply power, turn “handle” on, and try to dispense. The dispenser shall not deliver product. Yes No N/A
- 41.2.7. Authorize with card #1, turn the “handle” on, and then interrupt power. This should de-authorize the dispenser. Resupply power and authorize the dispenser with card #2, then complete a delivery. Verify that the transaction is charged to card #2. Yes No N/A
- 41.2.8. Authorize a dispenser with card #1, but do not turn the dispenser “handle” on. Try to authorize the same dispenser with card #2, it should not be accepted until after the three minute time-out. Yes No N/A
- 41.3. Attempt to override or confuse the card system by: varying the length of time the card is in the slot (e.g., vary the “swipe” times, and pushing all other keys on the keypad during each step of the authorization process). Yes No N/A

THIS PAGE INTENTIONALLY LEFT BLANK

Appendix D/Sub-Appendix F

National Type Evaluation Program Proposed Additions to the Additional Checklists and Test Procedures for Cash-Activated RMFDs

(Agenda Item 4b)

Code References: G-S.5.1. and S.1.6.7

Except for fleet and other price contract sales, a printed receipt showing the quantity, unit price, total price, and product identity for each fuel delivery in a transaction is required for cash-activated RMFDs. A printed receipt must always be available to the customer upon request and printing of the receipt may be initiated at the option of the customer. In addition, some systems may be equipped with the capability to issue an electronic receipt for those systems, the customer may be given the option to receive the receipt electronically (e.g., via cell phone, computer, etc.).

Various forms (or representations) of sales receipt formats are acceptable provided they are clear and understandable. Guidelines are provided to assist manufacturers and weights and measures officials in determining the acceptability of formats. Symbols other than those given below may be acceptable, but they will be reviewed on a case-by-case basis. More descriptive symbols and terms are acceptable.

17.10 The system must provide a receipt to be made available to the customer at the completion of the transaction through either: Yes No N/A

a built-in recording element OR

a separate recording element that is part of the system

Indicate the option(s) available for providing a receipt:

Hard Copy or Electronic

Hard Copy and Electronic

17.11 Except for transactions where a post-delivery discount is provided, the customer receipt must contain the following information:

17.11.1 The total volume of the delivery; Yes No N/A

17.11.2 The unit price; Yes No N/A

17.11.3 The total computed price; and Yes No N/A

17.11.4 The product identity by name, symbol, abbreviation, or code number. Yes No N/A

17.12 Where a post-delivery discount(s) is applied, the sales receipt must provide:

17.12.1 the total quantity, unit price, and total computed price that were displayed on the dispenser at the end of the delivery prior to any post-delivery discount(s); Yes No N/A

17.12.2 an itemization of the post-delivery discounts to the unit price; and Yes No N/A

17.12.3 the final total price of each fuel sale after all post-delivery discounts are applied. Yes No N/A

17.13 The unit of measure shall be clearly defined. Acceptable symbols for units are: Gallon Gal, of G for gallons and Liter, l or L for liters. Upper or lower case is optional except that a lower case "l" must not Yes No N/A

resemble a “1” (numeral one), (e.g. a script “1” is an acceptable symbol for liters.)

The unit of measure may be defined with either the quantity value, (e.g., 10 000 GAL) or with the unit price, (e.g., \$1.119/Gal), not necessarily both.

17.14 Acceptable designations of the unit price are: “@” as a prefix to the unit price value, an upper or lower case “X” or slash between the quantity and unit price, \$/G, PPG (price per gallon), PPL (price per liter), UP (unit price), P/G, price/Vol, PPU (price per unit), DOL/GAL.

17.15 The total fuel price must be clearly distinguished from other information in the fuel transaction. To identify the total fuel sale price, use one of the following methods:

17.15.1 Decimal point in the proper dollar position, (e.g., XX.XX.) If a dollar sign is not used, there must be at least one offset column of the least significant digit in recorded information, other than the sale price.

Yes No N/A

17.15.2 The words gas, diesel, or other product designation may be used with the word “SALE” (e.g., “FUEL SALE” or “GAS SALE”) or the product identification followed by the sale price, (e.g., GAS 20.00.)

Yes No N/A

Appendix D/Sub-Appendix G

National Type Evaluation Program Proposed Changes to the ECR Interfaced with RMFDs Checklist

(Agenda Item 4e)

3. Recorded Representations

Code Reference: G-S.5.1. S.1.6.7, and S.1.6.8.

Except for fleet and other price contract sales, a sales printed receipt showing the quantity, unit price, total price, and product identity for each fuel delivery in a transaction is required for point-of-sale systems. A printed receipt must always be available to the customer upon request **and printing of the receipt may be initiated at the option of the customer.** In addition, some systems may be equipped with the capability to issue an electronic receipt. **For those systems, the** customer may be given the option to receive the receipt electronically (e.g., via cell phone, computer, etc.).

Various forms (or representations) of sales receipt formats are acceptable provided they are clear and understandable. Guidelines are provided to assist manufacturers and weights and measures officials in determining the acceptability of formats. Symbols other than those given below may be acceptable, but they will be reviewed on a case-by-case basis. More descriptive symbols and terms are acceptable.

3.1 The system must provide a receipt to be made available to the customer at the completion of the transaction through either: Yes No N/A

a built-in recording element OR

a separate recording element that is part of the system

Indicate the option(s) available for providing a receipt:

Hard Copy or Electronic

Hard Copy and Electronic

3.2 Except for transactions where a post-delivery discount is provided, the customer receipt must contain the following information:

3.2.1 The total volume of the delivery; Yes No N/A

3.2.2 The unit price; Yes No N/A

3.2.3 The total computed price; and Yes No N/A

3.2.4 The product identity by name, symbol, abbreviation, or code number. Yes No N/A

3.3 Where a post-delivery discount(s) is applied, the sales receipt must provide:

3.3.1 the total quantity, unit price, and total computed price that were displayed on the dispenser at the end of the delivery prior to any post-delivery discount(s); Yes No N/A

3.3.2 an itemization of the post-delivery discounts to the unit price; and Yes No N/A

3.3.3 the final total price of each fuel sale after all post-delivery discounts are applied. Yes No N/A

- 3.14 The unit of measure shall be clearly defined. Acceptable symbols for units are: Gallon Gal, of G for gallons and Liter, l or L for liters. Upper or lower case is optional except that a lower case “l” must not resemble a “1” (numeral one), (e.g. a script “l” is an acceptable symbol for liters.) Yes No N/A
 The unit of measure may be defined with either the quantity value, (e.g., 10 000 GAL) or with the unit price, (e.g., \$1.119/Gal), not necessarily both.
- 3.25 Acceptable designations of the unit price are: “@” as a prefix to the unit price value, an upper or lower case “X” or slash between the quantity and unit price, \$/G, PPG (price per gallon), PPL (price per liter), UP (unit price), P/G, price/Vol, PPU (price per unit), DOL/GAL.
- 3.36 The total fuel price must be clearly distinguished from other information in the fuel transaction. To identify the total fuel sale price, use one of the following methods:
- 3.36.1 Decimal point in the proper dollar position, (e.g., XX.XX.) If a dollar sign is not used, there must be at least one offset column of the least significant digit in recorded information, other than the sale price. Yes No N/A
- 3.36.2 The words gas, diesel, or other product designation may be used with the word “SALE” (e.g., “FUEL SALE” or “GAS SALE”) or the product identification followed by the sale price, (e.g., GAS 20.00.) Yes No N/A
- 3.47 Each fuel delivery in a transaction for a single customer must be recorded separately. Yes No N/A
- ~~3.5 Where a post delivery discount(s) is applied, the sales receipt must provide: the total quantity, unit price, and total computed price that were displayed on the dispenser at the end of the delivery prior to any post delivery discount(s); an itemization of the post delivery discounts to the unit price; and the final total price of each fuel sale after all post delivery discounts are applied. See LMD Code S.1.6.8. :~~ Yes No N/A
- 3.68 The product identity for fuel need only distinguish it from other items. The product name, code number (similar to a price look-up code), or hose or pump number are acceptable designations of product identify. See LMD Code S.1.6.4. Yes No N/A

Example 1		Example 2	
Meat	3.89	Meat	3.89
Soda	2.99	Soda	2.99
Gas 5.080 G @ 1.000	5.08	Gas 4.080 G @ 1.000	4.08
Cig	1.00		

Note: NIST Handbook 44 does not require that product identification, date, and change due be printed on a ticket or a cash register receipt. These requirements apply to recorded representations resulting from a final sale, not to deposit slips for prepay transactions, etc.

Sub-Appendix G – Proposed Changes to the ECRF Interfaced with RMFDs Checklist, Rev 11-12-13 (Agenda Item 4e)

- 3.79 The quantity representation of an item sold by count must be expressed in whole units. An expression of count with a decimal point and trailing zeroes, (e.g., 2.00 items) is acceptable provided that fractions of a whole unit cannot be expressed. Yes No N/A

THIS PAGE INTENTIONALLY LEFT BLANK

Appendix E

National Type Evaluation Technical Committee (NTETC) Software Sector Meeting Summary

March 19-20, 2013
Columbus, Ohio

INTRODUCTION

The charge of the NTETC Software Sector is important in providing appropriate type evaluation criteria for software-based weighing or measuring device based on specifications, tolerances and technical requirements of NIST Handbook 44, *Specifications, Tolerances, and Other Technical Requirements for Weighing and Measuring Devices*, Section 1.10. General Code, Section 2 for weighing devices, Section 3 for liquid and vapor measuring devices, and Section 5 for taximeters, grain analyzers, and multiple dimension measuring devices. The Sector’s recommendations are presented to the National Type Evaluation Program (NTEP) Committee each January for approval and inclusion in NCWM Publication 14, *Technical Policy, Checklists, and Test Procedures*, for national type evaluation.

The Sector is also called upon occasionally for technical expertise in addressing difficult NIST Handbook 44 issues on the agenda of the National Conference on Weights and Measures (NCWM) Specifications and Tolerances (S&T) Committee. Sector membership includes industry, NTEP laboratory representatives, technical advisors, and the NTEP Administrator. Meetings are held annually, or as needed and are open to all NCWM members and other registered parties.

Proposed revisions to the handbook(s) are shown as follows: 1) deleted language is indicated with a **bold face font using strikeouts** (e.g., ~~this report~~), 2) proposed new language is indicated with an **underscored bold faced font** (e.g., new items), and 3) nonretroactive items are identified in *italics*. There are instances where the Sector will use **red** text and/or **highlighted** text to bring emphasis to text that requires additional attention. When used in this report, the term “weight” means “mass.”

Note: It is the policy of the National Institute of Standards and Technology (NIST) to use metric units of measurement in all of its publications; however, recommendations received by NCWM technical committees and regional weights and measures associations have been printed in this publication as submitted. Therefore, the report may contain references in inch-pound units.

Table A
Table of Contents

Title of Content	Page NTEP E
INTRODUCTION	1
WELCOME/INTRODUCTIONS	2
STATUS REPORTS – RELATED NCWM AND INTERNATIONAL ACTIVITY	2
CARRY-OVER ITEMS	3
1. Software Identification/Markings	3
2. Identification of Certified Software	6
3. Software Protection/Security	10
4. Software Maintenance and Reconfiguration.....	14
5. NTEP Application for Software and Software-based Devices	16
6. Training of Field Inspectors.....	17

NEW ITEMS..... 20

7. Next Meeting 20

8. 2013 NCWM Interim Meeting Report..... 21

9. 2013 International Report 21

10. 360-7 D Appendix D – Definitions: Remote Configuration Capability 21

Appendix

A. Appendix – List of Acceptable Menu Text/Icons for Identification of Certificate Number E / A1

Table B
Glossary of Acronyms and Terms

Acronym	Term	Acronym	Term
BIML	International Bureau of Legal Metrology	OIML	International Organization of Legal Metrology
CC	Certificate of Conformance	OWM	Office of Weights and Measures
EPO	Examination Procedure Outline	PDC	Professional Development Committee
GMMs	Grain Moisture Meters	PDC	Professional Development Committee
NCWM	National Conference on Weights and Measures	S&T	Specifications and Tolerances Committee
NTEP	National Type Evaluation Program	SMA	Scale Manufacturers Association
NTETC	National Type Evaluation Technical Committee	WELMEC	European Cooperation in Legal Metrology

Details of All Items
(In order by Reference Key)

WELCOME/INTRODUCTIONS

The Chair would like to welcome new individuals that have joined the NTETC Software Sector since the last meeting. Please welcome:

- Eric Morabito, New York Bureau of Weights & Measures
- Gary Benjamin, NCR Corporation

STATUS REPORTS – RELATED NCWM AND INTERNATIONAL ACTIVITY

Attendees of the 2013 NCWM Interim Meeting will be asked to share any relevant comments or discussion that took place during the open hearings or NCWM Standards and Tolerances (S&T) Committee working sessions.

Mr. Jim Truex was the only Sector attendee at the Interim Meeting. He doesn't recall any comments on the floor. After the hearings, he had a brief discussion with the S&T Committee, to little effect.

Dr. Ambler Thompson, NIST, Office of Weights and Measures (OWM), will provide a synopsis of international activity that relates to the work of the Sector.

The new proposed revision of OIML has increased the risk classifications. The next CIML meeting is set for October.

CARRY-OVER ITEMS

1. Software Identification/Markings

Source:

NTETC Software Sector

Background:

Since its inception the Sector has wrestled with the issue of software identification and marking requirements. *See the 2012 Software Sector Meeting Summary and the 2013 Interim Meeting S&T Agenda Item 360-2 for more background on this item.*

NIST, OWM had been adding items to the S&T Agendas that confused matters since the perception was that this Sector had contributed to this input. Most of the confusion arose in the 1990s, due to some items being approved, and others, such as the definitions for “Built-for-Purpose” and “Not-Built-for -Purpose,” not being approved.

Mr. Truex, NTEP Administrator, discussed the difficulty there has been in coming to a consensus on these issues with a representative of the NTEP Committee. Suggestions from NTEP to come to some resolution has been to write an article for the newsletter (which Mr. Bliss, Mettler-Toledo, LLC, had already done, to no effect), sending a questionnaire to the NTEP community, asking what they would like to see, and sending a representative from this Sector to the S&T Committee.

Mr. Roach (California Division of Measurement Standards) is concerned that some people may want to interpret G-S.1.(c) as requiring a serial number for software. Mr. Lewis (Rice Lake Weighing Systems, Inc.) pointed out that the computer the software was running on could have the serial number, not the software itself. That shouldn't matter, regardless.

Mr. Bliss (Mettler-Toledo, LLC) pointed out that the terminology in G-S.1. “All equipment,” could be interpreted to mean that it doesn't apply to software. It was proposed that G-S.1.(c) be amended to add “and software.” Mr. Bliss suggested submitting a document explaining the reasoning behind the proposed changes, rather than assume the text is self-explanatory. Making a presentation to the various Committees on the subject in addition would be beneficial as well. If a document is written, perhaps the examples given in G-S.1.(d)(3)(a) can be eliminated. “Metrologically significant” isn't explicitly defined, but it's been used since time immemorial.

Attempts to modify G-S.1.1. have been controversial, both in this meeting and in other committees. Unfortunately, there has been little constructive feedback from the other Committees. It would probably be easier to incorporate specific examples given in G-S.1.1(b)3 in *NCWM Publication 14*. After some discussion, the previously proposed language was modified slightly to address some of the concerns received via feedback from other Sectors and interested parties:

NIST Handbook 44 – Proposed Changes:

G-S.1. Identification. – All equipment, except weights and separate parts necessary to the measurement process but not having any metrological effect, shall be clearly and permanently marked for the purposes of identification with the following information:

- (a) the name, initials, or trademark of the manufacturer or distributor;

- (b) a model identifier that positively identifies the pattern or design of the device;
- (1) *The model identifier shall be prefaced by the word “Model,” “Type,” or “Pattern.” These terms may be followed by the word “Number” or an abbreviation of that word. The abbreviation for the word “Number” shall, as a minimum, begin with the letter “N” (e.g., No or No.). The abbreviation for the word “Model” shall be “Mod” or “Mod.” Prefix lettering may be initial capitals, all capitals, or all lowercase.*
[Nonretroactive as of January 1, 2003]
(Added 2000) (Amended 2001)
- (c) a nonrepetitive serial number, except for equipment with no moving or electronic component parts and ~~not built for purpose software based software devices~~ **software**;
[Nonretroactive as of January 1, 1968]
(Amended 2003)
- (1) *The serial number shall be prefaced by words, an abbreviation, or a symbol, that clearly identifies the number as the required serial number.*
[Nonretroactive as of January 1, 1986]
- (2) *Abbreviations for the word “Serial” shall, as a minimum, begin with the letter “S,” and abbreviations for the word “Number” shall, as a minimum, begin with the letter “N” (e.g., S/N, SN, Ser. No., and S. No.).*
[Nonretroactive as of January 1, 2001]
- (d) the current software version or revision identifier—~~for not built for purpose software based electronic devices~~, **which shall be directly linked to the software itself**;
[Nonretroactive as of January 1, 2004]
(Added 2003) (**Amended 20XX**)
- (1) *The version or revision identifier shall be prefaced by words, an abbreviation, or a symbol, that clearly identifies the number as the required version or revision.*
[Nonretroactive as of January 1, 2007]
(Added 2006)
- (2) *Abbreviations for the word “Version” shall, as a minimum, begin with the letter “V” and may be followed by the word “Number.” Abbreviations for the word “Revision” shall, as a minimum, begin with the letter “R” and may be followed by the word “Number.” The abbreviation for the word “Number” shall, as a minimum, begin with the letter “N” (e.g., No or No.).*
[Nonretroactive as of January 1, 2007]
(Added 2006)
- (3) **The version or revision identifier shall be accessible via the display. Instructions for displaying the version or revision identifier shall be described in the CC. As an exception, permanently marking the version or revision identifier shall be acceptable under the following conditions:**
- (a) **The user interface does not have any control capability to activate the indication of the version or revision identifier on the display, or the display does not technically allow the version or revision identifier to be shown (analog indicating device or electromechanical counter,) or**
- (b) **the device does not have an interface to communicate the version or revision identifier.**
- (e) an NTEP CC number or a corresponding CC Addendum Number for devices that have a CC.
- (1) *The CC Number or a corresponding CC Addendum Number shall be prefaced by the terms “NTEP CC,” “CC,” or “Approval.” These terms may be followed by the word “Number” or an*

abbreviation of that word. The abbreviation for the word “Number” shall, as a minimum, begin with the letter “N” (e.g., No or No.)
[Nonretroactive as of January 1, 2003]

The required information shall be so located that it is readily observable without the necessity of the disassembly of a part requiring the use of any means separate from the device.

(Amended 1985, 1991, 1999, 2000, 2001, 2003, ~~and~~, 2006 and 201X)

G-S.1.1. Location of Marking Information for ~~Not-Built-For-Purpose~~ all Software-Based Devices. – *For ~~not-built-for-purpose~~, software-based devices, either:*

- (a) The required information in G-S.1. Identification. (a), (b), ~~(d)~~, and (e) shall be permanently marked or continuously displayed on the device; or*
- (b) The CC Number shall be:*
 - (1) permanently marked on the device;*
 - (2) continuously displayed; or*
 - (3) accessible through an easily recognized menu and, if necessary, a submenu. Examples of menu and submenu identification include, but are not limited to, “Help,” “System Identification,” “G-S.1. Identification,” or “Weights and Measures Identification.”*

Note: *For (b), clear instructions for accessing the information required in G-S.1. (a), (b), and (d) shall be listed on the CC, including information necessary to identify that the software in the device is the same type that was evaluated.*

[Nonretroactive as of January 1, 2004]

(Added 2003) (Amended 2006 and 20XX)

The new language in G-S.1.1. reflects that the sector reached consensus on the following positions:

- The software version/revision should (with very few exceptions – see D-31 5.1.1.) be accessible via the user interface.
- The means by which the software version is accessed must be described in the Certificate of Conformance (CC).

The Sector promoted this item following the meeting via several means to try and address the concerns of other interested parties. A presentation was generated and shared with the S.M.A. at their meeting. The regions had access to this information, as it was posted on the NCWM website. Unfortunately, based on the comments in the 2013 NCWM Publication 15 Item 360-2, some regions were not aware that this information had been provided.

During the 2013 NCWM Interim Meeting, no comments were received relative to this item during the Open Hearings. In considering the item, the Committee questioned whether or not the Software Sector was still actively working the item. It was reported that the Software Sector believed they had developed the item as much as possible, yet the different stakeholders affected by the proposal could not agree on the changes that the Sector had proposed. Based upon that update, the Committee agreed to add to its report a request that the Software Sector work with the Weighing Sector and Measuring Sector to identify which portions of the proposal need to be modified in order that they might be accepted by the entire community. The Committee acknowledges and appreciates the efforts of the Software Sector and looks forward to being able to consider a proposal that addresses both the identification of software and how it may be accessed.

Discussion:

Since the 2012 meeting, the Sector has attempted to promote this item via several means to try and address the concerns of other interested parties. A presentation was generated and shared with the S.M.A. at their 2012 meeting. Most of the regions had access to this information prior to their meetings, as it was posted on the NCWM website. Unfortunately, based on the comments in the 2013 NCWM Publication 15, Item 360-2, some regions were not aware that this information had been made available.

In addition, it was noted that it may be desirable to evaluate options that would lead to fully eliminating GS-1.1. It was noted that this would be a more invasive modification to the existing Handbook and perhaps should be put off until the first step of addressing software in all devices (not just standalone) was accomplished.

Conclusion:

The Sector considers this item sufficiently developed. The one response to our request for review/comment that contained negative feedback was undeniably vague and non-constructive. The issue seems to be more one of communication/understanding than disagreement with the intent or wording. We may want to consider more direct methods, that is, designating a representative to address the regional groups or other Sectors at their meetings. The annual meeting may be an appropriate venue for a presentation.

To move this forward, someone should address the regional groups. There are five to six potential venues for presentations. The last slide from the current presentation should be eliminated, to avoid confusing matters, for the time being. The two regional meetings in the fall (Western and Southern) and the interim meeting are probably more critical than the ones in May. Dr. Thompson was asked to relay that we have a presentation available and would like to push our proposal as a Voting Item in 2014. To be part of the January 2014 Annual S&T committee’s hearings/agenda, this needs to be brought to Mr. Rick Harshman’s attention. Dr. Thompson volunteered to speak with him.

After removing the “and inseparably” terminology from the proposal, the concerns on the possibility of controversy were reduced.

The Sector’s opinion on the interpretation of “directly linked” is that it means that you can’t change the version/revision without changing the software.

It was recommended that a couple examples be added to the current slide presentation, to illustrate the intent of the proposed changes. One example might be supermarket-specific software designed to run upon a cash register. Another example might be, after a software change, noting that the new software version/revision number is no longer the same, and the operator was not prompted to enter a version/revision number.

Note: The text in red is a modification in the proposal made this year – the new text was inserted to address our Agenda Item 2. Upon the suggestion of NIST, OWM, the modifications to NIST Handbook 44 in these items were combined to avoid having to forward another proposal to modify Handbook 44 simultaneously or in the immediate future.

2. Identification of Certified Software

Source:

NTETC Software Sector

Background:

This item originated as an attempt to answer the question “How does the field inspector know that the software running in the device is the same software evaluated and approved by the lab?” In previous meetings it was shown that the international community has addressed this issue (both WELMEC and OIML).

From WELMEC 7.2:

Required Documentation:

The documentation shall list the software identifications and describe how the software identification is created, how it is inextricably linked to the software itself, how it may be accessed for viewing, and how it is structured in order to differentiate between version changes with and without requiring a type approval.

From OIML D-31:

The executable file “**tt100_12.exe**” is protected against modification by a checksum. The value of checksum as determined by algorithm **XYZ** is **1A2B3C**.

Previous discussions have included a listing of some additional examples of possible valid methods (not limiting):

- CRC (cyclical redundancy check)
- Checksum
- Inextricably Linked version no.
- Encryption
- Digital Signature

Is there some method to give the weights and measures inspector information that something has changed?

Yes, the Category III Audit Trail or other means of sealing.

How can the weights and measures inspector identify an NTEP Certified version?

They can't, without adding additional requirements like what is described here, in conjunction with including the identifier on the CC).

The Sector believes that we should work towards language that would include a requirement similar to the International Organization of Legal Metrology (OIML) requirement in NIST Handbook 44. It is also the opinion of the Sector that a specific method should not be defined; rather the manufacturer should utilize a method and demonstrate the selected identification mechanism is suitable for the purpose. It is not clear from the discussion where such proposed language might belong.

NTEP strongly recommends that metrological software be separated from non-metrological software for ease of identification and evaluation.

From OIML:

Separation of software parts – All software modules (programmes, subroutines, objects etc.) that perform metrologically significant functions or that contain metrologically significant data domains form the metrologically significant software part of a measuring instrument (device or sub-assembly). The conformity requirement applies to all parts and parts shall be marked according to Section G-S-X.X.

If the separation of the software is not possible or needed, then the software is metrologically significant as a whole.

(Segregation of parameters is currently allowed – see table of sealable parameters)

Initial draft proposed language: (G-S.1.1?)

NIST Handbook 44 (This has been written into G-S.1.(d)(3): Identification of Certified Software:

Software-based electronic devices shall be designed such that the metrologically significant software is clearly identified by the version or revision number. The identification, and this identification of the software shall be inextricably directly and inseparably linked to the software itself. The version or revision number may consist of more than one part, but at least one part shall be dedicated to the metrologically significant software.

From NCWM Publication 14:

Identification of Certified Software:

Note: Manufacturers may choose to separate metrologically significant software from non-metrologically significant software. Separation would allow the revision of the non-metrological portion without the need for further evaluation. In addition, non-metrologically significant software may be updated on devices without breaking a seal, if so designed. Separation of software requires that all software modules (programs, subroutines, objects etc.) that perform metrologically significant functions or that contain metrologically significant data ~~domains~~ form the metrologically significant software part of a measuring instrument (device or sub-assembly). If the separation of the software is not possible or needed, then the software is metrologically significant as a whole. ~~The conformity requirement applies to all parts and parts shall be marked according to Section G-S.X.X.~~

The manufacturer must describe and possibly demonstrate how the version or revision identifier is directly and inseparably linked to the metrologically significant software. Where the version revision identifier is comprised of more than one part, the manufacturer shall describe which portion represents the metrological significant software and which does not.

From OIML D-31:

Legally relevant software of a measuring instrument/electronic device/sub-assembly shall be clearly identified with the software version or another token. The identification may consist of more than one part but at least one part shall be dedicated to the legal purpose.

The identification shall be inextricably linked to the software itself and shall be presented or printed on command or displayed during operation or at start up for a measuring instrument that can be turned off and on again. If a sub-assembly/an electronic device has neither display nor printer, the identification shall be sent via a communication interface in order to be displayed/printed on another sub-assembly/electronic device.

The first sentence of the first paragraph above is already addressed in NIST Handbook 44's marking requirements.

In 2010, the Sector recommended the following change to NIST Handbook 44, General Code: G-S.1(d) to add a new subsection (3):

(d) *the current software version or revision identifier for ~~not-built-for-purpose~~ software-based electronic devices;*

[Nonretroactive as of January 1, 2004]

(Added 2003) **(Amended 20XX)**

(1) *The version or revision identifier shall be prefaced by words, an abbreviation, or a symbol, that clearly identifies the number as the required version or revision.*

[Nonretroactive as of January 1, 2007]

(Added 2006)

(2) *Abbreviations for the word "Version" shall, as a minimum, begin with the letter "V" and may be followed by the word "Number." Abbreviations for the word "Revision" shall, as a minimum, begin with the letter "R" and may be followed by the word "Number." The abbreviation for the word "Number" shall, as a minimum, begin with the letter "N" (e.g., No or No.).*

[Nonretroactive as of January 1, 2007]

(Added 2006)

(3) The version or revision identifier shall be directly and inseparably linked to the software itself. The version or revision identifier may consist of more than one part, but at least one part shall be dedicated to the metrologically significant software.

[Nonretroactive as of January 1, 201X]

(Added 20XX)

Also the Sector recommended the following information be added to NCWM Publication 14 as explanation/examples:

- Unique identifier must be displayable/printable on command or during operation, etc.
- At a minimum, a version/revision indication (1.02.09, rev 3.0 a, etc.). Could also consist of/contain checksum, etc. (crc32, for example).

There was some additional discussion on this item regarding where this new requirement was best located. It was suggested that the first sentence of G-S.1.(d)(3) could be added as a clause to the base paragraph G-S.1.(d) text, for example, “*the current software version or revision identifier for ~~not-built-for-purpose-software-based~~ devices, which shall be directly and inseparably linked to the software itself.*”.

It also was suggested that the second sentence in G-S.1.(d)(3) might be more suitable for NCWM Publication 14, as it describes more “how” than “what” the requirement entails.

In addition, the Sector considered the following information to be added to NCWM Publication 14 as explanation/examples:

- The current software identifier must be displayable/printable on command during operation (or made evident by other means deemed acceptable by G-S.1.).
- At a minimum, the software identifier must include a version/revision indication (1.02.09, rev 3.0 a, etc). It could also consist of/contain checksum, etc. (crc32, for example).
- The version or revision identifier may consist of more than one part, but at least one part shall be dedicated to the metrologically significant software.

Other questions still outstanding:

- If we allow hard-marking of the software identifier (the Sector has wavered on this in the past), does the above wording then imply that some mechanical means is required (i.e., physical seal) to “inseparably link” the identifier to the software?
- If a device is capable of doing so, does it still have to be able to display, print or communicate the identifier somehow, even if it is hard-marked?

At the 2012 NTETC Software Sector Meeting, there was some discussion as to where the terminology regarding inextricably linking the software version or revision to the software itself belonged. At the moment, it is not incorporated in the proposed text for G-S.1. NCWM Publication 14 may be a better option for the time being. This would be another item that would benefit from further explanation in a supplementary document.

Several Sector members were of the opinion that attempting to make this change at the same time as the earlier changes might be a difficult sell. Mr. Truex, NTEP Administrator, reiterated the necessity of baby steps.

In 2012, the Sector thus recommended adding the following to NCWM Publication 14 and forward to NTETC Weighing, Measuring, Grain Analyzer Sectors for feedback:

Identification of Certified Software:

Note: Manufacturers may choose to separate metrologically significant software from non-metrologically significant software. Separation would allow the revision of the non-metrological portion without the need for

further evaluation. In addition, non-metrologically significant software may be updated on devices without breaking a seal, if so designed. Separation of software requires that all software modules (programs, subroutines, objects etc.) that perform metrologically significant functions or that contain metrologically significant data domains form the metrologically significant software part of a measuring instrument (device or sub-assembly). If the separation of the software is not possible or needed, then the software is metrologically significant as a whole. The conformity requirement applies to all parts and parts shall be marked according to Section G-S-X.X.

The manufacturer must describe and possibly demonstrate how the version or revision identifier is directly and inseparably linked to the metrologically significant software. Where the version revision identifier is comprised of more than one part, the manufacturer shall describe which portion represents the metrological significant software and which does not.

Discussion:

The Measuring Sector reviewed this item and had no feedback other than a statement that they support the continuing/ongoing efforts of this sector. The Weighing Sector summary mentioned that no one opted to provide comment. They agreed to take no further action on this item, pending further action from the Software Sector. This was specifically in reference to the accepted symbols.

For the time being, Jim Truex recommended that we not attempt to provide a definition for “software-based device.” We discussed the possibility of combining this change with the first agenda item, which had been attempted in previous years. Alternatively, if the NIST Handbook 44 changes from agenda Item 1 are made, this agenda item could be addressed in NCWM Publication 14.

Conclusion:

After further discussion, the wording in G-S.1.(d) under agenda item 1 was changed. Agenda Item 2 will remain; however, it will address potential changes to NCWM Publication 14 and contain no suggested modifications to NIST Handbook 44. (See changes and conclusion under agenda Item 1 for further details.)

The Sector Chair volunteered to review the existing slide presentation detailing the purpose of these changes, to ensure that it accurately reflects this information.

The list of acceptable menu text and symbols in Appendix A are intended to assist the labs in finding the certification number. The Sector noticed no action by the Sectors had been taken when this list was circulated for comment. We would like to remind them that we would like to have it reviewed. We feel that this belongs in, for example, the Weighing Device Publication 14, page DES-22, Section 3; the Belt-Conveyor Scales, page BCS-10, Section 8.7; the Measuring Devices, page LMD-21, Section 1.6; the Grain Moisture Meter, page GMM-14, Section 1 (G.S.1.); and Near Infrared Grain Analyzers, page NIR-8, Section 1 (G.S.1.).

3. Software Protection/Security

Source:

NTETC Software Sector

Background:

The Sector agreed that NIST Handbook 44 already has audit trail and physical seal, but these may need to be enhanced.

From the WELMEC Document:

Protection against accidental or unintentional changes:

Metrologically significant software and measurement data shall be protected against accidental or unintentional changes.

Specifying Notes:

Possible reasons for accidental changes and faults are: unpredictable physical influences, effects caused by user functions and residual defects of the software even though state-of-the-art development techniques have been applied.

This requirement includes consideration of:

- a) Physical influences: Stored measurement data shall be protected against corruption or deletion when a fault occurs or, alternatively, the fault shall be detectable.
- b) User functions: Confirmation shall be demanded before deleting or changing data.
- c) Software defects: Appropriate measures shall be taken to protect data from unintentional changes that could occur through incorrect program design or programming errors, e.g. plausibility checks.

Required Documentation:

The documentation should show the measures that have been taken to protect the software and data against unintentional changes.

Example of an Acceptable Solution:

- The accidental modification of software and measurement data may be checked by calculating a checksum over the relevant parts, comparing it with the nominal value and stopping if anything has been modified.
- Measurement data are not deleted without prior authorization, for example, a dialogue statement or window asking for confirmation of deletion.
- For fault detection see also Extension I.

The Sector continued to develop a proposed checklist for NCWM Publication 14. The numbering will still need to be added. This is based roughly on R 76-2 checklist and discussions beginning as early as the October 2007 NTETC Software Sector Meeting. The information requested by this checklist is currently voluntary; however, it is recommended that applicants comply with these requests or provide specific information as to why they may not be able to comply. Based on this information, the checklist may be amended to better fit with NTEP's need for information and the applicant's ability to comply.

The California, Maryland, and Ohio laboratories agreed to use this checklist on one of the next devices they have in the lab and report back to the sector on what the problems may be. In February 2011, the North Carolina laboratory was also given a copy of the checklist to try.

1. Devices with ~~Embedded Software~~ TYPE P (~~aka built for purpose~~)

- 1.1. Declaration of the manufacturer that the software is used in a fixed hardware and software environment. **AND** Yes No N/A
- 1.2. Cannot be modified or uploaded by any means after securing/verification. Yes No N/A
Note: It is acceptable to break the "seal" and load new software, audit trail is also a sufficient seal.
- 1.3. The software documentation contains:
- 1.3.1. Description of all functions, designating those that are considered metrologically significant. Yes No N/A
- 1.3.2. Description of the securing means (evidence of an intervention). Yes No N/A
- 1.3.3. Software Identification, **including version / revision** Yes No N/A
- 1.3.4. Description how to check the actual software identification. Yes No N/A
- 1.4. The software identification is:
- 1.4.1. Clearly assigned to the metrologically significant software and functions. Yes No N/A
- 1.4.1. Description how to check the actual software identification. Yes No N/A
- 1.4.2. Provided by the device as documented. Yes No N/A
- 1.4.3. **Directly linked to the software itself.** Yes No N/A

2. ~~Personal Computers, Instruments with PC Components, and Other Instruments, Devices, Modules, and Elements with Programmable or Loadable Metrologically Significant Software~~ TYPE U (~~aka not built for purpose~~)

- 2.1. The metrologically significant software is:
- 2.1.1. Documented with all relevant (see below for list of documents) information. Yes No N/A
- 2.1.2. Protected against accidental or intentional changes. Yes No N/A
- 2.2. Evidence of intervention (such as, changes, uploads, circumvention) is available until the next verification / inspection (e.g., physical seal, Checksum, **Cyclical Redundancy Check** (CRC), audit trail, etc. means of security). Yes No N/A

3. Software with ~~Closed Shell~~ (no access to the operating system and/or programs possible for the user)

- 3.1. Check whether there is a complete set of commands (e.g., function keys or commands via external interfaces) supplied and accompanied by short descriptions. Yes No N/A
- 3.2. Check whether the manufacturer has submitted a written declaration of the completeness of the set of commands. Yes No N/A

4. Operating System and/or Program(s) Accessible for the User

- 4.1. Check whether a checksum or equivalent signature is generated over the machine code of the metrologically significant software (program module(s) subject to legal control Weights and Measures jurisdiction and type-specific parameters). Yes No N/A

- 4.2. Check whether the metrologically significant software will detect and act upon any unauthorized alteration of the metrologically significant software using simple software tools (e.g., text editor). Yes No N/A

5. Software Interface(s)

- 5.1. Verify the manufacturer has documented:
- 5.1.1. The program modules of the metrologically significant software are defined and separated. Yes No N/A
 - 5.1.2. The protective software interface itself is part of the metrologically significant software. Yes No N/A
 - 5.1.3. The functions of the metrologically significant software that can be accessed via the protective software interface. Yes No N/A
 - 5.1.4. The parameters that may be exchanged via the protective software interface are defined. Yes No N/A
 - 5.1.5. The description of the functions and parameters are conclusive and complete. Yes No N/A
 - 5.1.6. There are software interface instructions for the third-party (external) application programmer. Yes No N/A

The Maryland laboratory had particular questions regarding 3.1 and 5.1. The information for 3.1 could be acquired from an operator's manual, a training video, or in-person training. The items in 5.1 were confusing to the evaluators. The terminology is familiar to software developers, but not necessarily others. It was indicated that manufacturers were typically quick to return the filled out questionnaire, but he didn't know how his laboratory was supposed to verify that it was true. Generally, the laboratories wouldn't be expected to verify things to that level. For example, if the manufacturer states that a checksum is used to ensure integrity, the laboratories wouldn't be expected to evaluate the algorithm used.

The intent was to see whether the manufacturer had at least considered these issues, not for evaluators to become software engineers. Perhaps a glossary or descriptive paragraphs might be added to assist the evaluators for if the manufacturer has questions for the evaluators.

OIML makes use of supplementary documents to explain the checklist they use. Below are links:

<http://www.oiml.org/publications/D/D031-e08.pdf>

<http://www.welmec.org/latest/guides/72.html>

http://www.welmec.org/fileadmin/user_files/publications/2-3.pdf

WELMEC document 2.3 is the original source for our checklist, but it's been significantly revised and simplified. Mr. Payne, Maryland Department of Agriculture, is going to review the other documents and come up with some suggestions for the checklist. Mr. Roach, California Division of Measurement Standards, is going to begin using the checklist. The international viewpoint is that any device running an operating system is considered to be Type U. Mr. Roach mentioned that they're having lots of problems with "skimmers" stealing PIN's. Is there some way they can detect this?

Mr. Lewis, Rice Lake Weighing Systems, Inc., mentioned that he liked Measurement Canada's website. When answering similar questions, different pages would appear, based on answers to those questions: <http://www.ic.gc.ca/eic/site/mc-mc.nsf/eng/lm00573.html>

At the 2011 NTETC Software Sector Meeting, the laboratories were polled to obtain any feedback on the use of the checklist. Maryland attempted to use this checklist a few times. They had some difficulty obtaining answers from the manufacturers because the individual(s) interacting with the Maryland evaluator didn't always have the required information on-hand. More experience in using the checklist will help determine what needs to be revised.

It was suggested that the checklist could be sent to manufacturers for their feedback as well, with the stipulation that it a completely voluntary exercise and purely informational at this point. The laboratories will coordinate with willing manufacturers to obtain feedback.

Work is ongoing on this item with the intent that it eventually will be incorporated as a checklist in NCWM Publication 14; again the laboratories are requested to try utilizing this checklist for any evaluations on software-based electronic devices.

The checklist has been reviewed with an eye to making its terminology clearer to laboratories. Some examples and clarifications have been added as shown in the discussion section of this item. The revised checklist will be distributed to the laboratories for additional review. Maryland and California laboratories agreed to use the checklist on a trial basis.

Discussion:

Over the past year, attempts to use the current checklist did not meet with many difficulties. The checklists were given to the manufacturers to fill out, and that seemed to work rather well. Minor modifications (in red above) were made to clarify certain confusing areas or eliminate redundancy.

Conclusion:

The next step will be to forward it to the four sectors; we can report that the labs have tried using it on a trial basis and we're ready to recommend it for NCWM Publication 14 with the modification suggested here, such as the removal of the Type P/Type U wording.

4. Software Maintenance and Reconfiguration

Source:

NTETC Software Sector

Background:

After the software is completed, what do the manufacturers use to secure their software? The following items were reviewed by the sector. *Note agenda Item 3 also contains information on Verified and Traced updates and Software Log.*

1. Verify that the update process is documented. (OK)
2. For traced updates, installed Software is authenticated and checked for integrity.

Technical means shall be employed to guarantee the authenticity of the loaded software (i.e., that it originates from the owner of the type approval certificate). This can be accomplished (e.g. by cryptographic means like signing). The signature is checked during loading. If the loaded software fails this test, the instrument shall discard it and either use the previous version of the software **or become inoperative.**

Technical means shall be employed to guarantee the integrity of the loaded software (i.e. that it has not been inadmissibly changed before loading). This can be accomplished in other words by adding a checksum or hash code of the loaded software and verifying it during the loading procedure. If the loaded software fails this test, the instrument shall discard it and either use the previous version of the software **or become inoperative.**

Examples are not limiting or exclusive.

3. Verify that the sealing requirements are met.

The Sector asked, "What sealing requirements are we talking about?"

This item is **only** addressing the **software update**, it can be either verified or traced. It is possible that there are two different security means, one for protecting software updates (software log) and one for protecting the other

metrological parameters (Category I, II, or III method of sealing). Some examples provided by the Sector members include but are not limited to:

- Physical seal, software log
- Category III method of sealing can contain both means of security

4. Verify that if the upgrade process fails, the device is inoperable or the original software is restored.

The question before the group is, can this be made mandatory?

The manufacturer shall ensure by appropriate technical means (e.g., an audit trail) that traced updates of metrologically significant software are adequately traceable within the instrument for subsequent verification and surveillance or inspection. This requirement enables inspection authorities, which are responsible for the metrological surveillance of legally controlled instruments, to back-trace traced updates of metrologically significant software over an adequate period of time (that depends on national legislation). The statement in italics will need to be reworded to comply with U.S. weights and measures requirements.

The Sector **agreed** that the two definitions below for Verified Update and Traced Update were acceptable.

Verified Update

A verified update is the process of installing new software where the security is broken and the device must be re-verified. Checking for authenticity and integrity is the responsibility of the owner/user.

Traced Update

A traced update is the process of installing new software where the software is automatically checked for authenticity and integrity, and the update is recorded in a software update log or audit trail.

Note: It's possible that the Philosophy of Sealing section of NCWM Publication 14 may already address the above IF the definitions of Verified and Traced Updates (and the statement below) were to be added. The contrary argument was that it may be better to be explicit).

Use of a Category 3 audit trail is required for a Traced Update. A log entry representing a traced software update shall include the software identification of the newly installed version.

The Sector recommended consolidating the definitions with the above statement thus:

Verified Update

A verified update is the process of installing new software where the security is broken and the device must be re-verified. Checking for authenticity and integrity is the responsibility of the owner/user.

Traced Update

A traced update is the process of installing new software where the software is automatically checked for authenticity and integrity, and the update is recorded in a ~~software update log or~~ Category 3 audit trail. The audit trail entry shall include the software identification of the newly installed version.

In 2012, the Sector recommended that as a first step, the following be added to NCWM Publication 14:

The updating of metrologically significant software, including software that checks the authenticity and integrity of the updates, shall be considered a sealable event.

Mr. Truex, NTEP Administrator, indicated his opinion that the above sentence is unnecessary since it's self-evident. It was agreed by the group however to ask the other sectors for feedback on the value of this addition.

Though the Sector is currently considering only the single sentence be incorporated into NCWM Publication 14 for the time being, ultimately, the Sector may wish to advance the remaining language of the original item submission.

Discussion:

The Sector had no information indicating that the other sectors had yet been approached for feedback on the value of the addition of the proposed sentence.

Conclusion:

This sector would like the other sectors to evaluate this for inclusion in Publication 14. We'd also like to include some description indicating that an existing audit trail should be protected during a software update, though that may already be a requirement. This does appear to be addressed in the Requirements for Metrological Audit Trails Appendices in NCWM Publication 14.

5. NTEP Application for Software and Software-based Devices

Source:

NTETC Software Sector

Background/Discussion:

The purpose of initiating this item was to identify issues, requirements, and processes for type approving Type U device applications. It was suggested that it may be useful to the labs to devise a separate submission form for software for Type U devices. What gets submitted? What requirements and mechanisms for submission should be available? Validation in the laboratories – all required subsystems shall be included to be able to simulate the system as installed.

Mr. Roach, California Division of Measurement Standards, stated that if the software package being evaluated supports platforms/subsystems from multiple manufacturers, testing should be done using at least two platforms/subsystems. Scale laboratories and scale manufacturers indicated that this is not usually done for scale evaluations.

Since the NTEP Committee passed the related item at NCWM Annual Meeting, we will continue to work on this. Mr. Truex, NTEP Administrator, indicated that we can move in this direction, but felt that it was somewhat premature to develop this thoroughly now. At the point where the Sector has developed checklist requirements, then we could move to perhaps add a subsection to current NTEP applications for applicable software. Refer to D-31.6.1. It was also agreed that there seems to be no reason for limiting the scope of this item to software-only applications, and, hence, all software/software-based devices could benefit from an enhanced application process. Hence, the description of this agenda item was modified as shown in the marked up heading.

Comments given at the meeting indicate that current practice does not require anything different for software/software based devices compared to any other type approval. It was also noted that for international applications, OIML D-31.6.5 states, "The approval applicant is responsible for the provision of all the required equipment and components." This would likely also be the policy of NTEP.

Since the checklist is still being tried out by some of the laboratories, the Sector is not quite ready to develop this fully. Some documentation that eventually might be required by applicants could include (from WELMEC doc. 7-2, Issue 4):

- A description of the software functions that are metrologically significant, meaning of the data, etc.
- A description of the accuracy of the measuring algorithms (e.g., price calculation and rounding algorithms).
- A description of the user interface, menus, and dialogs.
- **A description of the method of sealing.**
- The software identification (version, revision, etc.) and how to view it.
- An overview of the system hardware, for example topology block diagram, type of computer(s), type of network, etc, if not described in the operating manual.

- An overview of the security aspects of the ~~operating system~~ **software** (e.g. protection, user accounts, privileges, etc).
- The operating manual.

Conclusion:

The Sector recommends including the above bulleted list as an introduction to the checklist as part of our recommendation to include the checklist from Agenda Item 3 in NCWM Publication 14. As a description of the accuracy of the measuring algorithms, simply declaring the type and class being aimed for may be sufficient. This list should reflect the needs of the labs for an evaluation. The bulleted list and the paragraph before it should be brought to the labs for an initial review and their input.

6. Training of Field Inspectors

Source:

NTETC Software Sector

Background:

During discussions at the 2009 NTETC Software Sector Meeting, the Sector concluded that a new agenda item should be initiated specific to the training of field inspectors in relation to evaluating/validating software-based devices.

California has an Examination Procedure Outline (EPO) that begins to address this. Use California Handbook 112 as a pattern template for how it could read.

Items to be addressed:

- Certificate of Conformance (CC)
- Terminology (as related to software) beyond what is in NIST Handbook 44.
- Reference materials/information sources
- ~~Safety~~

System Verification Tests:

NOTE: Item numbers 1 through 5 apply to both weighing and measuring devices. Numbers 6 and 7 are specific to weighing devices; while numbers 9 and 10 apply to measuring devices.

1. Identification. The identification (ID) tag may be on the back room computer server and could be viewed on an identification screen on the computer monitor. The ID information may be displayed on a menu or identification screen. Though currently discouraged, some systems may be designed so the system must be shut down and reset to view the ID information. G-S.1. [1.10]
 - 1.1. Manufacturer.
 - 1.2. Model designation.
2. Provisions for sealing. G-S.8. [1.10]; S.1.11 [2.20]; S.2.2 [3.30]
 - 2.1. Verify sealing category of device (refer to Certificate of Approval for that system).
 - 2.2. Verify compliance with certificate.
3. Units of measure.
 - 3.1. A computer and printer interfaced to a digital indicator shall print all metrological values, intended to be the same, identically. G-S.5.2.2.(a); G-S.5.1 [1.10]
 - 3.2. The unit of measure, such as lb, kg, oz, gal, qts, liters, or whatever is used, must agree.
4. Operational controls, indications and features (buttons and switches). Verify that application criteria and performance criteria are met (refer to Certificate of Approval).
 - 4.1. Any indication, operation, function, or condition must not be represented in a manner that interferes with the interpretation of the indicated or printed values.
5. Indications and displays.

5.1. Attempt to print a ticket. The recorded information must be accurate or the software must not process and print a ticket with erroneous data interpreted as a measured amount.

Weighing Devices

6. Motion detection.
 - 6.1. For railway track, livestock, and vehicle scales apply or remove a test load of at least 15d while simultaneously operating a print button, push-button tare or push-button zero. A good way to do this is to try to print a ticket while pulling the weight truck or another vehicle onto the scale. Recorded values shall not differ from the static display by more than 3d. Perform the test at 10 %, 50 % and 100 % of the maximum applied test load. S.2.5.1.(a) [2.20]; EPO NO. 2-3, 2.4
 - 6.2. For all other scales, apply or remove at least 5d. Printed weight values must agree with the static weight within 1d and must exactly agree with other indications. S.2.5.4.(b) [2.20]; EPO NO. 2-3, 2.4
7. Behind zero indication.
 - 7.1 Apply a load in excess of the automatic zero setting mechanism (AZSM) and zero the scale. S.2.1.3. [2.20]; EPO NO. 2-3, 2.4, 2.5.2
Example: On a vehicle scale have someone stand on the scale, then zero them off (AZSM is 3d). Remove the weight (person) and note the behind zero display (usually a minus weight value) or error condition.
 - 7.2. Attempt to print a ticket. With a behind zero condition, (manually or mechanically operated) a negative number must not be printed as a positive value.
8. Over capacity.
 - 8.1. Manually enter a gross weight if permissible or apply a test load in excess of 105% of the scale's capacity. S.1.7. [2.20]; S.1.12., UR.3.9. [2.20]
 - 8.2. Attempt to print a weight ticket. A system must not print a ticket if the manually entered weight or load exceeds 105 % of the scale capacity.

Measuring Devices

9. Motion detection.
 - 9.1. Initiate flow through the measuring element. Attempt to print a ticket while the product is flowing through the measuring chamber. The device must not print while the indication is not stable. S.2.4.1. (3.30)
10. Over capacity.
 - 10.1. Attempt to print a ticket in excess of the indicated capacity. A system must not print a ticket if the device is manually or mechanically operated in excess of the indicated value.

NOTE: Be aware of error codes on the indicator which may be interrupted as measured values.

Mr. Jordan, California Division of Measurement Standards, is already doing something similar, and he may be able to assist. Mr. Roach, California Division of Measurement Standards, will talk to him to see whether they're available. In addition, Mr. Parks, California Division of Measurement Standards, is based in Sacramento, California, and a potential resource. If the meeting is held in Sacramento next year, they may be able to attend.

Mr. Truex, NTEP Administrator, pointed out that the PDC would also be a valuable resource on this subject. Mr. Pettinato, Co-Chair, will contact them.

*NIST Handbook 112 – *Examination Procedure Outline for Commercial Weighing and Measuring Devices*.

Discussion:

The Sector would like to enlist field inspectors from a variety of states review California's *Handbook 112*, especially the excerpt above, to see if they think it would be of use to them. We'll obtain approval from California before we disseminate this documentation.

The PDC is focused on training sessions at the moment, so it's unsure how much time they'd have to review this currently.

There is a NIST/NCWM initiative on training. Dr. Thompson is going to bring this to their attention.

Aside from the general list of things to check, shown above, providing specific examples of scenarios they might encounter would likely be useful for field inspectors. A small working group, including Dr. Thompson, Mr. Ken Jones (or someone else from California), Mr. Jim Pettinato, (check with Mr. Don Onweiler) possibly other field inspectors, etc. would be best to generate some examples.

A list of terms and acronyms could prove quite useful – not just to field inspectors, but perhaps even more so for type evaluators. The following is not really a list of definitions so much as various explanations of terms:

- CRC: Cyclical Redundancy Check
- Checksum
- Embedded software
- Firmware
- Version/Revision/Software Identifier: One component of a software identifier might be analogous to a model number, another component might be a version/revision, and another component might be a checksum. To satisfy the identification requirement, at a minimum, you need an identifier analogous to the model and a version/revision. In a product that has multiple pieces of software, you might require multiple software identifiers. For purposes of this list, Version and Revision are used synonymously.
- The difference between a serial number and a version/revision: Serial numbers are unique identifiers for a physical product. Identical copies of software can exist on multiple physical pieces of equipment, so serial numbers aren't truly relevant to software. Instead, a version/revision number, tied to the software itself, is used to identify the differences between one set of software features and another. In summary, hardware needs a serial number, and software needs a version/revision number.
- Directly linked: Physical marking of hardware with a software version is useless as the software can be updated, in which case the physical marking would no longer be accurate. The preferred case is that the software self-identifies (displays version number, etc.) continuously or on demand. If the software changes, the version must change. There is an exception for situations where the device itself has no means to identify the software to the outside world, such as lacking a printer and a display.
- Hash: This is used for validation and verification that software and/or data is authentic and valid. A hash function is any algorithm or subroutine that maps large data sets of variable length to smaller data sets of a fixed length. Examples include CRC, checksum, LRC, etc. Hashes are used because there is a very low probability of two different data blocks having the same hash code.
- Signature
- Metrologically significant software: Software that calculates or affects features and/or measurements that are sealable.
- Software separation: Software can be divided into metrologically significant and non-metrologically significant sections. If it is, only metrologically significant software must be controlled. If separation is not employed, then the entire software is considered metrologically significant. "Controlled" implies that a separate software identifier for the metrologically significant software is used.
- Software update
- Sealable parameters: Reference Publication 14 typical features or parameters to be sealed. Note that the download of software is recommended to be considered a sealable parameter.
- User interface: An interface forming the part of the instrument or measuring system that enables information to be passed between a human user and the measuring instrument or its hardware or software parts, such as, switch, keyboard, mouse, display, monitor, printer, and touch-screen.
- Communications interface: An electronic, optical, radio, removable storage media, or other technical interface that enables information to be automatically passed between parts of measuring instruments, sub-assemblies, or external devices.

- Reset/reboot
- Non-volatile memory
- Flash
- Encryption
- Authentication: Affirmation that the source of the software or data was genuine and recognized. This can be done either via an authorized agent or via specific software techniques. Authentication is employed in order to prevent loading of malicious software into devices.
- Third-party software: Software that is loaded into the weighing or measuring system that was not provided by the original manufacturer.
- Program
- Subroutine

We will flesh out this list, adding some brief definitions and/or examples. It will then be circulated amongst this group for review, and for any additional terms that are identified as being potentially useful.

Mr. Doug Bliss suggested developing educational presentations on relatively small software subjects, for presentation at the conferences, to provide training. We'll check into availability of time slots. January or next July are probably the earliest opportunities. Potential topics might include:

- General "software isn't scary"
- Background on why the software sector exists and what we're trying to accomplish
- Something to tie into the training of field inspectors on software
- Software identification
- Teaching inspectors how to read a certificate, with an eye toward information pertaining to software

Conclusion:

The Sector sees value in assisting in the training of field inspectors on several fronts as indicated by the discussion at this year's meeting. Several initiatives will be floated amongst the NCWM community and the Sector will focus on those that seem to have the most interest/benefit to the Conference.

NEW ITEMS

7. Next Meeting

Background:

The Sector is on a yearly schedule for NTETC Software Sector Meetings. Mr. Truex, NTEP Administrator, will determine when the next meeting is possible. This year was California's turn in the rotation to host the meeting, but due to the uncertainty of New York's status as potential host, the meeting ended up being back in Ohio. Hence, New York and California again are possible locations for the 2014 meeting.

Albany, New York, and California remain under consideration, with New York being the first choice, preferably as late as possible in March.

8. 2013 NCWM Interim Meeting Report

There was one item on the NCWM S&T Committee Agenda for the 2012 NCWM Interim Meeting related to work done by the NTETC Software Sector. 2012 NCWM Publication 15, S&T Item 360-2 relates to the 2012 NTETC Software Sector Agenda Item 1: Marking Requirements.

The Sector was informed of the S&T Committee decision to continue Item 360-2 as a Developing item.

9. 2013 International Report

Dr. Ambler Thompson, NIST, Office of Weights and Measures (OWM), will provide a synopsis of international activity that relates to the work of the Sector. Software Sector Co-Chair, Mr. Jim Pettinato, will summarize the discussion that took place at the European Cooperation in Legal Metrology (WELMEC) WG7 meeting in December 2011.

Highlights of interest to the NTETC Software Sector:

- New WELMEC 7.2 draft document circulated for comment by WG7
- R-117 working group

10. 360-7 D Appendix D – Definitions: Remote Configuration Capability

Source:

NTETC Grain Analyzer Sector (2013)

Purpose:

Expand the scope of definition to cover instances where the “other device” as noted in the current definition, may be necessary to the operation of the weighing or measuring device or which may be considered a permanent part of that device.

Item Under Consideration:

This item is under development. Comments and inquiries may be directed to NIST Office of Weights and Measures.

A proposal to modify the definition for “remote configuration capability” as follows is under consideration:

remote configuration capability. – The ability to adjust a weighing or measuring device or change its sealable parameters from or through some other device that ~~is not~~ **may or may not** itself **be** necessary to the operation of the weighing or measuring device or ~~is not~~ **may or may not be** a permanent part of that device.[2.20, 2.21, 2.24, 3.30, 3.37, 5.56.(a)]

(Added 1993, **Amended 20XX**)

Background/Discussion:

Removable digital storage devices can be used in GMMs as either data transfer devices that are not necessary to the operation of the GMM or as data storage devices which are necessary to the operation of the GMM. If removal data storage devices are necessary to the operation of the device, they are not covered by the current definition of remote configuration capability.

A USB flash drive is most likely to be used as a data transfer device. In a typical data transfer application, the USB flash drive is first connected to a computer with access to the GMM manufacturer’s web site to download the latest grain calibrations that are then stored in the USB flash drive. The USB flash drive is removed from the computer and plugged into a USB port on the GMM. The GMM is put into remote configuration mode to copy the new grain

calibration data into the GMM's internal memory. When the GMM has been returned to normal operating (measuring) mode, the USB flash drive can be removed from the GMM.

Although a Secure Digital (SD) memory card could also be used as a data transfer device, it is more likely to be used as a data storage device. In a typical "data storage device" application, the SD memory card stores the grain calibrations used on the GMM. The SD memory card must be plugged into an SD memory card connector on a GMM circuit card for the GMM to operate in measuring mode. To install new grain calibrations the GMM must be turned "off" or put into a mode in which the SD memory card can be safely removed. The SD memory card can either be replaced with an SD memory card that has been programmed with the new grain calibrations or the original SD memory card can be re-programmed with the new grain calibrations in much the same way as that described in the preceding paragraph to copy new grain calibrations into a USB flash drive. In either case, the SD memory card containing the new calibrations must be installed in the GMM for the GMM to operate in measuring mode. In that regard, the SD memory card (although removable) can be considered a permanent part of the GMM in that the GMM cannot operate without it.

Note: In the above example SD memory card could be any removable flash memory card such as the Secure Digital Standard-Capacity, the Secure Digital High-Capacity, the Secure Digital Extended-Capacity, and the Secure Digital Input/Output, which combines input/output functions with data storage. These come in three form factors: the original size, the mini size, and the micro size. A Memory Stick is a removable flash memory card format launched by Sony in 1998, and is also used in general to describe the whole family of Memory Sticks. In addition to the original Memory Stick, this family includes the Memory Stick PRO, the Memory Stick Duo, the Memory Stick PRO Duo, the Memory Stick Micro, and the Memory Stick PRO-HG.

At its 2011 Grain Analyzer Sector Meeting the Sector agreed by consensus that the following changes to Table S.2.5. of §5.56.(a) of NIST Handbook 44 should be forwarded to the S&T Committee for consideration:

- Add a note to Table S.2.5. to recognize the expanded scope of remote capability.
- Delete "remotely" from the second paragraph of Category 3 requirements that begins, "When accessedremotely ..." to make it clear that the requirements of Category 3 apply whether accessed manually using the keyboard or accessed by remote means.
- Add the modified second paragraph of Category 3 requirements to Categories 3a and 3b to make it clear that these requirements apply to all the subcategories of Category 3.

After additional review of this item, the NIST, OWM recommended that the changes to Table S.2.5. approved by the Sector in 2011 be separated into two independent proposals: one dealing with the changes to Category 3 and its subcategories and one recommending a modification of the definition of Remote Configuration Capability appearing in Appendix D of NIST Handbook 44 to recognize the expanded scope of remote capability, instead of adding a note to the bottom of Table S.2.5. to expanded the definition for remote configuration for grain moisture meters (as shown in this proposal). A change to the definition of remote configuration capability will apply to other device types.

2012 Grain Analyzer Sector Meeting: The sector agreed by consensus to separate its original proposal into two separate proposals and that this proposal to change the definition of Remote Configuration Capability should be forwarded to the S&T to Committee for consideration.

Item 5 of the NTETC, Grain Analyzer Sector August 2012 Meeting Summary covers this subject and will be available on NCWM Website, November 2012.

2012 NCWM Annual Meeting: Ms. Juana Williams NIST, OWM supported the intent. She talked about this item in conjunction with Item 356-1: S.2.5. Categories of Device and Methods of Sealing. This is such a complex item affecting multiple other devices; therefore, the proposal requires further consideration. The language in the proposal to amend the definition of remote configuration capability is confusing. The Committee believes the current definition already allows the use of remote configuration devices and allows the flexibility desired. The

ramifications of changing the definition could affect other devices in HB 44. WWMA did not forward this item to NCWM.

2012 SWMA Annual Meeting: There were no comments. After reviewing the proposal and considering the potential impact on other device types, the Committee recommended this as a Developing Item. The Committee asks that the Sector continue to obtain input on the definition and the impact the changes would have on other device types. SWMA forwarded the item to NCWM, recommending it as a Developing Item and assigning its development to the Grain Analyzer Sector.

During its Open Hearings at the 2013 NCWM Interim Meeting, the Committee heard comments from Ms. Juana Williams (NIST OWM). OWM suggests the Committee consider this item as a Developing Item to allow other Sectors to discuss how a change to the definition may affect other device types of similar design and to consider changes if needed. OWM recognizes that the current definition for “remote configuration capability” may not address those grain moisture meters (GMMs) which can only be operated with a removable data storage device, containing, among other things, the grain calibrations intended for use with the GMM, inserted in the device (as was described by the Grain Analyzer Sector). As such, OWM notes that current sealing requirements were developed at a time when such technology likely didn’t exist, nor could be envisioned, and are based on the current definition of remote configuration capability. Because the current definition was never intended to apply to this “next generation” technology, OWM suggests that those charged with further development of this item may wish to revisit the five philosophies of sealing and consider whether a new paragraph, completely separate from current sealing requirements, might be appropriate and a better option, than the one currently proposed. The five philosophies of sealing are included in the 1992 *Report of the 77th National Conference on Weights and Measures* (Report of the Specifications and Tolerances Committee). Another option, preferred over the changes currently proposed, would be to add a separate statement to the current definition of “remote configuration capability” to address removable storage devices. For example, the following sentence might be considered as an addition to the current definition for “remote configuration capability:”

Devices which are programmed using removable media (such as SD cards, flash drives, etc.) that may or may not be required to remain with the device during normal operation are also considered to be remotely configured devices.

The Committee also heard comments from Mr. Dmitri Karimov (LC), speaking on behalf of the MMA, who made two points: (1) Flow computers may already have these capabilities, thus it may be more appropriate to consider adding requirements to the General Code so that the requirements will be uniformly applied to all device types; and (2) the Committee should look ahead and consider other capabilities that may or already have emerged such as wireless communication and configuration.

The Committee acknowledged the comments indicating that the current definition of “remote configuration capability” was developed at a time when certain technologies, such as blue tooth, SD storage devices, flash drives, etc., didn’t exist. The Committee recognized it may be difficult to modify the existing definition and associated requirements to be flexible enough to address emerging and future technologies without having a significant (and possibly detrimental impact) on existing devices. Consequently, rather than modifying the current definition, the Committee concluded that a better approach might be to develop an entirely separate set of security requirements that would apply to emerging technologies. The Committee believes additional work is needed to develop proposed definition(s) and associated requirements and decided to designate the item as Developmental. The Committee requests other Sectors review the Grain Sector’s proposed modification to the definition as well as OWM’s suggestions and provide input.

Discussion:

Mr. Jim Pettinato and Mr. Doug Bliss suggested this alternative, possibly with the addition of some examples:

remote configuration capability. – The ability to adjust a weighing or measuring device or change its sealable parameters from or through some other device ~~that is not may or may not itself be necessary to the operation of the weighing or measuring device or is not may or may not be a permanent part of that device.~~[2.20, 2.21, 2.24, 3.30, 3.37, 5.56.(a)]

(Added 1993, Amended 20XX)

This proposal is technology-agnostic and addresses the concern that any revision of the definition would be tied to existing technology.

The Sector is curious as to how updates to the calibration parameters via either USB or SD cards are being handled to date. For example, when replacing an SD card, are the parameter changes being recorded in an audit trail?





Conclusion:

We will forward this comment to the S&T Committee and the Grain Analyzer Sector.

Appendix A

List of Acceptable Menu Text/Icons for Identification of Certificate Number

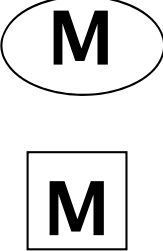
Table 1 - Software Sector Proposed Menu Text /Icons

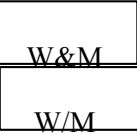
<i>Permitted Menu Text examples</i>	<i>Permitted Icon shape examples</i>	<i>Essential characteristics</i>
Information Info		Top level menu text or icon <ul style="list-style-type: none"> • Icon text is a lower case “i” with block serifs • Text color may be light or dark but must contrast with the background color • Icon may have a circular border • Activation of this menu text/icon may invoke a second level menu text/icon that recalls metrology information.
Help ?		Top level menu text or icon <ul style="list-style-type: none"> • Icon text is a question mark • Text color may be light or dark but must contrast with the background color • Icon may have a circular border • Activation of this menu text/icon may invoke a second level menu text/icon that recalls metrology information.
Metrology Metrological Information		Top or second level menu text or icon <ul style="list-style-type: none"> • Icon text is an upper case “M” • Text color may be light or dark but must contrast with the background color • Icon may have a circular, rectangular, or rounded rectangle border. • If present, the activation of this menu text/icon must recall at a minimum the NTEP CC number.
NTEP Data N.T.E.P. Certificate		This one is debatable – what if the certificate is revoked? Does NTEP grant holders of CCs the right to display the logo on the device, or just in documentation?
Weights & Measures Info		

THIS PAGE INTENTIONALLY LEFT BLANK

Appendix F

National Type Evaluation Technical Committee (NTETC) Weighing Sector Meeting Summary

August 27 - 28, 2013
Albany, NY

INTRODUCTION

The charge of the NTETC Weighing Sector is important in providing appropriate type evaluation criteria based on specifications, tolerances and technical requirements of NIST Handbook 44, *Specifications, Tolerances, and Other Technical Requirements for Weighing and Measuring Devices*, Sections 1.10. General Code, 2.20. Scales, 2.22. Automatic Bulk Weighing Systems, and 2.24. Automatic Weighing Systems. The Sector’s recommendations will be presented to the National Type Evaluation Program (NTEP) Committee each January for approval and inclusion in NCWM Publication 14, *Technical Policy, Checklists, and Test Procedures* for national type evaluation.

The Sector is also called upon occasionally for technical expertise in addressing difficult NIST Handbook 44, *Specifications, Tolerances, and Other Technical Issues* on the agenda of National Conference on Weights and Measures (NCWM) Specifications and Tolerances (S&T) Committee. Sector membership includes industry, NTEP laboratory representatives, technical advisors, and the NTEP Administrator. Meetings are held annually, or as needed and are open to all NCWM members and other registered parties.

Proposed revisions to the handbook(s) are shown as follows: 1) deleted language is indicated with a **bold face font using strikeouts** (e.g., ~~this report~~), 2) proposed new language is indicated with an **underscored bold faced font** (e.g., new items), and 3) nonretroactive items are identified in *italics*. There are instances where the Sector will use **red** text and/or **highlighted** text to bring emphasis to text that requires additional attention. When used in this report, the term “weight” means “mass.”

Note: It is the policy of the National Institute of Standards and Technology (NIST) to use metric units of measurement in all of its publications; however, recommendations received by NCWM technical committees and regional weights and measures associations have been printed in this publication as submitted. Therefore, the report may contain references in inch-pound units.

Table A
Table of Contents

Title of Contents	Page NTEP F
INTRODUCTION	1
CARRY-OVER ITEMS	3
1. Recommended Changes to NCWM Publication 14 Based on Actions at the 2013 NCWM Annual Meeting	3
1.a. Item 320-1 S.6.4. Railway Track Scales and Appendix D – Definitions.....	3
1.b. Item 320-4 Appendix C – Units of Mass (ton)	6
2. Acceptable Symbols/Abbreviations to Display the CC Number Via a Device’s User Interface	11
3. DES Section 70. – Performance and Permanence Tests for Railway Track Scales Used to Weigh In-Motion.....	15
4. NCWM Publication 14 Load Cell Table 6 – Summary Table Examples	16
NEW ITEMS	20

5. Item 360-7 NIST Handbook 44 Appendix D – Definitions: Remote Configuration Capability 20
 6. NCWM Publication 14 DES Section 76 Digital Controller Element for Load Cells Checklists and Test Procedures 22
 7. NCWM Publication 14 DES Checklists and Test Procedures Section 1 Marking – Applicable to Indicating, Weighing/Load-Receiving Elements and Complete Scales 24
 8. NCWM Publication 14 Load Cells – National Type Evaluation Program Terminology for Load Cell Parameters 24
 9. Identification of Certified Software 25
 10. Software Protection/Security 27
 11. Software Maintenance and Reconfiguration 30

ATTACHMENTS 33

Appendix

Appendix A - 2013 NTEP Weighing Sector Attendees (to be included in the Sector report)F / A34

**Table B
 Glossary of Acronyms and Terms**

Acronym	Term	Acronym	Term
ABWS	Automatic Bulk Weighing Systems	NEWMA	Northeastern Weights and Measures Association
AREMA	American Railway Engineering Maintenance-of-Way Association	NTEP	National Type Evaluation Program
AWS	Automatic Weighing Systems	OIML	International Organization of Legal Metrology
CC	Certificate of Conformance	OWM	Office of Weights and Measures
DES	Digital Electronic Scales	R	Recommendation
LMD	Liquid Measuring Device	S&T	Specifications and Tolerances Committee
MC	Measurement Canada	SMA	Scale Manufacturers Association
MRA	Mutual Recognition Agreement	WS	National Type Evaluation Program Weighing Sector
NCWM	National Conference on Weights and Measures		

Details of All Items
(In order by Reference Key)

CARRY-OVER ITEMS

1. Recommended Changes to NCWM Publication 14 Based on Actions at the 2013 NCWM Annual Meeting

Mr. Harshman, National Institute of Standards and Technology (NIST) Technical Advisor, provided the Sector with specific recommendations for incorporating test procedures and checklist language based upon actions of the 2013 NCWM Annual Meeting. The Sector was asked to briefly discuss each item and, if appropriate, provide general input on the technical aspects of the issues.

1.a. Item 320-1 S.6.4. Railway Track Scales and Appendix D – Definitions

Source:

2013 S&T Committee Final Report

Background/Discussion:

At the 2013 NCWM Annual Meeting, the NCWM voted to amend NIST Handbook 44 Scales Code paragraph S.6.4. Railway Track Scales and to add a new definition for “weigh module” to Appendix D. The following changes, included below in 1) and 2), were adopted:

1) Amend NIST Handbook 44 Scales Code paragraph S.6.4. Railway Track Scales. as follows:

S.6.4. Railway Track Scales. – A railway track scale shall be marked with the maximum capacity of each section of the load-receiving element of the scale. Such marking shall be accurately and conspicuously presented on, or adjacent to, the identification or nomenclature plate that is attached to the indicating element of the scale. ~~The nominal capacity of a scale with more than two sections shall not exceed twice its rated section capacity. The nominal capacity of a two section scale shall not exceed its rated section capacity.*~~

The nominal capacity marking shall satisfy the following:

(a) **For scales manufactured from January 1, 2002 through December 31, 2013:**

(1) **The nominal capacity of a scale with more than two sections shall not exceed twice its rated section capacity.**

(2) **The nominal capacity of a two section scale shall not exceed its rated section capacity.**

(b) **For scales manufactured on or after January 1, 2014, the nominal scale capacity shall not exceed the lesser of:**

(1) **The sum of the Weigh Module Capacities as shown in Table S.6.4.M. or Table S.6.4, or;**

(2) **Rated Sectional Capacity (RSC) multiplied by the Number of Sections (Ns) minus the Number of Dead Spaces (Nd) minus 0.5. As a formula this is stated as $RSC \times (Ns - Nd - 0.5)$; or**

(3) **290 300 kg (640,000 lb).**

*[*Nonretroactive as of January 1, 2002]*

(Amended 1988, 2001, ~~and 2002,~~ **and 2013**)

<u>Table S.6.4.M.</u>	
<u>Railway Track Scale – Weigh Module Capacity</u>	
<u>Weigh Module Length (m)</u>	<u>Weigh Module Capacity (kg)</u>
<u>< 1.5</u>	<u>36 300</u>
<u>1.5 to < 3.0</u>	<u>72 600</u>
<u>3.0 to < 4.5</u>	<u>108 900</u>
<u>4.5 to < 7.0</u>	<u>145 100</u>
<u>7.0 to < 9.0</u>	<u>168 700</u>
<u>9.0 to < 10.5</u>	<u>192 300</u>
<u>10.5 to < 12.0</u>	<u>234 100</u>
<u>12.0 to < 17.0</u>	<u>257 600</u>
<u>Note: The capacity of a particular module is based on its length and determined from corresponding capacity values specified in Table S.6.4.M.</u>	

(Table Added 2013)

<u>Table S.6.4.</u>	
<u>Railway Track Scale – Weigh Module Capacity</u>	
<u>Weigh Module Length (ft)</u>	<u>Weigh Module Capacity (lb)</u>
<u>< 5</u>	<u>80 000</u>
<u>5 to < 10</u>	<u>160 000</u>
<u>10 to < 15</u>	<u>240 000</u>
<u>15 to < 23</u>	<u>320 000</u>
<u>23 to < 29</u>	<u>372 000</u>
<u>29 to < 35</u>	<u>424 000</u>
<u>35 to < 40</u>	<u>516 000</u>
<u>40 to < 56</u>	<u>568 000</u>
<u>Note: The capacity of a particular module is based on its length and determined from corresponding capacity values specified in Table S.6.4.</u>	

(Table Added 2013)

- 2) Add the following definition for the term “weigh module” to NIST Handbook 44, Appendix D:

Weigh Module - The portion of a load-receiving element supported by two sections. The length of a module is the distance to which load can be applied. [2.20]

See the Final Report of the 2013 NCWM S&T Committee Agenda Item 320-1 for additional background information on this item to amend NIST Handbook 44 Scales Code paragraph S.6.4. Railway Track Scales and add a new definition for “weigh module” to NIST Handbook 44 Appendix D.

Conclusion:

The WS agreed to recommend two changes to NCWM Publication 14 DES as follows:

Change 1: Modify Section 1, the paragraph titled “For railway track and livestock scales” on page DES 17 of the 2013 edition as follows:

For railway track and livestock scales:

The nominal capacity of a scale with more than two sections shall not exceed twice its rated section capacity.

The nominal capacity of a two-section scale shall not exceed its rated section capacity.

For railway track scales the nominal scale capacity shall not exceed the lesser of:

- (1) **The sum of the Weigh Module Capacities as shown in Table S.6.4.M. or Table S.6.4, or;**
- (2) **Rated Sectional Capacity (RSC) multiplied by the Number of Sections (Ns) minus the Number of Dead Spaces (Nd) minus 0.5. As a formula this is stated as $RSC \times (Ns - Nd - 0.5)$; or**
- (3) **290 300 kg (640,000 lb).**

<u>Table S.6.4.M.</u>	
<u>Railway Track Scale – Weigh Module Capacity</u>	
<u>Weigh Module Length (m)</u>	<u>Weigh Module Capacity (kg)</u>
<u>< 1.5</u>	<u>36 300</u>
<u>1.5 to < 3.0</u>	<u>72 600</u>
<u>3.0 to < 4.5</u>	<u>108 900</u>
<u>4.5 to < 7.0</u>	<u>145 100</u>
<u>7.0 to < 9.0</u>	<u>168 700</u>
<u>9.0 to < 10.5</u>	<u>192 300</u>
<u>10.5 to < 12.0</u>	<u>234 100</u>
<u>12.0 to < 17.0</u>	<u>257 600</u>
<u>Note: The capacity of a particular module is based on its length and determined from corresponding capacity values specified in Table S.6.4.M.</u>	

Table S.6.4.	
Railway Track Scale – Weigh Module Capacity	
<u>Weigh Module Length (ft)</u>	<u>Weigh Module Capacity (lb)</u>
<u>≤ 5</u>	<u>80 000</u>
<u>5 to < 10</u>	<u>160 000</u>
<u>10 to < 15</u>	<u>240 000</u>
<u>15 to < 23</u>	<u>320 000</u>
<u>23 to < 29</u>	<u>372 000</u>
<u>29 to < 35</u>	<u>424 000</u>
<u>35 to < 40</u>	<u>516 000</u>
<u>40 to < 56</u>	<u>568 000</u>
Note: The capacity of a particular module is based on its length and determined from corresponding capacity values specified in Table S.6.4.	

Devices designed for special applications...

Change 2: Add a new Section 5.5. and accompanying checkboxes to the checklists and test procedures as shown below:

5.5 <u>The nominal scale capacity for railway track scales shall not exceed the lesser of (1) The sum of the Weigh Module Capacities as shown in Table S.6.4.M. or Table S.6.4, or (2) the Rated Sectional Capacity (RSC) multiplied by the Number of Sections (Ns) minus the Number of Dead Spaces (Nd) minus 0.5. As a formula this is stated as RSC x (Ns - Nd - 0.5), or (3) 290 300 kg (640,000 lb).</u>	<input type="checkbox"/> Yes <input type="checkbox"/> No <input type="checkbox"/> N/A
----------------------------------------------------------------------------------------------------------------------------------------------------------------------------------------------------------------------------------------------------------------------------------------------------------------------------------------------------------------------------------------------------------------------	---------------------------------------------------------------------------------------

NIST Technical Advisor’s note: With respect to Change 1, the WS concluded that it was not necessary in NCWM Publication 14 to differentiate between railway track scales manufactured as of January 1, 2014, and those manufactured prior to this date because Publication 14 checklists and procedures is only intended to apply to new equipment submitted for type evaluation. Thus, there is no need to include in Publication 14 the portion of the language that was adopted into NIST Handbook 44 at the 2013 NCWM Annual Meeting intended to apply to equipment manufactured from January 1, 2002 through December 31, 2013. With respect to Change 2, the Sector agreed that it was important to add a new Section 5.5. and accompanying checkboxes to alert NTEP evaluators of the changes that were adopted and to provide an area on the evaluation form to record whether or not equipment being evaluated complies.

1.b. Item 320-4 Appendix C – Units of Mass (ton)

Source:

Mr. Paul Lewis, Rice Lake Weighing Systems, Inc. (2011 NTETC Weighing Sector Agenda Item 8 and 2012 Weighing Sector Agenda Item 5)

Background/Discussion:

At its 2013 Annual meeting, the NCWM voted in favor of amending Appendix C – General Tables of Units of Measurement to recognize “tn” as an acceptable abbreviation for “net” or “short” ton and to add a new footnote, where appropriate, to make clear that abbreviations for “net” or “short” ton other than “tn” are considered acceptable for use with older equipment. The following changes were adopted:

- 1) Amend the Units of Mass Table on pages C-19 and C-20 of NIST Handbook 44, Appendix C to recognize “tn” as an acceptable abbreviation for “net” or “short” ton, and add a footnote to the table to make clear that abbreviations for “net” or “short” ton other than “tn” are considered appropriate for use with older equipment as follows:

Units of Mass	
1 assay ton ¹⁷ (AT)	29.167 grams
1 carat (c)	200 milligrams (exactly) 3.086 grains
1 dram apothecaries (dr ap or ℥)	60 grains (exactly) 3.888 grams
1 dram avoirdupois (dr avdp)	27 ¹¹ /32 (= 27.344) grains 1.772 grams
1 gamma (γ)	1 microgram (exactly)
1 grain	64.798 91 milligrams (exactly)
1 gram (g)	15.432 grains 0.035 ounce, avoirdupois
1 hundredweight, gross or long ¹⁸ (gross cwt)	112 pounds (exactly) 50.802 kilograms
1 hundredweight, gross or short (cwt or net cwt)	100 pounds (exactly) 45.359 kilograms
1 kilogram (kg)	2.205 pounds
1 milligram (mg)	0.015 grain
1 ounce, avoirdupois (oz avdp)	437.5 grains (exactly) 0.911 troy or apothecaries ounce 28.350 grams
1 ounce, troy or apothecaries (oz t or oz ap or ℥)	480 grains (exactly) 1.097 avoirdupois ounces 31.103 grams
1 pennyweight (dwt)	1.555 grams
1 point	0.01 carat 2 milligrams
1 pound, avoirdupois (lb avdp)	7000 grains (exactly) 1.215 troy or apothecaries pounds 453.592 37 grams (exactly)
1 micropound (μlb) [the Greek letter mu in combination with the letters lb]	0.000 001 pound (exactly)
1 pound, troy or apothecaries (lb t or lb ap)	5760 grains (exactly) 0.823 avoirdupois pound 373.242 grams
1 scruple (s ap or ℥)	20 grains (exactly) 1.296 grams
1 ton, gross or long ¹⁹	2240 pounds (exactly) 1.12 net tons (exactly) 1.016 metric tons
1 ton, metric (t)	2204.623 pounds 0.984 gross ton 1.102 net tons
1 ton, net or short (tn)^x	2000 pounds (exactly) 0.893 gross ton 0.907 metric ton

¹⁷ Used in assaying. The assay ton...

¹⁸ The gross or long ton and hundredweight are used commercially in the United States to only a very limited extent, usually in restricted industrial fields. The units are the same as the British “ton” and “hundredweight.”

¹⁹ The gross or long ton...

^xAs of January 1, 2014, “tn” is the required abbreviation for short ton. Devices manufactured between January 1, 2008 and December 31, 2013 may use an abbreviation other than “tn” to specify short ton.

- Amend the abbreviation “t” for 1 ton (20 hundredweights) beneath the Avoirdupois Units of Mass heading on page C-6 of NIST Handbook 44, Appendix C to “tn” and add the same footnote as is being added to the Units of Mass table to again make clear that abbreviations for “net” or “short” ton other than “tn” are considered appropriate for use with older equipment as follows:

Avoirdupois Units of Mass⁶

[The “grain” is the same in avoirdupois, troy, and apothecaries units of mass.]

1 μlb	= 0.000 001 pound (lb)
27 ^{11/32} grains (gr)	= 1 dram (dr)
16 drams	= 1 ounce (oz)
	= 437½ grains
16 ounces	= 1 pound (lb)
	= 256 drams
	= 7000 grains
100 pounds	= 1 hundredweight (cwt) ⁷
20 hundredweights	= 1 ton (t) (tn)^x
	= 2000 pounds ⁷

In “gross” or “long” measure, the following values are recognized:

112 pounds (lb)	= 1 gross or long hundredweight (cwt) ⁷
20 gross or long hundredweights	= 1 gross or long ton
	= 2240 pounds ⁷

⁶ When necessary to distinguish...

⁷ When the terms “hundredweight” and...

^xAs of January 1, 2014, “tn” is the required abbreviation for short ton. Devices manufactured between January 1, 2008 and December 31, 2013, may use an abbreviation other than “tn” to specify short ton.

Additional background information relating to this item is available from the following:

- 2012 and 2013 NCWM Final Reports: <http://www.ncwm.net/meetings/annual/archive>
- 2012 Weighing Sector Summary (Agenda Item 5) at: http://www.ncwm.net/resources/dyn/files/1060841z7afe16a7/fn/2012_Weighing_Sector_Meeting+Summary.pdf

Conclusion:

In discussing this item, the Sector agreed that the word “ton,” when used by itself (i.e., without further clarification identifying which ton is meant) to define a value indicated or recorded by a scale is intended solely to represent the U.S. short ton. Thus, the word “ton,” when used by itself, is not intended, nor should it be permitted, to define any other version (e.g. long ton, metric ton, etc.) of the ton unit. Based on this premise, the WS agreed to recommend amending NCWM Publication 14 DES Section 12. Values Defined as follows:

12. Values Defined

Code References: G-S.5.2.4., G-S.5.3.1., G-S.5.6. and G-S.5.6.1.

Graduations, indications, and recorded values that are intended to have specific values shall be adequately identified by a sufficient number of figures, words, and symbols. These defining terms shall be uniformly placed relative to the graduations, indications, and recorded values and as close as practical to them without interfering with their readability. When SI units are used, the symbols shall comply with those in Appendix C (General Tables of Units of Measurement) in NIST Handbook 44 or NIST Special Publication SP 811 *Guide for the Use of International System of Units (SI)*. Other symbols shall comply with the abbreviations given in Appendix C (General Tables of Units of Measurement) in NIST Handbook 44. Exceptions are the abbreviations for "carat" (c or ct), U.S. short ton (~~ton or~~ TN), U.S. "long ton" (LT), and "grain" in NCWM Publication 14, DES Section 76.

Additionally, the WS reviewed the list of acceptable abbreviations/symbols in Appendix C of NCWM Publication 14 DES and agreed to forward the following proposed changes to the NTEP Belt-Conveyor Scale (BCS) Sector for additional input with the understanding that these proposed changes, if adopted, would likely have a more significant impact on BCS manufacturers than manufacturers of other types of scales:

Appendix C Acceptable Abbreviations/Symbols

This list does not standardize the abbreviations/symbols that must be used, rather, it identifies abbreviations/symbols that are routinely acceptable. This list is not limiting or all-inclusive; other abbreviations/symbols may be acceptable.

Additionally, the following lists of abbreviations and symbols should be used as a guide; style differences are acceptable (e.g., shapes of arrows,)

Device Application	Term	Acceptable	<u>NOT</u> Acceptable
General	value of scale division (displayed)	d	
	value of verification scale division	e	
	number of scale divisions	n	
	gross	gross, G, GR	
	Semi-automatic (push-button) tare	tare, T, TA	
	Keyboard, Programmable and Stored tare	tare, T, TA, PT	
	net	net, N, NT	
	pieces	pieces pc, pcs	
	count	count cnt or pc(s) <i>is encouraged or ct symbol for pieces ct is acceptable NIST Handbook 130</i>	c
carat or carat troy – 200 mg	c <i>NIST Handbook 44 and NIST Guide for the Use of</i>	ct <i>not permitted if used as the abbreviation for carat and</i>	

NTEP Committee 2014 Final Report
Appendix F – 2013 Weighing Sector Summary

		<i>International System of Units (SI)</i>	<i>count on a scale with an enable count feature</i>
	short ton	ton or tn	
Values Defined	SI Units <i>Notes: Lower case "kg" on display panels and keys. Lower case "kg" shall be used for printing.</i>	<i>NIST Guide for the Use of International System of Units (SI)</i>	upper case "KG"
	Other Symbols	NIST Handbook 44, Appendix C – General Tables of Units of Measurement	
*Exceptions to General Tables of NIST Handbook 44	carat or carat troy – 200 mg	ct <i>common jewelry industry abbreviation and is the only acceptable abbreviation in Canada</i>	ct <i>not permitted if used as the abbreviation for carat and count on a scale with an enable count feature</i>
	U.S. short ton	ton, TN, or tn <i>for belt-conveyor scales the abbreviation "T" is acceptable</i>	
	U.S. long ton	LT	
	Grain	grain, GRN, grn, GN	
Weighing and Indicating Elements	accuracy class	I, II, III, III L, IIII or symbols enclosed in an ellipse such as:Ⓢ	1, 11, 111, 111 L, 1111, 1, 2, 3 L, 4
	maximum number of scale divisions	n _{max}	N
	section capacity	Sec C, Sec Cap	SC
Weighing/Load Receiving Elements	minimum value of verification scale division	e _{min}	E
Load Cells	maximum number of scale divisions	n _{max}	N
	single or multiple cell applications	S = Single M = Multiple	
	load cell verification interval	v _{min}	V
ECRs, Indicating and Recording Elements	manual weight entry	Manual weight, MAN, WT, MANUAL WT, MAN WEIGHT, similar statement	"M" or "MW"
	symbols for kilogram	Same as noted in Section 11. Values Defined	<i>mixed upper and lower case letters are not permitted</i>
ECRs, Recorded Representations	net weight indication in pounds	"pound" or "lb"	"#" symbol for pound

Livestock and Animal Scales	Head (sale by)	HB, H	
	Weight (sale by)	WT, W	
	other symbols recognized by the Packers and Stockyards Administration		
Prescription Filling Count Feature for Class I and II Scales	minimum piece weight	MPW	
	minimum sample size	MSS	
	minimum sample size in weight	MSSW	
Belt-Conveyor Scales	U.S. short ton (different from "General" application)	T	

2. Acceptable Symbols/Abbreviations to Display the CC Number Via a Device’s User Interface

Sources:

- 2009 NTETC Software Sector Agenda Item 3 and 2010 S&T Item 310-3, G-S.1. Identification. (Software)
- 2010 Final Report of the S&T Committee: ncwm.net/content/annual-archive
- 2010 Software Sector summary: <http://www.ncwm.net/committees/ntep/sectors/software/archive>
- 2011 Software Sector summary: <http://www.ncwm.net/committees/ntep/sectors/software/archive>
- 2011 Final Report of the S&T Committee (Publication 16 and addendum sheets): ncwm.net/content/annual-archive
- 2012 Software Sector summary: <http://www.ncwm.net/committees/ntep/sectors/software/archive>
- 2012 and 2013 Final Report of the S&T Committee: <http://www.ncwm.net/content/annual-archive>

Background/Discussion:

Local weights and measures inspectors need a means to determine whether equipment discovered in the field has been evaluated by NTEP. If so, the inspector needs to know at a minimum the CC number. From this starting point, other required information can be ascertained. NIST Handbook 44 currently includes three options for marking of the CC:

1. Permanent marking
2. Continuous display
3. Recall using a special operation

The following draft summary was provided by the chairman of the Software Sector and is being provided to update members of the Weighing Sector regarding the discussions/actions taken by the Software Sector during their 2013 meeting:

Since its inception the Sector has wrestled with the issue of software identification and marking requirements. See the 2012 Software Sector Meeting Summary and the 2013 Interim Meeting S&T Agenda Item 360-2 for more background on this item.

NIST OWM had been adding items to the S&T Agendas that confused matters since the perception was that this sector had contributed to this input. Most of the confusion arose in the 1990s, due to some items being approved, and others, such as the definitions for “Built-for-Purpose” and “Not-Built-for-Purpose,” not being approved.

Mr. Truex, NTEP Administrator, discussed the difficulty there has been in coming to a consensus on these issues with a representative of the NTEP Committee. Suggestions from NTEP to come to some resolution has been to write an article for the newsletter (which Mr. Bliss, Mettler-Toledo, LLC, had already done, to no effect), sending a questionnaire to the NTEP community, asking what they’d like to see, and sending a representative from this Sector to the S&T Committee.

Mr. Roach, California Division of Measurement Standards, is concerned that some people may want to interpret G-S.1.(c) as requiring a serial number for software. Mr. Lewis, Rice Lake Weighing Systems, Inc. pointed out that the computer that the software was running on could have the serial number, not the software itself. That shouldn’t matter, regardless.

Mr. Bliss, Mettler-Toledo, LLC, pointed out that the terminology in G-S.1. “All equipment”, could be interpreted to mean that it doesn’t apply to software. It was proposed that G-S.1.(c) be amended to add “and software”. Mr. Bliss suggested submitting a document explaining the reasoning behind the proposed changes, rather than assume that the text is self-explanatory. Making a presentation to the various committees on the subject in addition would be beneficial as well. If a document is written, perhaps the examples given in G-S.1.d.(3)(a) can be eliminated. “Metrologically significant” isn’t explicitly defined, but it’s been used since time immemorial.

Attempts to modify G-S.1.1. have been controversial, both in this meeting and in other committees. Unfortunately, there has been little constructive feedback from the other Committees. It would probably be easier to incorporate specific examples given in G-S.1.1.b.3 in NCWM Publication 14. After some discussion, the previously proposed language was modified slightly to address some of the concerns received via feedback from other sectors and interested parties:

NIST Handbook 44 – Proposed changes:

G-S.1. Identification. – All equipment, except weights and separate parts necessary to the measurement process but not having any metrological effect, shall be clearly and permanently marked for the purposes of identification with the following information:

- (a) the name, initials, or trademark of the manufacturer or distributor;
- (b) a model identifier that positively identifies the pattern or design of the device;

(1) The model identifier shall be prefaced by the word “Model,” “Type,” or “Pattern.” These terms may be followed by the word “Number” or an abbreviation of that word. The abbreviation for the word “Number” shall, as a minimum, begin with the letter “N” (e.g., No or No.). The abbreviation for the word “Model” shall be “Mod” or “Mod.” Prefix lettering may be initial capitals, all capitals, or all lowercase.

[Nonretroactive as of January 1, 2003]

(Added 2000) (Amended 2001)

- (c) a nonrepetitive serial number, except for equipment with no moving or electronic component parts and ~~not built for purpose software-based software devices software;~~
[Nonretroactive as of January 1, 1968]
(Amended 2003)
- (1) *The serial number shall be prefaced by words, an abbreviation, or a symbol, that clearly identifies the number as the required serial number.*
[Nonretroactive as of January 1, 1986]
- (2) *Abbreviations for the word “Serial” shall, as a minimum, begin with the letter “S,” and abbreviations for the word “Number” shall, as a minimum, begin with the letter “N” (e.g., S/N, SN, Ser. No., and S. No.).*
[Nonretroactive as of January 1, 2001]
- (d) the current software version or revision identifier ~~for not built for purpose software-based electronic devices,~~ **which shall be directly linked to the software itself;**
[Nonretroactive as of January 1, 2004]
(Added 2003) (**Amended 20XX**)
- (1) *The version or revision identifier shall be prefaced by words, an abbreviation, or a symbol, that clearly identifies the number as the required version or revision.*
[Nonretroactive as of January 1, 2007]
(Added 2006)
- (2) *Abbreviations for the word “Version” shall, as a minimum, begin with the letter “V” and may be followed by the word “Number.” Abbreviations for the word “Revision” shall, as a minimum, begin with the letter “R” and may be followed by the word “Number.” The abbreviation for the word “Number” shall, as a minimum, begin with the letter “N” (e.g., No or No.).*
[Nonretroactive as of January 1, 2007]
(Added 2006)
- (3) **The version or revision identifier shall be accessible via the display. Instructions for displaying the version or revision identifier shall be described in the CC. As an exception, permanently marking the version or revision identifier shall be acceptable under the following conditions:**
- (a) **The user interface does not have any control capability to activate the indication of the version or revision identifier on the display, or the display does not technically allow the version or revision identifier to be shown (analog indicating device or electromechanical counter) or**
- (b) **the device does not have an interface to communicate the version or revision identifier.**
- (e) an NTEP CC number or a corresponding CC Addendum Number for devices that have a CC.
- (1) *The CC Number or a corresponding CC Addendum Number shall be prefaced by the terms “NTEP CC,” “CC,” or “Approval.” These terms may be followed by the word “Number” or an abbreviation of that word. The abbreviation for the word “Number” shall, as a minimum, begin with the letter “N” (e.g., No or No.)*
[Nonretroactive as of January 1, 2003]

The required information shall be so located that it is readily observable without the necessity of the disassembly of a part requiring the use of any means separate from the device.

(Amended 1985, 1991, 1999, 2000, 2001, 2003, ~~and~~, 2006 **and 201X**)

G-S.1.1. Location of Marking Information for ~~Not Built For Purpose~~ All Software-Based Devices. —For ~~not built for purpose,~~ software-based devices, either:

- (a) *The required information in G-S.1. Identification. (a), (b), ~~(d)~~, and (e) shall be permanently marked or continuously displayed on the device; or*

(b) *The CC Number shall be:*

- (1) *permanently marked on the device;*
- (2) *continuously displayed; or*
- (3) *accessible through an easily recognized menu and, if necessary, a submenu. Examples of menu and submenu identification include, but are not limited to, "Help," "System Identification," "G-S.I. Identification," or "Weights and Measures Identification."*

Note: *For (b), clear instructions for accessing the information required in G-S.I. (a), (b), and (d) shall be listed on the CC, including information necessary to identify that the software in the device is the same type that was evaluated.*

[Nonretroactive as of January 1, 2004]

(Added 2003) (Amended 2006 **and 20XX**)

The new language in G-S.1.1. reflects that the sector reached consensus on the following positions:

- The software version/revision should (with very few exceptions – see D-31, 5.1.1.) be accessible via the user interface.
- The means by which the software version is accessed must be described in the Certificate of Conformance (CC).

The Sector promoted this item following the meeting via several means to try and address the concerns of other interested parties. A presentation was generated and shared with the SMA at their meeting. The regions had access to this information, as it was posted on the NCWM website. Unfortunately, based on the comments in the 2013 NCWM Publication 15, Item 360-2, some regions were not aware that this information had been provided.

During the 2013 NCWM Interim Meeting, no comments were received relative to this item during the Open Hearings. In considering the item, the Committee questioned whether or not the Software Sector was still actively working the item. It was reported that the Software Sector believed they had developed the item as much as possible, yet the different stakeholders affected by the proposal could not agree on the changes that the Sector had proposed. Based upon that update, the Committee agreed to add to its report a request that the Software Sector work with the Weighing Sector and Measuring Sector to identify which portions of the proposal need to be modified in order that they might be accepted by the entire community. The Committee acknowledges and appreciates the efforts of the Software Sector and looks forward to being able to consider a proposal that addresses both the identification of software and how it may be accessed.

Since the 2012 meeting, the Sector has attempted to promote this item via several means to try and address the concerns of other interested parties. A presentation was generated and shared with the SMA at their 2012 meeting. Most of the regions had access to this information prior to their meetings, as it was posted on the NCWM website. Unfortunately, based on the comments in the 2013 NCWM Publication 15, Item 360-2, some regions were not aware that this information had been made available. In addition, it was noted that it may be desirable to evaluate options that would lead to fully eliminating GS-1.1. It was noted that this would be a more invasive modification to the existing handbook and perhaps should be put off until the first step of addressing software in all devices (not just standalone) was accomplished.

The Sector considers this item sufficiently developed. The one response to our request for review/comment that contained negative feedback was undeniably vague and non-constructive. The issue seems to be more one of communication/understanding than disagreement with the intent or wording. We may want to consider more direct methods (i.e., designating a representative to address the regional groups or other Sectors at their meetings). The annual meeting may be an appropriate venue for a presentation.

To move this forward, someone should address the regional groups. There are five to six potential venues for presentations. The last slide from the current presentation should be eliminated, to avoid confusing matters, for the time being. The two regional meetings in the fall (Western and Southern) and the interim meeting are probably

more critical than the ones in May. Dr. Thompson was asked to relay that we have a presentation available and would like to push our proposal as a Voting item in 2014. To be part of the January 2014 Annual S&T Committee's hearings/agenda, this needs to be brought to Mr. Rick Harshman's attention. Dr. Thompson volunteered to speak with him.

After removing the "and inseparably" terminology from the proposal, the concerns on the possibility of controversy were reduced.

The Sector's opinion on the interpretation of "directly linked" is that it means that you can't change the version/revision without changing the software.

It was recommended that a couple examples be added to the current slide presentation, to illustrate the intent of the proposed changes. One example might be supermarket-specific software designed to run upon a cash register. Another example might be, after a software change, noting that the new software version/revision number is no longer the same, and the operator was not prompted to enter a version/revision number.

Additional background information relative to this item can be found in:

- 2013 NCWM Publication 16 (S&T Agenda Item 360-2) at:
http://www.ncwm.net/resources/dyn/files/1025938z8fff0401/fn/2013_ST_Pub16.pdf
- 2012 Software Sector Meeting Summary at:
http://www.ncwm.net/resources/dyn/files/981563zdcfef44f/fn/12_Software_Sector_Summary.pdf

Conclusion:

The WS was asked to review the updated draft summary provided by the chairman of the 2013 NTEP Software Sector and consider providing additional input as necessary. In considering the item, a comment was heard regarding whether or not a nonrepetitive serial number is needed for software. The example provided was two software applications running on a single PC interfaced with two weighing elements. The concern is how would an inspector know which weighing system he/she is evaluating. The Sector discussed this concern and agreed to forward it to the Software Sector and the S&T Committee for consideration.

3. DES Section 70. - Performance and Permanence Tests for Railway Track Scales Used to Weigh In-Motion

Source:

Mr. Ed Luthy, Stock Equipment Company, Inc. (2011 Weighing Sector Agenda Item 6 and 2012 Weighing Sector Agenda Item 3)

Background/Discussion:

During the 2011 NTEP Weighing Sector Meeting, the Sector discussed a weigh-in-motion system using new technology that utilizes continuous rails (no "rail gaps") on the approaches and weighing areas of the scale. The submitter stated that the manufacturer is currently unable to offer this device for sale in the United States in commercial applications because current NTEP type evaluation criteria and NIST Handbook 44 requirements are written in such a way that makes it impossible for devices incorporating this new technology to comply. For example, NIST Handbook 44 Scales Code paragraph UR.2.4. Foundations, Supports, and Clearance requires clearance be provided around all live parts to the extent that no contacts may result. NCWM Publication 14, DES Section 70, Inspect the Scale, Item 4 Rail Gaps states that "the rail gaps should be set at 3/8 inch." The AAR Scale Handbook includes language that allows 1/8 inch to 5/8 inch rail gaps.

Members of the Sector agreed that they were not willing to recommend deleting references to the required gaps in the rail until it is proven that the new technology complies with the tolerances in NIST Handbook 44. Thus, the Sector recommended that the applicant move forward with performance testing to confirm that the new technology complies with the tolerances in NIST Handbook 44. The Sector agreed that data resulting from the performance testing needed to be submitted to the Sector prior to the time that the 2012 NTEP Weighing Sector Agenda was

developed or the item should not be included as a Carry-over item on that agenda. However, the Sector later agreed to retain the item on its agenda in 2012, and again in 2013, even though no data had been submitted because it was reported that there existed an open NTEP application for the equipment and that testing was still ongoing.

For additional background information relative to this item and actions taken by the NTEP Weighing Sector during its 2011 and 2012 meetings go to: <http://www.ncwm.net/meetings/ntep/weighing/archive>.

Conclusion:

During the 2013 WS meeting, Mr. Luthy provided an update to members of the Sector on the progress of the NTEP evaluation of the equipment. He reported that an NTEP evaluator had recently completed both static and in-motion tests and that the device conformed to NIST Handbook 44 tolerances for both tests. Permanence testing was expected to take place in approximately 30 days.

Upon learning that the device complied with applicable tolerances for both static and in-motion tests, the Sector agreed to recommend the requirement for 3/8 inch rail gaps specified in NCWM Publication 14, DES Section 70, “Inspect the Scale” 4. Rail Gaps (Page DES-115, 2013 Edition) be deleted and subsequent sections of NCWM Publication 14 renumbered.

Mr. Luthy was reminded by Mr. Harshman, NIST Technical Advisor, that in addition to NCWM Publication 14 needing to be changed, there were also requirements in NIST Handbook 44 that would likely need amending in order to support the use of continuous rails in the approaches and weighing areas of the scale. Mr. Harshman offered to assist Mr. Luthy in completing the forms necessary to propose changes to NIST Handbook 44 and cited General Code paragraph G-UR.2.1. Installation and Scales Code paragraph UR.2.4. Foundation, Supports, and Clearance as paragraphs possibly needing to be changed in order to allow for the use of continuous rails. Mr. Truex, NTEP Administrator, commented that NIST Handbook 44 would likely need to be changed before NTEP would issue a Certificate of Conformance (CC) for the device, noting that an NTEP evaluation is intended to verify conformance with NIST Handbook 44 requirements.

4. NCWM Publication 14 Load Cell Table 6 – Summary Table Examples

Source:

NTEP Administrator (2012 Weighing Sector Agenda Item 7)

Background/Discussion:

The NTEP Administrator was contacted by an individual questioning tolerance values for repeatability and creep shown in the example summary table in NCWM Publication 14 – Load Cells Table 6 “Example of a Summary Table for a Class III 3000 Single Load Cell” (the reported errors are shown in Table 6 in **shaded text**). The individual reported that:

1. The tolerance listed on the table should be the value from Table 3 - Tolerance for Class III Load Cells, page LC-10. That is, the repeatability error of a Class III 3000 single cell requirement (from Table 3) should be 0.7v (0-500v); 1.4v (501-2000v); 2.1v (2001-4000v); 3.5v (4001-10 000v), so the value of repeatability error shown on Table 6 should be other than 0.35v.
2. Similar error on Creep (time dependence) of Table 6, the value should follow the mpe Table T.N.4.6., the value of creep shown on Table 6 should be 1.05v other than 1.5v.
3. Same error on Creep change ($I_{20min} - I_{30min}$) of Table 6, according to Table T.N.4.6., it should be 0.1575v ($0.15 \times mpe$) other than 0.225v.

Table 6 – 2012 NTEP Publication 14 Load Cell Values (Page LC-17)

Summary Table (As requested in Item 12 of the load cell data format paper)				
		Critical Result⁴	Tolerance⁵	Result/Tolerance
a.	Load Cell Error	0.68 v	0.7 v	0.97
b.	Repeatability Error	0.19 v	0.35 v	0.55
c.	Temperature Effect on MDLO	0.57 v _{min} /5 °C	0.7 v _{min} /5 °C	0.82
d.	Creep (time dependence)	0.98 v	1.5 v	0.65
e.	Δ Creep = I _{20 min} – I _{30 min}	0.09 v	0.15 × mpe = style="background-color: yellow;">0.225 v	0.40
f.	Creep Recovery	0.17 v	0.5 v	0.34
g.	Effect of Barometric Pressure	0.185 v _{min} /kPa	1.0 v _{min} /kPa	0.15

Table 3.
Tolerance for Class III Load Cells

NIST Handbook 44 Reference	Single Cell Requirement		Multiple Cell Requirement	
Load Cell Error Table 6., Class III; T.N.3.2. and T.N.8.1.1.	0.7 Factor Applied		1.0 Factor Applied	
	Load	Tolerance	Load	Tolerance
	0 – 500 v	0.35v	0 – 500 v	0.50 v
	501 – 2000 v	0.70v	501 – 2000 v	1.00 v
	2001 – 4000 v	1.05v	2001 – 4000 v	1.50 v
	4001 – 10 000 v	1.75v	4001 – 10 000 v	2.50 v
Repeatability Error; T.N.5. and T.N.8.1.1.	0.7 Factor Applied		1.0 Factor Applied	
	Load	Tolerance	Load	Tolerance
	0 – 500 v	0.7 0 v	0 – 500 v	1.00 v
	501 – 2000 v	1.40 v	501 – 2000 v	2.00 v
	2001 – 4000 v	2.10 v	2001 – 4000 v	3.00 v
	4001 – 10 000 v	3.50 v	4001 – 10 000 v	5.00 v
Temperature Effect on Minimum Dead Load Output; T.N.8.1.3. and T.N.8.1.1.	0.7 v _{min} /5 °C		0.7 v _{min} /5 °C	
Effects of Barometric Pressure; T.N.8.2.	Applicable only to specified load cells 1 v _{min} /1 kPa		Applicable only to specified load cells 1 v _{min} /1 kPa	

During the 2012 WS Meeting, members voted unanimously in favor of approving the following corrections to Table 6 - 2012 NCWM Publication 14 Load Cell Values (Page LC-17):

Table 6 Corrected Version 2012 NCWM Publication 14 Load Cell Values (Page LC-17)

Summary Table (As requested in Item 12 of the load cell data format paper)				
		Critical Result ⁴	Tolerance ⁵	Result/Tolerance
a.	Load Cell Error	0.68 v	0.7 v	0.97
b.	Repeatability Error	0.19 v	0.35 v 0.7 v	0.55 0.27
c.	Temperature Effect on MDLO	0.57 v _{min} /5 °C	0.7 v _{min} /5 °C	0.82
d.	Creep (time dependence)	0.98 v	1.5 v 1.05 v	0.65 0.93
e.	Δ Creep = I _{20 min} – I _{30 min}	0.09 v	0.15 × mpe = 0.225 v 0.1575 v	0.40 0.57
f.	Creep Recovery	0.17 v	0.5 v	0.34
g.	Effect of Barometric Pressure	0.185 v _{min} /kPa	1.0 v _{min} /kPa	0.15

⁴The critical test result is the test result that gives the greatest ratio of result to tolerance. There may be other errors of greater absolute value but that give smaller ratios of result to tolerance.

⁵The tolerance is the value from the tolerance table of the NTEP procedure that corresponds to the critical test result.

There were three load cell manufacturer representatives present at the 2012 WS Meeting, who, for unknown reason, did not vote. Because those three represented the majority of the load cell manufacturers present at that meeting, it was decided that the Sector recommend to the 2012 NTEP Committee that the changes approved by the Sector be made to the table, but that the item also remain as a carry-over item on the 2013 WS agenda to allow for additional consideration of the changes.

The NTEP Committee accepted all proposed changes to the table and a corrected version of the table was added to 2013 NCWM Publication 14 Load Cells to replace the previous existing table. The following two summary tables, the lower of which reflects the changes recommended by the WS and approved by 2012 NTEP Committee, appear beneath the title “Table 6” on page LC-17 of 2013 NCWM Publication 14 Load Cells:

Table 6.
Example of a Summary Table for a Class III 3000 Single Load Cell

Summary Table (As requested in Item 12 of the load cell data format paper)			
	Critical Result ²	Tolerance ³	Result/Tolerance
Load Cell Error	0.68 v	0.7 v	0.97
Repeatability Error	0.19 v	0.35 v	0.55
Temperature Effect on MDLO	0.57 v _{min} /5 °C	0.7 v _{min} /5 °C	0.82
Creep (time dependence)	0.98 v	1.5 v	0.65
Effect of Barometric Pressure	0.185 v _{min} /kPa	1.0 v _{min} /kPa	0.15

Summary Table (As requested in Item 12 of the load cell data format paper)				
		Critical Result⁴	Tolerance⁵	Result/Tolerance
a.	Load Cell Error	0.68 v	0.7 v	0.97
b.	Repeatability Error	0.19 v	0.7 v	0.27
c.	Temperature Effect on MDLO	0.57 v _{min} /5 °C	0.7 v _{min} /5 °C	0.82
d.	Creep (time dependence)	0.98 v	1.05 v	0.93
e.	Δ Creep = I _{20 min} – I _{30 min}	0.09 v	0.15 x mpe = 0.1575 v	0.57
f.	Creep Recovery	0.17 v	0.5 v	0.34
g.	Effect of Barometric Pressure	0.185 v _{min} /kPa	1.0 v _{min} /kPa	0.15

²The critical test result is the test result that gives the greatest ratio of result to tolerance. There may be other errors of greater absolute value but that give smaller ratios of result to tolerance.

³The tolerance is the value from the tolerance table of the NTEP procedure that corresponds to the critical test result.

⁴The critical test result is the test result that gives the greatest ratio of result to tolerance. There may be other errors of greater absolute value but that give smaller ratios of result to tolerance.

⁵The tolerance is the value from the tolerance table of the NTEP procedure that corresponds to the critical test result.

For additional background information relative to this item and actions taken by the NTEP Weighing Sector during its 2012 meeting go to: <http://www.ncwm.net/meetings/ntep/weighing/archive>.

Conclusion:

The Sector agreed that the changes approved in 2012 to the values in the lower of the two tables beneath the heading “Table 6” are correct. In reviewing this item, it was pointed out that the values in the upper table were not changed to reflect the corrections that had been made to the values in the lower table and that the upper table also seemed redundant. After comparing the information included in the two tables, the Sector agreed, and consequently, recommended that the upper table be deleted and the footnotes in the lower table and all subsequent footnotes in NCWM Publication 14 Load Cells be renumbered. The following reflects the changes agreed to by the Sector at their 2013 meeting concerning this item:

Table 6.

Example of a Summary Table for a Class III 3000 Single Load Cell

Summary Table (As requested in Item 12 of the load cell data format paper)			
	Critical Result²	Tolerance³	Result/Tolerance
Load Cell Error	0.68 v	0.7 v	0.97
Repeatability Error	0.19 v	0.35 v	0.55
Temperature Effect on MDLO	0.57 v_{min}/5 °C	0.7 v_{min}/5 °C	0.82
Creep (time dependence)	0.98 v	1.5 v	0.65
Effect of Barometric Pressure	0.185 v_{min}/kPa	1.0 v_{min}/kPa	0.15

Summary Table (As requested in Item 12 of the load cell data format paper)				
		Critical Result ^{4,2}	Tolerance ^{5,3}	Result/Tolerance
a.	Load Cell Error	0.68 v	0.7 v	0.97
b.	Repeatability Error	0.19 v	0.7 v	0.27
c.	Temperature Effect on MDLO	0.57 v _{min} /5 °C	0.7 v _{min} /5 °C	0.82
d.	Creep (time dependence)	0.98 v	1.05 v	0.93
e.	Δ Creep = I _{20 min} – I _{30 min}	0.09 v	0.15 x mpe = 0.1575 v	0.57
f.	Creep Recovery	0.17 v	0.5 v	0.34
g.	Effect of Barometric Pressure	0.185 v _{min} /kPa	1.0 v _{min} /kPa	0.15

²The critical test result is the test result that gives the greatest ratio of result to tolerance. There may be other errors of greater absolute value but that give smaller ratios of result to tolerance.

³The tolerance is the value from the tolerance table of the NTEP procedure that corresponds to the critical test result.

~~⁴The critical test result is the test result that gives the greatest ratio of result to tolerance. There may be other errors of greater absolute value but that give smaller ratios of result to tolerance.~~

~~⁵The tolerance is the value from the tolerance table of the NTEP procedure that corresponds to the critical test result.~~

Renumber all subsequent footnotes in NCWM Publication 14 Load Cells.

NEW ITEMS

5. Item 360-7 NIST Handbook 44, Appendix D – Definitions: Remote Configuration Capability

Source

2013 NCWM S&T Committee (2012 Grain Analyzer Sector Meeting Summary)

Background/Discussion:

At the 2012 NTEP Grain Analyzer Sector meeting, the Sector agreed to forward a proposal to amend the definition of “remote configuration capability” in NIST Handbook 44 to the S&T Committee for consideration. The following changes were proposed:

remote configuration capability. – The ability to adjust a weighing or measuring device or change its sealable parameters from or through some other device that ~~is not~~ may or may not itself be necessary to the operation of the weighing or measuring device or ~~is not~~ may or may not be a permanent part of that device.[2.20, 2.21, 2.24, 3.30, 3.37, 5.56(a)]

(Added 1993) (~~Amended 20XX~~)

The Grain Analyzer Sector noted in their proposal that removable digital storage devices containing the latest grain calibrations can be used in grain moisture meters (GMMs) as either data transfer devices that are not necessary to the operation of the GMM or as data storage devices which are necessary to the operation of the GMM. If removable data storage devices are necessary to the operation of the device, they are not covered by the current definition of remote configuration capability.

A USB flash drive is most likely to be used as a data transfer device. In a typical data transfer application, the USB flash drive is first connected to a computer with access to the GMM manufacturer’s web site to download the latest grain calibrations that are then stored in the USB flash drive. The USB flash drive is removed from the computer and plugged into a USB port on the GMM. The GMM is put into remote configuration mode to copy the new grain

calibration data into the GMM's internal memory. When the GMM has been returned to normal operating (measuring) mode the USB flash drive can be removed from the GMM.

Although a Secure Digital (SD) memory card could also be used as a data transfer device it is more likely to be used as a data storage device. In a typical "data storage device" application, the SD memory card stores the grain calibrations used on the GMM. The SD memory card must be plugged into an SD memory card connector on a GMM circuit card for the GMM to operate in measuring mode. To install new grain calibrations the GMM must be turned "off" or put into a mode in which the SD memory card can be safely removed. The SD memory card can either be replaced with an SD memory card that has been programmed with the new grain calibrations or the original SD memory card can be re-programmed with the new grain calibrations in much the same way as that described in the preceding paragraph to copy new grain calibrations into a USB flash drive. In either case, the SD memory card containing the new calibrations must be installed in the GMM for the GMM to operate in measuring mode. In that regard, the SD memory card (although removable) can be considered a permanent part of the GMM in that the GMM cannot operate without it.

Note: In the above example, the SD memory card could be any removable flash memory card such as the Secure Digital Standard-Capacity, the Secure Digital High-Capacity, the Secure Digital Extended-Capacity, and the Secure Digital Input/Output, which combines input/output functions with data storage. These come in three form factors: the original size, the mini size, and the micro size. A Memory Stick is a removable flash memory card format, launched by Sony in 1998, and is also used in general to describe the whole family of Memory Sticks. In addition to the original Memory Stick, this family includes the Memory Stick PRO, the Memory Stick Duo, the Memory Stick PRO Duo, the Memory Stick Micro, and the Memory Stick PRO-HG.

During its Open Hearings at the 2013 NCWM Interim Meeting, the S&T Committee heard comments from Ms. Juanita Williams (NIST, OWM). OWM suggested the Committee consider this item as a Developing item to allow other Sectors to discuss how a change to the definition may affect other device types of similar design and to consider changes if needed. OWM recognizes that the current definition for "remote configuration capability" may not address those grain moisture meters (GMMs) which can only be operated with a removable data storage device, containing, among other things, the grain calibrations intended for use with the GMM, inserted in the device (as was described by the Grain Analyzer Sector). As such, OWM noted that current sealing requirements were developed at a time when such technology likely didn't exist, nor could be envisioned, and are based on the current definition of remote configuration capability. Because the current definition was never intended to apply to this "next generation" technology, OWM suggested that those charged with further development of this item may wish to revisit the five philosophies of sealing and consider whether a new paragraph, completely separate from current sealing requirements, might be appropriate and a better option, than the one currently proposed. The five philosophies of sealing are included in the 1992 *Report of the 77th National Conference on Weights and Measures* (Report of the Specifications and Tolerances Committee). Another option, preferred over the changes currently proposed, would be to add a separate statement to the current definition of "remote configuration capability" to address removable storage devices. For example, the following sentence might be considered as an addition to the current definition for "remote configuration capability:"

Devices which are programmed using removable media (such as SD cards, flash drives, etc.) that may or may not be required to remain with the device during normal operation are also considered to be remotely configured devices.

The Committee also heard comments from Mr. Dmitri Karimov (LC), speaking on behalf of the MMA, who made two points: (1) flow computers may already have these capabilities, thus it may be more appropriate to consider adding requirements to the General Code so that the requirements will be uniformly applied to all device types; and (2) the Committee should look ahead and consider other capabilities that may or already have emerged such as wireless communication and configuration.

The Committee acknowledged the comments indicating that the current definition of "remote configuration capability" was developed at a time when certain technologies, such as blue tooth, SD storage devices, flash drives, etc., didn't exist. The Committee recognized that it may be difficult to modify the existing definition and associated requirements to be flexible enough to address emerging and future technologies without having a significant (and possibly detrimental impact) on existing devices. Consequently, rather than modifying the current definition, the

Committee concluded that a better approach might be to develop an entirely separate set of security requirements that would apply to emerging technologies. The Committee believes that additional work is needed to develop proposed definition(s) and associated requirements and decided to designate the item as Developmental. The Committee requests other Sectors review the Grain Sector's proposed modification to the definition as well as OWM's suggestions and provide input.

During the 2013 NTEP Laboratory Meeting, the NTEP evaluators were asked if they were aware of or had observed during any of their evaluations of a weighing or measuring device, one which required some form of memory card or data storage device be installed in order for the device to be operational in the measuring or weighing mode. A weighing representative from Measurement Canada reported that he had observed scales having flash drives (some of which were micro in size) that are sealed via physical seal that contain calibration information and possibly even the operating system stored on a card, which must remain in the device in order for the device to be operational. The U.S. NTEP evaluators (i.e., on both the weighing and measuring side) reported they had no knowledge of such technology being used in devices they had evaluated, but they also acknowledged that it could have been present without them noticing it during the evaluation process.

At the 2013 NCWM Annual Meeting, OWM reiterated comments it made at the 2013 Interim Meeting suggesting that it may be appropriate to develop separate requirements to address new and future technologies which can be remotely configured with removable media. OWM indicated it plans to develop draft language and request input from the various sectors at their upcoming meetings. Two additional comments were made in support of possibly including requirements in the General Code of NIST Handbook 44 to address newer and emerging technologies.

See Final Report of the 2013 NCWM S&T Committee Agenda Item 356-3 for additional background information on this item to amend the definition for "remote configuration capability" in HB 44 Appendix D.

Conclusion:

At the 2013 WS meeting, OWM requested members of the Sector help identify the various types of removable storage media (e.g., USB flash drives, SD memory cards, etc.) currently in use with weighing equipment and to describe the functionality of that media. The information provided would likely be used by OWM to develop some draft proposals to amend NIST Handbook 44 to adequately address the security of the metrological significant parameters of devices using such media.

The following feedback was provided by members of the Sector to OWM:

- I am not in favor of changing standards for advances in technology.
- Both SD cards and USB Flash drives can be used for data transfer and data storage. It would be difficult to address all devices by changing the General Code.
- There are other technologies besides SD and Flash digital storage devices that must be considered (e.g., Eprom and EEPROM, etc).
- Several members commented that they felt it would likely be necessary to separate requirements in the various codes of NIST Handbook 44.
- It is not reasonable to expect manufacturers to share the technologies used in a public forum such as this meeting and it might be better to speak individually with representatives of the different manufacturers.

At the end of the discussion, a few Sector members offered to provide technical expertise to assist OWM in answering any questions that might arise during future development of proposed requirements to address this issue.

6. NCWM Publication 14 DES Section 76 Digital Controller Element for Load Cells Checklists and Test Procedures

Source:

NTEP Weighing Labs (2013 NTEP Lab Meeting)

Background/Discussion:

Section 76 Digital Controller Element for Load Cells Checklists and Test Procedures was first added to NCWM Publication 14 DES in 2013. During a review of the new checklists and test procedures at the April 2013 NTEP Lab Meeting, NTEP weighing evaluators questioned whether or not the nominal capacity, scale division d, value of e (if different than d), and CLC should be required marking on a Digital Controller Element that does not output a calibrated weight value as specified on page DES-134 of 2013 Publication 14 DES. The evaluators noted that values corresponding to such marking on a DCE would likely vary depending upon other components used to create the scale system, e.g., the weighing/load-receiving element, load cells, etc., in which a DCE is but one part. For this reason, the evaluators don't believe this information should necessarily be required on a DCE and requested that the NIST Technical Advisor include a new item on the 2013 WS agenda to determine if the WS shared their view.

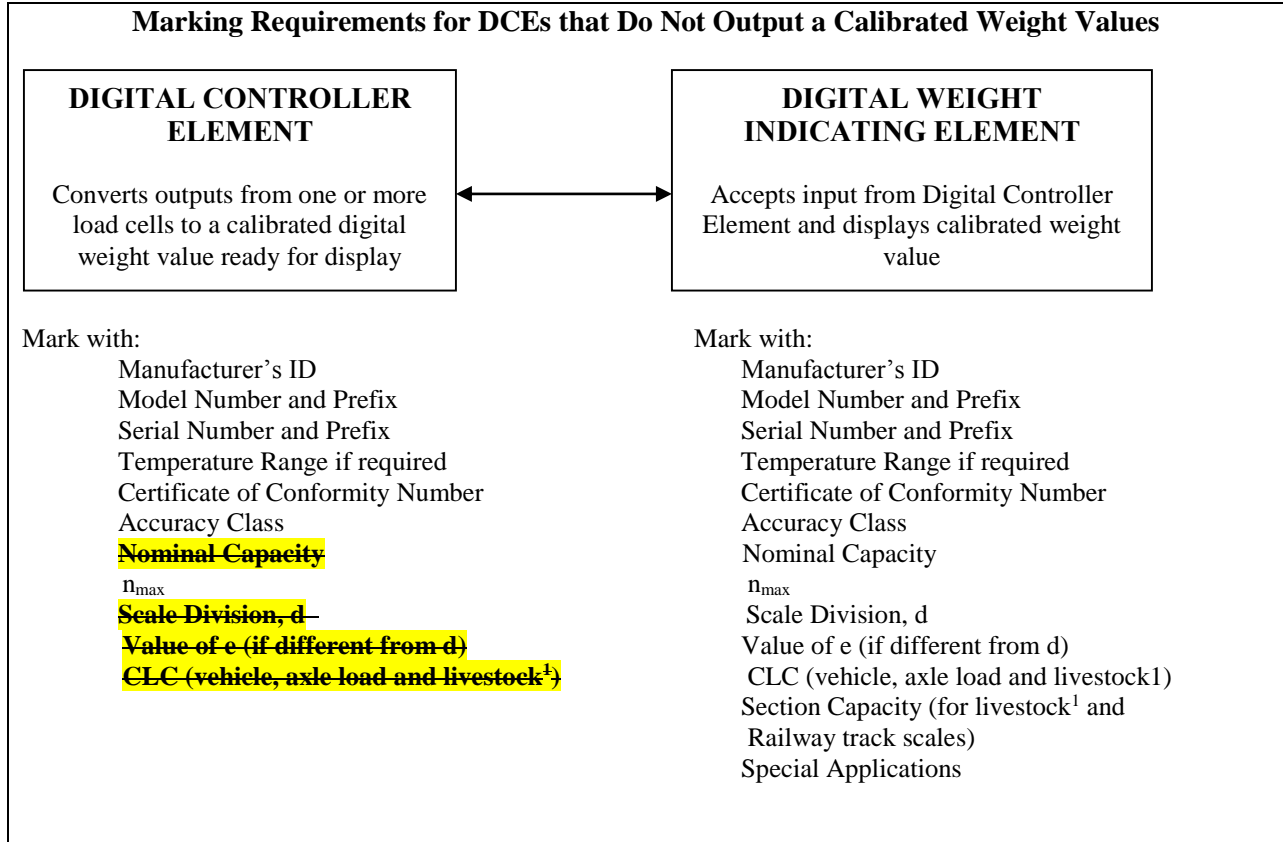

For additional background information relative to this item and actions taken by the NTEP Weighing Sector during its 2012 meeting go to: <http://www.ncwm.net/meetings/ntep/weighing/archive>.

Conclusion:

The Sector was asked to review the required marking information shown above for DCEs that do not output calibrated weight values, and determine whether or not the marking information ~~struck out~~ and shaded in the above illustration is needed.

In reviewing this item, one member of the Sector (a scale manufacturer representative) described a DCE as a scale indicator without a display, which led to a discussion regarding whether or not a DCE needed to be properly matched to other components of a scale system in order for the system to be considered suitable. If so, an additional column should be added to NIST Handbook 44 Scales Code Table S.6.3.a and include required marking information applicable to DCEs. The general consensus of the group was that required marking information for a DCE should not be added to Table S.6.3.a., although not everyone completely agreed. Consequently, the WS agreed to recommend that the information ~~struck out~~ and shaded in the illustration above be deleted.

7. NCWM Publication 14 DES Checklists and Test Procedures Section 1 Marking – Applicable to Indicating, Weighing/Load-Receiving Elements and Complete Scales

Source:

NTEP Labs (2013 NTEP Lab Meeting)

Background/Discussion:

A “Note” in Section 1 of the Checklists and Procedures of NCWM Publication 14 Digital Electronic Scales specifies that for consistency purposes the NTEP labs use an Eberhard Faber ink eraser type #110 to verify the permanence of the lettering used to mark required information on a device. It has been reported that this particular eraser may no longer be available in the marketplace. Consequently, the NTEP lab evaluators were recently asked to try and identify a suitable replacement for this eraser; but to date, no replacement has been identified.

Conclusion:

The WS was asked to help identify a suitable replacement for the Eberhard Faber ink eraser type #110, which could readily be procured by all the NTEP labs at a reasonable cost and enable the NTEP labs to continue testing the permanence of lettering used to mark required information on a device using the same testing medium.

A few Sector members suggested investigating the possibility of using an ink eraser called “Black Pearl” as a possible suitable replacement. It was also mentioned that there are clay bars used in the auto detailing industry that might prove satisfactory. Mr. Truex agreed to look into the possibility of replacing the current eraser with one of the products mentioned and to continue searching until a suitable replacement is found.

8. NCWM Publication 14 Load Cells - National Type Evaluation Program Terminology for Load Cell Parameters

Source: Mr. Steve Langford, Cardinal Scale (2013)

Background/Discussion: Mr. Steve Langford has discovered what he believes to be an editorial error in some of the text included in Figure 1. Illustration of Load Cell Parameters on page LC-19 of NCWM Publication 14 Load Cells. The illustration uses the term “Maximum Dead Load” in association with D_{max} to identify the upper extreme of the load cell measuring range. Mr. Langford believes the word “Dead” should be removed so that the term reads “Maximum Load.” This change would align the text with footnote 7 of the illustration, the definition of D_{max} in NIST Handbook 44, and OIML R60 Section 2.3.6.

The WS was asked to review NCWM Publication 14 Load Cells Figure 1. Illustration of Load Cell Parameters and determine whether or not the change suggested by Mr. Langford is appropriate and whether or not additional changes to any of the text included in Figure 1. are needed. Figure 1. Illustration of Load Cell Parameters has been copied from Publication 14 and pasted below with the change suggested by Mr. Langford shaded. Included for reference are definitions of “ D_{max} ” and “ D_{min} ,” which were copied from NIST Handbook 44 and Section 2.3.6., copied from OIML R 60.

Figure 1.
Illustration of Load Cell Parameters

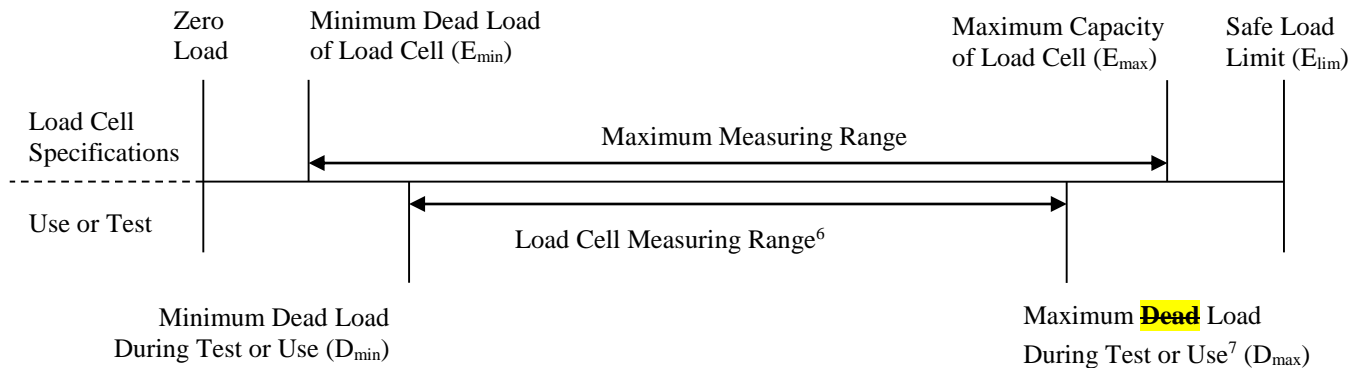

⁶The limiting conditions for the measuring range for use or test are the minimum dead load and maximum capacity of the load cell.

⁷Maximum load for National Type Evaluation Program test must be at least 90% of the maximum capacity of the load cell, National Institute of Standards and Technology will not go beyond the maximum capacity of the load cell. If the manufacturer test equipment limits the loads that may be applied, the manufacturer may test to a load in excess of the maximum capacity of the load cell.

Appendix D – Definitions NIST Handbook 44:

D_{max} (maximum load of the measuring range). – Largest value of a quantity (mass) which is applied to a load cell during test or use. This value shall not be greater than E_{max} . [2.20]
 (Added 2005)

D_{min} (minimum load of the measuring range). – Smallest value of a quantity (mass) which is applied to a load cell during test or use. This value shall not be less than E_{min} . [2.20]
 (Added 2006)

OIML R 60 Metrological Regulation for Load Cells:

2.3.6 Maximum load of the measuring range (D_{max}) Largest value of a quantity (mass) which is applied to a load cell during test or use. This value shall not be greater than E_{max} (see 2.3.5). For the limits on D_{max} during testing, see A.3.2.4.

Conclusion:

The Sector agreed with Mr. Langford’s assertion that the word “Dead” should not appear in association with D_{max} and recommends that the word be removed from the illustration as suggested.

9. Identification of Certified Software

Source: NTEP Software Sector (2013 Software Sector Meeting)

Background/Discussion: This item originated as an attempt to answer the question “How does the field inspector know that the software running in the device is the same software evaluated and approved by the lab?” In previous meetings it was shown that the international community has addressed this issue (both WELMEC and OIML).

At the 2012 NTEP Software Sector Meeting, there was some discussion as to where the terminology regarding inextricably linking the software version or revision to the software itself belonged. The Software Sector

recommended adding the following to NCWM Publication 14 and forward to NTEP Weighing, Measuring, and Grain Analyzer Sectors for feedback:

Identification of Certified Software:

Note: Manufacturers may choose to separate metrologically significant software from non-metrologically significant software. Separation would allow the revision of the non-metrological portion without the need for further evaluation. In addition, non-metrologically significant software may be updated on devices without breaking a seal, if so designed. Separation of software requires that all software modules (programs, subroutines, objects, etc.) that perform metrologically significant functions or that contain metrologically significant data domains form the metrologically significant software part of a measuring instrument (device or sub-assembly). If the separation of the software is not possible or needed, then the software is metrologically significant as a whole. The conformity requirement applies to all parts and parts shall be marked according to Section G-S-X.X.

The manufacturer must describe and possibly demonstrate how the version or revision identifier is directly and inseparably linked to the metrologically significant software. Where the version revision identifier is comprised of more than one part, the manufacturer shall describe which portion represents the metrological significant software and which does not.

Conclusion:

Members of the Weighing Sector reviewed the two paragraphs shown above for which the Software Sector requested feedback and after agreeing that the last sentence of the first paragraph should be deleted, agreed to recommend that both paragraphs (minus the last sentence of the first paragraph) be added to the following Sections of NCWM Publication 14:

- DES Section 3;
- ECRS Section 5.11;
- ABWS Section 17.5.; and
- AWS Section 1.2.

The following text, less the ~~struck-out~~ sentence shown, is recommended by the Sector for insertion into the Sections of Publication 14 identified above:

Identification of Certified Software:

Note: Manufacturers may choose to separate metrologically significant software from non-metrologically significant software. Separation would allow the revision of the non-metrological portion without the need for further evaluation. In addition, non-metrologically significant software may be updated on devices without breaking a seal, if so designed. Separation of software requires that all software modules (programs, subroutines, objects, etc.) that perform metrologically significant functions or that contain metrologically significant data domains form the metrologically significant software part of a measuring instrument (device or sub-assembly). If the separation of the software is not possible or needed, then the software is metrologically significant as a whole. The conformity requirement applies to all parts and parts shall be marked according to Section G-S-X.X.

The manufacturer must describe and possibly demonstrate how the version or revision identifier is directly and inseparably linked to the metrologically significant software. Where the version revision identifier is comprised of more than one part, the manufacturer shall describe which portion represents the metrological significant software and which does not.

10. Software Protection/Security

Source:

NTEP Software Sector (2013 Software Sector Meeting)

Background

The NTEP Software Sector agreed that NIST Handbook 44 already has audit trail and physical seal, but these may need to be enhanced.

From the WELMEC Document:

Protection against accidental or unintentional changes

Metrologically significant software and measurement data shall be protected against accidental or unintentional changes.

Specifying Notes:

Possible reasons for accidental changes and faults are: unpredictable physical influences, effects caused by user functions and residual defects of the software even though state of the art of development techniques have been applied.

This requirement includes consideration of:

- a) Physical influences: Stored measurement data shall be protected against corruption or deletion when a fault occurs or, alternatively, the fault shall be detectable.
- b) User functions: Confirmation shall be demanded before deleting or changing data.
- c) Software defects: Appropriate measures shall be taken to protect data from unintentional changes that could occur through incorrect program design or programming errors, e.g. plausibility checks.

Required Documentation:

The documentation should show the measures that have been taken to protect the software and data against unintentional changes.

Example of an Acceptable Solution:

- The accidental modification of software and measurement data may be checked by calculating a checksum over the relevant parts, comparing it with the nominal value and stopping if anything has been modified.
- Measurement data are not deleted without prior authorization, e.g. a dialogue statement or window asking for confirmation of deletion.
- For fault detection see also Extension I.

The Software Sector continued to develop a proposed checklist for NCWM Publication 14. The numbering will still need to be added. This is based roughly on R 76-2 checklist and discussions beginning as early as the October 2007 NTEP Software Sector Meeting. The information requested by this checklist is currently voluntary, however, it is recommended that applicants comply with these requests or provide specific information as to why they may not be able to comply. Based on this information, the checklist may be amended to better fit with NTEP's need for information and the applicant's ability to comply.

The California, Maryland, and Ohio laboratories agreed to use this check list on one of the next devices they have in the lab and report back to the Sector on what the problems may be. In February 2011, the North Carolina laboratory was also given a copy of the check list to try.

1. Devices with Embedded Software TYPE P (aka built-for-purpose)		
1.1. Declaration of the manufacturer that the software is used in a fixed hardware and software environment. AND	<input type="checkbox"/>	Yes <input type="checkbox"/> No <input type="checkbox"/> N/A
1.2. Cannot be modified or uploaded by any means after securing/verification. <i>Note: It is acceptable to break the "seal" and load new software, audit trail is also a sufficient seal.</i>	<input type="checkbox"/>	Yes <input type="checkbox"/> No <input type="checkbox"/> N/A
1.3. The software documentation contains:		
1.3.1. Description of all functions, designating those that are considered metrologically significant.	<input type="checkbox"/>	Yes <input type="checkbox"/> No <input type="checkbox"/> N/A
1.3.2. Description of the securing means (evidence of an intervention).	<input type="checkbox"/>	Yes <input type="checkbox"/> No <input type="checkbox"/> N/A
1.3.3. Software Identification, including version/revision	<input type="checkbox"/>	Yes <input type="checkbox"/> No <input type="checkbox"/> N/A
1.3.4. Description how to check the actual software identification.	<input type="checkbox"/>	Yes <input type="checkbox"/> No <input type="checkbox"/> N/A
1.4. The software identification is:		
1.4.1. Clearly assigned to the metrologically significant software and functions.	<input type="checkbox"/>	Yes <input type="checkbox"/> No <input type="checkbox"/> N/A
1.4.2. Description how to check the actual software identification.	<input type="checkbox"/>	Yes <input type="checkbox"/> No <input type="checkbox"/> N/A
1.4.3. Provided by the device as documented.	<input type="checkbox"/>	Yes <input type="checkbox"/> No <input type="checkbox"/> N/A
1.4.4. Directly linked to the software itself.	<input checked="" type="checkbox"/>	Yes <input type="checkbox"/> No <input type="checkbox"/> N/A
2. Personal Computers, Instruments with PC Components, and Other Instruments, Devices, Modules, and Elements with Programmable or Loadable Metrologically Significant Software TYPE U (aka not built-for-purpose)		
2.1. The metrologically significant software is:		
2.1.1. Documented with all relevant information (see below for list of documents).	<input type="checkbox"/>	Yes <input type="checkbox"/> No <input type="checkbox"/> N/A
2.1.2. Protected against accidental or intentional changes.	<input type="checkbox"/>	Yes <input type="checkbox"/> No <input type="checkbox"/> N/A
2.2. Evidence of intervention (such as, changes, uploads, circumvention) is available until the next verification/inspection (e.g., physical seal, Checksum, Cyclical Redundancy Check (CRC), audit trail, etc. means of security).	<input type="checkbox"/>	Yes <input type="checkbox"/> No <input type="checkbox"/> N/A
3. Software with Closed Shell (no access to the operating system and/or programs possible for the user)		
3.1. Check whether there is a complete set of commands (e.g., function keys or commands via external interfaces) supplied and accompanied by short descriptions.	<input type="checkbox"/>	Yes <input type="checkbox"/> No <input type="checkbox"/> N/A
3.2. Check whether the manufacturer has submitted a written declaration of the completeness of the set of commands.	<input type="checkbox"/>	Yes <input type="checkbox"/> No <input type="checkbox"/> N/A
4. Operating System and/or Program(s) Accessible for the User		
4.1. Check whether a checksum or equivalent signature is generated over the machine code of the metrologically significant software (program module(s) subject to legal control Weights and Measures jurisdiction and type-specific parameters).	<input type="checkbox"/>	Yes <input type="checkbox"/> No <input type="checkbox"/> N/A
4.2. Check whether the metrologically significant software will detect and act upon any unauthorized alteration of the metrologically significant software using	<input type="checkbox"/>	Yes <input type="checkbox"/> No <input type="checkbox"/> N/A

simple software tools (e.g., text editor).

5. Software Interface(s)

5.1. Verify the manufacturer has documented:

- | | |
|-----------------------------------------------------------------------------------------------------------------------------|--------------------------------------------------------------------------------------------------|
| 5.1.1. The program modules of the metrologically significant software are defined and separated. | <input type="checkbox"/> Yes <input type="checkbox"/> No <input type="checkbox"/> N/A |
| 5.1.2. The protective software interface itself is part of the metrologically significant software. | <input checked="" type="checkbox"/> Yes <input type="checkbox"/> No <input type="checkbox"/> N/A |
| 5.1.3. The functions of the metrologically significant software that can be accessed via the protective software interface. | <input type="checkbox"/> Yes <input type="checkbox"/> No <input type="checkbox"/> N/A |
| 5.1.4. The parameters that may be exchanged via the protective software interface are defined. | <input type="checkbox"/> Yes <input type="checkbox"/> No <input type="checkbox"/> N/A |
| 5.1.5. The description of the functions and parameters are conclusive and complete. | <input type="checkbox"/> Yes <input type="checkbox"/> No <input type="checkbox"/> N/A |
| 5.1.6. There are software interface instructions for the third party (external) application programmer. | <input type="checkbox"/> Yes <input type="checkbox"/> No <input type="checkbox"/> N/A |

The Maryland laboratory had particular questions regarding 3.1 and 5.1. The information for 3.1. could be acquired from an operator’s manual, a training video, or in-person training. The items in 5.1. were confusing to the evaluators. The terminology is familiar to software developers, but not necessarily others. It was indicated that manufacturers were typically quick to return the filled out questionnaire, but he didn’t know how his laboratory was supposed to verify that it was true. Generally, the laboratories wouldn’t be expected to verify things to that level. For example, if the manufacturer states that a checksum is used to ensure integrity, the laboratories wouldn’t be expected to evaluate the algorithm used.

The intent was to see whether the manufacturer had at least considered these issues, not for evaluators to become software engineers. Perhaps a glossary or descriptive paragraphs might be added to assist the evaluators if the manufacturer has questions for the evaluators.

OIML makes use of supplementary documents to explain the checklist they use. Below are links:

- <http://www.oiml.org/publications/D/D031-e08.pdf>
- <http://www.welmec.org/latest/guides/72.html>
- http://www.welmec.org/fileadmin/user_files/publications/2-3.pdf

WELMEC document 2.3 is the original source for our checklist, but it’s been significantly revised and simplified. Mr. Payne, Maryland Department of Agriculture, is going to review the other documents and come up with some suggestions for the checklist. Mr. Roach, California Division of Measurement Standards, is going to begin using the checklist. The international viewpoint is that any device running an operating system is considered to be Type U. Mr. Roach mentioned that they’re having lots of problems with “skimmers” stealing PIN’s. Is there some way they can detect this?

Mr. Lewis, Rice Lake Weighing Systems, Inc., mentioned that he liked Measurement Canada’s website. When answering similar questions, different pages would appear, based on answers to those questions: <http://www.ic.gc.ca/eic/site/mc-mc.nsf/eng/lm00573.html>.

At the 2011 NTEP Software Sector Meeting, the laboratories were polled to obtain any feedback on the use of the checklist. Maryland attempted to use this checklist a few times. They had some difficulty obtaining answers from the manufacturers because the individual(s) interacting with the Maryland evaluator didn’t always have the required information on hand. More experience in using the checklist will help determine what needs to be revised.

It was suggested that the checklist could be sent to manufacturers for their feedback as well, with the stipulation that it be a completely voluntary exercise and purely informational at this point. The laboratories will coordinate with willing manufacturers to obtain feedback.

Work is ongoing on this item with the intent that it eventually will be incorporated as a checklist in NCWM Publication 14; again, the laboratories are requested to try utilizing this checklist for any evaluations on software-based electronic devices.

The checklist has been reviewed with an eye to making its terminology clearer to laboratories. Some examples and clarifications have been added as shown in the discussion section of this item. The revised checklist will be distributed to the laboratories for additional review. Maryland and California laboratories agreed to use the checklist on a trial basis.

Discussion:

Over the past year, attempts to use the current checklist did not meet with many difficulties. The checklists were given to the manufacturers to fill out, and that seemed to work rather well. Minor modifications (in red above) were made to clarify certain confusing areas or eliminate redundancy.

Conclusion:

The WS was asked to consider whether or not it is appropriate to add the proposed software checklist to NCWM Publication 14, and if so, to identify which of the checklists within Publication 14 Weighing Devices it is be included, e.g., DES, AWS, etc.

Feedback to the Software Sector. The WS reviewed the checklist and is opposed to adding it to any of the Weighing Device checklists within NCWM Publication 14 for the following reasons:

- nonretroactive application: that is, a concern was raised concerning applying the checklist to existing equipment with software.
- metrological and nonmetrological software issue: that is, Subsection 1.2. of the checklist implies that you cannot load any software without breaking a seal.
- The checklist is not supported by NIST *Handbook 44*.
- The meaning of some terms included in the checklist is not clear (e.g., “fixed hardware,” “software environment”).

11. Software Maintenance and Reconfiguration

Source:

NTEP Software Sector (2013 Software Sector Meeting)

Background

After the software is completed, what do the manufacturers use to secure their software? The following items were reviewed by the NTEP Software Sector. *Note that Agenda Item 3 also contains information on Verified and Traced updates and Software Log.*

1. Verify that the update process is documented. (OK)
2. For traced updates, installed Software is authenticated and checked for integrity.

Technical means shall be employed to guarantee the authenticity of the loaded software (i.e., that it originates from the owner of the type approval certificate). This can be accomplished (e.g., by cryptographic means like signing). The signature is checked during loading. If the loaded software fails this test, the instrument shall discard it and either use the previous version of the software **or become inoperative.**

Technical means shall be employed to guarantee the integrity of the loaded software (i.e., that it has not been inadmissibly changed before loading). This can be accomplished, for example, by adding a checksum or hash code of the loaded software and verifying it during the loading procedure. If the loaded software fails this test, the instrument shall discard it and either use the previous version of the software **or become inoperative.**

Examples are not limiting or exclusive.

3. Verify that the sealing requirements are met.
The Software Sector asked “What sealing requirements are we talking about?”

This item is **only** addressing the **software update**. It can be either verified or traced. It is possible that there are two different security means, one for protecting software updates (software log) and one for protecting the other metrological parameters (Category I, II, or III method of sealing). Some examples provided by the Sector members include but are not limited to:

Physical Seal, software log
Category III method of sealing can contain both means of security

4. Verify that if the upgrade process fails, the device is inoperable or the original software is restored.

The question before the group is, can this be made mandatory?

The manufacturer shall ensure by appropriate technical means (e.g. an audit trail) that traced updates of metrologically significant software are adequately traceable within the instrument for subsequent verification and surveillance or inspection. This requirement enables inspection authorities, which are responsible for the metrological surveillance of legally controlled instruments, to back-trace traced updates of metrologically significant software over an adequate period of time (that depends on national legislation). The statement in *italics* will need to be reworded to comply with U.S. weights and measures requirements.

The Software Sector **agreed** that the two definitions below for Verified Update and Traced Update were acceptable.

Verified Update

A verified update is the process of installing new software where the security is broken and the device must be re-verified. Checking for authenticity and integrity is the responsibility of the owner/user.

Traced Update

A traced update is the process of installing new software where the software is automatically checked for authenticity and integrity, and the update is recorded in a software update log or audit trail.

Note: It's possible that the Philosophy of Sealing section of NCWM Publication 14 may already address the above IF the definitions of Verified and Traced Updates (and the statement below) were to be added. The contrary argument was that it may be better to be explicit.

Use of a Category 3 audit trail is required for a Traced Update. A log entry representing a traced software update shall include the software identification of the newly installed version.

The Sector recommended consolidating the definitions with the above statement thus:

Verified Update

A verified update is the process of installing new software where the security is broken and the device must be re-verified. Checking for authenticity and integrity is the responsibility of the owner/user.

Traced Update

A traced update is the process of installing new software where the software is automatically checked for authenticity and integrity, and the update is recorded in a ~~software update log or~~ Category 3 audit trail. The audit trail entry shall include the software identification of the newly installed version.

In 2012, the Sector recommended that as a first step, the following be added to NCWM Publication 14:

The updating of metrologically significant software, including software that checks the authenticity and integrity of the updates, shall be considered a sealable event.

Mr. Truex, NTEP Administrator, indicated that, in his opinion, the above sentence is unnecessary since it's self-evident. It was agreed by the group however to ask the other sectors for feedback on the value of this addition.

Though the Software Sector is currently considering only the single sentence be incorporated into NCWM Publication 14 for the time being, ultimately, the Sector may wish to advance the remaining language of the original item submission.

Discussion:

The Software Sector had no information indicating that the other Sectors had yet been approached for feedback on the value of the addition of the proposed sentence.

Recommendation:

The Software Sector is requesting each of the NTEP Sectors review and provide feedback on the following draft language it developed for consideration of adding it to NCWM Publication 14:

The updating of metrologically significant software, including software that checks the authenticity and integrity of the updates, shall be considered a sealable event.

The Software Sector is also requesting feedback from the NTEP Sectors regarding whether or not additional language is needed in NCWM Publication 14 to make clear that an existing audit trail should be protected during a software update. In the background information provided for this item, it was noted that the Software Sector noted that this does already seem to be addressed in the Requirements for Metrological Audit Trails in Publication 14.

NIST Technical Advisor's note: NCWM Publication 14 DES Appendix B item 5 b. on page DES – 156 of General Requirements for Metrological Audit Trails addresses the protection of audit trail data as follows and may be why the Software Sector has indicated that this issue already seems to be addressed in NCWM Publication 14:

5.1.6.1. The audit trail data shall be:

- a. Stored in non-volatile memory and shall be retained for at least 30 days if power is removed from the device. **AND**
- b. Protected from unauthorized erasure, substitution, or modification.

This same provision also appears in Publication 14 AWS Appendix B.

Conclusion: The WS is opposed to adding the proposed sentence into NCWM Publication 14 at this time for the following reasons:

- If this statement were added into Publication 14, it would change the existing sealing requirements for devices with category 1, 2, and 3 methods of sealing. Category 1, 2, and 3 sealing does not currently require identification of software changes to event counters or event loggers. This would require a change to NIST Handbook 44.
- It's not clear that the requirement for authenticity and integrity of the updates is limited to only metrological significant software.

The WS currently believes that Publication 14 is not clear on whether or not an existing audit trail should be protected during a software update. This issue will need to be addressed as software requirements are added to NIST Handbook 44.

ATTACHMENTS

2014 Weighing Sector Meeting: NTEP Weighing Sector / August 26-27, 2014 / Site TBD [CA, Chicago, Atlanta, Denver]

THIS PAGE INTENTIONALLY LEFT BLANK

Sub-Appendix A

National Conference on Weights and Measures / National Type Evaluation Program

Weighing Sector Attendee List Final August 27-28, 2013 / Albany, NY



Steven Beitzel

Systems Associates
1932 Industrial Drive
Libertyville, IL 60048
P. (847) 367-6650
E. sjbeitzel@systemassoc.com

Luciano Burtini

Measurement Canada
2008 Matera Avenue
Kelowna, BC V1V1W9
P. (250) 862-6557
E. luciano.burtini@ic.gc.ca

Scott Davidson

Mettler-Toledo, LLC
1150 Dearborn Drive
Worthington, OH 43085
P. (614) 438-4387
E. scott.davidson@mt.com

Darrell Flocken

Mettler-Toledo, LLC
1150 Dearborn Drive
Worthington, OH 43085
P. (614) 438-4393
E. darrell.flocken@mt.com

Rick Harshman

NIST, Weights and Measures Division
100 Bureau Drive, Stop 2600
Gaithersburg, MD 20899-2600
P. (301) 975-8107
E. richard.harshman@nist.gov

Jon Heinlein

Transcell Technology, Inc.
975 East Deerfield Parkway
Buffalo Grove, IL 60089
P. (847) 419-9180
E. jheinlein@transcell.com

Scott Henry

Motorola Solutions, Inc.
1700 Belle Meade Court
Lawrenceville, GA 30043
P. (770) 338-3884
E. scott.henry@motorolasolutions.com

Ken Jones

California Division of Measurement Standards
6790 Florin Perkins Road Suite 100
Sacramento, CA 95828
P. (916) 229-3052
E. kjones@cdfa.ca.gov

Thomas Jones

Hobart Corporation
401 West Market Street
Troy, OH 45374
P. (937) 332-2427
E. thomas.jones@hobartcorp.com

Stephen Langford

Cardinal Scale Manufacturing Co.
203 East Daugherty Street
Webb City, MO 64870
P. (417) 673-4631
E. slangford@cardet.com

NTEP Committee 2014 Final Report
Appendix F – 2013 Weighing Sector Summary
Sub-Appendix A – Weighing Sector Attendees

Paul A. Lewis, Sr.

Rice Lake Weighing Systems, Inc.
230 West Coleman Street
Rice Lake, WI 54868-2404
P. (715) 234-9171 ext.5322
E. plewis@ricelake.com

Ed Luthy

Schenck Process
108 Wade Drive
Dover, OH 44622
P. (440) 241-0194
E. e.luthy@schcnckprocess.com

Eric Morabito

New York State Weights and Measures
10 B Airline Drive
Albany, NY 12235
P. (518) 457-3452
E. Eric.Morabito@agriculture.ny.gov

Joe Morrison

Ohio Department of Agriculture
Weights and Measures
8995 East Main Street, Building 5
Reynoldsburg, OH 43068
P. (614) 728-6290
E. jmorrison@agri.ohio.gov

Edward Payne

Maryland Department of Agriculture
50 Harry S. Truman Parkway
Annapolis, MD 21401
P. (410) 841-5790
E. edward.payne@maryland.gov

Wayne Pugh

OCS Checkweighers, Inc.
2350 Hewatt Road
Snellville, GA 30039
P. (678) 232-0745
E. wayne.pugh@ocs-cw.com

Louis Straub

Fairbanks Scales, Inc.
3056 Irwin Drive S.E.
Southport, NC 28461
P. (910) 253-3250
E. lstraub@fairbanks.com

James Truex

National Conference on Weights and Measures
88 Carryback Drive
Pataskala, OH 43062
P. (740) 919-4350
E. jim.truex@ncwm.net

Tim Tyson

Kansas Department of Agriculture
Weights and Measures Division
PO Box 19282
Topeka, KS 66619
P. (785) 862-2415
E. tim.tyson@kda.ks.gov

Robert Upright Jr.

Vishay Transducers
42 Countryside Road
North Grafton, MA 01536
P. (508) 615-1185
E. rob.upright@vishaypg.com

Report of the Nominating Committee

Mr. Stephen Benjamin, Committee Chair
North Carolina

800 INTRODUCTION

The Nominating Committee (hereinafter referred to as the “Committee”) met during the 99th National Conference on Weights and Measures (NCWM) Interim Meeting, January 19 - 22, 2014, in Albuquerque, New Mexico. At that time, the Committee nominated persons for the various available Board of Director positions for the 100th NCWM. The following report reflects the decisions of the NCWM membership.

Table A identifies the agenda items by reference key, title of item, page number and the appendices by appendix designations, and Table B reflects the Voting Results.

**Table A
Table of Contents**

Reference Key	Title of Item	NOM Page
800	INTRODUCTION	1
810	NOMINATIONS.....	3
810-1	V Officer Nominations	3

**Table B
Voting Results**

<i>Reference Key Number</i>	<i>House of State Representatives</i>		<i>House of Delegates</i>		<i>Results</i>
	<i>Yeas</i>	<i>Nays</i>	<i>Yeas</i>	<i>Nays</i>	
To Elect the Slate of Officers as presented in the Report	Voice Vote				Adopted

THIS PAGE INTENTIONALLY LEFT BLANK

Details of All Items
(In order by Reference Key)

810 NOMINATIONS

(This item was adopted by unanimous vote of the 99th National Conference on Weights and Measures)

810-1 V Officer Nominations

Source:

Nominating Committee

Purpose:

Election of NCWM officers

Item Under Consideration:

The following slate of officers was selected by unanimous vote of the committee:

Chairman-Elect:

Mr. Jerry Buendel, Washington State Weights and Measures

Board of Directors Active Director – Western: (2 years)

Mr. Brett Gurney, Utah Weights and Measures

Board of Directors Active Director – Northeastern: (5 years)

Mr. Jimmy Cassidy, City of Cambridge, Massachusetts Weights and Measures

Treasurer: (1 year)

Mr. Mark Coyne, Brockton, Massachusetts Weights and Measures

Background/Discussion:

The Nominating Committee met during the 2014 Interim Meeting at the Hotel Albuquerque in Albuquerque, New Mexico at which time the Committee nominated the persons listed above to be officers of the 100th National Conference on Weights and Measures. In the selection of nominees from the active and associate membership, consideration was given to professional experience, qualifications of individuals, conference attendance and participation, and other factors considered to be important.

Mr. Stephen Benjamin, North Carolina | Committee Chair
Mr. Charles Carroll, Massachusetts | Member
Mr. Tim Chesser, Arkansas | Member
Ms. Angela Godwin, Ventura County, California | Member
Mr. Joe Gomez, New Mexico | Member
Mr. Frank Greene, Connecticut, Florida | Member
Mr. Tim Tyson, Kansas | Member

Nominating Committee

THIS PAGE INTENTIONALLY LEFT BLANK

99th Annual Meeting Attendees

Sprague Ackley

Intermec
6001 36th Avenue, W
Everett, WA 98203
Phone: (425) 501-8995
E-mail: hsackley@cs.com

Cary Ainsworth

USDA, GIPSA
75 Spring Street, Ste 230
Atlanta, GA 30303-3309
Phone: (404) 562-5426
E-mail: l.cary.ainsworth@usda.gov

John Albert

Missouri Department of Agriculture
1616 Missouri Boulevard
P.O. Box 630
Jefferson City, MO 65102
Phone: (573) 751-7062
E-mail: john.albert@mda.mo.gov

Mahesh Albuquerque

CDLE-Oil & Public Safety
633 17th Street
Ste 500
Denver, CO 80202
Phone: (303) 318-8502
E-mail: mahesh.albuquerque@state.co.us

Ross Andersen

25 Moon Drive
Albany, NY 12205
Phone: (518) 869-7334
E-mail: rjandersen12@gmail.com

Paige Anderson

National Association of Convenience Stores
1600 Duke Street
Alexandria, VA 22314
Phone: (703) 518-4221
E-mail: panderson@nacsonline.com

Cheryl Ayer

New Hampshire Department of Agriculture Markets
& Food
PO Box 2042
Concord, NH 03302
Phone: (603) 568-3387
E-mail: cheryl.ayer@agr.nh.gov

James Barnes

Michigan Department of Agriculture
940 Venture Lane
Williamston, MI 48895
Phone: 517-655-8202
E-mail: barnesj10@michigan.gov

Brett Barry

Clean Energy
4675 MacArthur Court, Ste 800
Newport Beach, CA 92660
Phone: (562) 522-7427
E-mail: bbarry@cleanenergyfuels.com

Joshua Bates

Union Pacific Railroad
1400 Douglas Street
Omaha, NE 68179
Phone: (402) 544-9099
E-mail: jcbates@up.com

Steve Becker

Schenck Pross
Whitewater, WI
Phone:
E-mail:

Steve Beitzel

Systems Associates, Inc.
1932 Industrial Drive
Libertyville, IL 60048
Phone: (847) 367-6650
E-mail: sjbeitzel@systemsassoc.com

Sam Bell

Echols Oil Company, Inc.
P.O. Box 1477
Greenville, SC 29602
Phone: (864) 233-6205
E-mail: info@scpma.com

Stephen Benjamin

North Carolina Department of Agriculture &
Consumer Services
1050 Mail Service Center
Raleigh, NC 27699-1050
Phone: (919) 707-3225
E-mail: steve.benjamin@ncagr.gov

Ann Boeckman

Kraft Food Group, Inc.
Three Lakes Drive
Northfield, IL 60093
Phone: (847) 646-2862
E-mail: ann.boeckman@kraftfoods.com

Matt Boes

Marathon Petroleum LP
539 S Main Street
Findlay, OH 45840
Phone: (419) 421-2243
E-mail: mdboes@marathonpetroleum.com

Ethan Bogren

Westchester County New York
40 Lake Street
North Salem, NY 10560
Phone: (914) 261-2268
E-mail: erok_24@yahoo.com

Ted Bohn

Argonne National Lab
9700 S Cass Avenue
Bldg 362-8225
Lement, IL 60439
Phone: (630) 816-7382
E-mail: tbohn@anl.gov

David Boykin

NCR Corporation
200 Highway 74 South
Peachtree City, GA 30269
Phone: (770) 288-1556
E-mail: boykin@ncr.com

Tim Broemmer

Avery Weigh-Tronix
272 Botanical Ridge Dr
Wentzville, MO 63385
Phone: (913) 617-9176
E-mail: tbroemmer@awtxglobal.com

James Brown

Michigan Department of Agriculture
940 Venture Lane
Williamston, MI 48895-2451
Phone: (517) 655-8202
E-mail: brownj11@michigan.gov

Rex Brown

Petroleum Equipment Institute
PO Box 2380
Tulsa, OK 74101
Phone: (918) 236-3961
E-mail: jrbrown@pei.org

Norm Brucker

Precision Measurement Standards, Inc.
1665 Bonaire Path West
Rosemount, MN 55068
Phone: (651) 423-3241
E-mail: sharnoma@frontiernet.net

Jim Buck

Oklahoma Dept. of labor
3017 N Stiles, Ste 100
Oklahoma City, OK 73105
Phone: (405) 521-6111
E-mail: james.buck@labor.ok.gov

Jerry Buendel

Washington State Department of Agriculture
1111 Washington Street
P.O. Box 42560
Olympia, WA 98504-2560
Phone: (360) 902-1856
E-mail: jbuendel@agr.wa.gov

Luciano Burtini

Measurement Canada
2008 Matera Avenue
Kelowna, BC V1V 1W9
Phone: (250) 862-6557
E-mail: luciano.burtini@ic.gc.ca

Tina Butcher

NIST, Office of Weights & Measures
100 Bureau Drive, MS 2600
Gaithersburg, MD 20899
Phone: (301) 975-2196
E-mail: tina.butcher@nist.gov

Jerry Butler

North Carolina Department of Agriculture
1050 Mail Service Center
Raleigh, NC 27699-1050
Phone: (919) 707-3225
E-mail: jerry.butler@ncagr.gov

Brent Calcutt

Afton Chemical
2000 Town Center Drive, Ste 1160
Southfield, MI 48075
Phone: (248) 350-0640
E-mail: brent.calcut@aftonchemical.com

David Calix

NCR Corporation
1510 North Walton Boulevard
Bentonville, AR 72712
Phone: (479) 372-8407
E-mail: david.calix1976@gmail.com

Bill Callaway

Crompco
1815 Gallagher Road
Plymouth Meeting, PA 19067
Phone: (610) 256-7185
E-mail: bill.callaway@crompco.com

Todd Campbell

Clean Energy
4675 MacArthur Boulevard
Newport Beach, CA 92660
Phone: (949) 437-1201
E-mail: tcampbell@cleanenergyfuels.com

Loretta Carey

U.S. Food & Drug Administration
5100 Paint Branch Parkway
College Park, MD 20740
Phone: (240) 402-1799
E-mail: loretta.carey@fda.hhs.gov

Stacy Carlsen

Marin County Weights & Measures
1682 Novato Boulevard, Ste 150-A
Novato, CA 94947-7021
Phone: (415) 473-6700
E-mail: scarlsen@marincounty.org

Tim Carmichael

CA NGV Coalition
1029 K Street, #24
Sacramento, CA 95814
Phone: (916) 448-0015
E-mail: tim@cngvc.org

Charlie Carroll

Massachusetts Division of Standards
One Ashburton Place, Rm 1115
Boston, MA 02108
Phone: (617) 727-3480
E-mail: charles.carroll@state.ma.us

Jimmy Cassidy

City of Cambridge Weights & Measures Department
831 Massachusetts Avenue
Cambridge, MA 02139
Phone: (617) 349-6133
E-mail: jcassidy@cambridgema.gov

Chris Chamberlain

Michigan Department of Agric. & Rural Development
940 Venture Lane
Williamston, MI 48895-2451
Phone: (517) 655-8202
E-mail: chamberlainc@michigan.gov

Clarence Chee

Navajo Nation Business Regulatory Department
PO Box 663
Window Rock, AZ 86515
Phone: (928) 871-6718
E-mail: locohorse99@yahoo.com

Tim Chesser

Arkansas Bureau of Standards
4608 West 61st Street
Little Rock, AR 72209
Phone: (501) 570-1159
E-mail: tim.chesser@aspb.ar.gov

Maura Cirilli

PBF Energy
4550 Wrangle Hill Road
Delaware City, DE 19706
Phone: (302) 834-6068
E-mail: maura.cirilli@pbfenergy.com

Jeffrey Clarke

NGVAmerica
400 N. Capitol Street
Washington, DC 20001
Phone: (202) 824-7364
E-mail: jclarke@ngvamerica.org

Mike Cleary

4108 Eunice Way
Sacramento, CA 95821
Phone:
E-mail: mcleary55@sbcglobal.net

Clark Cooney

NIST, Office of Weights & Measures
100 Bureau Drive, MS 2600
Gaithersburg, MD 20899
Phone: (301) 975-4615
E-mail: clark.cooney@nist.gov

Rodney Cooper

Tuthill Transfer Systems
8825 Aviation Drive
Fort Wayne, IN 46809
Phone: (260) 755-7552
E-mail: rcooper@tuthill.com

Ronny Cornelis

Curacao Government
Blanquillaweg 94
Curacao, Willemstd,
Phone: (599) 9-517-6669
E-mail: ronny.cornelis@gobiernu.cw

Hayden Cornish

Schenck Process
746 E. Milwaukee Street.
Whitewater, WI 53190
Phone: (262) 473-2441
E-mail: h.cornish@schenckprocess.com

Chuck Corr

Archer Daniels Midland Company
1251 Beaver Channel Parkway
Clinton, IA 52732
Phone: (563) 244-5208
E-mail: corr@adm.com

Constantine Cotsoradis

Flint Hills Resources
4111 East 37th Street North
Wichita, KS 67220-3203
Phone: (316) 828-6133
E-mail: constantine.cotsoradis@fhr.com

Gordon Cox

Institute of Materials
4800 James Savage Road
Midland, MI 48642
Phone: (989) 615-0144
E-mail: gcox@savantgroup.com

Mark Coyne

Brockton Weights & Measures
45 School Street
City Hall
Brockton, MA 02301-9927
Phone: (508) 580-7120
E-mail: mcoyne@cobma.us

Evan Crotty

Michigan Department of Agriculture
940 Venture Lane
Williamston, MI 48895
Phone: (517) 655-8202
E-mail:

Dave Crowley

Michigan Department of Agriculture
940 Venture Lane
Williamston, MI 48895-2451
Phone: (517) 655-8202
E-mail: crowleyd@michigan.gov

Cecil Culbreth

CompuCom
7171 Forest Lane
Dallas, TX 75230
Phone:
E-mail: cecil.culbreth@compucom.com

Matthew Curran

Florida Department of Agriculture & Consumer Services
3125 Conner Boulevard
Building 2, MS L2
Tallahassee, FL 32399-1650
Phone: (850) 921-1570
E-mail: matthew.curran@freshfromflorida.com

Tina Dasbach

Institute of Materials
4800 James Savage Road
Midland, MI 48642
Phone: (989) 496-2301
E-mail: tdasbach@savantgroup.com

Joe Daugherty

Michigan Department of Agriculture
940 Venture Lane
Williamston, MI 48895
Phone:
E-mail:

Jason DeChene

Michigan Department of Agriculture
940 Venture Lane
Williamston, MI 48895
Phone:
E-mail:

J.K. Delahay

Brother International Corporation
200 Crossing Boulevard
Bridgewater, NJ 08807
Phone: (908) 655-9197
E-mail: james.delahay@brother.com

Vicky Dempsey

Montgomery County Weights & Measures
24 North Westview
Dayton, OH 45403
Phone: (937) 307-0072
E-mail: demps5806@aol.com

Rob DeRubeis

Michigan Department of Agriculture & Rural Development
940 Venture Lane
Williamston, MI 48895
Phone: (517) 655-8202
E-mail: derubeisr@michigan.gov

Bette Dixon

Sterling Scale Company
20950 Boening Drive
Southfield, MI 48075
Phone: (800) 331-9931
E-mail: bettedixon@sterlingscale.com

Gary Ebinger

Huron Co Weights & Measures
12 East Main Street, Ste 300
Norwalk, OH 44857-1545
Phone: (419) 668-8643
E-mail: gedinger48@gmail.com

Joe Eccleston IV

Maryland Department of Agriculture
50 Harry S. Truman Parkway
Annapolis, MD 21401
Phone: (410) 841-5790
E-mail: ecclesjo@mda.state.md.us

Chuck Ehrlich

NIST, Office of Weights & Measures
100 Bureau Drive, MS 2600
Gaithersburg, MD 20899-2600
Phone: (301) 975-4834
E-mail: charles.ehrlich@nist.gov

Jeff Fantozzi

Erie County Auditor's Office
247 Columbus Avenue, #210
Sandusky, OH 44870
Phone: (419) 627-6650
E-mail: atozhi1@yahoo.com

Bob Feezor

Scales Consulting & Testing
35 Stonington Place
Marietta, GA 30068
Phone: (770) 971-7454
E-mail: rkfeezor@bellsouth.net

Scott Ferguson

Michigan Department of Agriculture & Rural
Development
940 Venture Lane
Williamston, MI 48895-2451
Phone: (517) 655-8202
E-mail: fergusons9@michigan.gov

Kevin Ferrick

API
1220 L Street NW
Washington, DC 20005
Phone: (202) 682-8233
E-mail: ferrick@api.org

Benj Fitzpatrick

Minnesota Weights & Measures
14305 Southcross Drive, #150
Burnsville, MN 55306
Phone: (651) 539-1560
E-mail: benjamin.fitzpatrick@state.mn.us

Mark Flint

Archer Daniels Midland
4666 Faries Parkway
Decatur, IL 62526
Phone: (217) 451-3104
E-mail: mark.flint@adm.com

Darrell Flocken

National Conference on Weights & Measures, Inc.
1135 M Street, Ste 110
Lincoln, NE 68508
Phone: (614) 620-6134
E-mail: darrell.flocken@ncwm.net

Kurt Floren

LA County Agricultural Commissioner
Weights & Measures
12300 Lower Azusa Road
Arcadia, CA 91006
Phone: (626) 575-5451
E-mail: kfloren@acwm.lacounty.gov

John Gaccione

Westchester County Weights & Measures
148 Martine Avenue, Rm 407
White Plains, NY 10601
Phone: (914) 995-2164
E-mail: jpg4@westchestergov.com

Steve Galvan

Michigan Department of Agric. & Rural Development
940 Venture Lane
Williamston, MI 48895
Phone: (517) 622-8202
E-mail: galvans@michigan.gov

Win Gardner

ExxonMobil Corporation
3225 Gallows Road, Rm 6D0416
Fairfax, VA 22037
Phone: (703) 846-5400
E-mail: k.w.gardner@exxonmobil.com

Nathan Gardner

Oregon Department of Agriculture
635 Capitol Street NE
Salem, OR 97301
Phone: (503) 986-4764
E-mail: ngardner@oda.state.or.us

Tom Geiler

313 Riverview Lane
Centerville, MA 02632
Phone: (508) 294-1358
E-mail: tomgeiler56@gmail.com

Bill Geubelle

Phillips 66
1000 S Pine
Ponca City, OK 74602
Phone: (580) 767-3400
E-mail: bill.g.geubelle@p66.com

Ron Gibson

Seraphin Test Measure
30 Indel Avenue
Rancocas, NJ 08073
Phone: (609) 267-0922
E-mail: rgibson@pemfab.com

Steve Giguere

Maine Department of Agriculture, Conservation &
Forestry
28 State House Station
Augusta, ME 04333
Phone: (207) 287-4456
E-mail: steve.giguere@maine.gov

Jason Glass

Kentucky Department of Agriculture
107 Corporate Drive
Frankfort, KY 40601
Phone: (502) 573-0282
E-mail: jason.glass@ky.gov

Tom Glenn

Petroleum Quality Institute of America
Metuchen, NJ
Phone:
E-mail:

Angela Godwin

Ventura County Department of Weights & Measures,
California
800 S Victoria Avenue, #1750
Ventura, CA 93009
Phone: (805) 654-2428
E-mail: angela.godwin@ventura.org

Joe Gomez

New Mexico Department of Agriculture
P.O. Box 30005
MSC 3170
Las Cruces, NM 88003-8005
Phone: (575) 646-1616
E-mail: jgomez@nmda.nmsu.edu

Shawn Good

Rail Scale, Inc.
5303 N 800 E
Wilkinson, IN 46186
Phone: (317) 339-6486
E-mail: shawn@railscale.com

Larry Goodbar

Yamato Corporation
1775 S Murray Boulevard
Colorado Springs, CO 80916
Phone: (719) 457-3166
E-mail: goodbar@yamatoCorp.com

Steve Grabski

Walmart Stores, Inc.
508 SW 8th Street, MS 0505
Bentonville, AR 72716
Phone: (479) 277-8005
E-mail: steven.grabski@walmart.com

Frank Greene

Connecticut Dept of Consumer Protection
165 Capitol Avenue
Hartford, CT 06106
Phone: (860) 713-6168
E-mail: frank.greene@ct.gov

Chris Guay

Procter & Gamble Co.
One Procter & Gamble Plaza
Cincinnati, OH 45202
Phone: (513) 983-0530
E-mail: guay.cb@pg.com

Philip Guillemette

Flint Hills Resources, LP
4111 East 37th Street North
Wichita, KS 67220
Phone: (316) 828-8440
E-mail: philip.guillemette@fhr.com

Brett Gurney

Utah Department of Agriculture & Food
P.O. Box 146500
Salt Lake City, UT 84114-6500
Phone: (801) 538-7158
E-mail: bgurney@utah.gov

Carrie Haler

Pier 1 Imports
100 Pier 1 Place
Fort Worth, TX 76102
Phone: (817) 252-8176
E-mail: cahaler@pier1.com

John Halliwell

Electric Power Research Institute
942 Corridor Park Boulevard
Knoxville, TN 37932
Phone: (865) 218-8149
E-mail: jhalliwell@epri.com

Ivan Hankins

Iowa Department of Agriculture/Weights & Measures
2230 S. Ankeny Boulevard
Ankeny, IA 50023-9093
Phone: (515) 725-1492
E-mail: ivan.hankins@iowaagriculture.gov

Krister Hard af Segerstad

IKEA North America Services, LLC
420 Alan Wood Road
Conshohocken, PA 19428
Phone: (610) 834-0180
E-mail: krister.hardafsegerstad0@ikea.com

Jeff Harmening

American Petroleum Institute
1220 L Street NW
Washington, DC 20005
Phone: (202) 682-8310
E-mail: harmeningj@api.org

Steven Harrington

Oregon Weights & Measures
635 Capitol Street NE
Salem, OR 97301
Phone:
E-mail: sharrington@oda.state.or.us

Rick Harshman

NIST, Office of Weights & Measures
100 Bureau Drive, MS 2600
Gaithersburg, MD 20899-2600
Phone: (301) 975-8107
E-mail: richard.harshman@nist.gov

Ryanne Hartman

Michigan Department of Agriculture & Rural Development
940 Venture Lane
Williamston, MI 48895-2451
Phone: (517) 655-8202
E-mail: hartmanr4@michigan.gov

Ron Hayes

Missouri Department of Agriculture
1616 Missouri Boulevard
P.O. Box 630
Jefferson City, MO 65102
Phone: (573) 751-4316
E-mail: ron.hayes@mda.mo.gov

Jon Heinlein

Transcell Technology, Inc.
975 East Deerfield Parkway
Buffalo Grove, IL 60089
Phone: (847) 419-9180
E-mail: jheinlein@transcell.com

Loretta Helwig

Michigan Department of Agriculture
940 Venture Lane
Williamston, MI 48895-2451
Phone: (517) 655-8202
E-mail:

Joe Henmueller

MAP - The Motorist Assurance Program
725 E Dundee Road, Ste 206
Arlington Heights, IL 60004
Phone: (847) 947-2650
E-mail: jmh@motorist.org

Scott Henry

Motorola Solutions, Inc.
721 Richmond Court
Loganville, GA 30052
Phone: (770) 466-3658
E-mail: scott.henry@motorolasolutions.com

Marilyn Herman

Herman & Associates
3730 Military Road NW
Washington, DC 20015
Phone: (202) 362-9520
E-mail: mherman697@aol.com

Jim Hewston

J.A. King & Co
6541 C Franz Warner Parkway
Whitsett, NC 27377
Phone: (402) 517-0794
E-mail: jim.hewston@jaking.com

Catharine Hinkley

Michigan Department of Agriculture & Rural
Development
940 Venture Lane
Williamston, MI 48895-2451
Phone: (517) 655-8202
E-mail: hinkleyc@michigan.gov

Carol Hockert

NIST, Office of Weights & Measures
100 Bureau Drive, MS 2600
Gaithersburg, MD 20899-2600
Phone: (301) 975-4004
E-mail: carol.hockert@nist.gov

Jerry Horn

Chevron Global Downstream, LLC
100 Chevron Way, Rm 61-4228
Richmond, CA 94802
Phone: (510) 242-1367
E-mail: jerryhorn@chevron.com

Bill Hornbach

Chevron Products Company
6001 Bollinger Canyon Road
San Ramon, CA 94583
Phone: (925) 842-3484
E-mail: billhornbach@chevron.com

Justin Houghton

Michigan Department of Agriculture
940 Venture Lane
Williamston, MI 48895
Phone:
E-mail:

Fran Houston

Ohio Department of Agriculture Division of Weights
& Measures
8995 East Main Street
Reynoldsburg, OH 43068
Phone: (614) 728-6290
E-mail: houston@agri.ohio.gov

John Hughes

Rice Lake Weighing
230 W Coleman Street
Rice Lake, WI 54868
Phone: (507) 399-4629
E-mail: jhughes@ricelake.com

Lori Jacobson

South Dakota Weights & Measures
118 W Capitol
Pierre, SD 57501
Phone: (605) 773-3697
E-mail: lori.jacobson@state.sd.us

David Jaskolski

Pivotal LNG
1874 Ramblers Road Inn
Jefferson, GA 30549
Phone: (404) 783-3550
E-mail: david.jaskolski@pivotalng.com

Randy Jennings

Tennessee Department of Agriculture
P.O. Box 40627
Melrose Station
Nashville, TN 37204
Phone: (615) 837-5327
E-mail: randy.jennings@tn.gov

Jeff Jetter

Honda R&D Americas, Inc.
1900 Harpers Way
Torrance, CA 90501
Phone: (310) 994-0713
E-mail: jjetter@hira.com

Rafael Jimenez

Association of American Railroad Transportation
Technology Center
P.O. Box 11130
55500 D.O.T. Road
Pueblo, CO 81001
Phone: (719) 584-0691
E-mail: rafael_jimenez@ttci.aar.com

Joanna Johnson

Johnson Policy Associates, Inc.
P.O. Box 13302
Des Moines, IA 50310
Phone: (515) 277-4320
E-mail: jpa.inc@earthlink.net

Gordon Johnson

Gilbarco, Inc.
7300 West Friendly Avenue
Greensboro, NC 27410
Phone: (336) 547-5375
E-mail: gordon.johnson@gilbarco.com

Raymond Johnson Jr.

New Mexico Department of Agriculture
P.O. Box 30005
MSC 3170
Las Cruces, NM 88003-8005
Phone: (575) 646-1616
E-mail: rjohnson@nmda.nmsu.edu

Zina Juroch

Pier 1 Imports
100 Pier 1 Place
Fort Worth, TX 76102
Phone: (817) 252-8348
E-mail: zmjuroch@pier1.com

Jeri Kahana

Hawaii Department of Agriculture
1851 Auiki Street
Honolulu, HI 96819
Phone: (808) 832-0707
E-mail: jeri.Mm.kahana@hawaii.gov

Norm Kanar

SavanTech
4800 James Savage
Midland, MI 48642
Phone: (989) 496-2301
E-mail:

Dmitri Karimov

Liquid Controls
105 Albrecht Drive
Lake Bluff, IL 60044
Phone: (847) 283-8317
E-mail: dkarimov@idexcorp.com

Michael Keilty

Endress + Hauser Flowtec AG USA
2441 Arapaho Road
Estes Park, CO 80517
Phone: (970) 586-2122
E-mail: michael.keilty@us.endress.com

Henry Kellogg

Compucom
2 Cromer Drive
Bella Vista, AR 72715
Phone: (479) 685-6862
E-mail: henry.kellogg@compucom.com

Michael Kerr

Southern Company Services
228 Bridle Run
Somerset, KY 42503
Phone: (606) 305-2419
E-mail: mlkerr@southernco.com

Jack Kiefert

Honeywell Enraf
1545 Shagbark Way
Cumming, GA 30041
Phone: (404) 414-7523
E-mail: jack.kiefert@honeywell.com

Doug Killingsworth

Georgia Department of Agriculture
19 M.L.K. Jr. Drive SW
Atlanta, GA 30334
Phone: (404) 656-3605
E-mail: william.killingsworth@agr.georgia.gov

Brian King

Wood Co Weights & Measures
One Courthouse Square
Bowling Green, OH 43402
Phone: (419) 354-9150
E-mail: bking@co.wood.oh.us

Steve Kleer

Marathon Petroleum Company, LP
2990 South Dixie Highway
Lima, OH 45804
Phone: (419) 228-2049
E-mail: sjkleer@marathonpetroleum.com

Jean Kliethermes

Missouri Department of Agriculture
PO Box 630
Jefferson City, MO 65102
Phone: (573) 751-5638
E-mail: jean.kliethermes@mda.mo.gov

Tom Konst

Carroll County Auditor
119 S Lisbon Street, Ste 203
Carrollton, OH 44615
Phone: (330) 627-2096
E-mail: tfkonst@hotmail.com

David Kovach

BP
150 W. Warrenville Road
MC J-7
Naperville, IL 60563
Phone:
E-mail: david.kovach@bp.com

Mike Kunselman

Center for Quality Assurance
4800 James Savage Road
Midland, MI 48642
Phone: (989) 496-2399
E-mail: mkunselman@CenterForQA.com

Ryan Lamberg

National Biodiesel Board
749 Guerrero Street
San Francisco, CA 94110
Phone: (415) 418-0964
E-mail: rlamberg@biodiesel.org

Stephen Langford

Cardinal Scale Manufacturing Co.
203 East Daugherty Street
P.O. Box 151
Webb City, MO 64870
Phone: (417) 673-4631
E-mail: slangford@cardet.com

Chris Lecompte

Michigan Department of Agriculture
940 Venture Lane
Williamston, MI 48895-2451
Phone: (517) 655-8202
E-mail: lecomptec@michigan.gov

James Lee

Michigan Department of Agriculture
940 Venture Lane
Williamston, MI 48895-2451
Phone: (517) 655-8202
E-mail:

Robert Legg

Southwest Research Institute
6220 Culebra Road
San Antonio, TX 78238
Phone: (210) 522-2071
E-mail: robert.legg@swri.org

Russ Lewis

Marathon Petroleum Company LP
2901 Camelia Drive
Flatwoods, KY 41139
Phone: (606) 921-2009
E-mail: rplewis@marathonpetroleum.com

Rich Lewis

Georgia Department of Agriculture
Agriculture Building
19 MLK Drive, Rm 321
Atlanta, GA 30334
Phone: (404) 656-3605
E-mail: richard.lewis@agr.georgia.gov

Paul Lewis

Rice Lake Weighing Systems, Inc.
230 West Coleman Street
Rice Lake, WI 54868-2404
Phone: (715) 434-5322
E-mail: plewis@ricelake.com

Tom Light

Sandusky Co Weights & Measures
100 N Park Avenue Courthouse, Ste 228
Fremont, OH 43420
Phone: (419) 334-6129
E-mail: light_tom@co.sandusky.oh.us

Tim Lloyd

Montana Weights & Measures Bureau
P.O. Box 200516
Helena, MT 59620-0516
Phone: (406) 443-3289
E-mail: tlloyd@mt.gov

Robert Lopez

San Luis Obispo County Weights & Measures
2156 Sierra Way, Ste A
San Luis Obispo, CA 93401
Phone: (805)781-5910
E-mail: rnlopez@co.slo.ca.us

Tom Ludi

Hancock County Weights & Measures Courthouse
300 S Main Street
Findlay, OH 45840
Phone: (419)424-7240
E-mail: teludi@co.hancock.oh.us

Girard Lukowiak

City of East Orange
143 New Street
East Orange, NJ 07017
Phone: (201) 953-4260
E-mail: glukowiak@gmail.com

Ed Luthy

Schenck Process, Inc
108 Wade Drive
Dover, OH 44622
Phone: (440) 241-0194
E-mail: e.luthy@schenckprocess.com

Mike Lynch

ExxonMobil
600 Billingsport Road
Paulsboro, NJ 08066
Phone: (856) 224-2634
E-mail: michael.j.lynch@exxonmobil.com

Andrew MacAllister

Daniel Measurement & Control, Inc.
11100 Brittmoore Park Drive
Houston, TX 77041
Phone: (713) 827-4334
E-mail: andrew.macallister@emerson.com

Kristin Macey

California Division of Measurement Standards
6790 Florin Perkins Road, Ste 100
Sacramento, CA 95828
Phone: (916) 229-3000
E-mail: kristin.macey@cdfa.ca.gov

Matthew Maiten

Santa Barbara County Agriculture Commissions
263 Camino del Remedio
Santa Barbara, CA 93110
Phone: (805) 681-5600
E-mail: mmaiten@agcommissioner.com

Marco Mares

San Diego County Dept of Agriculture, Weights & Measures
9325 Hazard Way, Ste 100
San Diego, CA 92123-1256
Phone: (858) 614-7726
E-mail: marco.mares@sdcounty.ca.gov

Rich McComas

West Virginia Weights & Measures Division of Labor
570 McCorkle Avenue West
St. Albans, WV 25177
Phone: (304) 722-0602
E-mail: rich.d.mccomas@wv.gov

Jim McGetrick

BP Products
Mail Code J-8
150 W. Warrenville Road
Naperville, IL 60563
Phone: (630) 487-1685
E-mail: james.mcgetrick@bp.com

John McGuire

New Jersey State Office of Weights & Measures
1261 Routes 1 & 9 South
Avenel, NJ 07001
Phone: (732) 815-7800
E-mail: john.mcguire@lps.state.nj.us

Sean McGuire

Michigan Department of Agriculture & Rural Development
940 Venture Lane
Williamston, MI 48895-2451
Phone: (517) 655-8202
E-mail: mcguires1@michigan.gov

Paul Menard

Lexmark International
740 West New Circle Road
501C14/082-1
Lexington, KY 40550
Phone: (859) 232-7379
E-mail: menard@lexmark.com

Dominic Meyer

KSi Conveyors, Inc.
2345 U Road
Sabetha, KS 66534
Phone: (785) 284-0600
E-mail: dmeyer@ksiconveyors.com

Shelly Miller

Wisconsin Department of Agriculture & Consumer Protection
N 3303 County Road E
Sullivan, WI 53178
Phone: (608) 516-5362
E-mail: rachelle.miller@wisconsin.gov

Kristy Moore

Renewable Fuels Association
425 3rd Street, SW, Ste 1150
Washington, DC 20024
Phone: (309) 830-6154
E-mail: kmoore@ethanolrfa.org

Marcus Moore

ExxonMobil
3225 Gallows Road, Rm 6B2117
Fairfax, VA 22037
Phone: (703) 846-1529
E-mail: marcus.moore@exxonmobil.com

Joe Moreo

Modoc County Department of Agriculture
202 West Fourth Street
Alturas, CA 96101
Phone: (530) 233-6401
E-mail: susiephilpott@co.modoc.ca.us

Steve Mulvaney

Chevron
Richmond, CA
Phone:
E-mail:

Bob Murnane

Seraphin Test Measure, Co.
30 Indel Avenue
P.O. Box 227
Rancocas, NJ 08073-0227
Phone: (609) 267-0922
E-mail: rmurnane@pemfab.com

Peter Murray

Chart Inc.
2200 Airport Industrial Boulevard, Bldg. 500
Ball Ground, GA 30107
Phone: (678) 467-5484
E-mail: peter.murray@chartindustries.com

Doug Musick

Kansas Department of Agriculture
1320 Research Park Drive
Manhattan, KS 66502
Phone: (785) 564-6700
E-mail: Doug.Musick@KDA.KS.Gov

Dianne Naggard

Michigan Department of Agriculture
940 Venture Lane
Williamston, MI 48895-2451
Phone: (517) 655-8202
E-mail: Naggard@michigan.gov

Brendan Neill

Green Buffalo Fuel, LLC
720 Riverview Boulevard
Tonawanda, NY 14150
Phone:
E-mail: bneill@greenbuffalofuel.com

Laurence Nolan

LA County Agriculture Commission/Weights & Measures
11012 Garfield Avenue
South Gate, CA 90280
Phone: (562) 940-8936
E-mail: lnolan@acwm.lacounty.gov

Neal Nover

WinWam Software
3000 Atrium Way, Ste 2203
Mount Laurel, NJ 08054-3910
Phone: (856) 273-6988
E-mail: NealNov@winwam.com

Don Onwiler

National Conference on Weights & Measures, Inc
1135 M Street, Ste 110
Lincoln, NE 68508
Phone: (402) 434-4871
E-mail: don.onwiler@ncwm.net

Henry Opperma

Weights & Measures Consulting, LLC
1300 Peniston Street
New Orleans, LA 70115
Phone: (504) 896-9172
E-mail: wm-consulting@att.net

James Oswald

Michigan Department of Agriculture & Rural Development
940 Venture Lane
Williamston, MI 48895-2451
Phone: (517) 655-8202
E-mail: oswaldj@michigan.gov

Dave Packard

ChargePoint, Inc.
406 Seagrove Street
St. Marys, GA 31558
Phone: (912) 258-5665
E-mail: dave.packard@chargepoint.com

Brian Parnell

MAPCO Express, Inc.
7102 Commerce Way
Brentwood, TN 37027
Phone: (615) 224-1169
E-mail: gbparn.ncwm@gmail.com

Bimal Patel

Wayne, A GE Energy Business
3814 Jarrett Way
Austin, TX 78728
Phone: (512) 238-3720
E-mail: bimals.patel@ge.com

Dan Peterson

Yokogawa Corporation of America
2 Dart Road
Newnan, GA 30265
Phone: (770) 254-0400
E-mail: dan.peterson@us.yokogawa.com

Howard Pine

New Jersey Weights & Measures
1261 Routes 1 & 9 South
Avenel, NJ 07001
Phone: (732) 815-7805
E-mail: pineh@dca.lps.state.nj.us

Richard Price

Butte County Weights & Measures
316 Nelson Avenue
Oroville, CA 95965
Phone: (530) 538-7381
E-mail: rprice@buttecounty.net

Hal Prince

Florida Dept of Agriculture & Consumer Services
6626 Lake Kirkland Drive
Clermont, FL 34714
Phone: (850) 921-1570
E-mail: harold.prince@freshfromflorida.com

Julie Quinn

Minnesota Department of Commerce
14305 South Cross Drive, Ste 150
Burnsville, MN 55306
Phone: (651) 539-1555
E-mail: julie.quinn@state.mn.us

Dave Rajala

Total Meter Services, Inc.
136 Queen Anne Drive
Hollidaysburg, PA 16648-9228
Phone: (814) 693-1055
E-mail: drajala@totalmeter.com

Ken Ramsburg

Maryland Department of Agriculture
50 Harry S. Truman Parkway
Annapolis, MD 21401
Phone: (410) 841-5790
E-mail: kenneth.ramsburg@maryland.gov

Doug Rathbun

Illinois Department of Agriculture
801 Sangamon Avenue
P.O. Box 19281
Springfield, IL 62794-9281
Phone: (217) 785-8300
E-mail: doug.rathbun@illinois.gov

Ulrich Rauchschalbe

Schenck Process GmbH
Pallaswiesenstr. 100
Darmstadt, D-64293
Phone: 49-6151-1531-3374
E-mail: u.rauchschalbe@schenckprocess.com

Doug Raymond

Raymond Regulatory Resources/NAA
5857 Trumbull Road
Geneva, OH 44041
Phone: (440) 474-4999
E-mail: djraymond@reg-resources.com

Tyler Reeder

National Conference on Weights & Measures, Inc.
1135 M Street, Ste 110
Lincoln, NE 68508
Phone: (402) 434-4880
E-mail: tyler.reeder@ncwm.net

Derek Regal

Tesoro Companies, Inc.
19100 Ridgewood Parkway
San Antonio, TX 78259
Phone: (210) 626-7317
E-mail: derek.b.regal@tsocorp.com

Wayne Reinert

Colorado Oil & Public Safety
633 17th Street
Denver, CO 80202
Phone: (303) 883-8323
E-mail: wayne.reinert@state.co.us

Walt Remmert

Pennsylvania Department of Agriculture Bureau of
Weights & Measures
2301 North Cameron Street
Harrisburg, PA 17110
Phone: (717) 787-9089
E-mail: wremmert@pa.gov

Bob Reynolds

Downstream Alternatives, Inc.
4204 Coral Drive
South Bend, IN 46614
Phone: (574) 250-2811
E-mail: rreynoldsdai@att.net

Rebecca Richardson

MARC IV Consulting
2005 Tin Cup Road
Mahomet, IL 61853
Phone: (217) 419-3543
E-mail: rrichardson@marciv.com

Charlie Riedl

ANGA
701 8th Street NW
Washington, DC 20001
Phone: (614) 980-3341
E-mail: criedl@anga.us

Bill Ripka

Thermo Fisher Scientific
501 90th Avenue NW
Minneapolis, MN 55433
Phone: (800) 445-3503
E-mail: bill.ripka@thermofisher.com

Lance Robertson

Measurement Canada
151 Tunney's Pasture Driveway
Ottawa, ON K1A 0C9
Phone: (613) 952-0661
E-mail: lance.robertson@ic.gc.ca

Gene Robertson

Mississippi Dept. of Agriculture & Commerce
P.O. Box 1609
Jackson, MS 39215-1609
Phone: (601) 359-1111
E-mail: gene@mdac.state.ms.us

Hector Santini

Motorola Solutions
9733 Fredericksburg Road
Tampa, FL 33635
Phone: (813) 220-9174
E-mail: hector.santini@motorolasolutions.com

Nick Santini

Michigan Department of Agriculture
940 Venture Lane
Williamston, MI 48895
Phone: (517) 655-8202
E-mail: santinin@michigan.gov

Dale Saunders

Virginia Department of Agriculture & Consumer
Services-Weights & Measures
P.O. Box 1163
Richmond, VA 23219
Phone: (804) 786-2476
E-mail: dale.saunders@vdacs.virginia.gov

Richard Scali

Town of Barnstable
200 Main Street
Hyannis, MA 02601
Phone: (508) 862-4778
E-mail: richard.scali@town.barnstable.ma.us

Bruce Schultz

Michigan Department of Agriculture
940 Venture Lane
Williamston, MI 48895-2451
Phone: (517) 655-8202
E-mail: schultzbl@michigan.gov

David Sefcik

NIST, Office of Weights & Measures
100 Bureau Drive, MS 2600
Gaithersburg, MD 20899-2600
Phone: (301) 975-4868
E-mail: david.sefcik@nist.gov

Dick Shipman

Rice Lake Weighing Systems
230 West Coleman Street
Rice Lake, WI 45868
Phone: (715) 234-9171
E-mail: rshipman@ricelake.com

Jenny Sigelko

Volkswagen Group of America
3800 Hamlin Road
Auburn Hills, MI 48326
Phone: (248) 754-4214
E-mail: jenny.sigelko@vw.com

Joseph Silvestro

Gloucester County New Jersey
64 Forage Drive
Mickleton, NJ 08056
Phone: (856) 423-5360
E-mail: silver7777@comcast.net

Scott Simmons

Colorado Oil & Public Safety
633 17th Street, Ste 500
Denver, CO 80202
Phone: (303) 378-1103
E-mail: scott.simmons@state.co.us

Larry Simon

Monterey County Deputy Sealer
1428 Abbott Street
Salinas, CA 93901
Phone: (831) 759-7310
E-mail: simonll@co.monterey.ca.us

Dan Smith

Alaska Division of Measurement Standards/CVE
11900 Industry Way, Bldg. M, Ste 2
Anchorage, AK 99515
Phone: (907) 365-1210
E-mail: dan.smith1@alaska.gov

N. David Smith

North Carolina Department of Agriculture
1050 Mail Service Center
Raleigh, NC 27699-1050
Phone: (919) 707-3033
E-mail: david.smith@ncagr.gov

Erica Steinlein

Trader Joe's
800 South Shamrock Avenue
Monrovia, CA 91016
Phone: (626) 599-3763
E-mail: esteinlein@traderjoes.com

Brad Stotler

NATSO, Representing America's Travel Plazas & Truckstops
1737 King Street, Ste 200
Alexandria, VA 22314
Phone: (202) 309-0400
E-mail: bstotler@natso.com

Lou Straub

Fairbanks Scales, Inc.
3056 Irwin Drive S.E.
Southport, NC 28461
Phone: (910) 253-3250
E-mail: lstraub@fairbanks.com

Elisa Stritt

National Conference on Weights & Measures, Inc
1135 M Street, Ste 110
Lincoln, NE 68508
Phone: (402) 434-4872
E-mail: elisa.stritt@ncwm.net

Bill Studzinski

General Motors - Powertrain Division
823 Joslyn Road
Mailcode: 483-730-472
Pontiac, MI 48340
Phone: (248) 255-7785
E-mail: william.studzinski@gm.com

Larry Stump

Indiana State Department of Health
2525 N. Shadeland Avenue, #03
Indianapolis, IN 46219-1791
Phone: (317) 356-7078
E-mail: lstump@isdh.in.gov

Dick Suiter

Richard Suiter Consulting
9819 Anchor Bend
McCordsville, IN 46055
Phone: (317) 336-9819
E-mail: Rsuiter700@aol.com

Jennifer Thompson

Mississippi Department of Agriculture & Commerce
P.O. Box 1609
Jackson, MS 39215-1609
Phone: (601) 359-1144
E-mail: jennifer@mdac.state.ms.us

Ken Tichota

FSCP - Weights & Measures
301 Centennial Mall South
P.O. Box 94757
Lincoln, NE 68509-4757
Phone: (402) 471-3422
E-mail: ken.tichota@nebraska.gov

Gary Titus

Michigan Department of Agriculture
940 Venture Lane
Williamston, MI 48895-2451
Phone: (517) 655-8202
E-mail:

Stan Toy

Santa Clara County Weights & Measures
1553 Berger Dr
Building 1, 2nd Floor
San Jose, CA 95112
Phone: (408) 918-4633
E-mail: stan.toy@aem.sccgov.org

Beth Treseder

API
1220 L Street, NW
Washington, DC 20005
Phone: (202) 682-8172
E-mail: tresedere@api.org

Jim Truex

National Conference on Weights & Measures, Inc
88 Carryback Drive
Pataskala, OH 43062
Phone: (740) 919-4350
E-mail: jim.truex@ncwm.net

Rich Tucker

RL Tucker Consulting, LLC
605 Bittersweet Lane
Ossian, IN 46777
Phone: (260) 622-4243
E-mail: rtucker83@comcast.net

Rob Underwood

Petroleum Marketers Association of America
1901 N Fort Myer Drive, Ste 500
Arlington, VA 22209
Phone: (703) 351-8000
E-mail: runderwood@pmaa.org

Rob Upright

Vishay Transducers
42 Countryside Road
North Grafton, MA 01536
Phone: (508) 615-1185
E-mail: rob.upright@vishaypg.com

Kevin Upschulte

Missouri Department of Agriculture
1616 Missouri Boulevard
P.O. Box 630
Jefferson City, mo 65102
Phone: (573) 751-4316
E-mail: kevin.upschulte@mda.mo.gov

Marie Valentine

Toyata--TEMA
1555 Woodridge
Ann Arbor, MI 48105
Phone: (734) 995-3692
E-mail: marie.valentine@tema.toyota.com

Craig VanBuren

Michigan Department of Agriculture & Rural
Development
940 Venture Lane
Williamston, MI 48895-2451
Phone: (517) 655-8202
E-mail: vanburenc9@michigan.gov

Claudia Verdugo

San Diego County Department of Agriculture
9325 Hazard Way, Ste 100
San Diego, CA 92123-1217
Phone: (858) 694-2778
E-mail: claudia.verdugo@sdcounty.ca.gov

Willem Vilders

Michigan Department of Agriculture
940 Venture Lane
Williamston, MI 48895-2451
Phone: (517) 655-8202
E-mail:

Gilles Vinet

Measurement Canada
151 Tunney's Pasture Driveway
Ottawa, ON K1A 0C9
Phone: (613) 941-8918
E-mail: gilles.vinet@ic.gc.ca

Russ Vires

Mettler-Toledo, LLC
1150 Dearborn Drive
Worthington, OH 43085
Phone: (614) 438-4306
E-mail: russ.vires@mt.com

Jack Walsh

Town of Wellesley
525 Washington Street
Town Hall Wellesley
Wellesley, MA 02482
Phone: (774) 279-2559
E-mail: JackBWalsh@verizon.net

Lisa Warfield

NIST, Office of Weights & Measures
100 Bureau Drive, MS 2600
Gaithersburg, MD 20899-2600
Phone: (301) 975-3308
E-mail: lisa.warfield@nist.gov

Tommy Watson

Flint Hills Resources
2825 Suntide Road
P.O. Box 2608
Corpus Christi, TX 78409
Phone: (361) 242-7328
E-mail: tommy.watson@fhr.com

Chester Watson

Kentucky Department of Agriculture
107 Corporate Drive
Frankfort, KY 40601
Phone: (502) 573-0282
E-mail: chester.watson@ky.gov

Bob Weidler

Wyoming Department of Agriculture
2219 Carey Avenue
Cheyenne, WY 82002
Phone: (307) 777-7556
E-mail: robert.weidler@wyo.gov

Gordon Wenk

Michigan Dept. of Agriculture & Rural Development
525 West Allegan Street
Lansing, MI 48909
Phone: (517) 284-5718
E-mail: wenkg@michigan.gov

Zac Wester

Transfuel dba Blu
3760 Commons Lane
Salt Lake City, UT 84010
Phone: (385) 414-5657
E-mail: zachary.wester@blulng.com

Tim White

Michigan Department of Agriculture & Rural
Development
940 Venture Lane
Williamston, MI 48895-2451
Phone: (517) 655-8202
E-mail: whitet@michigan.gov

John Willer

Michigan Department of Agriculture & Rural
Development
940 Venture Lane
Williamston, MI 48895-2451
Phone: (517) 655-8202
E-mail: willerj1@michigan.gov

Juana Williams

NIST, Office of Weights & Measures
100 Bureau Drive, MS 2600
Gaithersburg, MD 20899-2600
Phone: (301) 975-3989
E-mail: juana.williams@nist.gov

Bob Williams

Tennessee Department of Agriculture
P.O. Box 40627
Melrose Station
Nashville, TN 37204-0627
Phone: (615) 837-5109
E-mail: robert.g.williams@tn.gov

Sergio Williams

Michigan Department of Agriculture & Rural
Development
940 Venture Lane
Williamston, MI 48895-2451
Phone: (517) 655-8202
E-mail: williamss51@michigan.gov

Michelle Wilson

Arizona Department of Weights & Measures
4425 West Olive Avenue, Ste 134
Glendale, AZ 85302
Phone: (602) 771-4933
E-mail: mwilson@azdwm.gov

Sandra Wilson

Michigan Department of Agriculture & Rural
Development
940 Venture Lane
Williamston, MI 48895-2451
Phone: (517) 655-8202
E-mail: wilsons7@michigan.gov

Cary Woodward

Hamilton County Weights & Measures Hamilton
County Judicial Center
1717 Pleasant Street, Ste 150
Noblesville, IN 46060
Phone: (317) 403-0639
E-mail: cary.woodward@hamiltoncounty.in.gov

Philip Wright

Texas Dept. of Ag.
P.O. Box 12847
Austin, TX 78711
Phone: (512) 463-5706
E-mail: philip.wright@texasagriculture.gov

Al Wujcik

PBF Energy
305 Winterhaven Drive
Wilmington, DE 19803
Phone: (302) 893-2569
E-mail: alexander.wujcik@pbfenergy.com

John Young

Yolo County Agriculture Department
70 Cottonwood Street
Woodland, CA 95695
Phone: (530) 666-8148
E-mail: john.young@yolocounty.org

Gary Young

OV Scale & Instruments
P.O. Box 641
Carnegie, PA 15106
Phone: (412) 279-6155
E-mail: gyoung@ovscale.com

Scott Zaremba

Zarco USA Inc
1548 East 23rd, Ste C
Lawrence, KS 66046-5117
Phone: (785) 843-6086
E-mail: scott@zarco66.com

Attendees – 2014 Final Report

Jane Zulkiewicz

Town of Barnstable

200 Main Street

Hyannis, MA 02601

Phone: (505) 862-4773

E-mail: jane.zulkiewicz@town.barnstable.ma.us

Ryan Zydel

Micro Motion Inc.

7070 Winchester Circle

Boulder, CO 80301

Phone: (412) 519-2699

E-mail: ryan.zydel@gmail.com

NIST Technical Publications

Periodical

Journal of Research of the National Institute of Standards and Technology—Reports NIST research and development in metrology and related fields of physical science, engineering, applied mathematics, statistics, biotechnology, and information technology. Papers cover a broad range of subjects, with major emphasis on measurement methodology and the basic technology underlying standardization. Also included from time to time are survey articles on topics closely related to the Institute's technical and scientific programs. Issued six times a year.

Nonperiodicals

Monographs—Major contributions to the technical literature on various subjects related to the Institute's scientific and technical activities.

Handbooks—Recommended codes of engineering and industrial practice (including safety codes) developed in cooperation with interested industries, professional organizations, and regulatory bodies.

Special Publications—Include proceedings of conferences sponsored by NIST, NIST annual reports, and other special publications appropriate to this grouping such as wall charts, pocket cards, and bibliographies.

National Standard Reference Data Series—Provides quantitative data on the physical and chemical properties of materials, compiled from the world's literature and critically evaluated. Developed under a worldwide program coordinated by NIST under the authority of the National Standard Data Act (Public Law 90-396). NOTE: The Journal of Physical and Chemical Reference Data (JPCRD) is published bimonthly for NIST by the American Institute of Physics (AIP). Subscription orders and renewals are available from AIP, P.O. Box 503284, St. Louis, MO 63150-3284.

National Construction Safety Team Act Reports—This series comprises the reports of investigations carried out under Public Law 107-231, the technical cause(s) of the building failure investigated; any technical recommendations for changes to or the establishment of evacuation and emergency response procedures; any recommended specific improvements to building standards, codes, and practices; and recommendations for research and other appropriate actions to help prevent future building failures.

Building Science Series—Disseminates technical information developed at the Institute on building materials, components, systems, and whole structures. The series presents research results, test methods, and performance criteria related to the structural and environmental functions and the durability and safety characteristics of building elements and systems.

Technical Notes—Studies or reports which are complete in themselves but restrictive in their treatment of a subject. Analogous to monographs but not so comprehensive in scope or definitive in treatment of the subject area. Often serve as a vehicle for final reports of work performed at NIST under the sponsorship of other government agencies.

Voluntary Product Standards—Developed under procedures published by the Department of Commerce in Part 10, Title 15, of the Code of Federal Regulations. The standards establish nationally recognized requirements for products, and provide all concerned interests with a basis for common understanding of the characteristics of the products. NIST administers this program in support of the efforts of private-sector standardizing organizations.

Order the following NIST publications—FIPS and NISTIRs—from the National Technical Information Service, Springfield, VA 22161.

Federal Information Processing Standards Publications (FIPS PUB)—Publications in this series collectively constitute the Federal Information Processing Standards Register. The Register serves as the official source of information in the Federal Government regarding standards issued by NIST pursuant to the Federal Property and Administrative Services Act of 1949 as amended, Public Law 89-306 (79 Stat. 1127), and as implemented by Executive Order 11717 (38 FR 12315, dated May 11, 1973) and Part 6 of Title 15 CFR (Code of Federal Regulations).

NIST Interagency or Internal Reports (NISTIR)—The series includes interim or final reports on work performed by NIST for outside sponsors (both government and nongovernment). In general, initial distribution is handled by the sponsor; public distribution is handled by sales through the National Technical Information Service, Springfield, VA 22161, in hard copy, electronic media, or microfiche form. NISTIR's may also report results of NIST projects of transitory or limited interest, including those that will be published subsequently in more comprehensive form.