

Appendix C

NIST Handbook 44 – Liquid-Measuring Devices

Item 330-4:

N.4.2.5. Determination of Error on Wholesale Devices with Multiple Flow Rates and Calibration Factors

How Slow Flow Accuracy Affects LMD's

Because the legal tolerance on slow flow tests is so great (+/-0.5%) compared to industry standards (typically +/-0.05%), and because slow flow tests themselves are so time consuming, registered service agents may be tempted to skip slow flow tests entirely during seasonal re-calibrations. Even if one ignores the fact that the Liquid Measuring Device Code in NIST Handbook 44 requires that a special test be done at the slow flow rate, there remains a very good reason that slow flow rates should always be tested. If the error at the slow flow rate is unknown, then it is impossible to calibrate the high flow rates to deliver with the extreme accuracy sought by industry on quantities which are greater or less than the test prover used at the time of calibration.

Imagine a typical whole sale meter which is calibrated using a 1,000 gallon prover at a terminal where the customers' trucks have pocket sizes between 1,000 and 4,000 gallons. The meter has an electronic register programmed with a slow flow rate for start-up and shut-down, a high-flow rate for typical deliveries, and a mid-speed fallback rate for when the pumps can't keep up with demand. Startup and shutdown deliveries are 100 gallons each regardless of total quantity delivered.

Now imagine that the service agent calibrating the meter didn't check the slow flow rate and didn't know that the meter was short five gallons on a one thousand gallon test. Instead, he calibrated the fallback and normal flow rates without testing the slow flow and introduced a linear error which increases the farther the transaction quantity deviates from the prover size. On a 1,000 gallon delivery the meter would appear to be accurate, but on a 3,400 gallon delivery a three gallon error has been introduced. That is a 0.09% error which is almost twice the typical industry goal.

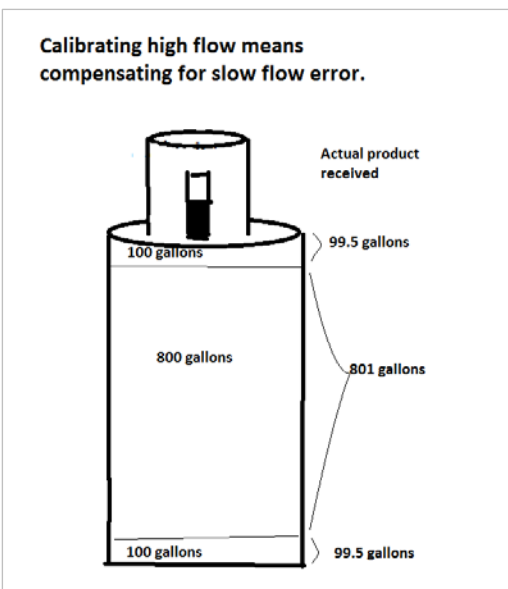

When calibrating at the normal and fallback speeds, the meter registers 200 gallons of product for the startup and shutdown, but actually delivers only 199 gallons. (99.5 gallons delivered for every 100 gallons registered at slow speed.) If the service technician calibrates the meter to zero at normal and fallback rates, the meter will actually deliver 801 gallons for every 800 gallons it registers at those rates.

Every subsequent delivery of 1000 gallons should receive exactly the right amount. Every delivery exceeding 1000 gallons will be 'long' and every delivery less than 1000 gallons will be short.

To determine the error on a typical delivery, the service agent needs to calculate the error introduced by the startup and shutdown gallons, and then the error introduced at the higher flow rates.

For a 3,400 gallon delivery in this example, the meter would register 100 gallons on startup but only deliver 99.5 gallons. It would then jump to normal rate and deliver 801 gallons for every 800 gallons it registers until it goes into shutdown mode when it slows down and again delivers only 99.5 gallons of the 100 gallons it registers. Delivery error is +3 gallons (0.09%).

EXAMPLE SLOW FLOW IS 5G/1000G SHORT AND HIGH FLOW WAS ADJUSTED AS A RESULT.

Driver ordered 3400 gallons for pocket 2.

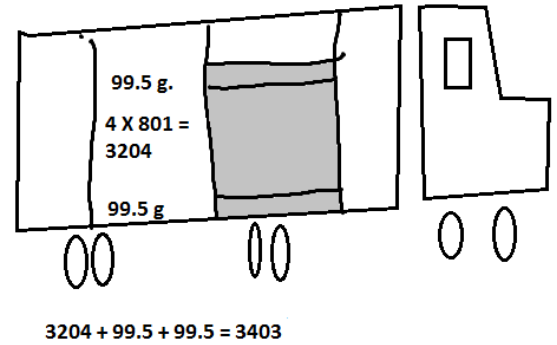

EXAMPLE WHEN SLOW FLOW RATE IS 5G/1000G LONG AND HIGH FLOW WAS ADJUSTED AS A RESULT.

Driver ordered 3400 gallons for pocket 2.

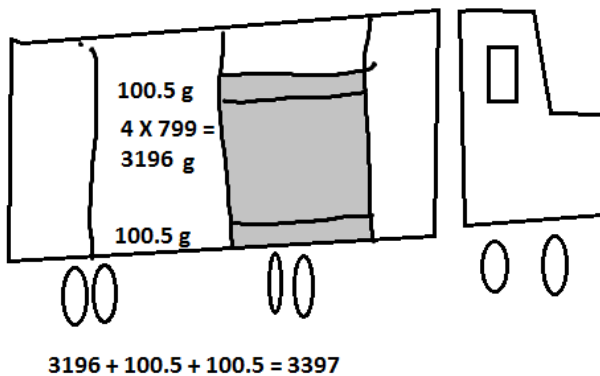

The math would be reversed if the meter had been five gallons long on a 1,000 gallon slow flow test at the startup and shutdown speed. The meter would deliver 100.5 gallons for every 100 gallons it registered at startup and shutdown, but only 799 gallons for every 800 gallons registered at the normal delivery rate. The total delivery is 3 gallons (0.09%) short. Under-registration, which is favorable to consumers in most situations, can be detrimental to them when it occurs at the slow flow speed.

Does it matter considering that the error introduced is so much smaller than the tolerance allowed in the liquid measuring code? It does to industry, or they wouldn't set such tight accuracy standards for themselves. And it does to Weights & Measures officials who must consider the predominant direction of error in addition to tolerance. Everyone's time is wasted chasing extreme accuracy at the normal delivery rate if the accuracy of the startup and shutdown rate has been ignored.