

National Institute of Standards and Technology DoC Boulder Laboratories Campus

U. S. DEPARTMENT OF COMMERCE
BOULDER LABORATORIES
325 BROADWAY

Signage and Wayfinding Design Standards and Guidelines



NIST

Updated May 2022

July 2021

Metropolitan Architects and Planners, Inc.

Table of Contents

Executive Summary	1
Campus Context	1
Signage and Wayfinding Program	2
Using these Guidelines	3
Design Standards for Sign Elements	4
Color Palette.....	4
Typeface	5
Logos, Identifiers, Icons, and Arrows	6
Design Standards for Exterior Signs	7
DOC Boulder Laboratories Campus – Site Plan.....	8
Site Identification – Secondary Gate	10
Primary Directional Signage	14
Building Identification	18
Parking Lot Identification and Directional	21
GSA Regulatory Sign.....	24
Pedestrian Directional and Regulatory Sign	27
Security Center Directional Sign	31
Design Standards for Interior Signs	33
Overhead Directional Signage	33
Overhead Identification Signage	36
Wall-Mounted Directional Signage.....	38
Wall-Mounted Room and Door Identification Signage	41
Wall-Mounted Emergency Signage.....	46
Fabrication and Installation Guidelines.....	49
Appendix:	
Boulder Campus Building Names and Numbers	
Message Schedule for Exterior Signs	
Message Schedule for Interior Signs	

Executive Summary

The Department of Commerce (DOC) Boulder Laboratories campus is set against the backdrop of central Colorado's Flatirons and Kohler Mesa. The 206-acre site is home to research programs of the National Institute of Standards and Technology (NIST), the National Oceanic and Atmospheric Administration (NOAA) and the National Telecommunications and Information Administration (NTIA). Close to 2,000 research, scientific and support professionals conduct their work in more than 30 buildings.

This document was developed in concert with Office of Facilities and Property Management (OFPM) staff in Boulder and Gaithersburg as well as the Boulder Operations Group, a campus-wide consortium of stakeholders. It establishes design standards for exterior identification and wayfinding signage for the entire campus, interior identification signage for all NIST controlled buildings, and interior wayfinding signage for the central spine of Building 1.

The exterior wayfinding effort is significant not only because multiple DOC components share the campus, but this picturesque campus is open to public bicycle and foot traffic. Currently there are few exterior directional signs and only sporadic building identification signs on the property. NIST proposes to remedy the situation with a coordinated and consistent signage program that provides identification and directional signs for vehicular traffic, pedestrians,

and cyclists. Following the standards and guidelines established for NIST's Gaithersburg, Maryland campus, the exterior signage for Boulder will be clean, modern, and most importantly, informational.

The majority of NIST's personnel and almost all of NTIA personnel work in Building 1 which was constructed in the 1950's. Known historically as the Radio Building, Building 1 has a central spine and six wings and is built on a slope. From the main entrance on the east end of the complex, the spine steps up to the southwest. Considering all levels, the ground floor in wings 5 and 6 (at the southwest end) are essentially the fourth level of Building 1 (the basement near the entrance to Building 1 being the lowest level) with much potential for confusion. This document provides a comprehensive wayfinding program to guide personnel along the spine, helping users to navigate the corridors and wings of this large facility.

Campus Context

A primary challenge of the wayfinding and signage program is guiding people around a geographically large campus with more than 30 buildings and multiple parking lots.

Daily users include federal employees (researchers, administrators, and support staff), contract employees, student interns and guest researchers.

Intermittent users include visitors, conference attendees, construction, and service workers. Each group has different building access restrictions and needs to understand where they may drive, park, and walk.

Additionally, the general public has open access to the many trails running through the campus. These recreational users have several access points to the campus, via the trails, and may be walkers, runners, and cyclists.

For those entering the campus in vehicles, the entrance at Rayleigh Road and Broadway is the single point of access. There are two other vehicular entrances that are intended for use by emergency vehicles or are utilized under other special circumstances. Users may also arrive on foot, by bicycle or via public transportation.

The Security Center, Building 51, handles visitor and vehicular screening functions and is located at the main entrance on Rayleigh Road. It will continue serving these functions with some modifications as the 2017 Master Plan is implemented.

The exterior wayfinding signage in this document identifies major buildings, roads, and parking areas and will direct users around the campus. For overall graphical and branding consistency, signage standards and guidelines for the

NIST Gaithersburg campus have been adapted with some modifications to address contextual considerations.

The functional objectives addressed in the Design Standards and Guidelines include:

- **Visibility**—Ensure visibility for all campus user modes of travel (vehicles, pedestrians, and bicyclists) through size, location, and orientation. Eliminate obstructions.
- **Consistency**—Create uniformity through a hierarchy of typography, color, messages, and materials.
- **Clarity**—Reduce overload and clutter to create order and simplicity.
- **Accessibility**—Accommodate diverse user groups.

Signage and Wayfinding Program

The design team considered the campus-wide circulation system in developing the guidelines. This document outlines recommendations for campus-wide wayfinding and identification: identification at the secondary entrance gates; direction on the campus roads; necessary information to users entering and exiting parking lots; and, identification of buildings. For the spine of Building 1, identification and

wayfinding signage recommendations have been provided.

Basic design standards include:

- Concepts and directives developed by NIST architectural staff and the members of Boulder Operations Group from Summer 2020 to Spring 2021.
- Standard type on all messages is generally flush left, ragged right (rather than centered or justified), a standard for typesetting developed in the 1960s and considered modern (then and now). This will help make the visual appearance of signs consistent across the two campuses.
- Materials incorporate “white” metals (silver-colored aluminum, steel, etc.), concrete bases and etched or printed letters and numbers.
- “NIST Blue” is used as an accent on signs. It is a standard established on NIST’s website and other publications.
- The NIST Logo and Identifier are used in a consistent manner.

Exceptions

The signage provider may request NIST for exceptions from these standards and guidelines if there are exceptional circumstances. These exceptions may cover suggested materials as well as design elements. These requested exceptions must be reviewed and approved by the NIST Contracting Officer's Representative (COR) on a case-by-case basis.

Signage Design

A range of signs within a specific design framework has been developed. The signage program follows these rules:

- Signs are composed of layered metal panels in two colors— NIST blue, plus aluminum or aluminum-colored material.
- The amount of blue predominates on large signs and reduces to a branding accent on medium-sized signs. Smaller signs, such as door plaques and flag signs, have no blue, meant to allow them to blend with the building interiors.
- 2-sided signs have blue cores; 1-sided signs have blue back panels.
- Sign messages in white on blue panels favor permanent, non-changeable information, including directions.

- Sign messages in black on aluminum panels favor changeable messages and allow those panels to be replaced without re-manufacturing entire signs.
- All signs must comply with the minimum requirements of the most current Architectural Barriers Act (ABA) Standards and the Americans with Disabilities (ADA) Act. To the extent possible, the designs shall also meet the minimum requirements of the most current Uniform Federal Accessibility Standards (UFAS). If there are conflicts with the provisions of this document and the minimum requirements of the ABA, ADA and UFAS, the NIST COR will review such conflicts and provide guidance.
- Braille shall comply with 703.3 and 703.4 of the Architectural Barriers Act (ABA) Standards. The braille shown in some of the sign illustrations in the following pages are not to scale; in all instances, ABA Standards for braille shall prevail.
- Raised characters shall comply with section 703.2 of the Architectural Barriers Act (ABA) Standards. In particular, such characters must be 1/32" above their background, and 5/8" to 2" tall in height.

Using these Guidelines

The intent of the guidelines is to provide representative drawings of various sign types that include dimensions, panel configurations and sample messages. These guidelines also convey the following to the vendors/ sign manufacturers:

- Design standards for sign elements—components of the signs such as color, typeface;
- Design standards for exterior signs—designs/drawings for site identification, building identification and directional signs;
- Design standards for interior signs—designs/drawings for room identification and directional signs; and
- Fabrication and installation guidelines—requirements for the signage providers.

Design Standards for Sign Elements

Color Palette

NIST Blue aluminum, natural anodized aluminum, and cast-in-place concrete are the primary colors and materials to be used for all signs.

Fabricator to supply pricing and samples of powder coated aluminum, porcelain enamel, other recommended finishes.



rgb: 18, 101, 156
cmyk: 92, 60, 15, 2
Benjamin Moore 2065-30
Brilliant Blue

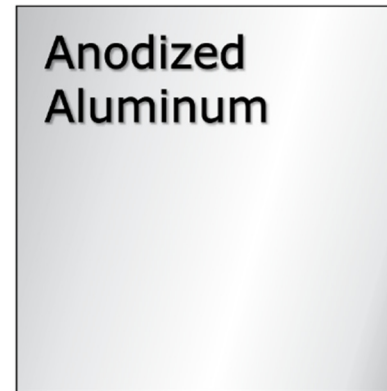

Natural anodized aluminum



Precast or cast-in-place

Typeface

1950s typeface DIN was originally designed for technical uses and has same-width numerals, allowing 2-digit building numerals to align vertically as shown in example below.

22
33
81
92

NOTES:

Sign Vendor/Manufacturer is responsible for procuring these fonts.

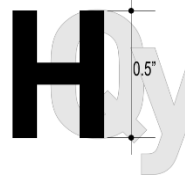

Dimensions shown on drawings for letters and numerals, including size and position, are based on the height of a capital letter H.

DIN Regular

abcdefghijklmnopqrstuvwxy
 ABCDEFGHIJKLMNOPQRSTUVWXYZ
 0123456789

DIN Medium

abcdefghijklmnopqrstuvwxy
 ABCDEFGHIJKLMNOPQRSTUVWXYZ
 0123456789

DIN Bold

abcdefghijklmnopqrstuvwxy
 ABCDEFGHIJKLMNOPQRSTUVWXYZ
 0123456789

DIN Black

abcdefghijklmnopqrstuvwxy
 ABCDEFGHIJKLMNOPQRSTUVWXYZ
 0123456789

Logos, Identifiers, Icons and Arrows

NIST

NIST logo, designed in 1988, to be used throughout, as required, per current guidelines from NIST Public Affairs.

NIST

National Institute of Standards and Technology
U.S. Department of Commerce

NIST identifier, composed of NIST logo and supplemental type, to be used throughout, as required, per current guidelines from NIST Public Affairs.

NOTE: Digital files of official DOC-approved logos, identifiers, pictograms, icons, and arrows will be provided to NIST sign fabrication vendors.

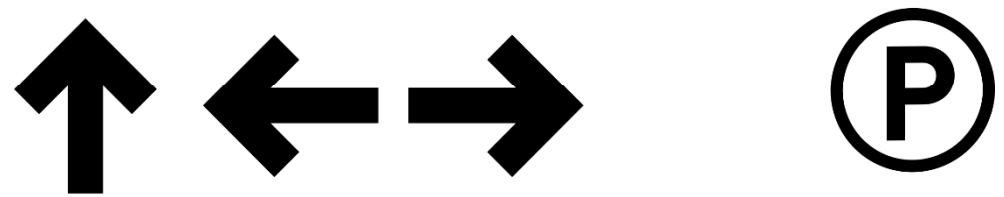

H

Arrow stem equals width of DIN Bold typeface capital (upper case) letter "H" vertical stroke.

Design Standards for Exterior Signs

Campus Identification

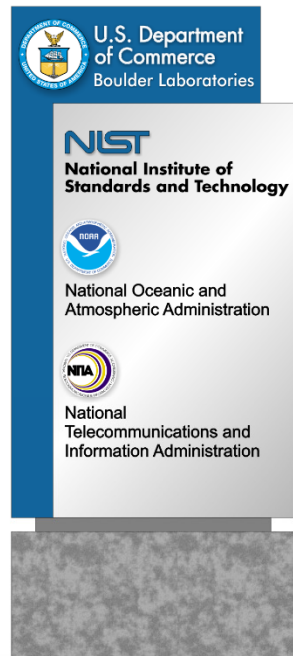

Primary Directional

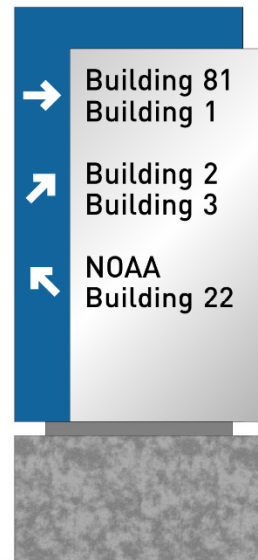

Building Identification

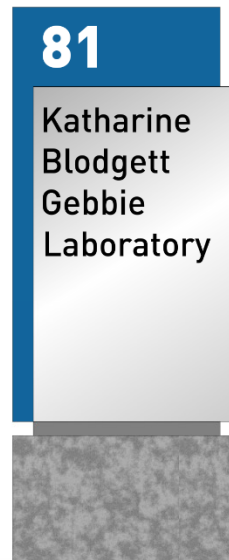

Parking Lot Identification and Directional

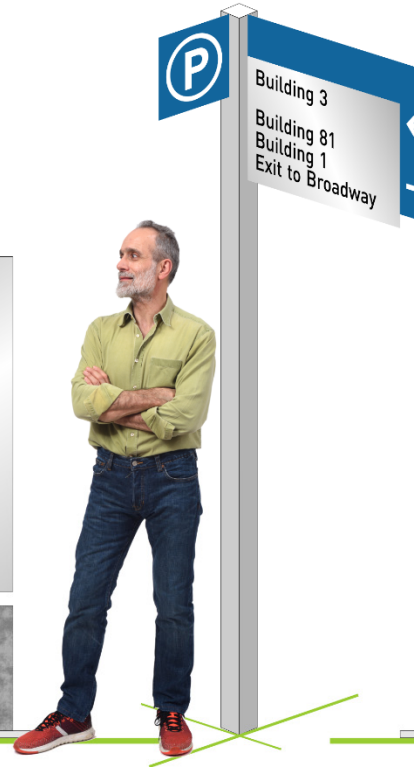

Regulatory



Pedestrian

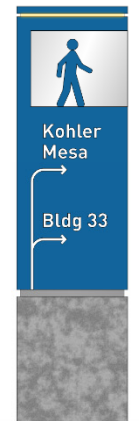

Department of Commerce Boulder Laboratories Campus – Site Plan

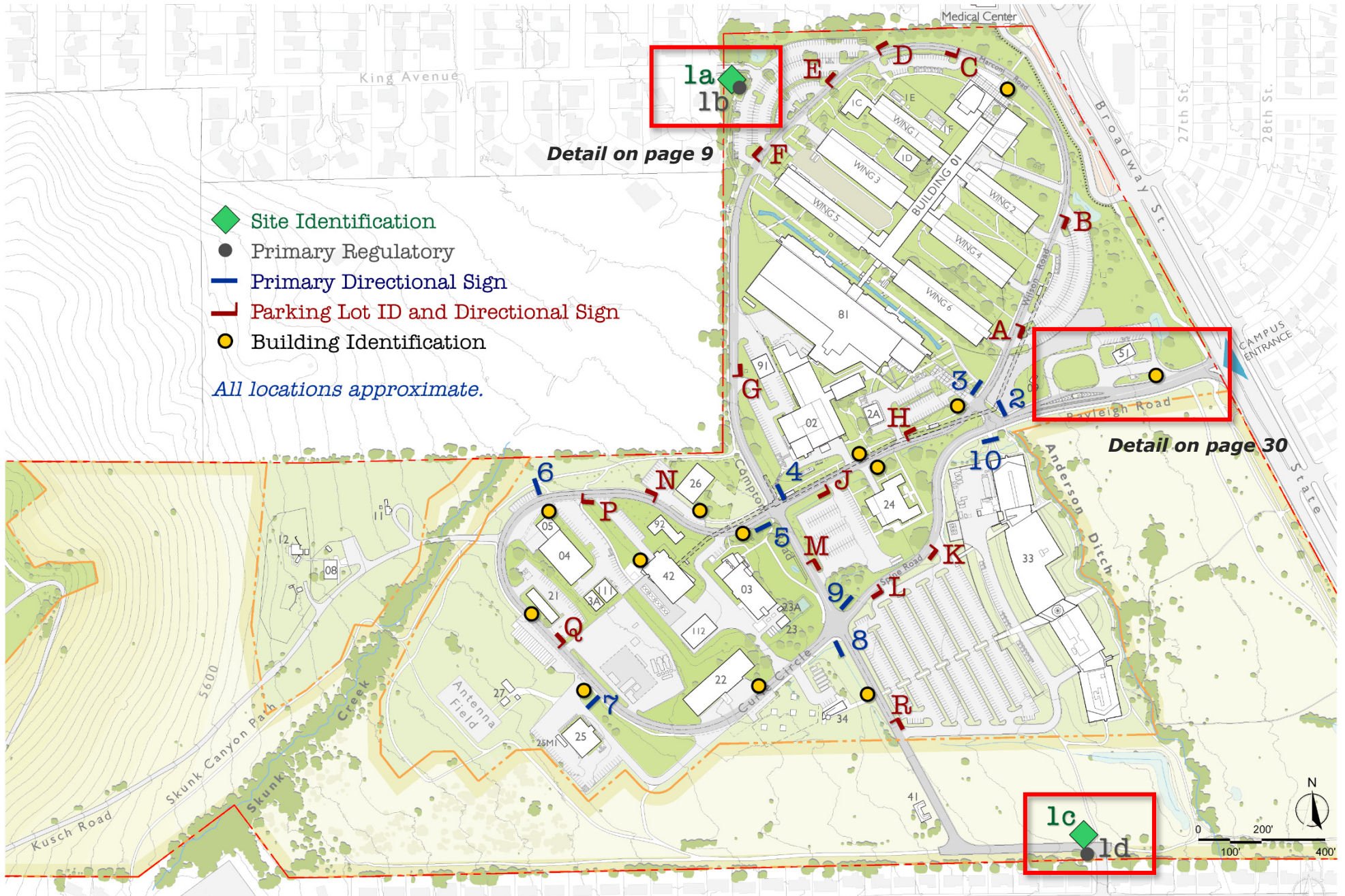

Detail on page 9

Detail on page 30

Detail on page 9

Location of Gate and Regulatory Signs

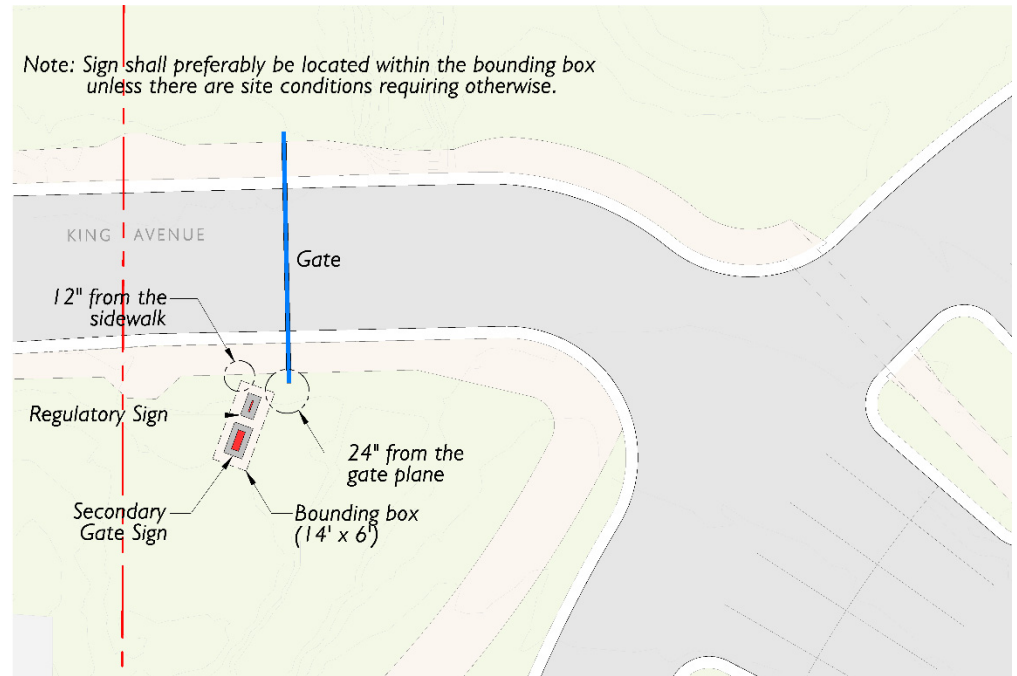

King Avenue Entrance (1a and 1b)

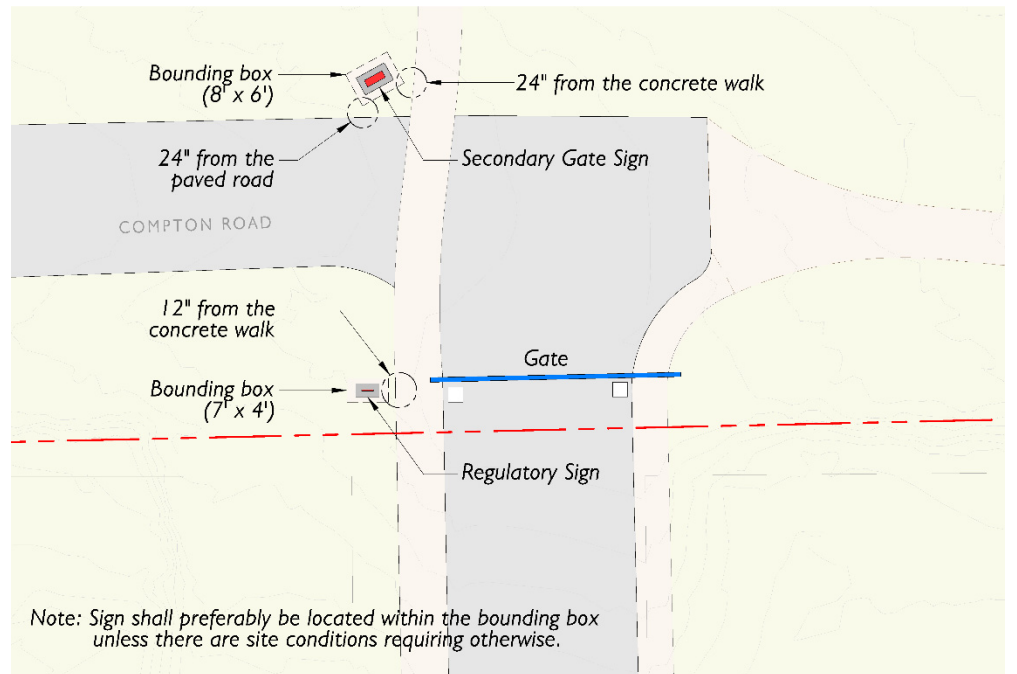

Compton Road Entrance (1c and 1d)

Site Identification – Secondary Gate

Base

Poured in place concrete.

Main sign structure

Fabricated aluminum, NIST Blue.

Panel 1

DOC identifier message panel:
fabricated anodized aluminum
mechanically fastened to main structure.

Panel 2

Organizations panel: 2 fabricated
anodized aluminum panels mechanically
fastened to panel 1 with spacers. Front
and back message panels align left to
right.

Messages

DOC Seal fabricated aluminum
mechanically attached to panel 1. DOC
Identifier and “Boulder Laboratories” are
fabricated dimensional letters
mechanically fastened to panel 1.
NIST logo, NOAA seal, and NTIA seal will
be fabricated and mechanically fastened
to the panel. Identifiers/organization
names are to be etched into the panels
and paint-infilled black.
NIST, NOAA and NTIA official artwork to
be provided.

Typefaces

“Boulder Laboratories” DIN Medium.



Site Identification – Secondary Gate

Campus entrances at King Avenue and Kenwood Drive

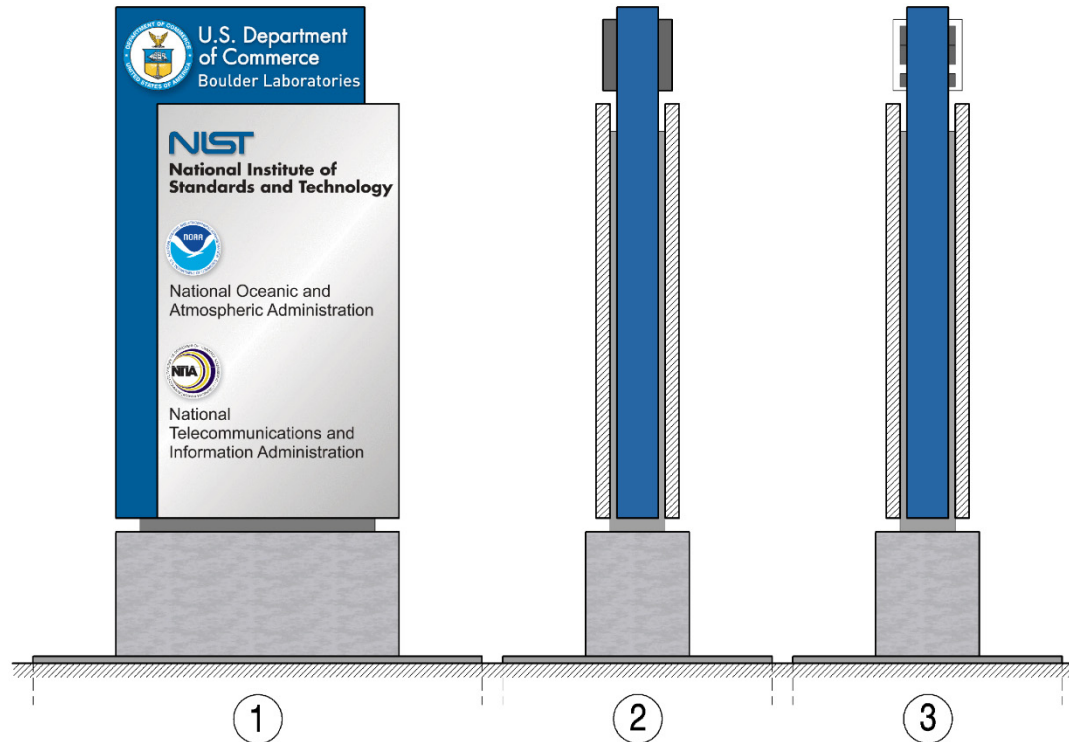
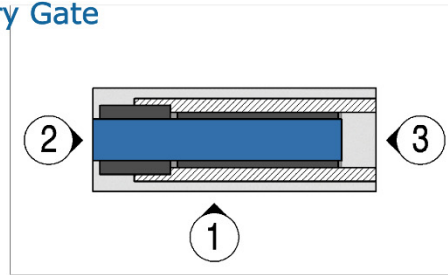

Signs are composed of one back panel and two message panels mechanically fastened to a concrete base with a 2" reveal.

Signs to be oriented for maximum visibility from street.

Text aligns left.

Back Panel

One 74" high, 36" wide, 6" deep fabricated aluminum panel, NIST blue on all visible sides.

DOC Seal and letters to be mechanically attached to back panel on both sides.

Message Panels

Two 60" high, 35" wide, 2" deep fabricated anodized aluminum panels.

NIST logo and NOAA and NTIA seals mechanically attached to panels.

Organization names are to be etched into panels and paint-infilled black.

Base

18" high, 41" wide, 15" deep poured-in-place concrete (see structural notes on page 45). A concrete mowing strip extends 12" out on all sides.

Reveal

2" high, 34" wide and 8" deep aluminum reinforced pan, gray on all visible sides.

Site Identification – Secondary Gate

Campus entrances at King Avenue and Kenwood Drive
Dimensions

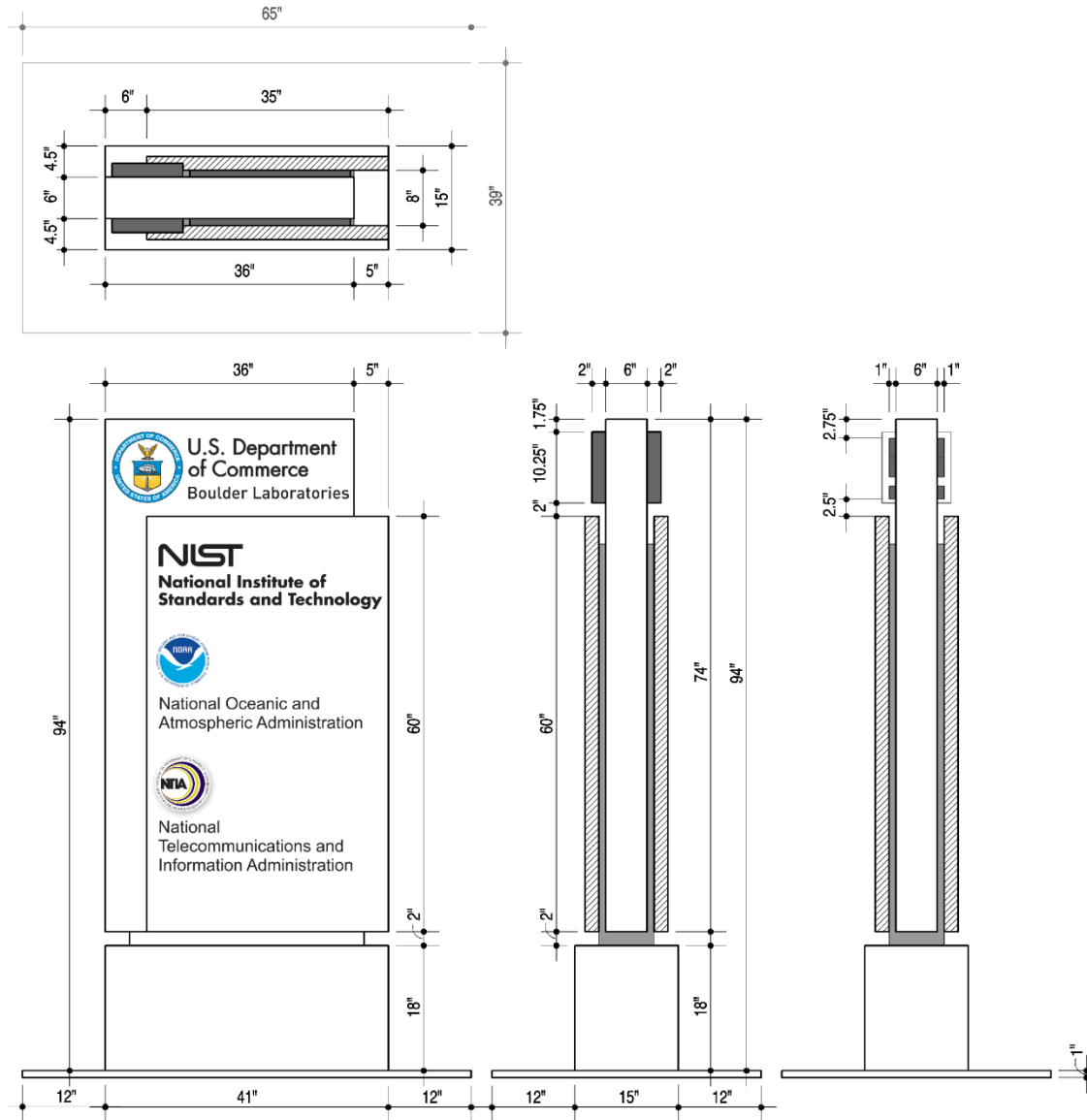

Site Identification – Secondary Gate

Campus entrances at King Avenue and Kenwood Drive
 Dimensions, continued

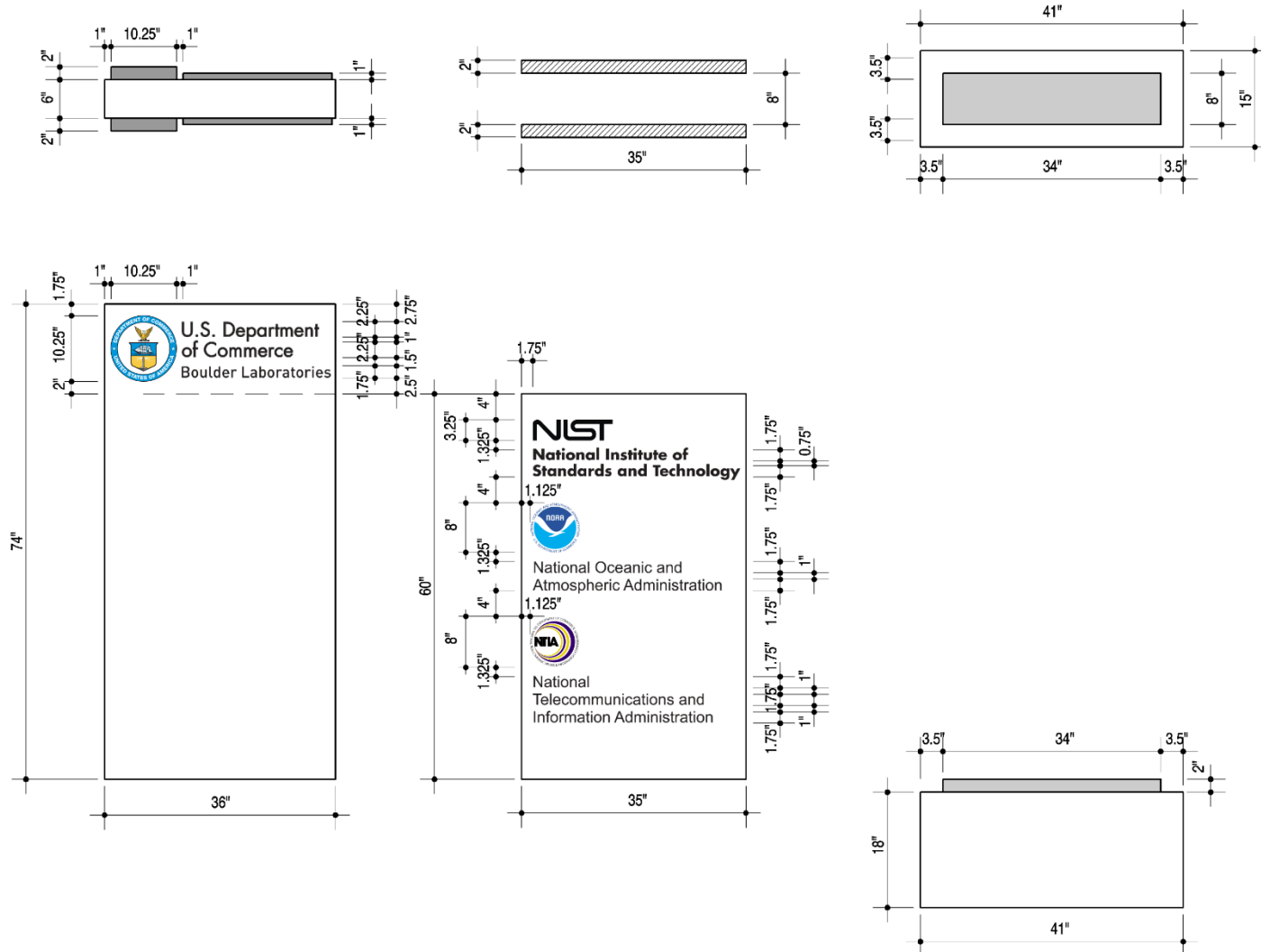

Primary Directional Signage

Messages

Maximum three directions, 2 destinations each, 6 total.

Back panel: Arrows.

Front panel: Building names and number

Typefaces

Building names: DIN Medium.

Arrow

From provided art.



Primary Directional Signage

Major Intersections/
Decision Points

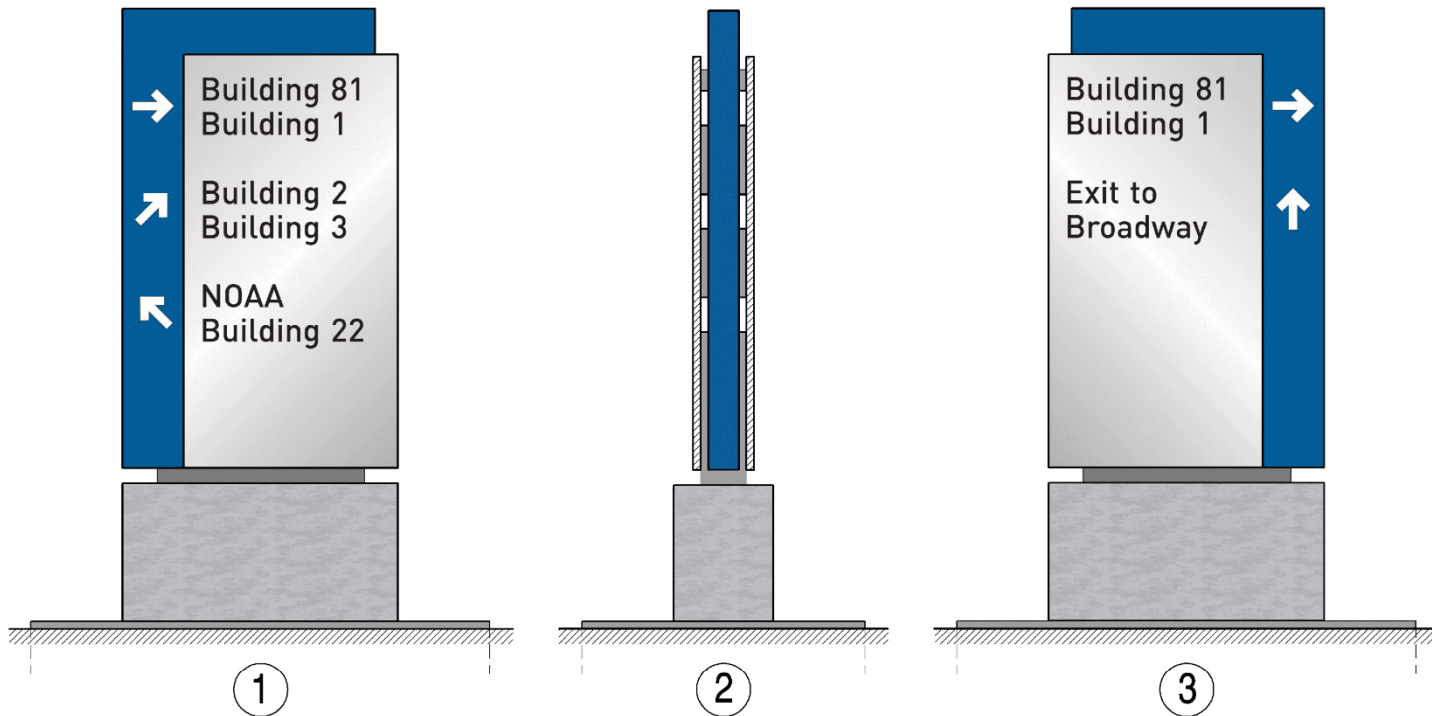
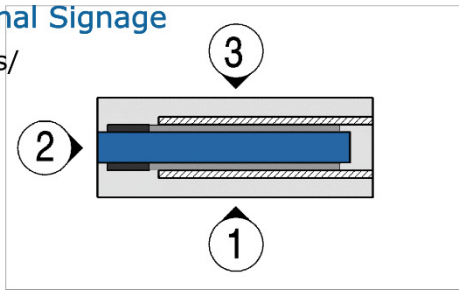

Signs are composed of one back panel and two message panels mechanically fastened to a concrete base with a 2" reveal.

Signs installed perpendicular to street unless other contextual reasons require reconfiguring.

Text aligns left.

Back Panel

One 60" high, 33" wide, 4" deep fabricated aluminum panel, NIST blue on all visible sides.

Anodized aluminum arrows are 5.5" wide (measured with arrow pointing left or right) and 4.5" tall, attached mechanically to back panel.

Message Panels

Two 54" high, 28" wide, 1" deep fabricated anodized aluminum panels. 3" cap height letters etched into panels and paint-infilled black.

Mechanically fastened to back panel.

Base

18" high, 36" wide, 13" deep poured-in-place concrete (see structural notes on page 45). A concrete mowing strip extends 12" out on all sides.

Reveal

2" high, 27" wide and 6" deep aluminum reinforced pan, gray on all visible sides.

Primary Directional Signage

Major Intersections/Decision Points
Dimensions

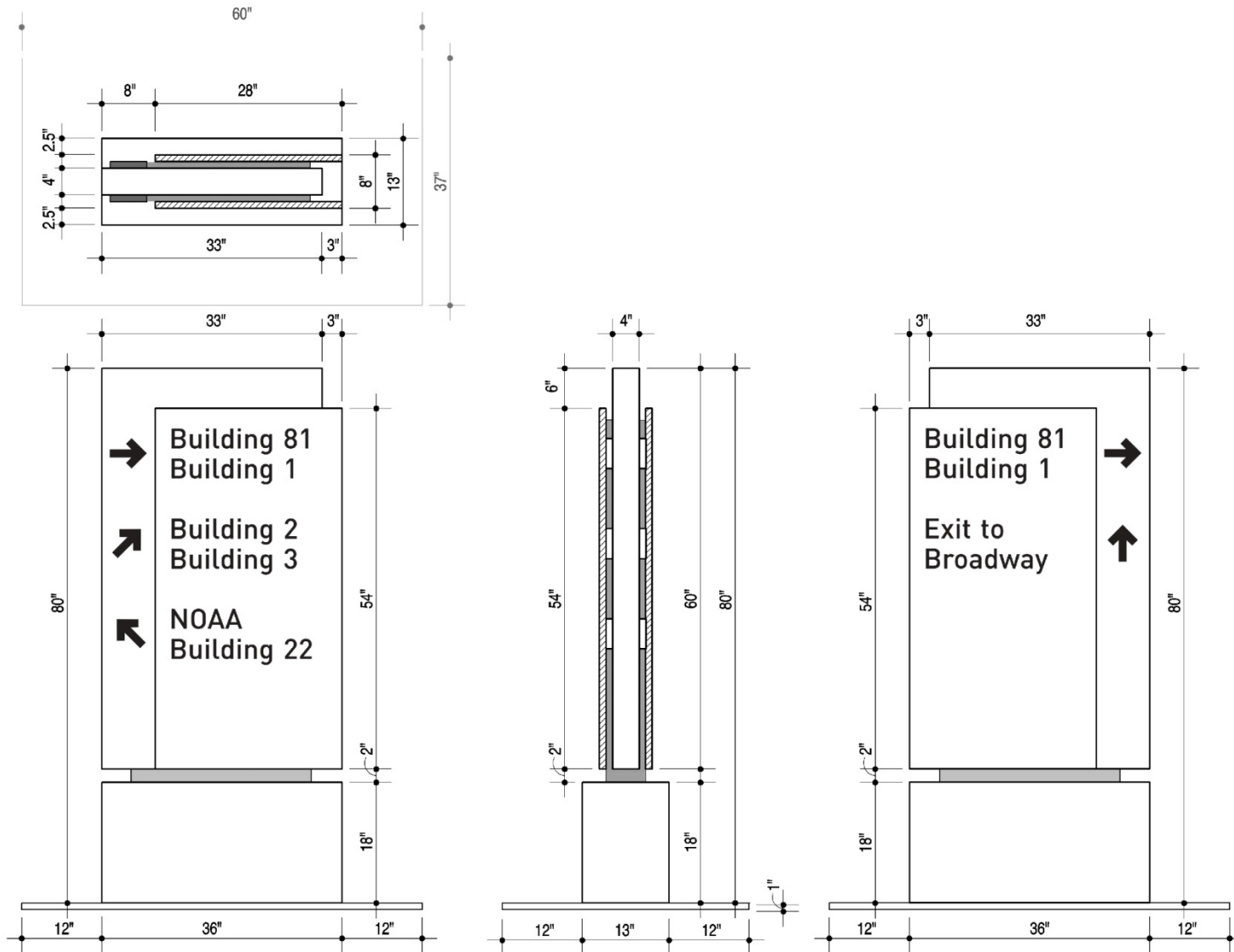

Primary Directional Signage

Major Intersections/Decision Points
Dimensions, continued

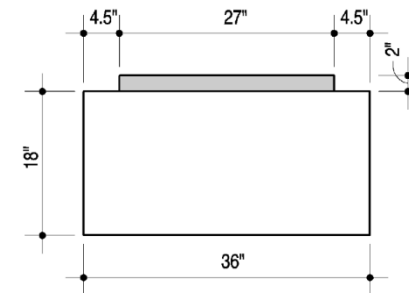
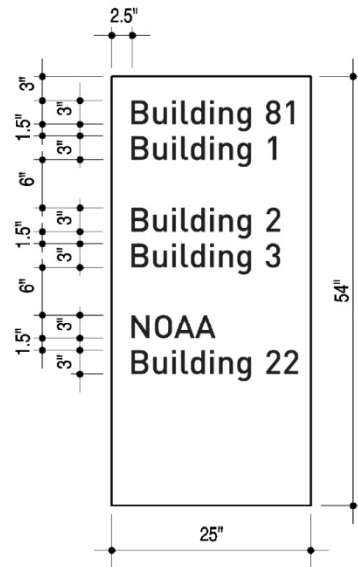
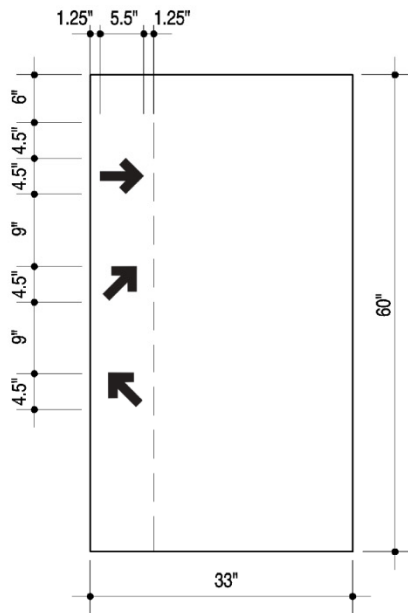
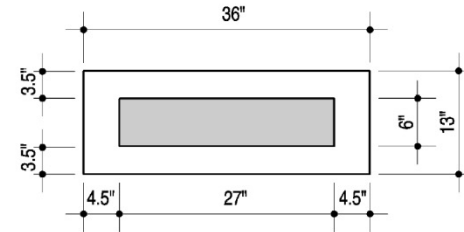
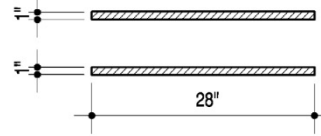
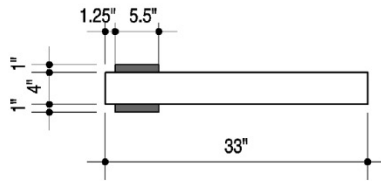

Building Identification

Panels

Two-sided.

Messages

Back panel: building numeral.
Front panel: full building name.

Typefaces

Building numerals: DIN Black.
Building names: DIN Medium.



Building Identification

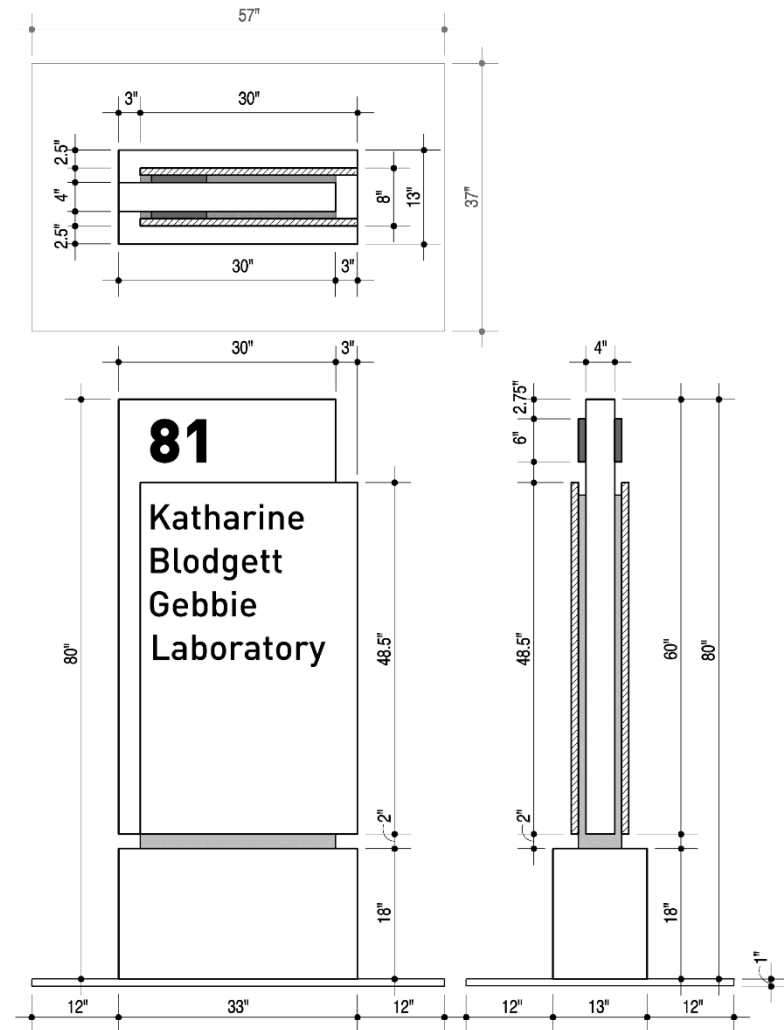
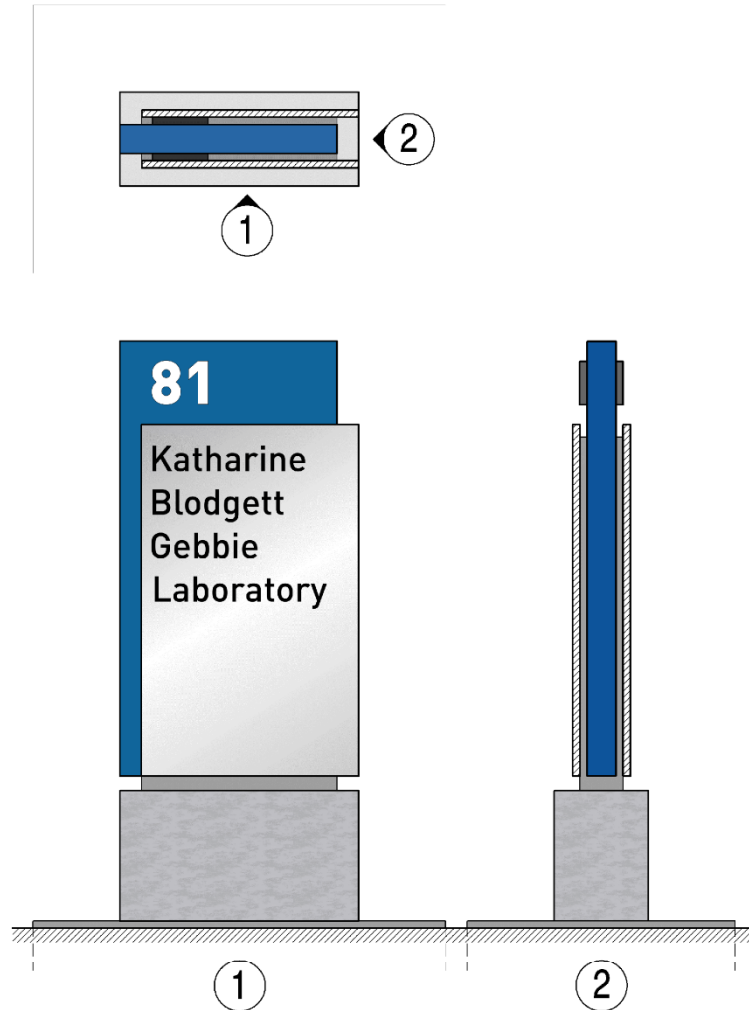

Signs are composed of one back panel and two message panels mechanically fastened to a concrete base with a 2" reveal.

Signs installed perpendicular to street. Text aligns left.

Back Panel

One 60" high, 30" wide, 4" deep fabricated aluminum panel, NIST blue on all visible sides.

Anodized aluminum numbers are 6" high and 1" thick, adhered to both sides of back panel.

Message Panels

Two 48.5" high, 30" wide, 1" deep fabricated anodized aluminum panels. 3.5" cap height letters etched into panels and paint-infilled black.

Mechanically fastened to back panel with 1" spacers.

Base

18" high, 33" wide, 13" deep poured-in-place concrete (see structural notes on page 45). A concrete mowing strip extends 12" out on all sides.

Reveal

2" high, 27" wide and 6" deep aluminum reinforced pan, gray on all visible sides.

Building Identification

Dimensions

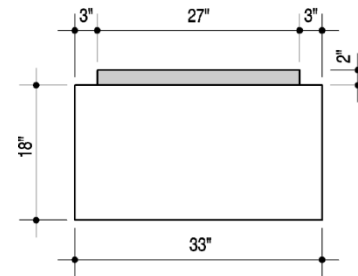
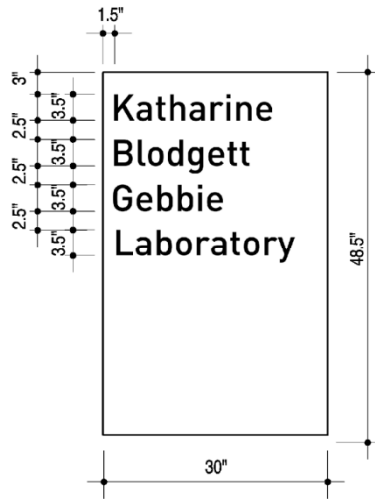
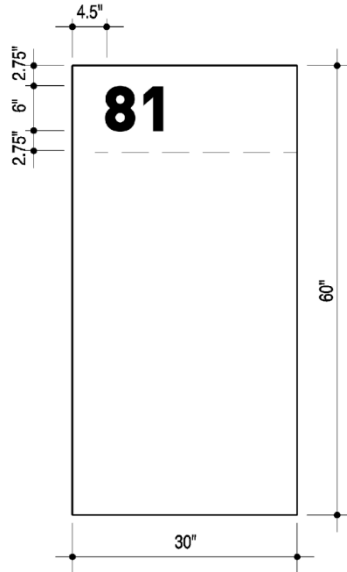
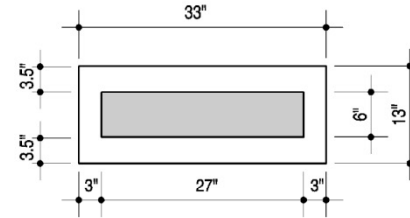
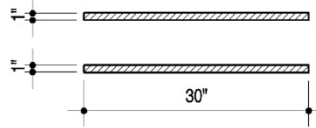
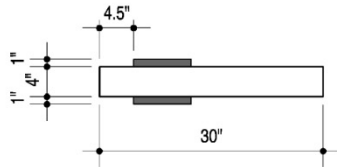

Parking Lot Identification and Directional

Directional

Panels

Two-sided.

Messages

No more than four destinations and two arrows per panel.

Back panel: arrow, Street name on parking lot side.

Front panel: Building numbers and names, other directional messages.

Typefaces

Street Name: DIN Medium.

Building name, numerals,

destinations: DIN Medium.

Arrow from provided art.

Parking ID Flag

Panels

Two-sided

Messages

Parking Icon.

Typefaces

Parking icon from provided art.

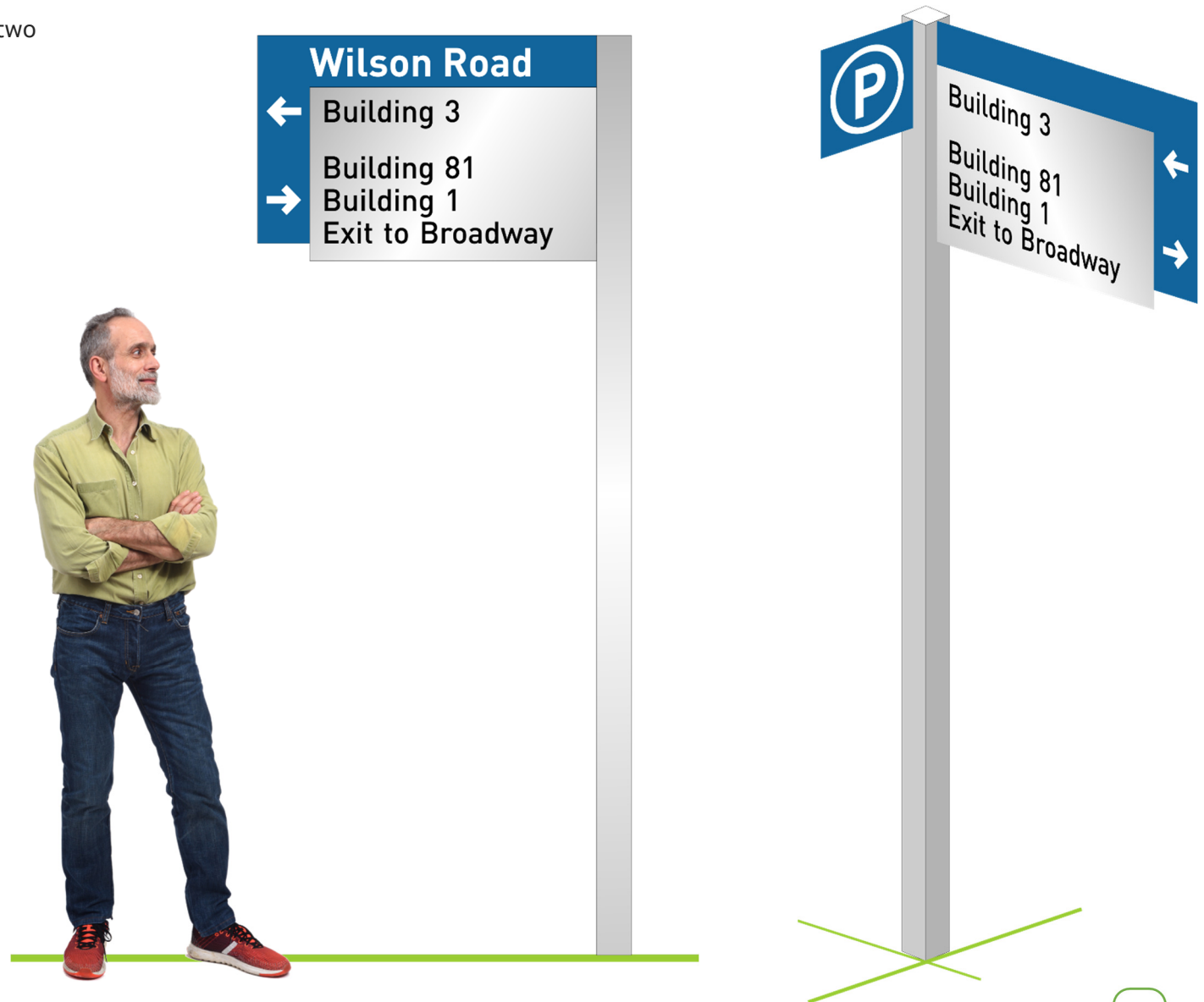

Parking Lot Identification and Directional

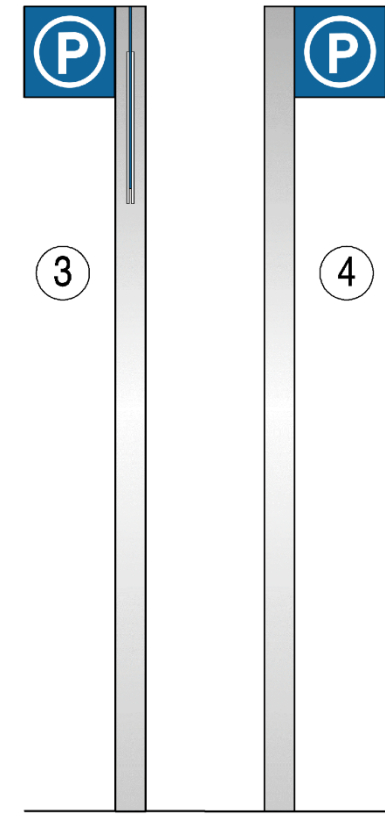
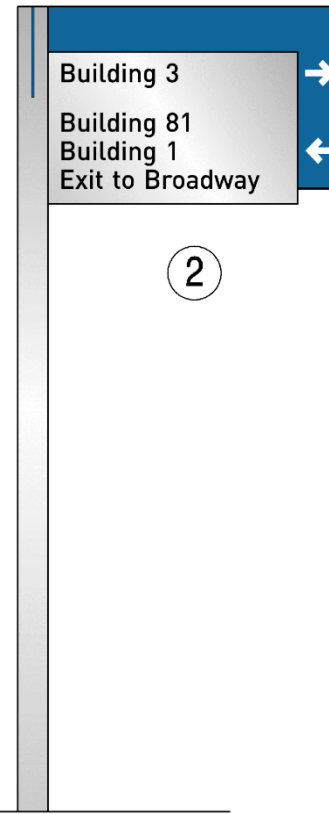
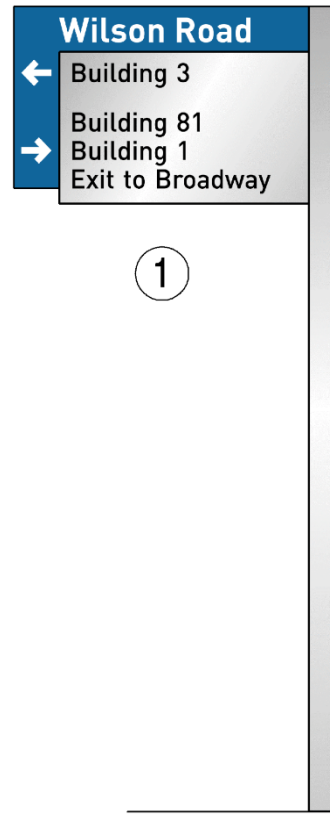
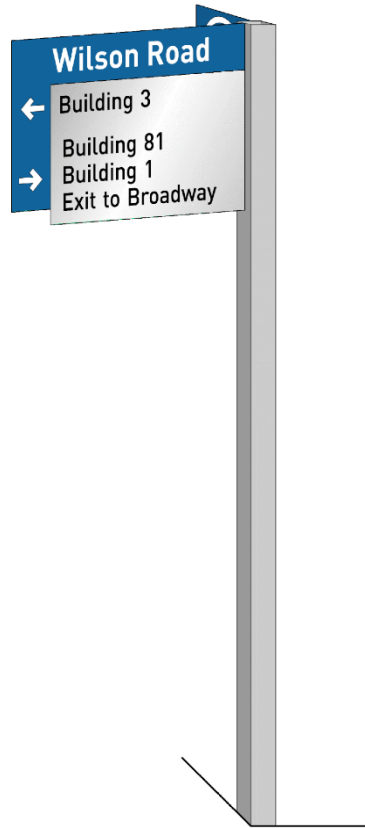
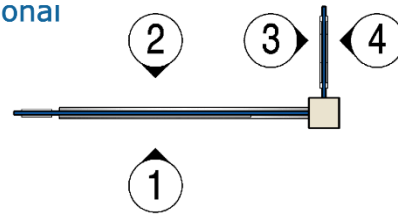

One flag panel and a back panel with two message panels perpendicularly fastened to a 106" tall, 4" square metal post set into concrete footer (see structural notes on page 45), fastening mechanism determined by fabricator. Text aligns left.

Parking Flag is perpendicular to street, directional side is parallel.

Back Panel

1/4" fabricated aluminum, NIST blue on all visible sides, 24" high, 39" wide.

Arrows and letters are anodized aluminum. 3.25" cap height letters on parking lot side. Arrows on both sides are 4" wide (measured with arrow point left or right) and 3.5" high.

Message Panels

Two 20" high, 33" wide, 1/4" thick fabricated anodized aluminum panels.

2.5" cap height letters etched into panels and paint-infilled black.

Mechanically fastened flush to back panel.

Flag Panels

12" square, 1/4" thick fabricated aluminum, NIST blue.

Circled P is 9.5" diameter, centered on panel, etched and in-fill painted white on both sides.

Parking Lot Identification and Directional Dimensions

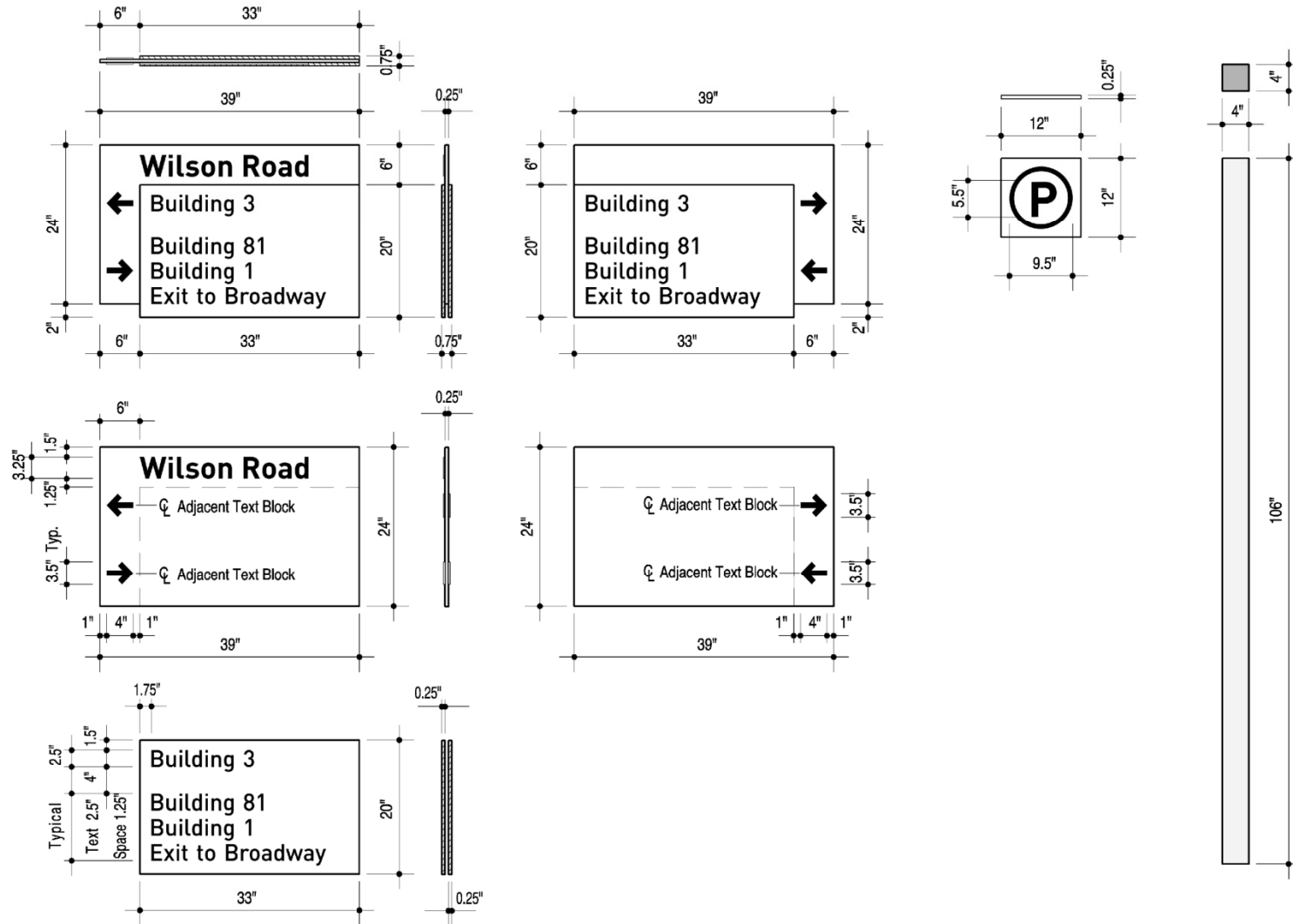

GSA Regulatory Sign

Panels

One or two-sided, as needed, depending on location.

Messages

Federal regulations for site, as needed.

Typefaces

DIN Black and DIN Medium.

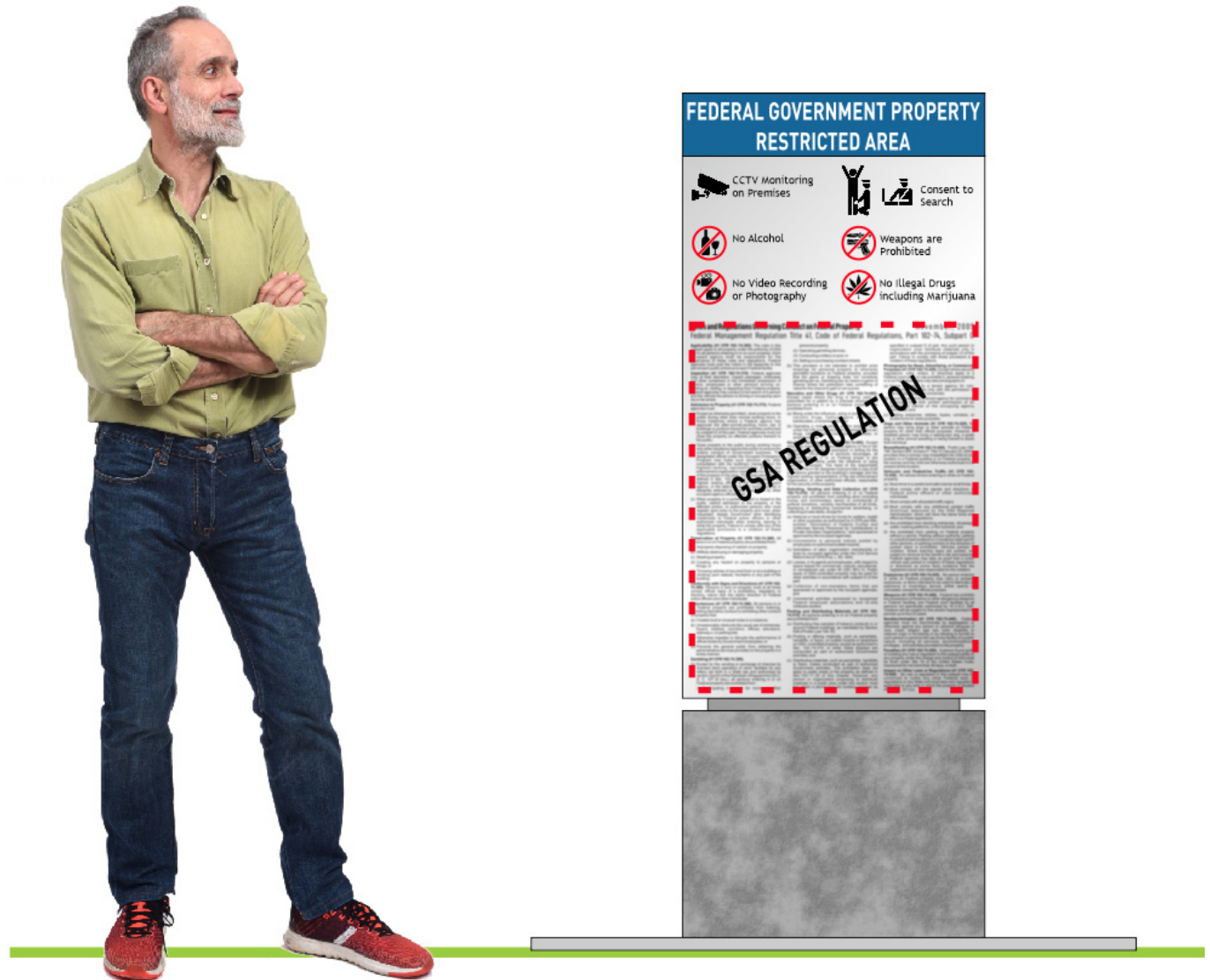

GSA Regulatory Sign

Dimensions

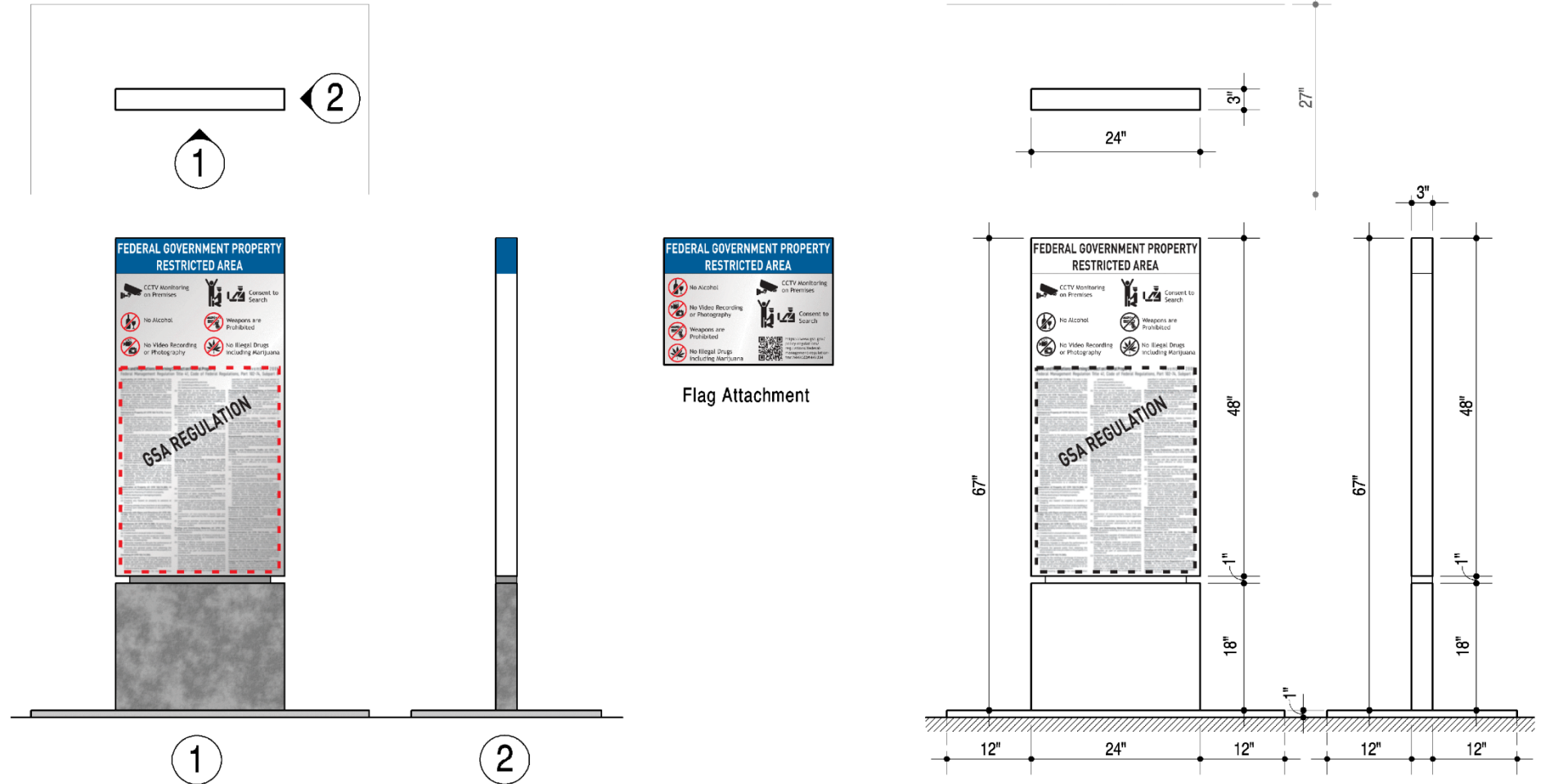

Sign is composed of one fabricated aluminum panel mechanically fastened to a concrete base with a 1" reveal.
Text aligns left.

Panel
One 48" high, 24" wide, 3" thick fabricated aluminum panel, top 5" painted NIST blue on all visible sides.

Messages
Letters in blue portion are 1.5" high caps etched and paint-infilled white.
Lower portion is direct digital print in black and red. Upper area has .625" high lettering. Lower area, the GSA regulatory language, will be scaled to fit in roughly 22.5" wide by 29" high area.

Base
18" high, 24" wide and 3" thick cast-in-place concrete (see structural notes on page 45) atop a 1" high mowing strip extending 12" on all sides.

Reveal
3" thick, 20" wide by 1" high fabricated aluminum pan, grey on all sides.

Flag Attachment
One 18" high, 24" wide, 1/4" thick fabricated aluminum panel, top 5" painted NIST blue on all visible sides.
1.5" cap letter height on top, etched and white painted infill.
Lower portion has .625" high letters, direct digital printed in black and red.

GSA Regulatory Sign

Dimensions, continued

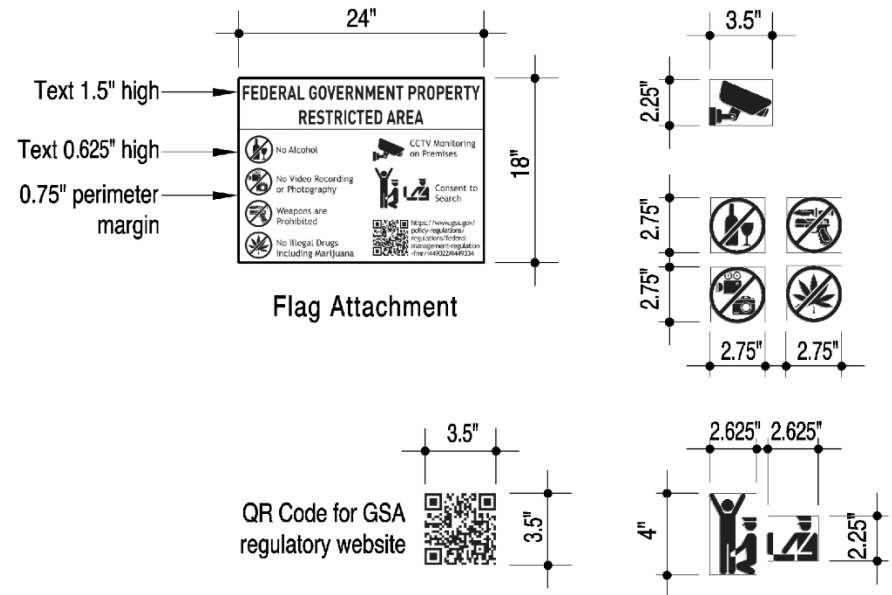
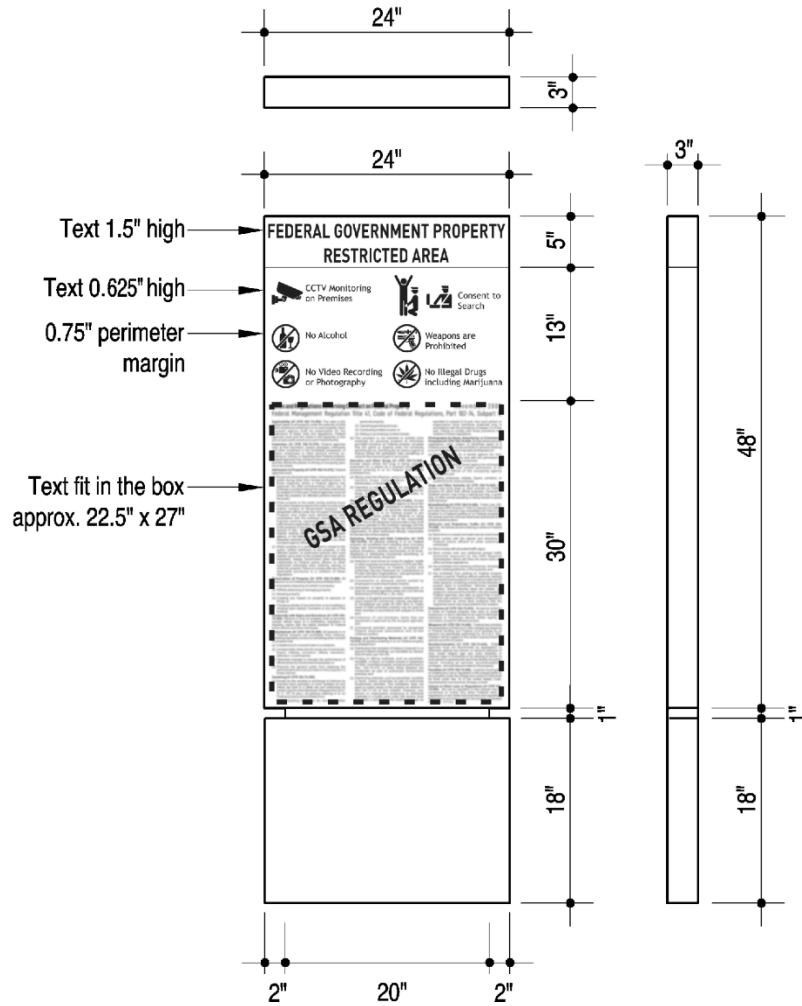

Pedestrian Directional and Regulatory Sign

4-panel pylon with LED lighting between cap and top of pylon.

Messages

Directional panels: 2-4 destinations, depending on number of arrows necessary. Distance to destination optional.

Regulatory panels: An adapted version of the GSA Regulatory Sign.

Typefaces

DIN Black and DIN Medium.

Arrows, walking figure and regulatory icons from provided artwork.

Lighting

LED lighting to be powered by solar panel, manufacturer to determine size and placement.

The directional message in the image at the right and the drawings following is a representation only. Actual content will be noted on a Pedestrian Signage Message Schedule, provided separately.



Pedestrian Directional and Regulatory Sign Dimensions

Dimensions

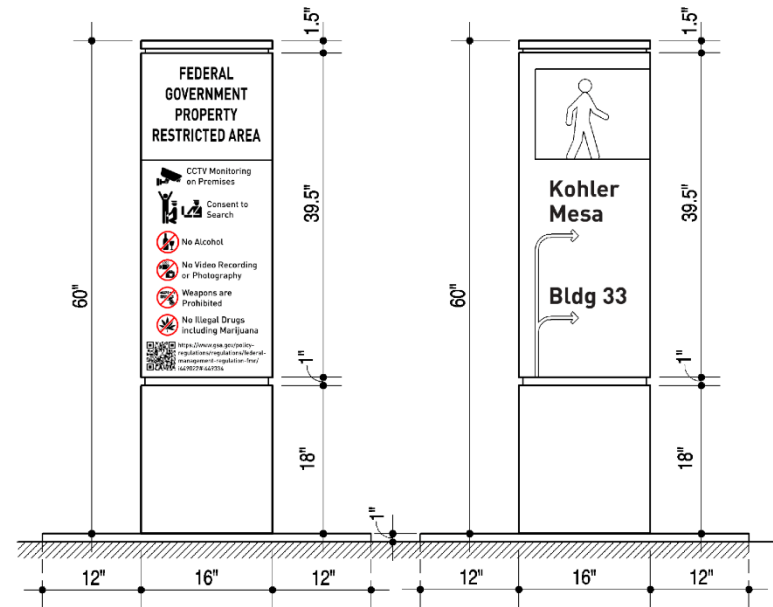
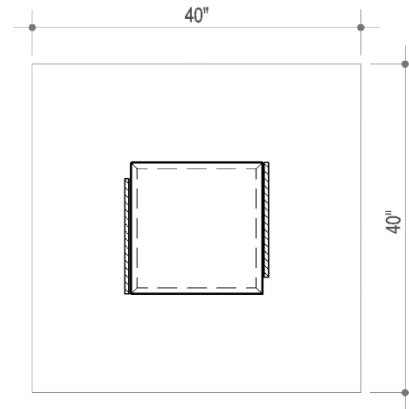
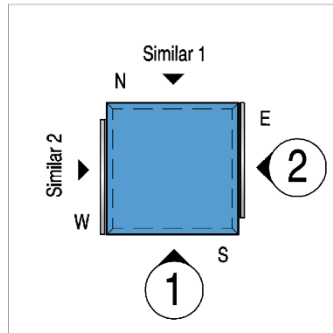

Four perpendicular panels mounted on an 18" high concrete base (see structural notes on page 45) with a 1" fabricated aluminum reinforced pan reveal. A 1" high mowing strip extends 12" on all sides.

Signs are installed where trails enter the campus and at major decision points.

Directional Panels - 2

16" x 39.5" x 1/8" to 1/4" flat aluminum panel, NIST Blue front, back, and all returns.

14"x11"x 1/8" to 1/4" flat anodized aluminum panel with water jet cut walking icon may be fastened to blue panel with 1/8" spacers as required.

Regulatory Panels - 2

16" x 39.5" x 1/8" to 1/4" flat aluminum panel, top 13" painted NIST Blue front, back, and all returns.

Cap and Lighting

16"x16"x1" tall NIST Blue aluminum cap, 1/2" gap beneath for solar-powered LED lighting.

Messages

Directional Panels - Letters and artwork are etched and infill-painted in white.

Regulatory Panel - Lettering in blue area is etched and infill-painted in white. Lettering on anodized panel is direct digital print in black and red.

Pedestrian Directional and Regulatory Sign

Dimensions, continued

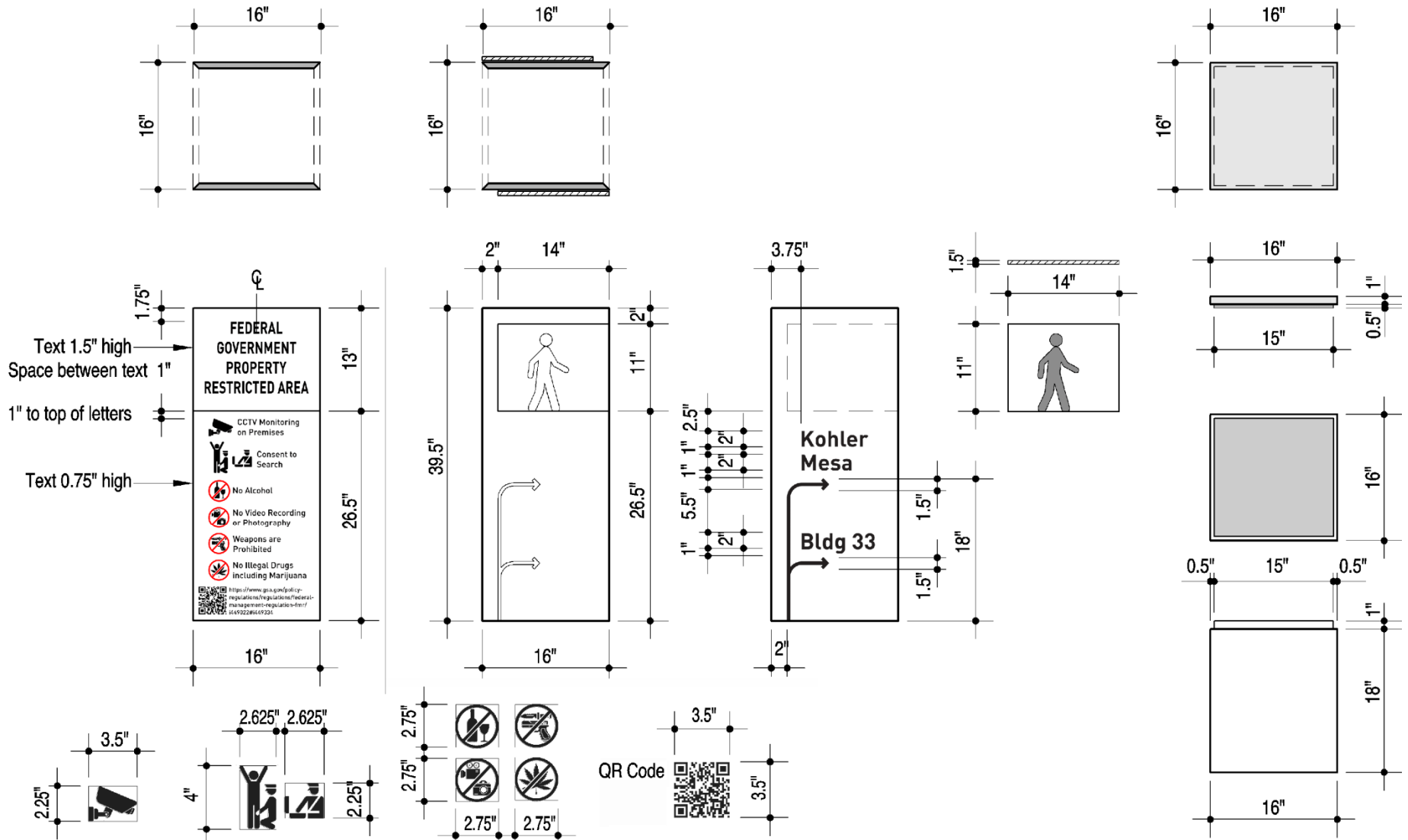

Security Center Sign Locations



- 1** 2-sided signs:
 Face 1: Do Not Enter
 Face 2: Yield
 Refer to Colorado Department of Transportation Signage Standards:
<https://codot.gov/content/library/traffic/shs/SHS.html>

- 2** Security Center sign, directing vehicles to turn in.
3 Full-sized GSA Regulatory sign.
4 Wall or pole-mounted GSA Regulatory Flag Attachment.

The Security Center will also have a Building Identification Sign, location tbd.

Security Center Directional Sign

Panels

Two-sided.

Messages

Back panel: arrow and "Security Center"
Front panel: "All Visitors" and "All Deliveries"; one more line of text if necessary.

Typefaces

"Security Center": DIN Medium Bold.
"All Visitors" and "All Deliveries":
DIN Medium.
Arrow from provided art.



Security Center Directional Sign

Dimensions

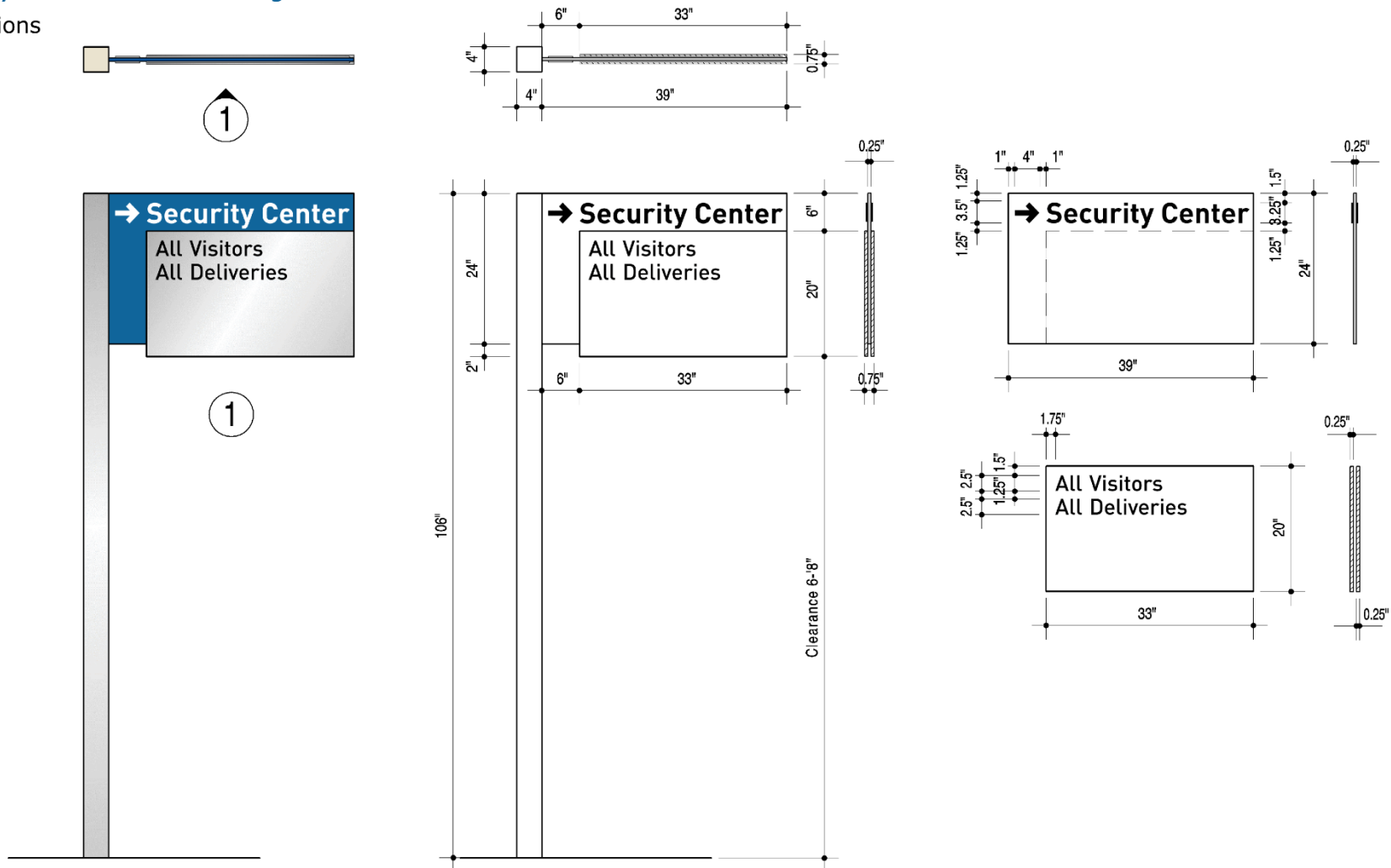

Sign is composed of one back panel and two message panels mechanically fastened to a 106" tall, 4" square metal post set into concrete footer (see structural notes on page 45), fastening mechanism determined by fabricator.

Installed perpendicular to street at drive entrance to the Security Center. Text aligns left.

Back Panel

1/4" fabricated aluminum, NIST blue on all visible sides, 24" high, 39" wide.

Arrows and letters are anodized aluminum. 3.25" cap height letters. Arrows on both sides are 4" wide (measured with arrow point left or right) and 3.5" high.

Message Panels

Two 20" high, 33" wide, 1/4" thick fabricated anodized aluminum panels.

2.5" cap height letters etched into panels and paint-infilled black.

Mechanically fastened flush to back panel.

Post

One 106"x4"x4" square metal post set into concrete footer, depth below grade to be determined.

Mechanism of attaching sign to post to be determined by fabricator.

Design Standards for Interior Signs

Overhead Signage Directional



Identification



Wall Signage Directional

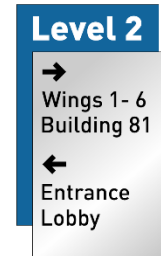

Room Identification



Other Identification



Emergency

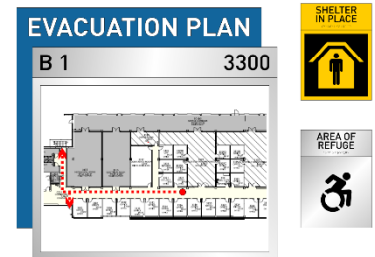

Overhead Directional Signage

Panels

Two-sided.

Messages

Destinations listed in number order. If multiple destinations in one direction, listed in order of encounter, with the exception of icons, which would always be shown last.

Maximum four lines of information per side (2 lines in 2 columns).

Typefaces

Text: DIN Medium.

Arrows and Icons

From provided art.

Headroom:

IBC 1003.3.1 Headroom

Protruding objects are permitted to extend below the minimum ceiling height required by code [Section 1003.2] where a minimum headroom of 80" is provided over any walking surface.

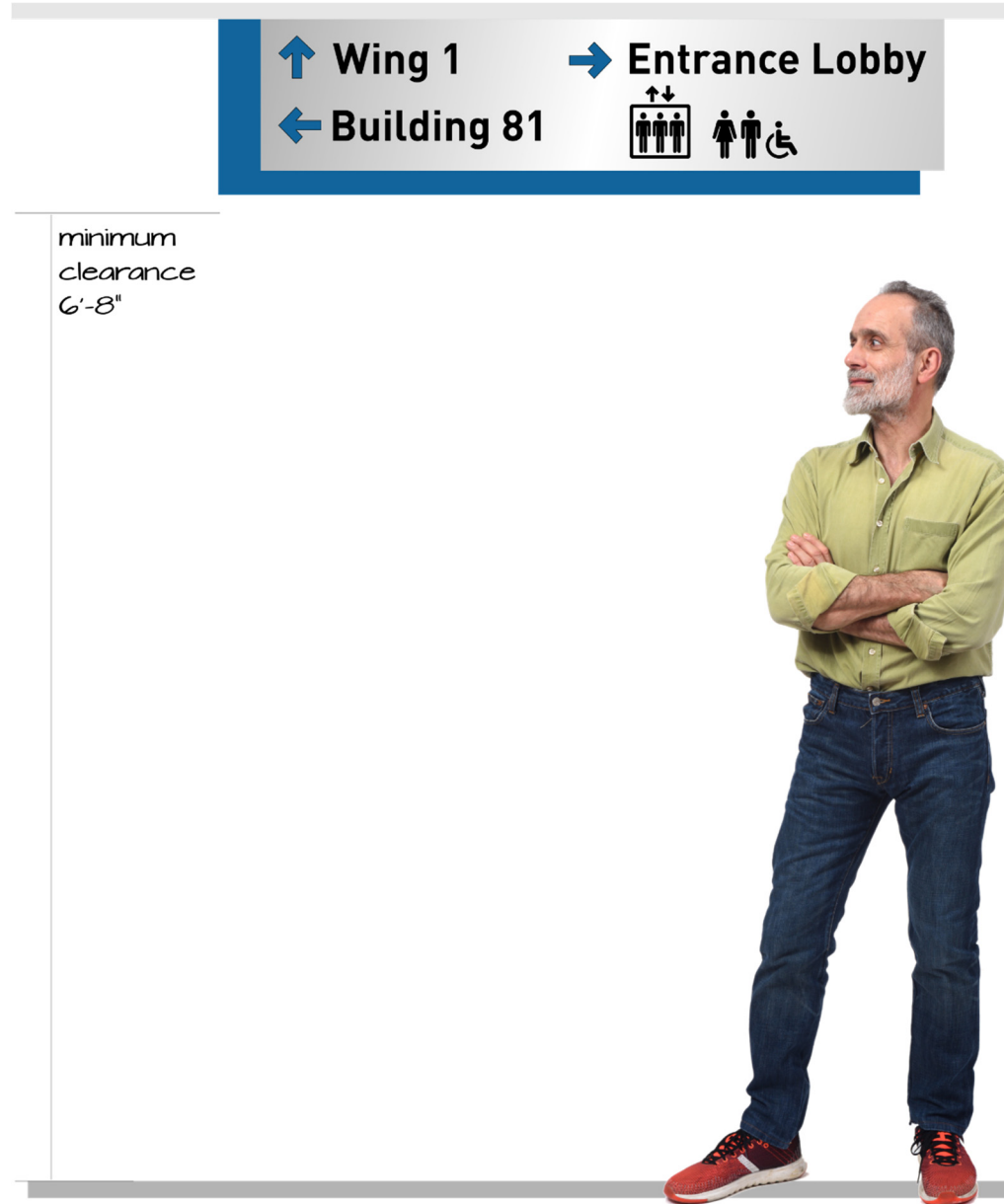

Overhead Directional Sign

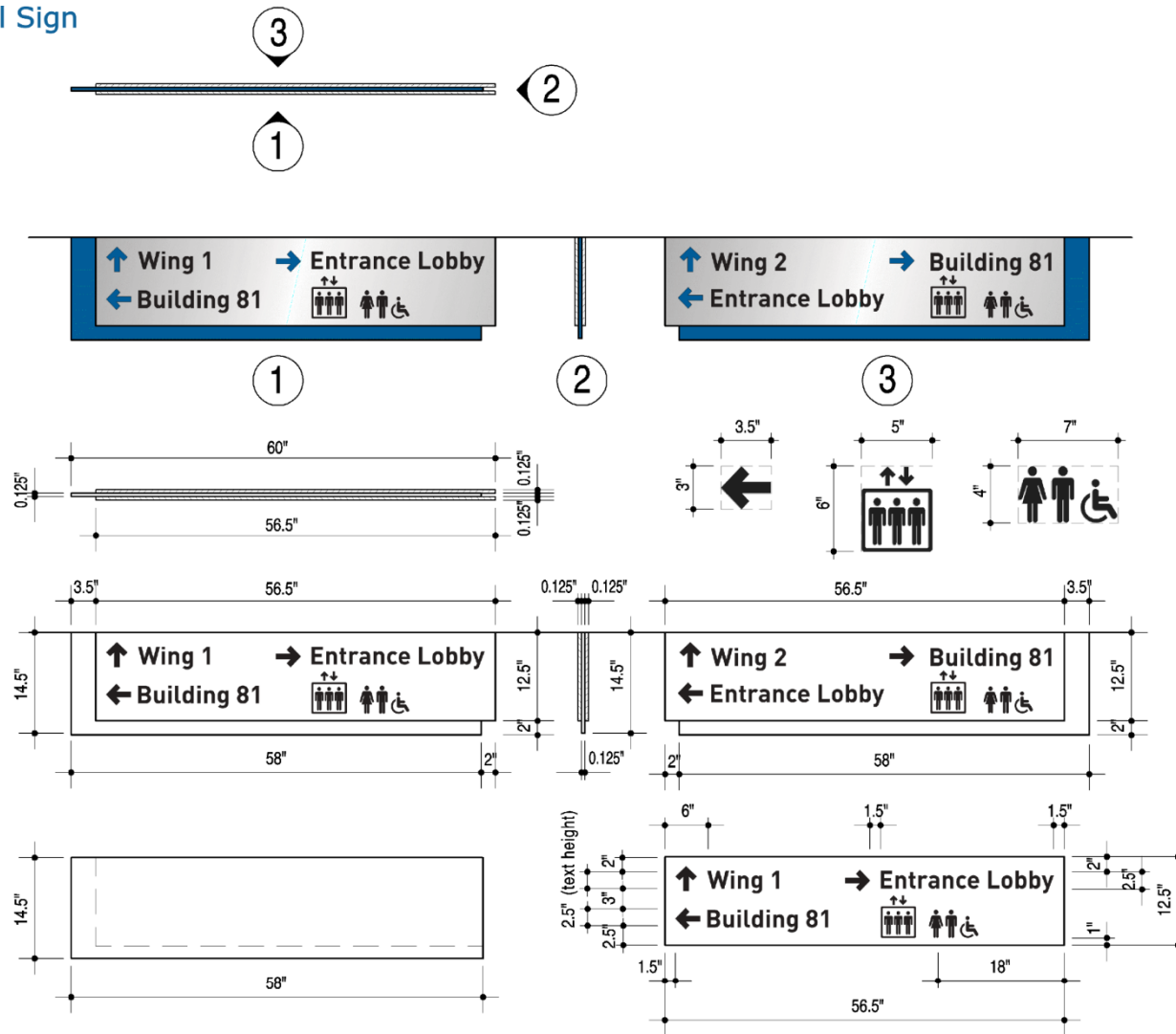

Signs are composed of one back panel and one or two directional panels mechanically fastened flush to ceiling. Bottom of sign to be not less than 80" AFF.

Back panel

One 58"x14-1/2"x1/8" flat anodized aluminum panel, NIST Blue front, back, and all returns.

Directional panels

One or two 56-1/2"x12-1/2"x1/8" flat anodized aluminum panels with 2.5" high letters and numbers etched and paint-infilled black. Arrows etched, infill painted blue.

Message panels adhere flush to back panel.

Installation

Sign mounts flush to ceiling with bottom of sign not less than 80" AFF.

Overhead Identification Signage

Panels

Two-sided.

Typeface

Messages: DIN Bold.

Arrows

From provided art.

Headroom:

IBC 1003.3.1 Headroom

Protruding objects are permitted to extend below the minimum ceiling height required by code [Section 1003.2] where a minimum headroom of 80" is provided over any walking surface.

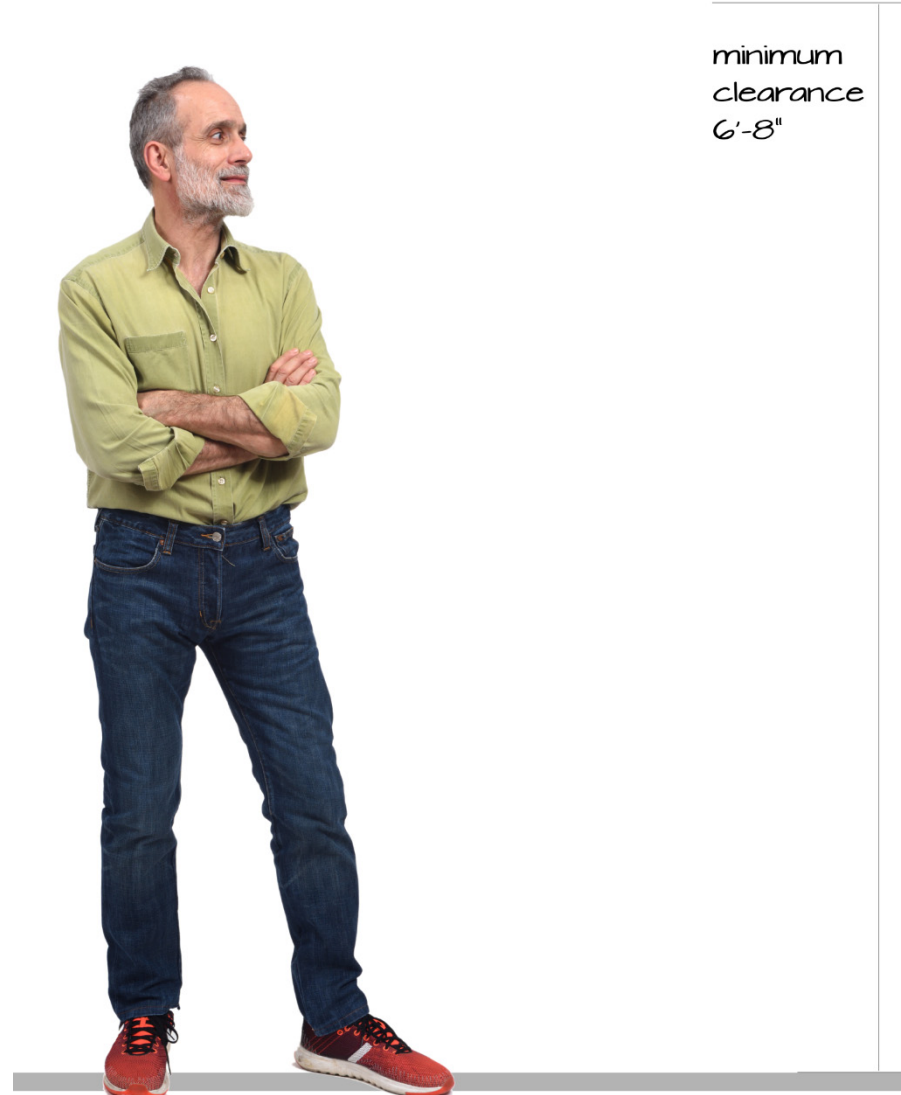

Overhead Identification Signage

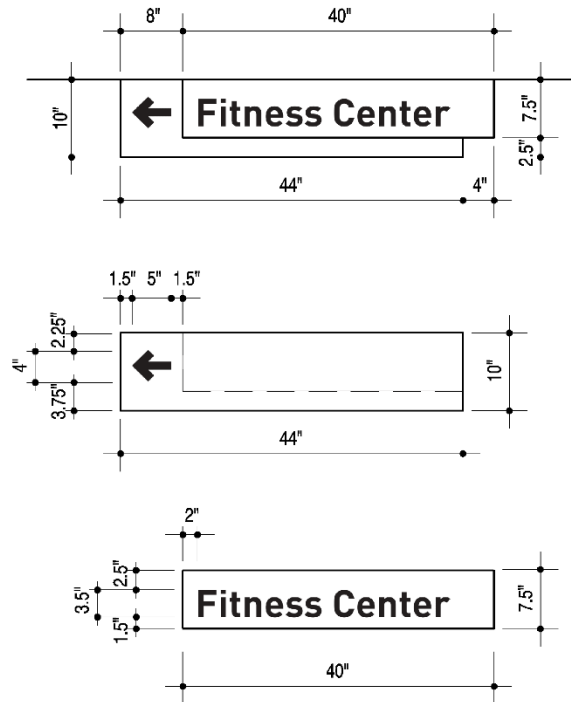
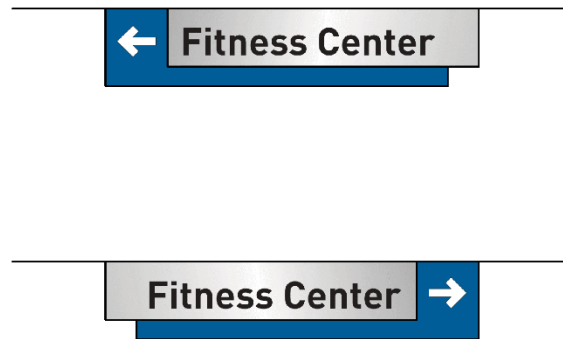

Signs are composed of one back panel and one or two directional panels mechanically fastened flush to ceiling. Bottom of sign to be not less than 80" AFF.

Back panel

One 44" x 10", 1/8" to 1/4" thick flat aluminum panel, NIST Blue front, back, and all returns.
4" high x 5" wide, 1/2" thick, cut white acrylic arrow adhered flush to back panel.

Message panels

One or two 40" x 7-1/2", 1/8" to 1/4" thick flat anodized aluminum panels with 3-1/2" letters etched and paint-infilled black.
Message panels adhere flush to back panel.

Installation

Sign mounts flush to ceiling with bottom of sign not less than 80" AFF.

Wall-Mounted Directional Signage

Messages

Destinations listed based on order of approach.

Maximum five destinations per panel.

Typefaces

Floor or Stair Name: DIN Black.

Building names: DIN Medium.

Arrows

From provided art.

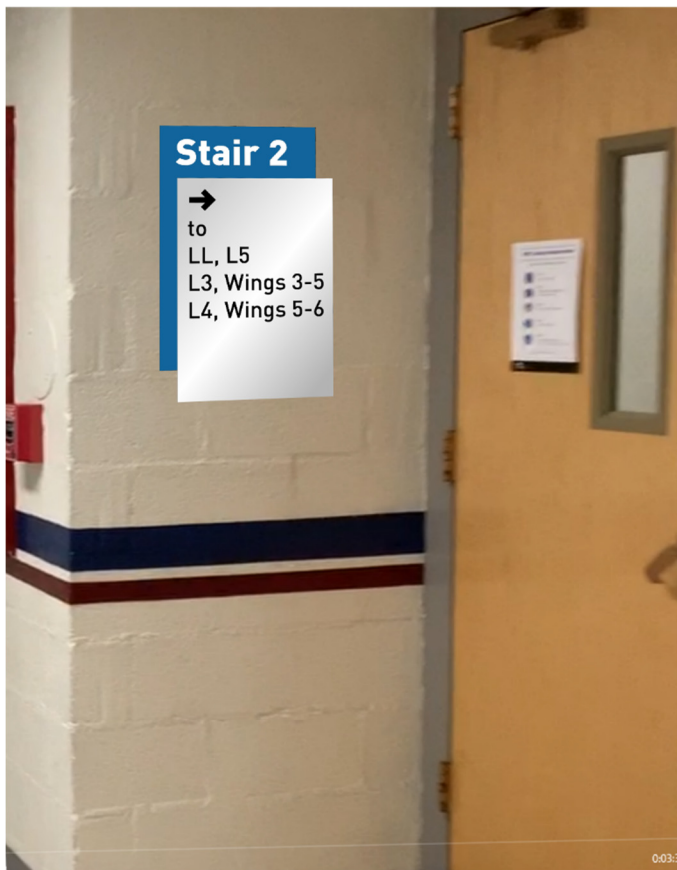

Wall-Mounted Directional Signage



Signs are composed of one back panel and one directional panel mechanically fastened flush to wall.

Back panel

One 18" wide, 28" tall, 1/8" thick flat aluminum panel, NIST Blue front, back, and all returns.

3" high letters/numerals etched and paint-infilled white.

Directional panel

One 26" high, 18" wide, 1/8" thick flat anodized aluminum panel with 2" high letters/numerals and 2-1/2" tall arrow etched and paint-infilled black.

Message panel adhered to back panel.

Installation

Sign mounts flush to wall.

Sign shall not be placed less than 6" away from any door jamb or structural/architectural feature, such as a corner or protruding column.

Bottom of sign to be 52" above finished floor.

Wall-Mounted Directional Signage

Dimensions

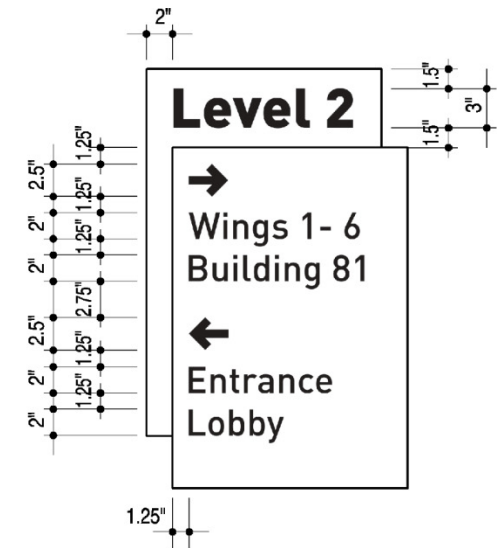
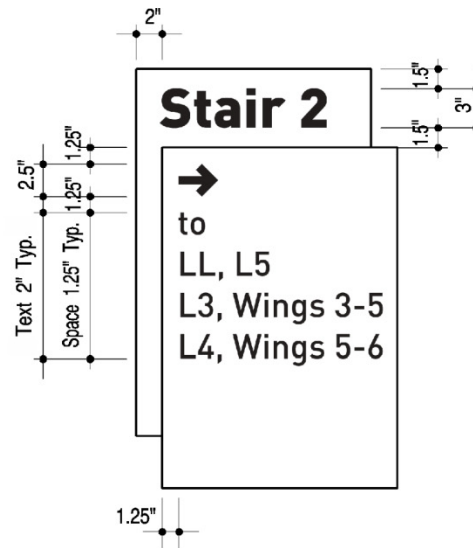
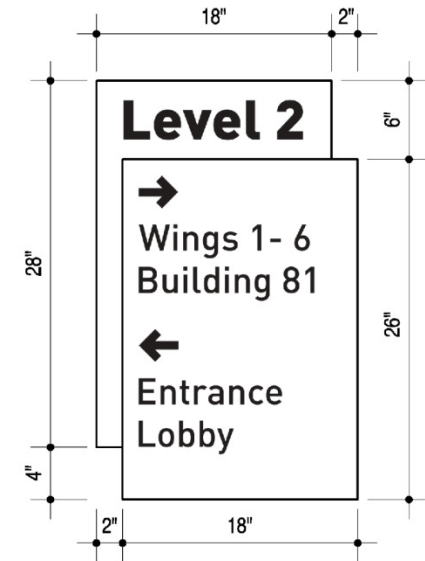
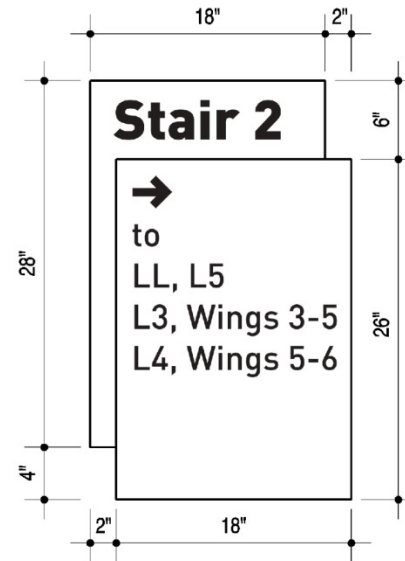
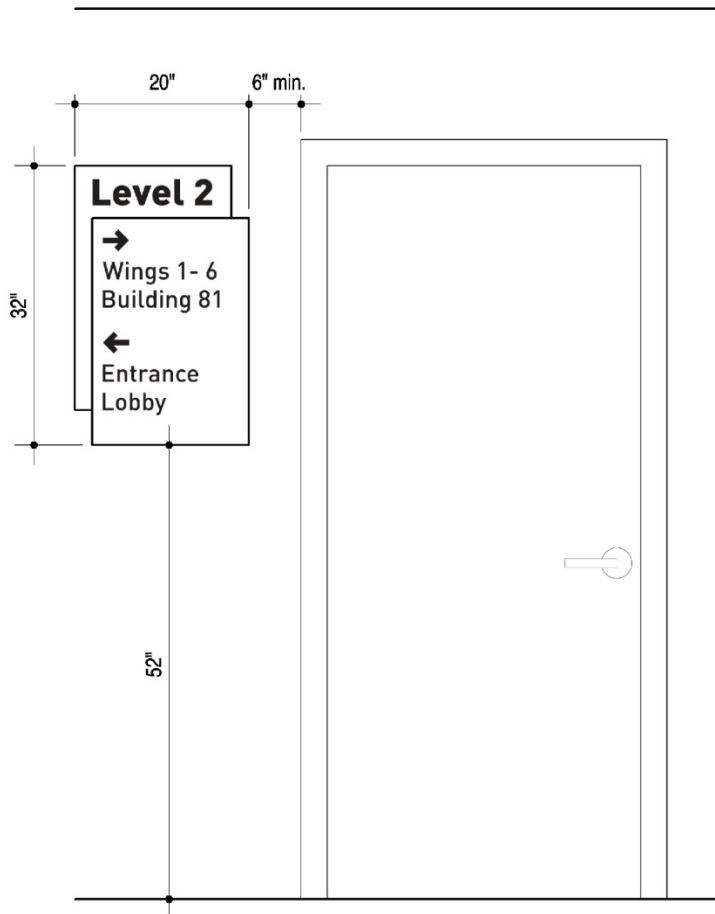

Wall-Mounted Room and Door Identification Signage

Panels

Flat, anodized aluminum.

Messages

U.S. Federal conforming raised characters and Grade 2 Braille
 Building number, room number, messages, icons.

Typefaces

Building and room letters/
 numbers: DIN Medium.

Room names: DIN
 Medium, all caps.

Employee names,
 titles: DIN Regular.

Grade 2 Braille.

Signs mount flush to
 wall at latch side of
 door, vertical center
 of sign is 5'-0" above
 finished floor (AFF).

Icons

From provided
 artwork.

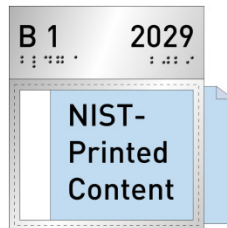

Wall-Mounted Room and Door Identification Signage

Building Name and Number only,
and with Changeable Insert
Dimensions

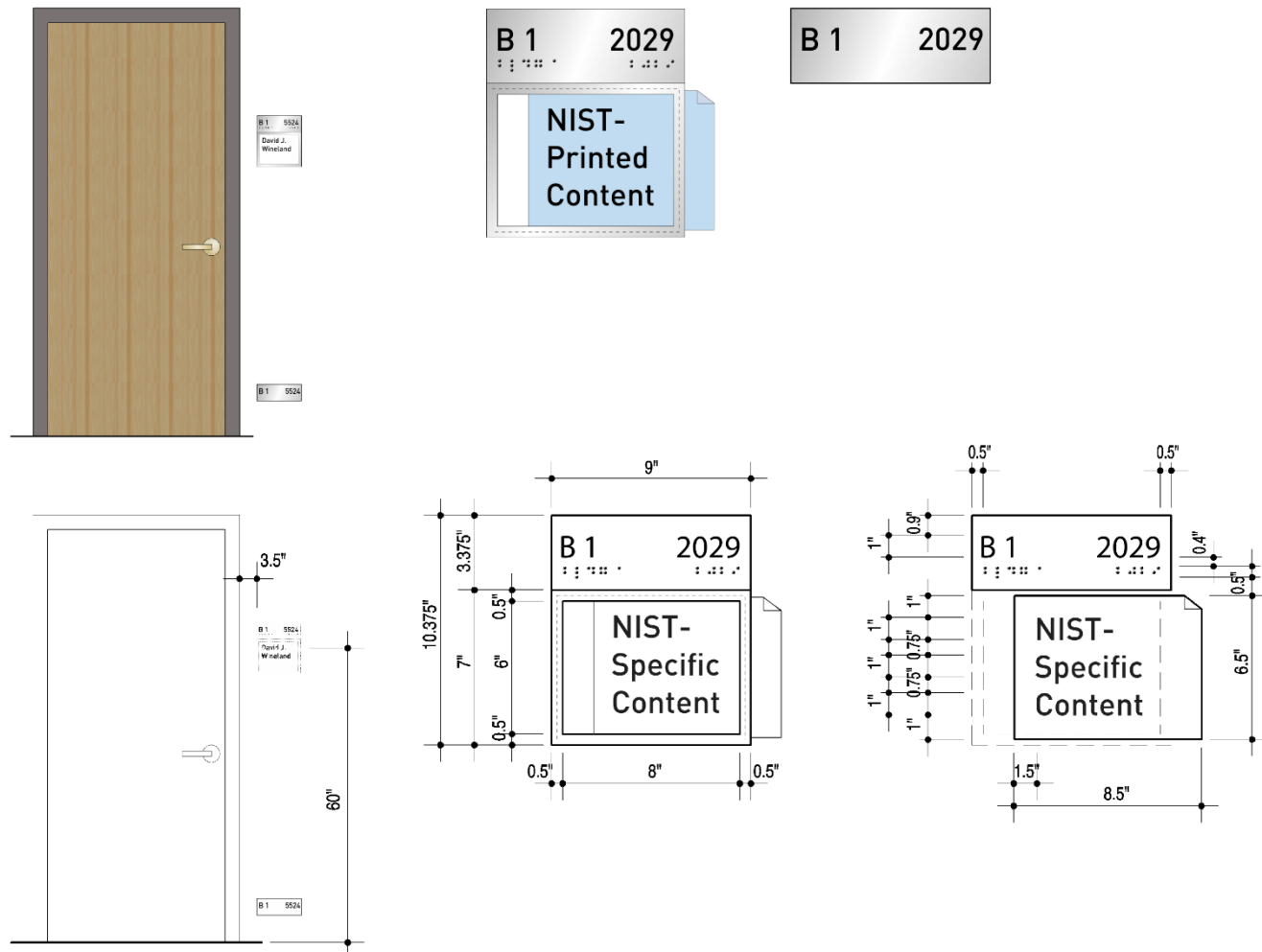

Application

Signs for rooms whose occupants and/or purpose changes frequently.

Fire Fighter Room Identification Sign composed of same top panel as Room ID sign, with U.S. Federal conforming raised numbers/letters, at least 1/32" above background, mounted near floor directly under Room ID sign.

Top panel - Both signs

As a stand alone, and as part of the larger sign.

One 9" wide, 3-3/8" high, 1/8" thick flat anodized aluminum plaque with 1" tall tactile characters raised 1/32" minimum above their background, painted black. Accompanying Grade 2 Braille on room ID only.

Changeable insert frame - Room ID

One 9" wide, 7" tall, 1/8" thick anodized aluminum frame with window for changeable paper insert.

Insert - Room ID

8-1/2" x 6.5" durable paper that can be laser or ink-jet printed by NIST on-site.

Assembly - Room ID

Top panel and changeable insert frame permanently adhere to 9" wide, 10-3/8" tall, 1/8" thick anodized aluminum back panel.

Installation - Room ID

Mount vertically centered at 60" AFF, 3.5" from jamb, latch side of door.

Wall-Mounted Room and Door Identification Signage

Permanently Assigned Rooms
Flexible Use Rooms
Dimensions

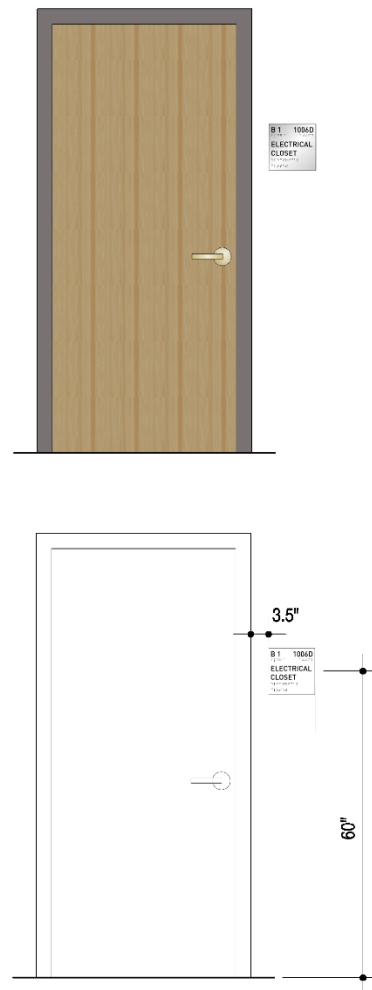

Permanent Sign

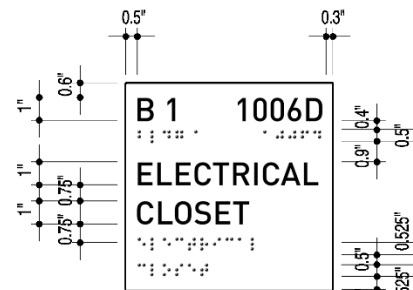
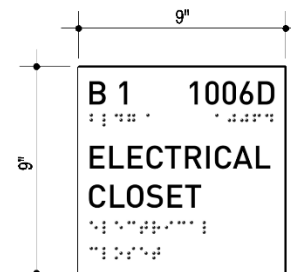
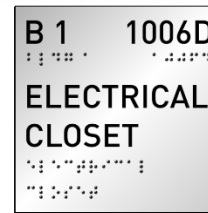

Flexible Sign

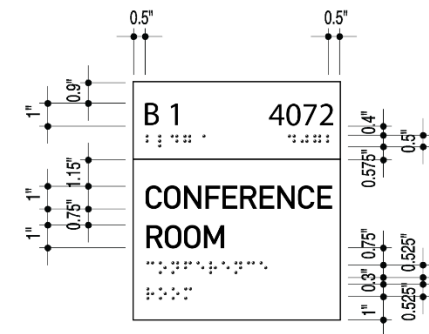
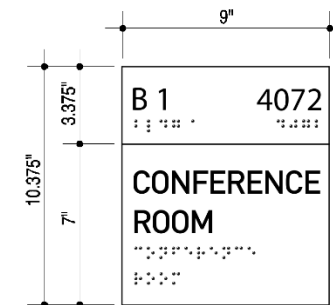

Installation

Signs vertically centered at 60" AFF on wall, 3.5" from jamb, latch side of door.

Permanent Sign

For rooms whose use would not typically change.

Flexible-Use Sign

For rooms whose use may change, but not frequently.

Permanent Sign - Plaque

9" x 9" x 1/8" flat anodized aluminum.

Permanent Sign - Message

1" tall tactile characters raised 1/32" minimum above their background, painted black and accompanying Grade 2 Braille.

Flexible Sign - Top panel

One 9"x3-3/8"x1/8" flat anodized aluminum plaque with 1" tall tactile characters raised 1/32" minimum above their background, painted black and accompanying Grade 2 Braille.

Flexible Sign - Message panel

9"x7"x1/8" anodized aluminum plaque. 1" tall tactile characters raised 1/32"

minimum above background, painted black and accompanying Grade 2 Braille.

Flexible Sign Assembly

Top panel permanently adheres to 9"x10-3/8"x1/8" anodized aluminum back panel. Message panel magnetically fastens to back panel.

Wall-Mounted Room and Door Identification Signage

Restrooms and New Mother's Room
Dimensions

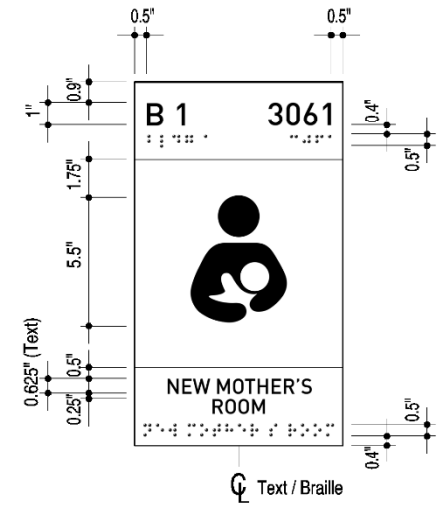
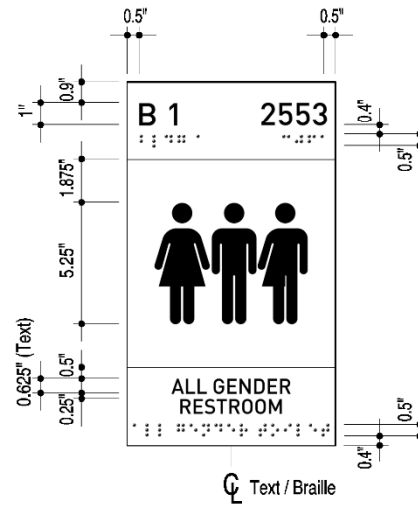
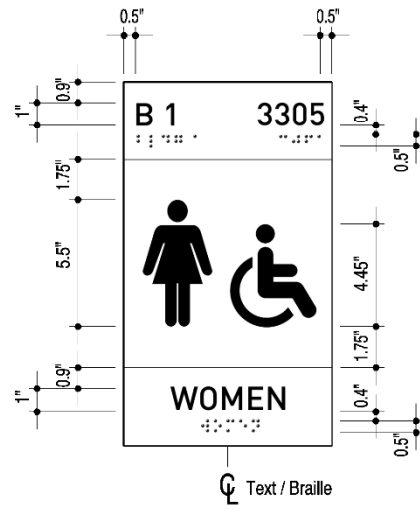
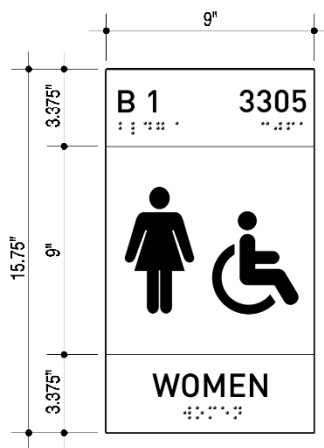
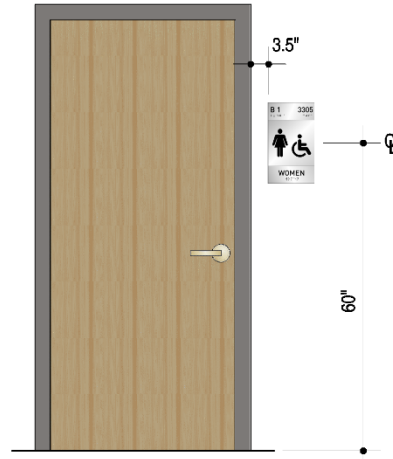

Signs have one panel, 9" wide, 15-3/4" tall, and 1/8" thick of flat anodized aluminum plaque with Grade 2 Braille and U.S. Federal conforming raised messages and gender icons.

Installation

Sign mounts centered at 60" AFF on wall, 3.5" from jamb, latch side of door.

Top segment

3-3/8" tall. 1" tall tactile characters raised 1/32" minimum above their background, painted black and accompanying Grade 2 Braille.

An etched and paint-infilled black horizontal line separates this segment from the one below.

Icon segment

9" tall segment. Icons are raised (minimum of 1/32" high) and painted black. See above drawings for icon dimensions.

An etched and paint-infilled black horizontal line separates this segment from the one below.

Message segment

3-3/8" tall. Tactile characters raised 1/32" minimum above their background, painted black and accompanying Grade 2 Braille. See above drawings for letter dimensions.

Wall-Mounted Room and Door Identification Signage

Elevators and Stairs

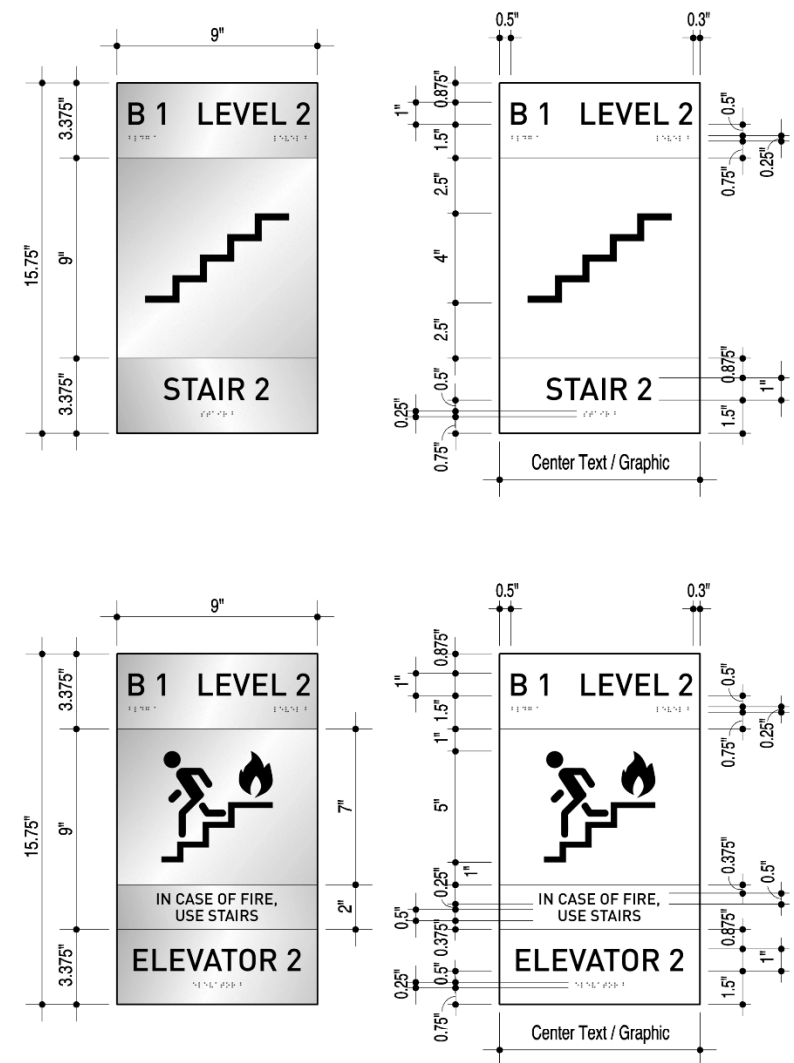

Permanent Sign

9" wide by 15.75" tall by 1/8" thick anodized aluminum sign identifying stairways and elevators.

Installation

Both signs mount centered at 60" AFF on wall, 3.5" from door frame, latch side of door (for stairs).

Top and Bottom segments

3-3/8" tall. Letters and numerals: 1" tall tactile characters raised 1/32" minimum above background, painted black and accompanying Grade 2 Braille.

An etched horizontal line, infill painted black separates the segments.

Icon segment

9" x 9" segment (stairs) and 9" x 7" segment (elevator). Pictograms/icons are centered in segment, raised at least 1/32" above background and painted black. See above drawings for icon dimensions.

Elevator sign additional segment

9" x 2" segment between icon segment and bottom segment. 1/2" tall tactile characters raised 1/32" minimum above their background, painted black and accompanying Grade 2 Braille.

Wall-Mounted Emergency Signage

Panels

Flat, anodized aluminum.

Typefaces

Building and room letters and numbers: DIN Medium.

Signs mount flush to wall, vertical center of sign is 5'-0" above finished floor (AFF).

Icons

From provided artwork.

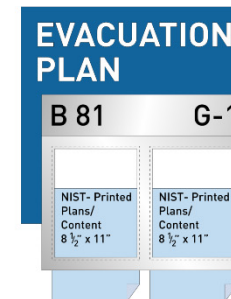
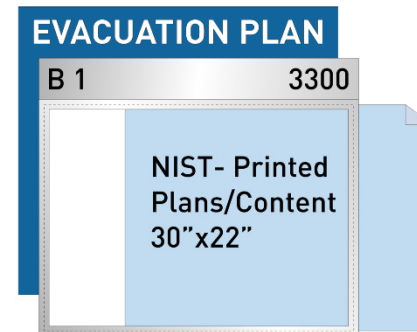
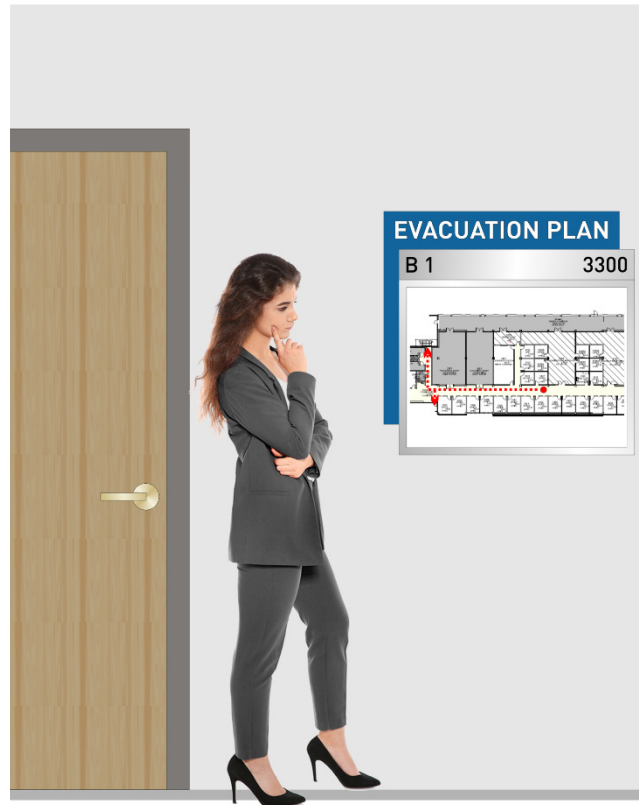

Wall-Mounted Emergency Signage

Dimensions for Evacuation Signs

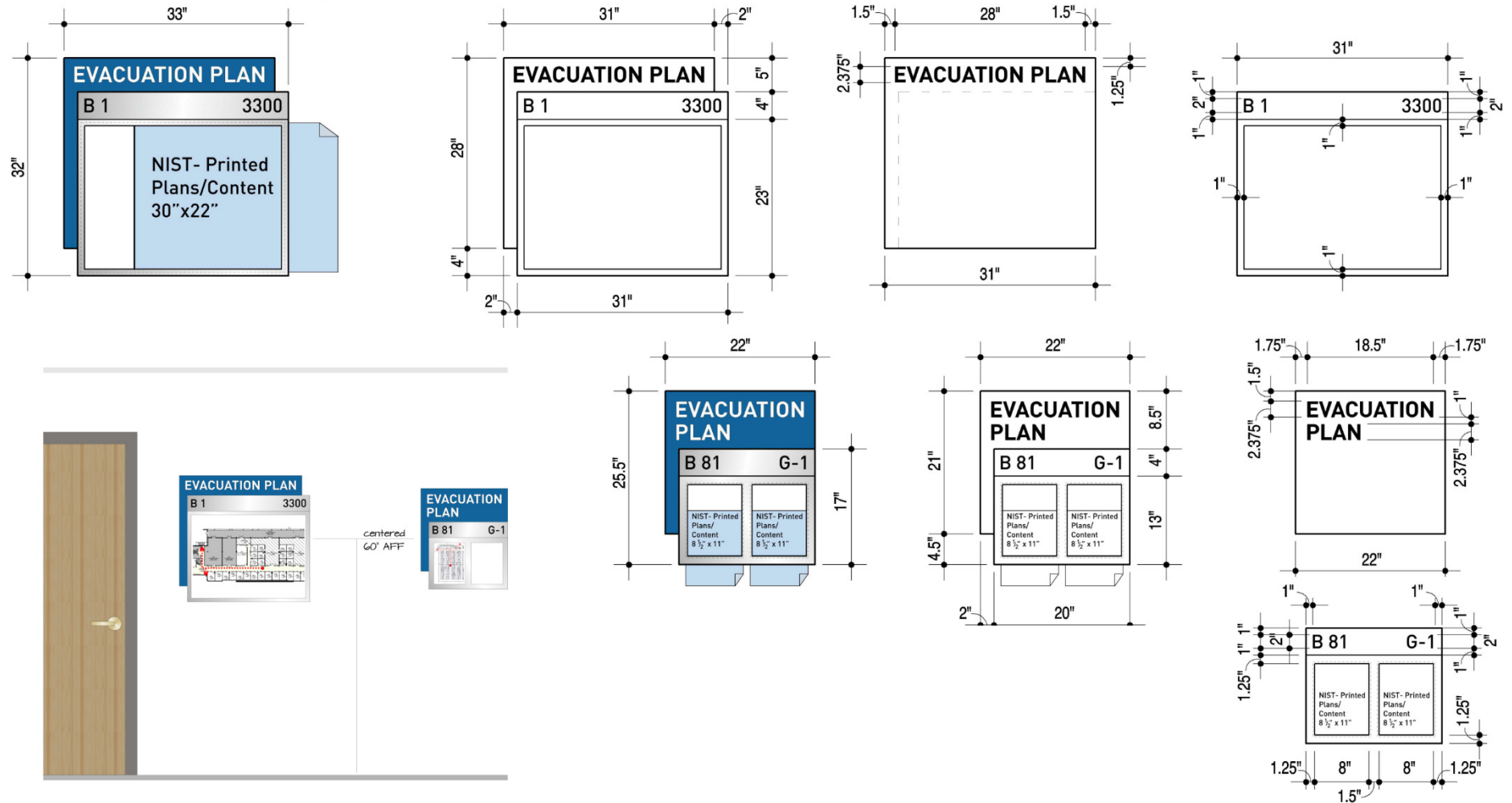

Signs are composed of one back panel and one directional panel mechanically fastened flush to wall.

Back panel

1/8" thick flat aluminum panel, NIST Blue front, back, and all returns. 2.375" high letters etched and paint-infilled white.

Back panel - Large sign: 31" w x 28" h

Back panel - Small sign: 22" w x 21" h

Directional panel - Top segment

1/8" thick flat anodized aluminum panel with 2" high letters/numerals etched and paint-infilled black. Both signs: 4" high, **large** is 31" w, **small** is 20" w. Message panel adhered flush to back panel.

Changeable insert frame - Large

One 31" wide, 23" tall, 1/8" thick anodized aluminum frame with 1" bordered window for changeable insert.

Changeable insert frame - Small

One 20" wide, 13" tall, 1/8" thick anodized aluminum frame with (2) 1.25" bordered windows for changeable insert.

Installation

Sign mounts flush to wall.

Sign shall not be placed less than 6" away from any door jamb or structural/architectural feature, such as a corner or protruding column.

Vertically centered 60" AFF.

Wall-Mounted Emergency Signage

Dimensions for Area of Refuge and Shelter in Place Signs

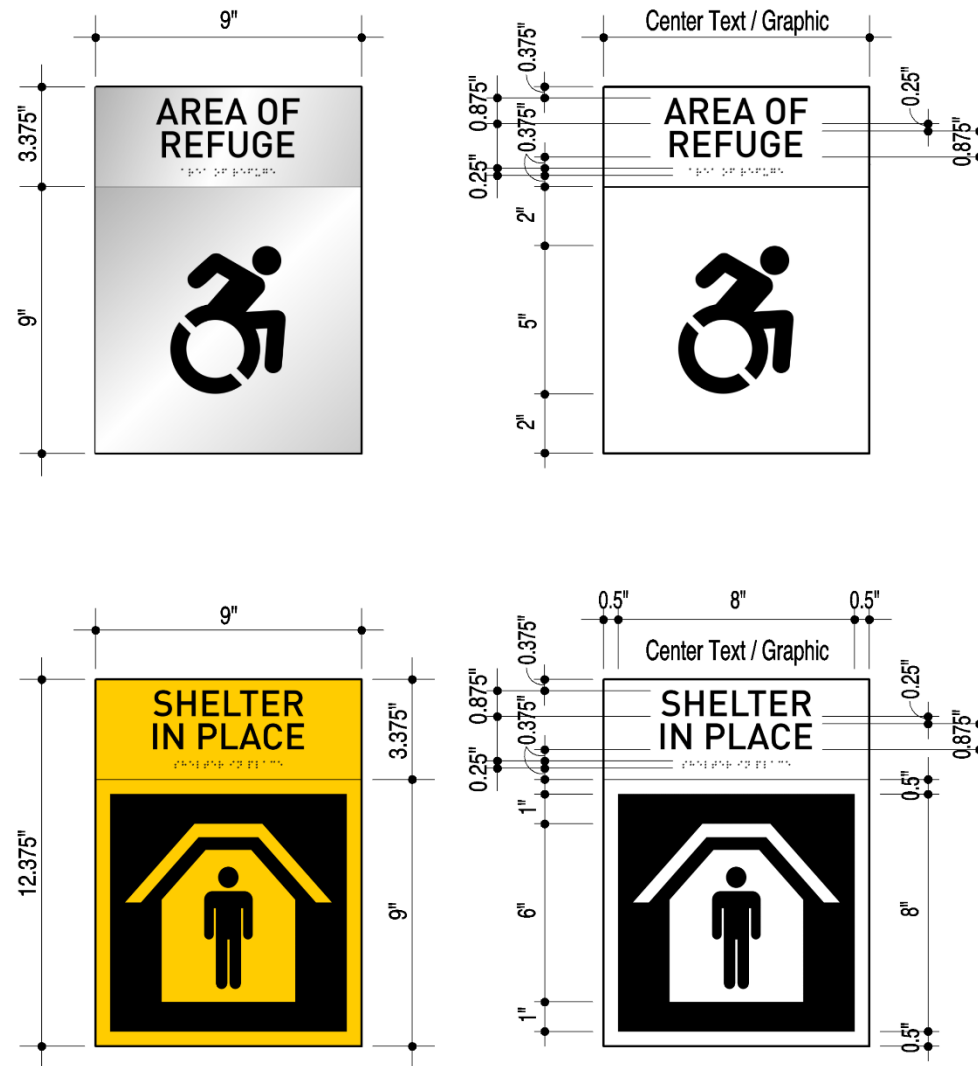

Installation

For rooms designated for use in emergency situations.

Signs are composed of a single plaque, 9" wide, 12 3/8" tall, 1/8" thick anodize aluminum. The Shelter in Place sign is painted yellow/gold, front, back and all returns.

Top Segment

9" wide by 3 3/8" high. Capital letters, 7/8" tall tactile characters raised 1/32" minimum above their background, painted black and accompanying Grade 2 Braille.

Icon/Pictogram Segment

9" x 9" with black tactile pictograms/icons, centered in field, raised a minimum of 1/32" above background. Dimensions for each shown in above drawings.

Installation

Attach flush to wall, vertically centered at 60" AFF, in proximity to room identification sign.

Fabrication and Installation Guidelines

1. General Standards/requirements for providers: Applicable to all signs - exterior, interior and specialty.
 - a. Quality. The materials, products, workmanship and installation must be of superior quality and conform to industry best practices.
 - b. Field evaluation. The provider must evaluate existing conditions and validate feasibility of installation of the sign/s being procured by NIST. Evaluation must consider structure, electrical infrastructure, data/communication distribution networks, potential encumbrances on security infrastructure (e.g. blocking security cameras), and general locational and placement attributes. The base height for ground mounted signs shall be evaluated based on the immediate surroundings. The base shall not be less than 12 inches and not more than 18 inches.
 - c. Permitting. NIST adheres to a 'good neighbor policy' and to the extent possible, follows the applicable local regulatory requirements. The provider must review compliance with all applicable regulatory requirements and notify NIST if any aspect of the sign/s in question are not in conformance. The provider shall be responsible for procuring required permits and obtaining variances (where needed).
 - d. Shop drawings: The design standards and specifications noted in this document are indicative of design intent. The provider shall prepare and submit shop drawings to NIST ahead of installation. The shop drawings must address conditions assessed as part of the field evaluation but follow the design intent to the maximum intent feasible. Cost, durability, ease of maintenance and performance over time must be considered along with original design intent. Any deviations to the original design intent must be called out and will require explicit approval of the NIST contracting officer's technical representative. A licensed structural engineer must sign and seal shop drawings attesting to the structural integrity of the signs and their ability to withstand winds up to 100 miles per hour, applicable snow loads, seismic loads, and other appropriate ambient conditions. Foundation/footing drawings must also be signed and sealed by a licensed structural engineer.
 - e. Mockups: If desired by NIST, the provider must arrange on-site mockups to ensure visibility under different conditions. If necessary, NIST may require changes to the materials, finishes and colors based on field assessments of the mockups.
 - f. Structural: The provider must assess structural requirements for the signs as part of the field evaluation. For exterior signs, wind loads (at least 100 miles per hour), snow loads, soil conditions, etc. must be taken into consideration. For interior signs, wall types, blocking requirements, power and data provisions will need to be assessed. Both exterior and interior sign installations must consider potential structural impact on historic resources. The structural integrity of all signage, support systems and foundations/footings are the responsibility of the sign provider.
 - g. Finish. Joints between various portions of signs that are not welded nor sealed, must have a tight, hairline-type appearance, without gaps. Exposed welded joints must be filled and ground smooth so that there is no seam visible. All pieces must be fastened and fabricated such that there is no looseness, racking, or movement. All fasteners shall be concealed unless otherwise specified.

2. Exterior Signage

a. Location and Placement.

- 1) General. The location and placement of exterior signs proximate to vehicular roads must ensure that visibility of motorists or other users are not impacted. In particular, the recommendations on site triangles noted in the latest version of "A Policy on Geometric Design of Highways and Streets" published by the American Association of State Highway and Transportation Officials (AASHTO) shall be followed. Signs shall not be placed within the public rights of way and preferably not within required setback distances. The signs shall also be compliant with the City of Boulder Municipal Code, particularly but not limited to Section 9-9-21 Signs. The visibility of all of these signs shall also be considered in conjunction of vegetation that may encumber the visibility of the signs and/or sight triangles.
 - 2) Campus Identification Sign and Regulatory Sign at King Avenue: The Campus Identification Sign and Regulatory Sign to be located at the King Avenue entrance shall be oriented to maximize visibility of incoming users – emergency responders, pedestrians, and bicyclists. The signs shall not encumber the sidewalk.
 - 3) Directional Signs. These signs are located at key intersections upon entering the campus. Generally, signs shall be located outside of vehicular sight triangles noted in Section 9.5.3 Intersection Control of the AASHTO Policy on Geometric Design of Highways and Streets.
 - 4) Parking Lot Identification and Directional Signs. These signs shall comply with the requirements/standards of the latest edition of the Manual on Uniform Traffic Control Devices. In general, no portion of the signs shall encumber within 2'-0" of the curb and shall have a minimum of 7'-0" clearance from the immediate grade.
 - 5) Free standing Building identification signs. The freestanding building signs shall be located near the primary campus road serving the respective building perpendicular to the road, at least two feet inside the sidewalk or 6 feet from the curb, whichever is greater. These signs shall be located proximate to the pedestrian walkway leading from the road to the primary entrance to the building.
 - 6) Pedestrian signs. Pedestrian signs shall be placed at intersections of sidewalks and trails that are not served by a primary or secondary directional sign. Pedestrian signs are also recommended for long stretches of trails (~300 feet) where directional signs are not visible.
- b. Vandalism. Campus identification and regulatory signs must be fabricated and installed in a fashion that can withstand severe abuse and resist vandalism.
 - c. Weatherproofing. Sign cabinet seams shall be sealed to ensure they are watertight. Finishes shall be free from fading, peeling or cracking. Inconspicuous drain holes shall be provided as needed to prevent water accumulation within signs. Drainage must not occur onto signs or other surfaces that can cause staining. Provide color-coordinated insect screening over drain holes.

3. Interior Signage

a. Location and Placement.

- 1) General. Directional signs shall preferably be located at all decision points within the spine. Directional signs are also needed near stairs and elevators. Overhead and protruding signs (such as flag signs) shall be compliant with the clearance requirements required by the latest edition of the International Building Code at the time of installation. While placing signs, relative location of all security devices (such as cameras) and life safety devices (such as alarms and exit signs) must be considered and any conflicts must be discussed with NIST Contracting Officer's Representative (COR) for a resolution prior to development of shop drawings.
- 2) Overhead Directional Signs. These are the preferred directional signs where adequate clearance is available and directional notification is needed on a continuing corridor. Placement shall maximize visibility and minimize confusion.
- 3) Wall mounted and flag mounted directional signs. These signs are to be installed where ceiling height limitations do not allow installation of overhead directional signs.

- b. Raised characters and Braille. Interior identification signs shall have raised characters and braille in accordance with sections 703.2, 703.3 and 703.4 of the Architectural Barriers Act (ABA) Standards. The NIST COR may require additional signs to have braille as deemed necessary.

- c. Illumination. To the extent possible, sign placement shall be such that ambient light (from natural and/or artificial light sources) is adequate for the sign to be legible for users. If other placement restrictions prevent legibility of sign using ambient lighting, the provider must incorporate external illumination options based on the field inspection for review and selection by NIST COR.