

NIST PMI Test Models - 2012

Test Model 2

NOTES (UNLESS OTHERWISE SPECIFIED):

1. OBTAIN DIMENSIONS FOR ALL UNDIMENSIONED FEATURES FROM THE MODEL. ALL DIMENSIONS OBTAINED FROM THE MODEL ARE BASIC UNLESS OTHERWISE SPECIFIED.
2. ASME Y14.41-2003 APPLIES TO DATASET.
3. ASME Y14.5M-1994 APPLIES TO DIMENSIONING AND TOLERANCING.

↑
These notes shall be placed on a static annotation plane (the plane does not rotate with the model).

The intent of ATC50 is to test systems' support for static annotation planes.

Including a feature control frame in a general note will be a test case in the next round of testing.

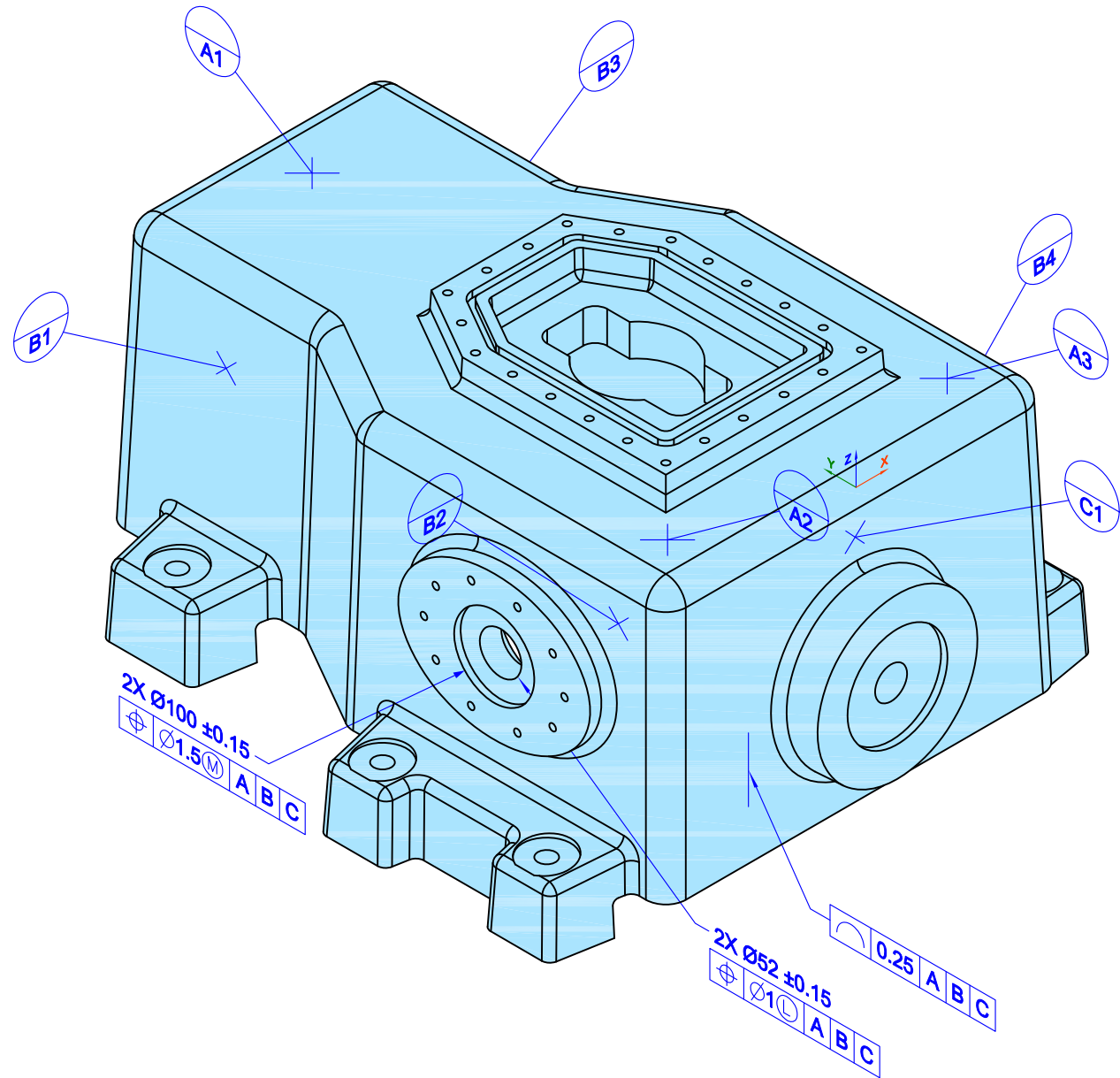

PMI Complex Test Case 2 - View 1 (of 3)
Includes Atomic Test Cases - 28, 29, 43, 47, 50

NIST PMI Test Models - 2012

Test Model 2

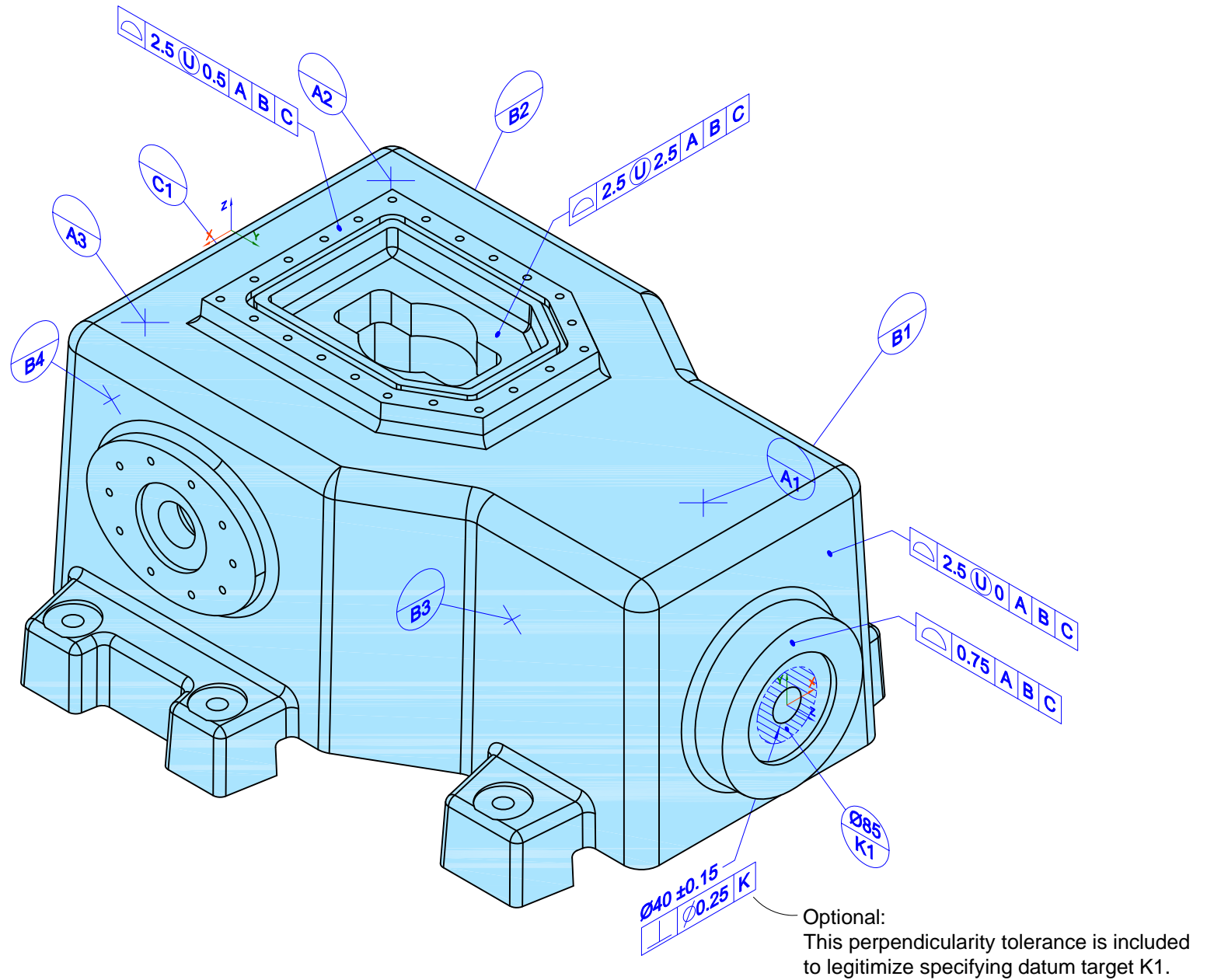

PMI Complex Test Case 2 - View 2 (of 3)
Includes Atomic Test Cases - 26, 31, 41

