

NIST PMI Test Models - 2014

NOTES (UNLESS OTHERWISE SPECIFIED):

- CAD MODEL _____ REV. __ IS REQUIRED TO COMPLETE PRODUCT DEFINITION.
- DIRECTLY-TOLERANCED DIMENSIONS AND BASIC DIMENSIONS DEFINED ON THE DRAWING TAKE PRECEDENCE OVER DIMENSIONAL DATA DEFINED BY THE MODEL. OBTAIN ALL OTHER DIMENSIONAL DATA FROM THE MODEL. THE MODEL REPRESENTS BASIC DIMENSIONAL DATA UNLESS OTHERWISE SPECIFIED.
- APPLICABLE STANDARDS:
ASME Y14.41-2003 APPLIES TO DATASET.
ASME Y14.5M-1994 APPLIES TO DIMENSIONING AND TOLERANCING.
-  .05 A B C APPLIES TO ALL UNTOLERANCED SURFACES.
- UNITS: INCHES

Feature and Specification Index
nist_ftc_06_asme1_rd_fsi.pdf

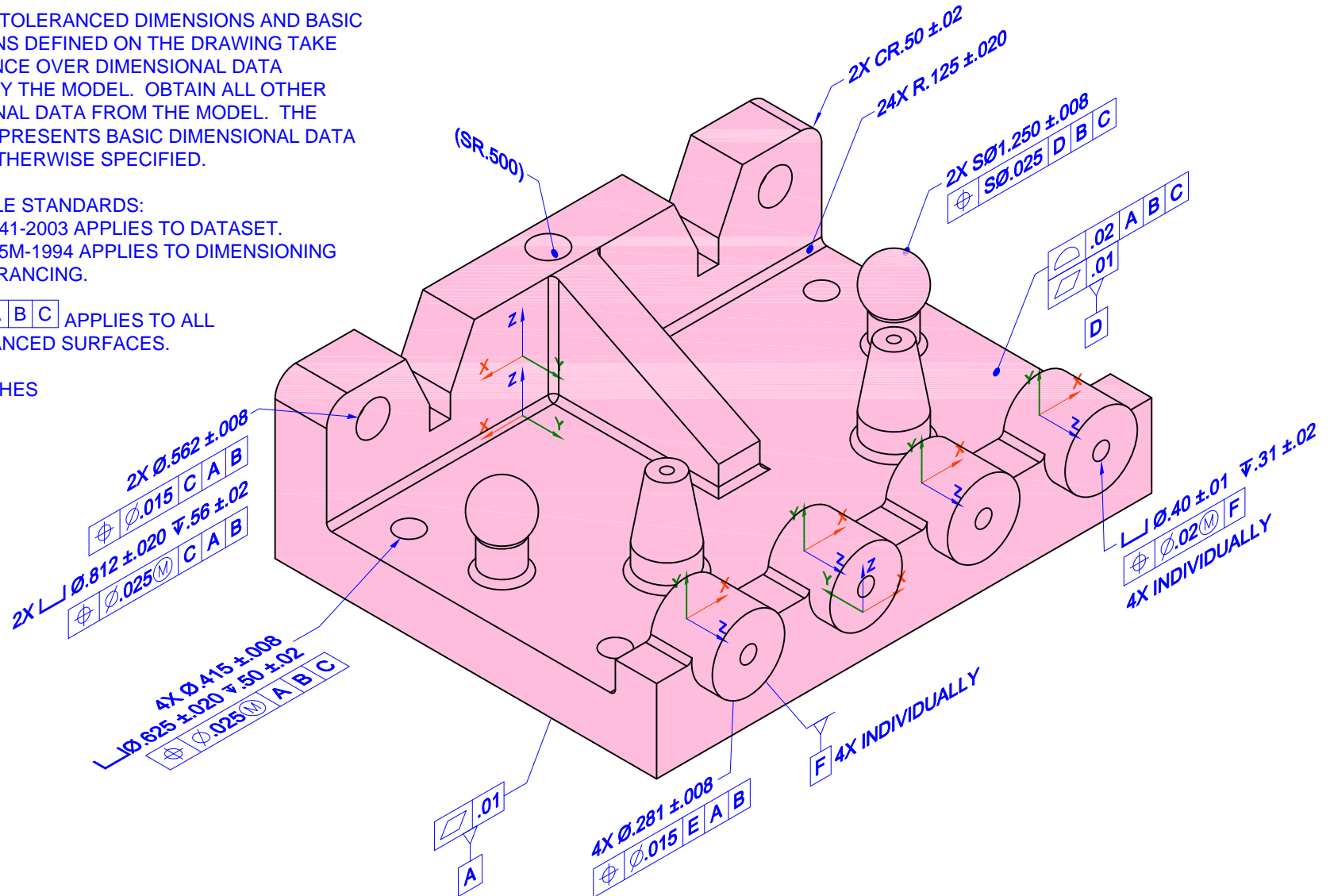

PMI Fully-Toleranced Test Case 6 - View A
Includes Atomic Test Cases - 52, 53, 72, 87, 88, 89

NIST PMI Test Models - 2014

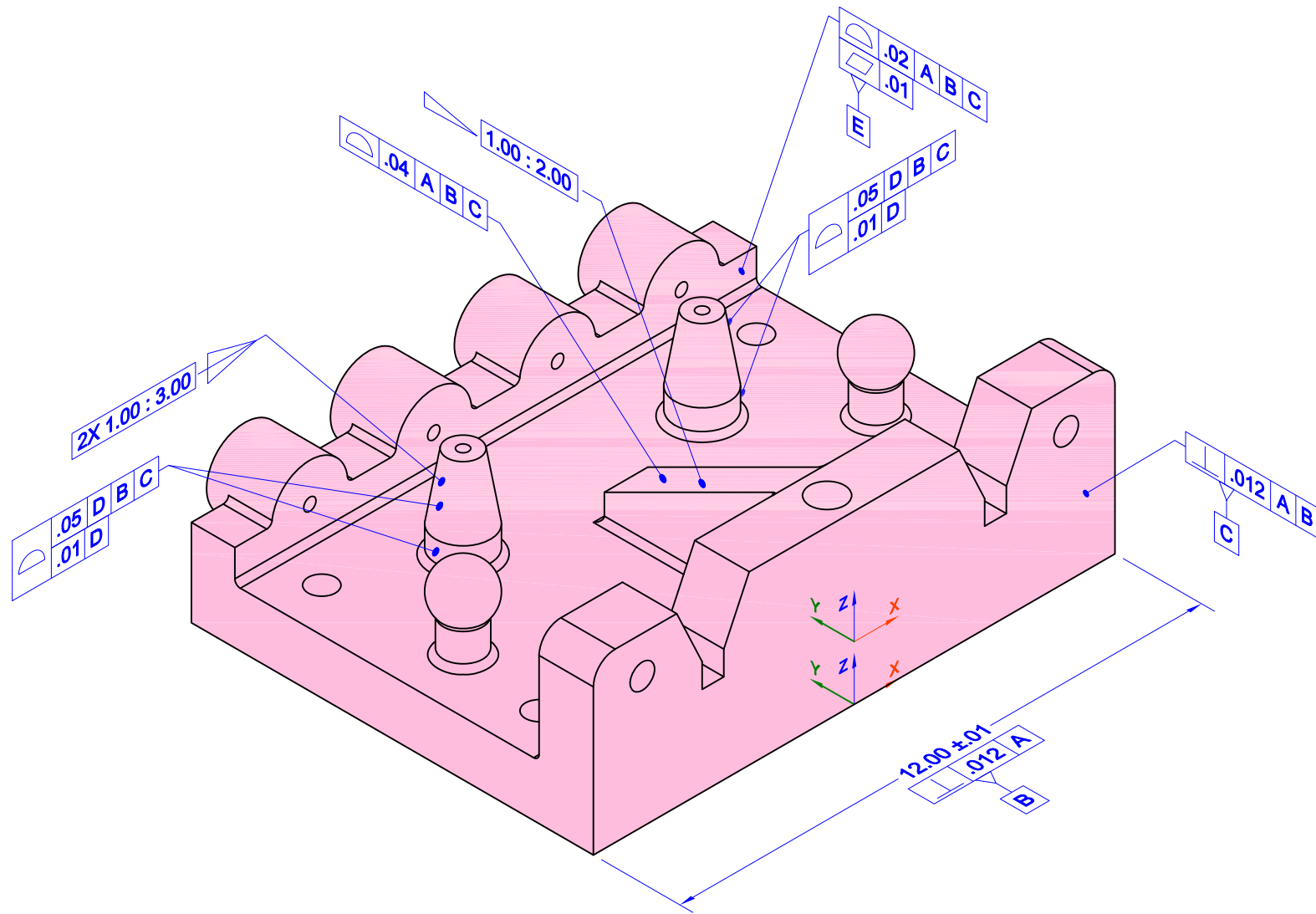

PMI Fully-Toleranced Test Case 6 - View B
Includes Atomic Test Cases - 57, 58

NIST PMI Test Models - 2014

View Rotated 45°

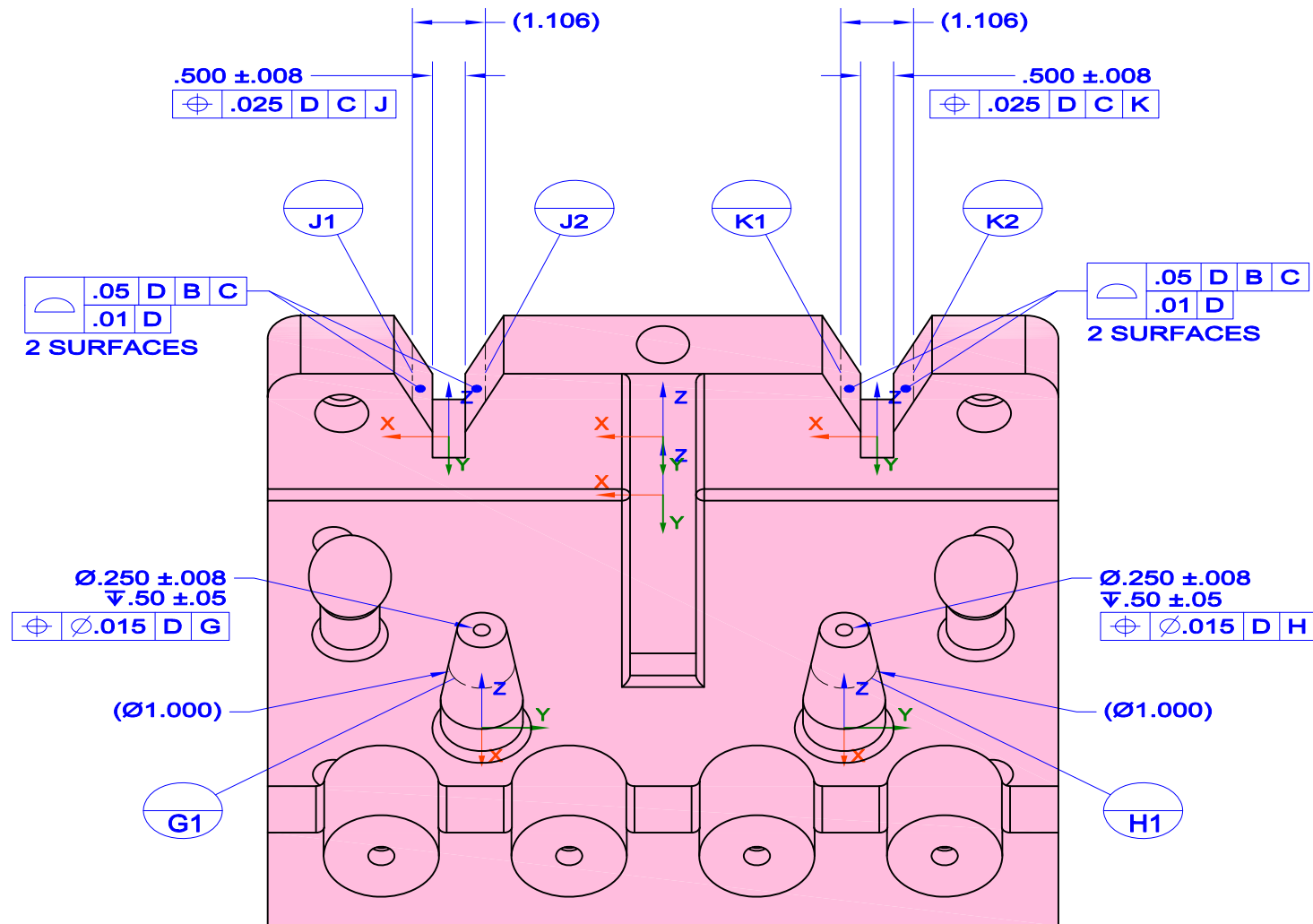

PMI Fully-Toleranced Test Case 6 - View C
Includes Atomic Test Cases - 73, 80

Rev D