

NIST PMI Test Models - 2014

NOTES (UNLESS OTHERWISE SPECIFIED):

- CAD MODEL _____ REV. __ IS REQUIRED TO COMPLETE PRODUCT DEFINITION.
- DIRECTLY-TOLERANCED DIMENSIONS AND BASIC DIMENSIONS DEFINED ON THE DRAWING TAKE PRECEDENCE OVER DIMENSIONAL DATA DEFINED BY THE MODEL. OBTAIN ALL OTHER DIMENSIONAL DATA FROM THE MODEL. THE MODEL REPRESENTS BASIC DIMENSIONAL DATA UNLESS OTHERWISE SPECIFIED.
- APPLICABLE STANDARDS:
ASME Y14.41-2003 APPLIES TO DATASET AND MOVABLE DATUM TARGETS.

ASME Y14.5M-1994 APPLIES TO DIMENSIONING AND TOLERANCING.
- FULL DIAMETER OF EACH INDICATED HOLE MUST INTERSECT WITH THE CROSS-DRILLED HOLE AT ITS BOTTOM. INDICATED HOLES MUST NOT CONTACT FAR SIDE OF CROSS-DRILLED HOLES.
- 1.5 A B C APPLIES TO ALL UNTOLERANCED SURFACES.
- UNITS: MILLIMETERS

Feature and Specification Index
nist_ftc_10_asme1_rb_fsi.pdf

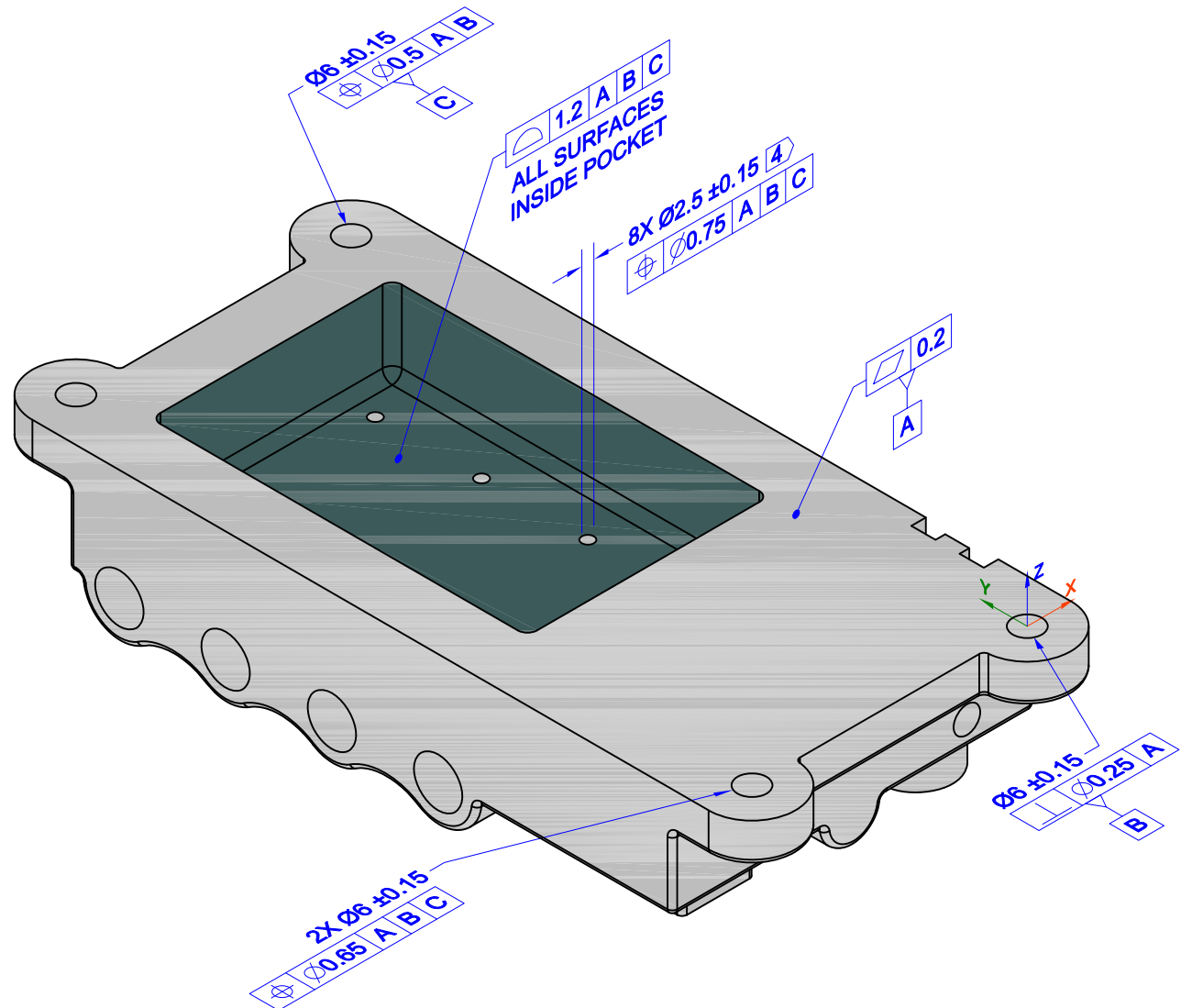

PMI Fully-Toleranced Test Case 10 - View A
Includes Atomic Test Cases - N/A

NIST PMI Test Models - 2014

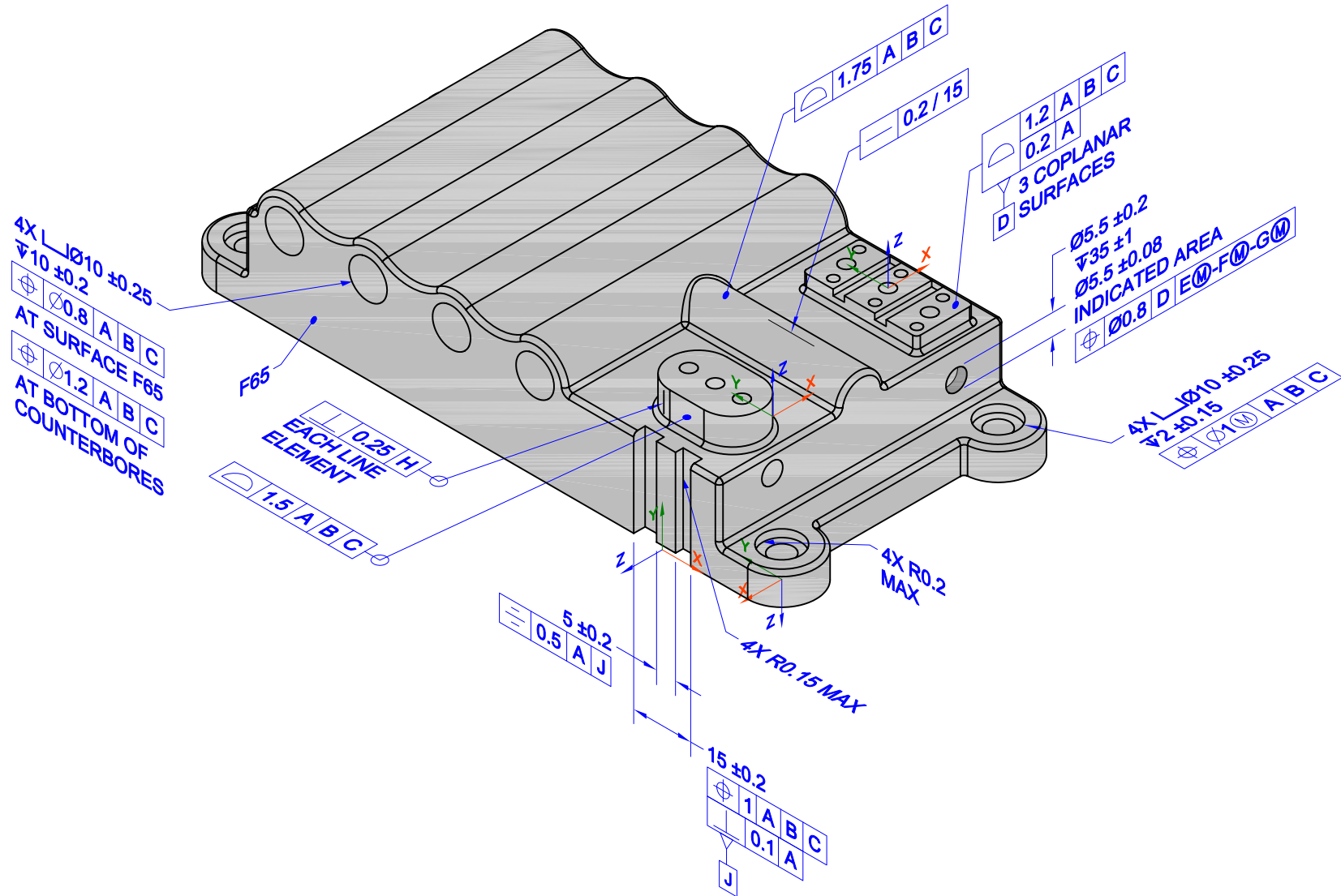

PMI Fully-Toleranced Test Case 10 - View B
Includes Atomic Test Cases - 56, 60, 65, 70, 78, 86, 93

NIST PMI Test Models - 2014

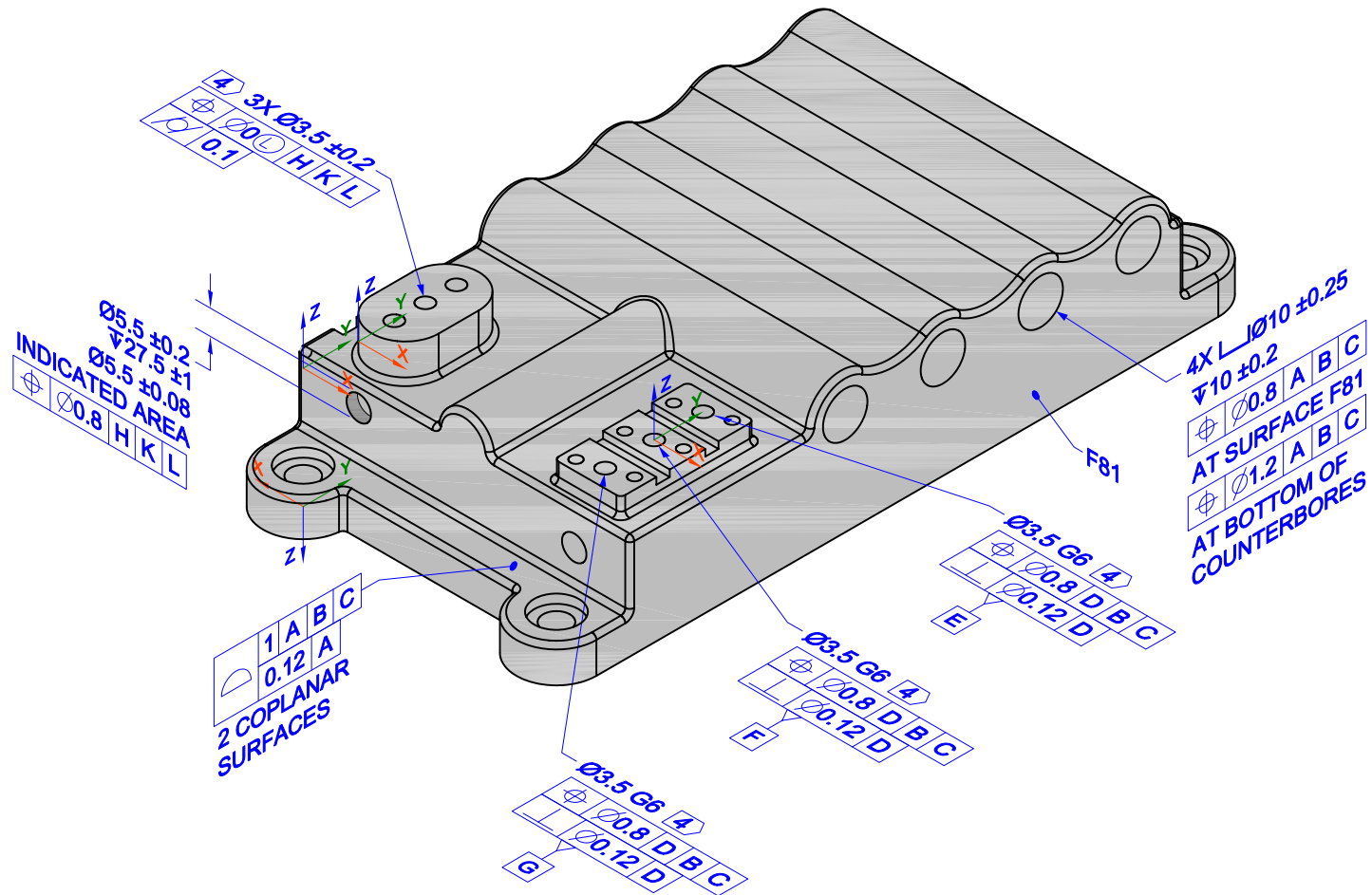

PMI Fully-Toleranced Test Case 10 - View C
 Includes Atomic Test Cases - 51, 56, 63, 86, 91

NIST PMI Test Models - 2014

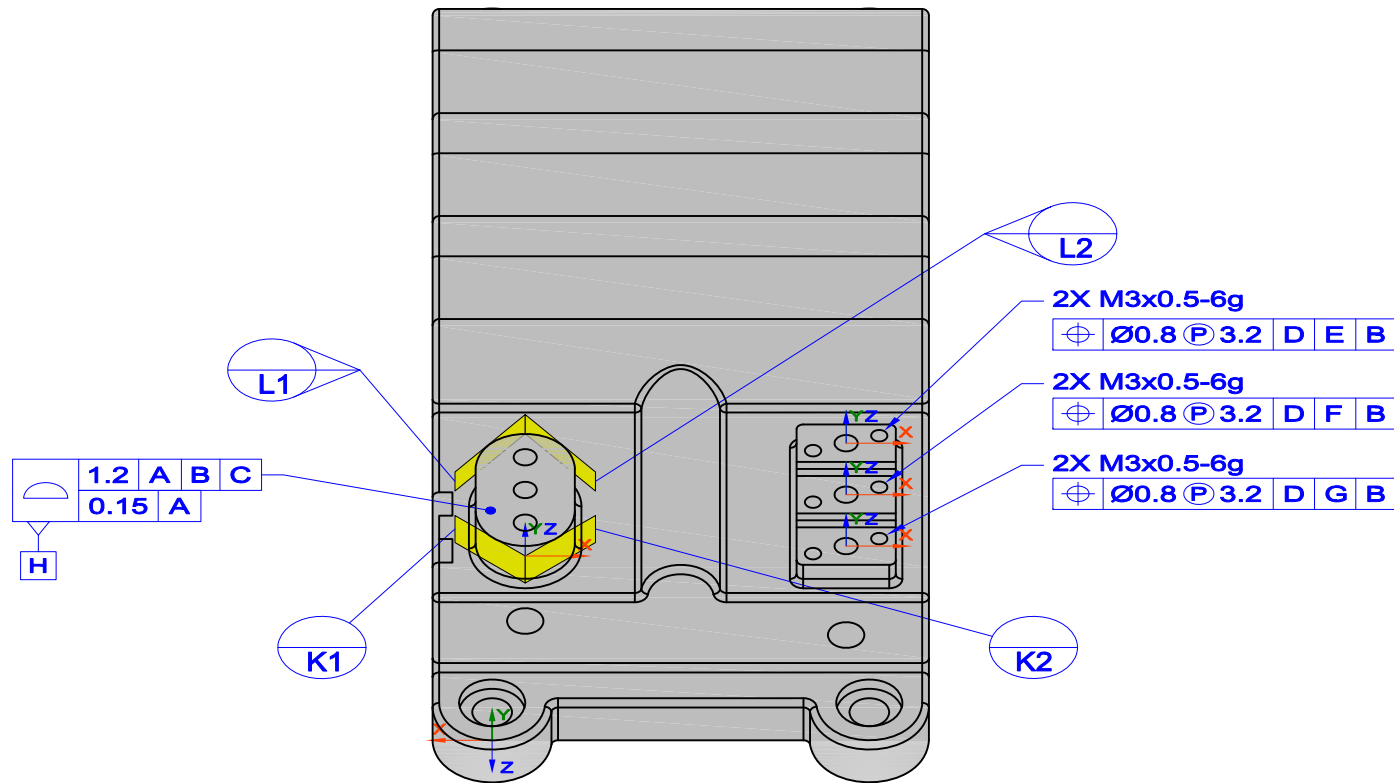

PMI Fully-Toleranced Test Case 10 - View D
 Includes Atomic Test Cases - 79

NIST PMI Test Models - 2014

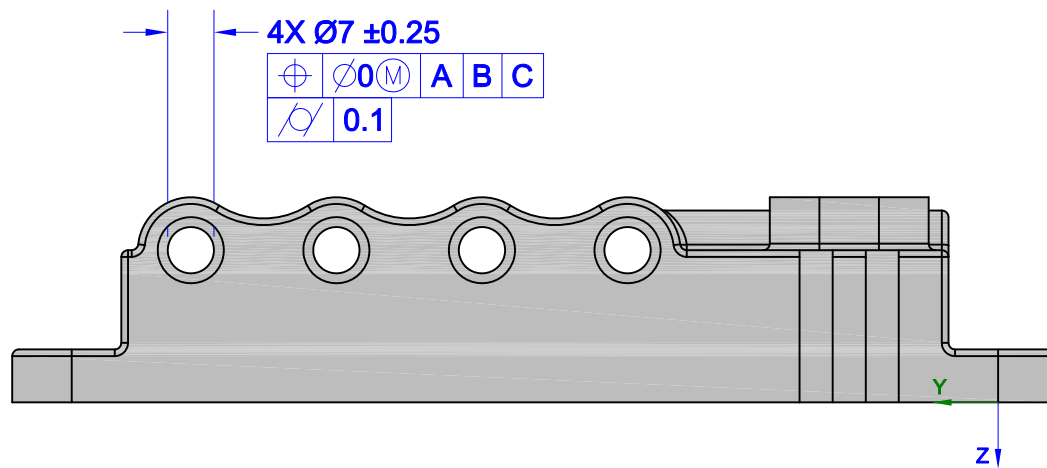

PMI Fully-Toleranced Test Case 10 - View E
Includes Atomic Test Cases - 63, 91

Rev B

nist_ftc_10_asme1_rb