

SEQUENCE NOTES

1. THE FOLLOWING CONSTRUCTION SEQUENCE LISTS THE REQUIRED ORDER OF STEPS TO BE COMPLETED TO ACHIEVE THE WATER MANAGEMENT AND AIRTIGHTNESS GOALS OF THIS PROJECT. IT IS THE RESPONSIBILITY OF THE GENERAL CONTRACTOR TO COORDINATE AND SCHEDULE ALL CONSTRUCTION ACTIVITIES TO ACCOMMODATE THIS CONSTRUCTION SEQUENCE.
2. GARAGE AND BREEZEWAY CONSTRUCTION TO FOLLOW THIS CONSTRUCTION SEQUENCE AS APPLICABLE. HOWEVER, GARAGE AND BREEZEWAY ARE PERMITTED TO BE CONSTRUCTED AFTER HOUSE CONSTRUCTION HAS BEGUN AS LONG AS THE FOLLOWING STEPS ARE COMPLETED: 1) BREEZEWAY CONCRETE SLAB AT HOUSE TO BE INSTALLED AT STEP 15 ALONG WITH PORCH CONCRETE SLABS OR LATER, AND 2) BREEZEWAY ROOF LEDGER FRAMING TO BE INSTALLED AT STEP 16, ON TOP OF INSULATING SHEATHING AND BEFORE FURRING STRIPS. NOTE: AIRTIGHTNESS PERFORMANCE TESTS NOT PERFORMED ON GARAGE.
3. ALL CONCRETE SLAB AND CONCRETE FOUNDATION WALL PENETRATIONS MUST BE CAST INTO THE CONCRETE. PENETRATIONS SHALL NOT BE CREATED AFTER THE CONCRETE HAS BEEN PLACED. SEE A-603 FOR PENETRATION SCHEDULE.
4. ALL EXTERIOR WALL AND ROOF PENETRATIONS MUST BE INSTALLED DIRECTLY AFTER THE AIR BARRIER MEMBRANE HAS BEEN INSTALLED. PENETRATIONS SHALL NOT BE INSTALLED AFTER THE INSULATING SHEATHING HAS BEEN INSTALLED. SEE A-603 FOR PENETRATION SCHEDULE.

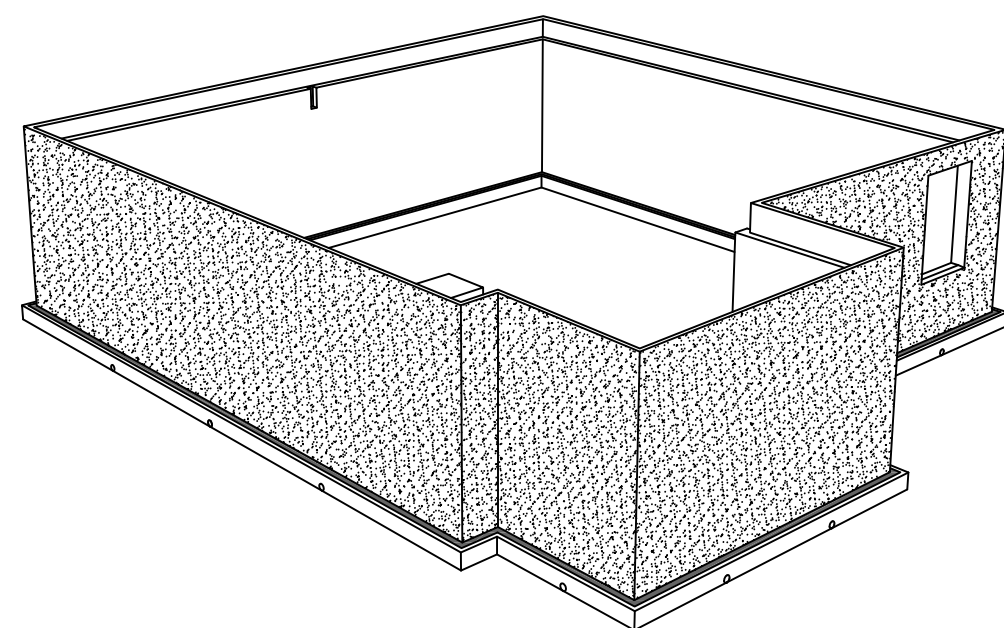

STEP 1

1. CAST PVC DRAIN PIPE INTO BOTTOM OF CONCRETE FOOTING. CONCRETE COLUMN FOOTINGS TO BE PLACED AT SAME TIME AS FOUNDATION WALL FOOTINGS.
- NOTE: FOOTING PENETRATIONS SHOWN AS EXAMPLE ONLY. NOT ALL SHOWN. SEE A-102 FOR PIPE LOCATIONS.
2. APPLY CAPILLARY BREAK ON TOP OF FOOTING.
3. CAST PENETRATIONS, OPENINGS AND BEAM POCKETS INTO CONCRETE FOUNDATION WALL (SEE A-603 FOR PENETRATION SCHEDULE). (NOT SHOWN IN GRAPHIC). SEE A-506 FOR FOUNDATION PENETRATION DETAILS.
4. SEAL FOUNDATION WALL PENETRATIONS TO CONCRETE ON BOTH INTERIOR AND EXTERIOR FACE OF WALL. (NOT SHOWN IN GRAPHIC). SEE A-506 FOR FOUNDATION DETAILS.
5. APPLY DAMPROOFING TO CONCRETE FOUNDATION WALL.

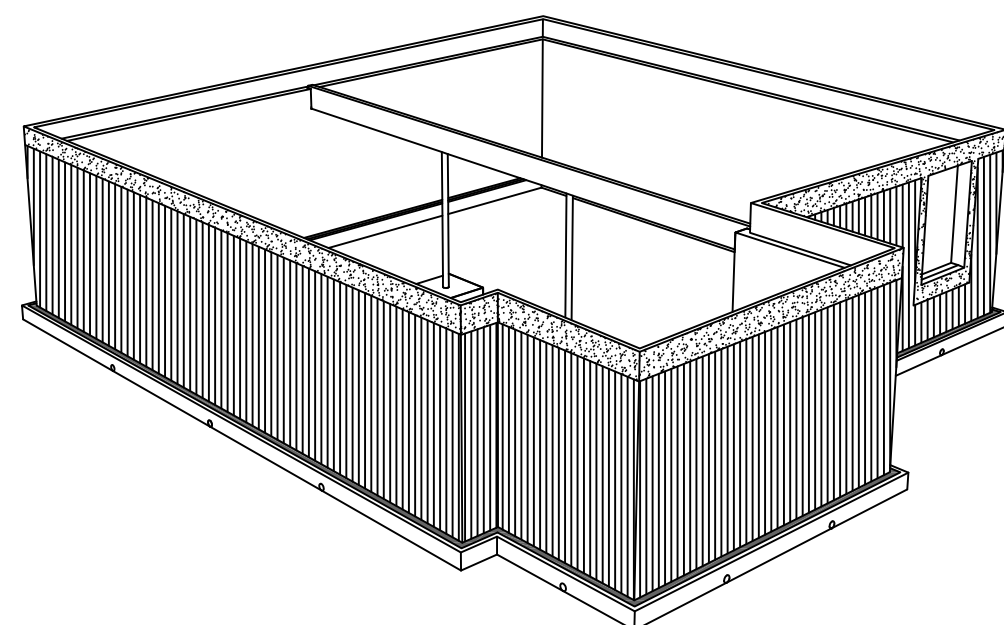
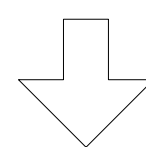

STEP 2

1. INSTALL GEOCOMPOSITE DRAINAGE SYSTEM FROM TOP OF FOOTING TO APPROX. 1'-6" BELOW TOP OF FOUNDATION WALL.
2. INSTALL PERIMETER DRAIN SYSTEM:
  - a. POSITION FILTER FABRIC AT BASE OF FOOTING AROUND PERIMETER OF FOUNDATION. (NOT SHOWN IN GRAPHIC)
  - b. INSTALL PERIMETER DRAINAGE SYSTEM. (NOT SHOWN IN GRAPHIC)
  - c. PLACE GRAVEL DRAINAGE BED AROUND PERIMETER PIPES. (NOT SHOWN IN GRAPHIC)
  - d. WRAP FILTER FABRIC AROUND GRAVEL DRAINAGE BED. (NOT SHOWN IN GRAPHIC)
6. BACKFILL FROM TOP OF FOOTING TO 3'-0" BELOW TOP OF FOUNDATION WALL USING FREE-DRAINING BACKFILL AS SPECIFIED. (NOT SHOWN IN GRAPHIC)

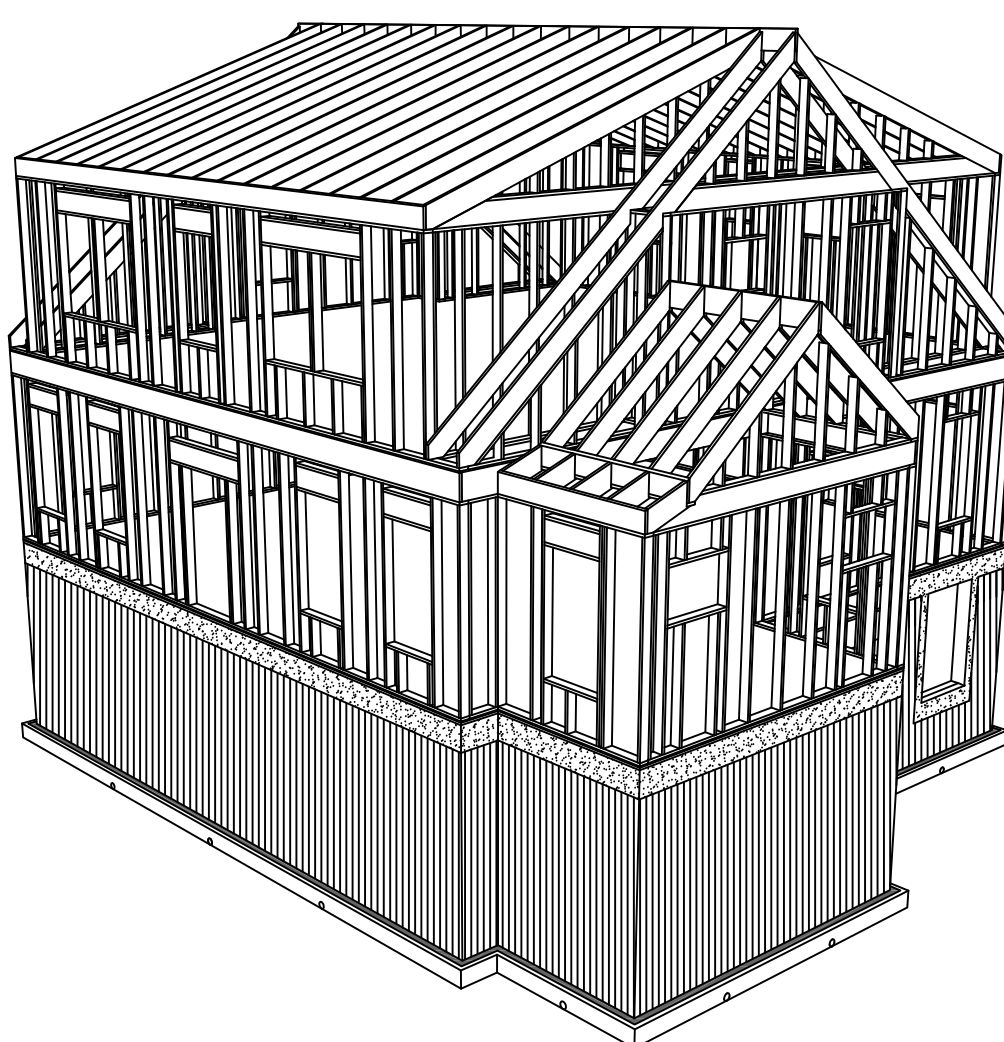
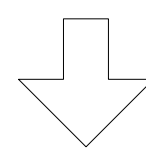

STEP 3

1. FRAME HOUSE ACCORDING TO FRAMING PLANS AND WALL FRAMING ELEVATIONS.
- NOTE: FRAMING IN GRAPHIC SHOWN FOR SEQUENCE PURPOSES ONLY. SEE FRAMING PLANS AND WALL FRAMING ELEVATIONS FOR FRAMING LAYOUT.
2. CAST ALL PENETRATIONS (SEE A-603 FOR PENETRATION SCHEDULE) INTO BASEMENT CONCRETE SLAB AND SEAL TO CONCRETE WITH URETHANE SEALANT. (NOT SHOWN IN GRAPHIC). SEE A-506 FOR FOUNDATION DETAILS.
3. SEAL BASEMENT CONCRETE SLAB TO PERIMETER XPS INSULATING SHEATHING WITH URETHANE SEALANT. SEAL TOP OF PERIMETER XPS INSULATING SHEATHING TO CONCRETE FOUNDATION WALL WITH URETHANE SEALANT. (NOT SHOWN IN GRAPHIC)

↑  
PROCEED TO  
STEP 4 ABOVE

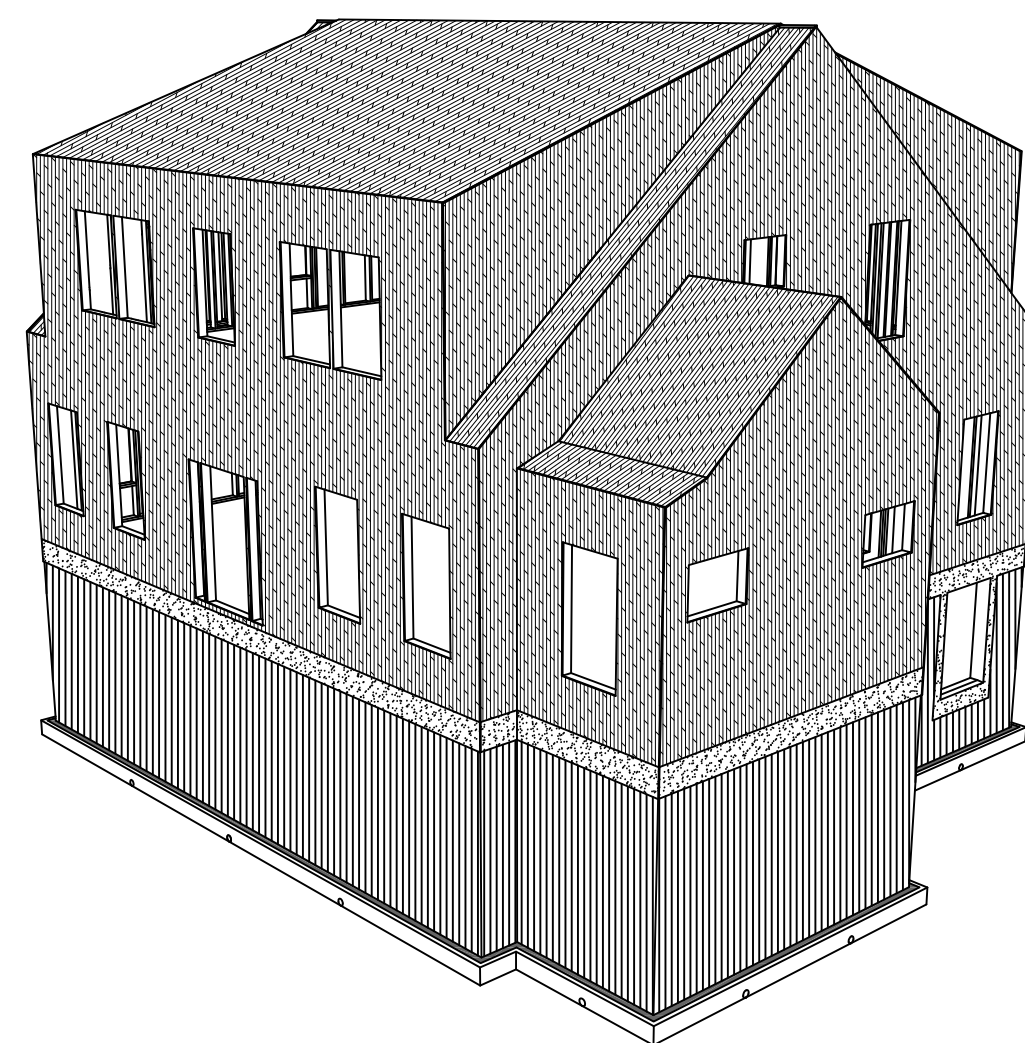

STEP 4

1. INSTALL 1/2" PLYWOOD SHEATHING ON EXTERIOR WALLS.
  2. INSTALL 1/2" PLYWOOD SHEATHING WITH H-CLIPS ON ROOF.
- NOTE: DO NOT EXTEND PLYWOOD SHEATHING BEYOND ROOF PLANE AT ROOF-TO-WALL INTERSECTIONS.

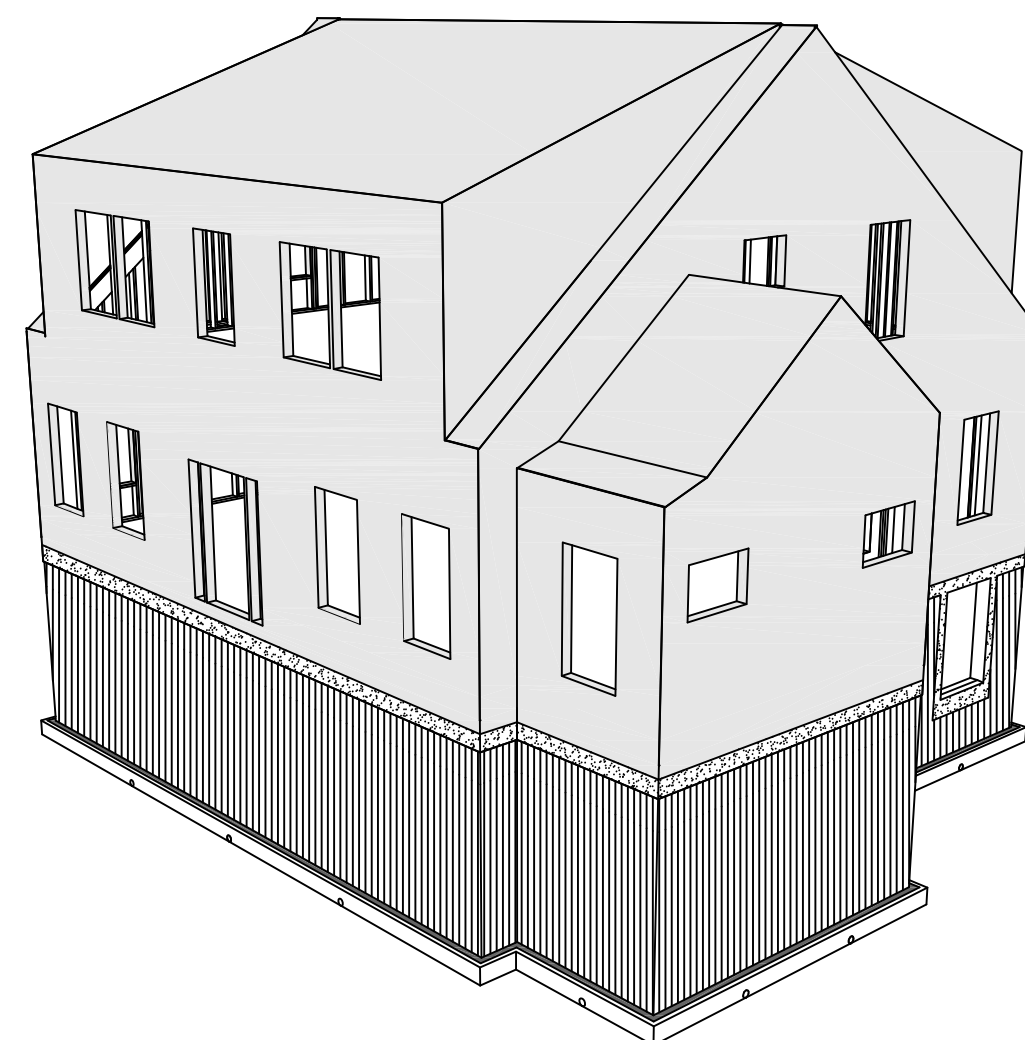
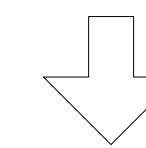

STEP 5

1. INSTALL CONTINUOUS FULLY-ADHERED AIR BARRIER MEMBRANE OVER 1/2" PLYWOOD SHEATHING ON WALLS AND ROOF. OVERLAP MEMBRANE ON ROOF OVER MEMBRANE ON WALL TO ENSURE AIRTIGHT CONNECTION. EXTEND MEMBRANE APPROX. 6" PAST BOTTOM OF PLYWOOD SHEATHING ON WALL ONTO CONCRETE FOUNDATION WALL. EXTEND 5 1/2" INTO WINDOW AND DOOR ROUGH OPENINGS.
2. SEAL 4 CORNERS OF WOOD FRAMED ROUGH OPENINGS FOR ALL WINDOWS AND DOORS WITH URETHANE SEALANT.

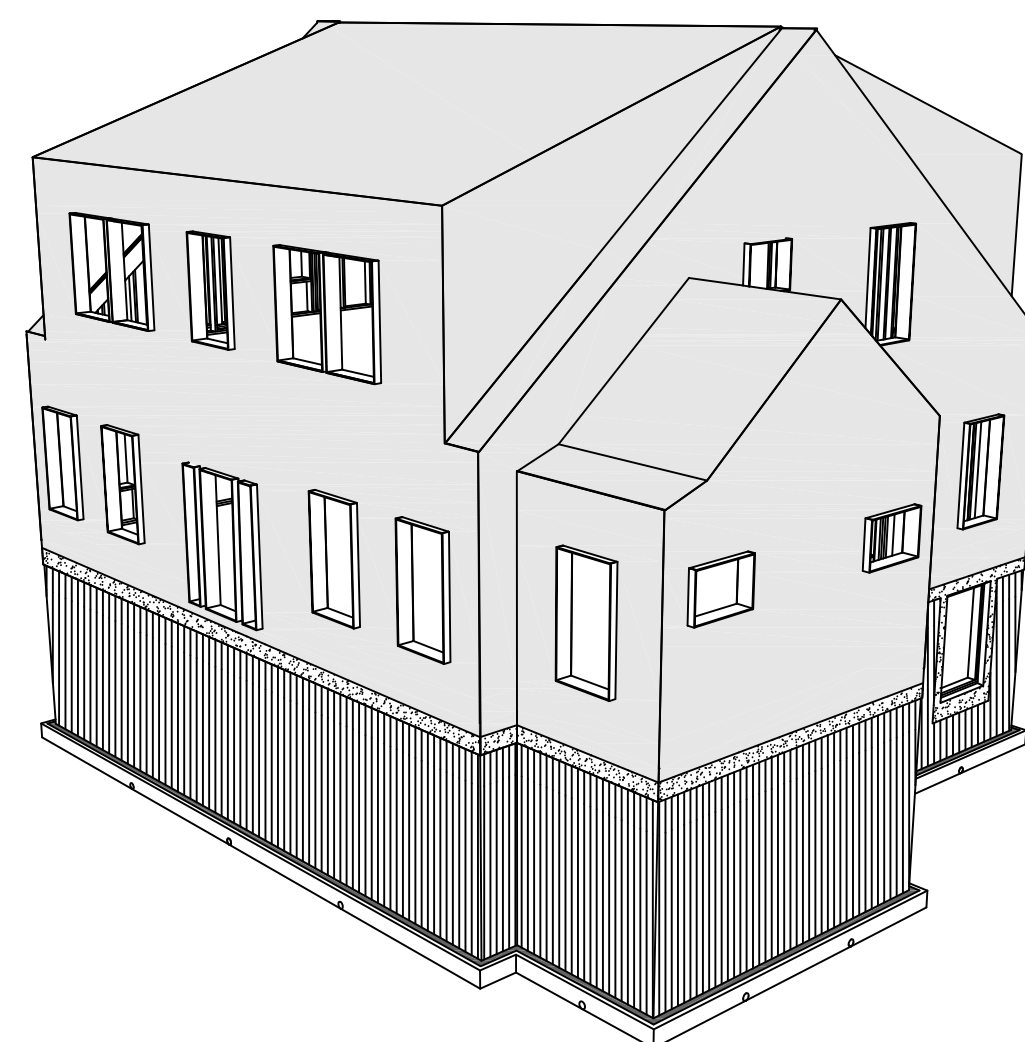
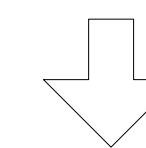

STEP 6

1. INSTALL PRE-ASSEMBLED 1/2" PLYWOOD EXTENSION BOX AT ALL WINDOW AND DOOR ROUGH OPENINGS. COAT ALL SURFACES OF PLYWOOD BOX WITH LIQUID-APPLIED VAPOR PERMEABLE WATERPROOFING COATING PRIOR TO BOX CONSTRUCTION AND INSTALLATION. SEAL INTERIOR CORNERS WITH URETHANE SEALANT ONCE INSTALLED. INSTALL BASEMENT WINDOW WOOD BUCKS AND SEAL TO CONCRETE. (SEE WINDOW AND DOOR DETAILS AND INSTALLATION SEQUENCES ON A-503, A-504, AND A-506.)
2. SEAL ALL PLYWOOD BOXES TO AIR BARRIER MEMBRANE ON EXTERIOR OF HOUSE WITH URETHANE SEALANT AT PERIMETER OF PLYWOOD BOX.
3. SEAL ALL PLYWOOD BOXES TO WOOD FRAMING ON INTERIOR OF HOUSE WITH ACRYLIC LATEX SEALANT AT PERIMETER OF PLYWOOD BOX.
4. INSTALL ALL EXTERIOR WALL AND ROOF PENETRATIONS (SEE A-603 FOR PENETRATION SCHEDULE). SEAL PENETRATIONS TO AIR BARRIER MEMBRANE WITH CLOSED CELL FOAM BACKER ROD AND URETHANE SEALANT ON EXTERIOR AND INTERIOR OF HOUSE. SEE A-505 AND A-509 FOR PENETRATION DETAILS.

STOP  
SEAL PLASTIC SHEET TO INTERIOR SIDE OF PLYWOOD EXTENSION BOX AT ALL WINDOWS AND DOORS, TO INTERIOR SIDE OF ALL FOUNDATION WALL, SLAB, EXTERIOR WALL AND ROOF PENETRATIONS. PERFORM BLOWER DOOR TEST AND AIR SEAL AS REQUIRED TO ACHIEVE AIRTIGHTNESS SPECIFIED IN PERFORMANCE TESTING SECTION OF THE SPECIFICATION.

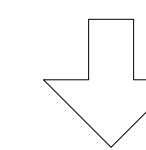

PROCEED TO  
STEP 7 ON A-501B

BUILDING SCIENCE CORPORATION

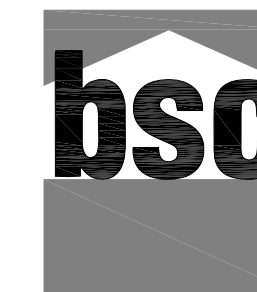

30 FOREST STREET SOMERVILLE, MA  
T: (978) 589-5100 F: (978) 589-5103  
www.buildingscience.com

CONSULTANT:

PROJECT:

National Institute of Standards and Technology

NET ZERO ENERGY  
RESIDENTIAL TEST  
FACILITY

NIST Campus  
Gaithersburg, MD



U.S. DEPARTMENT OF ENERGY | Energy Efficiency & Renewable Energy

MARK	DATE	DESCRIPTION
ISSUE:	03/31/10	ISSUED FOR CONSTRUCTION

PROJECT NO: NIST NZERTF  
CAD DWG FILE: A-PLOT-DETL-NZERTF  
DRAWN BY: HW  
CHECKED BY: BP

COPYRIGHT © 2009  
BUILDING SCIENCE CORPORATION

SHEET TITLE:

REQUIRED  
CONSTRUCTION  
SEQUENCE -  
PART A

SCALE AS NOTED

A-501A

SEE A-501A FOR "SEQUENCE NOTES" AND STEPS 1-6.

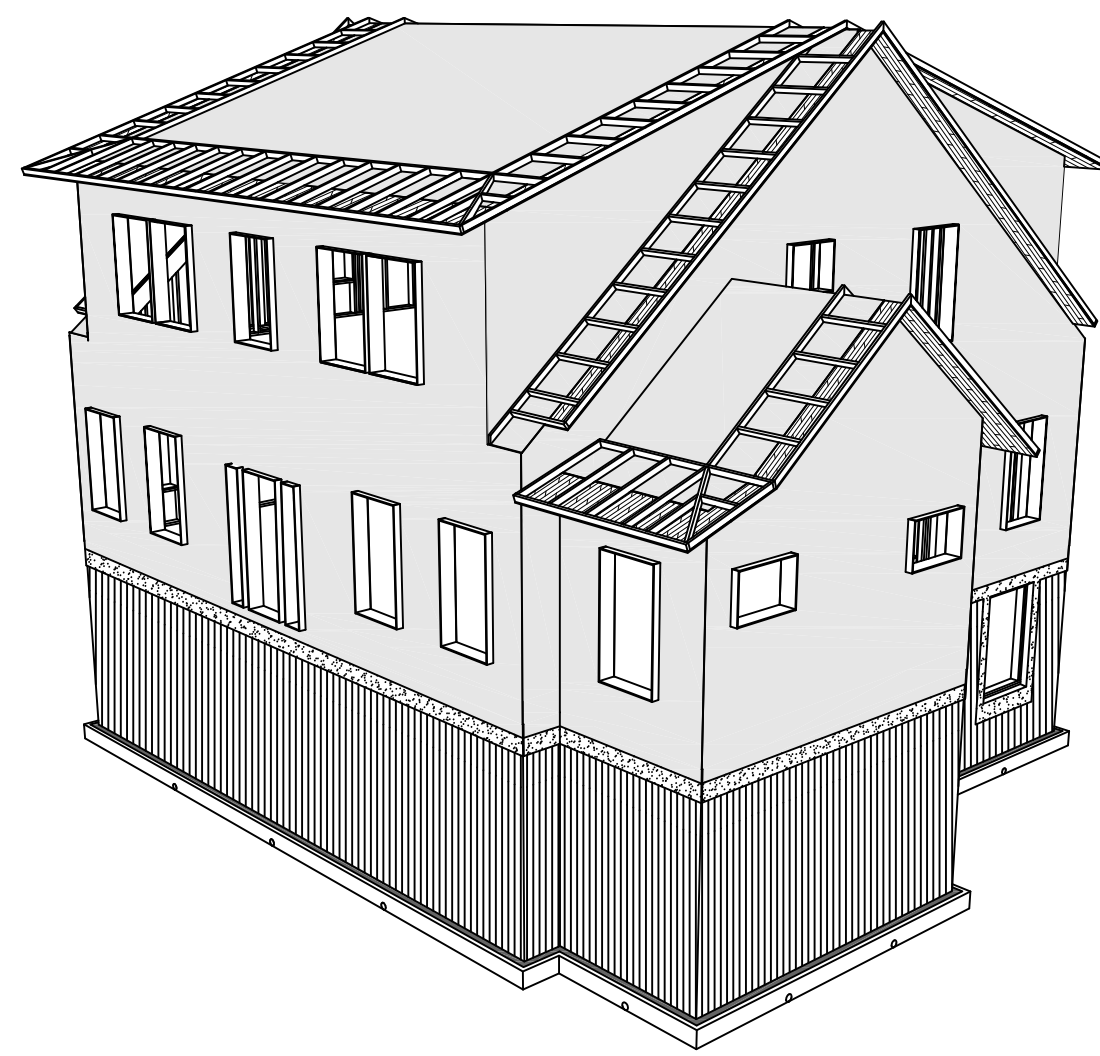

**STEP 7**

1. INSTALL 2x4 ROOF OVERHANG FRAMING ON TOP OF AIR BARRIER MEMBRANE.
2. INSTALL  $\frac{3}{4}$ " PLYWOOD SOFFIT UNDER OVERHANG FRAMING.

NOTE: FRAMING IN GRAPHIC SHOWN FOR SEQUENCE PURPOSES ONLY, SEE LOWER AND UPPER ROOF FRAMING PLANS FOR FRAMING LAYOUT.

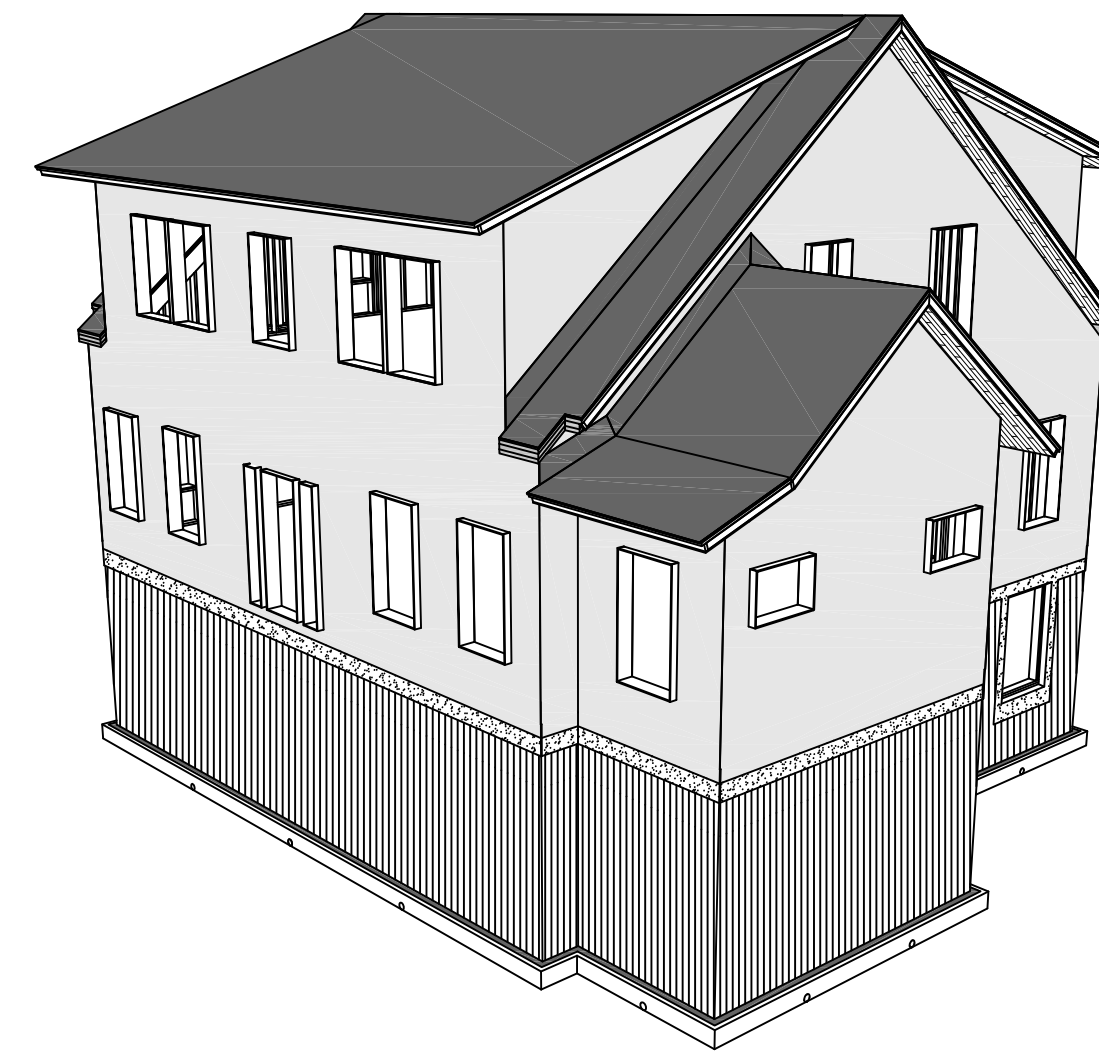
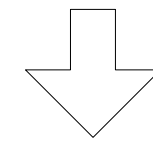

**STEP 10**

1. INSTALL CONTINUOUS FULLY-ADHERED PEEL AND STICK ROOF MEMBRANE (INSTALL MEMBRANE IN 2 STEPS ALONG WITH MEMBRANE FLASHING COLLAR AT ROOF PENETRATIONS - SEE A-509). TURN MEMBRANE UP WALL 12" MIN. AT ROOF TO WALL INTERSECTIONS. TAPE TOP EDGE OF MEMBRANE TO AIR BARRIER MEMBRANE ON WALL.
2. INSTALL MEMBRANE FLASHING COLLAR AT ROOF PENETRATIONS. SEE A-603 FOR PENETRATION SCHEDULE AND A-509 FOR ROOF PENETRATION DETAILS.

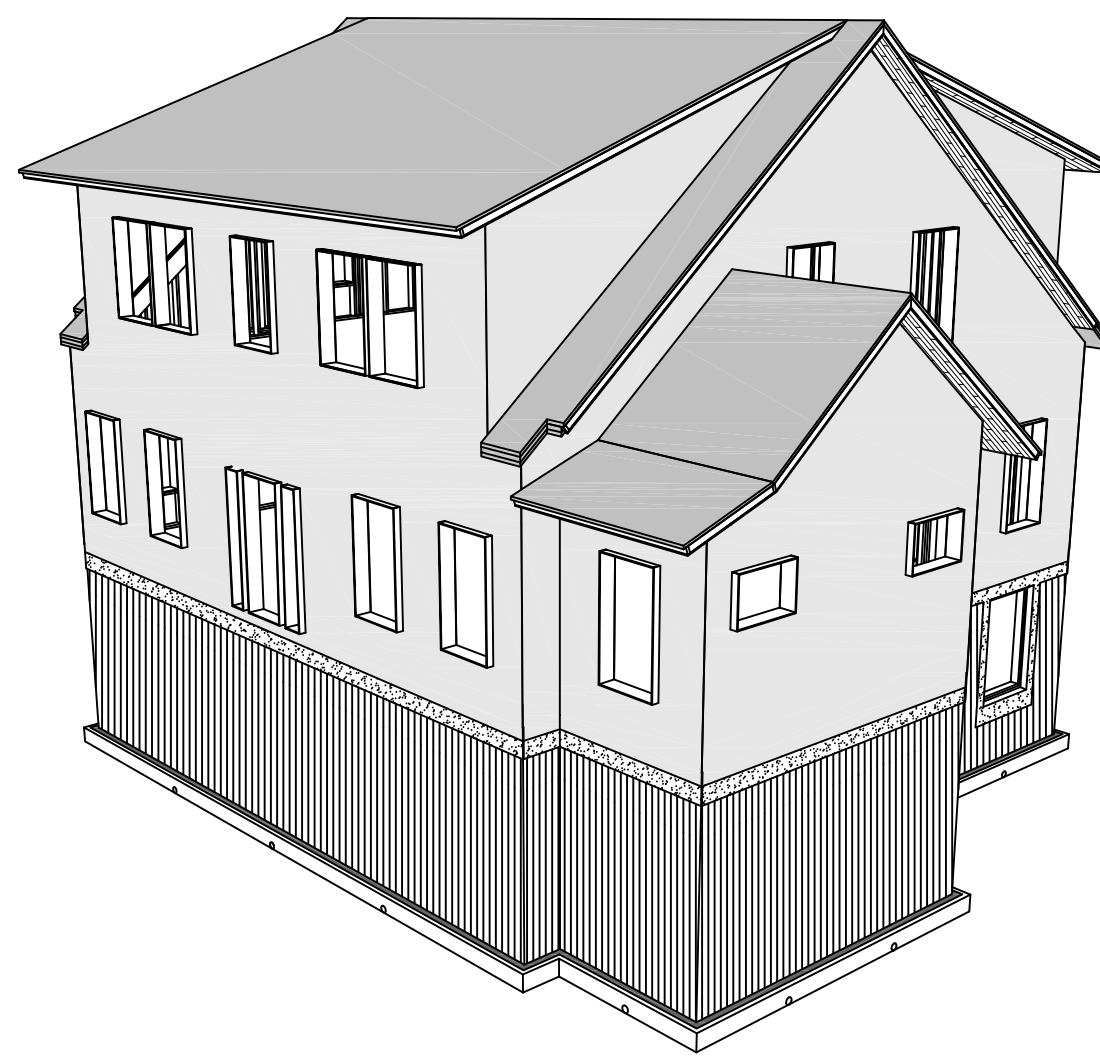
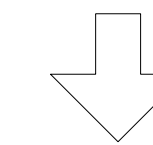

**STEP 8**

1. INSTALL 5" OF FOIL-FACED POLYISOCYANURATE INSULATING SHEATHING IN 3 LAYERS ( $1\frac{1}{2}$ ", 2",  $1\frac{1}{2}$ ") ON ROOF ONLY. STAGGER JOINTS OF INSULATING SHEATHING.
2. SEAL ROOF PENETRATIONS (SEE A-603 FOR PENETRATION SCHEDULE AND A-509 FOR ROOF PENETRATION DETAILS) TO INSULATING SHEATHING WITH CLOSED CELL FOAM BACKER ROD AND URETHANE SEALANT. (NOT SHOWN IN GRAPHIC)

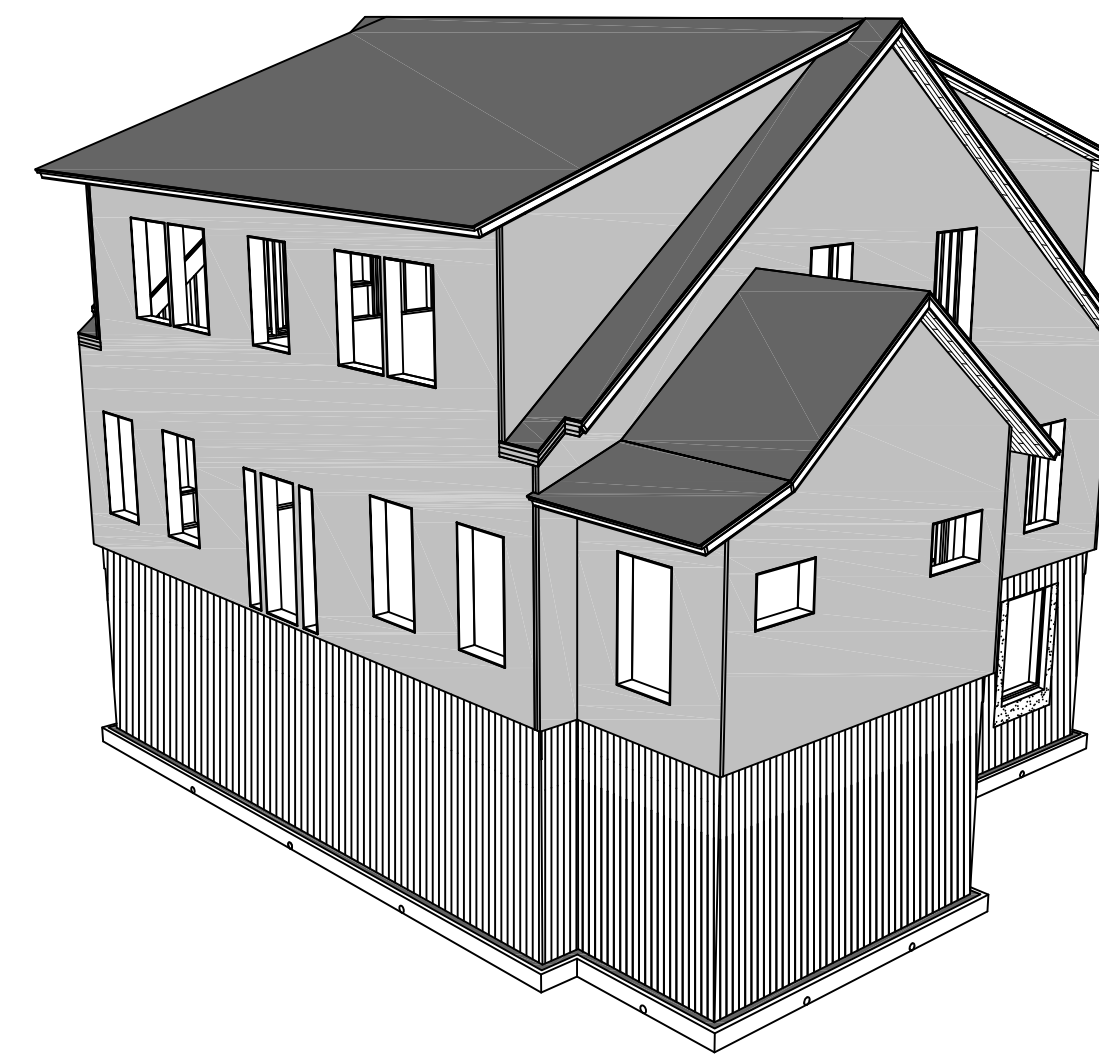
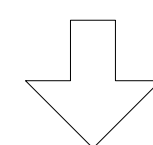

**STEP 11**

1. INSTALL (2) LAYERS OF 2" FOIL-FACED POLYISOCYANURATE INSULATING SHEATHING ON EXTERIOR WALLS. INSTALL INSULATING SHEATHING WITH TEMPORARY FASTENERS (NOT FURRING STRIPS AT THIS STEP) TO ALLOW FOR COMPLETE TAPING OF INSULATING SHEATHING JOINTS. FURRING STRIPS TO BE INSTALLED AFTER WINDOWS AND DOORS HAVE BEEN INSTALLED. STAGGER AND TAPE JOINTS OF INSULATING SHEATHING. OUTER LAYER OF INSULATING SHEATHING IS THE DRAINAGE PLANE. NOTE: FOUNDATION FLASHING (ALUMINUM COIL STOCK) MUST BE ATTACHED BEFORE INSULATING SHEATHING IS INSTALLED AT THE BASE OF THE EXTERIOR WALL (NOT SHOWN IN GRAPHIC).
2. SEAL WALL PENETRATIONS (SEE A-603 FOR PENETRATION SCHEDULE) TO INSULATING SHEATHING WITH CLOSED CELL FOAM BACKER ROD AND URETHANE SEALANT. (NOT SHOWN IN GRAPHIC). SEE A-505 FOR WALL PENETRATION SEALING DETAILS.
3. COMPLETE THE INSTALLATION OF THE GEOCOMPOSITE DRAINAGE SYSTEM, OVERLAPPING FIRST LAYER OF SYSTEM 6" MIN. AND EXTENDING UP TO THE BOTTOM OF INSULATING SHEATHING (BUT UNDER FOUNDATION FLASHING). SEE 3/A-401 FOR TOP OF FOUNDATION DETAIL.

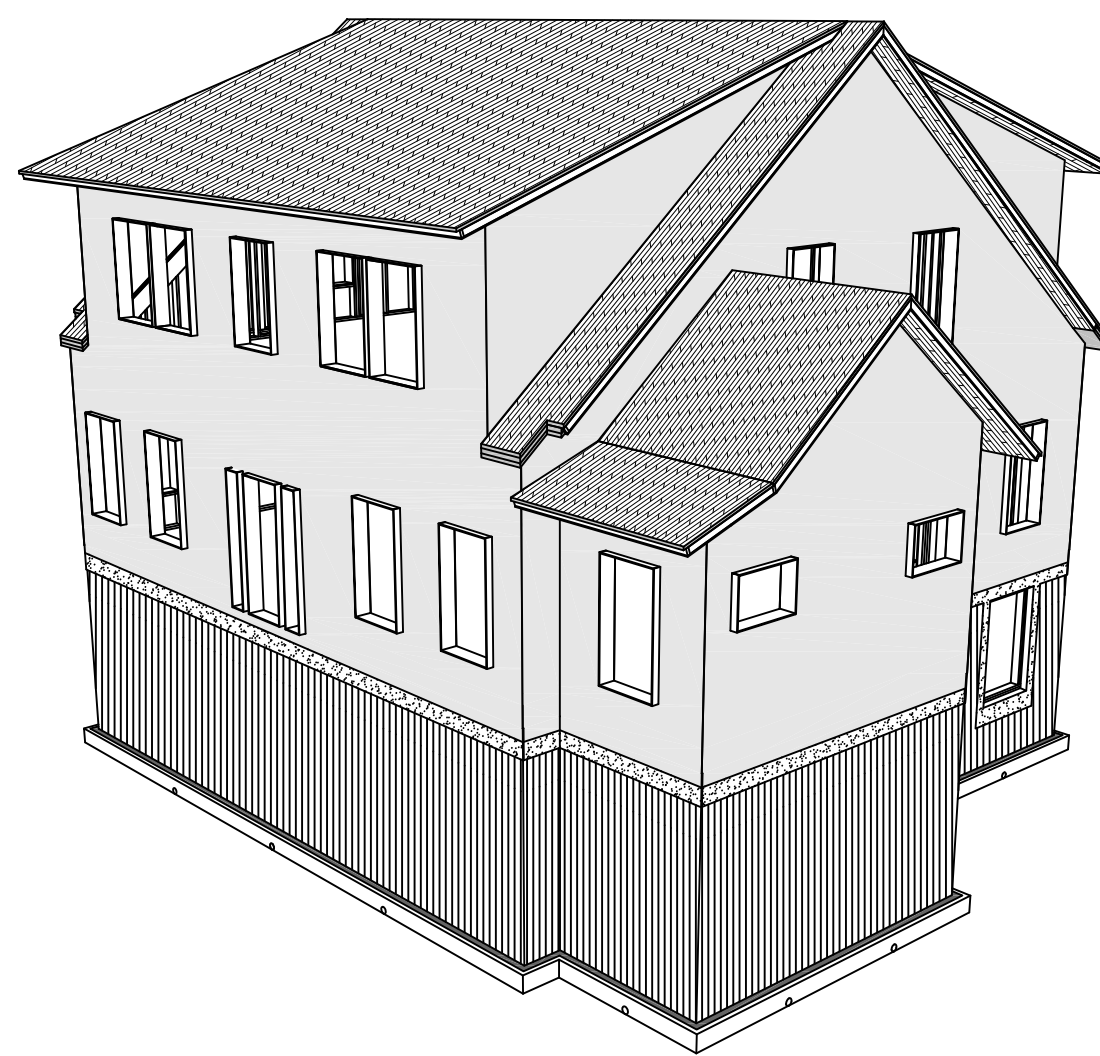
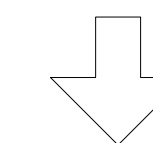

**STEP 9**

1. INSTALL  $\frac{5}{8}$ " PLYWOOD SHEATHING WITH H-CLIPS ON ROOF.

↑  
PROCEED TO  
STEP 10 ABOVE

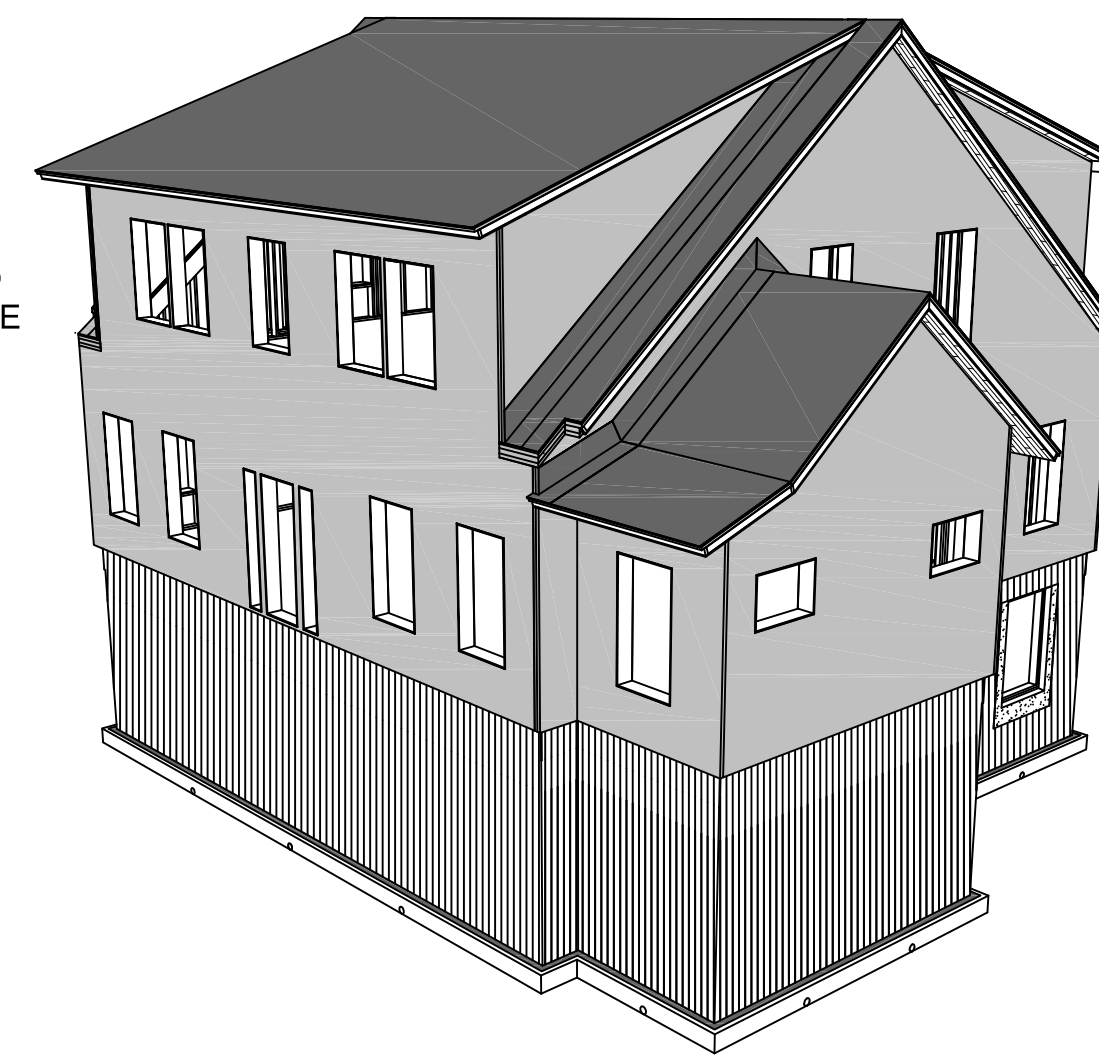

**STEP 12**

1. INSTALL A STRIP OF PEEL-AND-STICK ROOF MEMBRANE AT ROOF-TO-WALL INTERSECTIONS. TURN MEMBRANE UP WALL 12" MIN. AND EXTEND 12" MIN. ACROSS ROOF. TAPE TOP EDGE OF MEMBRANE TO INSULATING SHEATHING ON WALL.

↓  
PROCEED TO  
STEP 13 ON A-501C

**BUILDING SCIENCE CORPORATION**

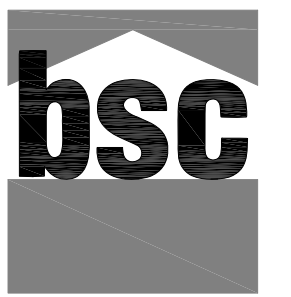

30 FOREST STREET SOMERVILLE, MA  
T: (978) 589-5100 F: (978) 589-5103  
www.buildingscience.com

CONSULTANT:

PROJECT:

National Institute of Standards and Technology

**NET ZERO ENERGY RESIDENTIAL TEST FACILITY**

NIST Campus  
Gaithersburg, MD



U.S. DEPARTMENT OF ENERGY | Energy Efficiency & Renewable Energy

MARK	DATE	DESCRIPTION
ISSUE:	03/31/10	ISSUED FOR CONSTRUCTION

PROJECT NO: NIST NZERTF  
CAD DWG FILE: A-PLOT-DETL-NZERTF  
DRAWN BY: HW  
CHECKED BY: BP

COPYRIGHT © 2009  
BUILDING SCIENCE CORPORATION

SHEET TITLE:

**REQUIRED CONSTRUCTION SEQUENCE - PART B**

SCALE AS NOTED



**A-501B**



SEE A-501A FOR "SEQUENCE NOTES" AND STEPS 1-6, AND A-501B FOR STEPS 7-12.

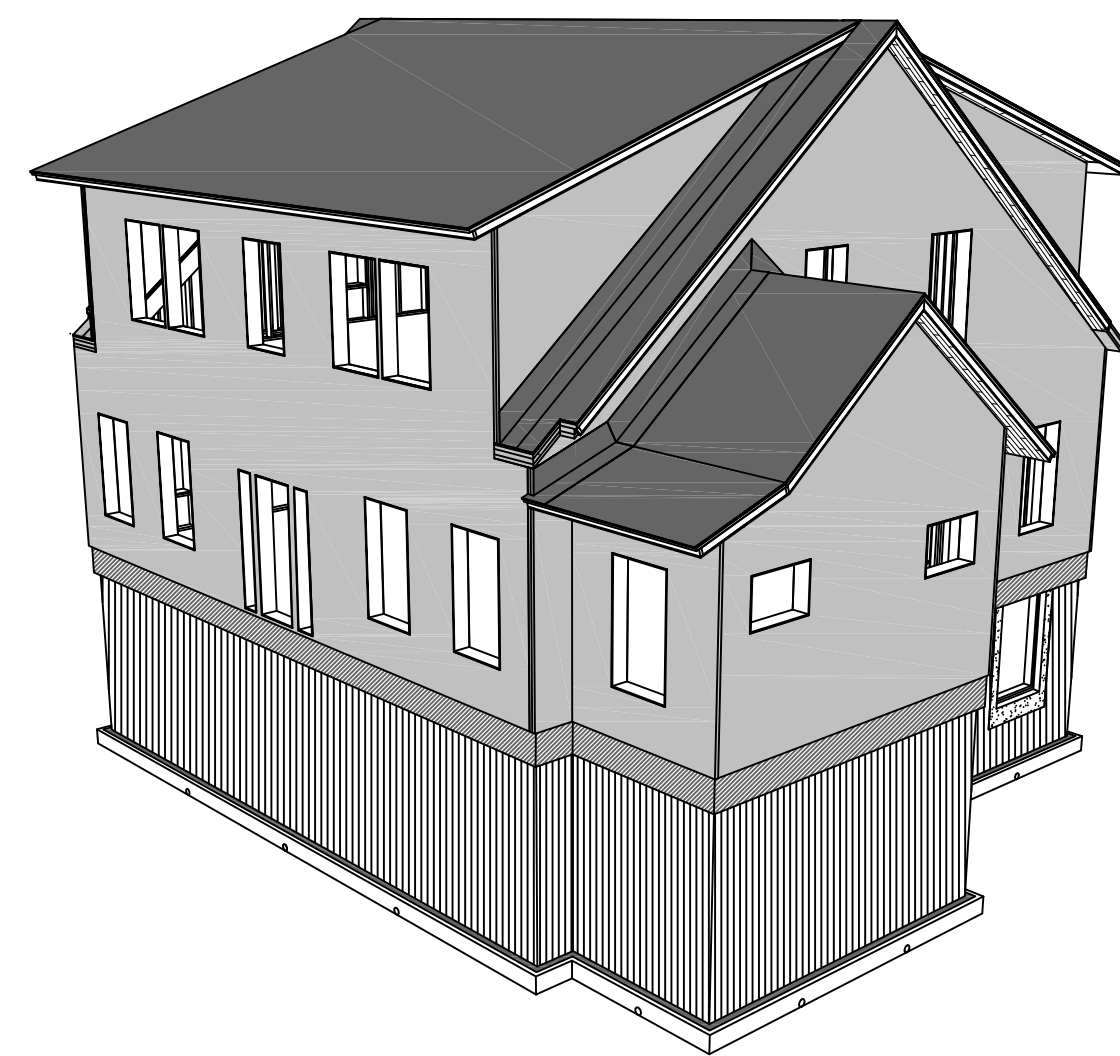

**STEP 13**

1. INSTALL MINERAL WOOL INSULATION COVERED WITH CEMENTITIOUS BOARD AROUND HOUSE PERIMETER AT TOP OF FOUNDATION WALL - FROM INSULATING SHEATHING DOWN 2'-0". NOTE: DOOR SILL FLASHING AND THRESHOLD BLOCKING NEED TO BE INSTALLED BEFORE THIS STEP (SEE A-504 FOR DOOR INSTALLATION SEQUENCE.)
2. INSTALL WINDOW WELL AT BASEMENT WINDOW. (NOT SHOWN IN GRAPHIC). SEE A-506 FOR WINDOW WELL DETAIL.
3. INSTALL REMAINING BACKFILL. (NOT SHOWN IN GRAPHIC)

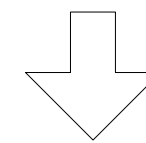

**STEP 16**

1. INSTALL BOTH FRONT PORCH AND REAR SCREEN PORCH FRAMING. (REAR SCREEN PORCH NOT SHOWN IN GRAPHIC)
  2. INTEGRATE PORCH ROOF AND WALL FULLY-ADHERED MEMBRANE WITH HOUSE ROOF AND WALL FULLY-ADHERED MEMBRANE. PORCH ROOF SHEATHING, WALL SHEATHING AND FULLY-ADHERED MEMBRANES NOT SHOWN IN GRAPHIC.
- NOTE: FRAMING IN GRAPHIC SHOWN FOR SEQUENCE PURPOSES ONLY. SEE PORCH FRAMING PLANS FOR FRAMING LAYOUT.

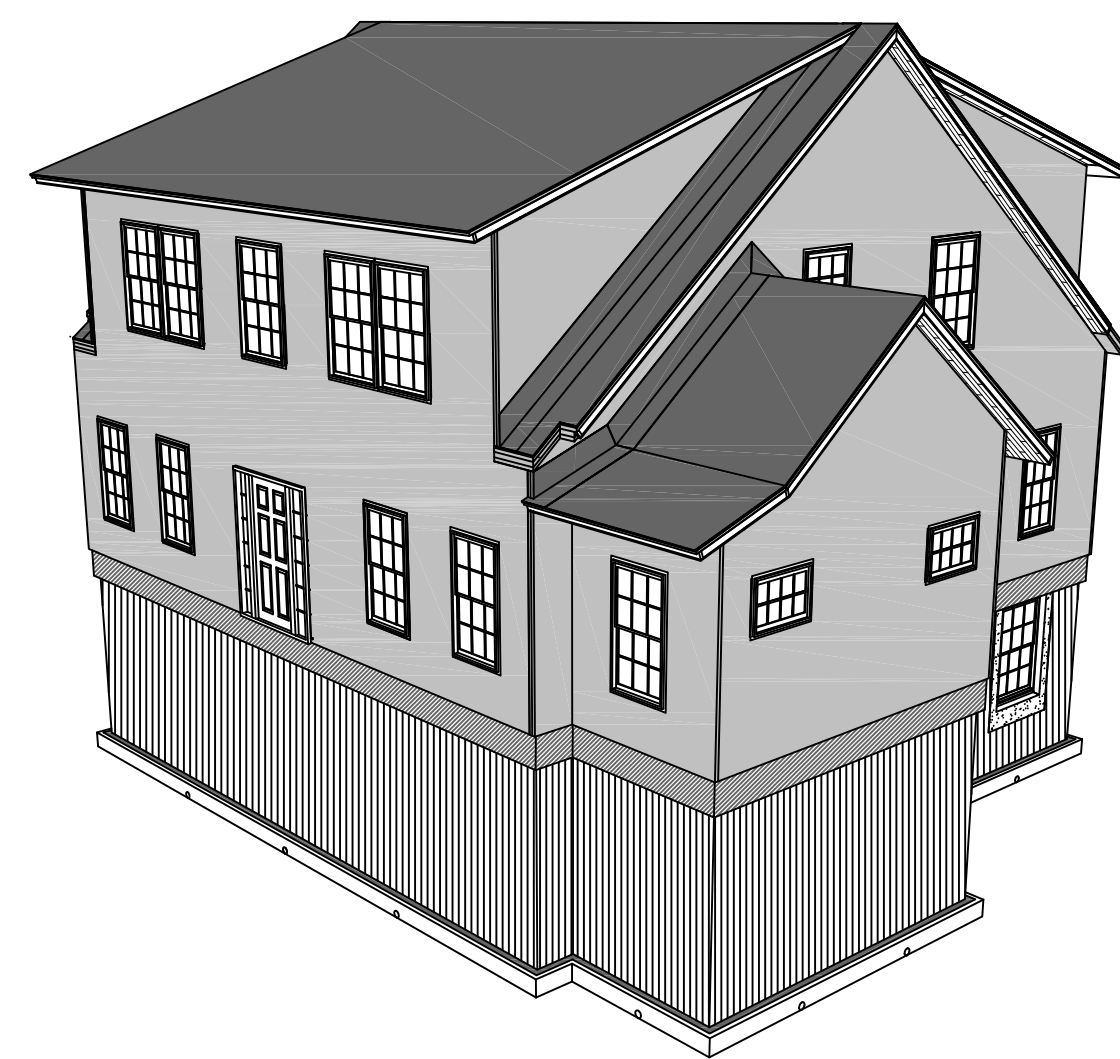
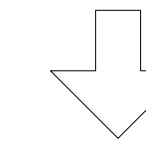

**STEP 14**

1. INSTALL ALL WINDOWS AND DOORS. SEE A-503 AND A-504 FOR WINDOW AND DOOR OPENING WATERPROOFING DETAILS AND INSTALLATION SEQUENCES.

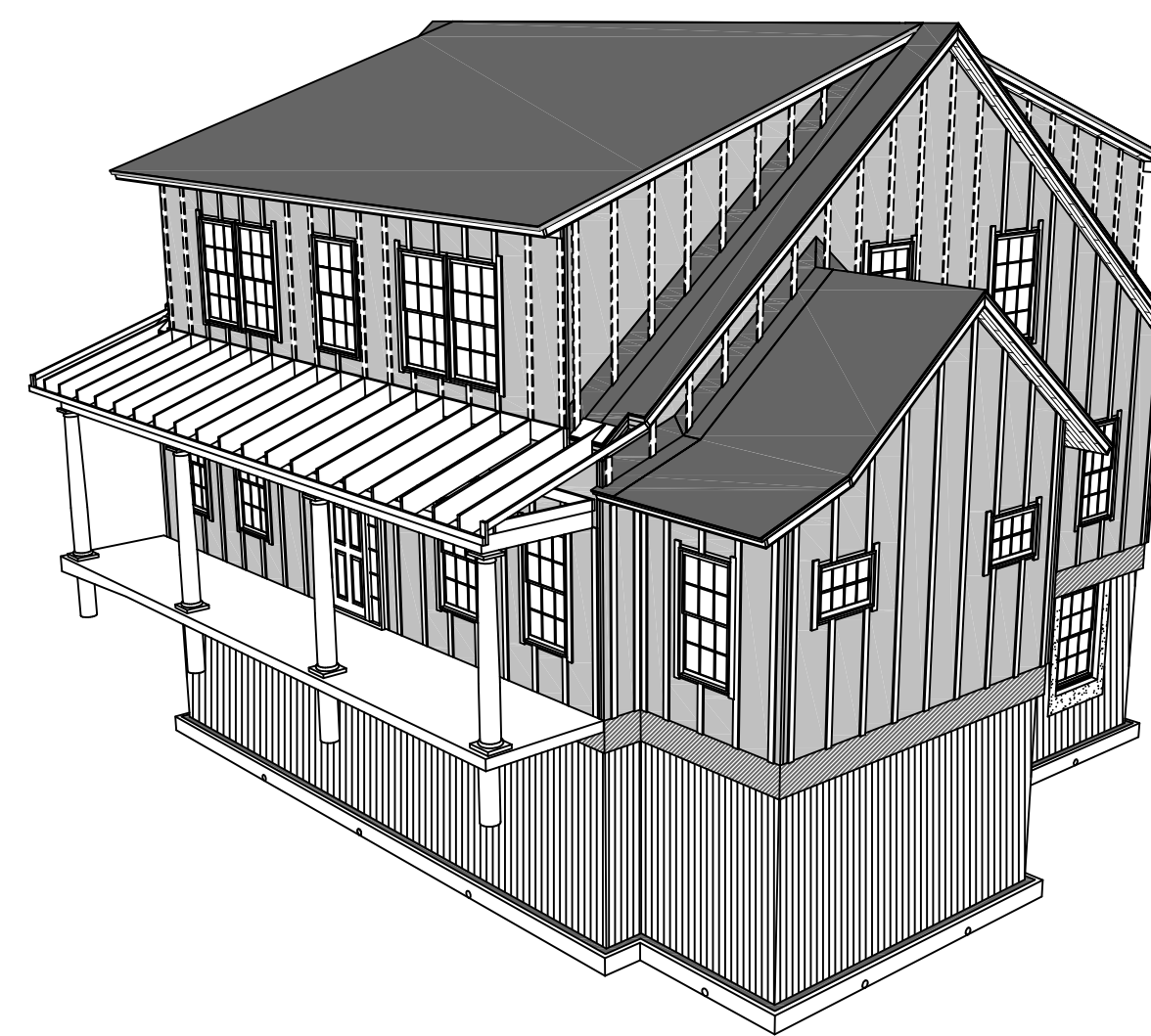
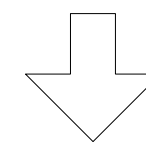

**STEP 17**

1. REMOVE TEMPORARY INSULATING SHEATHING FASTENERS AND INSTALL 1X4 WOOD FURRING STRIPS. SEE A-503 AND A-504 FOR FURRING STRIP INSTALLATION AROUND WINDOWS AND DOORS.
- NOTE: DO NOT INSTALL FURRING STRIPS AT ROOF-TO-WALL INTERSECTIONS (SHOWN AS DASHED LINES) UNTIL FLASHING, TAPE AND SHINGLES HAVE BEEN INSTALLED AT ROOF-TO-WALL LOCATIONS. SEE 4/A-508 AND 4/A-509 FOR DETAILS.

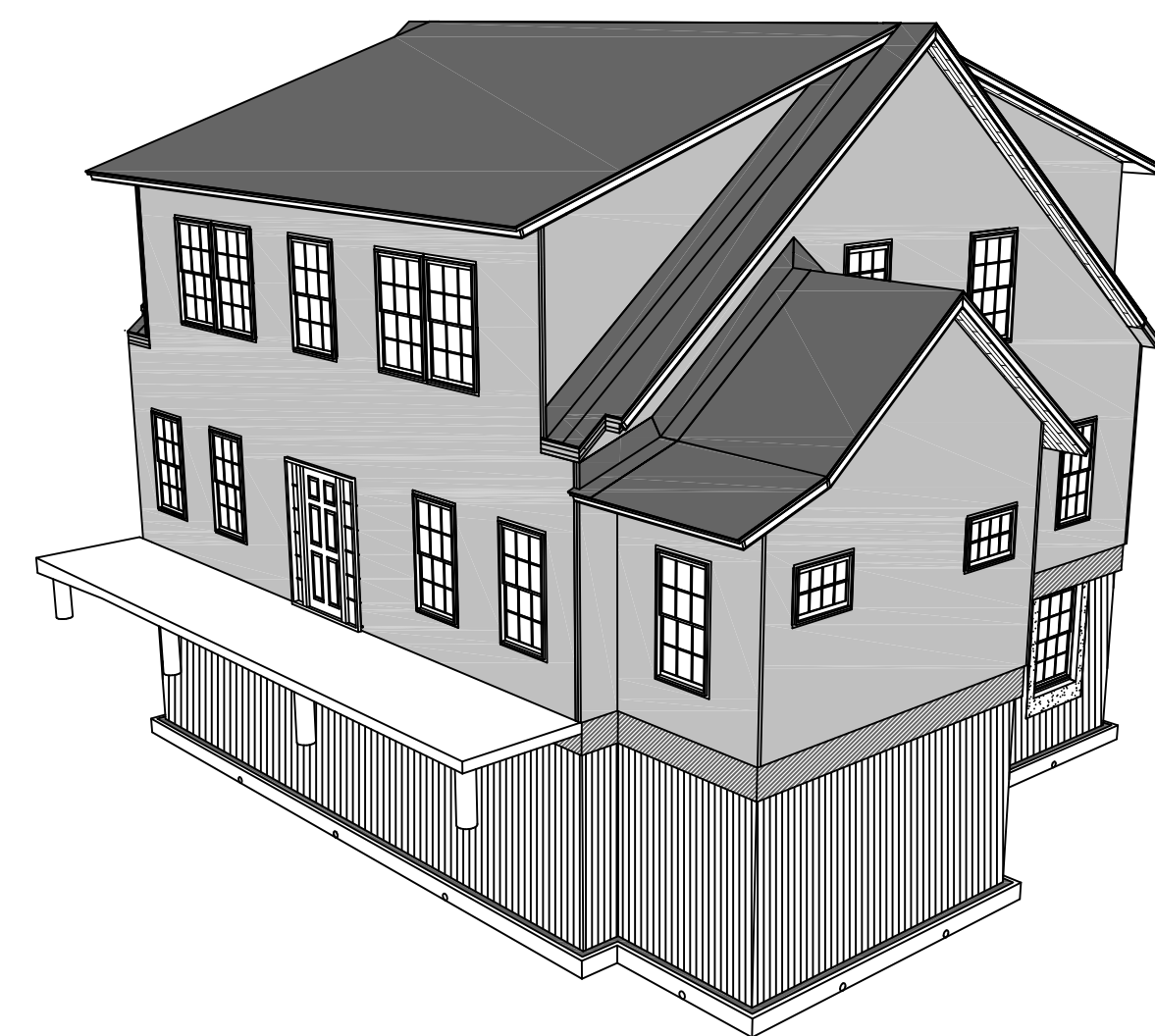
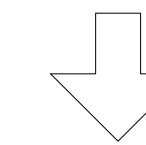

**STEP 15**

1. INSTALL FOUNDATION SYSTEMS FOR FRONT PORCH AND SCREEN PORCH. (SCREEN PORCH NOT SHOWN IN GRAPHIC)
2. INSTALL CONCRETE SLAB FOR FRONT PORCH AND SCREEN PORCH OVER COMPACTED SUBGRADE AND STONE. (SCREEN PORCH NOT SHOWN IN GRAPHIC)

↑  
PROCEED TO  
STEP 16 ABOVE

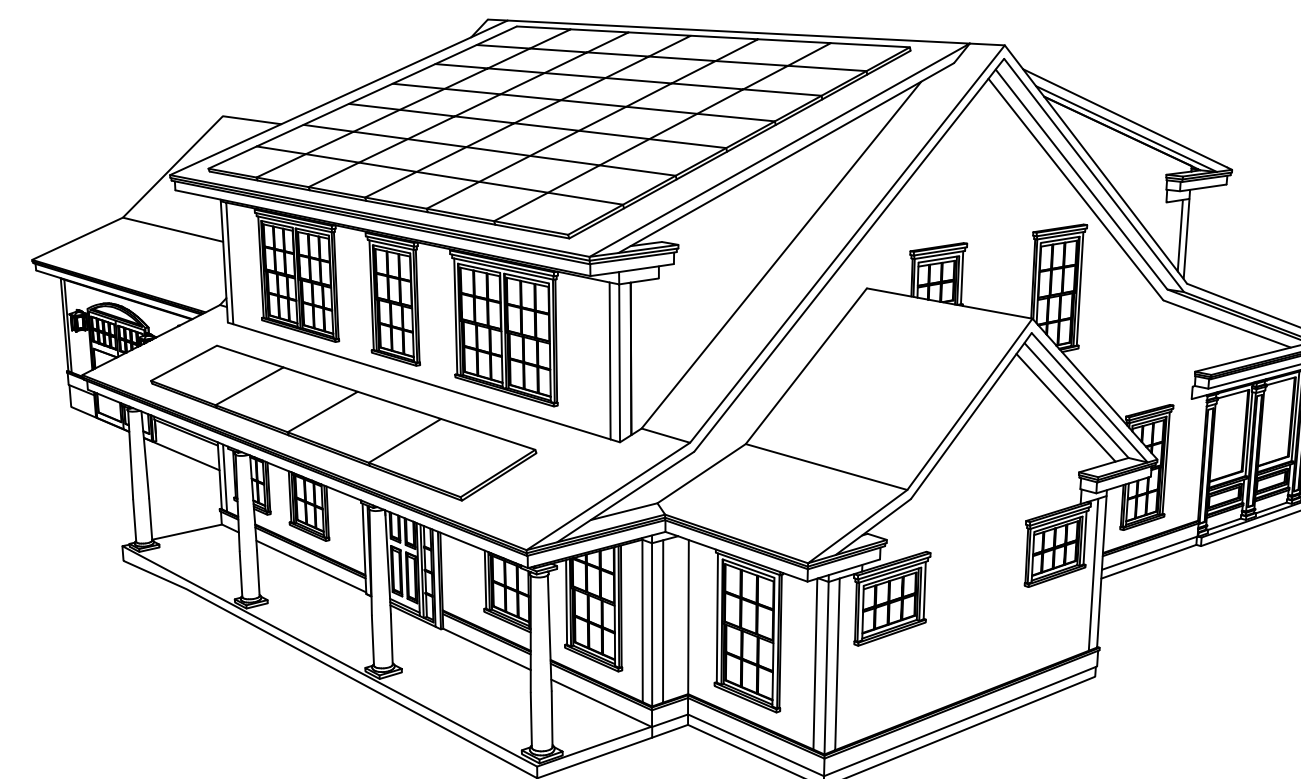

**STEP 18**

1. INSTALL FIBER CEMENT SIDING, TRIM AND ROOFING. SEE A-505 AND A-509 FOR PENETRATION DETAILS.
- NOTE: FINAL IMAGE SHOWN WITH GARAGE STRUCTURE, REAR SCREEN PORCH AND SOLAR THERMAL AND PV PANELS.

**BUILDING SCIENCE CORPORATION**

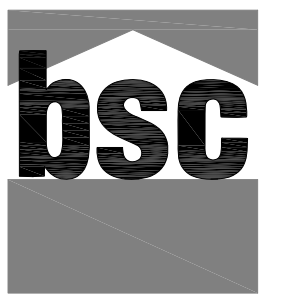

30 FOREST STREET SOMERVILLE, MA  
T: (978) 589-5100 F: (978) 589-5103  
www.buildingscience.com

CONSULTANT:

PROJECT:

National Institute of Standards and Technology

**NET ZERO ENERGY RESIDENTIAL TEST FACILITY**

NIST Campus Gaithersburg, MD



U.S. DEPARTMENT OF ENERGY | Energy Efficiency & Renewable Energy

MARK	DATE	DESCRIPTION
ISSUE:	03/31/10	ISSUED FOR CONSTRUCTION

PROJECT NO: NIST NZERTF  
CAD DWG FILE: A-PLOT-DETL-NZERTF  
DRAWN BY: HW  
CHECKED BY: BP

COPYRIGHT © 2009 BUILDING SCIENCE CORPORATION

SHEET TITLE:

**REQUIRED CONSTRUCTION SEQUENCE - PART C**

SCALE AS NOTED



**A-501C**

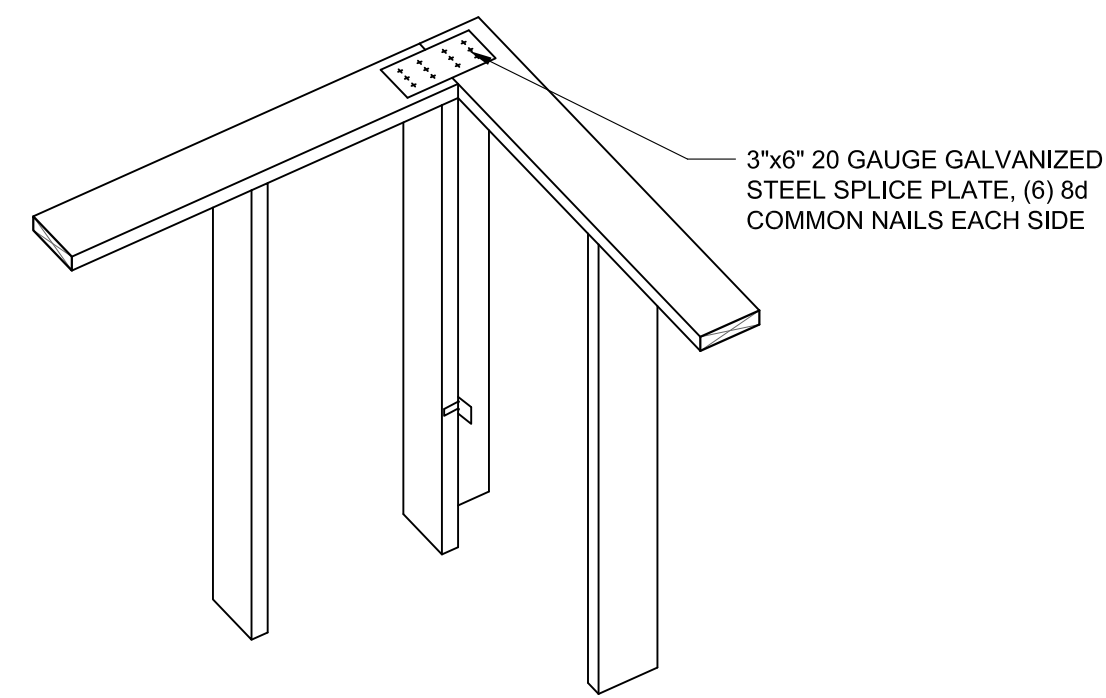

9 TWO-STUD CORNER - TOP  
SCALE: N.T.S.

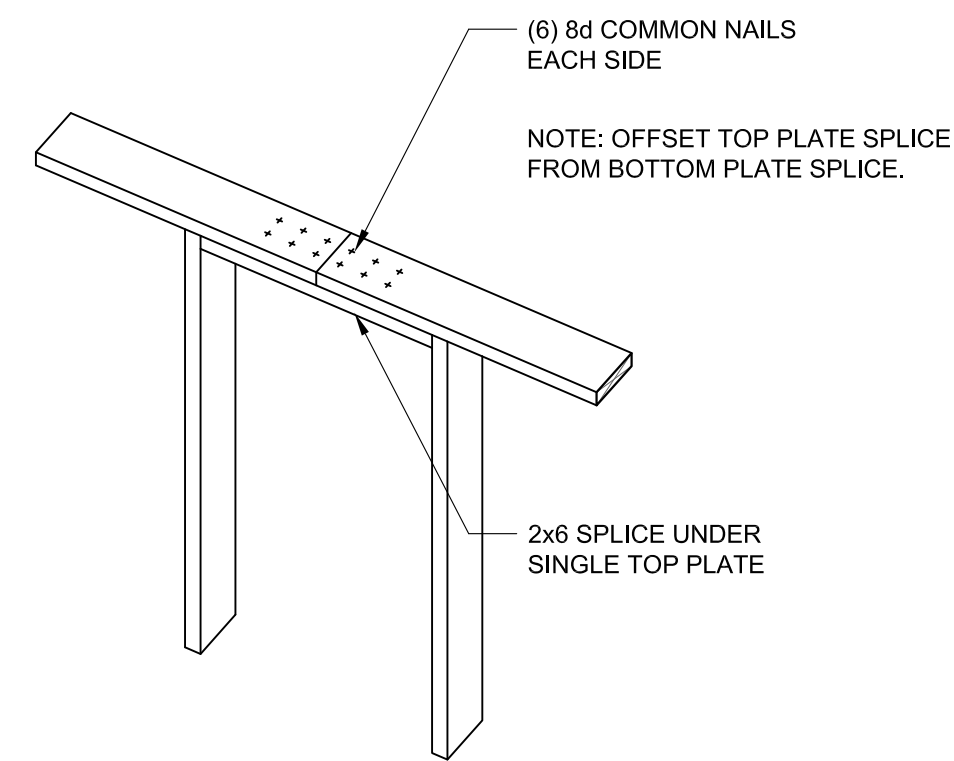

6 SINGLE TOP PLATE SPLICE  
SCALE: N.T.S.

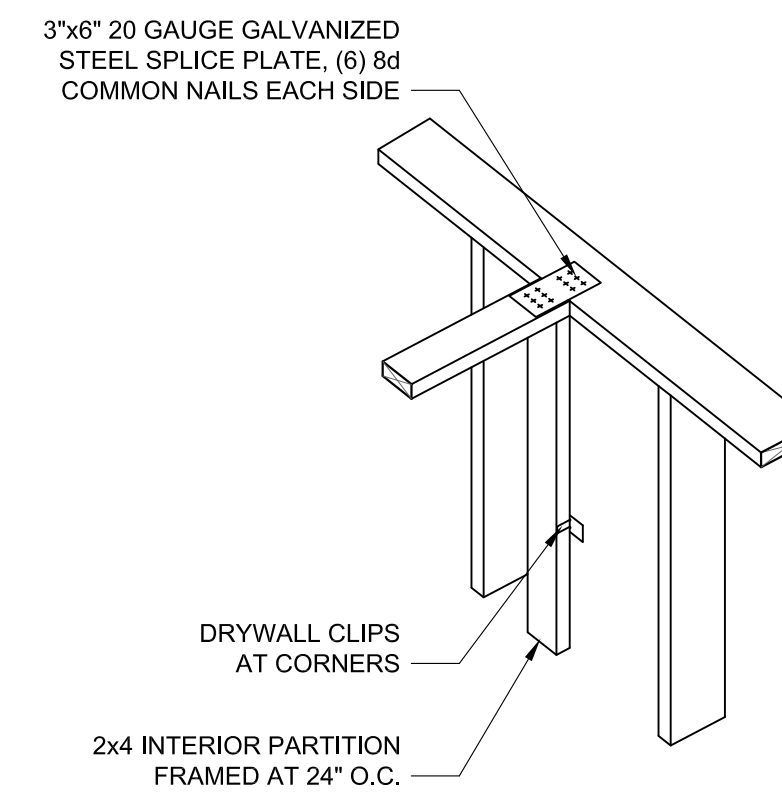

3 SINGLE TOP PLATE AT PARTITION  
SCALE: N.T.S.

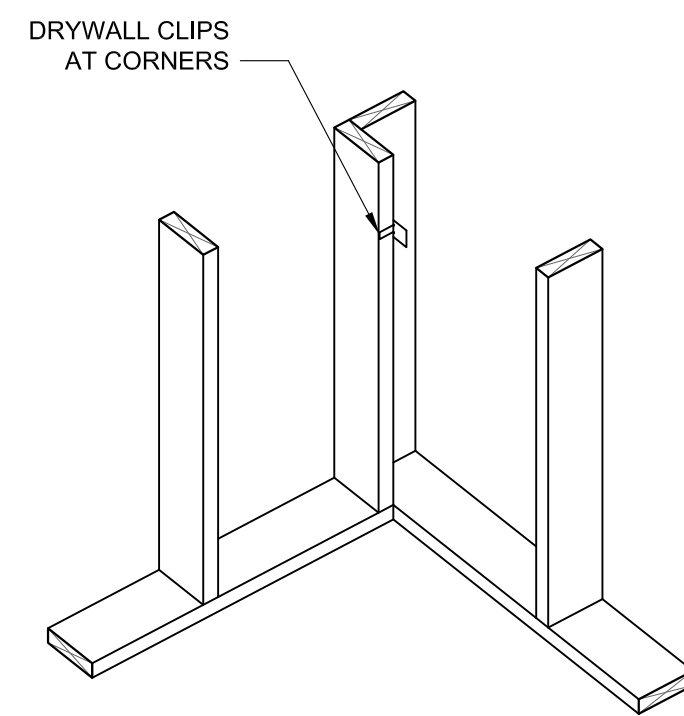

8 TWO-STUD CORNER - BOTTOM  
SCALE: N.T.S.

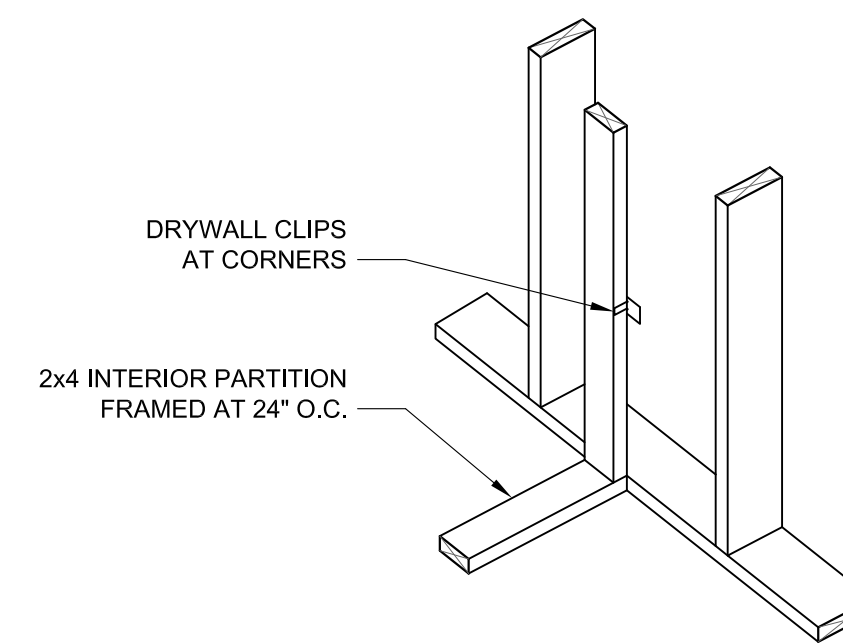

5 BOTTOM PLATE AT PARTITION  
SCALE: N.T.S.

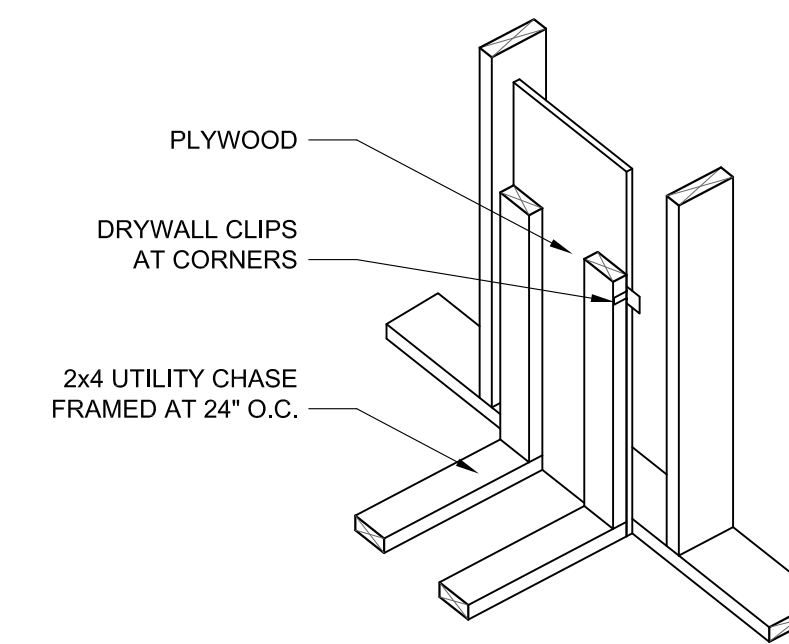

2 CHASE AT EXTERIOR WALL  
SCALE: N.T.S.

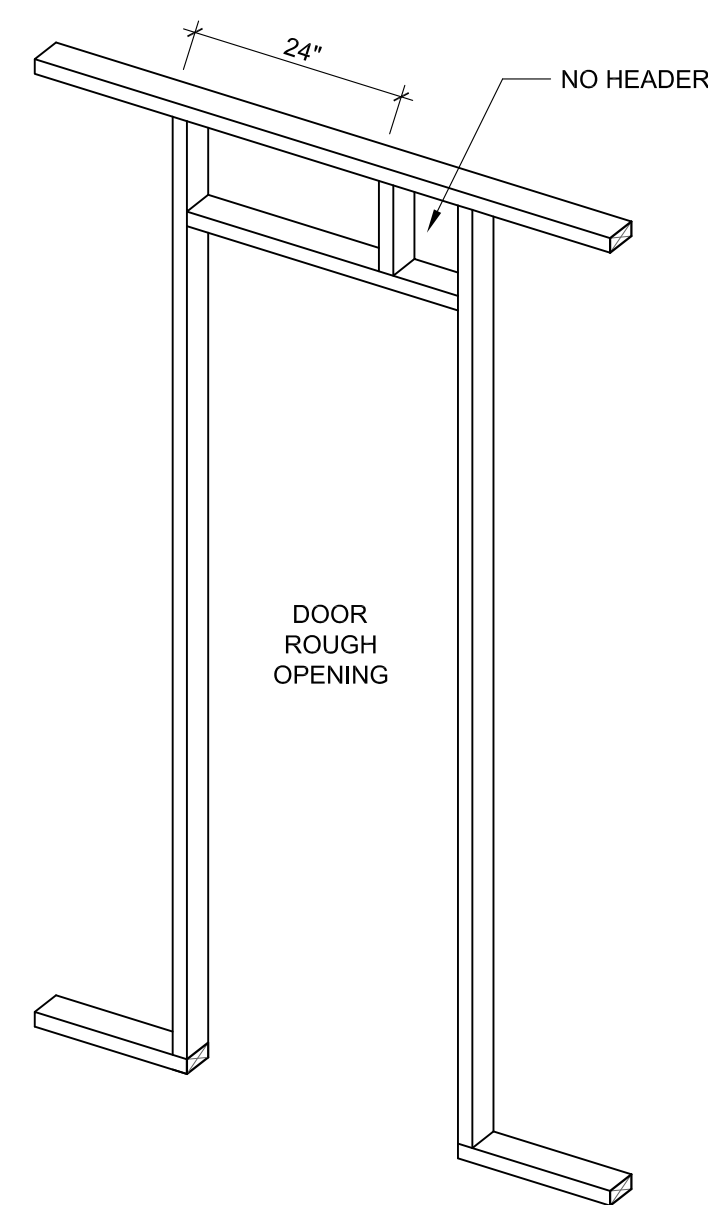

7 NON-LOAD BEARING INTERIOR WALL  
SCALE: N.T.S.

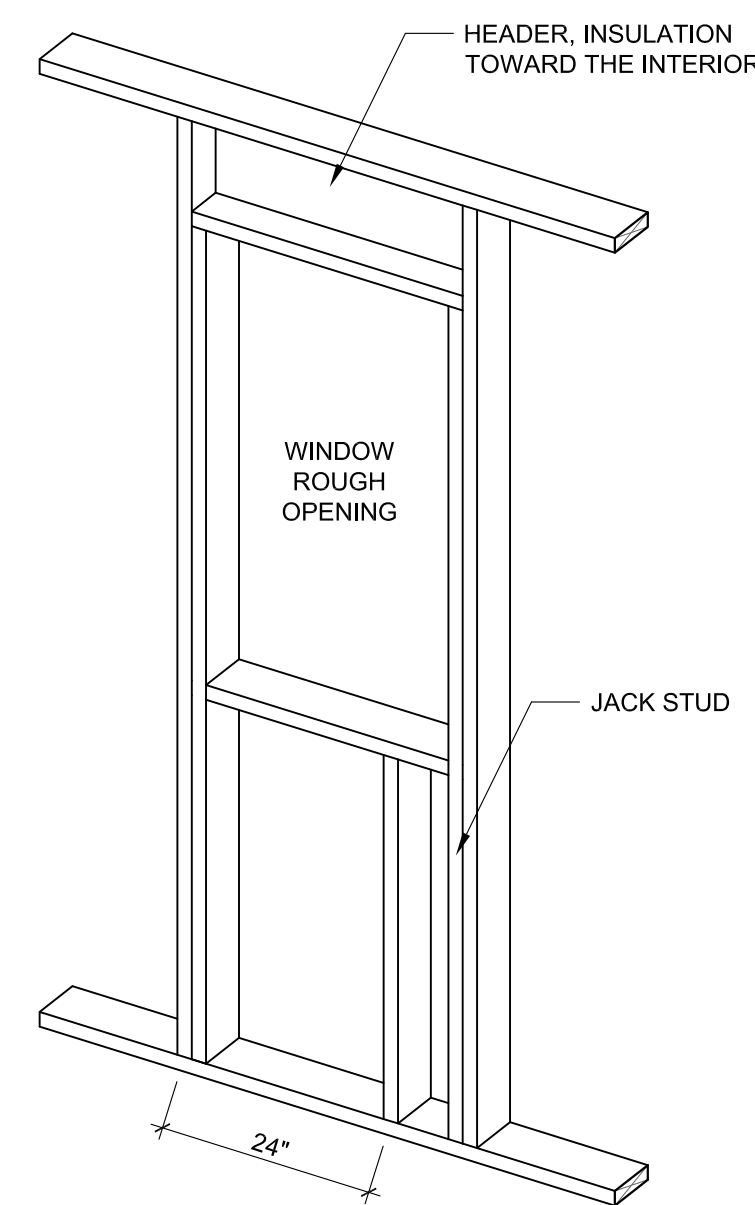

4 LOAD BEARING WALL  
SCALE: N.T.S.

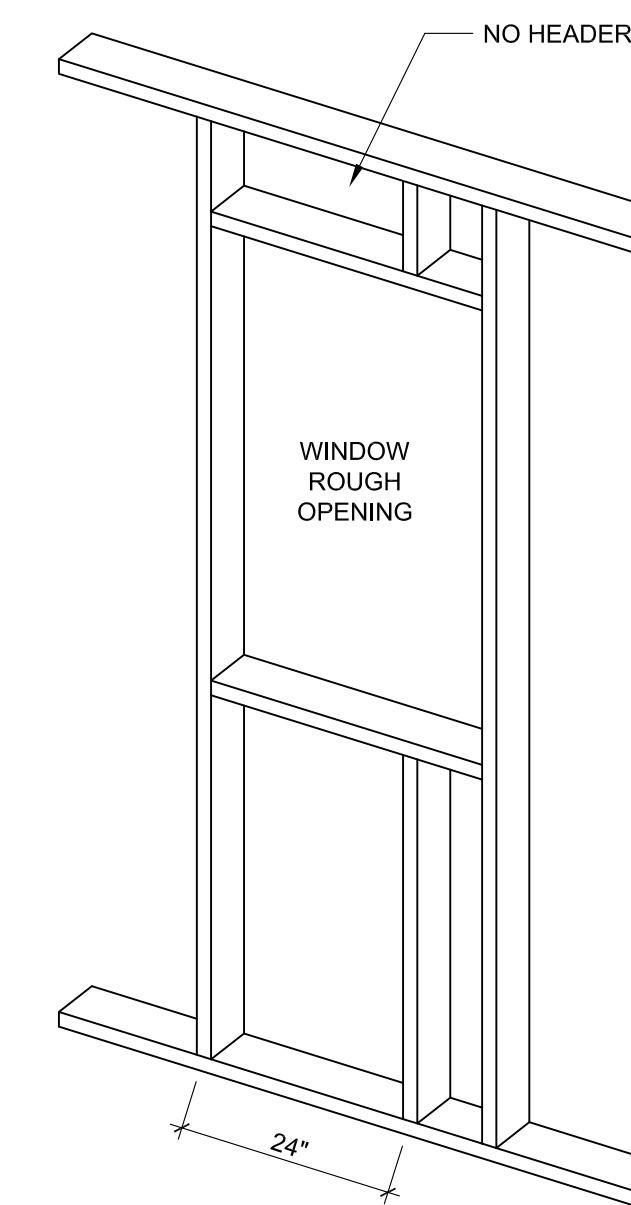

1 NON-LOAD BEARING WALL  
SCALE: N.T.S.

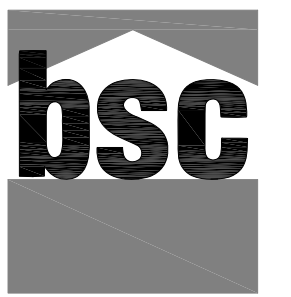

CONSULTANT:

PROJECT:

National Institute of Standards and Technology

NET ZERO ENERGY RESIDENTIAL TEST FACILITY

NIST Campus Gaithersburg, MD



U.S. DEPARTMENT OF ENERGY Energy Efficiency & Renewable Energy

MARK	DATE	DESCRIPTION
ISSUE:	03/31/10	ISSUED FOR CONSTRUCTION

PROJECT NO:	NIST NZERTF
CAD DWG FILE:	A-PLOT-DETL-NZERTF
DRAWN BY:	CG
CHECKED BY:	BP

COPYRIGHT © 2009 BUILDING SCIENCE CORPORATION  
SHEET TITLE:

ADVANCED FRAMING DETAILS

SCALE AS NOTED



A-502





CONSULTANT:

PROJECT:

National Institute of Standards and Technology

**NET ZERO ENERGY RESIDENTIAL TEST FACILITY**

NIST Campus  
Gaithersburg, MD



U.S. DEPARTMENT OF ENERGY | Energy Efficiency & Renewable Energy

MARK	DATE	DESCRIPTION
ISSUE:	03/31/10	ISSUED FOR CONSTRUCTION

PROJECT NO: NIST NZERTF  
CAD DWG FILE: A-PLOT-DET1-NZERTF  
DRAWN BY: CG  
CHECKED BY: BP

COPYRIGHT © 2009  
BUILDING SCIENCE CORPORATION

SHEET TITLE:

**WINDOW DETAILS & INSTALLATION SEQUENCE**

SCALE AS NOTED

**A-503**

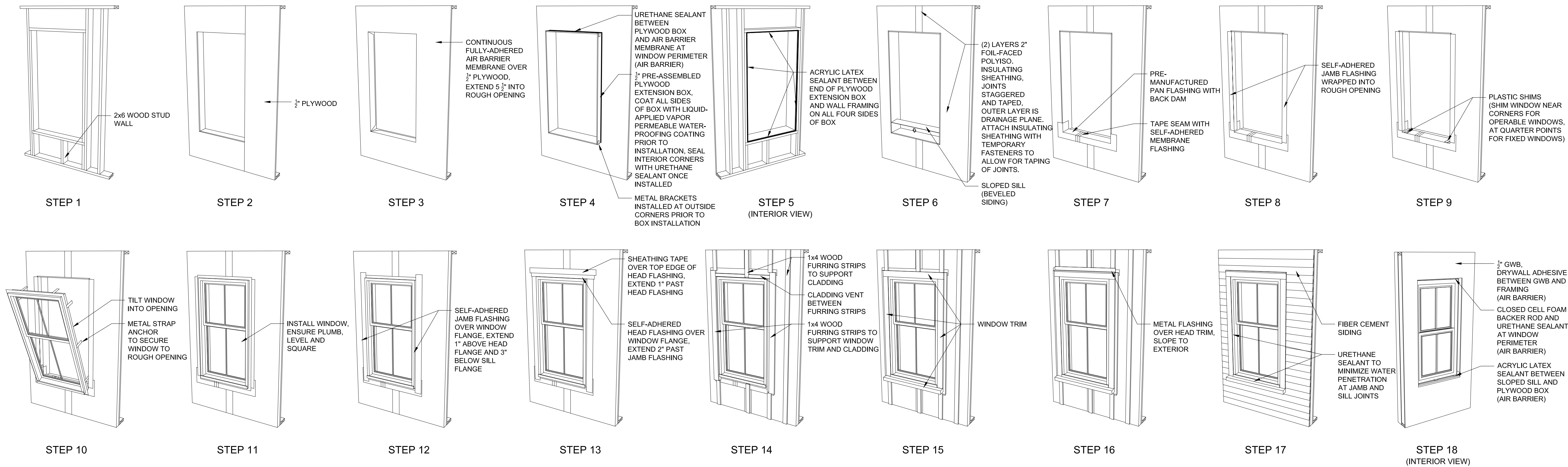

**7 WINDOW INSTALLATION SEQUENCE**

SCALE: N.T.S.

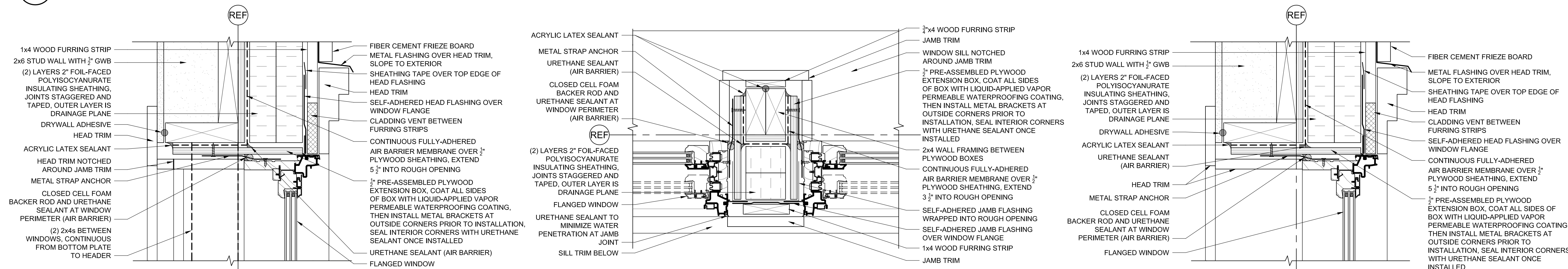

**6 GANGED WINDOW HEAD DETAIL**

SCALE: 3" = 1'-0"

**4 GANGED WINDOW JAMB DETAIL**

SCALE: 3" = 1'-0"

**2 WINDOW HEAD DETAIL**

SCALE: 3" = 1'-0"

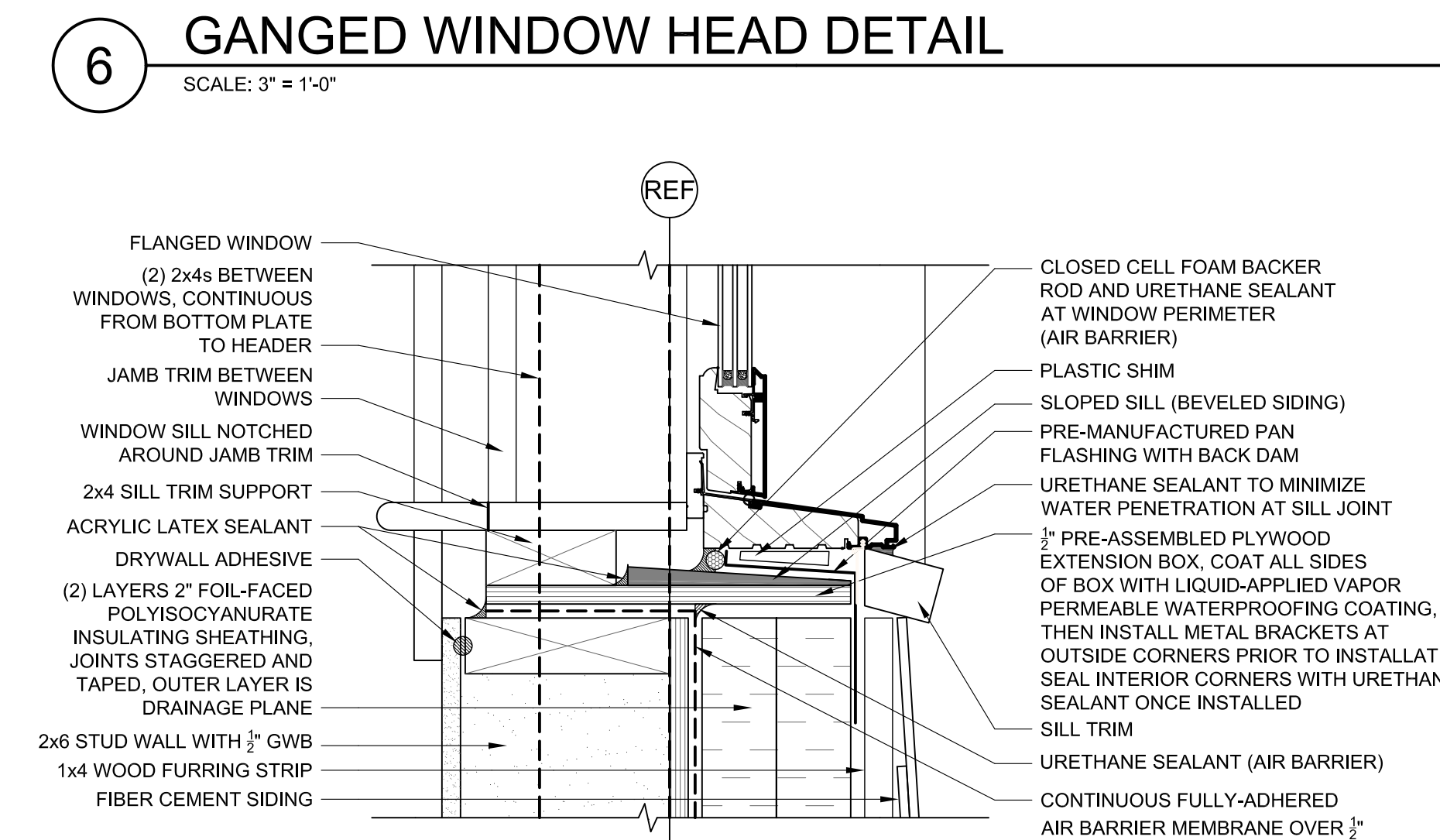

**5 GANGED WINDOW SILL DETAIL**

SCALE: 3" = 1'-0"

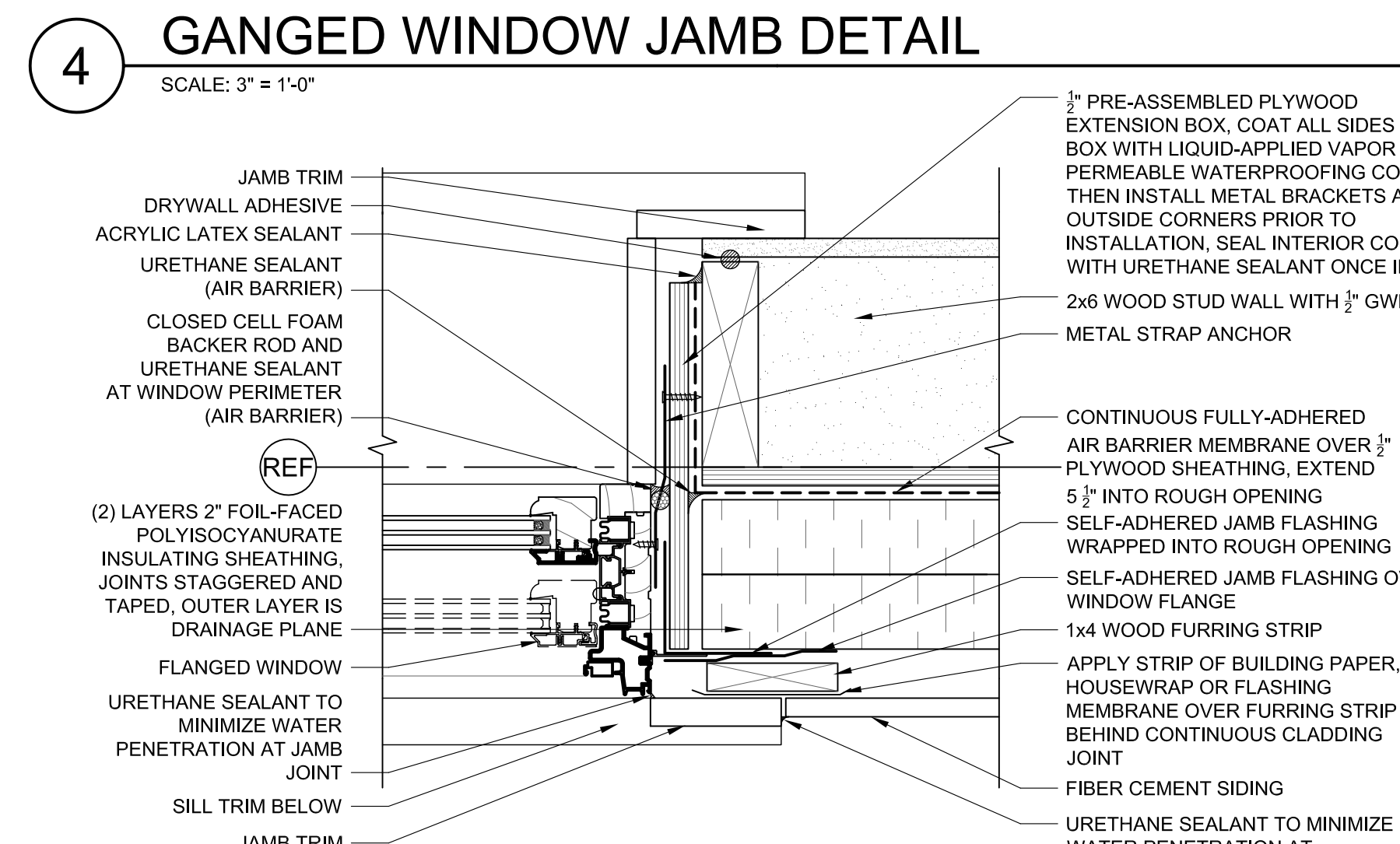

**3 WINDOW JAMB DETAIL**

SCALE: 3" = 1'-0"

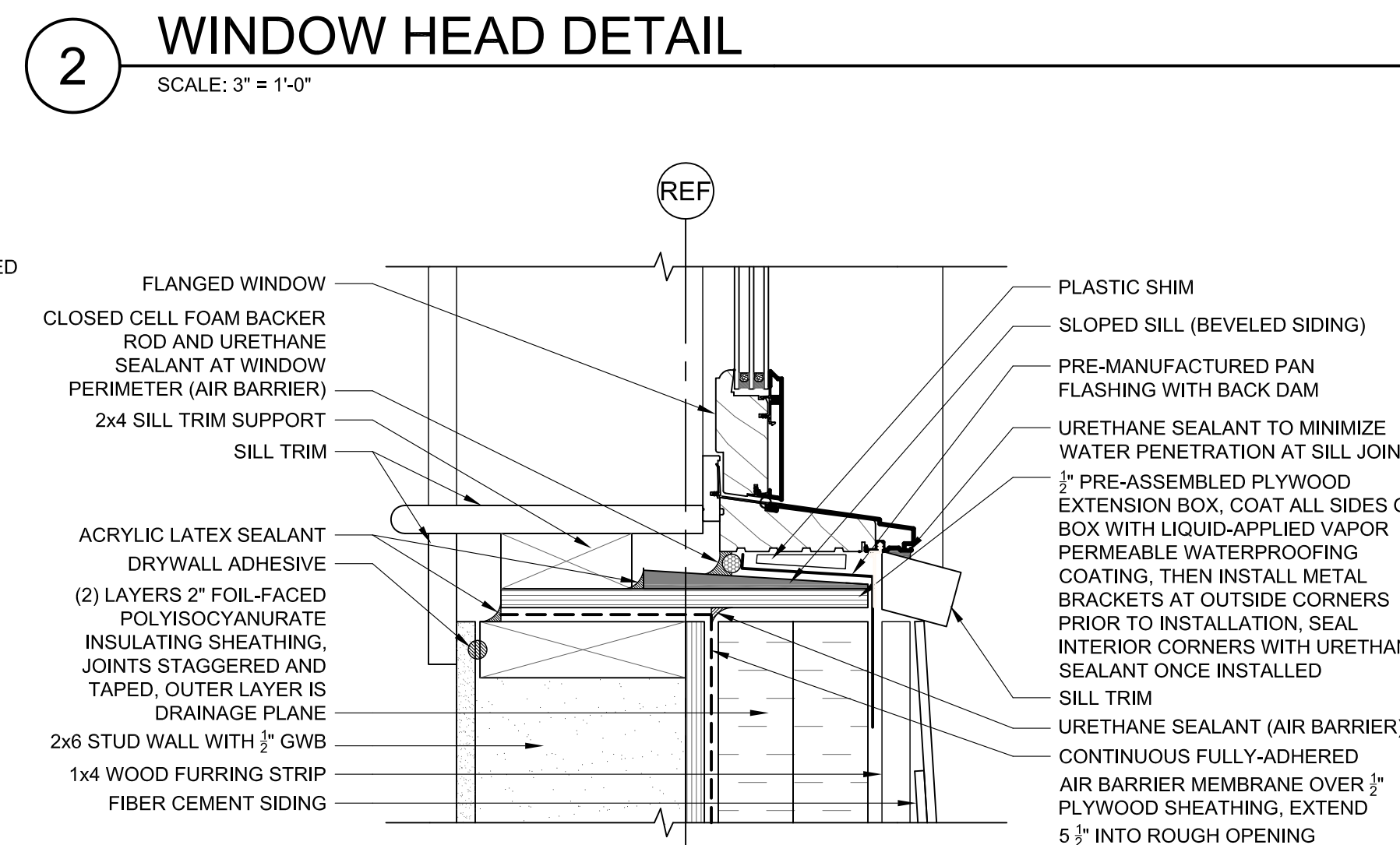

**1 WINDOW SILL DETAIL**

SCALE: 3" = 1'-0"



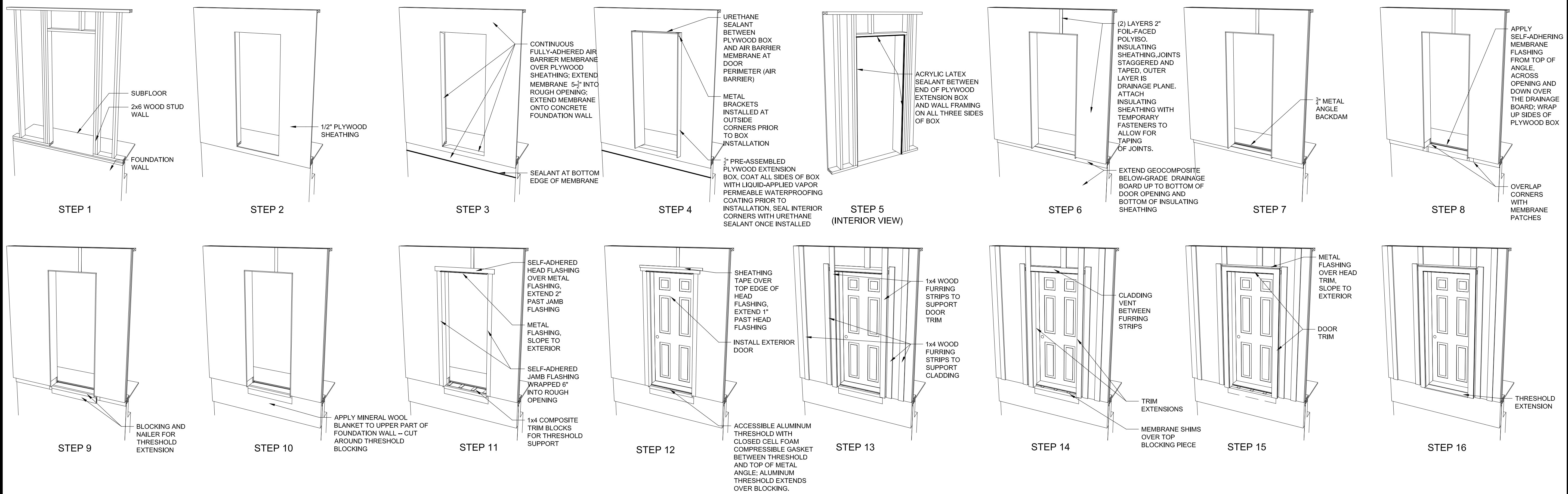

**5 DOOR INSTALLATION SEQUENCE**  
SCALE: N.T.S.

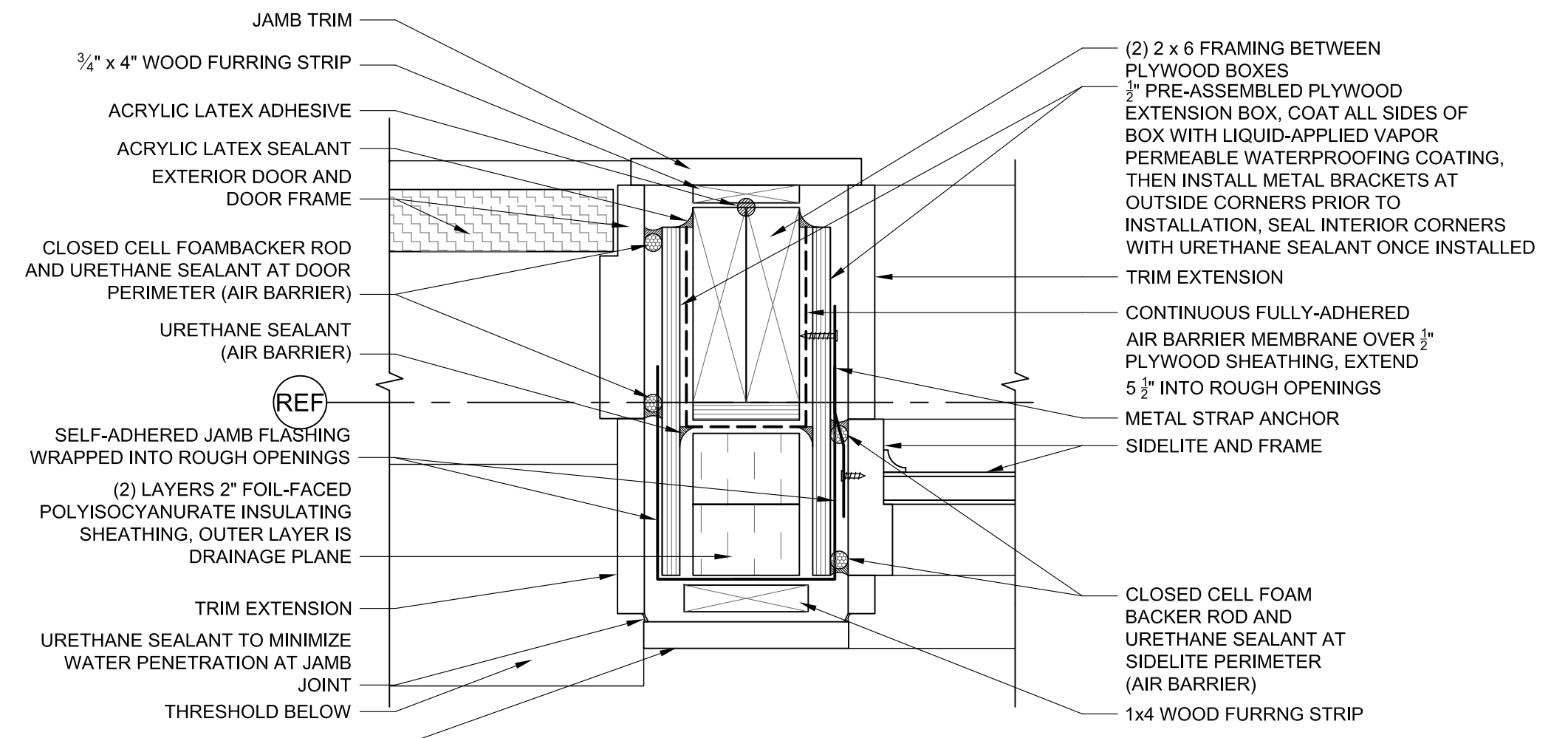

**4 DOOR/SIDELITE JAMB DETAIL**  
SCALE: 3" = 1'-0"

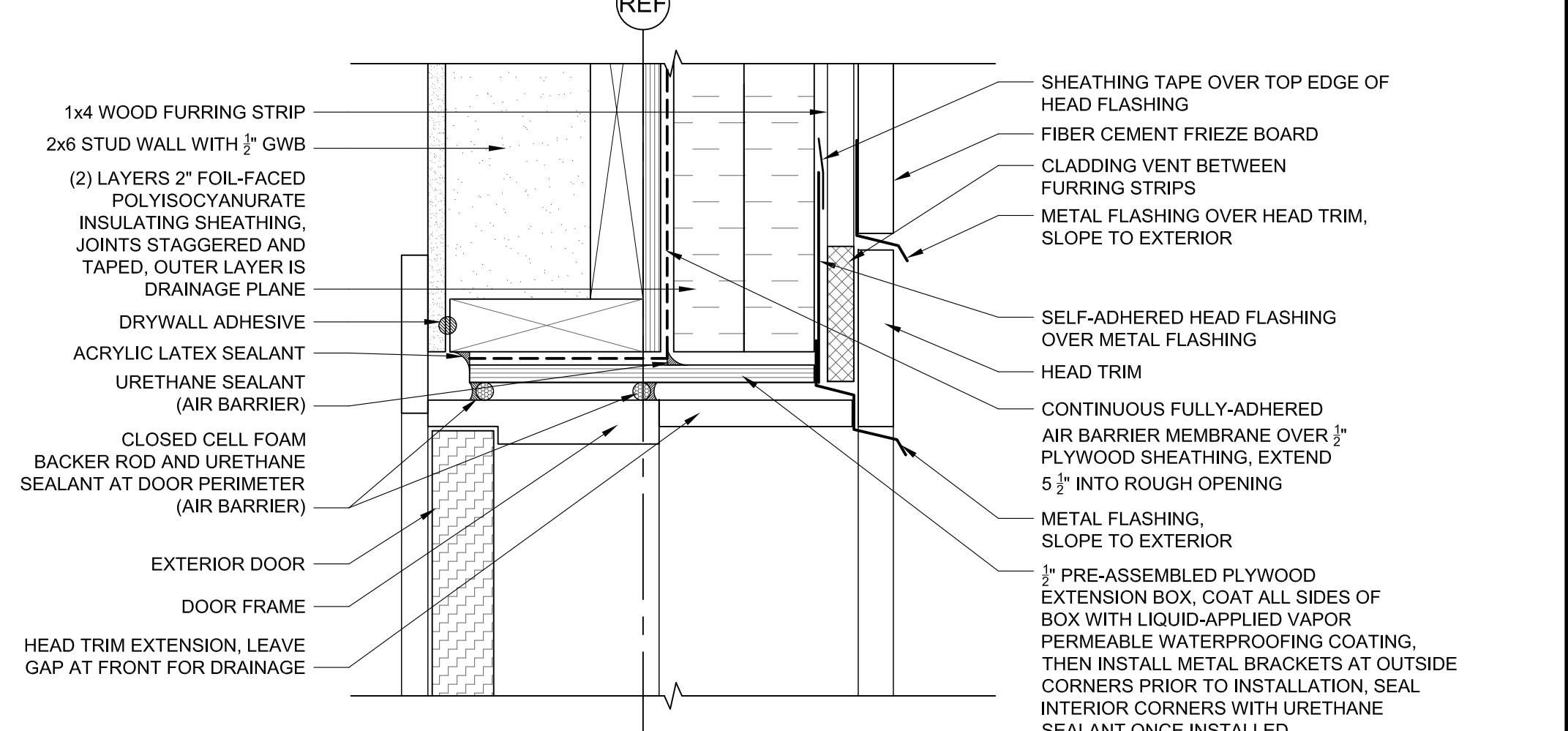

**2 DOOR HEAD DETAIL**  
SCALE: 3" = 1'-0"

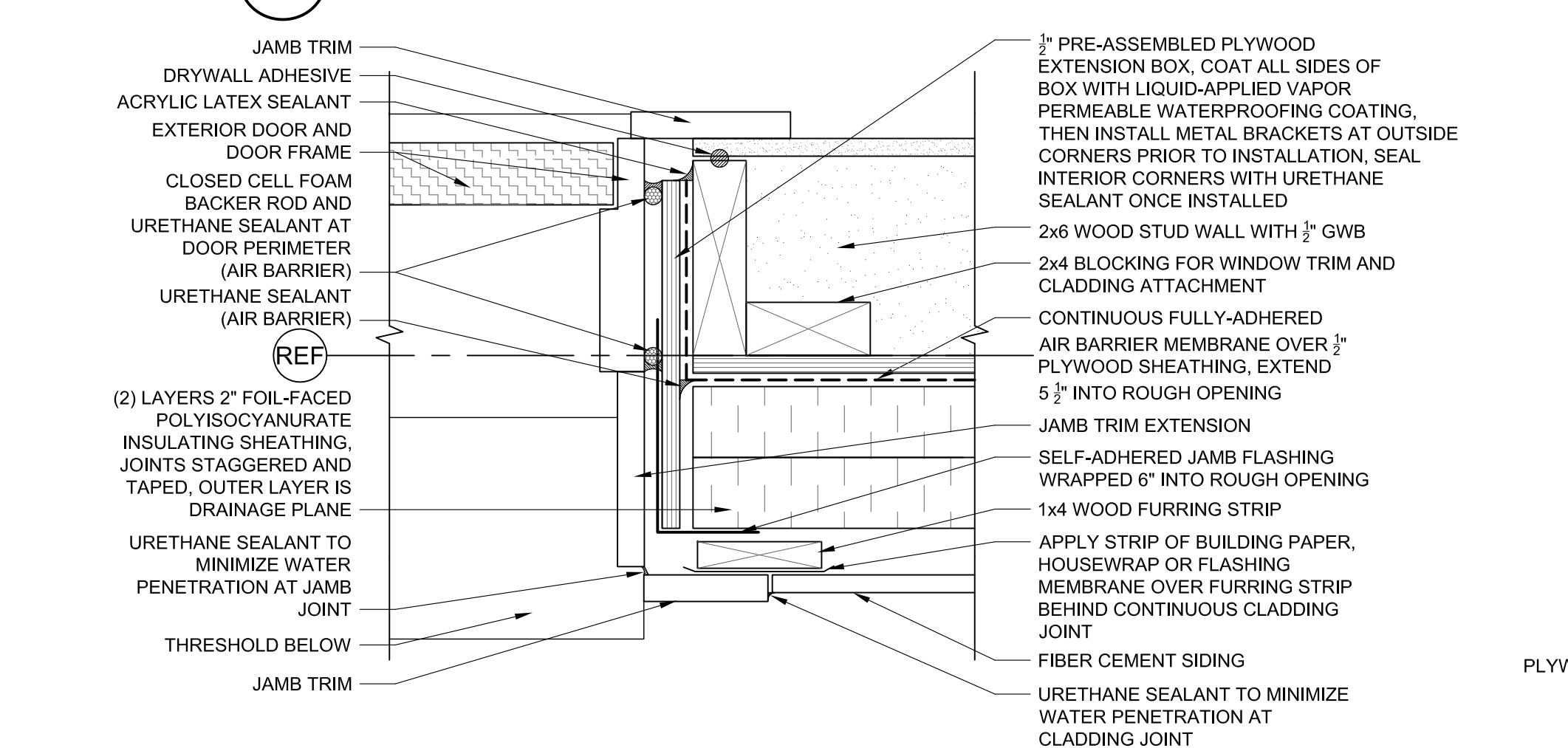

**3 DOOR JAMB DETAIL**  
SCALE: 3" = 1'-0"

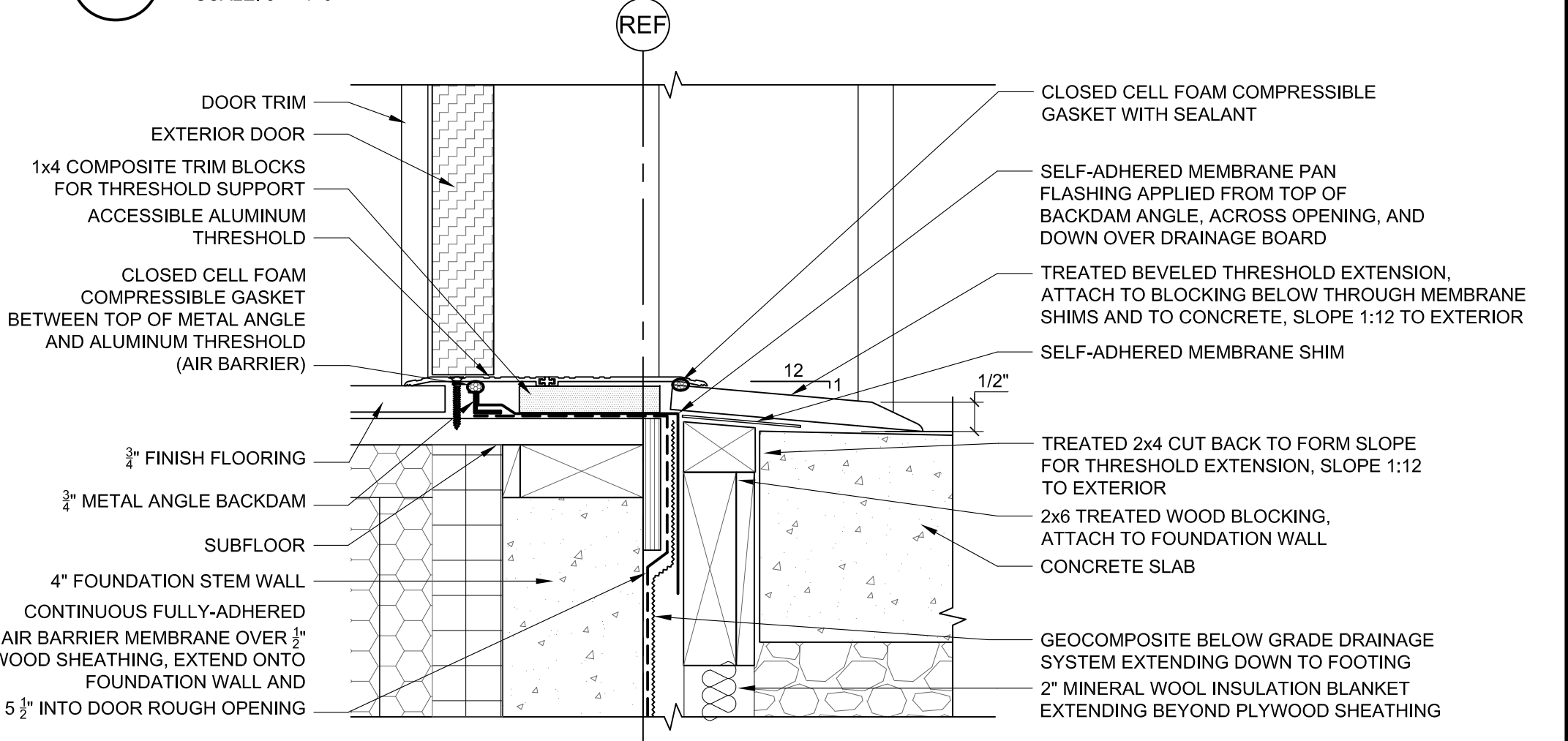

**1 DOOR SILL DETAIL**  
SCALE: 3" = 1'-0"

**BUILDING SCIENCE CORPORATION**  
  
 30 FOREST STREET SOMERVILLE, MA  
 T: (978) 589-5100 F: (978) 589-5103  
 www.buildingscience.com

CONSULTANT:  
 PROJECT:  
 National Institute of Standards and Technology  
**NET ZERO ENERGY RESIDENTIAL TEST FACILITY**  
 NIST Campus Gaithersburg, MD

U.S. Department of Energy  
 Research Toward Zero Energy Homes  
 U.S. DEPARTMENT OF ENERGY | Energy Efficiency & Renewable Energy

MARK	DATE	DESCRIPTION
ISSUE:	03/31/10	ISSUED FOR CONSTRUCTION

PROJECT NO: NIST NZERTF  
 CAD DWG FILE: A-PL0T-DETL-NZERTF  
 DRAWN BY: CG  
 CHECKED BY: BP  
 COPYRIGHT © 2009 BUILDING SCIENCE CORPORATION  
 SHEET TITLE:

**DOOR DETAILS & INSTALLATION SEQUENCE**  
 SCALE AS NOTED

**A-504**





CONSULTANT:

PROJECT:

National Institute of Standards and Technology

**NET ZERO ENERGY RESIDENTIAL TEST FACILITY**

NIST Campus  
Gaithersburg, MD



U.S. DEPARTMENT OF ENERGY | Energy Efficiency & Renewable Energy

MARK	DATE	DESCRIPTION
ISSUE:	03/31/10	ISSUED FOR CONSTRUCTION

PROJECT NO:	NIST NZERTF
CAD DWG FILE:	A-PLOT-DET1-NZERTF
DRAWN BY:	CG
CHECKED BY:	BP

COPYRIGHT © 2009  
BUILDING SCIENCE CORPORATION

**ENCLOSURE PENETRATION DETAILS & SEQUENCES**

SCALE AS NOTED

**A-505**

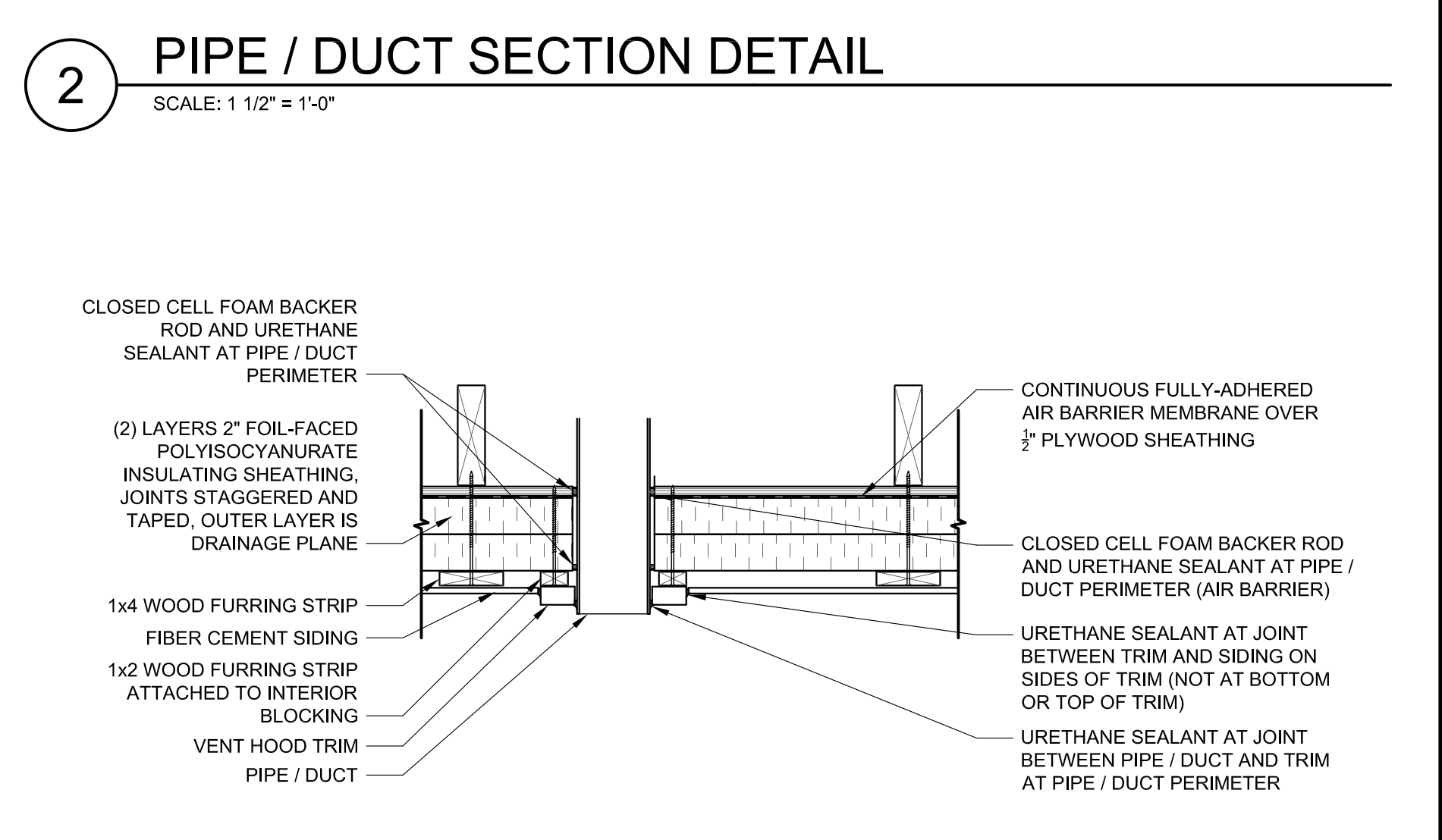
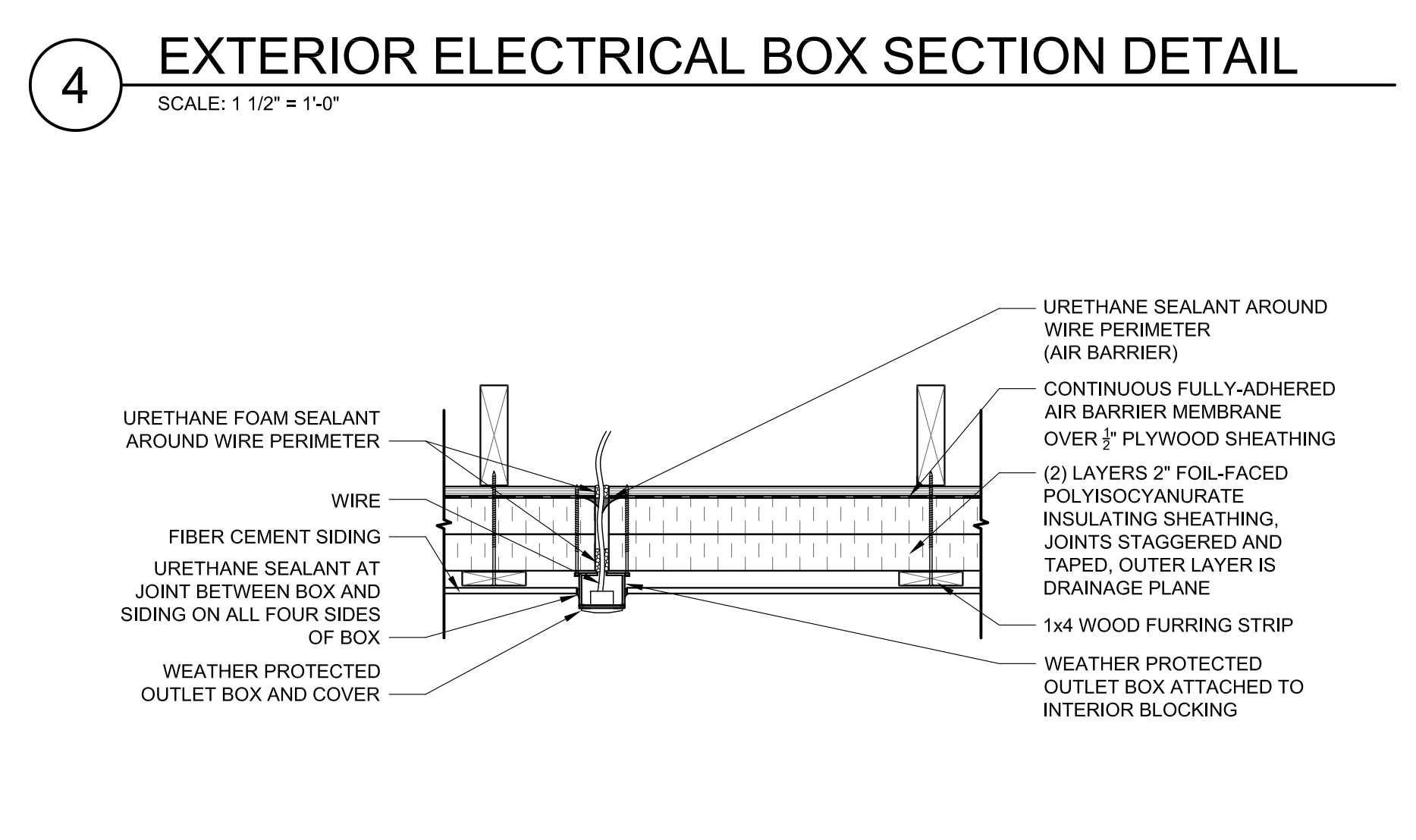
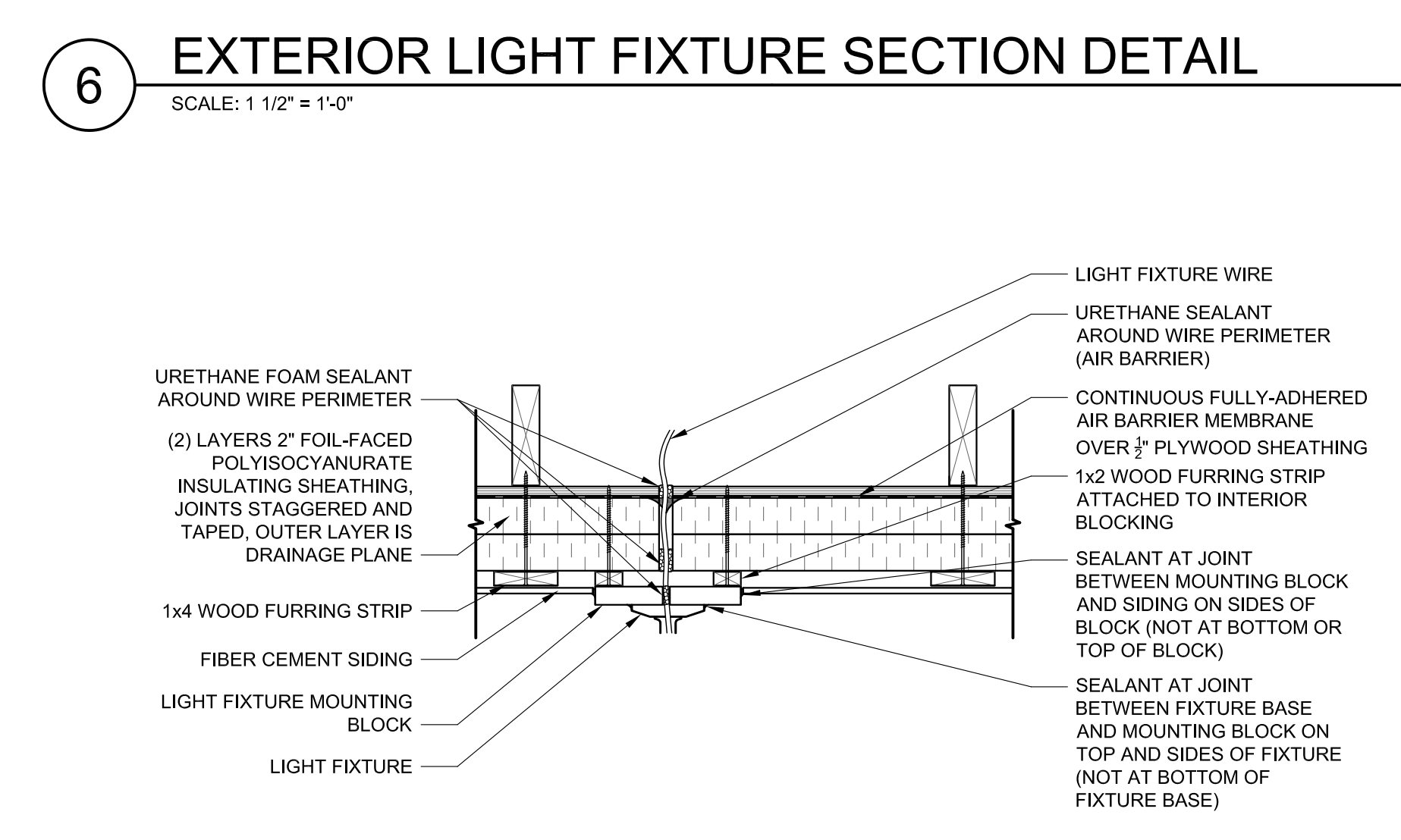
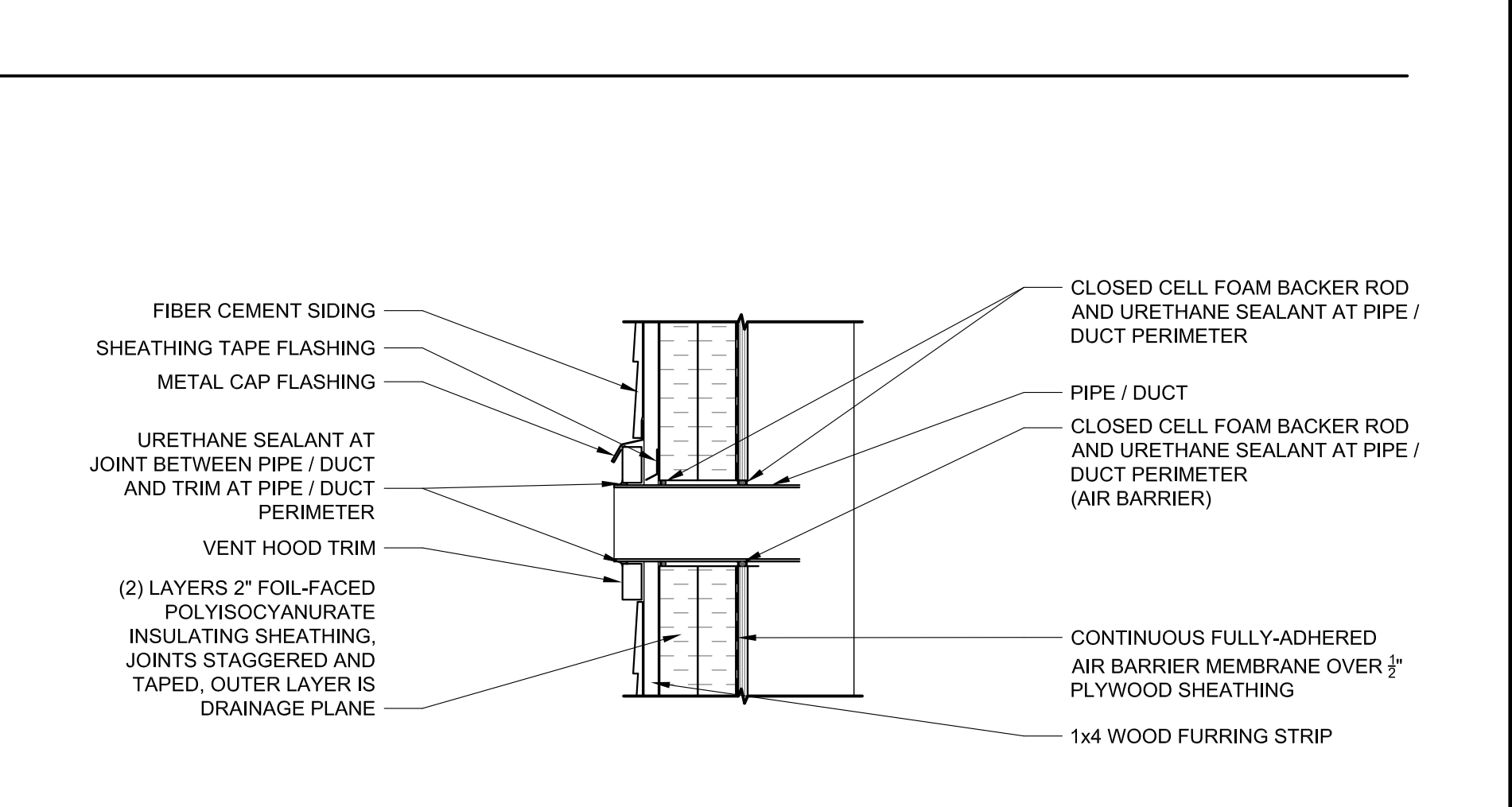
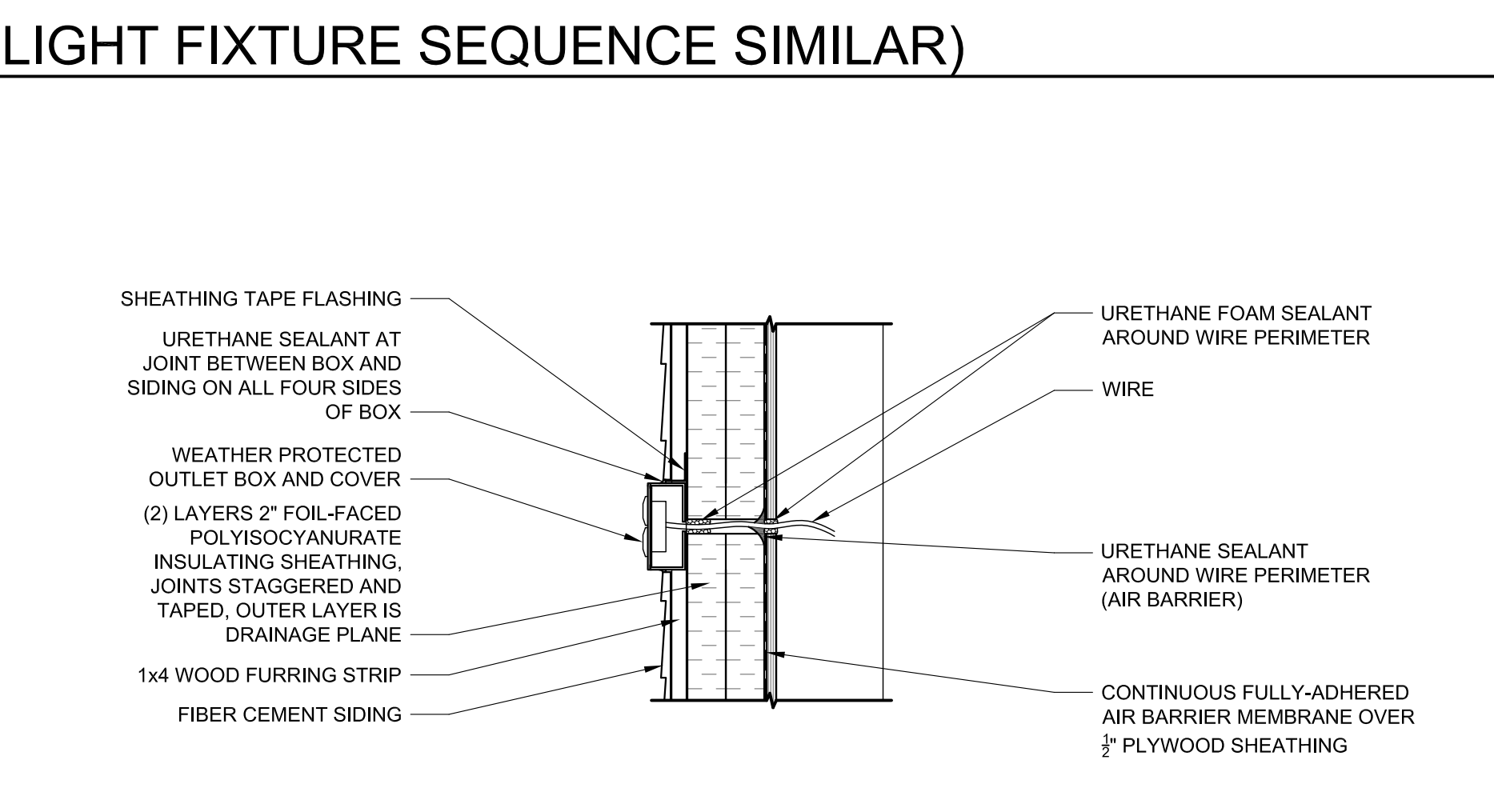
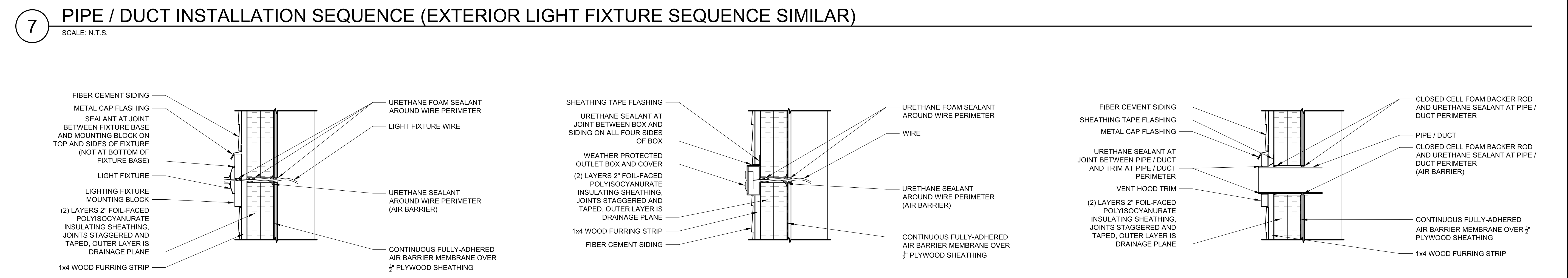
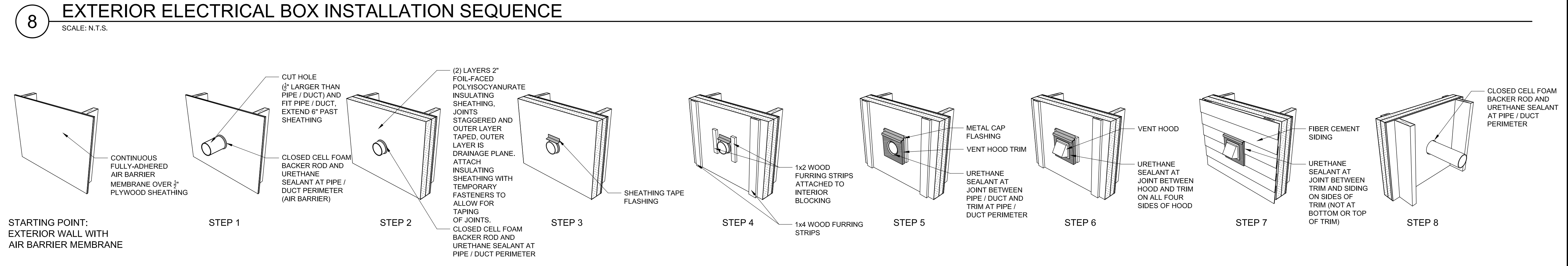
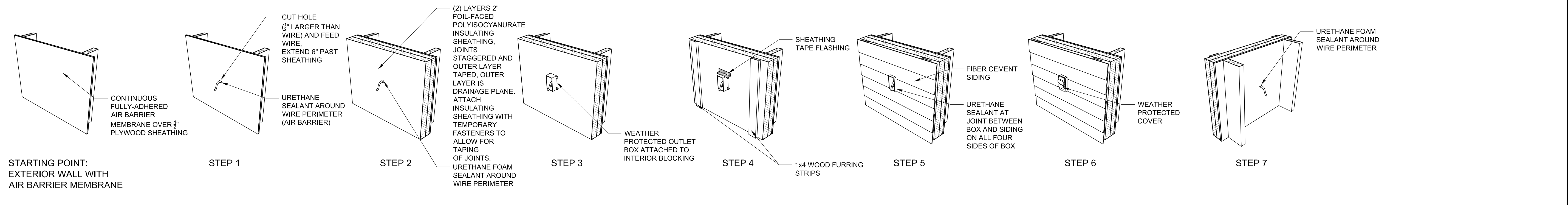





CONSULTANT:

PROJECT:  
National Institute of Standards and Technology

**NET ZERO ENERGY RESIDENTIAL TEST FACILITY**

NIST Campus  
Gaithersburg, MD



U.S. DEPARTMENT OF ENERGY | Energy Efficiency & Renewable Energy

MARK	DATE	DESCRIPTION
ISSUE:	03/31/10	ISSUED FOR CONSTRUCTION

PROJECT NO:	NIST NZERTF
CAD DWG FILE:	A-PL0T-DETL-NZERTF
DRAWN BY:	CG
CHECKED BY:	BP

COPYRIGHT © 2009  
BUILDING SCIENCE CORPORATION

**FOUNDATION DETAILS**

SCALE AS NOTED

**A-506**

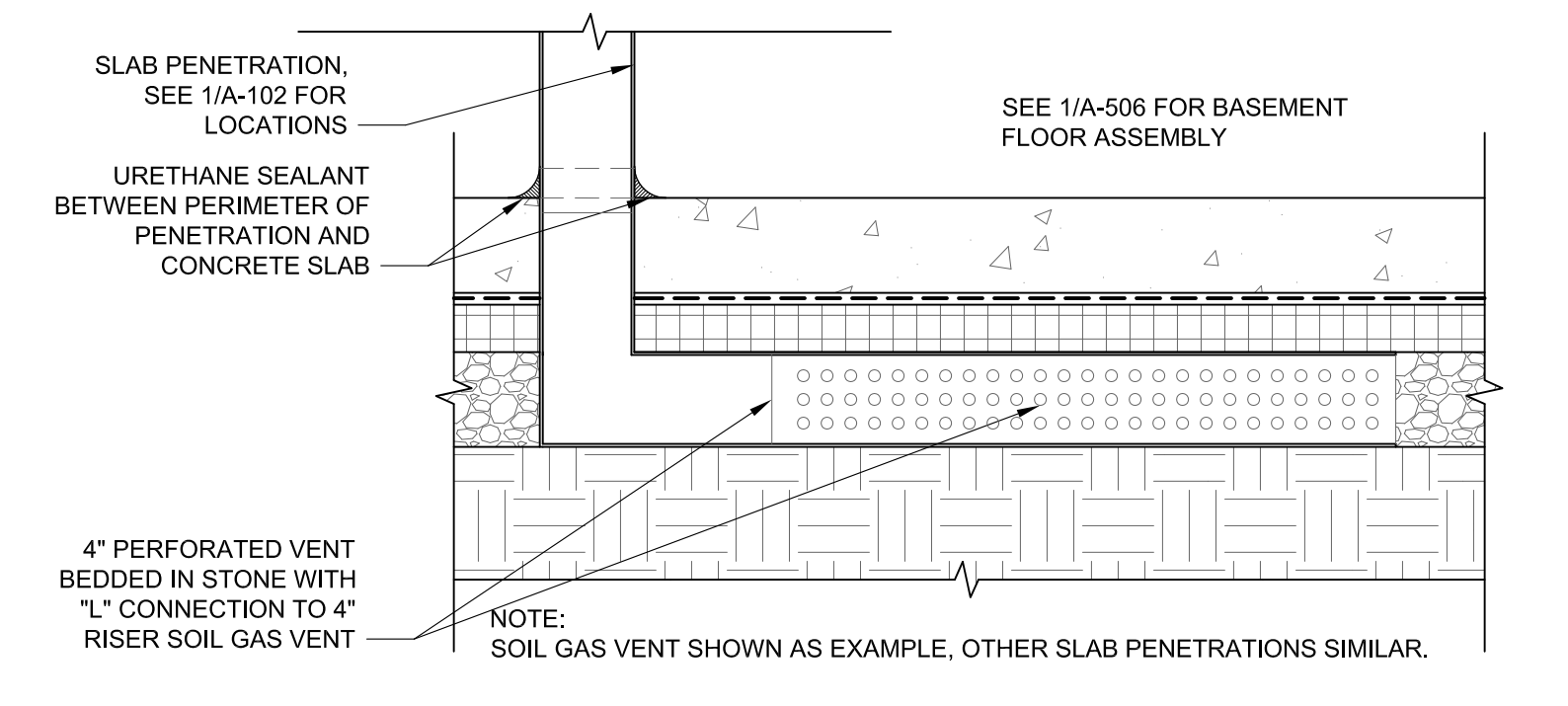

**4 SLAB PENETRATION DETAIL**  
SCALE: 1 1/2" = 1'-0"

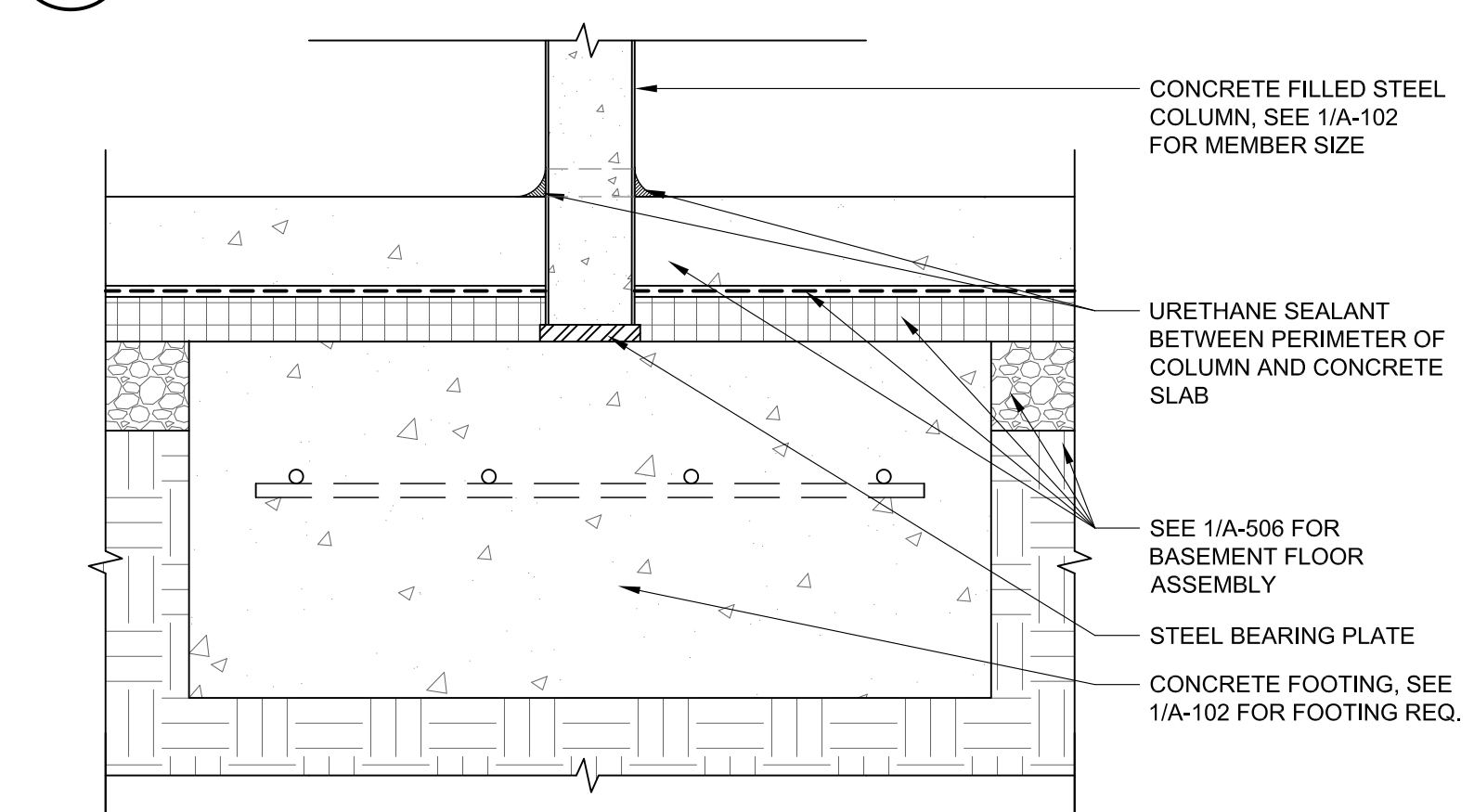

**3 COLUMN & FOOTING DETAIL**  
SCALE: 1 1/2" = 1'-0"

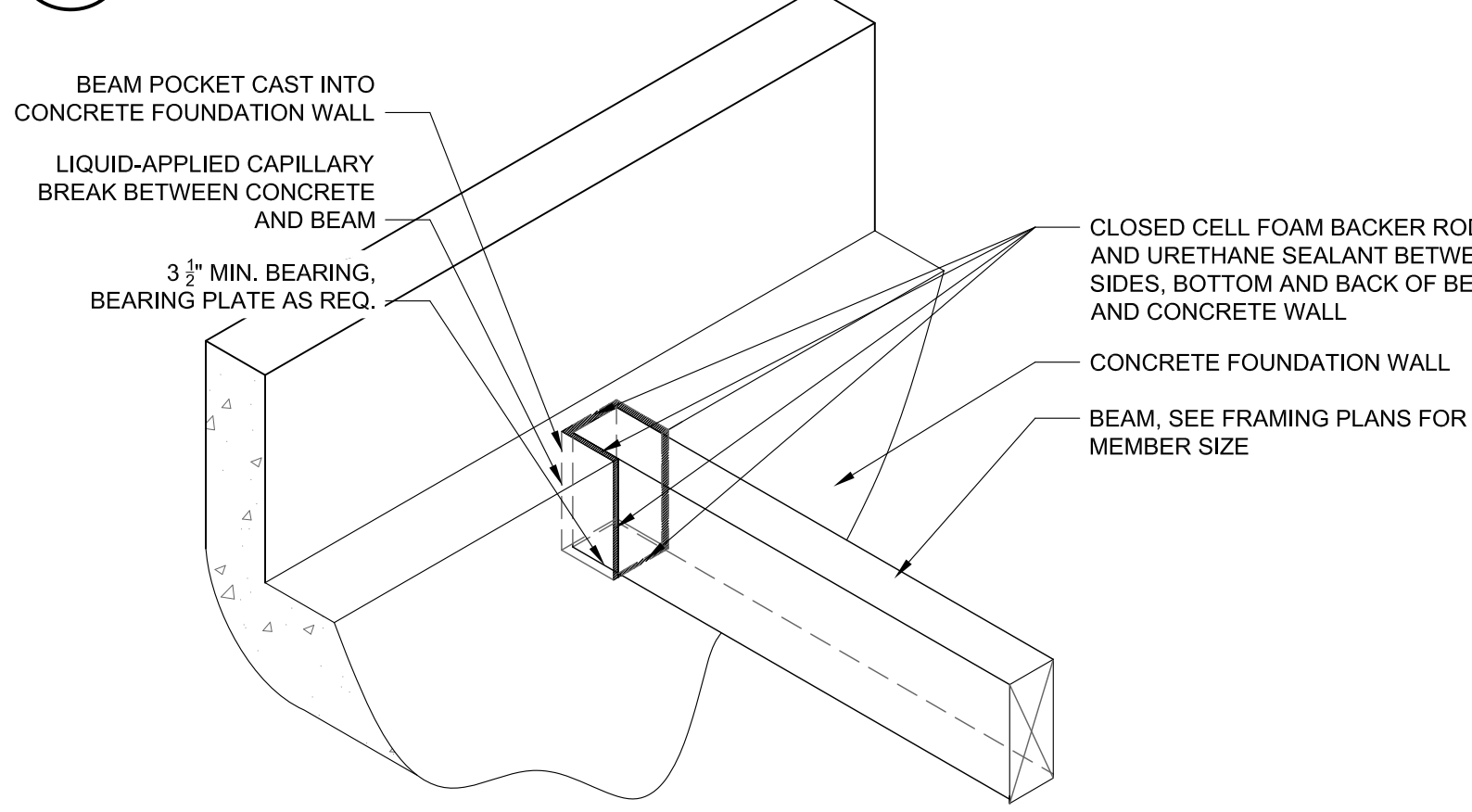

**2 BEAM POCKET DETAIL**  
SCALE: N.T.S.

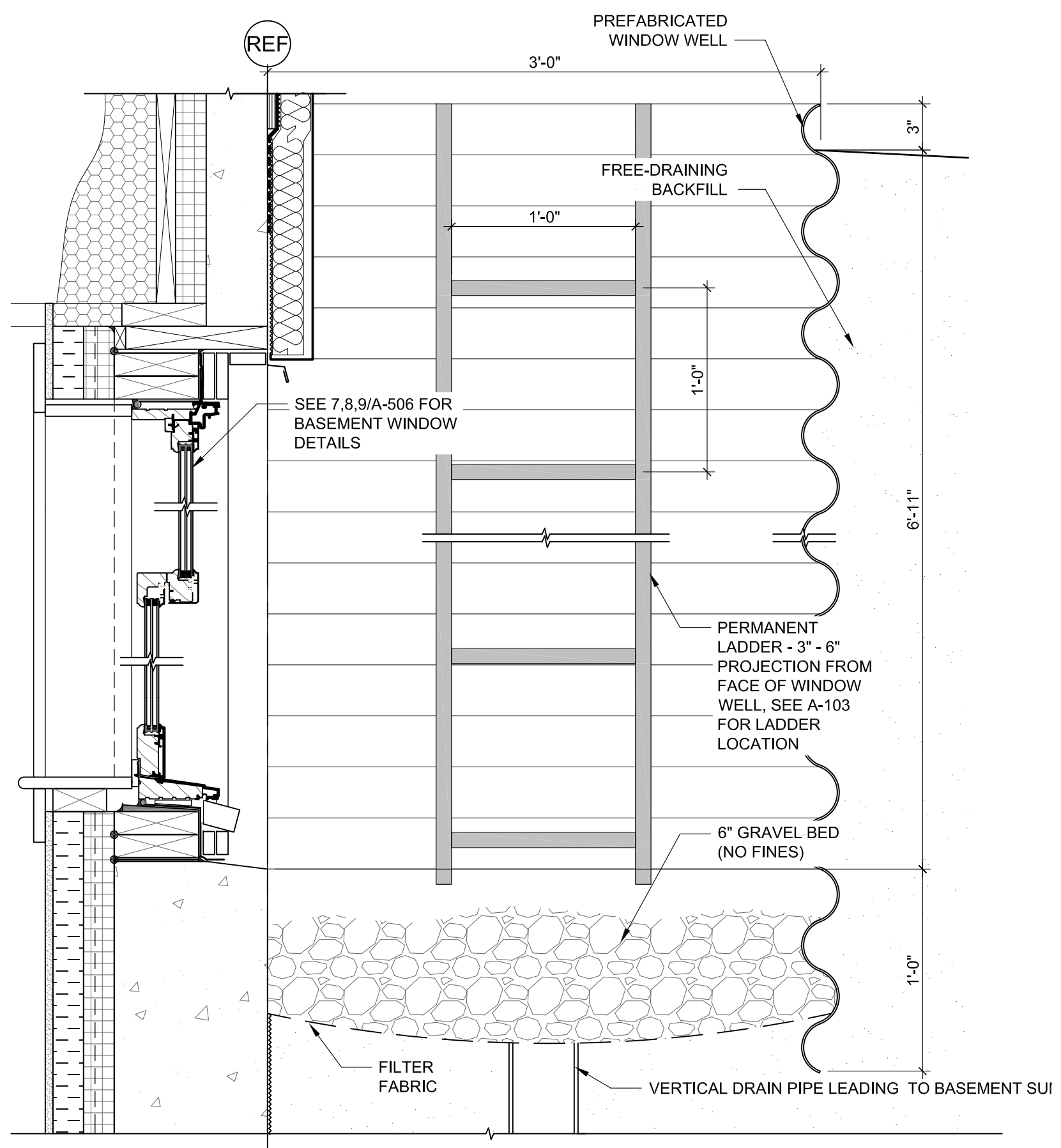

**6 WINDOW WELL DETAIL**  
SCALE: 1 1/2" = 1'-0"

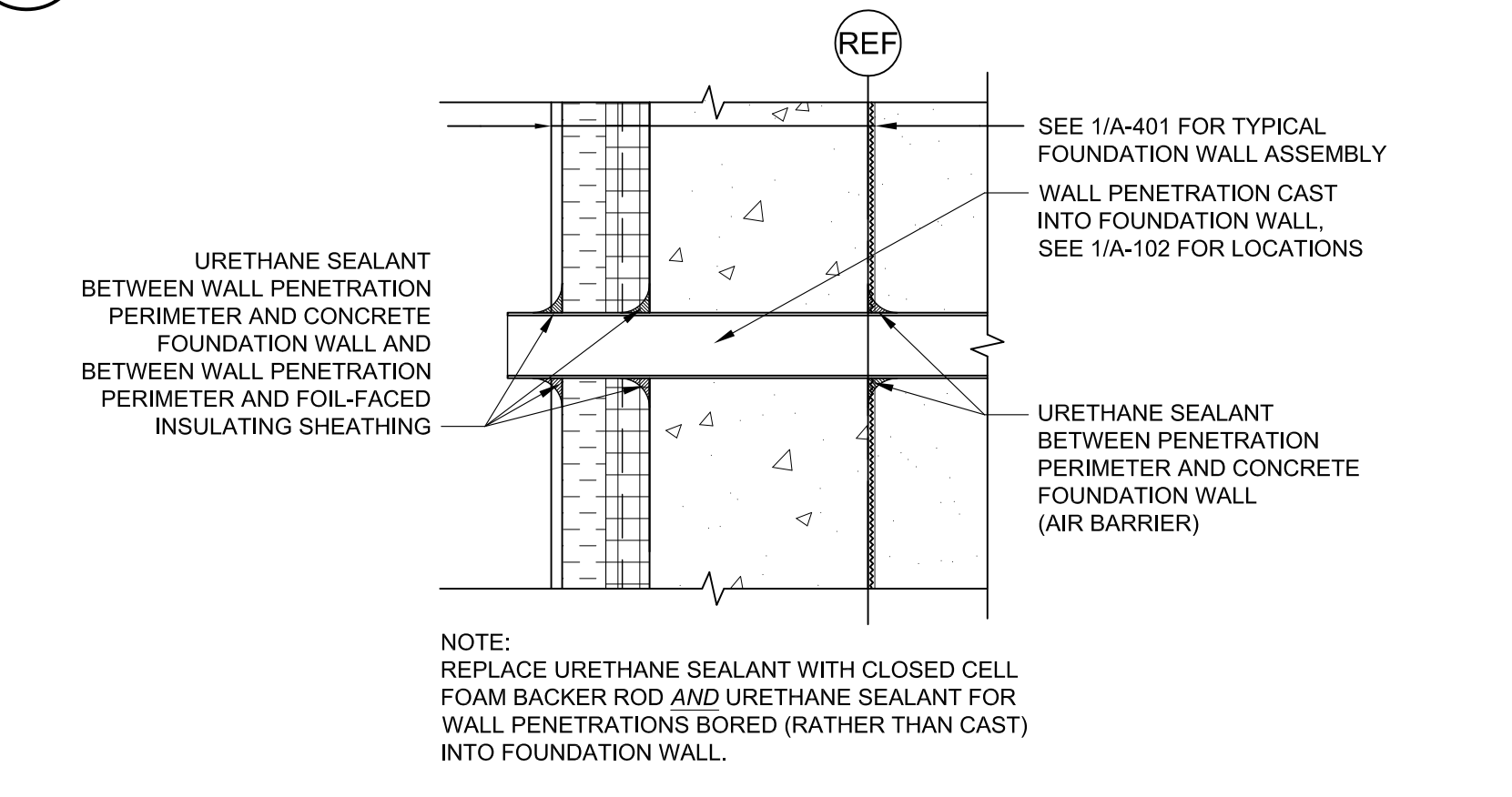

**5 WALL PENETRATION DETAIL**  
SCALE: 1 1/2" = 1'-0"

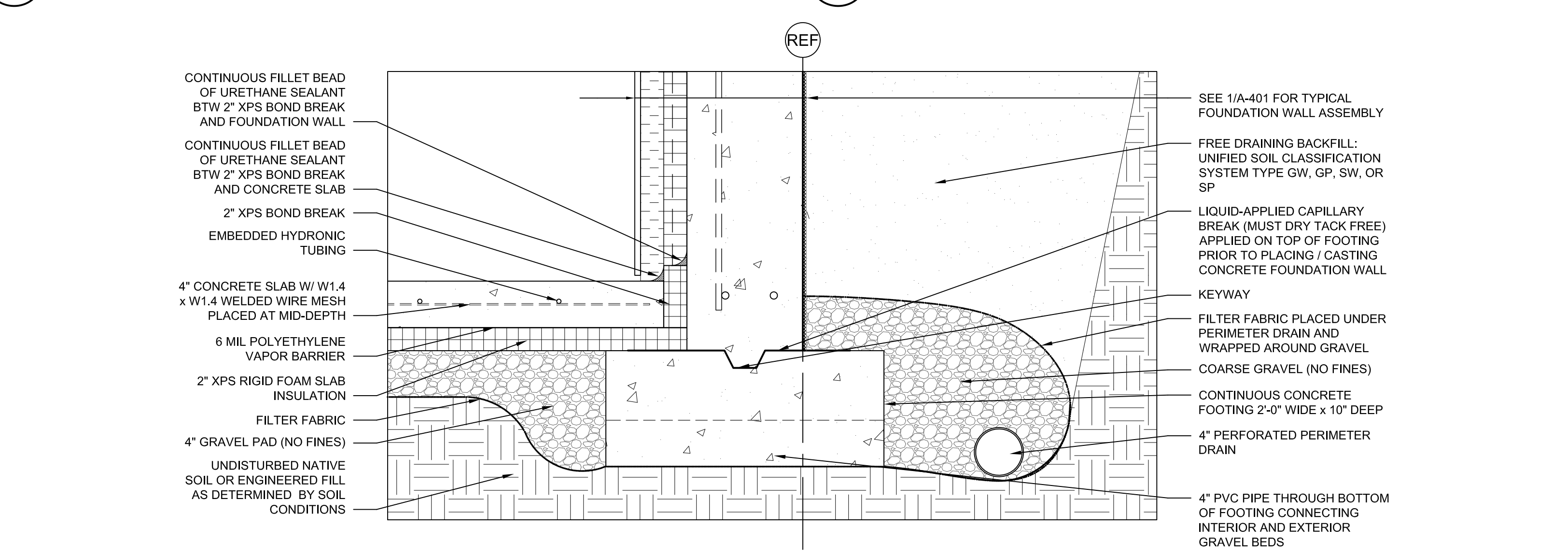

**1 BOTTOM OF FOUNDATION WALL DETAIL**  
SCALE: 1 1/2" = 1'-0"

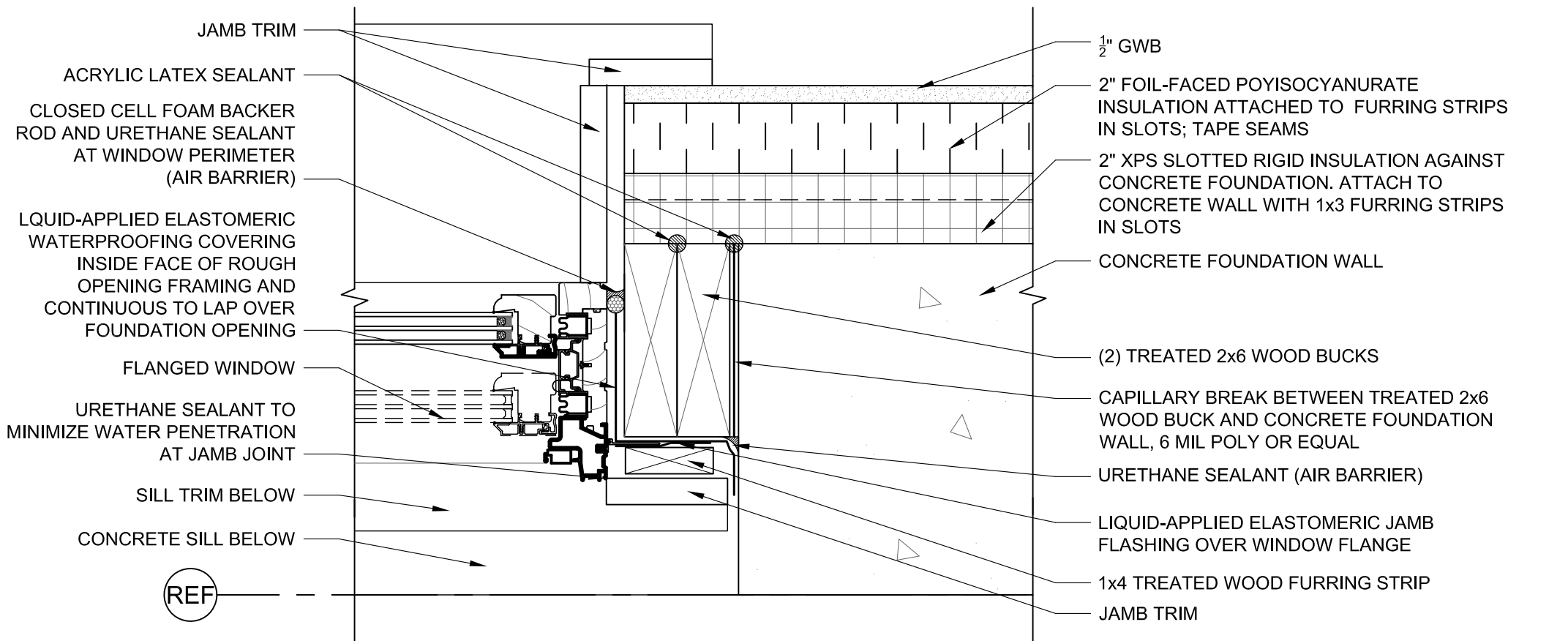

**9 BASEMENT WINDOW JAMB DETAIL**  
SCALE: 3" = 1'-0"

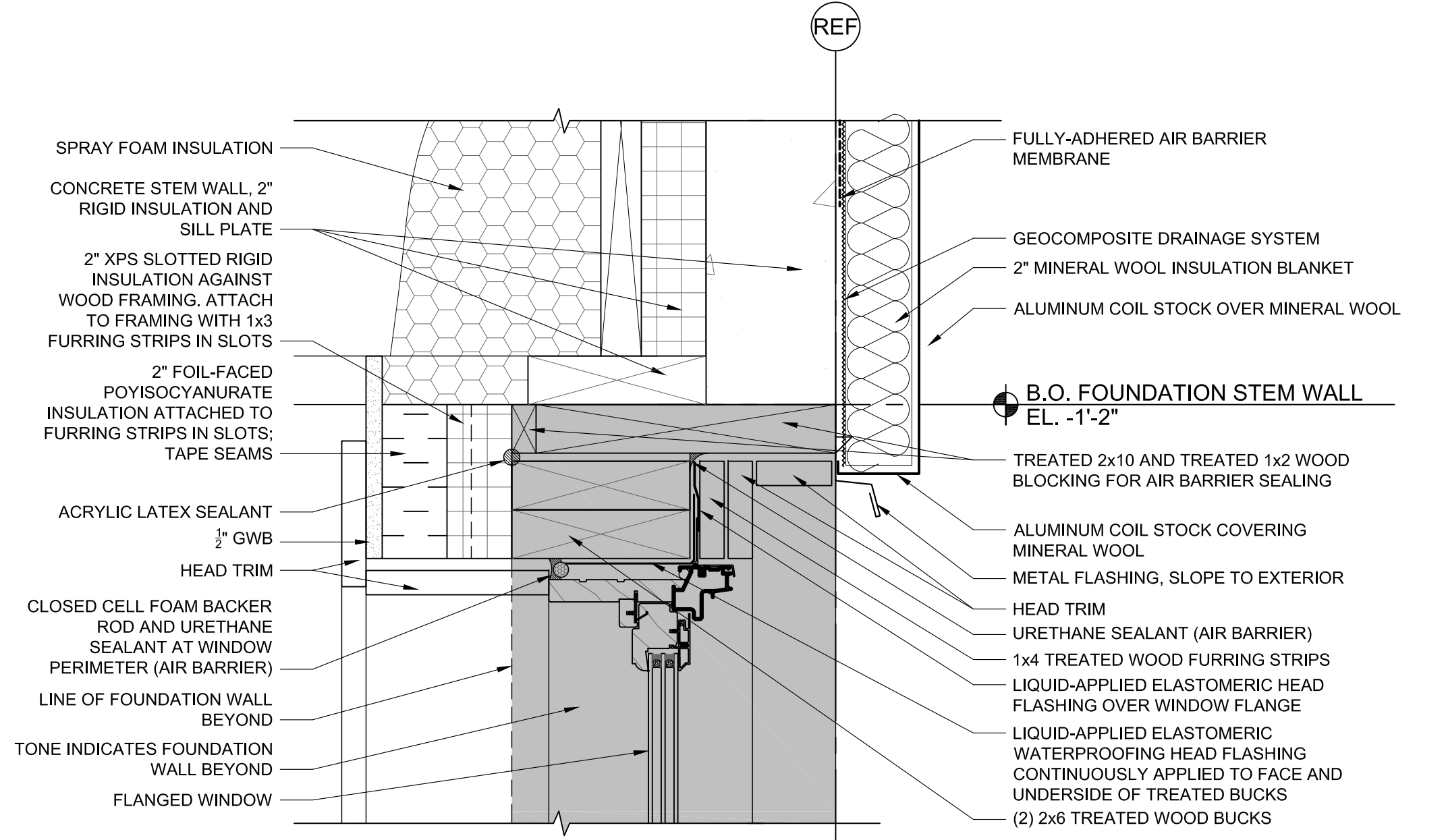

**8 BASEMENT WINDOW HEAD DETAIL**  
SCALE: 3" = 1'-0"

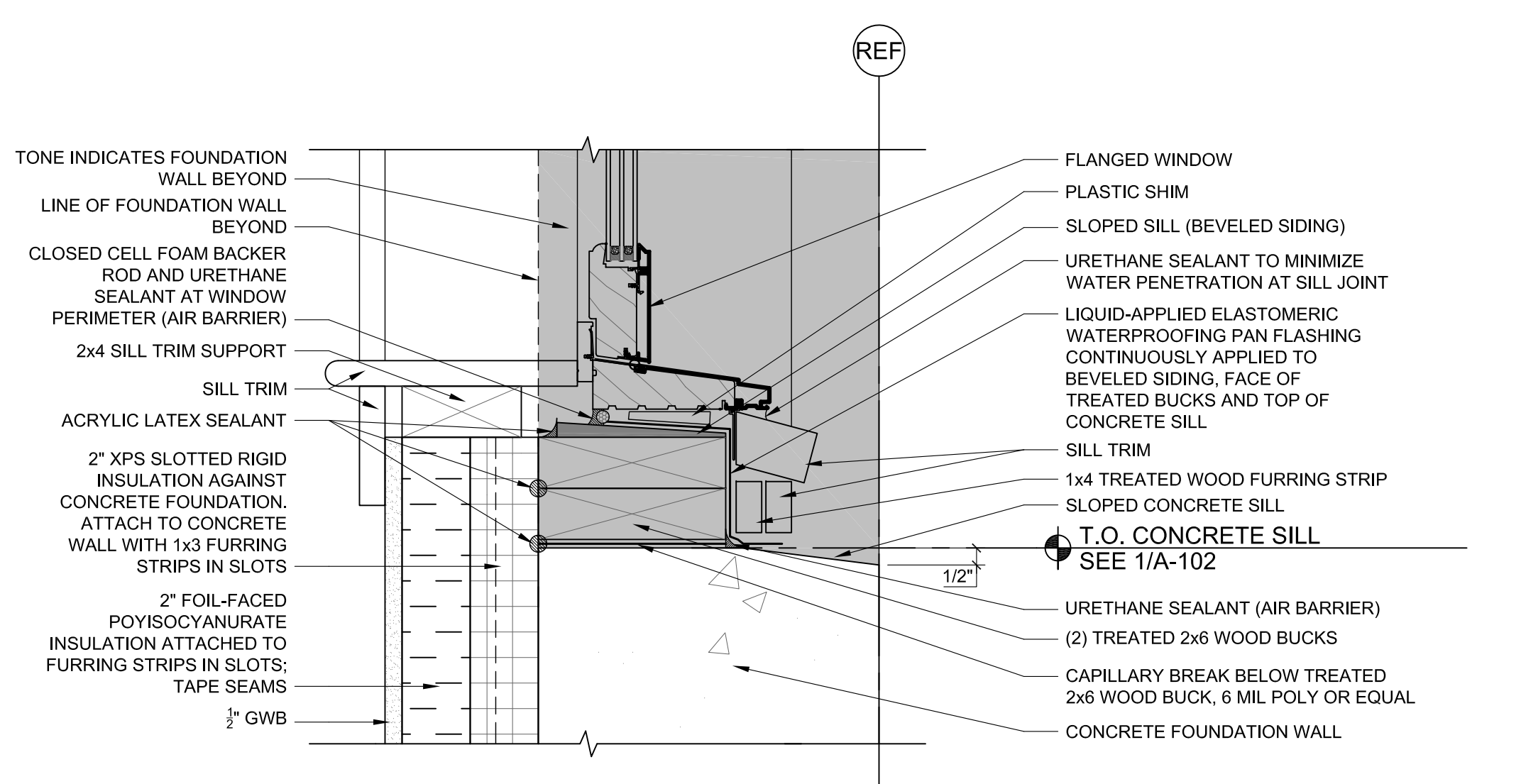

**7 BASEMENT WINDOW SILL DETAIL**  
SCALE: 3" = 1'-0"



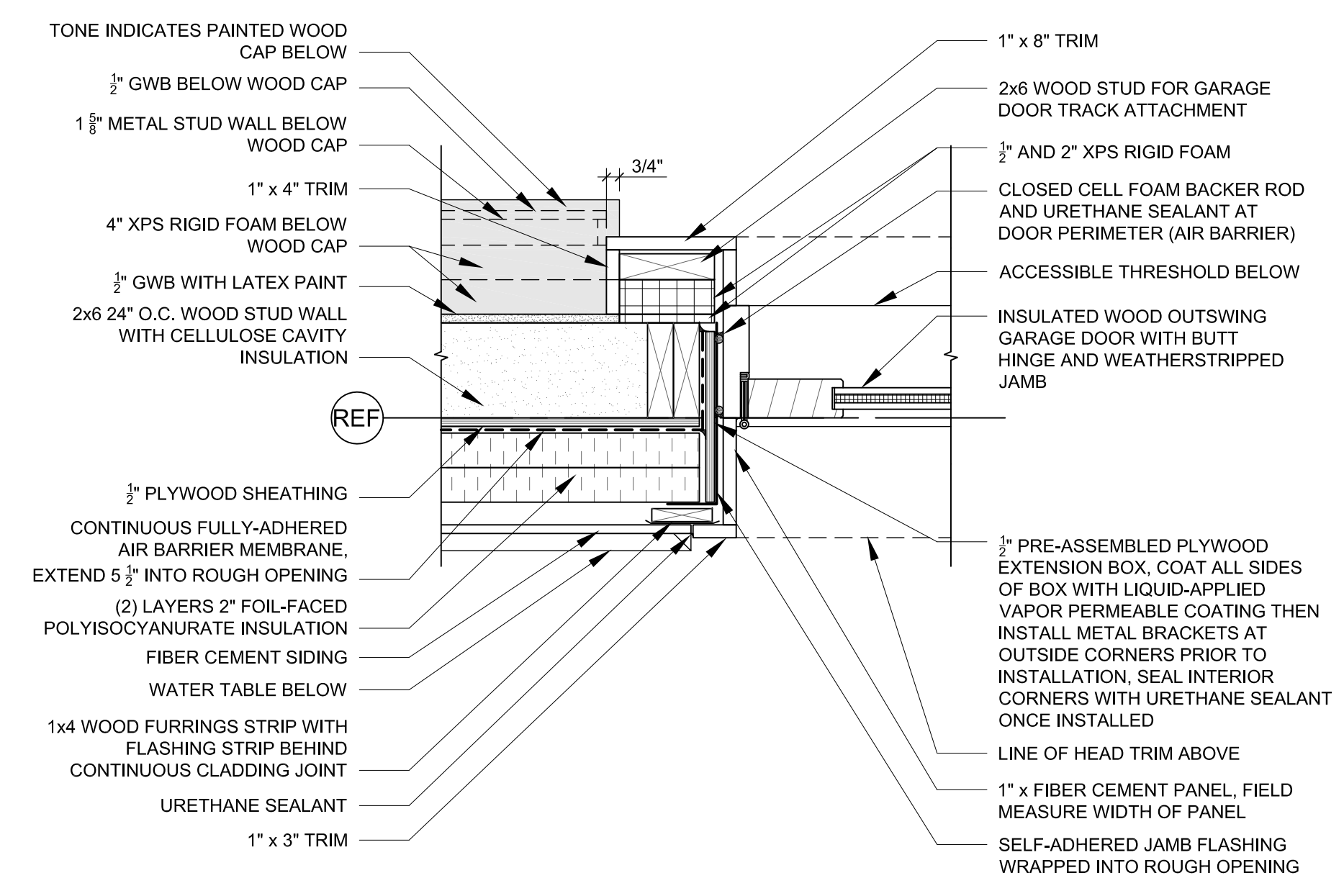

**6** OUTSWING GARAGE DR. JAMB DETAIL AT SIDING  
SCALE: 1 1/2" = 1'-0"

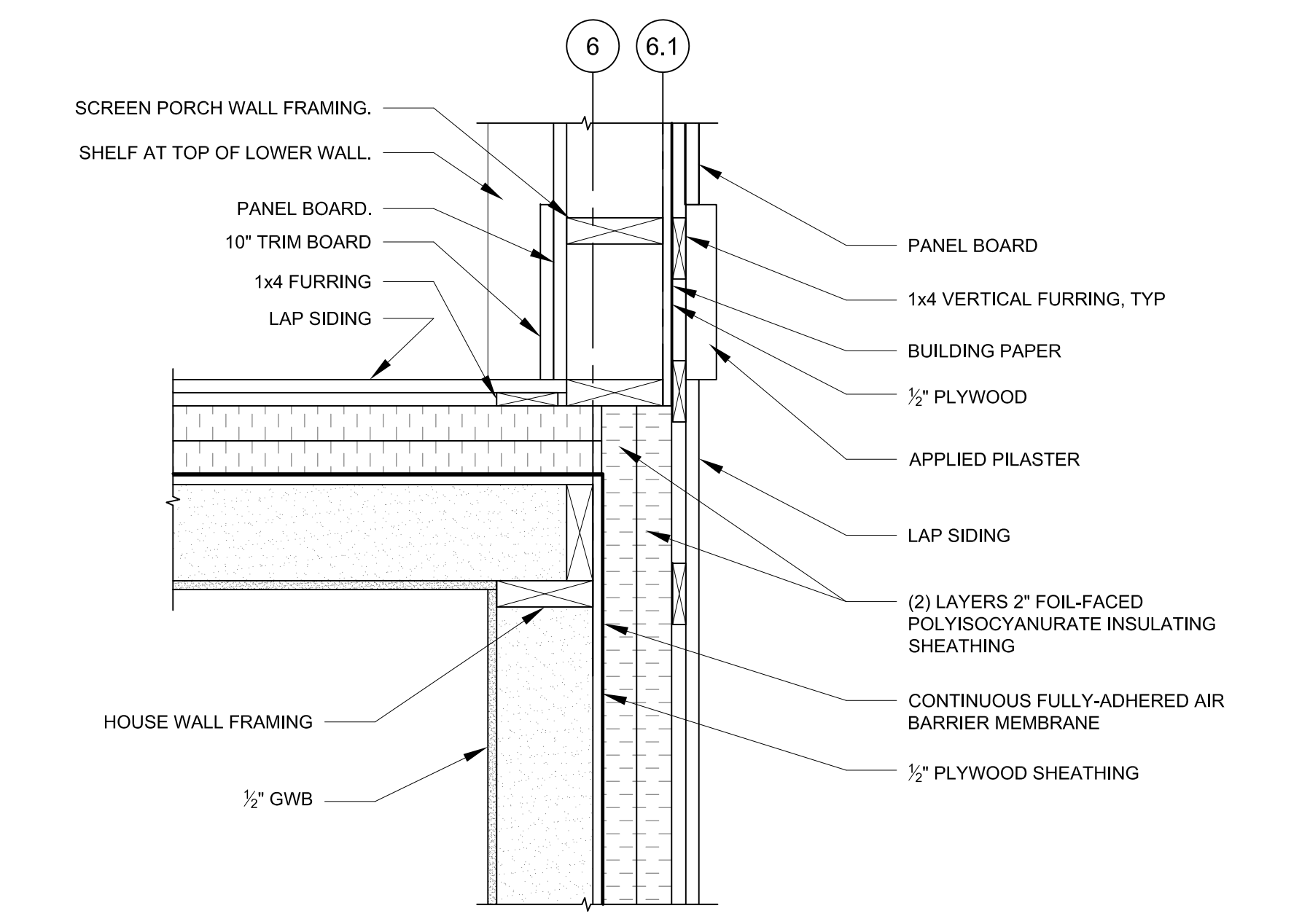

**3** OUTSIDE CORNER DETAIL AT SCREEN PORCH  
SCALE: 1 1/2" = 1'-0"

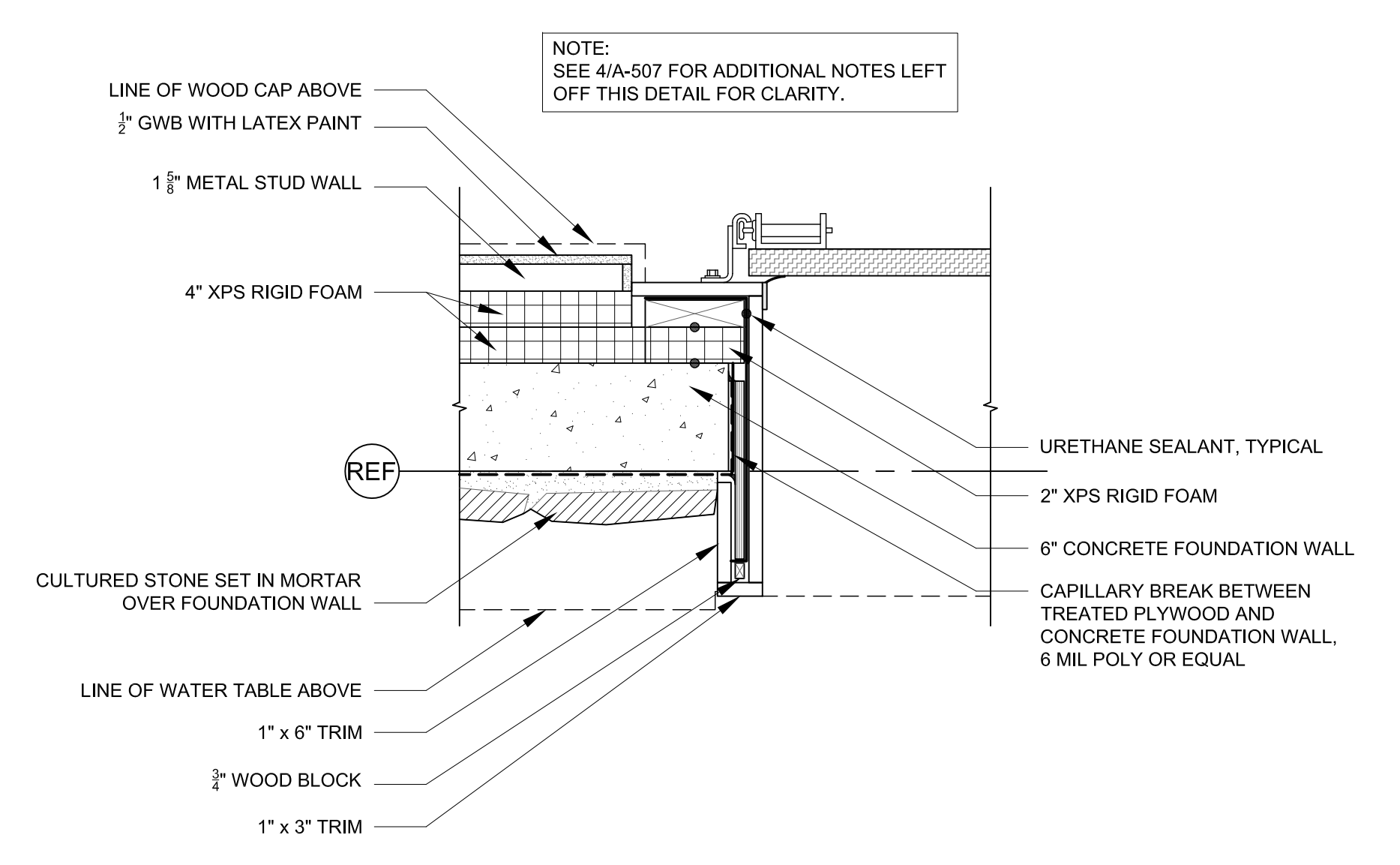

**5** OVERHEAD GARAGE DR. JAMB DETAIL AT STONE  
SCALE: 1 1/2" = 1'-0"

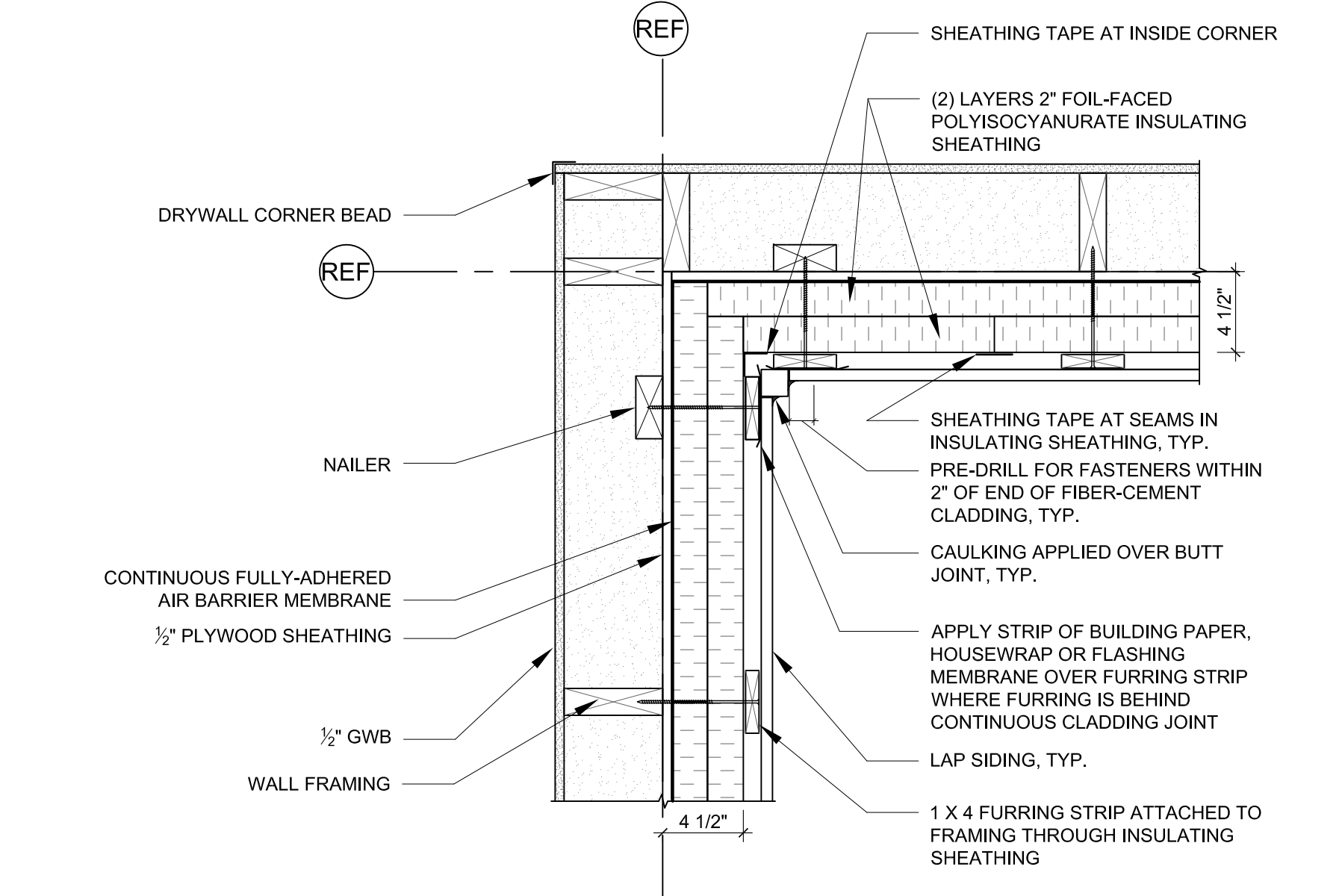

**2** INSIDE CORNER DETAIL  
SCALE: 1 1/2" = 1'-0"

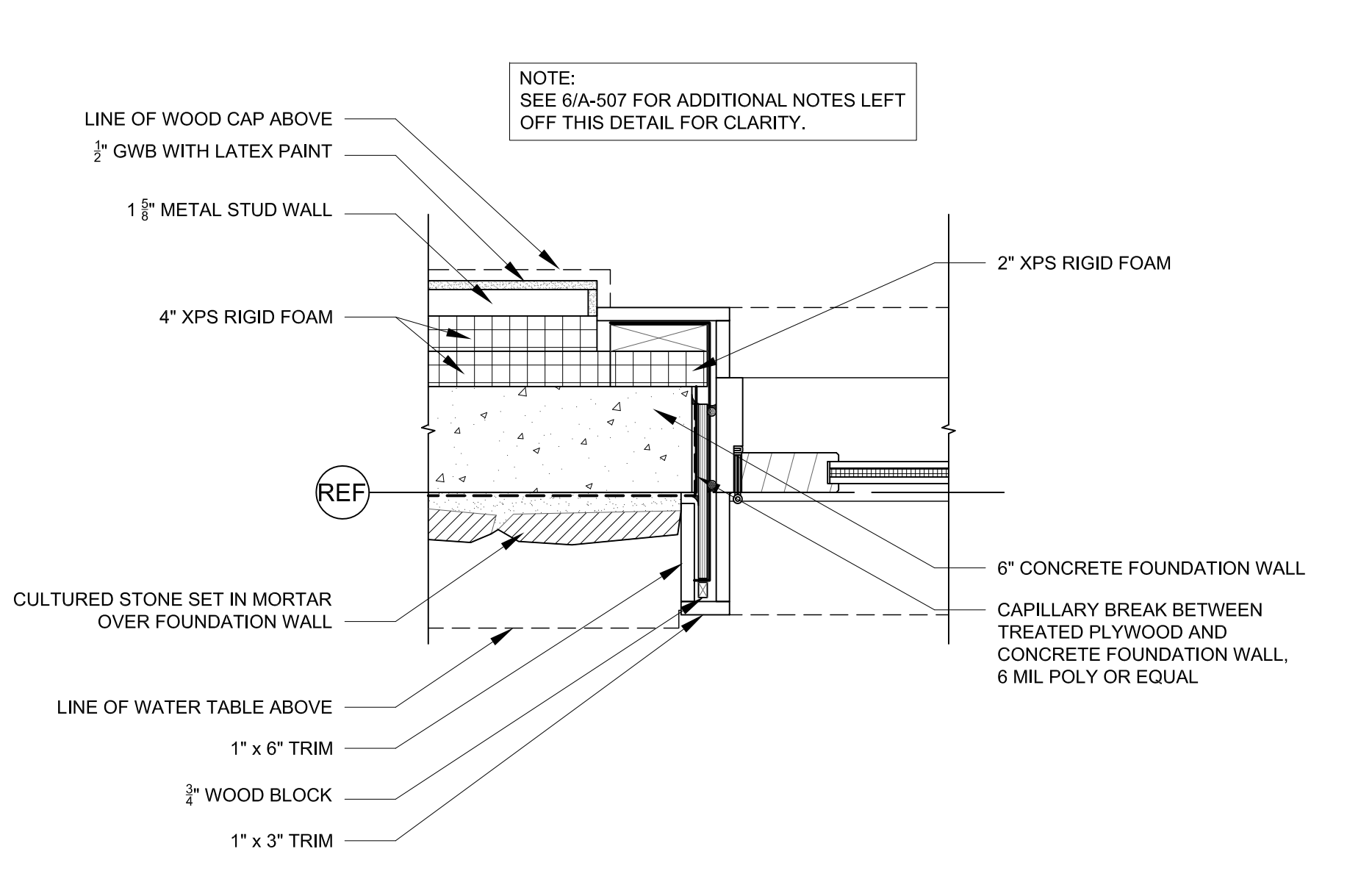

**7** OUTSWING GARAGE DR. JAMB DETAIL AT STONE  
SCALE: 1 1/2" = 1'-0"

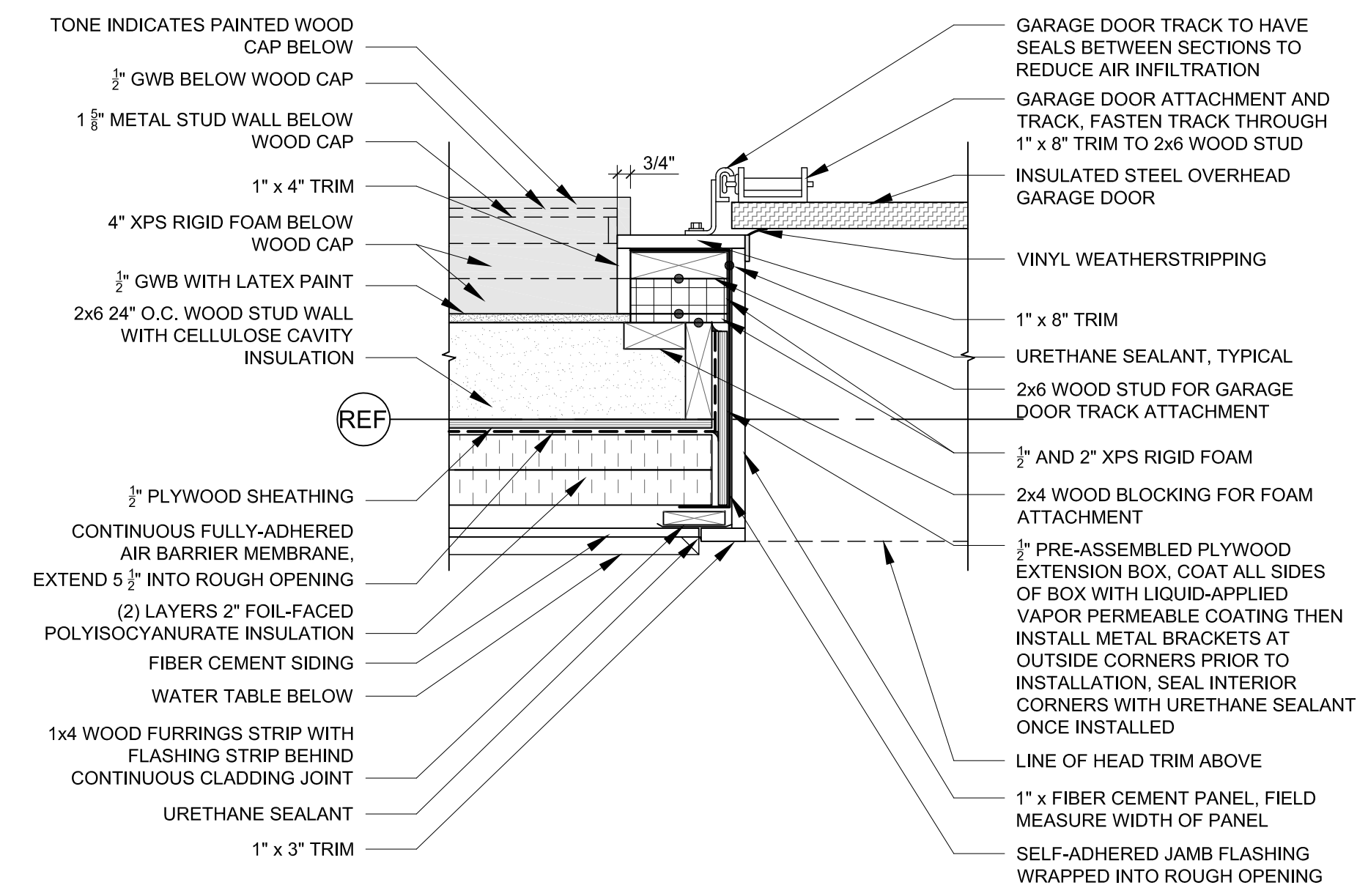

**4** OVERHEAD GARAGE DR. JAMB DETAIL AT SIDING  
SCALE: 1 1/2" = 1'-0"

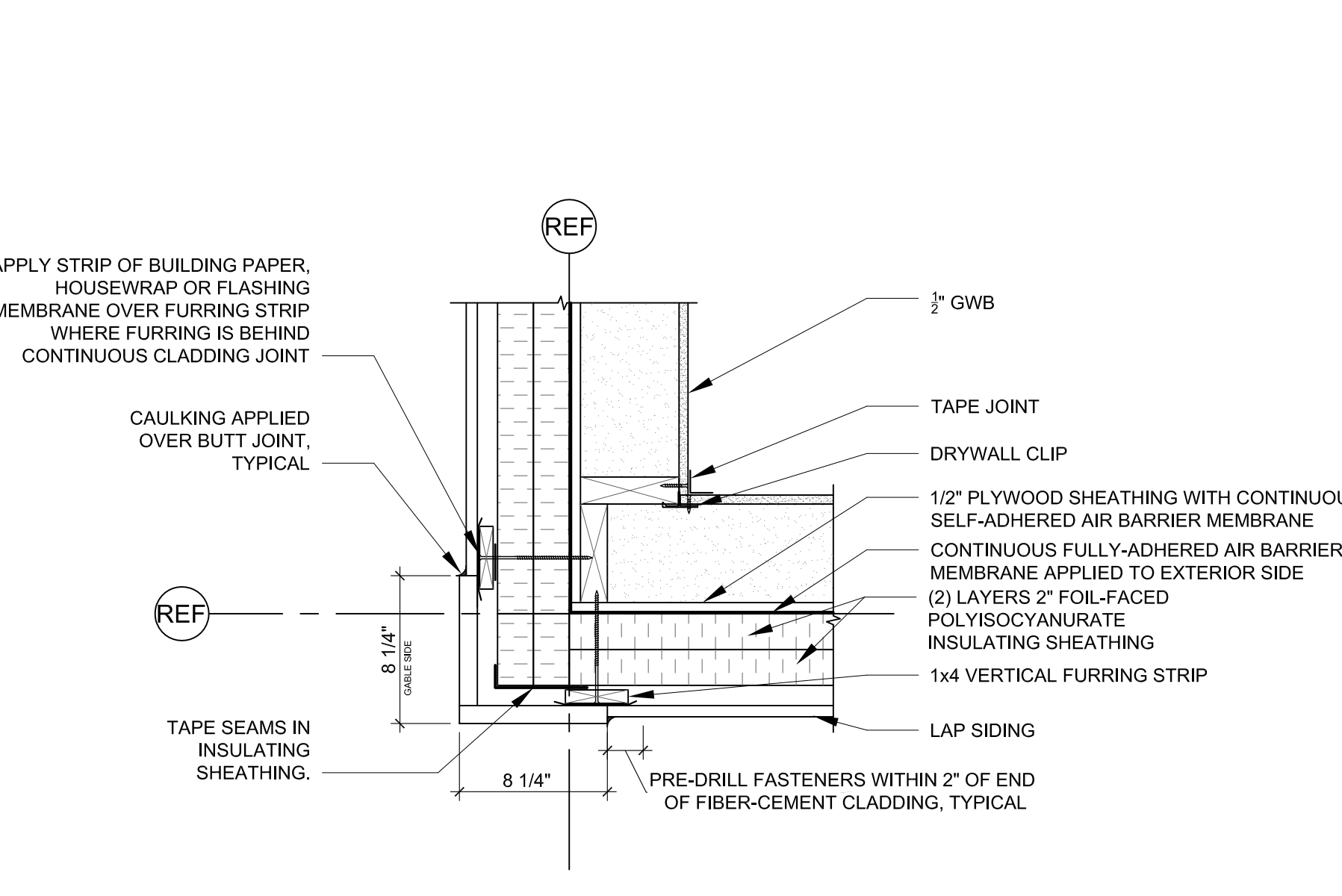

**1** OUTSIDE CORNER DETAIL  
SCALE: 1 1/2" = 1'-0"



CONSULTANT:

PROJECT:  
National Institute of  
Standards and Technology  
**NET ZERO ENERGY  
RESIDENTIAL TEST  
FACILITY**  
NIST Campus  
Gaithersburg, MD



MARK	DATE	DESCRIPTION
ISSUE:	03/31/10	ISSUED FOR CONSTRUCTION

PROJECT NO: NIST NZERTF  
CAD DWG FILE: A-PLOT-DET-NZERTF  
DRAWN BY: CG  
CHECKED BY: BP  
COPYRIGHT © 2009  
BUILDING SCIENCE CORPORATION

SHEET TITLE:  
**HORIZONTAL  
DETAILS**

SCALE AS NOTED



CONSULTANT:

PROJECT:

National Institute of Standards and Technology

**NET ZERO ENERGY RESIDENTIAL TEST FACILITY**

NIST Campus  
Gaithersburg, MD



U.S. DEPARTMENT OF ENERGY | Energy Efficiency & Renewable Energy

MARK	DATE	DESCRIPTION
ISSUE:	03/31/10	ISSUED FOR CONSTRUCTION

PROJECT NO: NIST NZERTF  
CAD DWG FILE: A-PL0T-DETL-NZERTF  
DRAWN BY: CG  
CHECKED BY: BP

COPYRIGHT © 2009  
BUILDING SCIENCE CORPORATION

SHEET TITLE:

**VERTICAL DETAILS**

SCALE AS NOTED

**A-508**

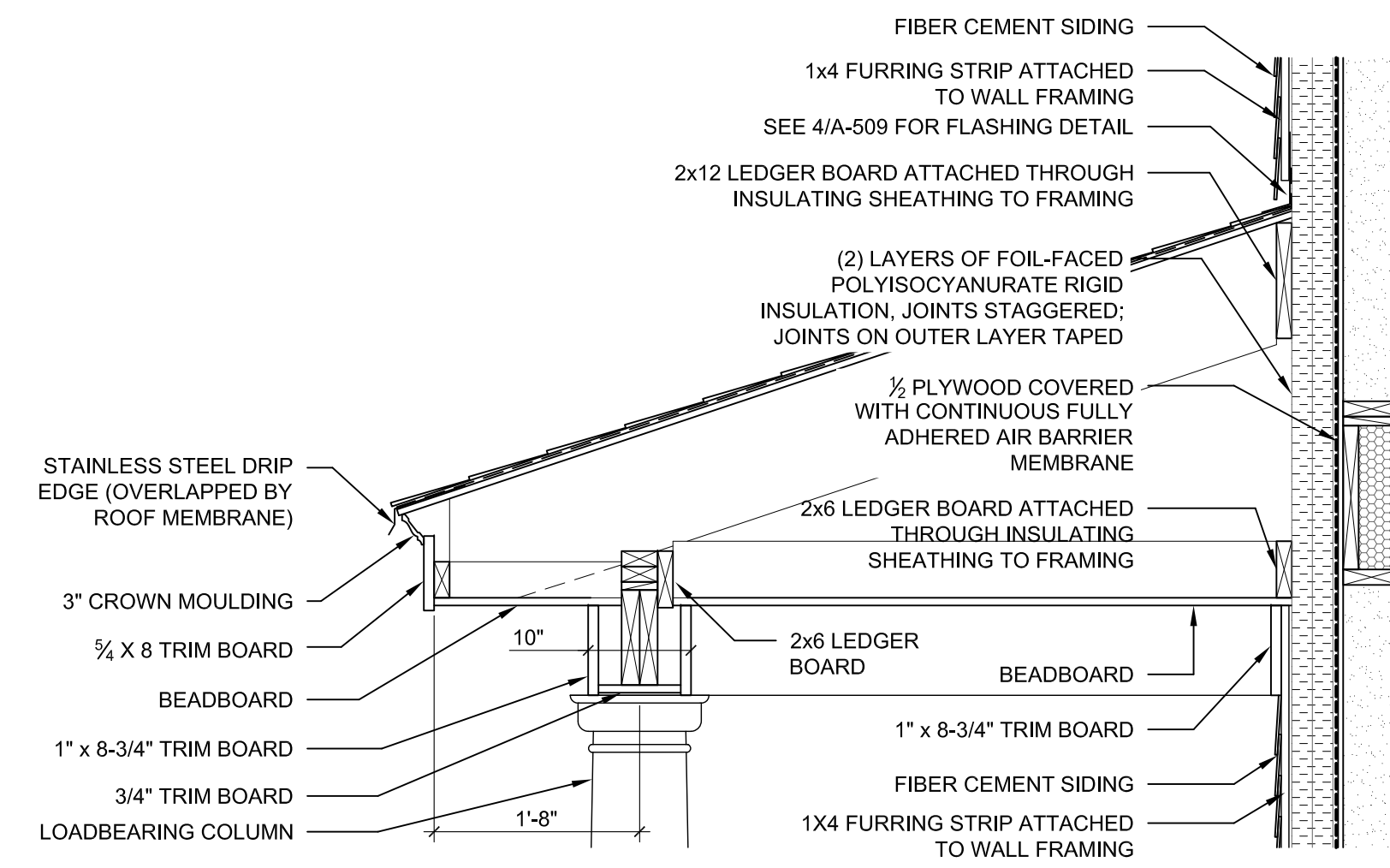

**6 FRONT PORCH ROOF DETAIL**  
SCALE: 3/4" = 1'-0"

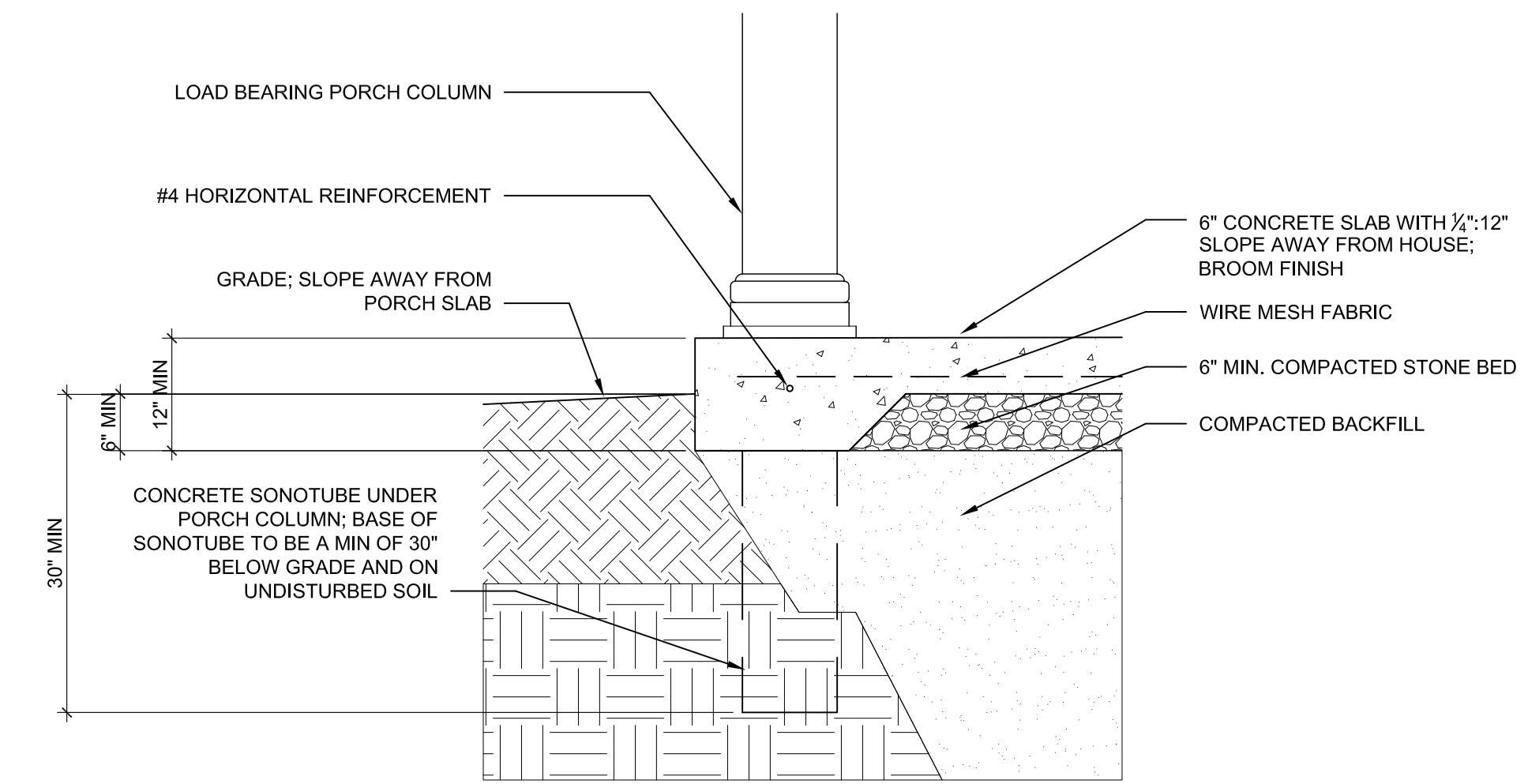

**3 FRONT PORCH/BREEZEWAY FOUNDATION DETAIL**  
SCALE: 3/4" = 1'-0"

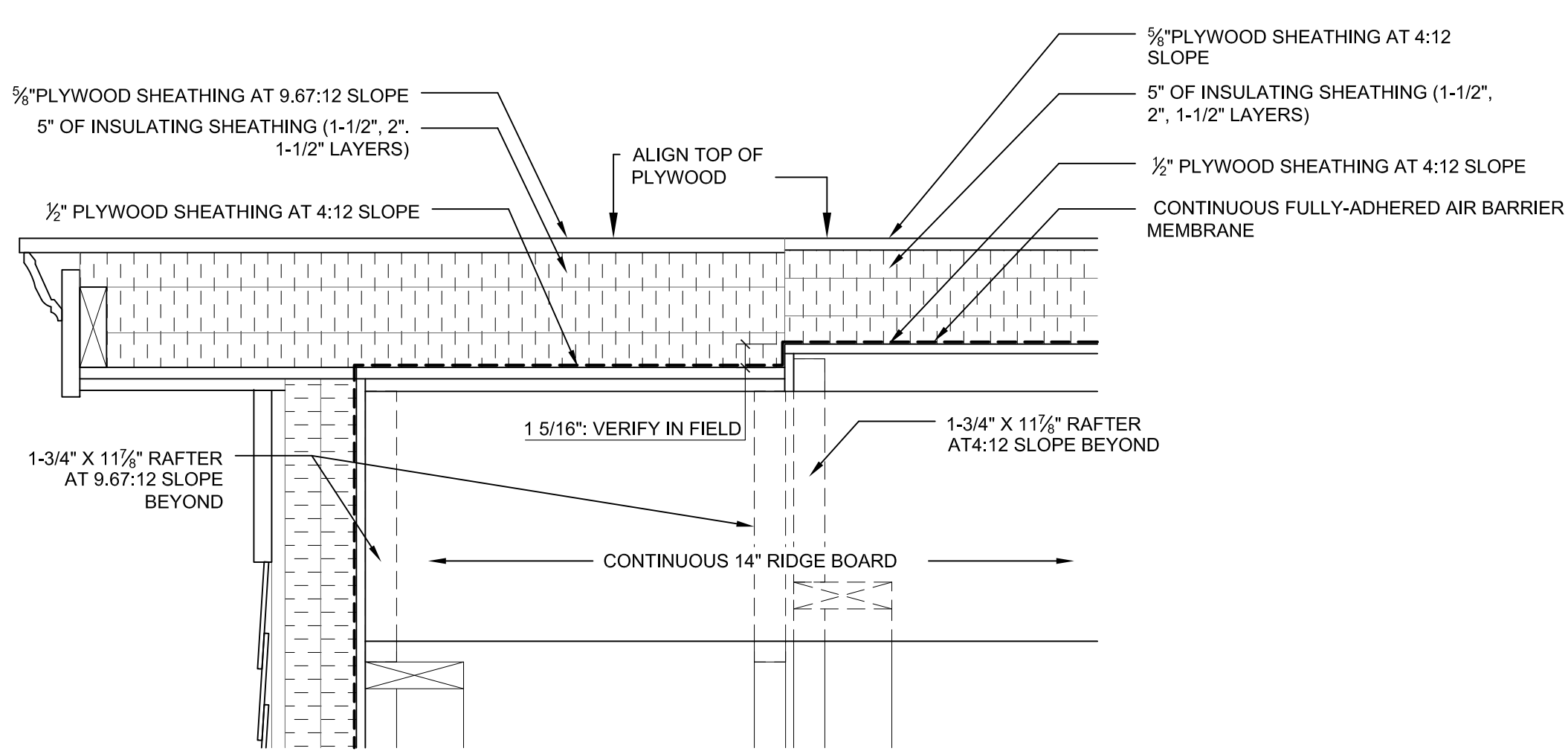

**5 SECTION AT RIDGE OF HOUSE**  
SCALE: 1 1/2" = 1'-0"

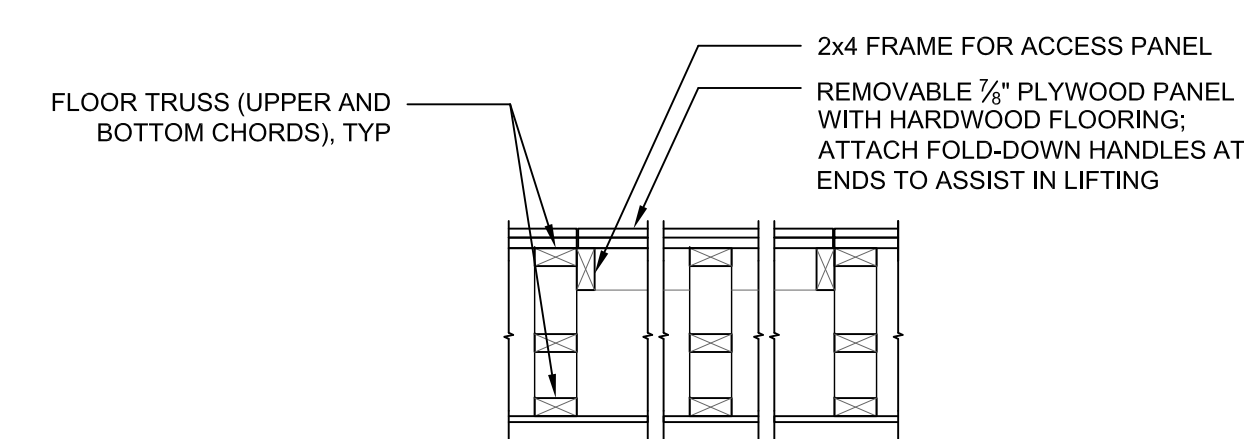

**8 TYP. DETAIL AT FLOOR ACCESS PANEL**  
SCALE: 3/4" = 1'-0"

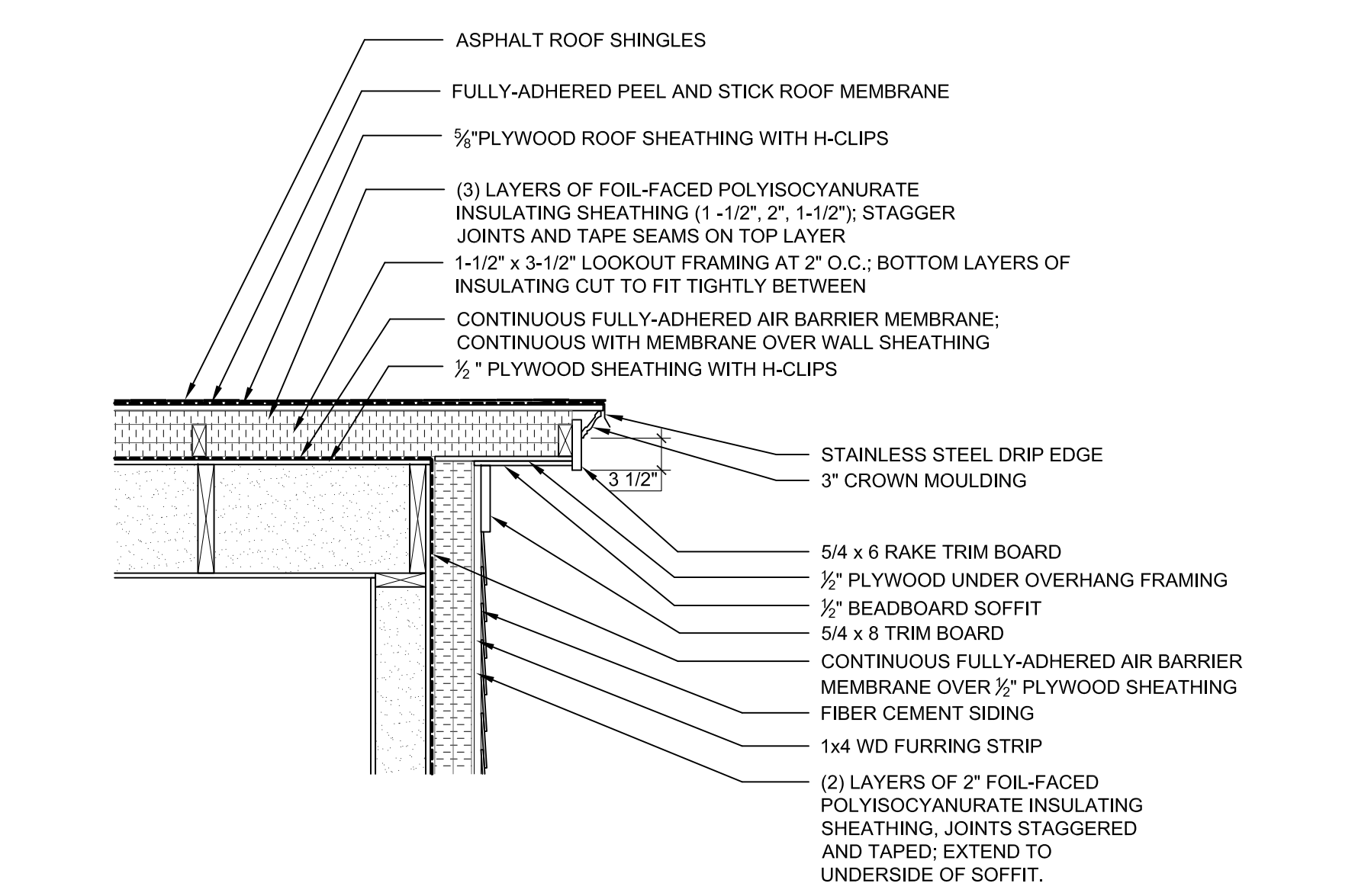

**2 TYPICAL DETAIL AT RAKE**  
SCALE: 3/4" = 1'-0"

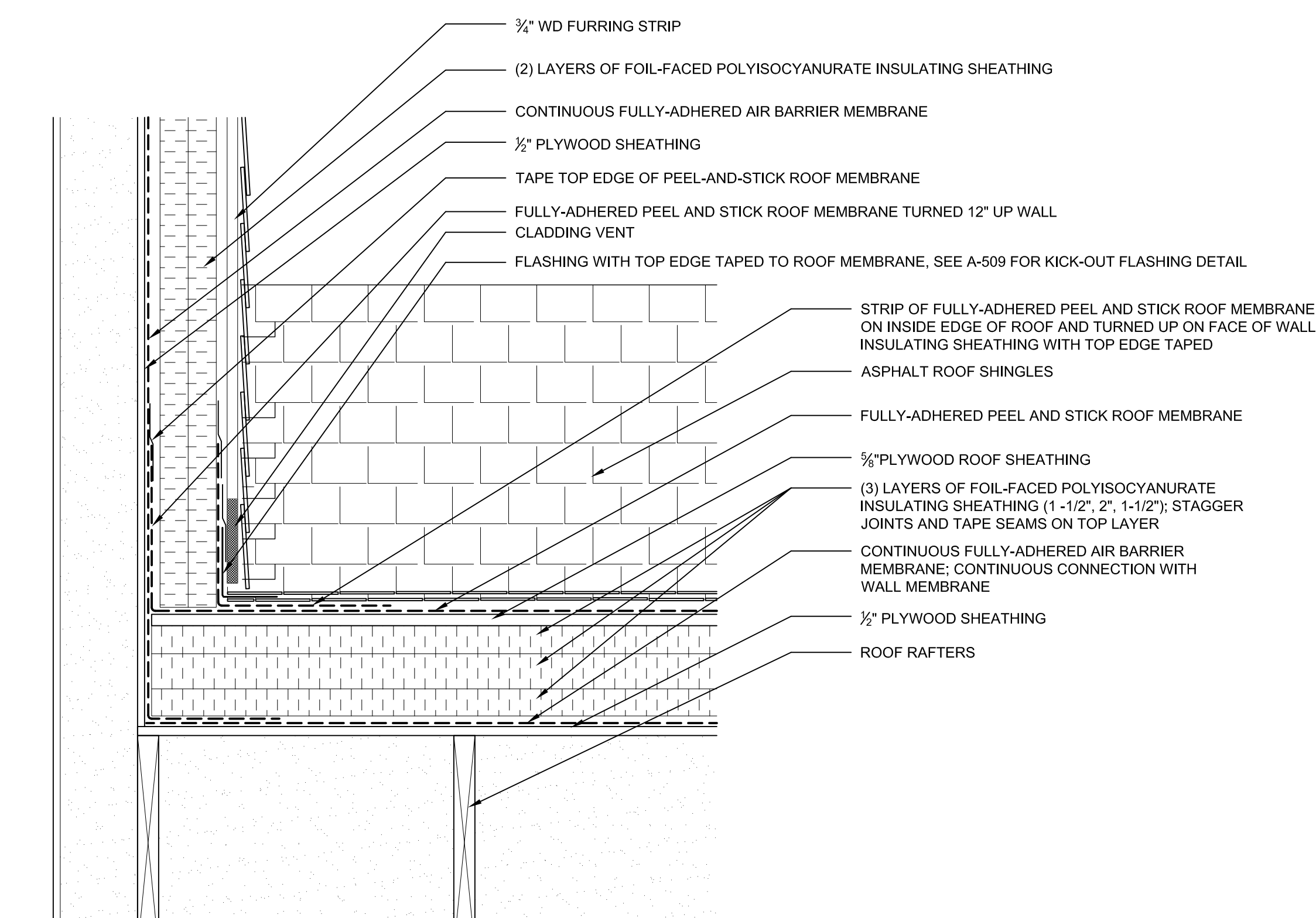

**4 SECTION AT ROOF (PARALLEL) TO WALL CONNECTION**  
SCALE: 1 1/2" = 1'-0"

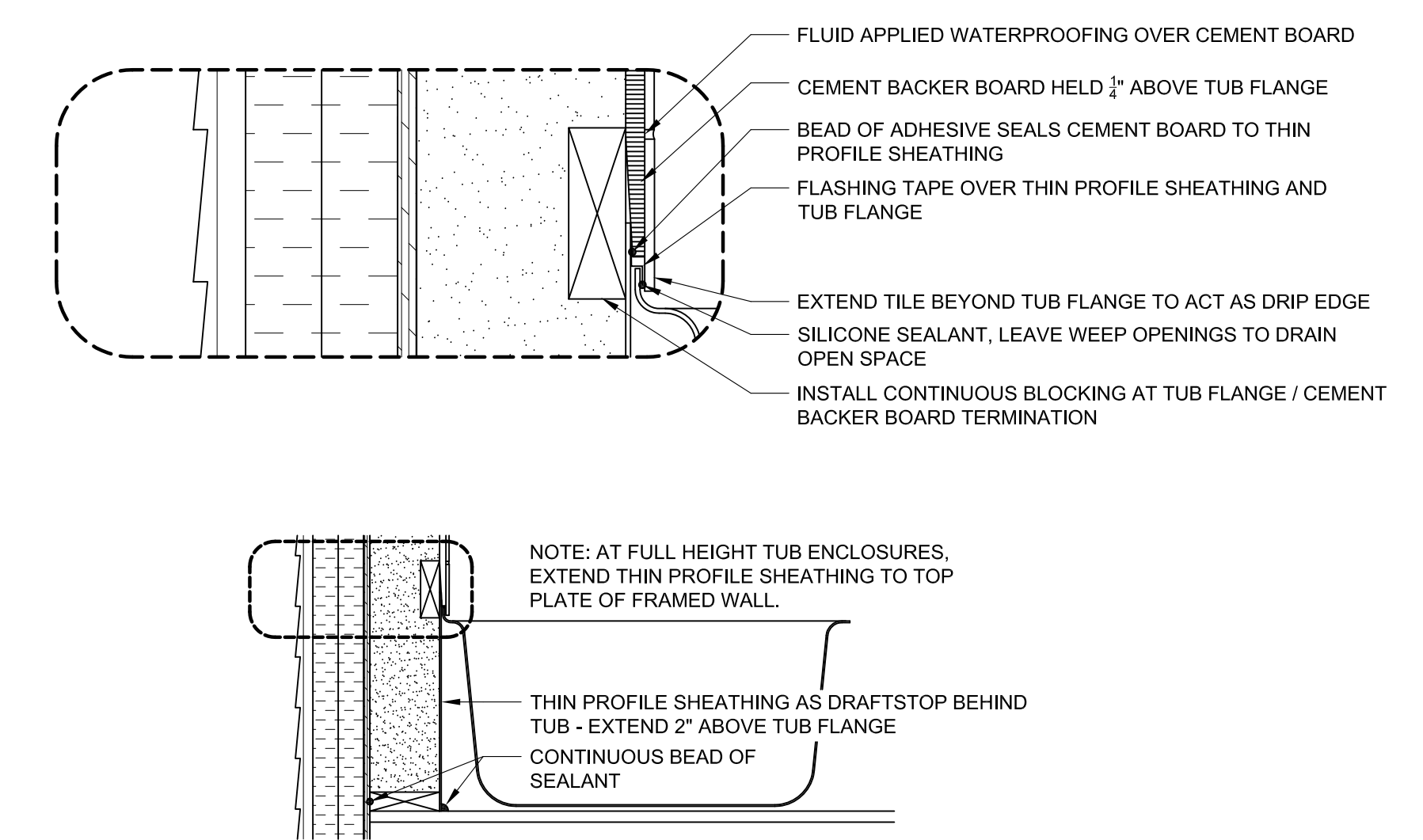

**1 BATHTUB & SHOWER AT EXTERIOR WALL DETAIL**  
SCALE: 1" = 1'-0" BOTTOM, 3" = 1'-0" TOP

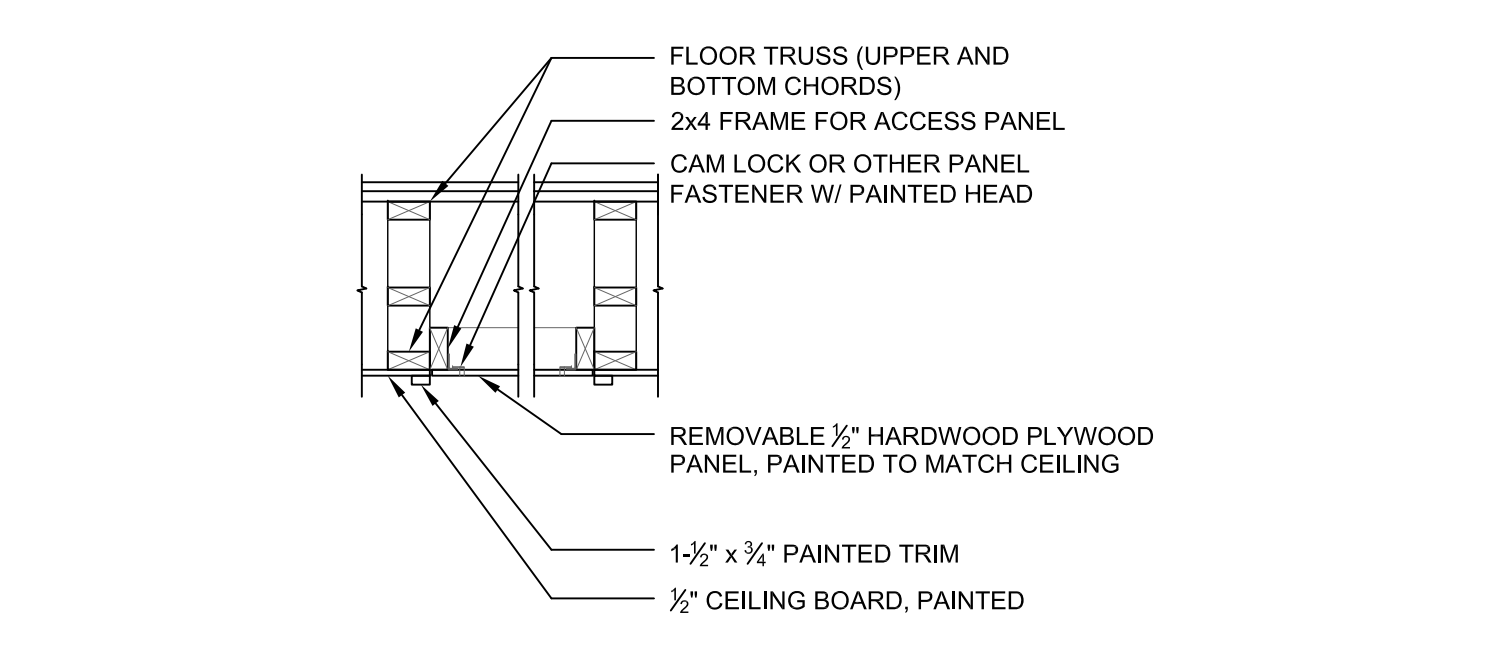

**7 TYP. DETAIL AT CEILING ACCESS PANEL**  
SCALE: 3/4" = 1'-0"





CONSULTANT:

PROJECT:

National Institute of Standards and Technology

**NET ZERO ENERGY RESIDENTIAL TEST FACILITY**

NIST Campus Gaithersburg, MD



U.S. DEPARTMENT OF ENERGY | Energy Efficiency & Renewable Energy



MARK	DATE	DESCRIPTION
ISSUE:	03/31/10	ISSUED FOR CONSTRUCTION

PROJECT NO:	NIST NZERTF
CAD DWG FILE:	A-PLOT-DETL-NZERTF
DRAWN BY:	KG
CHECKED BY:	BP

COPYRIGHT © 2009 BUILDING SCIENCE CORPORATION  
SHEET TITLE:

**ROOF DETAILS**

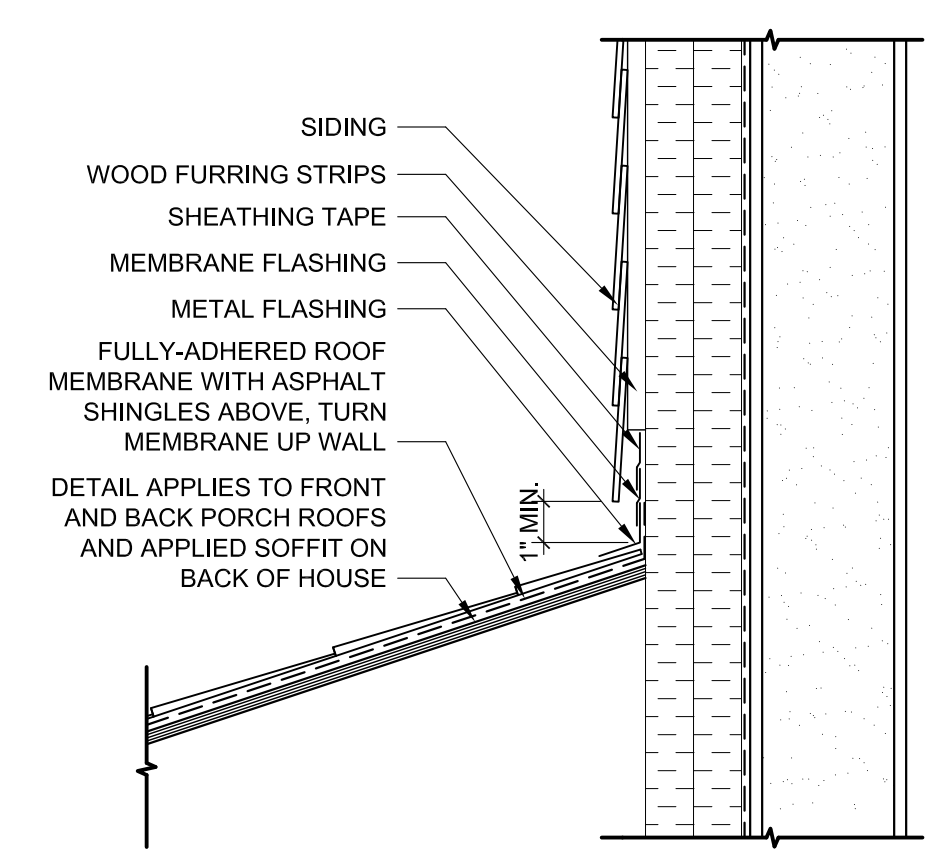
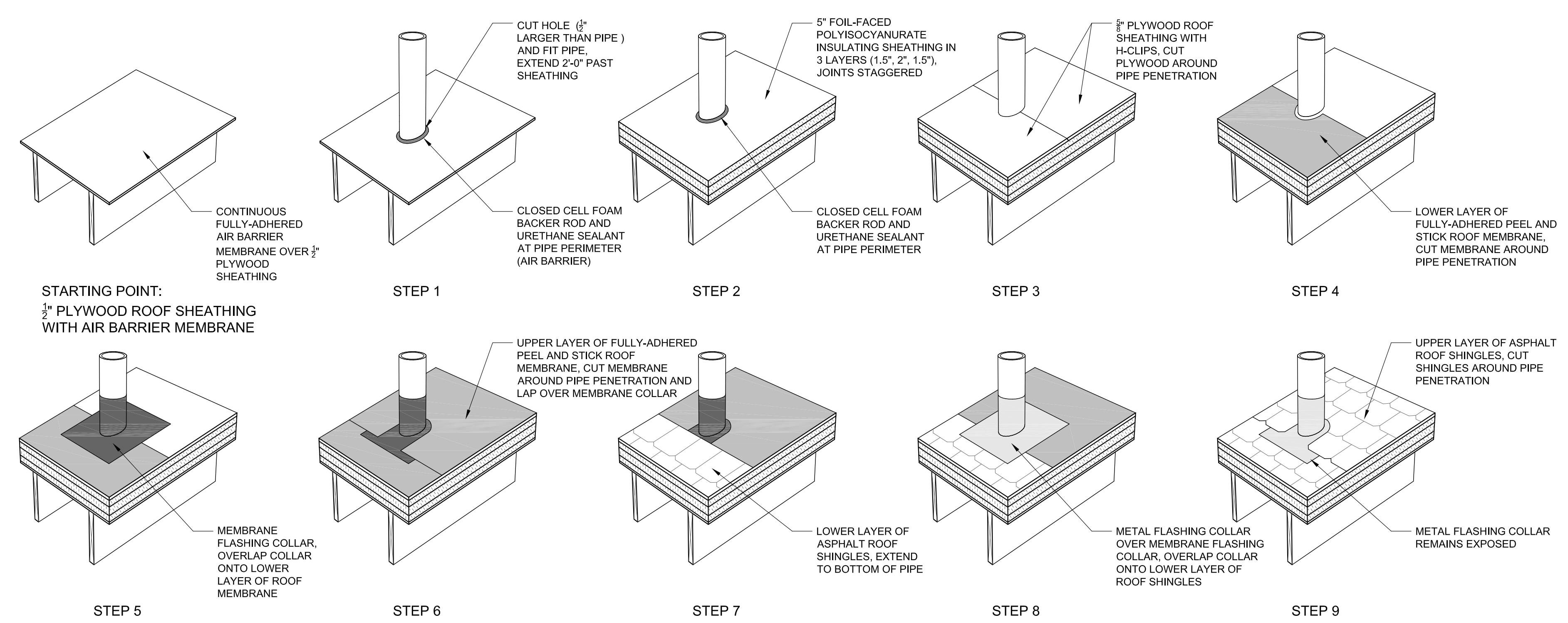
SCALE AS NOTED



**5 ROOF PENETRATION INSTALLATION SEQUENCE**  
SCALE: N.T.S.

**4 SLOPED ROOF-TO-WALL FLASHING DETAIL**  
SCALE: 1 1/2" = 1'-0"

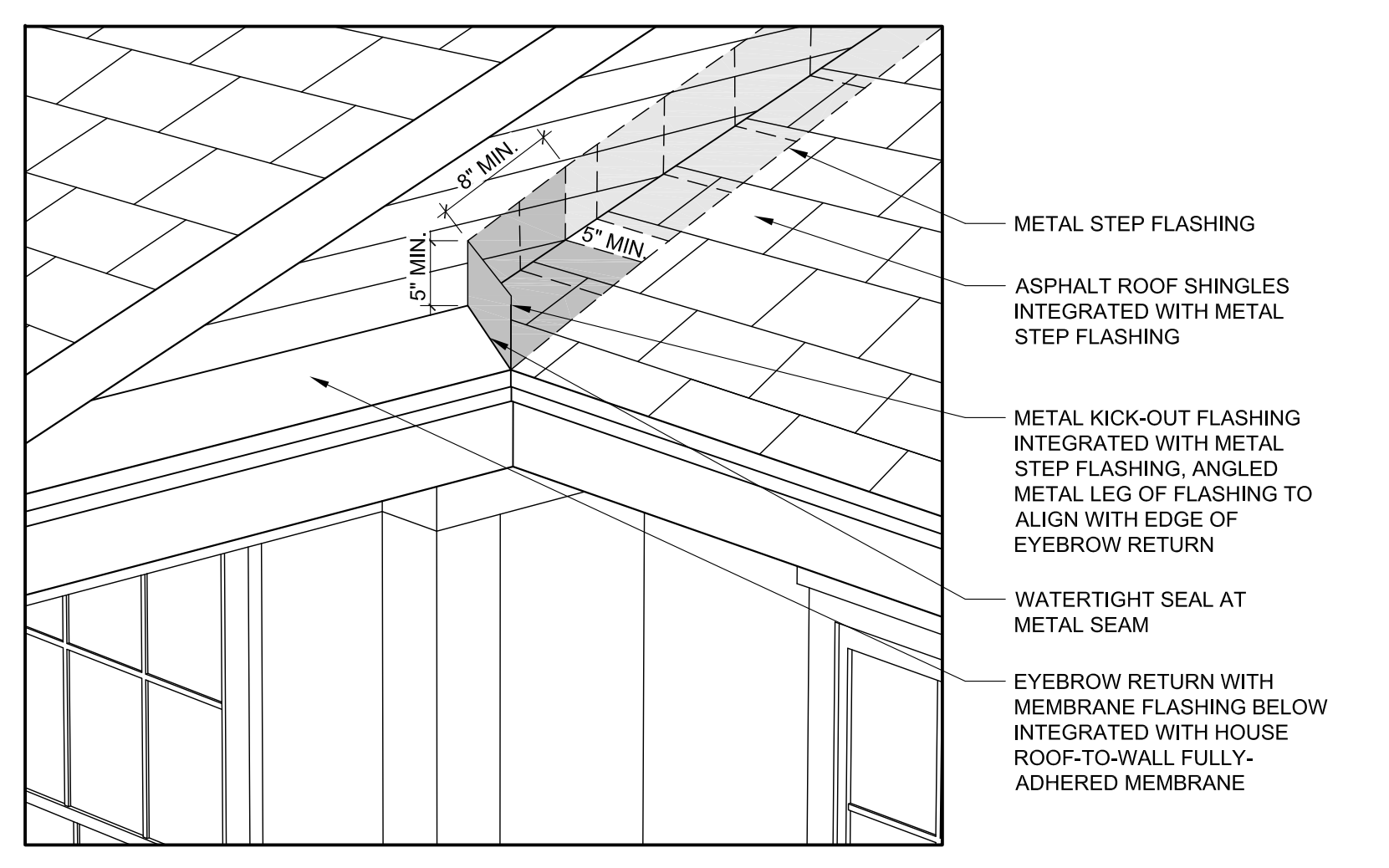

**3 KICK-OUT FLASHING DETAIL**  
SCALE: N.T.S.

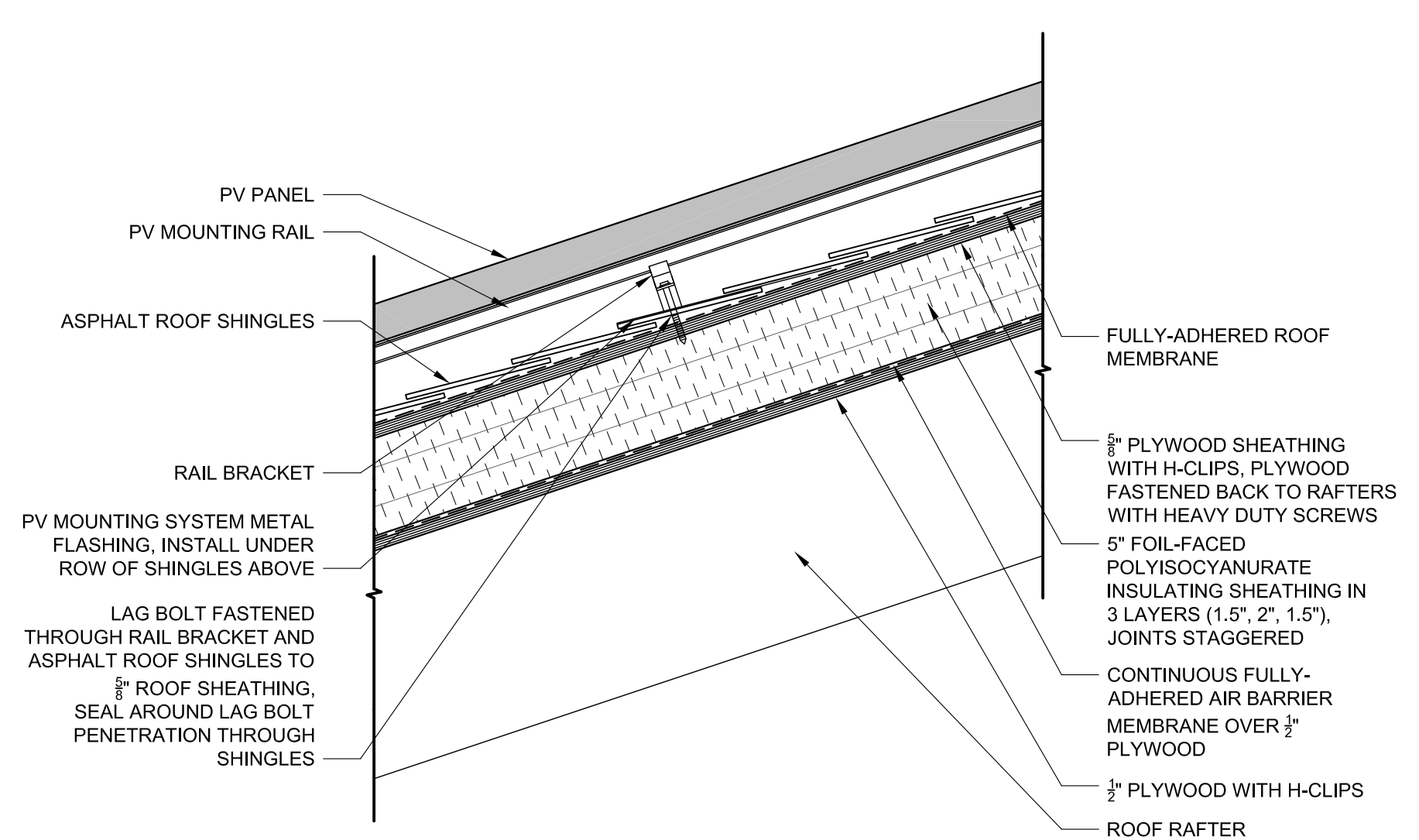

**2 PV MOUNTING SYSTEM DETAIL**  
SCALE: 1 1/2" = 1'-0"

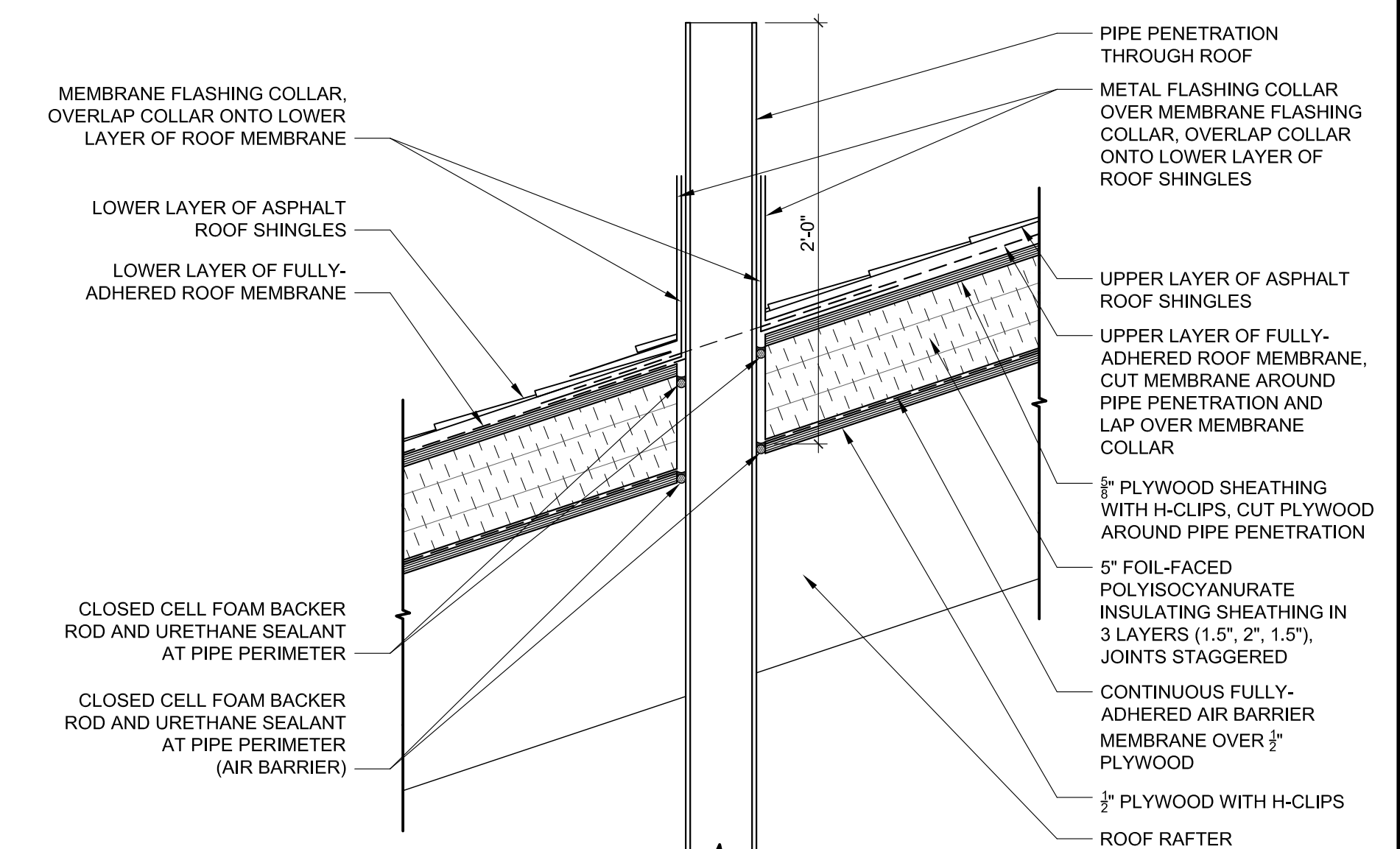

**1 ROOF PENETRATION SECTION DETAIL**  
SCALE: 1 1/2" = 1'-0"

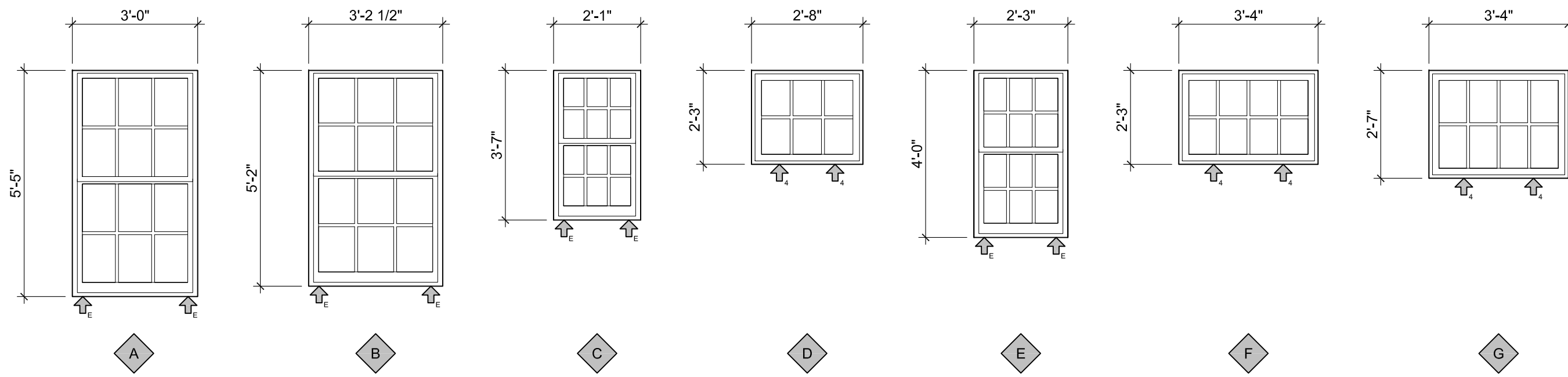

= SHIM AT QUARTER PTS. OF SILL  
 = SHIM NEAR END OF SILL

WINDOW SCHEDULE *							
TYPE	FRAME SIZE	TYPE	MATERIAL	GLAZING	MEETS EGRESS REQ.	QTY	NOTES
A	3'-0" x 5'-5"	DOUBLE HUNG	FIBERGLASS	SUPER-INSUL CLR LOW E	YES	13	1, 4, 5, 7, 8
B	3'-2 1/2" x 5'-2"	DOUBLE HUNG	FIBERGLASS	SUPER-INSUL CLR LOW E	YES	7	1, 3, 6, 7, 8
C	2'-1" x 3'-7"	DOUBLE HUNG	FIBERGLASS	SUPER-INSUL CLR LOW E	NO	2	1, 8
D	2'-8" x 2'-3"	AWNING	FIBERGLASS	SUPER-INSUL CLR LOW E	NO	2	1, 8
E	2'-3" x 4'-0"	DOUBLE HUNG	FIBERGLASS	SUPER-INSUL CLR LOW E	NO	4	1, 2, 8
F	3'-4" x 2'-3"	AWNING	FIBERGLASS	SUPER-INSUL CLR LOW E	NO	2	1, 8
G	3'-4" x 2'-7"	AWNING	FIBERGLASS	SUPER-INSUL CLR LOW E	NO	2	1, 8

- NOTES:
1. SIMULATED DIVIDED LITE.
  2. BATH #1 AND MASTER BATH WINDOWS TO HAVE TEMPERED GLASS.
  3. BASEMENT WINDOW TO HAVE TEMPERED GLASS.
  4. WINDOW IN BEDROOM 4 (SOUTHEAST CORNER) TO HAVE TEMPERED GLASS.
  5. WINDOW TYPE "A" TO MEET 2009 IRC SECTION R310 REQUIREMENTS FOR EMERGENCY ESCAPE AND RESCUE OPENINGS FOR GRADE FLOOR ONLY. BEDROOM 4 TO HAVE (1) WINDOW MEETING THESE REQUIREMENTS.
  6. WINDOW TYPE "B" TO MEET 2009 IRC SECTION R310 REQUIREMENTS FOR EMERGENCY ESCAPE AND RESCUE OPENINGS. BASEMENT WINDOW, BEDROOM 2, BEDROOM 3 AND MASTER BEDROOM ALL TO HAVE (1) WINDOW MEETING THESE REQUIREMENTS.
  7. SPECIFIED WINDOWS MEET EGRESS REQUIREMENTS.
  8. SEE SPECIFICATIONS FOR WINDOW MANUFACTURER, WINDOW TYPE AND WINDOW AND GLAZING PERFORMANCE SPECIFICATIONS.

\* SEE 7/A-503 FOR WINDOW INSTALLATION SEQUENCE.

DOOR SCHEDULE ** ***							
TYPE	SIZE	LOCATION	TYPE	MATERIAL	HINGE	QTY	NOTES
1	1'-8" x 6'-8"	INTERIOR	SWING	SOLID CORE	LH	2	1, 12, 16
2	(2) 1'-10" x 6'-8"	INTERIOR	DOUBLE SWING	SOLID CORE	-	3	1, 12, 16
3	2'-4" x 6'-8"	INTERIOR	SWING	SOLID CORE	LH	2	1, 12, 16
4	2'-4" x 6'-8"	INTERIOR	SWING	SOLID CORE	RH	3	1, 12, 16
5	2'-4" x 6'-8"	INTERIOR	POCKET	SOLID CORE	-	1	1, 12, 17
6	2'-6" x 6'-8"	INTERIOR	SWING	SOLID CORE	RH	1	1, 6, 12
7	2'-6" x 6'-8"	INTERIOR	SWING	SOLID CORE	LH	1	1, 6, 12
8	2'-8" x 6'-8"	INTERIOR	SWING	SOLID CORE	LH	2	1, 12, 15
9	2'-8" x 6'-8"	INTERIOR	SWING	SOLID CORE	RH	1	1, 12, 15
10	3'-0" x 6'-8"	INTERIOR	SWING	SOLID CORE	LH	1	1, 12, 15
11	3'-0" x 6'-8"	INTERIOR	SWING	SOLID CORE	RH	2	1, 12, 15
12	3'-0" x 6'-8"	INTERIOR	POCKET	SOLID CORE	-	1	1, 3, 12
13	3'-0" x 7'-0"	EXTERIOR	SWING	INSULATED FIBERGLASS	RH	1	1, 2, 4, 7, 9, 10, 11, 13
14	3'-0" x 7'-0"	EXTERIOR	SWING	INSULATED FIBERGLASS	LH	1	1, 2, 7, 9, 10, 11, 13
15	3'-0" x 7'-0"	EXTERIOR	SWING	INSULATED FIBERGLASS	RH	1	1, 2, 5, 7, 9, 10, 11, 13
16	9'-0" x 8'-0"	EXTERIOR	OVERHEAD	INSULATED STEEL	-	2	1, 2, 5, 10, 13
17	(2) 4'-6" x 8'-0"	EXTERIOR	DOUBLE SWING	INSULATED WOOD	-	1	1, 2, 5, 7, 10, 11, 13
18	6'-0" x 6'-8"	EXTERIOR	1 FIXED / 1 SWING	INSULATED FIBERGLASS	LH	1	1, 2, 7, 10, 11, 13
19	3'-0" x 6'-8"	SCREEN PORCH	SWING	FIBERGLASS	RH	1	1, 7, 8, 14

- NOTES:
1. SEE SPECIFICATIONS FOR DOOR MANUFACTURER, DOOR TYPE AND DOOR AND GLAZING PERFORMANCE SPECIFICATIONS.
  2. LITES IN DOORS, SIDELITES AND FIXED PANELS TO BE TEMPERED.
  3. POCKET DOOR IN ITS OPEN POSITION TO HAVE 32" CLEAR OPENING WITH PUSH/PULL HANDLE EXPOSED AND POCKET DOOR LOCK.
  4. FRONT ENTRY DOOR TO HAVE 12" SIDELITES ON EACH SIDE WHICH ARE FRAMED SEPARATELY FROM THE DOOR.
  5. DOOR IN GARAGE.
  6. BATHROOM DOOR TO HAVE PRIVACY LOCK.
  7. THRESHOLD TO BE BEVELED WITH SLOPE NOT TO EXCEED 1:2 AND HEIGHT NOT TO EXCEED 1/4".
  8. SCREEN PORCH DOOR TO BE FIBERGLASS FRAME WITH SCREEN INSERTS.
  9. SIMULATED DIVIDED LITES IN DOORS, SIDELITES AND FIXED PANELS.
  10. DOOR TO HAVE WEATHERSTRIPPING.
  11. EXTERIOR DOOR TO HAVE KEYED ENTRANCE LOCK.
  12. INTERIOR DOOR PAINTED P-11.
  13. EXTERIOR DOOR PAINTED P-14 (EXTERIOR), P-11 (INTERIOR).
  14. SCREEN PORCH DOOR PAINTED P-13.
  15. BEDROOM DOOR TO HAVE PASSAGE LOCK.
  16. CLOSET DOOR TO HAVE DUMMY HARDWARE.
  17. POCKET DOOR TO HAVE POCKET DOOR LOCK.

\*\* SEE 4/A-504 FOR EXTERIOR DOOR INSTALLATION SEQUENCE.

\*\*\* ALL TROPICAL WOOD, IF USED, MUST BE FSC-CERTIFIED.

## 2 WINDOW TYPES

SCALE: 3/8" = 1'-0"

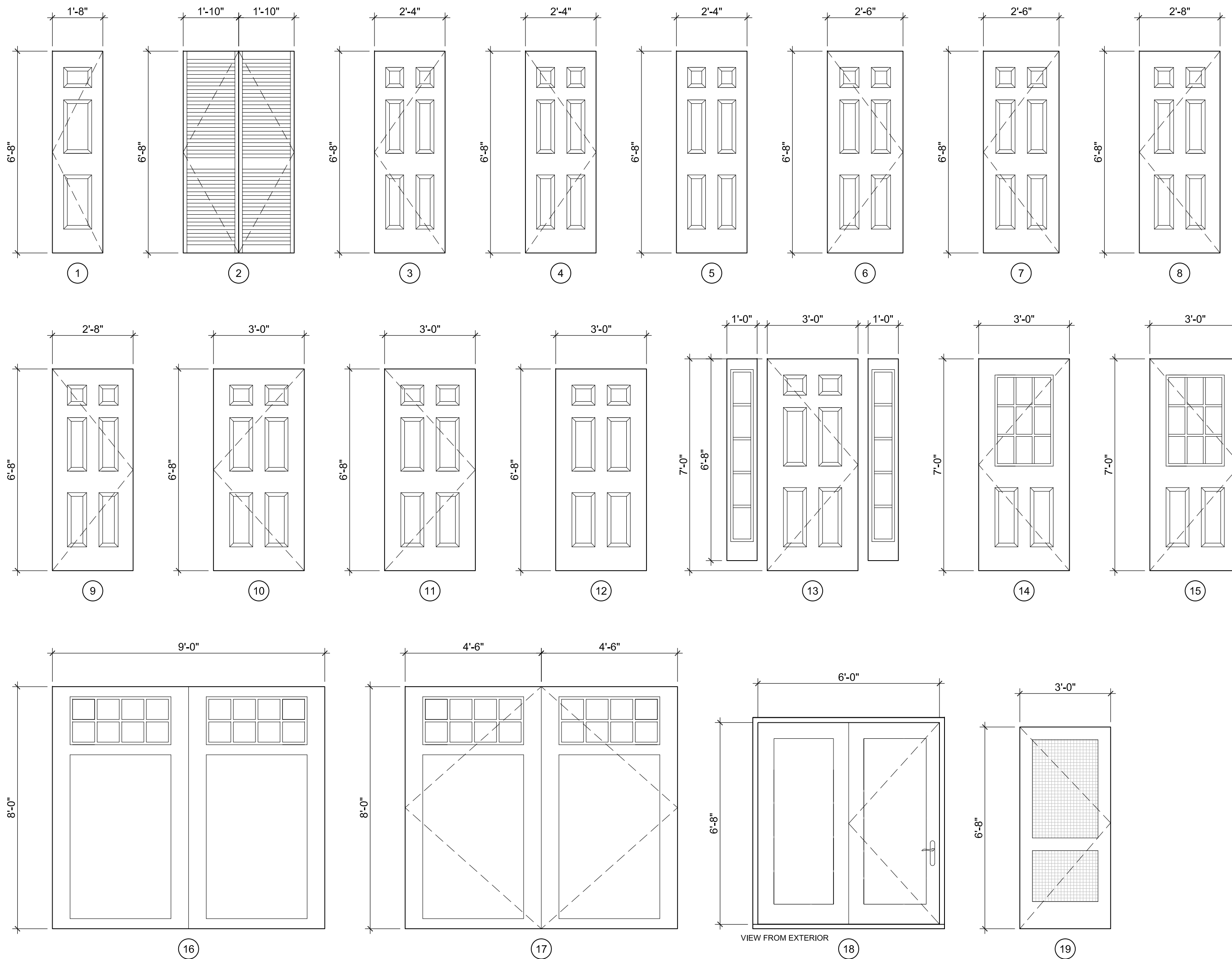

## 1 DOOR TYPES

SCALE: 3/8" = 1'-0"



30 FOREST STREET SOMERVILLE, MA  
 T: (978) 589-5100 F: (978) 589-5103  
 www.buildingscience.com

CONSULTANT:

PROJECT:

National Institute of Standards and Technology

**NET ZERO ENERGY RESIDENTIAL TEST FACILITY**

NIST Campus  
 Gaithersburg, MD



U.S. DEPARTMENT OF ENERGY | Energy Efficiency & Renewable Energy

MARK	DATE	DESCRIPTION
ISSUE:	03/31/10	ISSUED FOR CONSTRUCTION

PROJECT NO: NIST NZERTF  
 CAD DWG FILE: A-PLOT-SCHD-NZERTF  
 DRAWN BY: CG  
 CHECKED BY: BP

COPYRIGHT © 2009  
 BUILDING SCIENCE CORPORATION

SHEET TITLE:

**WINDOW & DOOR SCHEDULES & TYPES**

SCALE AS NOTED

**A-601**





CONSULTANT:

PROJECT:

National Institute of Standards and Technology

**NET ZERO ENERGY RESIDENTIAL TEST FACILITY**

NIST Campus  
Gaithersburg, MD



U.S. DEPARTMENT OF ENERGY | Energy Efficiency & Renewable Energy

MARK	DATE	DESCRIPTION
ISSUE:	03/31/10	ISSUED FOR CONSTRUCTION

PROJECT NO: NIST NZERTF  
CAD DWG FILE: A-PLOT-SCHD-NZERTF  
DRAWN BY: HW  
CHECKED BY: BP

COPYRIGHT © 2009  
BUILDING SCIENCE CORPORATION  
SHEET TITLE:

**INTERIOR FINISH SCHEDULE**

SCALE AS NOTED

**A-602**

INTERIOR FINISH SCHEDULE									
	ROOM NAME	FLOOR	BASE	CROWN	WALLS		CEILING		NOTES
					MATL	COLOR	MATL	COLOR	
BASEMENT	BASEMENT	CONC	-	-	GWB	P-1	-	-	
	STAIR	WF-1	-	-	GWB	P-1	GWB	P-10	
FIRST FLOOR	GARAGE	CONC	-	-	GWB	P-1	GWB	P-10	
	MUDROOM	CT-1	WB-1	CM-1	GWB	P-1	GWB	P-10	
	COAT CLOSET	CT-1	WB-1	-	GWB	P-1	GWB	P-10	
	BATH #1	CT-1	WB-3	CM-1	GWB/CT-4	P-7	GWB	P-10	CT-3A SHOWER FLR.
	UTILITY CLOSET	WF-1	WB-1	-	GWB	P-1	GWB	P-10	
	W/D CLOSET	WF-1	WB-1	-	GWB	P-1	GWB	P-10	
	KITCHEN	WF-1	WB-1/WB-2	CM-1	GWB/CT-5	P-3	GWB	P-10	C-1
	DINING ROOM	WF-1	WB-1/WB-2	CM-1	GWB	P-3	GWB	P-10	
	SCREEN PORCH	CONC	TRIM W/CAF	3" EXT.	BEAD BD	P-13	BEAD BD	P-15	EXT. PVC PRODUCTS
	LIVING ROOM	WF-1	WB-1/WB-2	CM-1	GWB	P-4	GWB	P-10	
	ENTRY HALL	WF-1	WB-1/WB-2	CM-1	GWB	P-1	GWB	P-10	
SECOND FLOOR	OFFICE/OPT. BR. 4	WF-1	WB-1	CM-1	GWB	P-4	GWB	P-10	
	OFFICE CLOSET	WF-1	WB-1	-	GWB	P-1	GWB	P-10	
	STAIR	WF-1	WB-1	-	-	-	-	-	
	HALL	WF-1	WB-1	CM-1	GWB	P-1	GWB	P-10	
	HALL CLOSET	WF-1	WB-1	-	GWB	P-1	GWB	P-10	
	LINEN CLOSET	WF-1	WB-1	-	GWB	P-1	GWB	P-10	
	BEDROOM 2	WF-1	WB-1	CM-1	GWB	P-5	GWB	P-10	
	BEDROOM 2 CLOSET	WF-1	WB-1	-	GWB	P-1	GWB	P-10	
	BEDROOM 3	WF-1	WB-1	CM-1	GWB	P-6	GWB	P-10	
	BEDROOM 3 CLOSET	WF-1	WB-1	-	GWB	P-1	GWB	P-10	
	BATH #2	CT-2	WB-1	-	GWB/CT-6	P-2	GWB	P-10	C-2
MASTER BEDROOM	WF-1	WB-1	CM-1	GWB	P-8	GWB	P-10		
MASTER BATH	CT-3	WB-1	CM-1	GWB/CT-7	P-9	GWB	P-10	C-3, CT-3A SHWR FLR.	
MASTER CLOSET	WF-1	WB-1	-	GWB	P-1	GWB	P-10		
MASTER CLOSET	WF-1	WB-1	-	GWB	P-1	GWB	P-10		

FINISH SCHEDULE KEY			
MARK	DESCRIPTION	MARK	DESCRIPTION
GWB	GYPSUM WALL BOARD	P-7	WALL PAINT COLOR
CONC	CONCRETE	P-8	WALL PAINT COLOR
CT-1	CERAMIC TILE 1	P-9	WALL PAINT COLOR
CT-2	CERAMIC TILE 2	P-10	CEILING PAINT COLOR
CT-3	CERAMIC TILE 3	P-11	INTERIOR TRIM PAINT COLOR
CT-3A	CERAMIC TILE 3A	P-12	SIDING PAINT COLOR
CT-4	CERAMIC TILE 4	P-13	EXTERIOR TRIM PAINT COLOR
CT-5	CERAMIC TILE 5	P-14	EXTERIOR DOOR PAINT COLOR
CT-6	CERAMIC TILE 6	P-15	CEILING PAINT COLOR
CT-7	CERAMIC TILE 7	WB-1	WOOD BASE 1
WF-1	WOOD FLOOR 1 - CLEAR FINISH	WB-2	WOOD BASE 2
P-1	WALL PAINT COLOR	WB-3	WOOD BASE 3
P-2	WALL PAINT COLOR	CM-1	CROWN MOULDING 1
P-3	WALL PAINT COLOR	C-1	COUNTERTOP 1
P-4	WALL PAINT COLOR	C-2	COUNTERTOP 2
P-5	WALL PAINT COLOR	C-3	COUNTERTOP 3
P-6	WALL PAINT COLOR		

- NOTES:  
1. SEE SPECIFICATIONS FOR PRODUCT INFORMATION.  
2. SEE INTERIOR ELEVATIONS FOR BACKSPASH EXTENT.

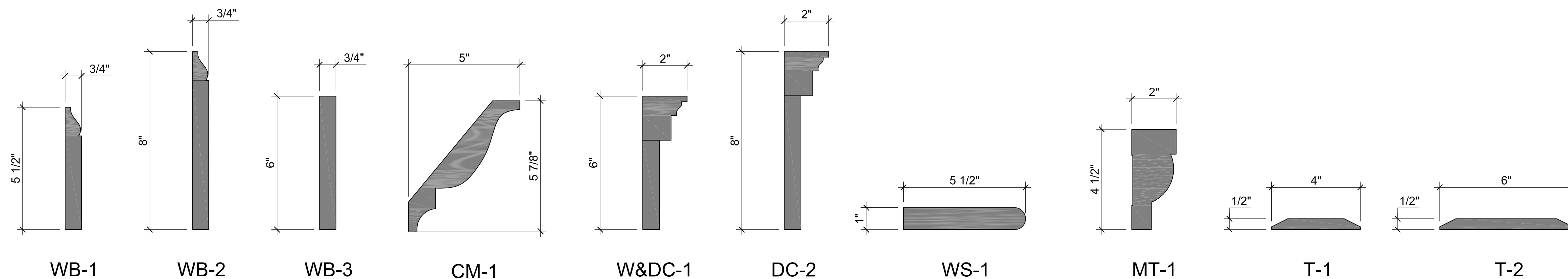

**1 BASE & CROWN MOULDING, WINDOW & DOOR CROWNS, WINDOW STOOL, MANTLE TRIM AND THRESHOLD PROFILES**  
SCALE: 3" = 1'-0"



30 FOREST STREET SOMERVILLE, MA  
T: (978) 589-5100 F: (978) 589-5103  
www.buildingscience.com

CONSULTANT:

PROJECT:

National Institute of Standards and Technology

**NET ZERO ENERGY  
RESIDENTIAL TEST  
FACILITY**

NIST Campus  
Gaithersburg, MD



U.S. DEPARTMENT OF ENERGY | Energy Efficiency & Renewable Energy

MARK	DATE	DESCRIPTION
	07/27/10	UPDATED
	06/29/10	UPDATED
ISSUE:	03/31/10	ISSUED FOR CONSTRUCTION

PROJECT NO: NIST NZERTF  
CAD DWG FILE: A-PLOT-SCHD-NZERTF  
DRAWN BY: CG  
CHECKED BY: BP

COPYRIGHT © 2009  
BUILDING SCIENCE CORPORATION

SHEET TITLE:

**PENETRATION  
SCHEDULE**

SCALE AS NOTED



**A-603**

PENETRATION SCHEDULE						
	MARK	TYPE	LOCATION	QTY.	SHEET REFERENCE	NOTES
SLAB	S1	SOIL GAS VENT	BASEMENT SLAB	1	A-102, P-101	
	S2	FLOOR DRAIN	BASEMENT SLAB	2	A-102, P-101	
	S3	STEEL PIPE COLUMN	BASEMENT SLAB	2	A-102	
	S4	SUMP PUMP	BASEMENT SLAB	1	A-102, P-101	
	S5	SEWER CONNECTION	BASEMENT SLAB	1	A-102, P-101	
	S6	CONDENSATE DRAIN	BASEMENT SLAB	6	A-102, P-101	
FOUNDATION WALL	F1	VERT. GROUND LOOP SYSTEM	FOUNDATION WALL	1	A-102, M-101	2
	F2	SLINKY LOOP SYSTEM	FOUNDATION WALL	1	A-102, M-101	2
	F3	HORZ. GROUND LOOP SYSTEM	FOUNDATION WALL	1	A-102, M-101	2
	F4	SUMP PUMP OUTLET	FOUNDATION STEM WALL	1	A-102, A-201	
	F5	INSTRUMENTATION CONDUIT	FOUNDATION WALL	2	A-102, E-103	1,7
	F6	GAS CONNECTION	FOUNDATION WALL	1	A-102, P-101	
	F7	WATER CONNECTION	FOUNDATION WALL	1	A-102, F-101, P-101	8
	F8	ELECTRICITY CONNECTION	FOUNDATION WALL	2	A-102, E-103	
	F9	AIR-TO-AIR OUTDR. UNIT CONDUIT	FOUNDATION STEM WALL	1	A-102, A-201, M-102	1, 4
	F10	AIR-TO-AIR OUTDR UNIT CONDUIT	FOUNDATION WALL	1	A-102, A-201	3,5,13
	F11	COMMUNICATION/FIRE SAFETY	FOUNDATION WALL	1	A-102, E-101	9
	F12	INVERTER UTILITY CUTOFF	FOUNDATION WALL	1	A-102, E-101	10
	F13	FIRE DEPARTMENT CONNECTION	FOUNDATION WALL	1	A-102, F-101	11
EXTERIOR WALL	E1	COLLECTOR PANEL CONDUIT	SECOND FLOOR RIM JOIST	2	A-201	6
	E2	EXTERIOR LANTERN	EXTERIOR WALL	4	A-201, A-202	1
	E3	WEATHER PROTECTED OUTLET	EXTERIOR WALL	8	A-201, A-202	1
	E4	CONDUIT FOR GAS FURNACE	EXTERIOR WALL	1	A-201	3
	E5	DRYER VENT	SECOND FLOOR RIM JOIST	1	A-202, M-102	
	E6	RANGE HOOD VENT	SECOND FLOOR RIM JOIST	1	A-202, M-102	
	E7	HRV EXHAUST	SECOND FLOOR RIM JOIST	1	A-202, M-102	
	E8	HRV INLET	SECOND FLOOR RIM JOIST	1	A-202, M-102	
	E9	INSTRUMENTATION CONDUIT	SECOND FLOOR RIM JOIST	1	A-202, E-103	1,12
	E10	CONDUIT FOR GAS WTR. HEATER	EXTERIOR WALL	1	A-202	3
	E11	MULTISPLIT OUTDR. UNIT CONDUIT	EXTERIOR WALL	2	A-201, M-102	5
	E12	HOSE BIBB	EXTERIOR WALL	1	A-202, P-102	
ROOF	R1	PLUMBING STACK VENT	NORTH FACING ROOF	1	A-113, A-202, P-104	
	R2	SOIL GAS VENT	NORTH FACING ROOF	1	A-113, A-202, P-104	
	R3	PV ARRAY CONDUIT	SOUTH FACING ROOF	3	A-113, E-501	

NOTES:

1. QUANTITY INDICATED FOR HOUSE ONLY (NOT GARAGE).
2. CONSISTS OF 3 CONDUITS: (1) 2" HPWS PIPE, (1) 2" HPWR PIPE AND (1) 1-1/2" PVC WIRE CONDUIT.
3. CONDUIT PROVIDED FOR EQUIPMENT TO BE INSTALLED IN THE FUTURE
4. CONSISTS OF 4 CONDUITS: (3) 2" CONDUITS FOR REFRIGERANT LINES AND (1) 1-1/2" PVC WIRE CONDUIT.
5. CONSISTS OF 3 CONDUITS: (2) 2" CONDUITS FOR REFRIGERANT LINES AND (1) 1-1/2" PVC WIRE CONDUIT.
6. CONDUIT TO INCLUDE BOTH SUPPLY AND RETURN LINES
7. 4" PVC CONDUIT
8. 3" COMBINATION DOMESTIC/SPRINKLER
9. CONSISTS OF (4) 1-1/2" CONDUITS: 1) FIBER, 2) COPPER TELECOMMUNICATION CABLE, 3) VIDEO, 4) FIRE SYSTEM
10. CONSISTS OF (2) CONDUITS: ONE FOR INPUT, ONE FOR OUTPUT
11. 2-1/2" CONNECTION TO FREE-STANDING FIRE DEPARTMENT CONNECTION
12. 3" PVC CONDUIT
13. ADD 1 TO QUANTITY IF THE HIGH VELOCITY HVAC OPTION IS AWARDED



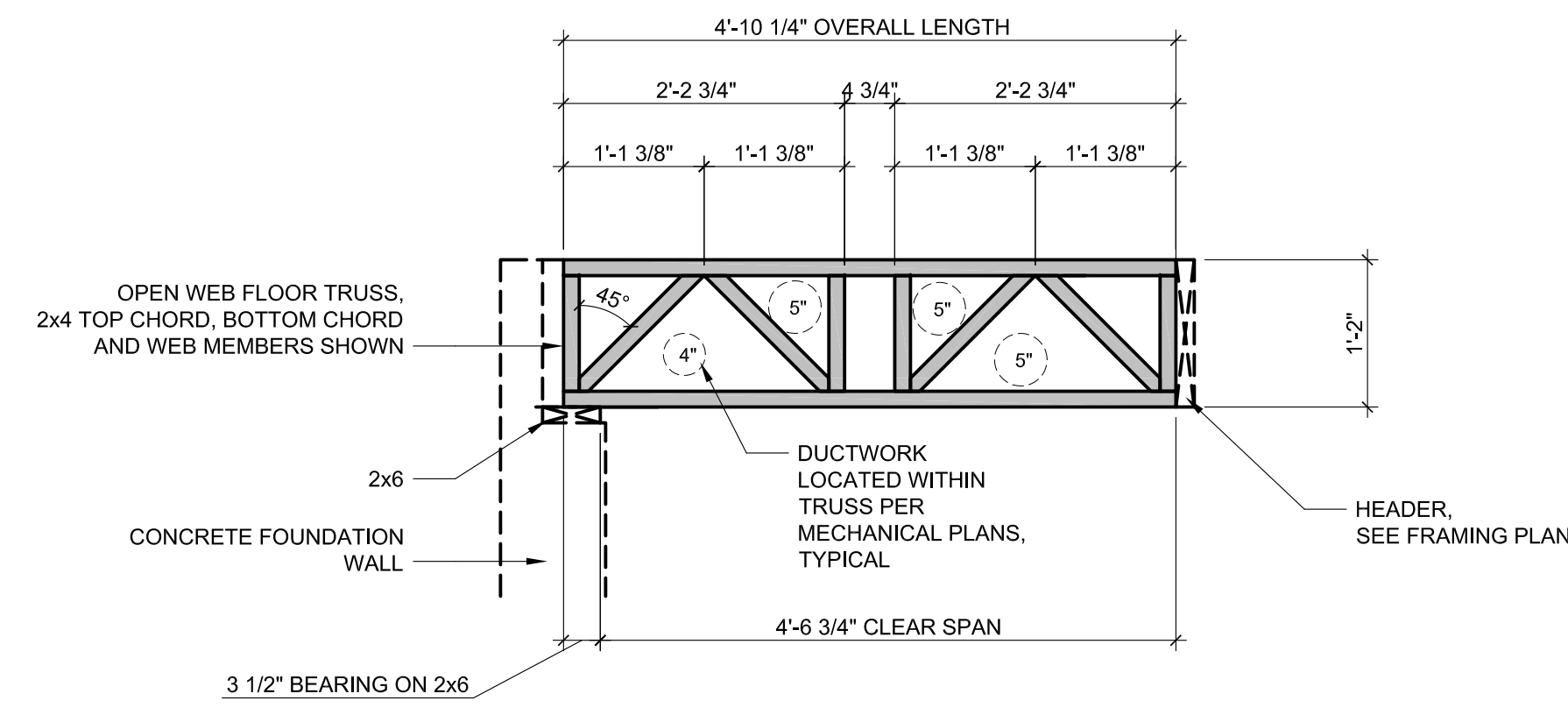

4 14" DEEP OPEN WEB FLOOR TRUSS - TYPE "D" ELEVATION  
SCALE: 3/4" = 1'-0"

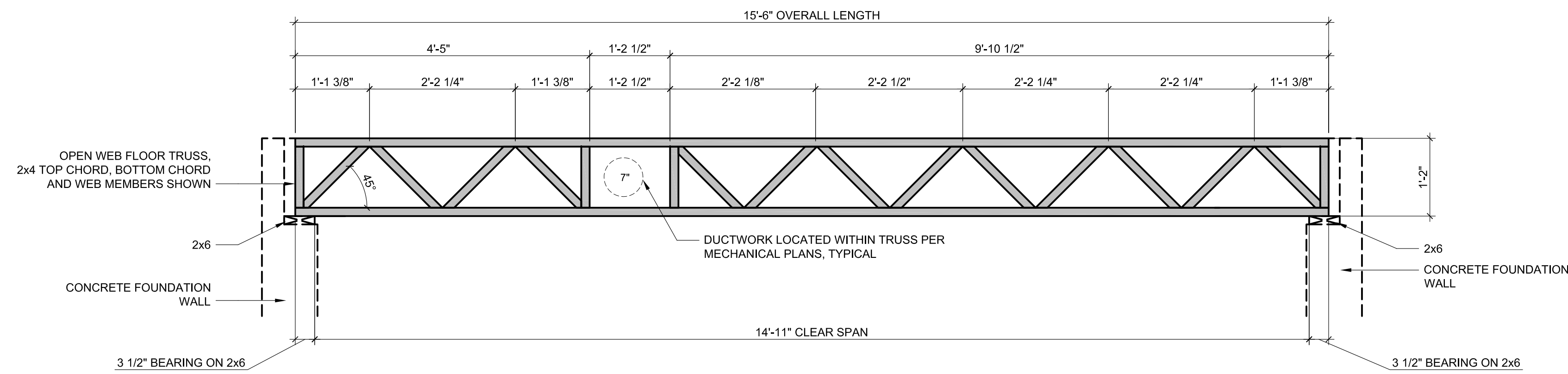

3 14" DEEP OPEN WEB FLOOR TRUSS - TYPE "C" ELEVATION  
SCALE: 3/4" = 1'-0"

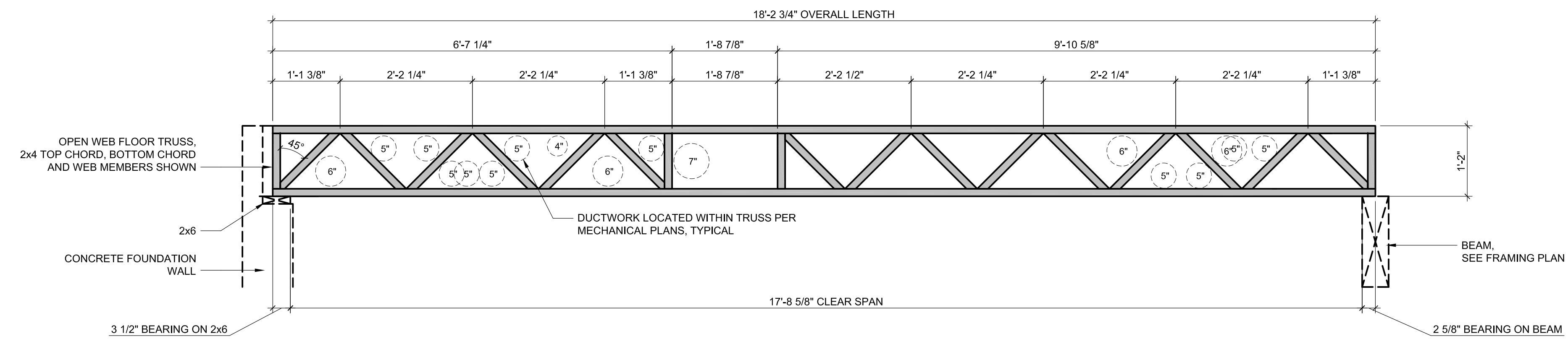

2 14" DEEP OPEN WEB FLOOR TRUSS - TYPE "B" ELEVATION  
SCALE: 3/4" = 1'-0"

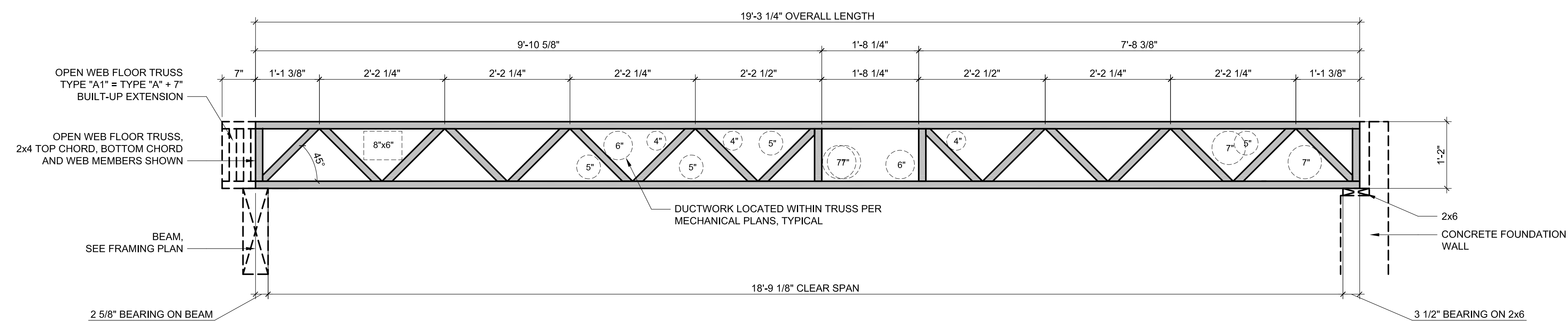

1 14" DEEP OPEN WEB FLOOR TRUSS - TYPE "A" AND "A1" ELEVATION  
SCALE: 3/4" = 1'-0"

GENERAL SHEET NOTES

1. OPEN WEB FLOOR TRUSSES SHOWN FOR DESIGN INTENT AND COORDINATION WITH DUCT LAYOUTS ONLY.
2. SEE M-101a AND M-104a FOR FLOOR FRAMING AND DUCT LAYOUT PLANS.
3. SEE A-104 AND A-108 FOR FRAMING PLANS AND OPEN WEB FLOOR TRUSS TYPE DESIGNATIONS.

BUILDING SCIENCE CORPORATION

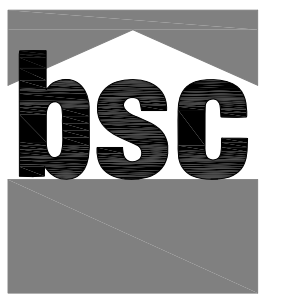

30 FOREST STREET SOMERVILLE, MA  
T: (978) 589-5100 F: (978) 589-5103  
www.buildingscience.com

CONSULTANT:

PROJECT:

National Institute of Standards and Technology

NET ZERO ENERGY RESIDENTIAL TEST FACILITY

NIST Campus Gaithersburg, MD



U.S. DEPARTMENT OF ENERGY Energy Efficiency & Renewable Energy

MARK	DATE	DESCRIPTION
ISSUE:	03/31/10	ISSUED FOR CONSTRUCTION

PROJECT NO: NIST NZERTF  
CAD DWG FILE: A-PLOT-SCHD-NZERTF  
DRAWN BY: KG  
CHECKED BY: BP

COPYRIGHT © 2009 BUILDING SCIENCE CORPORATION

SHEET TITLE:

FIRST FLOOR OPEN WEB FLOOR TRUSS TYPE ELEVATIONS

SCALE AS NOTED

A-701

GENERAL SHEET NOTES

1. OPEN WEB FLOOR TRUSSES SHOWN FOR DESIGN INTENT AND COORDINATION WITH DUCT LAYOUTS ONLY.
2. SEE M-101a AND M-104a FOR FLOOR FRAMING AND DUCT LAYOUT PLANS.
3. SEE A-104 AND A-108 FOR FRAMING PLANS AND OPEN WEB FLOOR TRUSS TYPE DESIGNATIONS.

BUILDING SCIENCE CORPORATION



30 FOREST STREET SOMERVILLE, MA  
 T: (978) 589-5100 F: (978) 589-5103  
 www.buildingscience.com

CONSULTANT:

PROJECT:

National Institute of Standards and Technology

NET ZERO ENERGY RESIDENTIAL TEST FACILITY

NIST Campus Gaithersburg, MD



U.S. DEPARTMENT OF ENERGY | Energy Efficiency & Renewable Energy

MARK	DATE	DESCRIPTION
ISSUE:	03/31/10	ISSUED FOR CONSTRUCTION

PROJECT NO: NIST NZERTF  
 CAD DWG FILE: A-PLOT-SCHD-NZERTF  
 DRAWN BY: KG  
 CHECKED BY: BP

COPYRIGHT © 2009 BUILDING SCIENCE CORPORATION

SHEET TITLE:

SECOND FLOOR OPEN WEB FLOOR TRUSS TYPE ELEVATIONS

SCALE AS NOTED

A-702

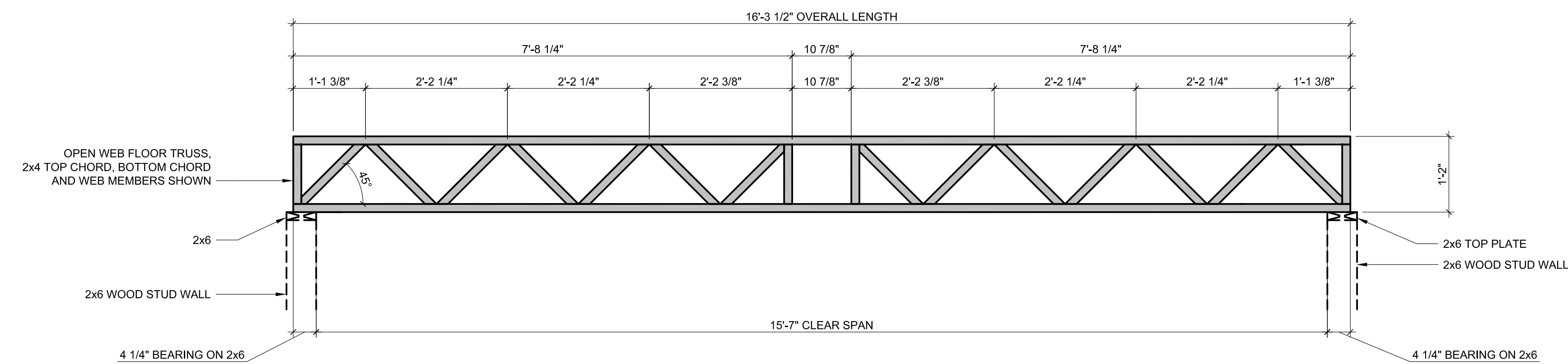

3 14" DEEP OPEN WEB FLOOR TRUSS - TYPE "G" ELEVATION

SCALE: 3/4" = 1'-0"

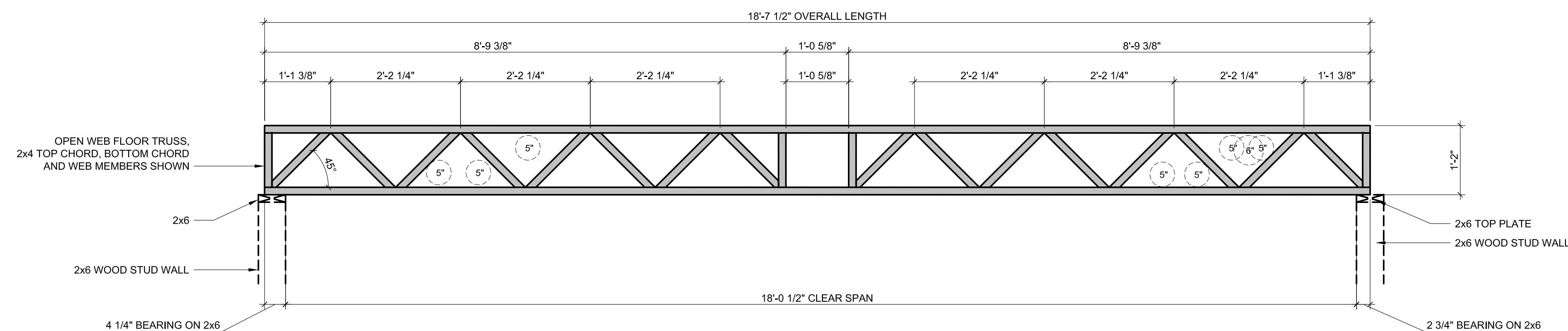

2 14" DEEP OPEN WEB FLOOR TRUSS - TYPE "F" ELEVATION

SCALE: 3/4" = 1'-0"

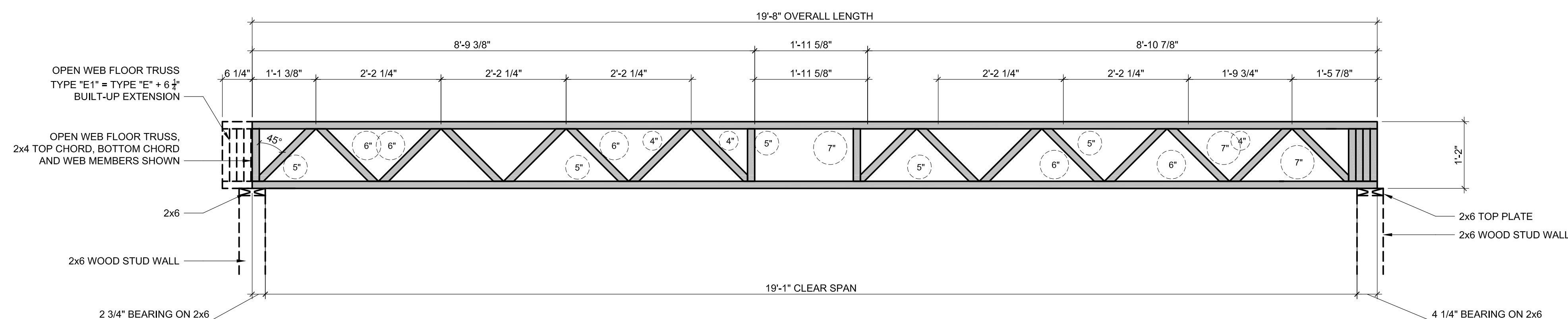

1 14" DEEP OPEN WEB FLOOR TRUSS - TYPE "E" AND E1" ELEVATION

SCALE: 3/4" = 1'-0"