

**Federal Building and Fire Safety Investigation
of the World Trade Center Disaster**

**National Construction Safety Team
Advisory Committee Meeting**

**Project 6 – Structural Fire Response and
Collapse Analysis**

October 19, 2004

John L. Gross, PhD, P.E.
Therese P. McAllister, PhD, P.E.

**Building and Fire Research Laboratory
National Institute of Standards and Technology
U.S. Department of Commerce**

Project 6 Staff

NIST

John Gross

Therese McAllister

Monica Starnes

Long Phan

Expert Contractors

Eduardo Kausel

Teng & Associates

Daniele Veneziano

Kaspar Willam

Simpson Gumpertz Heger, Inc., Contractor

Mehdi Zarghamee

Glen Bell

Atis Liepens

Frank Kan

Ron Hamburger

Said Bolourchi

Pedro Sifre

Computer Aided Engineering Associates, Subcontractor

Peter Barrett

Michael Bak

Disclaimer

Certain commercial entities, equipment, products, or materials and non-commercial entities are identified in this presentation in order to describe a procedure or concept adequately or to trace the history of the procedures and practices used. Such identification is not intended to imply recommendation, endorsement, or implication that the entities, products, materials, or equipment are necessarily the best available for the purpose. Nor does such identification imply a finding of fault or negligence by the National Institute of Standards and Technology.

Objectives

To determine the structural response of the WTC Towers to aircraft impact and internal fires and to identify the most probable structural collapse mechanisms.

- ❑ Task 1: Components and Subsystems
- ❑ Task 2: Global Analysis with Impact Damage
- ❑ Task 3: Evaluation of Collapse Hypotheses
- ❑ Task 4: Global Analysis without Impact Damage

Probabilistic Approach to Evaluate Changes in Global Capacity

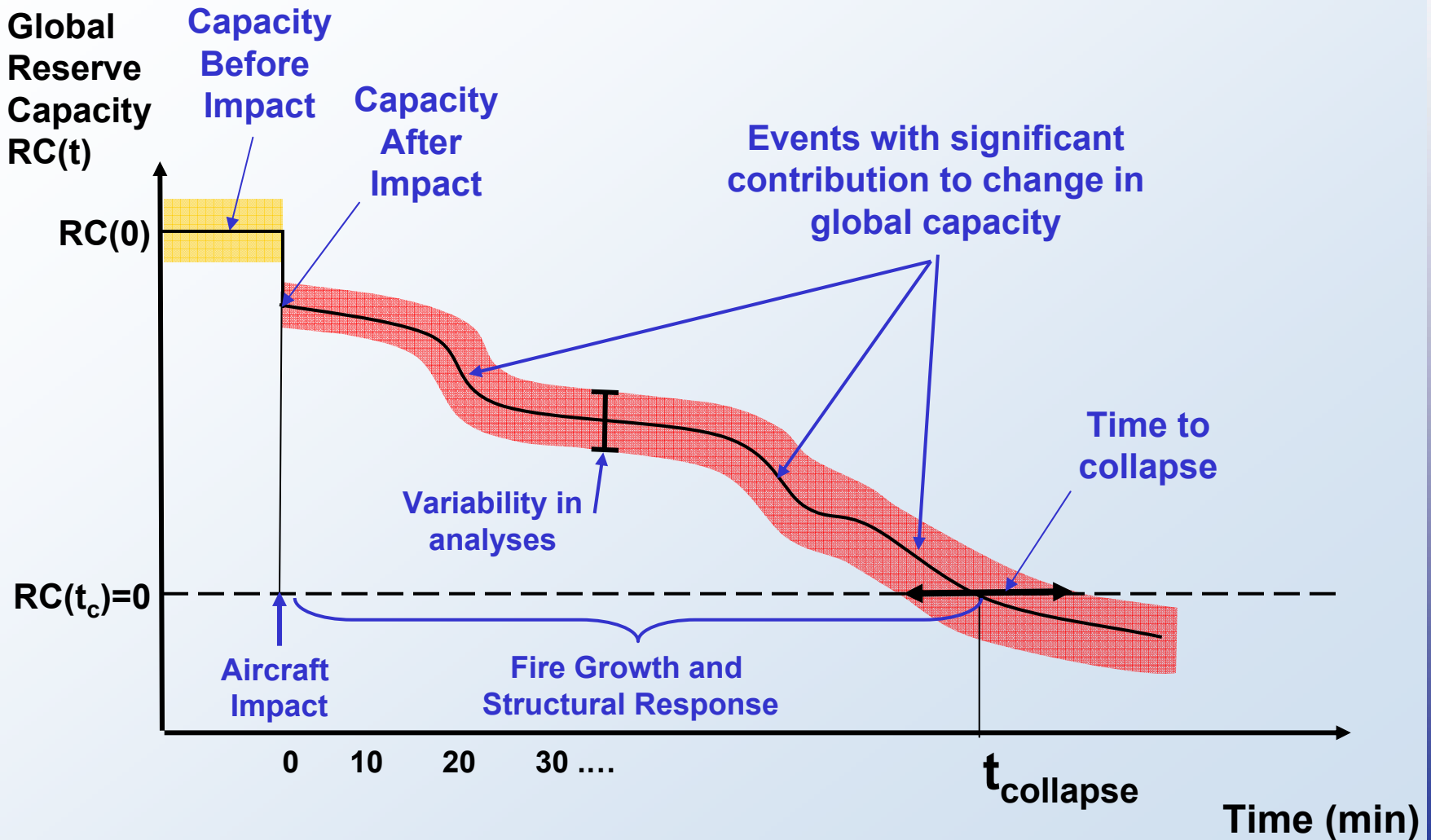

Analysis of Probable Collapse Sequence

NIST developed and used a comprehensive approach to determine the probable collapse sequences, from aircraft impact to collapse initiation. The approach:

- ❑ Combined mathematical modeling, well-established statistical and probability-based analysis methods, laboratory experiments, and analysis of photographic and videographic evidence.
- ❑ Allowed for evaluation and comparison of possible collapse sequences based on different damage states, fire paths, and structural load redistribution paths.
- ❑ Accounted for variations in models, input parameters, analyses, and observed events.

Critical Analysis Inter-Dependencies

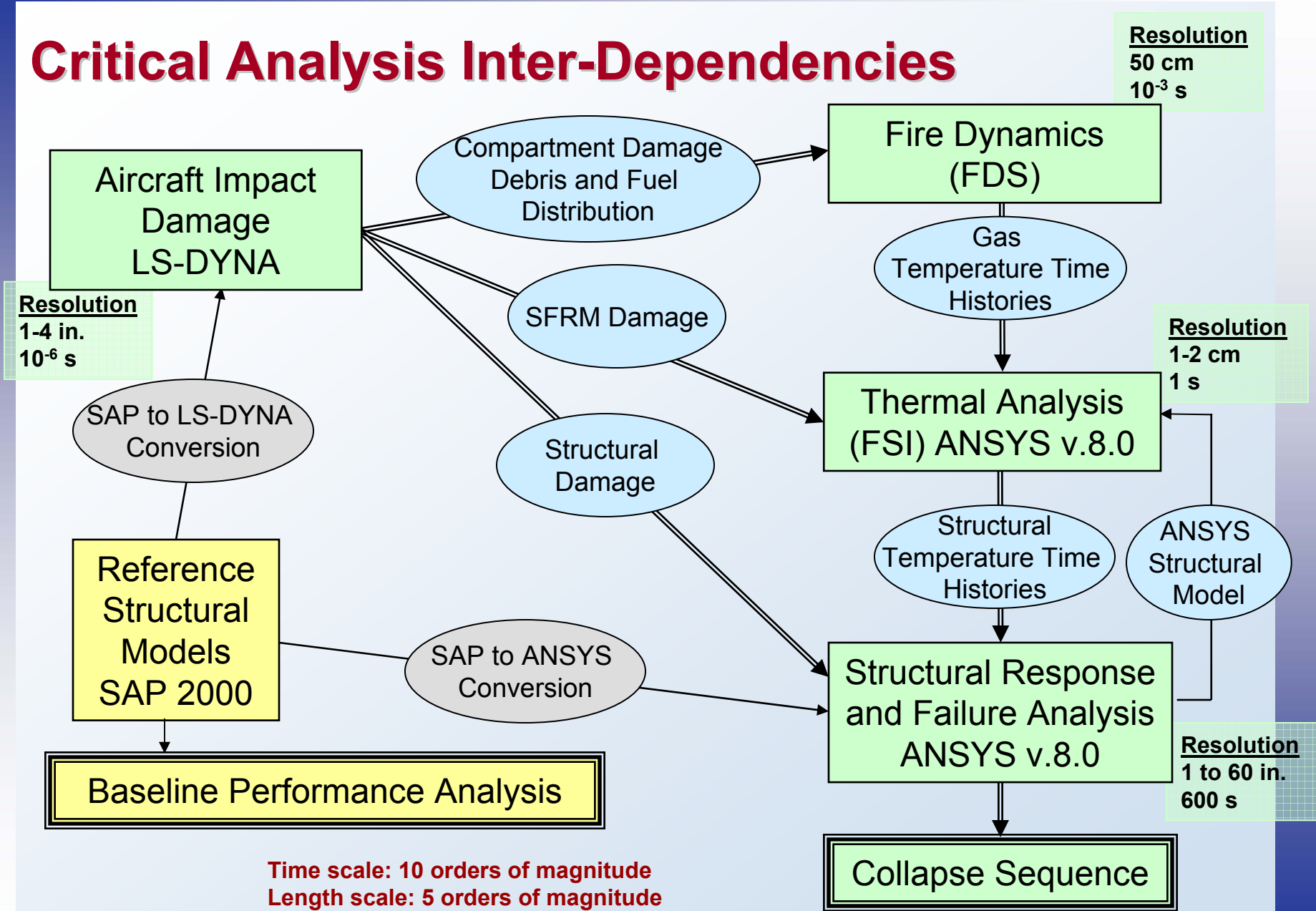

Observables from Photos, Videos, and Accounts

Aircraft Impact

- Impact damage to perimeter wall
- Engine exit location and speed
- Exit areas for debris
- Global stability after impact
- Aircraft impact conditions -velocity, location, orientation to building
- Stairwell damage

Fire/Thermal Analysis

- Fire in windows vs. location and time
- Smoke out windows vs. location and time
- Window breakage vs. location and time
- Metallurgical measurements of recovered steel

Structural Response

- Floors Draped in Windows
- Perimeter Column Bowing
- Rotation of Building above Impact Zone
- Time to Collapse

Inward Bowing of Perimeter Columns Some Minutes Prior to Collapse: WTC 1 South Face

©2001. New York City Police Department. All rights reserved.

10:22:59 a.m.

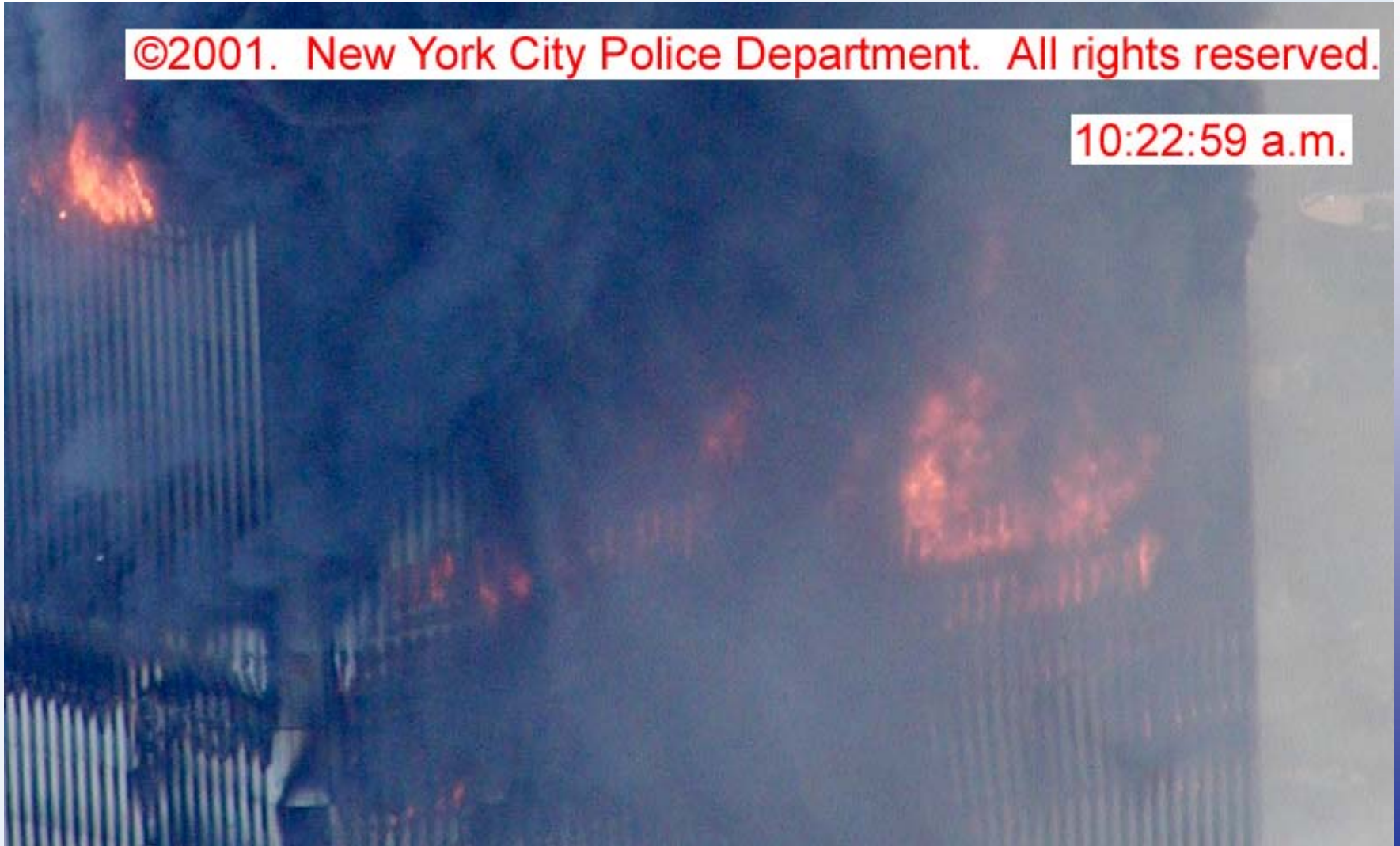

Inward Bowing of Perimeter Columns Some Minutes Prior to Collapse: WTC 2 East Face

9:58:55 a.m.

©2001. New York City Police Department. All rights reserved.

WTC 1 Collapse

Initiation of global collapse was first observed by the tilting of building sections above the impact regions of both WTC towers.

WTC 1 tilted to the south in this view from the northeast.



WTC 2 Collapse



WTC 2 tilted to the east and south and twisted in a counterclockwise motion in this view from the northeast.

Determining the Probable Collapse Sequence

- Conduct extensive sensitivity analyses to determine most influential factors for each analysis step.
- Determine three sets of most influential factors for each analysis step: realistic case, more severe case, less severe case.
- The set of most influential factors is highly correlated for the different analysis steps (i.e., they are not independent). For example, the more severe case of aircraft impact damage, results in the more severe case of fire dynamics, and they in turn lead to the more severe case of thermal analysis, and together they led to the more severe case of structural response analysis.
- The first analysis sequence considers the set of factors for the **realistic case** in each of the steps.
- A second analysis sequence is conducted to confirm the results for the realistic case.
 - If the results for the realistic case suggest the possibility of more damage due to impact and fire, the second analysis sequence considers the set of factors for the **more severe case** in each of the steps.
 - If the results for the realistic case suggest the possibility of less damage due to impact and fire, the second analysis sequence considers the set of factors for the **less severe case** in each of the steps.
- The analysis sequence is repeated with additional cases for the set of factors to determine the probable collapse sequence that best matches the observations.

Sensitivity Studies to Identify Influential Variables

Numerical experiments with an Orthogonal Factorial Design (OFD) method were conducted for detailed models of components and subsystems to identify parameters that strongly influenced the analysis results:

- ❑ Only parameters whose values were not known with certainty were selected; (parameters that were known with certainty were set to the known values).
- ❑ Selected parameters were varied within a range of likely values: Less Severe (-), Realistic (0), More Severe (+)
- ❑ OFD approach allowed for identification of influential parameters with a reduced number of analysis runs

Examples of OFD Experiments:

- ❑ Wing Component Without Fuel Impacting Exterior Panel - 13 parameters
- ❑ Engine Impact on Structural Subassembly - 11 parameters
- ❑ Fire Growth and Spread in Compartments - 5 parameters
- ❑ Thermal Insulation Thickness - 5 parameters
- ❑ Floor System and Perimeter Wall Failure Criteria – 3 parameters

Full Analysis Tree for Influential Parameter Effects

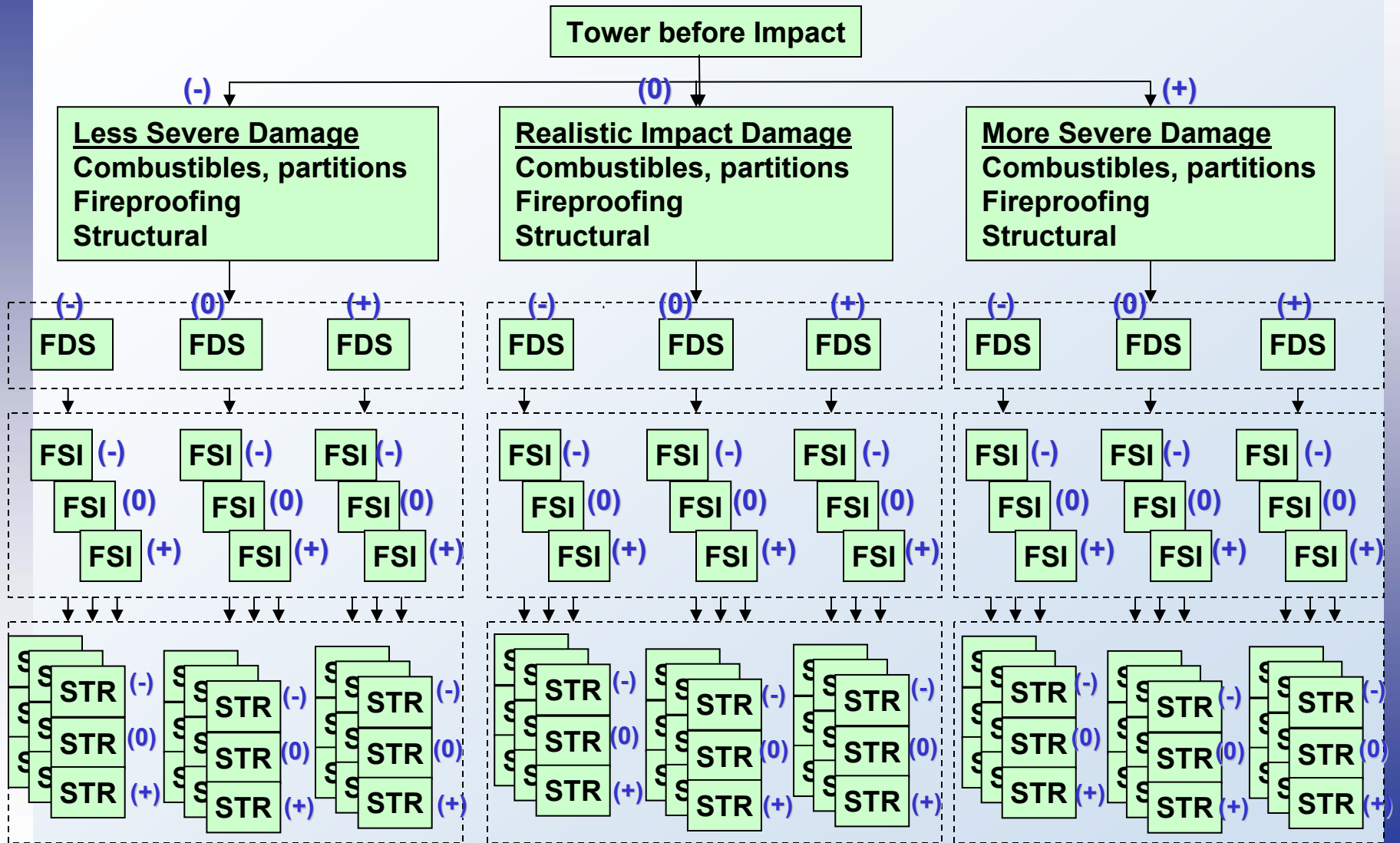

Influential Parameters Determined from Sensitivity Studies

Highly Correlated to Aircraft Damage

- ❑ Aircraft Impact
 - Aircraft Velocity and Location
 - Failure Criteria for High Strain Rates
 - Weights of Aircraft and Furnishings
- ❑ Fire Dynamics
 - Combustible Load
 - Core Ventilation
 - Rubble
- ❑ Thermal Analysis/FSI
 - SFRM damage

Independent of Aircraft Damage

- ❑ Structural Response to Temperature Dependent Material Properties
 - Yield Strength
 - Modulus of Elasticity
 - Ultimate Strength

Bounding Computational Analyses

Bounding computational analyses of subsystems and global systems, for specific response behaviors that were required to be captured in the final analyses, provided valuable insight into the collapse sequence.

These insights along with the sensitivity studies enabled significant reduction of the number of scenarios to be analyzed from the full analysis tree.

Pruned Analysis Tree for Influential Parameter Effects

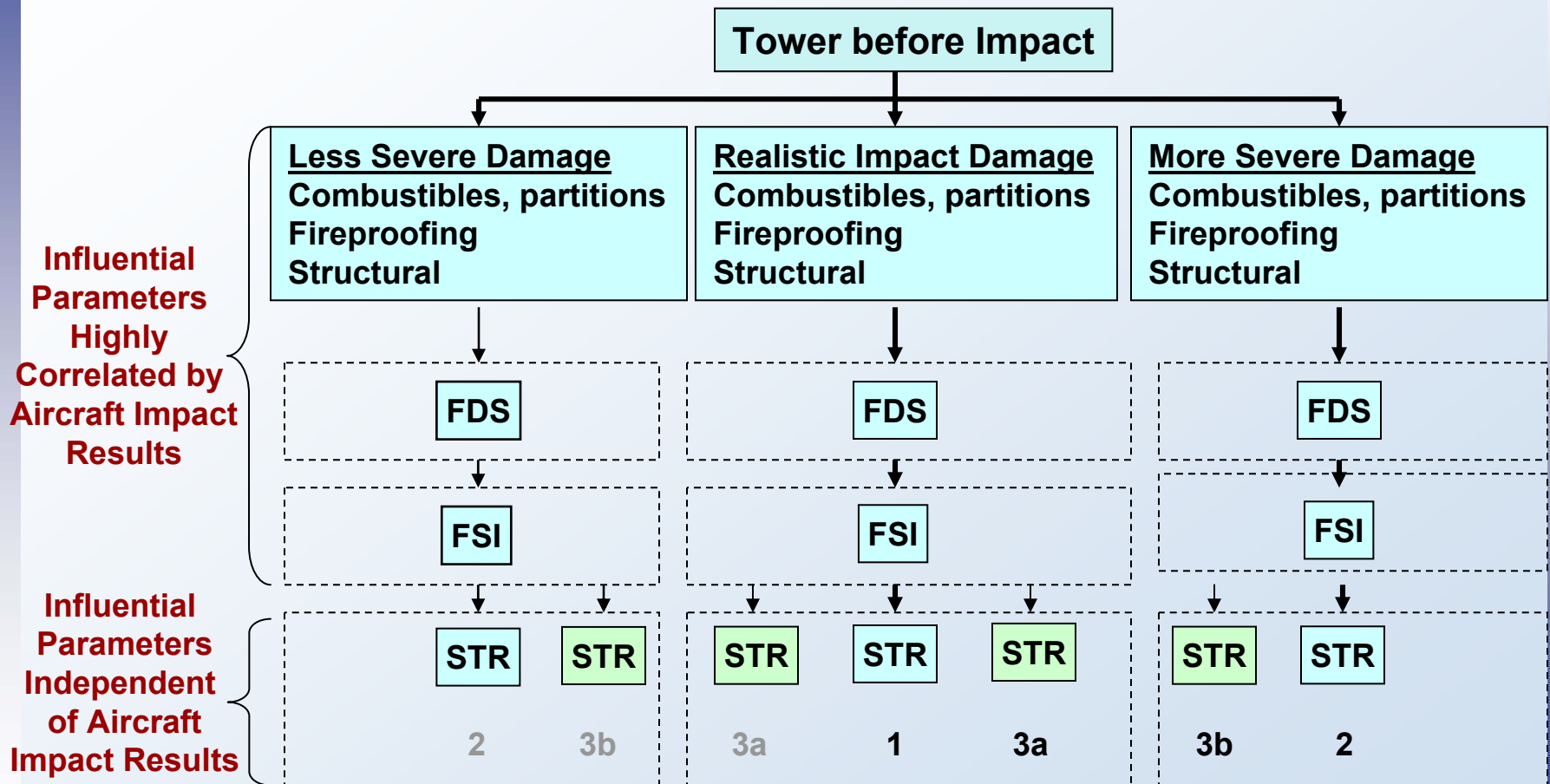

Leading Hypothesis for Collapse of WTC 1 (1)

The following chronological sequence of major events led to the eventual collapse of WTC 1; specific load redistribution paths and damage scenarios are being refined to determine the probable collapse sequence for WTC 1:

- ❑ Aircraft impact damage to perimeter columns, mainly on the North face, resulted in redistribution of column loads, mostly to the adjacent perimeter columns and to a lesser extent to the core columns.
- ❑ After breaching the building's perimeter, the aircraft continued to penetrate into the building, damaging floor framing, core columns, and fireproofing. Loads on the damaged columns were redistributed to other intact core and perimeter columns mostly via the floor systems and to a lesser extent via the hat truss.
- ❑ The subsequent fires, influenced by the impact damaged condition of the fireproofing:
 - Softened the core columns and caused them to shorten, resulting in a downward displacement of the core relative to the perimeter which led to the floors (1) pulling the perimeter columns inward, and (2) transferring vertical loads to the perimeter columns.
 - Softened the perimeter columns on the South face and also caused perimeter column loads to increase significantly due to restrained thermal expansion.

Leading Hypothesis for Collapse of WTC 1 (2)

- ❑ Due to the combined effects of heating on the core and perimeter columns, the South perimeter wall bowed inward and highly stressed sections buckled.
- ❑ The section of the building above the impact zone began tilting to the South as the bowed South perimeter columns buckled. The instability rapidly progressed horizontally across the entire South face and then across the adjacent East and West faces.
- ❑ The change in potential energy due to the downward movement of the building mass above the buckled columns exceeded the strain energy that could be absorbed by the structure. Global collapse then ensued.

Leading Hypothesis for Collapse of WTC 2 (1)

The following chronological sequence of major events led to the eventual collapse of WTC 2; specific load redistribution paths and damage scenarios are being refined to determine the probable collapse sequence for WTC 2:

- ❑ Aircraft impact damage to perimeter columns mainly on the South face, resulted in redistribution of column loads, mostly to the adjacent perimeter columns and to a lesser extent to the core columns.
- ❑ After breaching the building's perimeter, the aircraft continued to penetrate into the building, damaging floor framing, core columns, and fireproofing. Loads on the damaged columns were redistributed to other intact core and perimeter columns mostly via the floor systems and to a lesser extent via the hat truss.
- ❑ The subsequent fires, influenced by the impact damaged condition of the fireproofing :
 - Caused significant sagging of floors on the East side and induced the floors to pull the perimeter columns inward on the East face.
 - Softened the core columns on the East side and caused them to shorten, which transferred significant additional load to the perimeter columns on the East face primarily through the floor system and to a lesser extent through the hat truss.
 - Softened some of the perimeter columns that were exposed to high temperatures towards the northern half of the East face.

Leading Hypothesis for Collapse of WTC 2 (2)

- ❑ Due to the additional loads on the perimeter columns on the East face and the inward pulling of those columns, the East perimeter wall bowed inwards and highly stressed sections buckled.
- ❑ The section of the building above the impact zone began tilting to the East and South as both the East perimeter columns and the impact-damaged South perimeter columns buckled. The instability rapidly progressed horizontally across both faces and across the North face.
- ❑ The change in potential energy due to the downward movement of the building mass above the buckled columns exceeded the strain energy that could be absorbed by the structure. Global collapse then ensued.

Aircraft Impact Damage to WTC 1

Floor and Wall Damage

Fireproofing and Partitions



Floors



Column Damage

Severed



Heavy Damage



Moderate Damage



Realistic

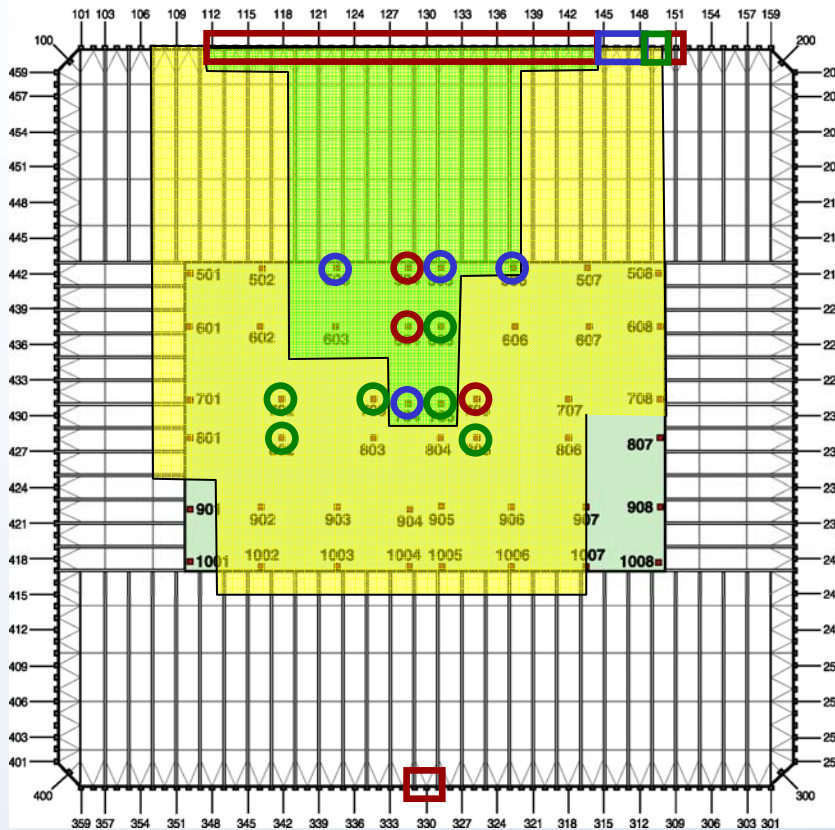

More Severe

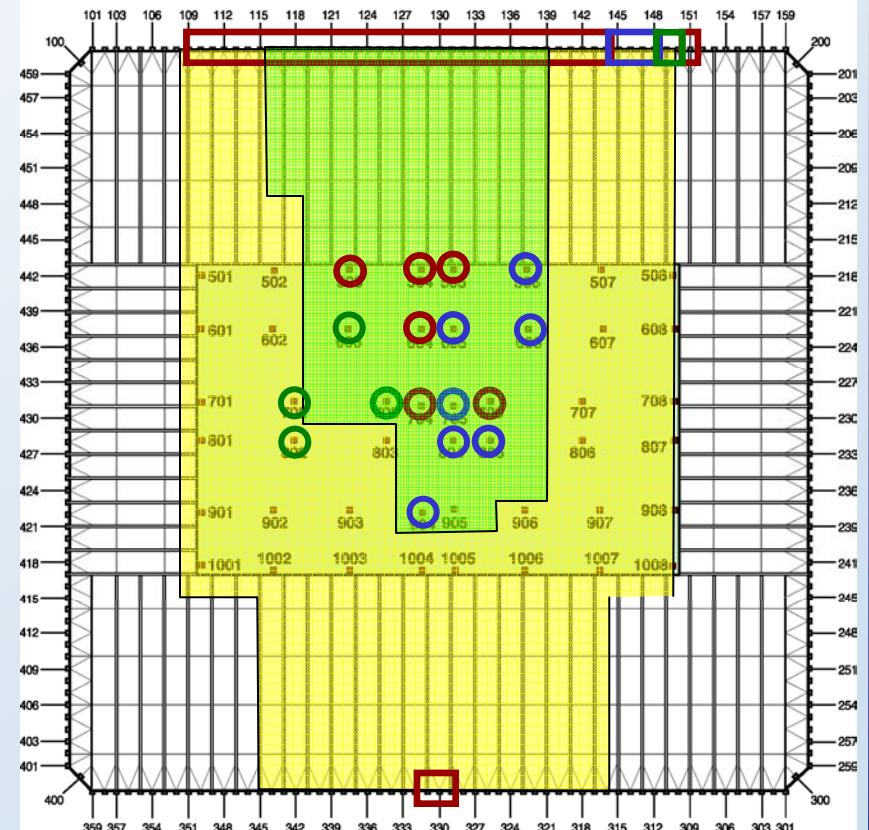

Aircraft Impact Damage to WTC 2

Floor and Wall Damage

Fireproofing and Partitions



Floors



Column Damage

Severed



Heavy Damage



Moderate Damage



Realistic

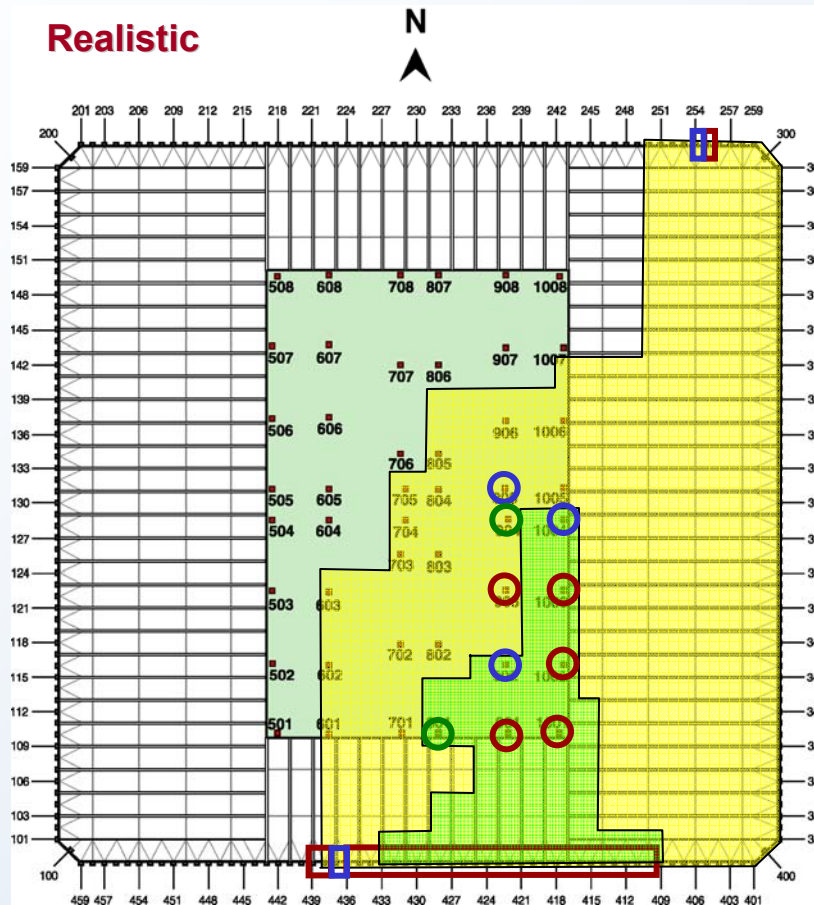

More Severe

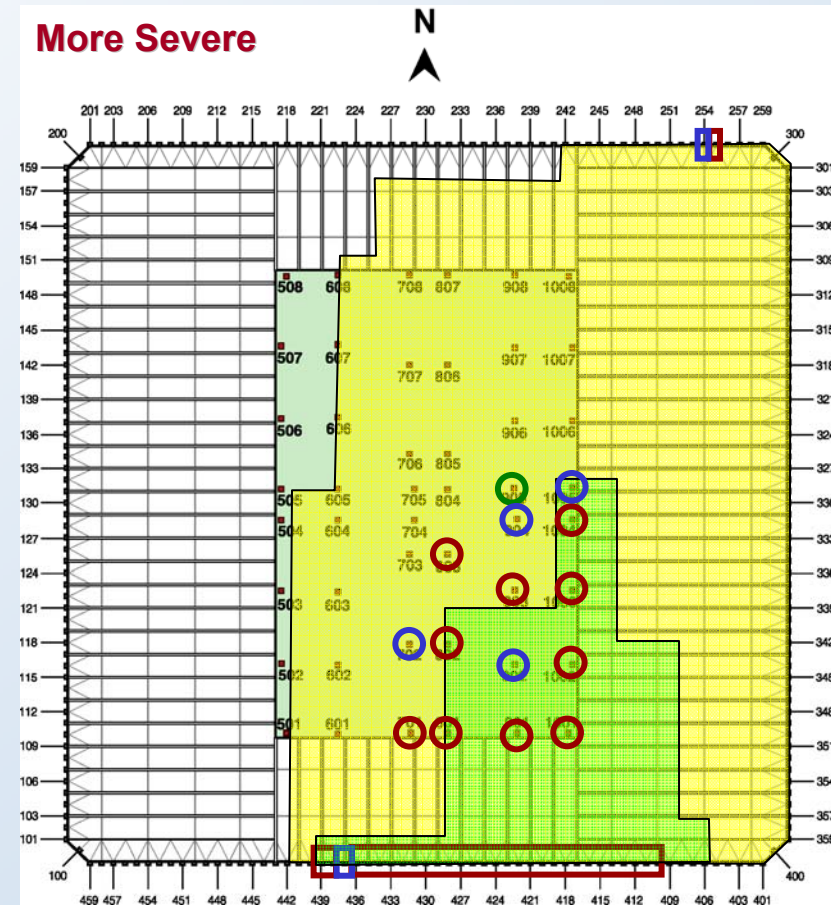

Displaced Shape of WTC 1 After Aircraft Impact (10x)

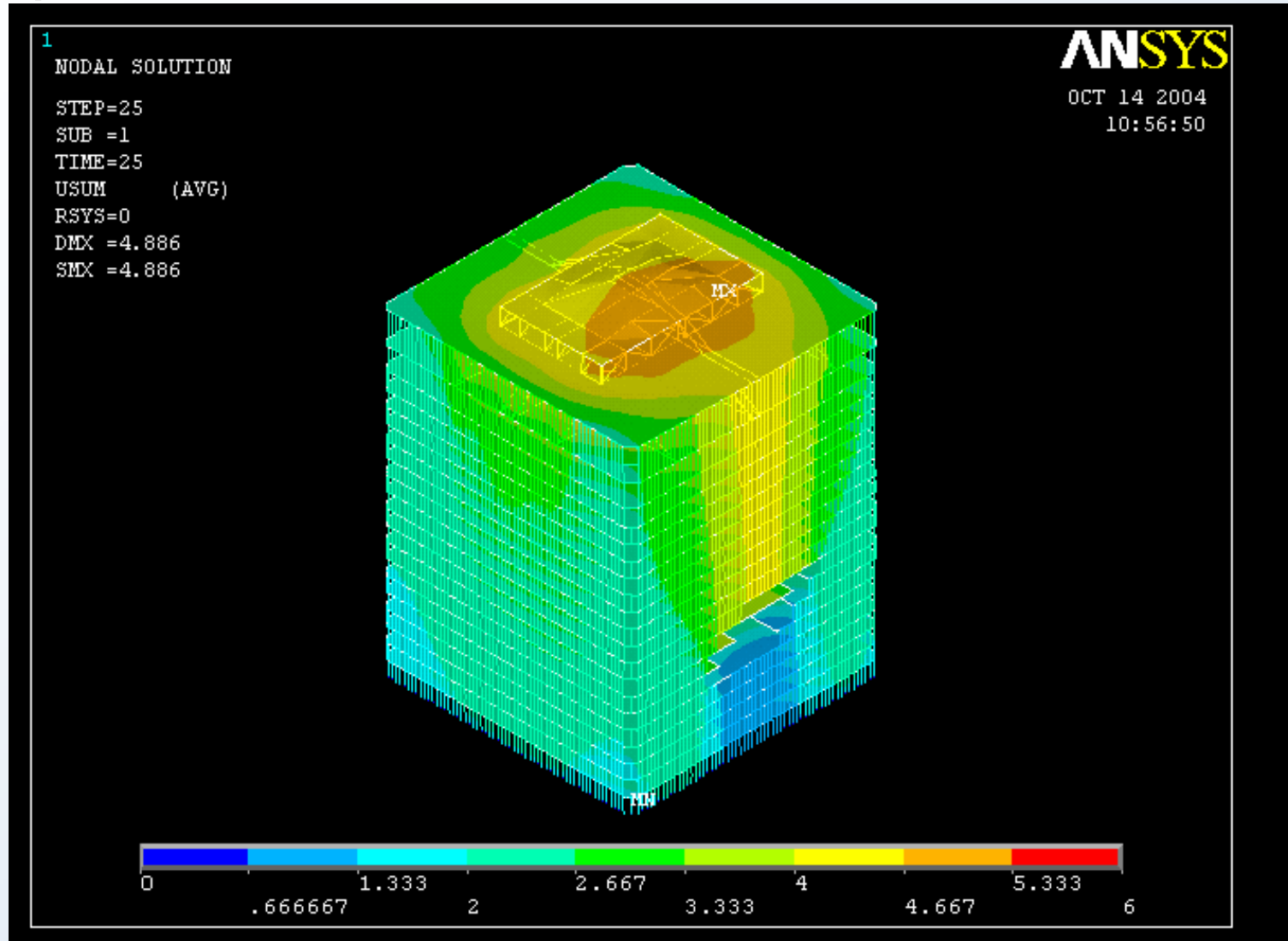

Axial Stress in North Face Components After Aircraft Impact in WTC1 (10x)

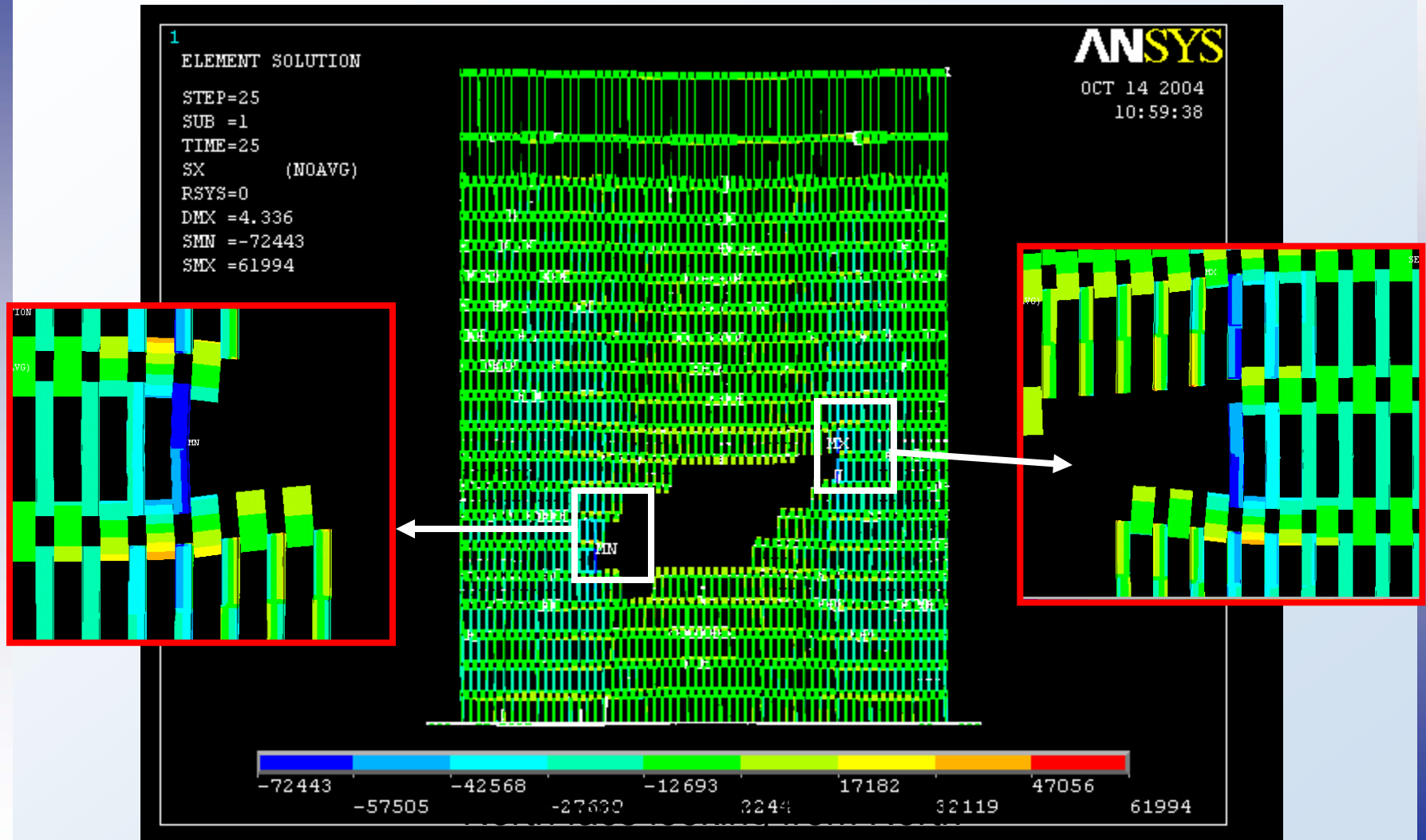

Stresses in Other Faces After Aircraft Impact in WTC1 (10x)

Combined axial and bending stresses are:

- below 28 ksi ($DCR \leq 0.3$) in the South face
- below 26 ksi ($DCR \leq 0.2$) in the East and West faces

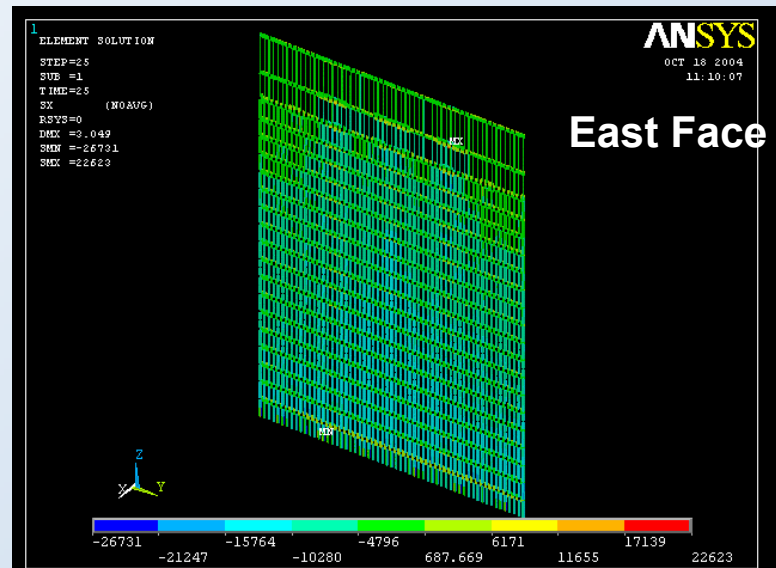
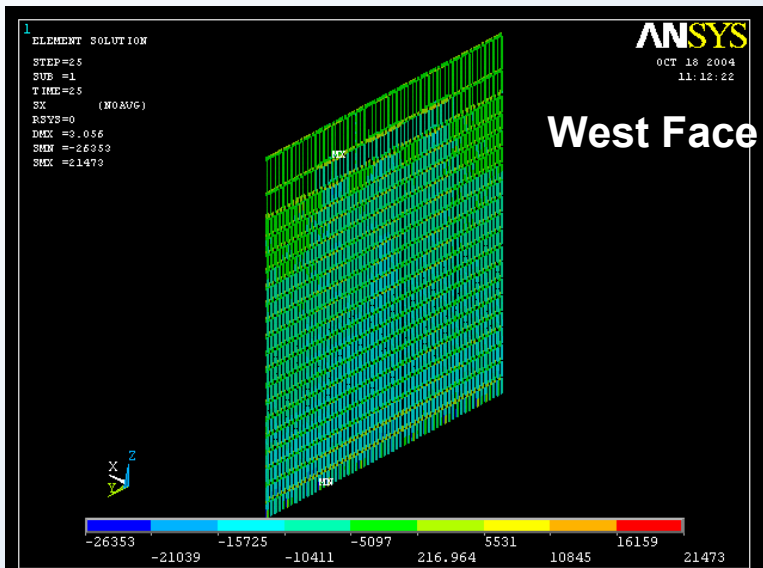
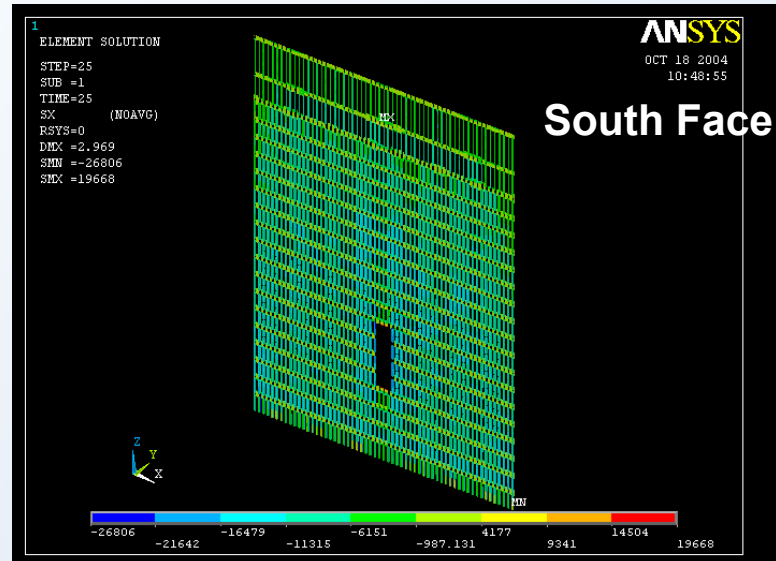

Axial Stress in Core & Hat Truss Members After Aircraft Impact

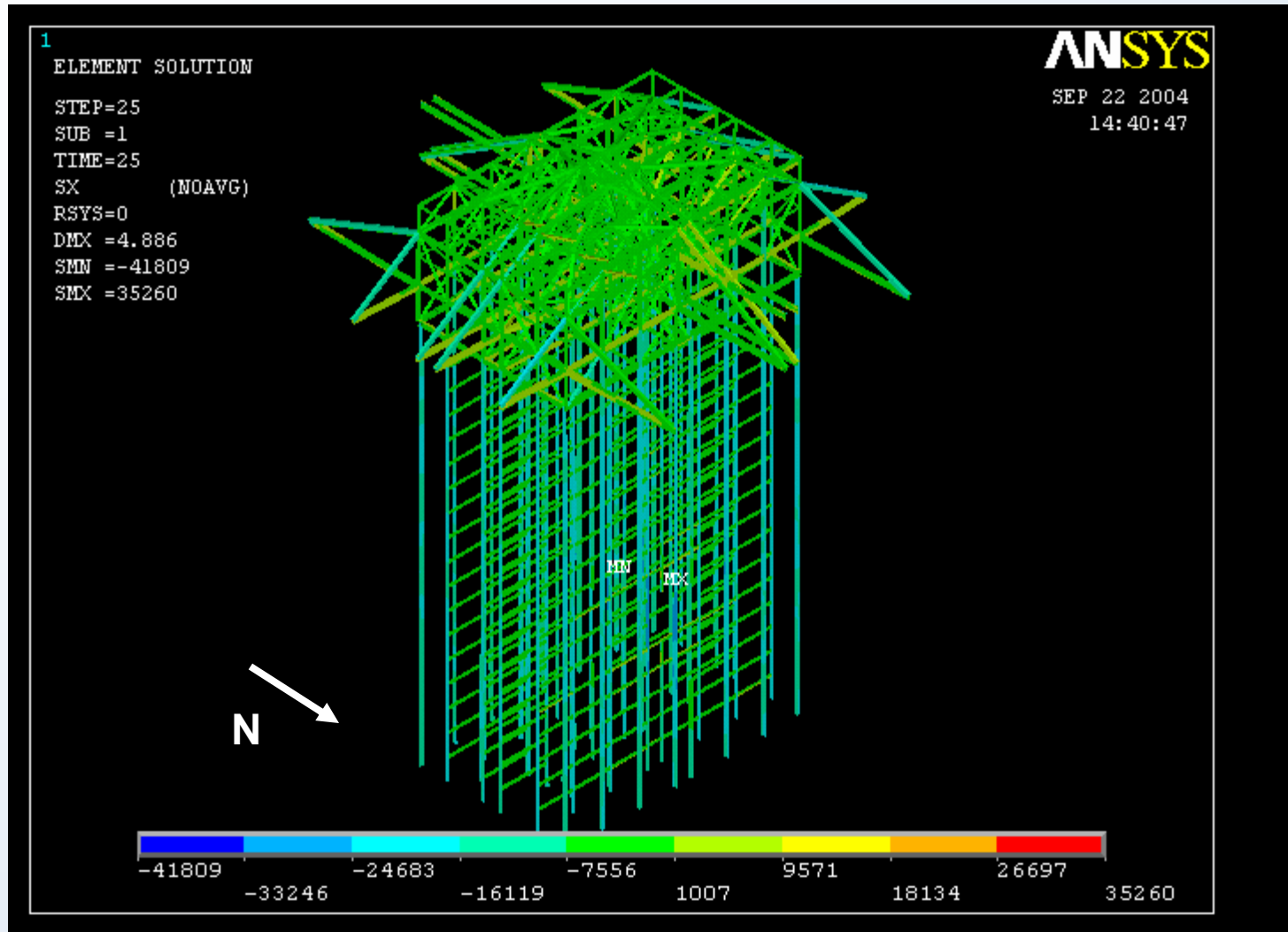

Axial Load Totals of Columns in WTC 1 Between Floors 98 and 99

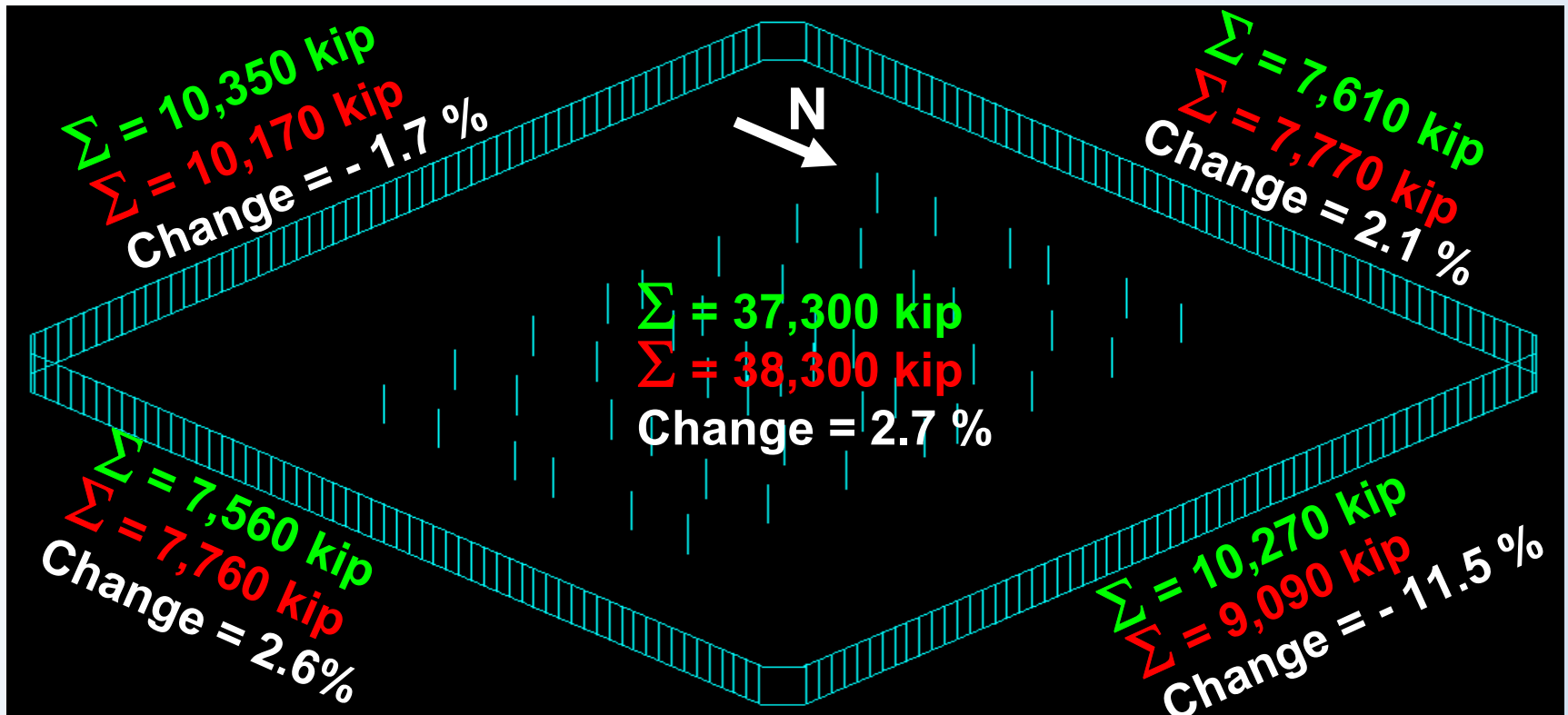

• Compression is positive

█ Before aircraft impact

█ Right after aircraft impact

Column Demand/Capacity Ratios Before Aircraft Impact in WTC 1 (Floors 93 to 98)

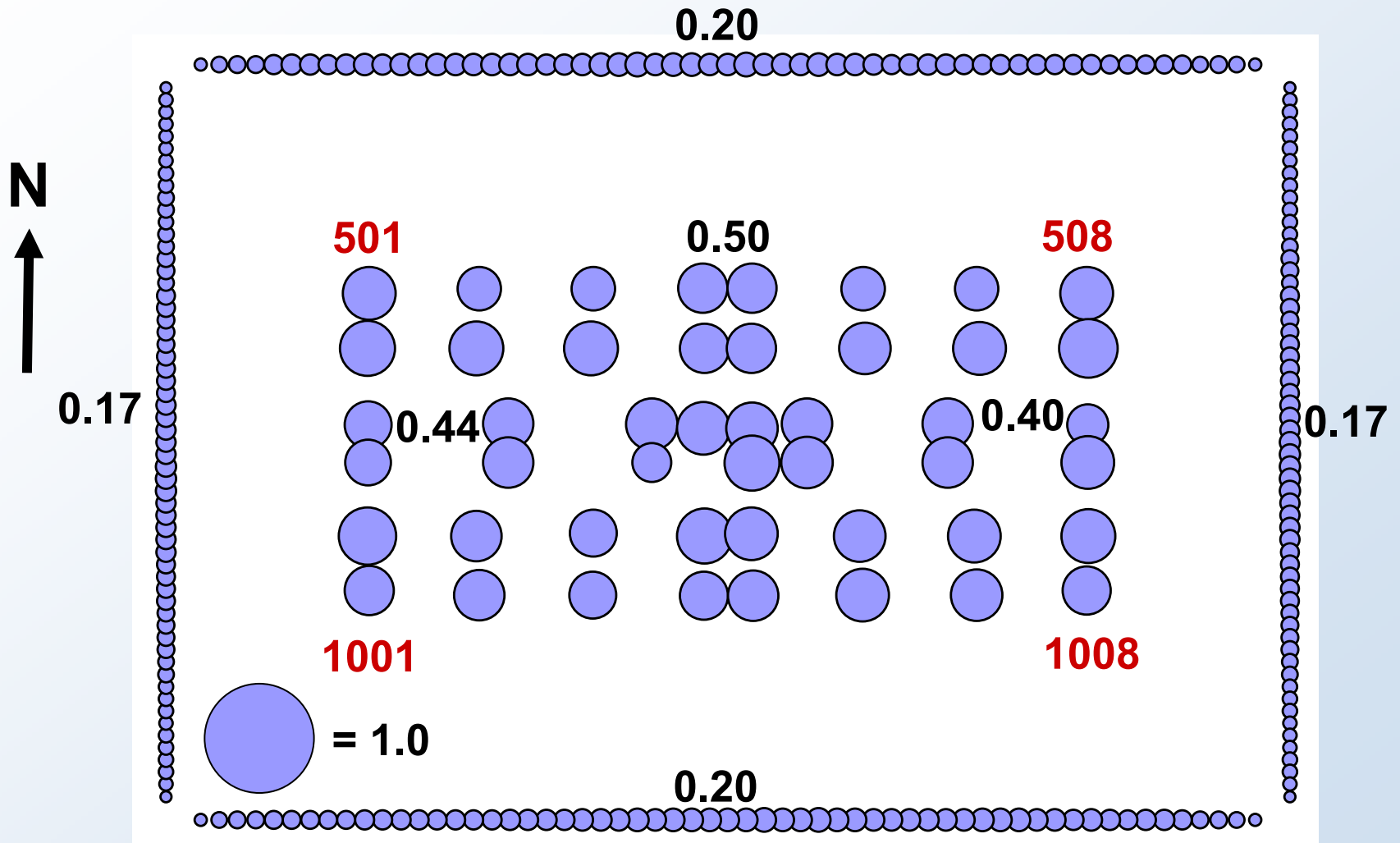

Column Demand/Capacity Ratios After Aircraft Impact in WTC 1 (Floors 93 to 98)

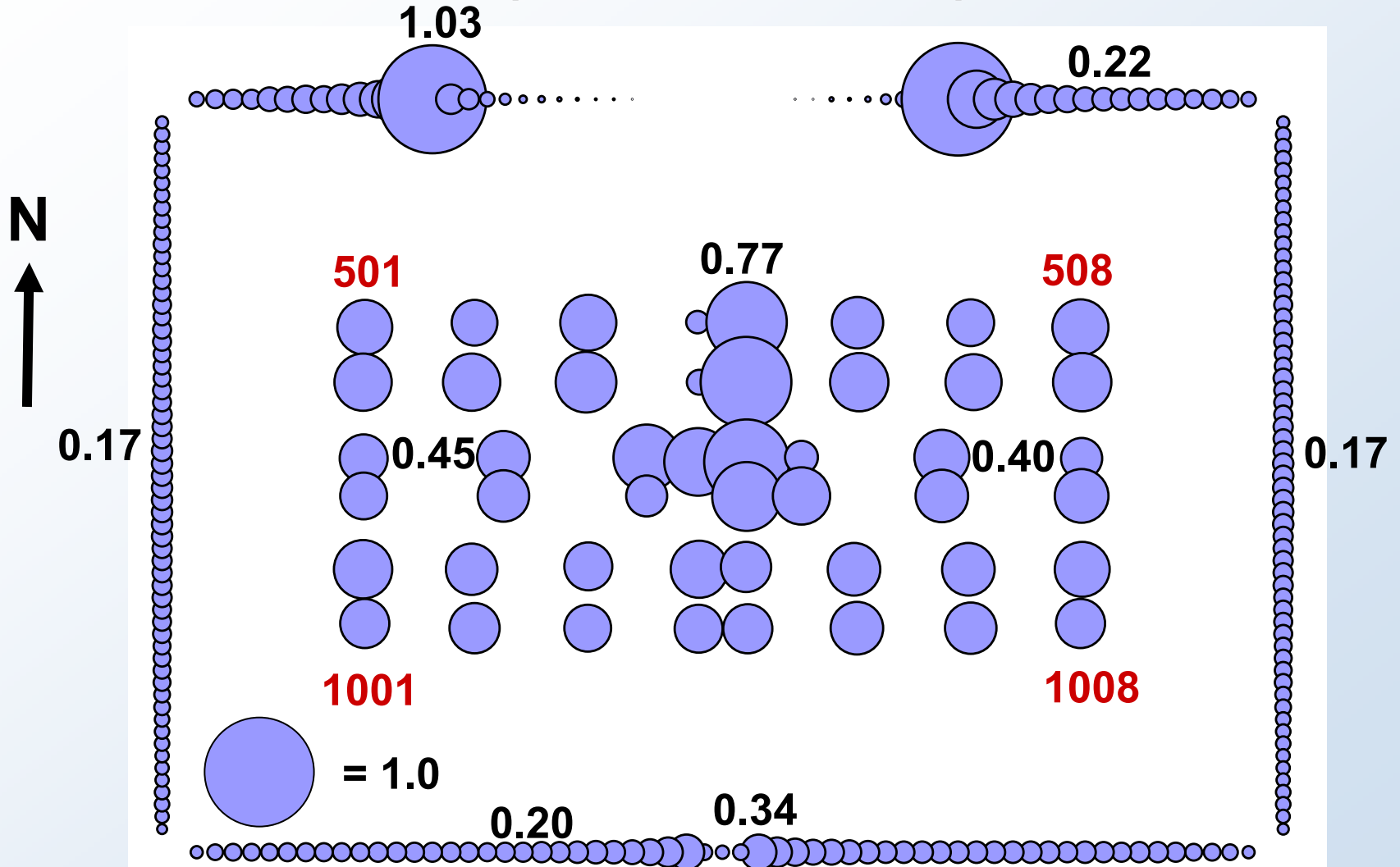

Findings for Global Analysis With Impact: Structural Response to Aircraft Impact Damage

Structural and passive fire protection damage

- ❑ WTC 1 had 39 perimeter and 3 to 6 severed core columns - N side, center
- ❑ WTC 1 damage was primarily centered through the north face and floor area, the core, and into the south floor area
- ❑ WTC 2 had 29 perimeter and 5 to 10 severed core columns - SE side
- ❑ WTC 2 damage occurred primarily on the east side of the core and floor area

The analysis shows that WTC 1 did not collapse following aircraft impact, as was observed

- ❑ Loads redistributed to adjacent core columns and East and West perimeter walls
- ❑ Primary load redistribution path was the floor system, and to a lesser extent by the hat truss

The analysis shows that WTC 2 did not collapse following aircraft impact, as was observed

- ❑ Loads redistributed to adjacent core columns and East and South perimeter walls
- ❑ Primary load redistribution path was the floor system, and to a lesser extent by the hat truss on the east and south sides

Structural Response to Fires Subsequent to Impact Damage

These key structural response are presented in the following order:

- Core column shortening
- Perimeter column bowing and buckling
- Floors sagging and pulling

Column Shortening in WTC 1 Measured by Ratio of Plastic-to-Elastic Strain (Ductility) at 6000 s

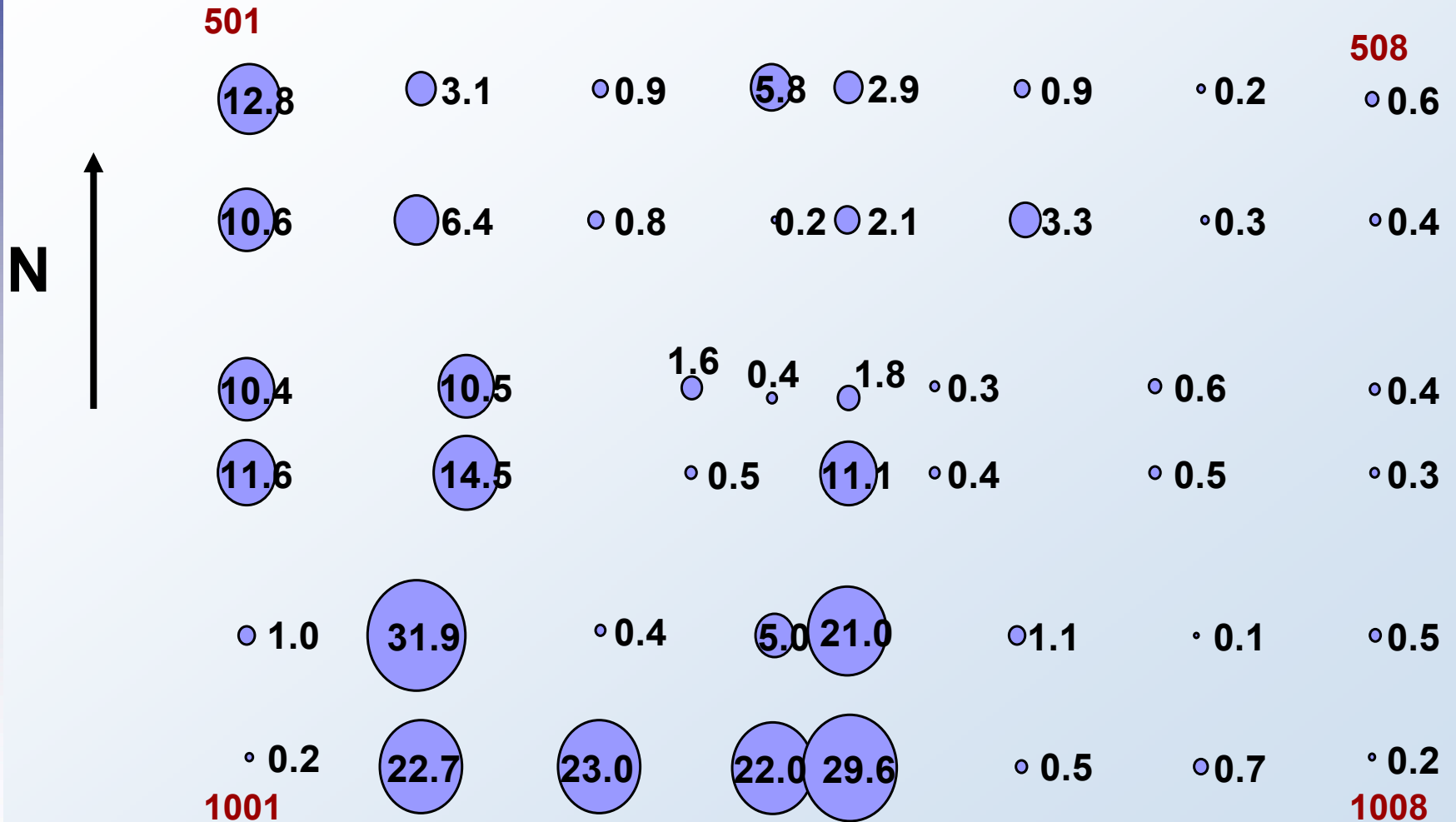

Creep and nonlinear buckling will increase core shortening

Buckling of Core Column 906 at Room Temperature Due to Displacement-Induced Collapse Analysis

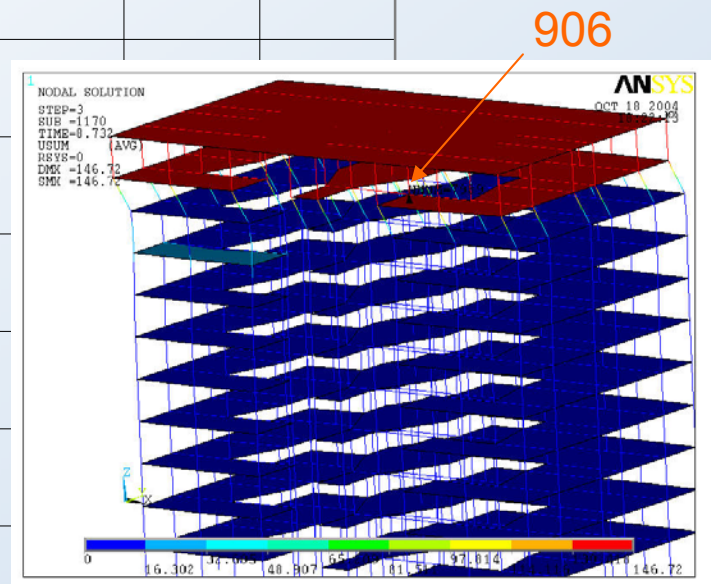
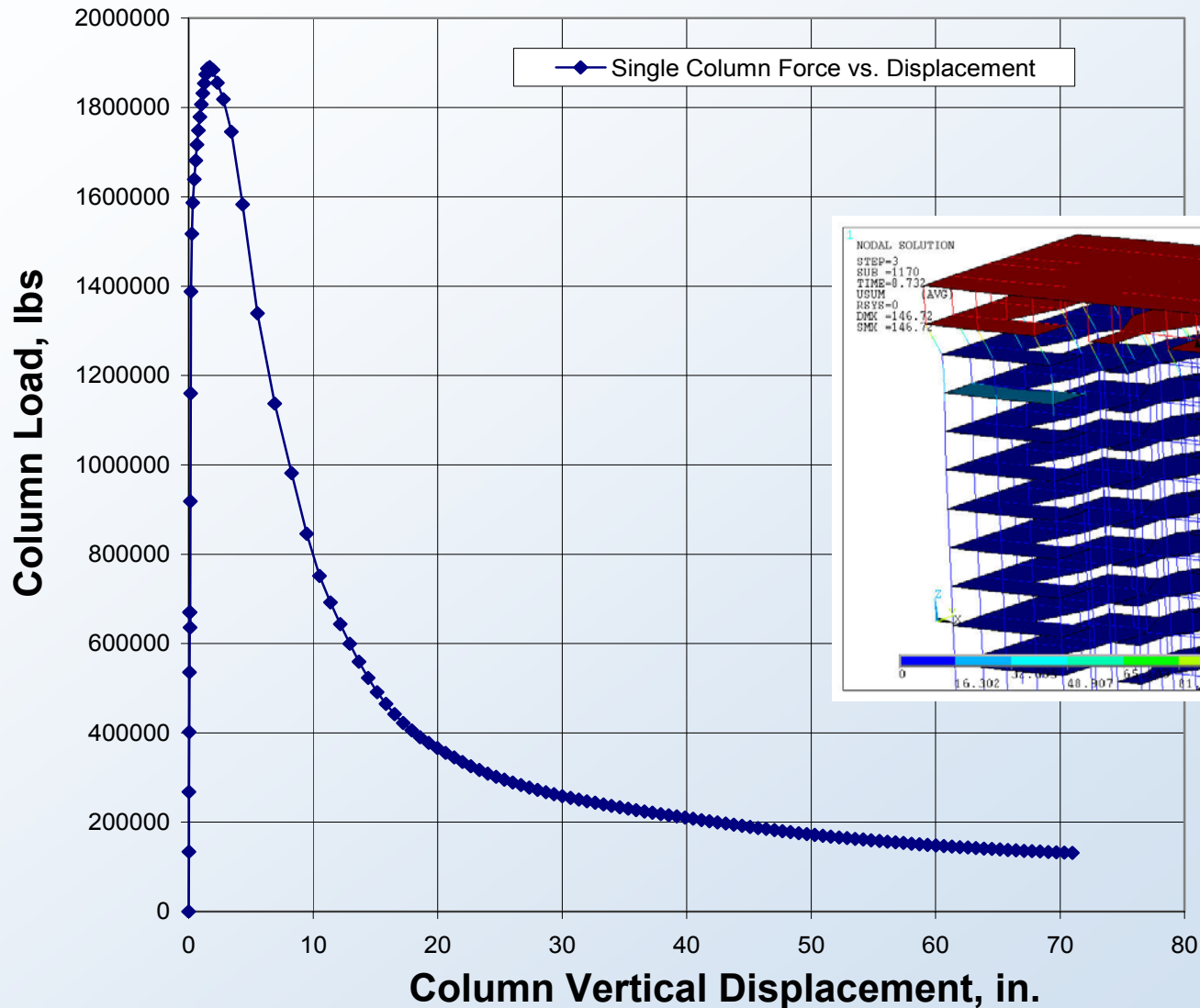

Findings for Global Analysis With Impact Damage: Structural Response of Core Columns to Fires

Combination of fireproofing damage and fires resulted in columns reaching 500 °C to 700 °C after 10 to 20 minutes of exposure.

At 500 °C to 700 °C, columns softened and shortened, through yielding or buckling, sufficiently to redistribute their loads to adjacent core columns and perimeter columns primarily through the floors.

A large number of columns, more than half, redistributed their loads after shortening to remaining core columns.

As the number of shortened core columns increased, the core area displaced downward relative to the perimeter, and the truss floors transferred loads (horizontal pulling and vertical loads) to the perimeter columns.

Core column response to fire and damage can be generally described as follows:

- ❑ WTC 1 columns softened, leading to the greatest column shortening on the south side.
- ❑ WTC 2 columns softened from east towards the core center, with core column shortening greatest on the east side

Perimeter Column Bowing in the South Face of WTC1



Perimeter Wall System Under Typical Fire Scenarios

A Perimeter Wall Section was analyzed for two load conditions under typical fire scenarios:

- ❑ Lateral floor loads pulled inward on the wall until column buckling occurred
- ❑ Vertical loads pushed down on the upper wall section until column buckling occurred

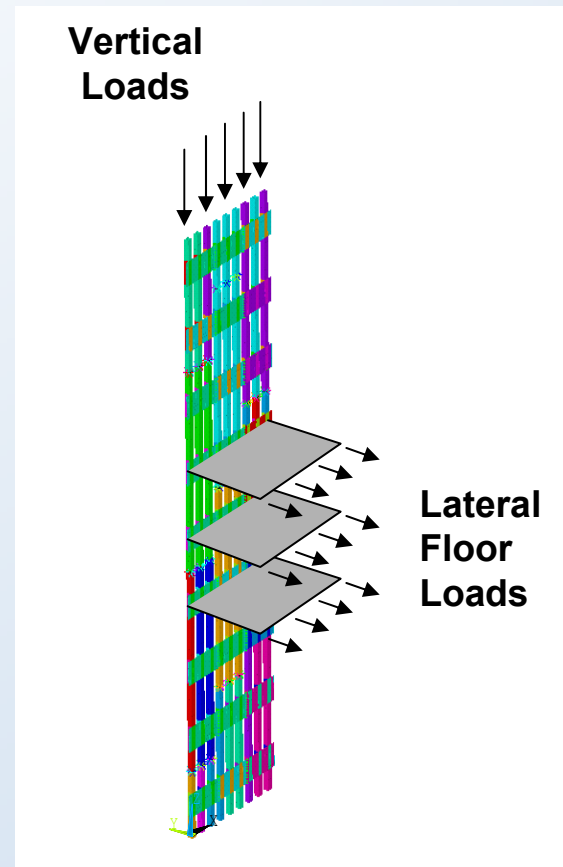

Perimeter Wall System and Typical Thermal Loading Condition

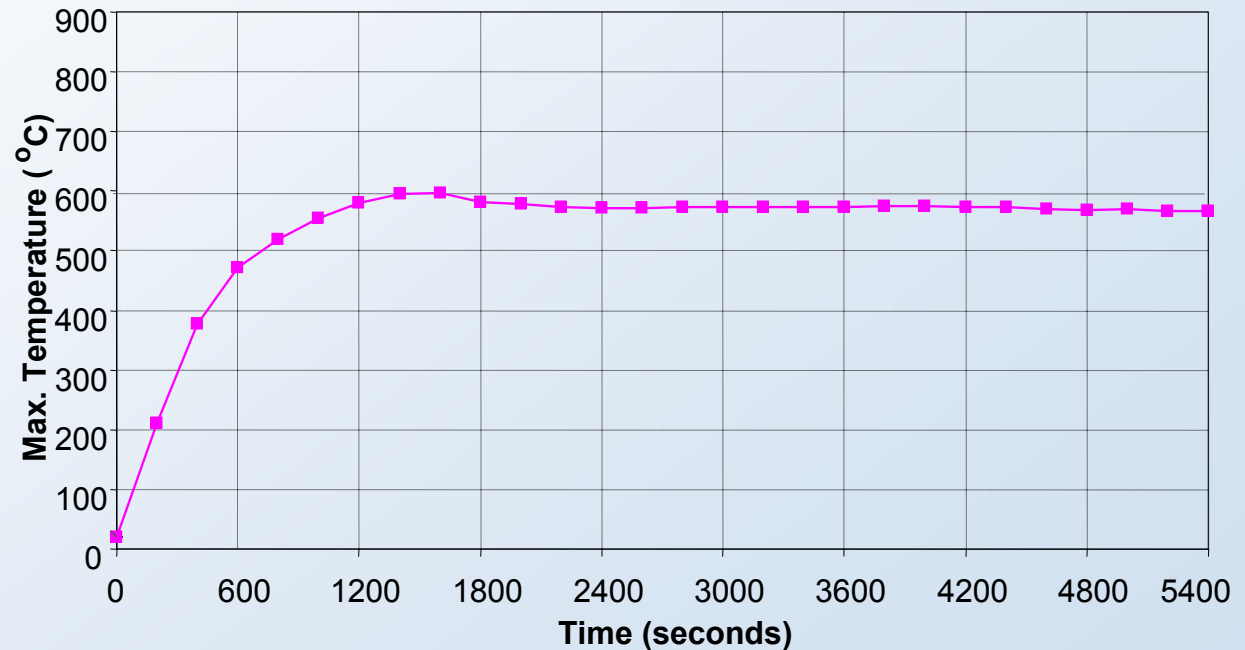
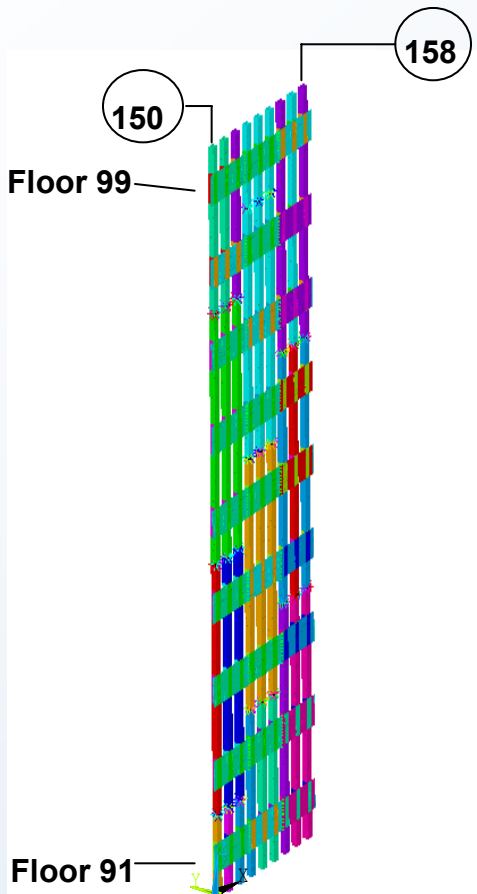

Gravity, Thermal and Pushdown Load with 3 Floors Unrestrained by Floor Slabs

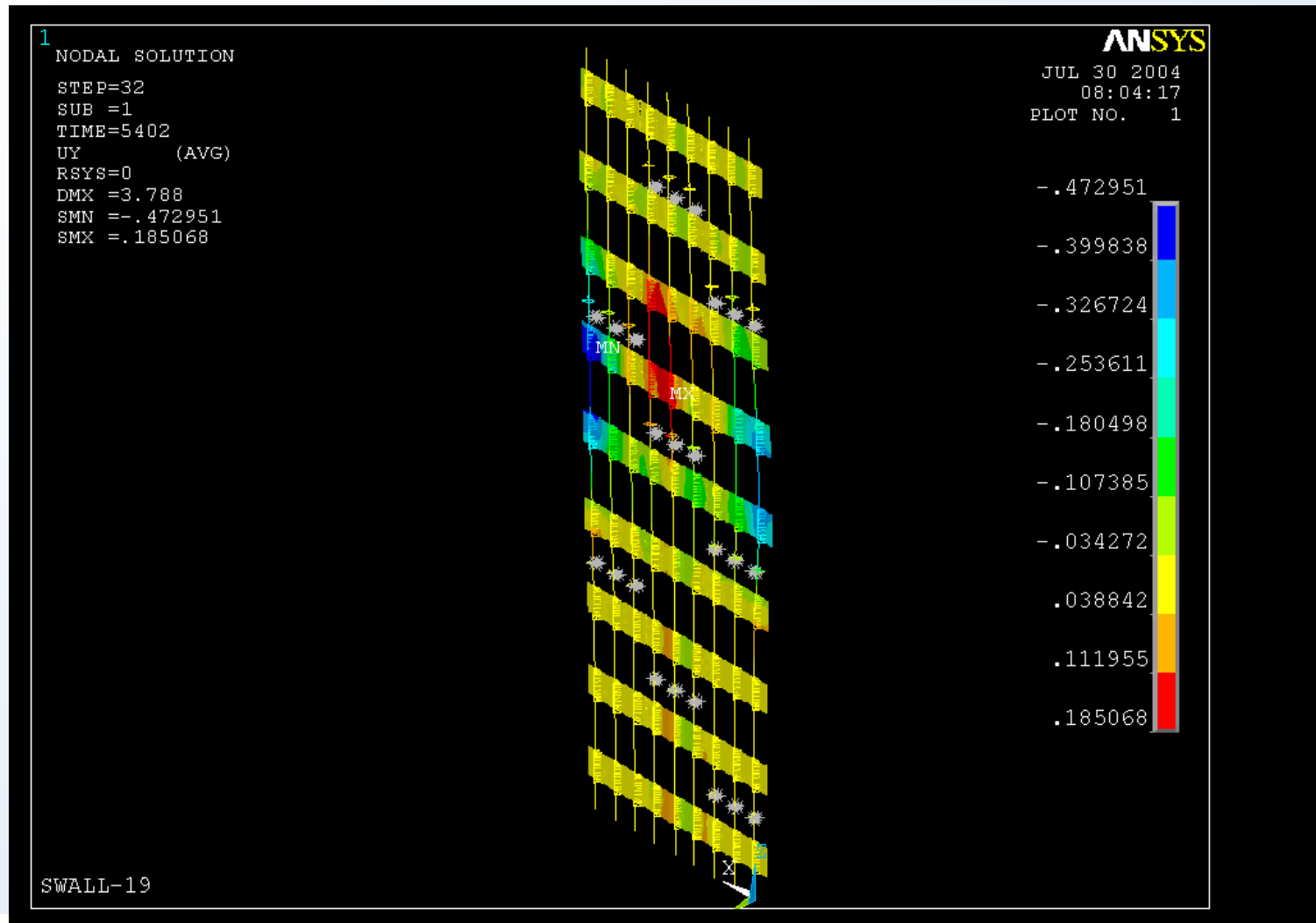

Gravity and Thermal Load with 3 Floors Pulling Inward

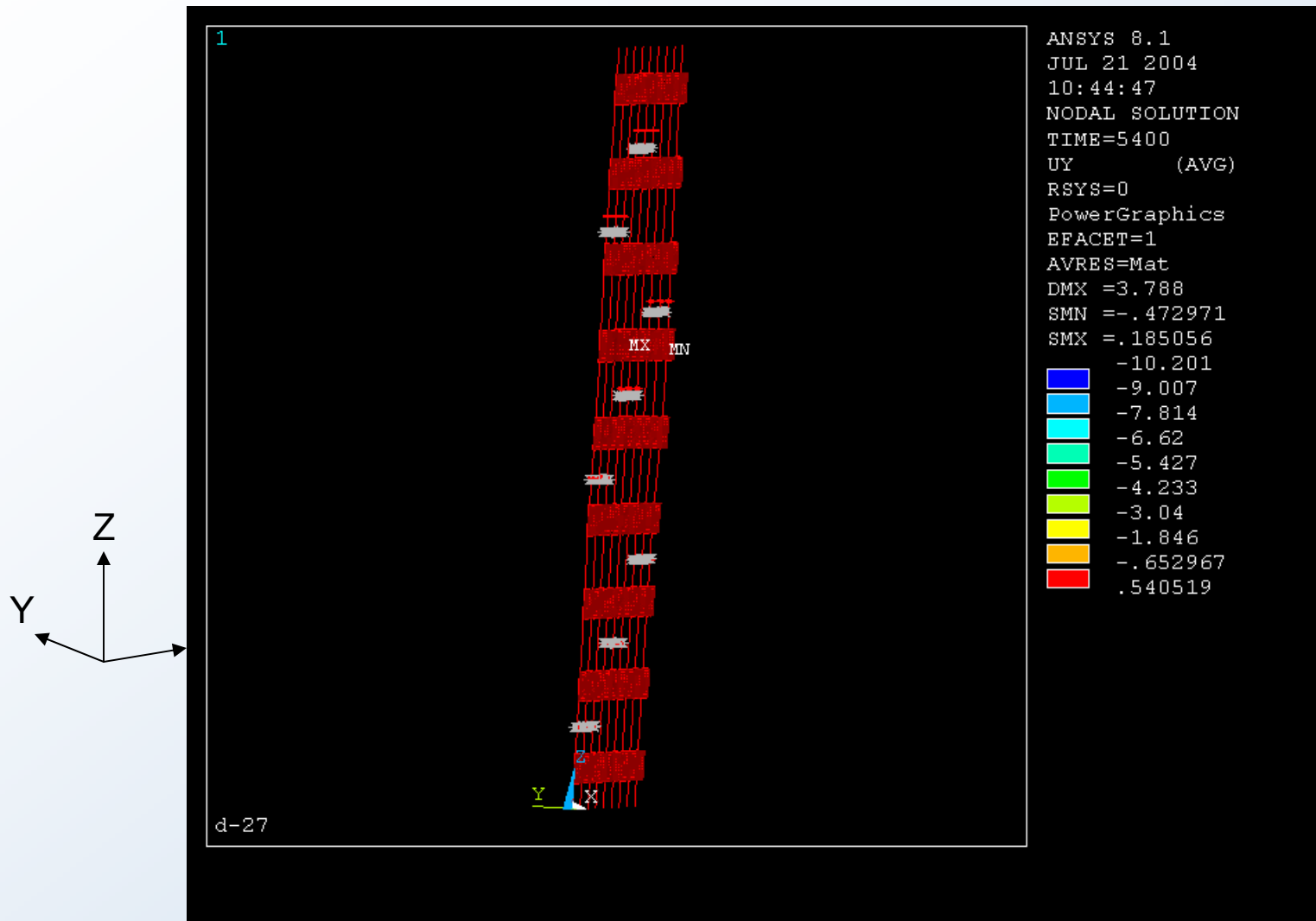

Findings for Global Analysis With Impact Damage: Structural Response of Perimeter Columns to Fires

Inward column bowing was observed on the south face of WTC 1 and east face of WTC 2 approximately 5 to 10 minutes prior to collapse.

This behavior has been modeled with component and global analyses with the combined effects of

- ❑ elevated temperatures,
- ❑ additional loads transferred to the perimeter columns, and
- ❑ inward pulling by floors.

The perimeter columns were loaded to 1/5 of their capacity prior to impact and were capable of large load transfers from the core columns via the floors and hat truss

Full Floor Model

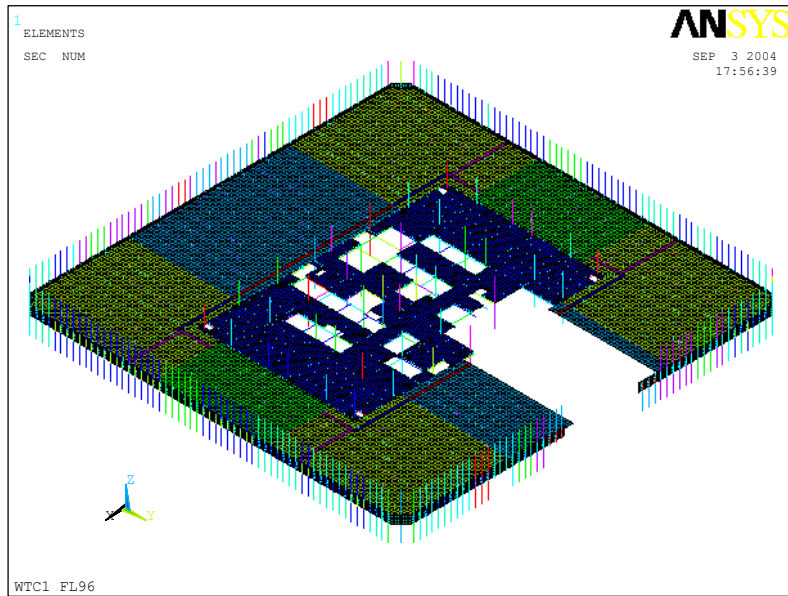

With Slab

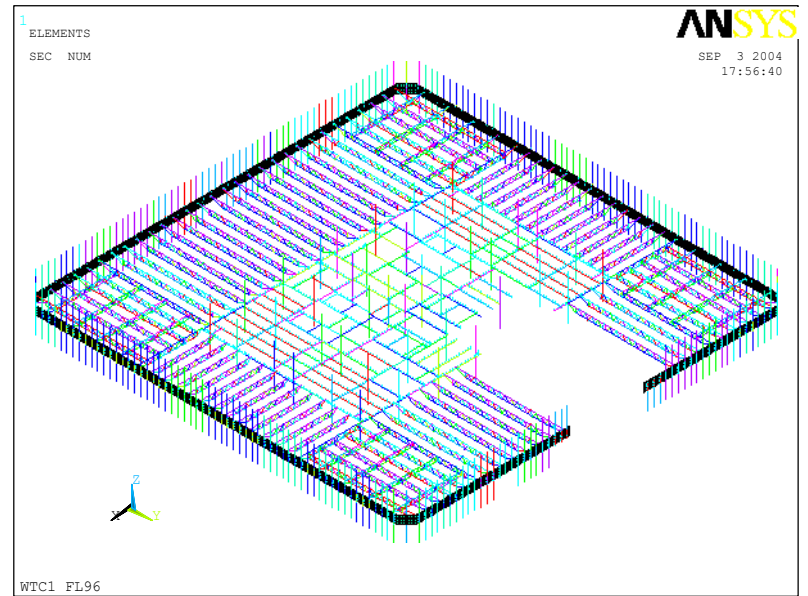

Without Slab

Structural Damage to WTC 1 Floor 96 from Realistic Impact Analysis

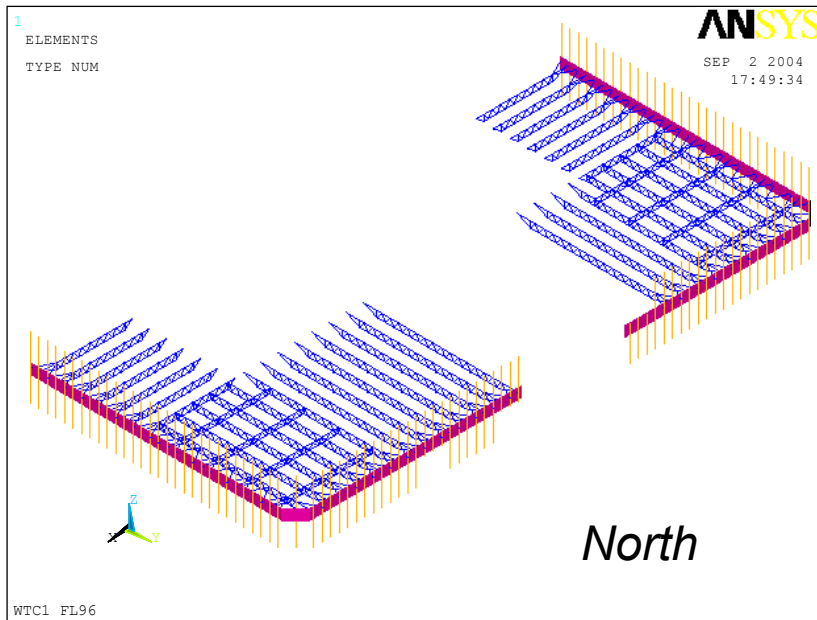

Floor trusses with damage

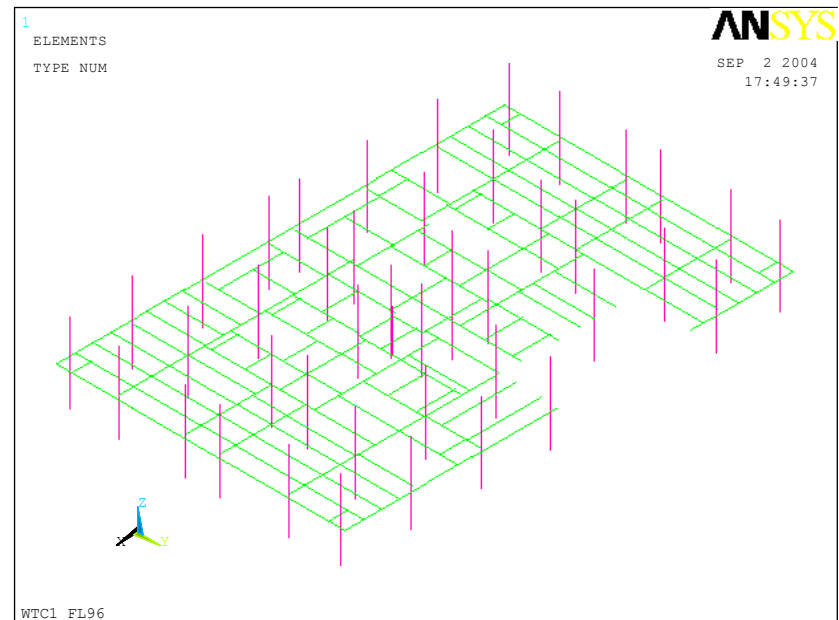

Core with damage

Temperature Distributions for Bottom of Slab of WTC 1 Floor 96 for Realistic Fires

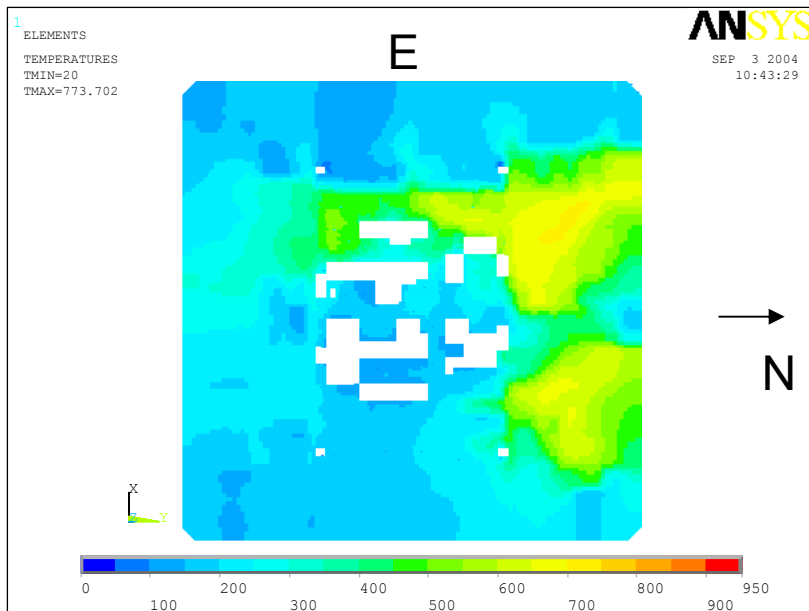

600 s

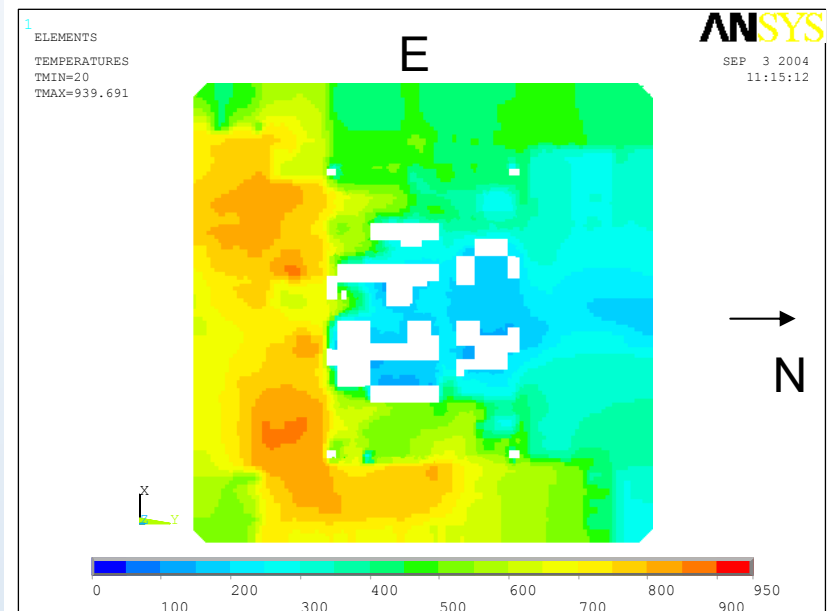

6000 s

Vertical Displacement for WTC 1 Floor 96 for Realistic Fires

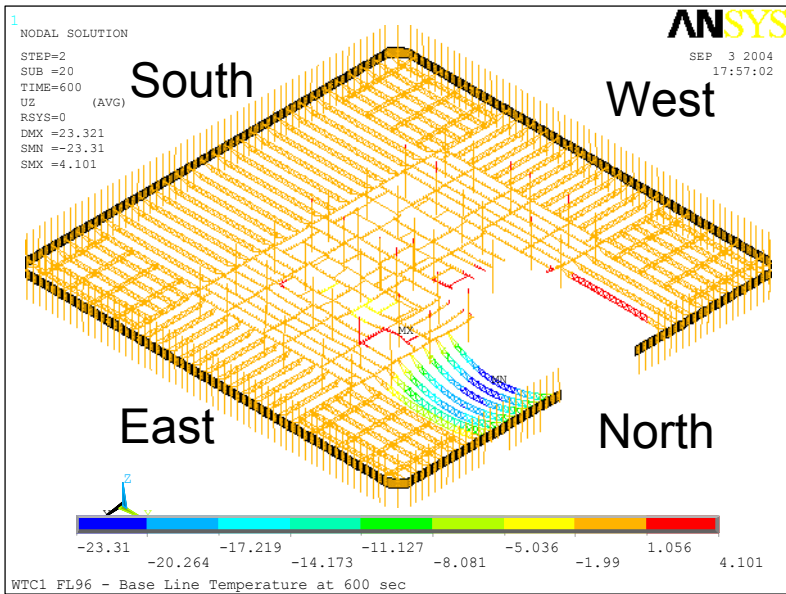

600 s

Maximum vertical displacement = 23 in.

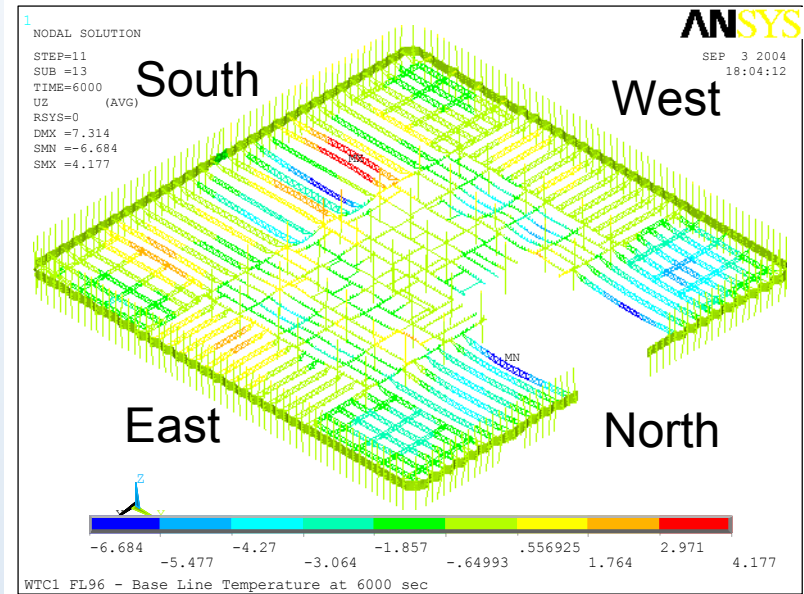

6000 s

Maximum vertical displacement = 6 in.

Temperature Distributions for Bottom of Slab of WTC 1 Floor 96 for More Severe Fires

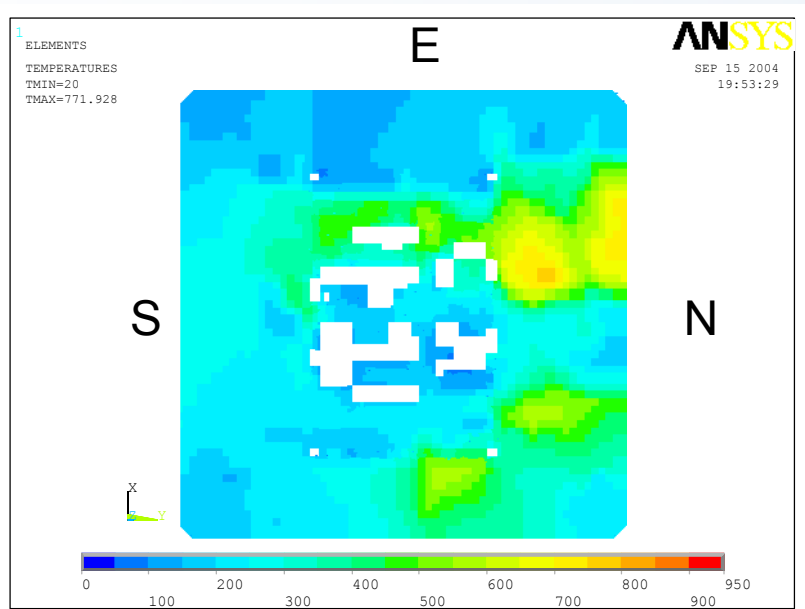

600 s

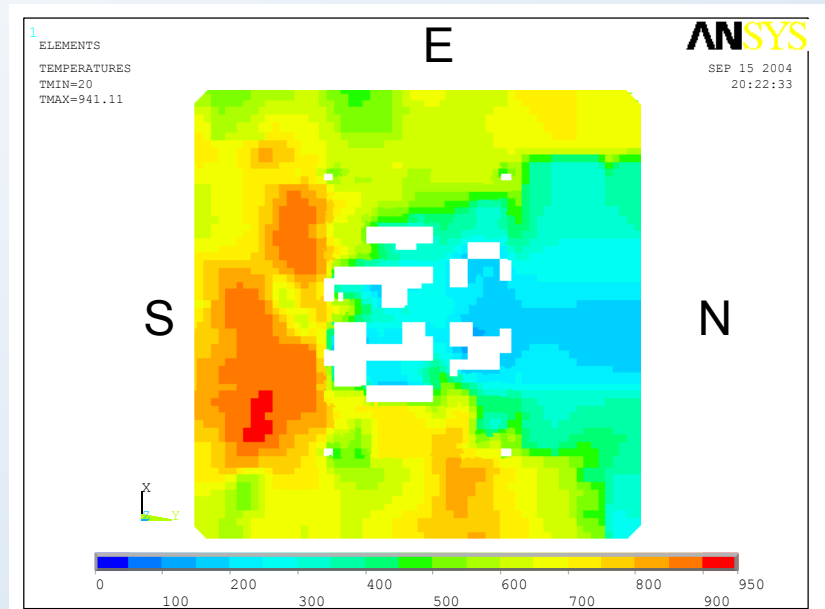

6000 s

Floor 96

Vertical Displacement for WTC 1 Floor 96 for More Severe Fires

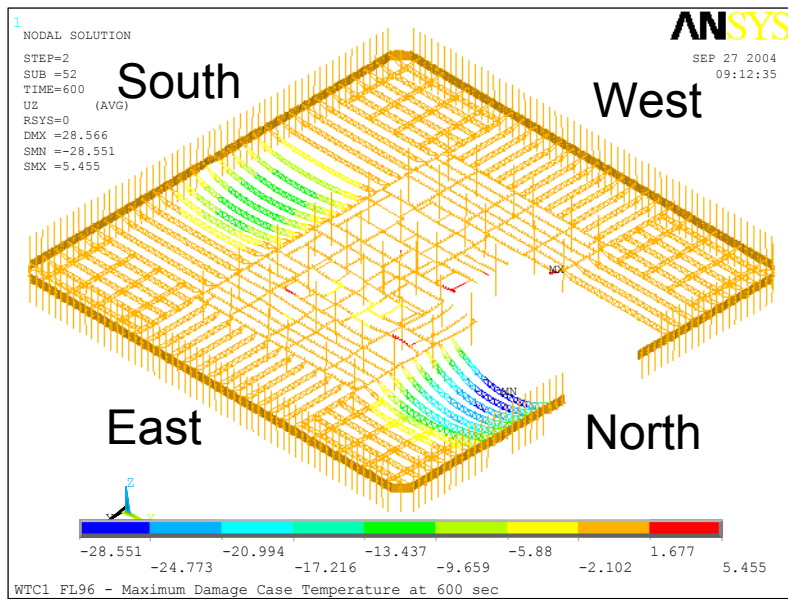

600 s

Maximum vertical displacement = 28.6 in.

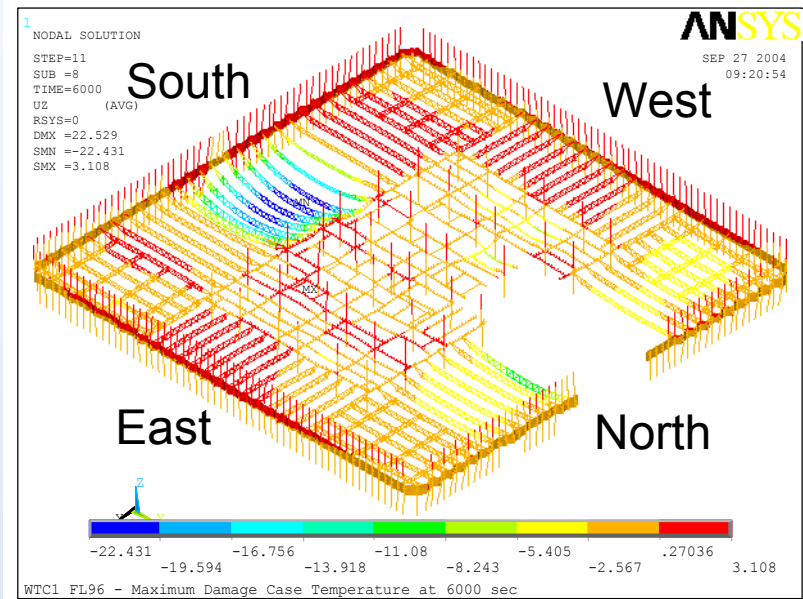

6000 s

Maximum vertical displacement = 22.4 in.

Temperature Distributions for Bottom of Slab of WTC 2 Floor 81 for Realistic Fires

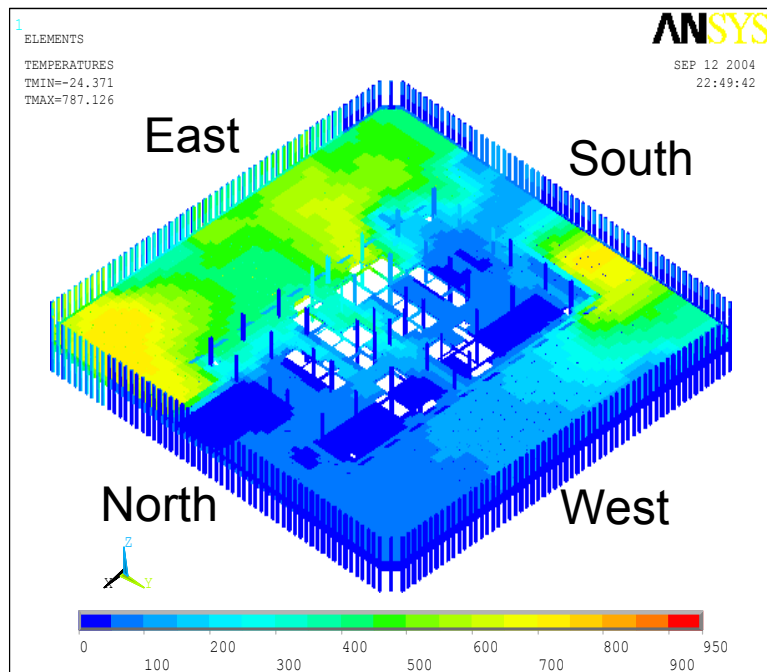

600 s

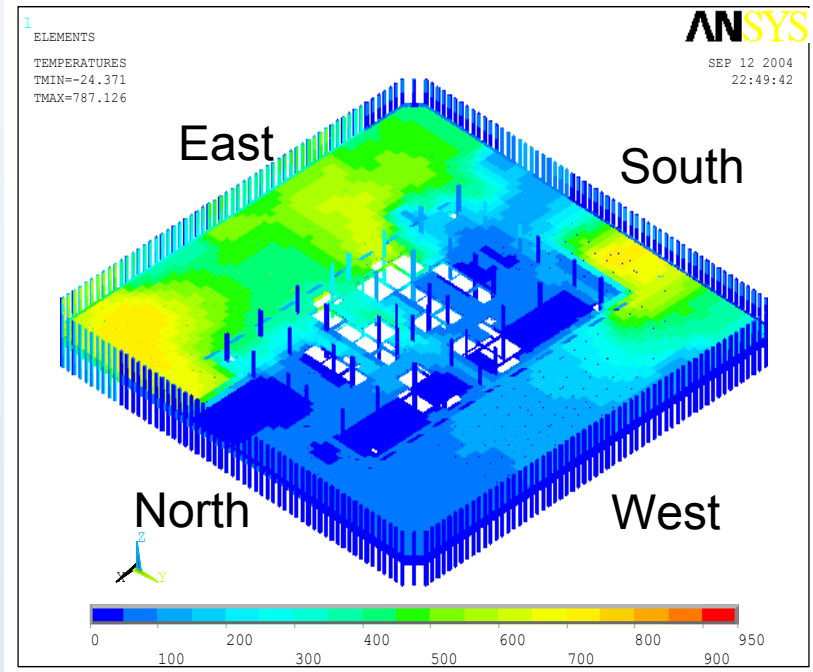

3600 s

Floor 96

Vertical Displacement for WTC 2 Floor 81 for Realistic Fires

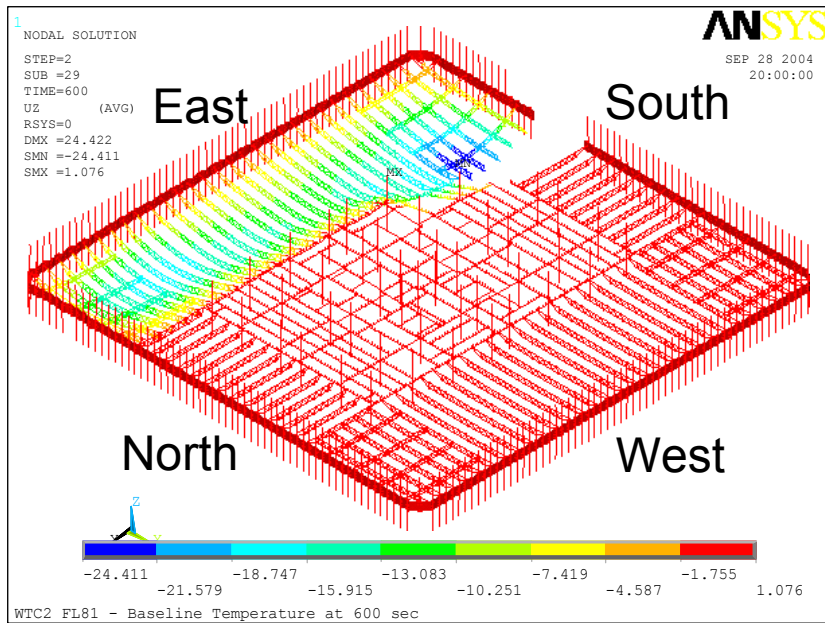

600 s

Maximum vertical displacement = 24 in.

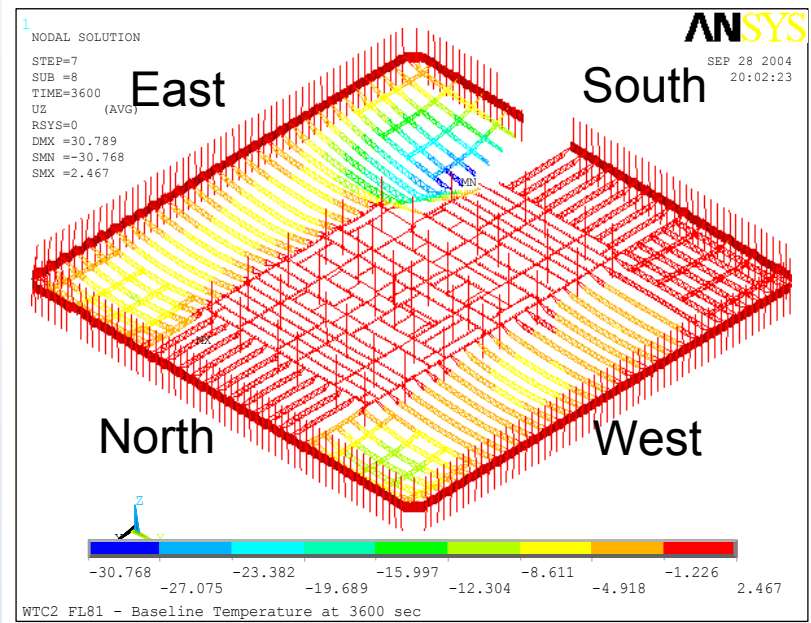

3600 s

Maximum vertical displacement = 31 in.

Findings for Global Analysis With Impact Damage: Structural Response of Floors to Fire (1)

Truss temperatures exceeded 500 °C to 600 °C **only** where fireproofing damage **and** fire exposure occurred. Trusses were observed to cool as fires moved to other areas, whereas concrete slab temperatures continued to rise.

WTC 1 Floor 96

- ❑ Damage to truss fireproofing was extensive near the impact area. For the realistic fires, the maximum floor deflection was 23 in and for the more severe fires the maximum floor deflection was 29 in.
- ❑ Damage to truss fireproofing on the south side was less extensive. For the realistic fires, the maximum floor deflection was 6 in and for the more severe fires the maximum floor deflection was 23 in.
- ❑ As slab temperatures rose for both fire cases, the slab expanded on the order of 2 to 4 in., and pushed outward on the perimeter columns.

Findings for Global Analysis With Impact Damage: Structural Response of Floor System to Fire (2)

WTC 2 Floor 81

- ❑ Damage to truss fireproofing was extensive near the impact area and across the east side. The maximum floor deflections were 24 in. for realistic fires.
- ❑ As slab temperatures rose, the slab expanded on the order of 2 to 4 in., and pushed outward on the perimeter columns. The exception was the southeast corner where failed truss connections at the core led to the floor system pulling inward on the perimeter columns.

The truss floor system provided a load redistribution path between the core columns and perimeter columns as their displacement relative to each other increased, limited by the capacity of the seated connections.

Example Analysis of Load Transfer Between Core and Perimeter Columns

A 12 in. downward displacement of core columns was imposed, producing the following results:

- ❑ An additional horizontal force of 7 to 8 kip pulled inward on the perimeter columns near the center of the face.
- ❑ An additional vertical force of 7 to 8 kip on the perimeter columns near the center of the face.
- ❑ A downward displacement of the core columns results in horizontal pulling and vertical forces acting on the perimeter wall, which accumulate to produce substantial forces at and above the impact and fire zone.

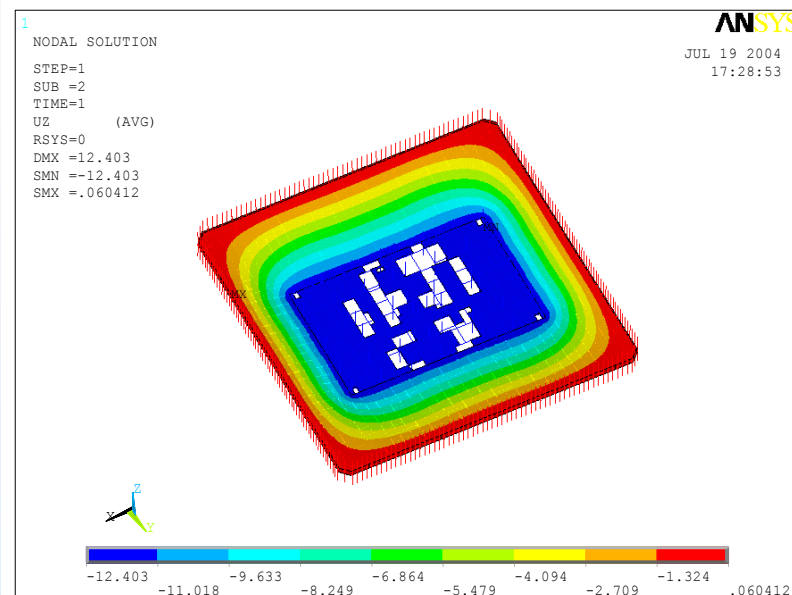

Final Analyses Currently Under Way

Phenomena governing stability (buckling) of columns

- ❑ Large plastic and creep deformations (squash)
- ❑ Kinking induced by localized plastic deformations

Stability analysis approaches for compressive buckling failure of columns

- ❑ Model actual geometrically and materially nonlinear kinking behavior at the component and subsystem level
- ❑ Equivalent plastic strain to failure criterion for column buckling in global analysis combined with break elements
- ❑ Calibrate the equivalent plastic strain-to-failure criterion with results from the detailed component and subsystem level models

Complete analyses for WTC 1 and WTC 2 with above improvements

Global analysis without damage

Global Analysis Without Impact Damage

Determine the structural response of the WTC towers to large fires without impact damage.

Based on what has been learned from Tasks 2 and 3, the current working hypothesis is:

- ❑ A WTC tower with upgraded fireproofing on the floor trusses would not have experienced significant heat-induced deformations, and it is likely that burnout would have occurred without collapse.
- ❑ A WTC tower with originally applied fireproofing in place may have experienced some heat-induced deformations of the truss floors, but it is likely that burnout would have occurred without collapse.

NIST expects to refine this working hypothesis based on analysis to be completed soon.

Issues – Structural Systems Performance and Failure Analysis

Availability of explicit standards, code provisions, methodology, analytical design tools, and practical design guidance for designing structures to resist progressive collapse in the event of abnormal loads

- ❑ Multihazard systems approach to structural design
- ❑ Coordination of ongoing federal and private sector efforts

Availability of analytical methodologies for prediction of complex failure phenomena of structural systems under abnormal loads:

- ❑ Proper identification of failure phenomenon to be analyzed
- ❑ Physics-based/phenomenological models and experimental validation
- ❑ Robust tools for routine analysis of such failures
- ❑ Magnitude of the problem that can be solved on existing computational platforms

Issues – Fire Safety Design of Structures

Availability of standards, codes, methodology, analytical design tools, and practical design guidance to permit considering fire as a design condition for the structure as a whole system. Also,

- ❑ Lack of standard methodology for evaluating thermo-structural vulnerability
- ❑ Creation of broad training opportunities for rigorous use of computational fire dynamics and thermo-structural analysis tools
- ❑ Method for rating the fire resistance of structural systems and barriers, for realistic design-basis fire scenario (as contrasted with furnace conditions)
- ❑ Structural principles education for fire protection engineers and fire protection principles education for structural engineers

Issues – Passive Systems for Fire Protection

Availability of regulations that would adopt code provisions using the “structural frame” approach to fire resistance ratings, which requires structural members (i.e., girders, beams, trusses, and spandrels having direct connection to the columns and bracing members designed to carry gravity loads) to be fire protected to the same rating as columns.

- Required by IBC 2000
- Under consideration for adoption by NFPA 5000

Applied passive fire protection (such as spray-applied fire-resistive materials) conformance to conditions in actual or equivalent tests used to establish fire resistance rating of the building component or assembly.

- Durability-related properties (under in-service exposure conditions) for acceptance and quality control
- Inspection of fire-resistive materials after installation of all mechanical and electrical systems
- Criteria for required average thickness based on variability of thickness
- Test and procedure to predict service life that accounts for application conditions (e.g., temperature, humidity)

Issues – General

Availability of regulatory requirements for retention of documents related to the design, construction, operation, maintenance, and modifications of buildings, including retention offsite.

- Maintenance and storage of documents
- Accessibility of building plans for emergency response