



US 20240133746A1

(19) **United States**

(12) **Patent Application Publication**
Klimov et al.

(10) **Pub. No.: US 2024/0133746 A1**

(43) **Pub. Date: Apr. 25, 2024**

(54) **PHOTONIC THERMOMETER MODULE ASSEMBLY AND PERFORMING PHOTONIC THERMOMETRY**

Publication Classification

(71) Applicant: **Government of the United States of America, as represented by the Secretary of Commerce, Gaithersburg, MD (US)**

(51) **Int. Cl.**
G01J 5/0821 (2006.01)
G01J 5/02 (2006.01)
G01K 15/00 (2006.01)
(52) **U.S. Cl.**
CPC *G01J 5/0821* (2013.01); *G01J 5/0205* (2013.01); *G01K 15/005* (2013.01)

(72) Inventors: **Nikolai Nikolaevich Klimov, Gaithersburg, MD (US); Tobias Kent Herman, Clarksburg, MD (US); Zeeshan Ahmed, Gaithersburg, MD (US)**

(57) **ABSTRACT**

A photonic thermometer module assembly includes: a sheath; a sheath bottom plug; a sheath top flange; a top sealing flange; a heat exchanger; a photonic thermometer disposed on the heat exchanger such that the photonic thermometer determines a temperature of the sheath; and an optical fiber array in optical communication with the photonic thermometer and that optically couples the photonic thermometer to an exterior environment of the photonic thermometer module assembly, wherein the photonic thermometer module assembly is compatible with International Temperature Scale of 0 (ITS-90) fixed-point cell infrastructure and conventional drywell and oil-bath calibrations, and the photonic thermometer module assembly provides temperature measurements from -200° C. to $+700^{\circ}$ C.

(21) Appl. No.: **18/121,052**

(22) Filed: **Mar. 13, 2023**

Related U.S. Application Data

(60) Provisional application No. 63/419,026, filed on Oct. 25, 2022.

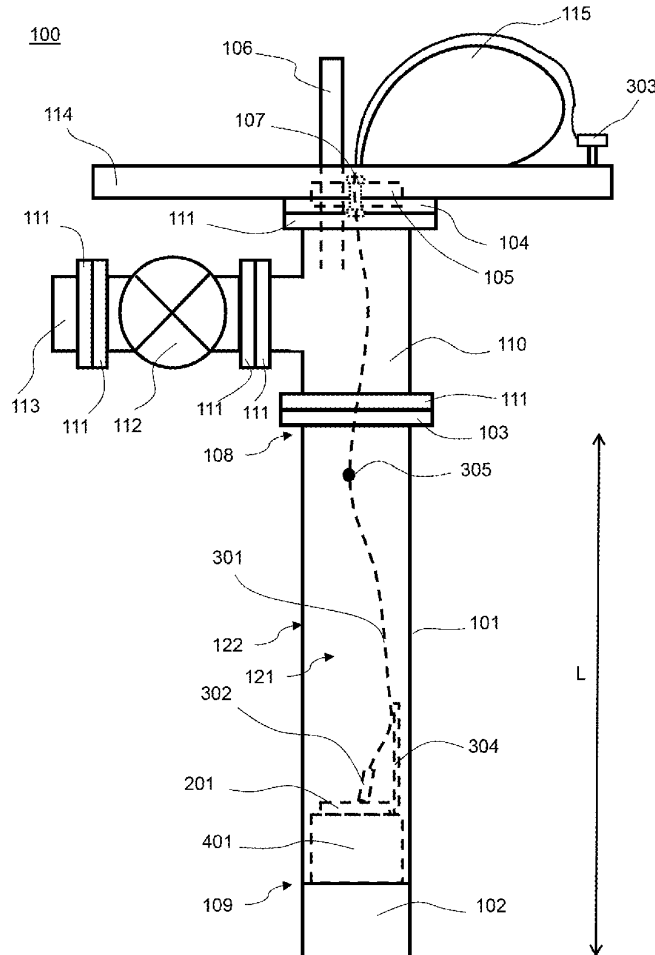

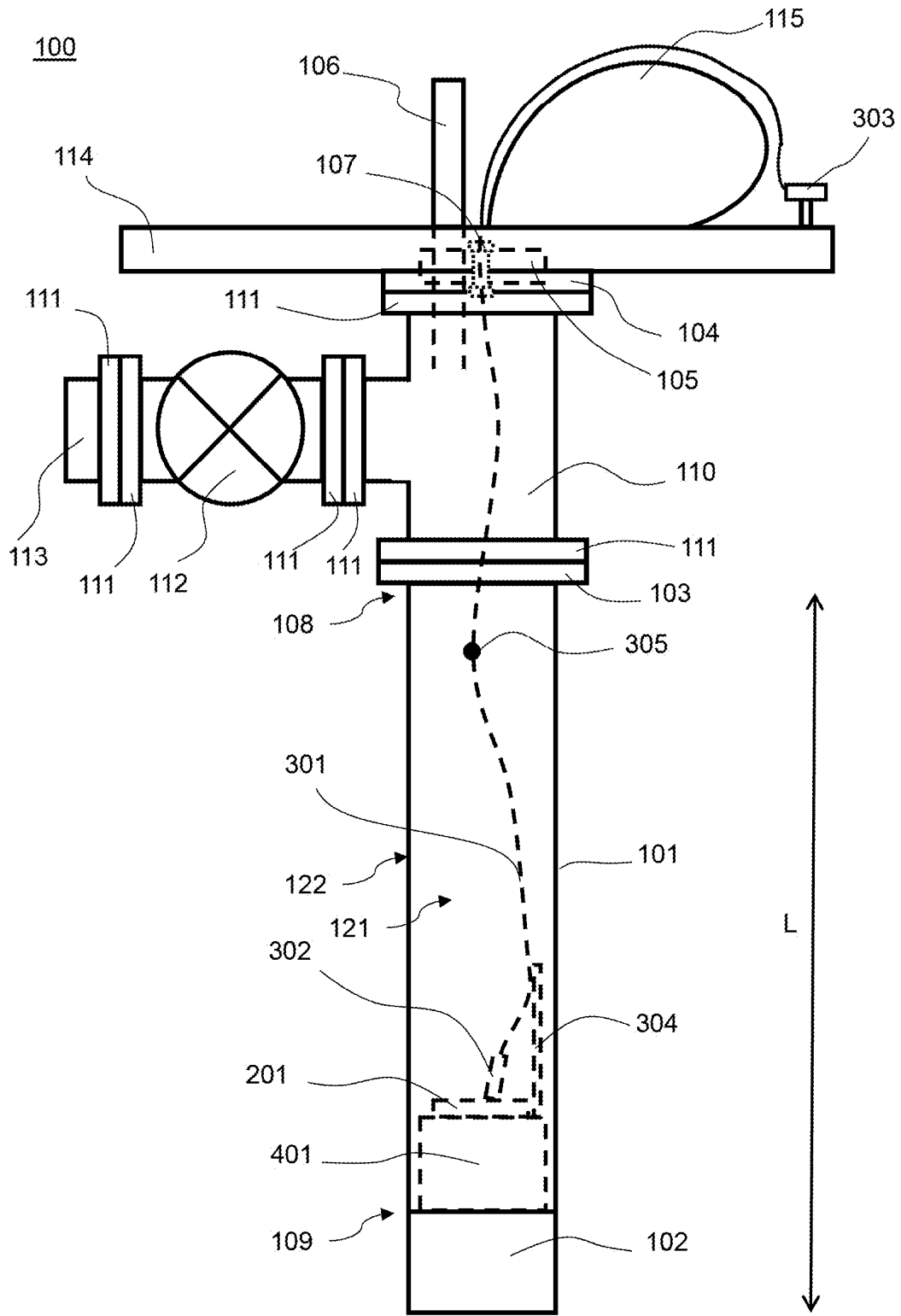

FIG. 1

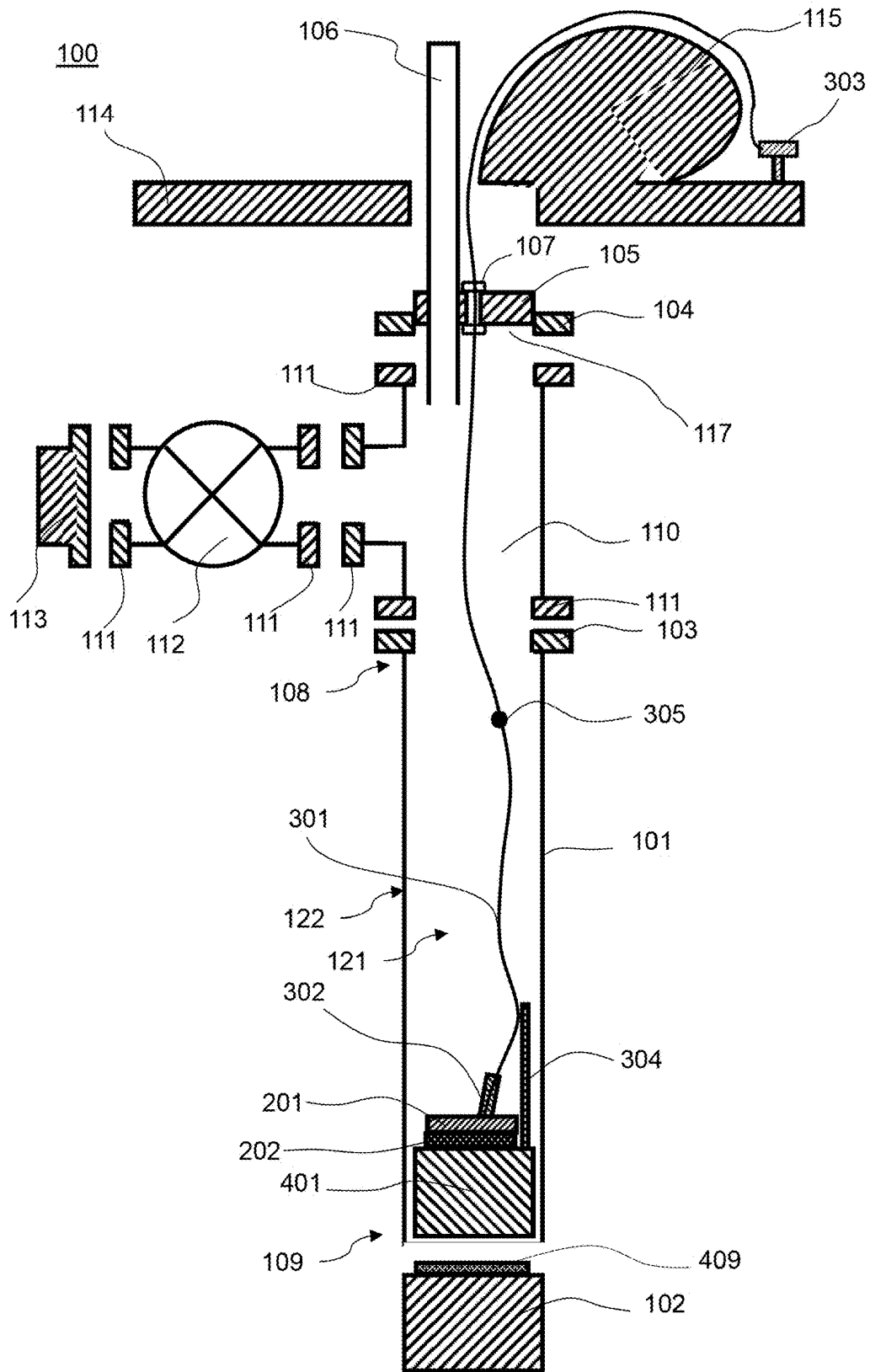
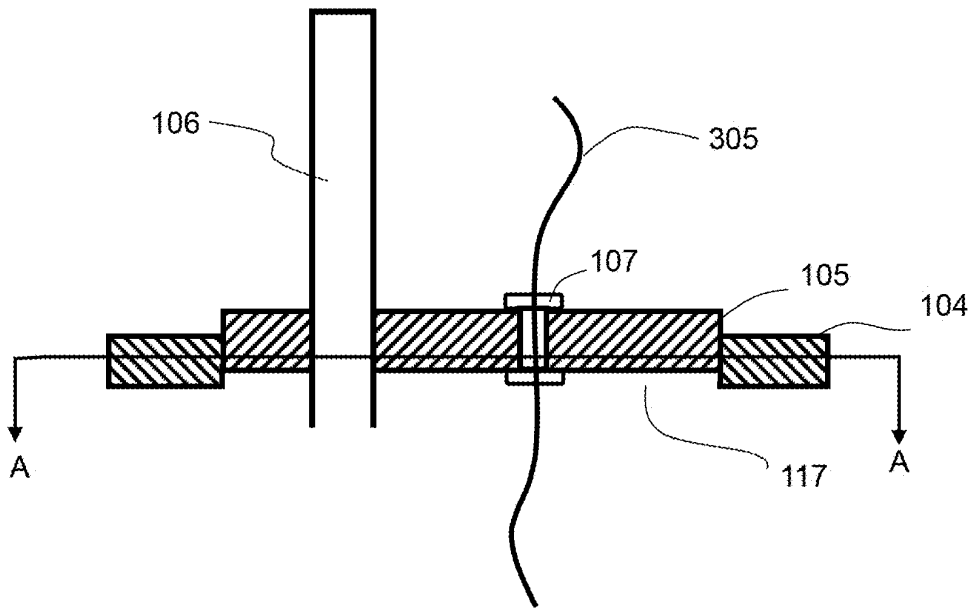

FIG. 2



A-A CROSSSECTION

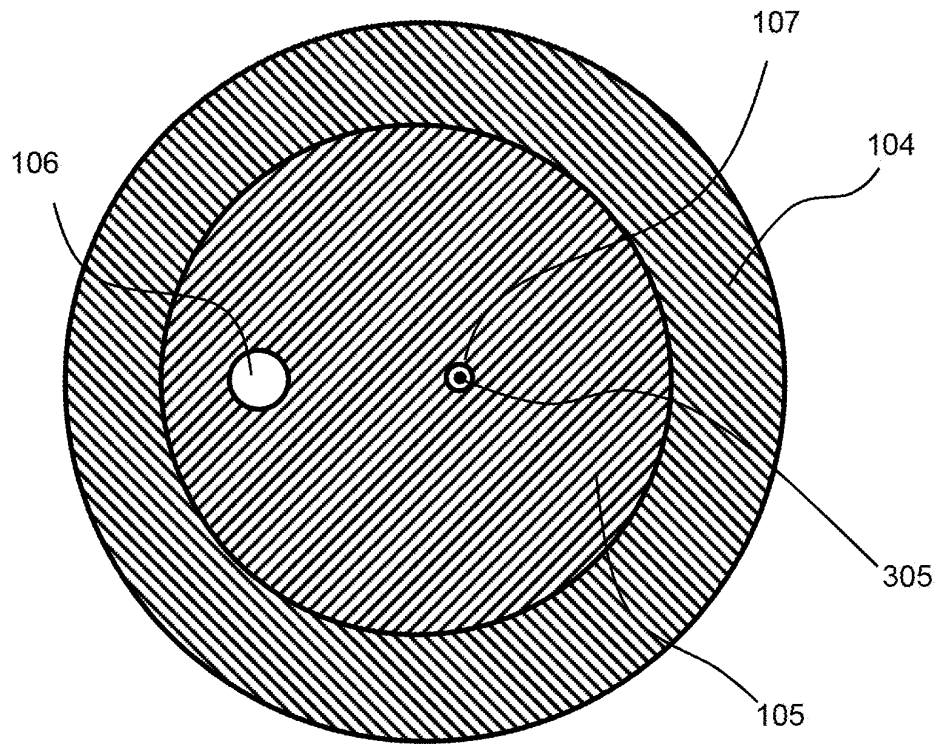

FIG. 3

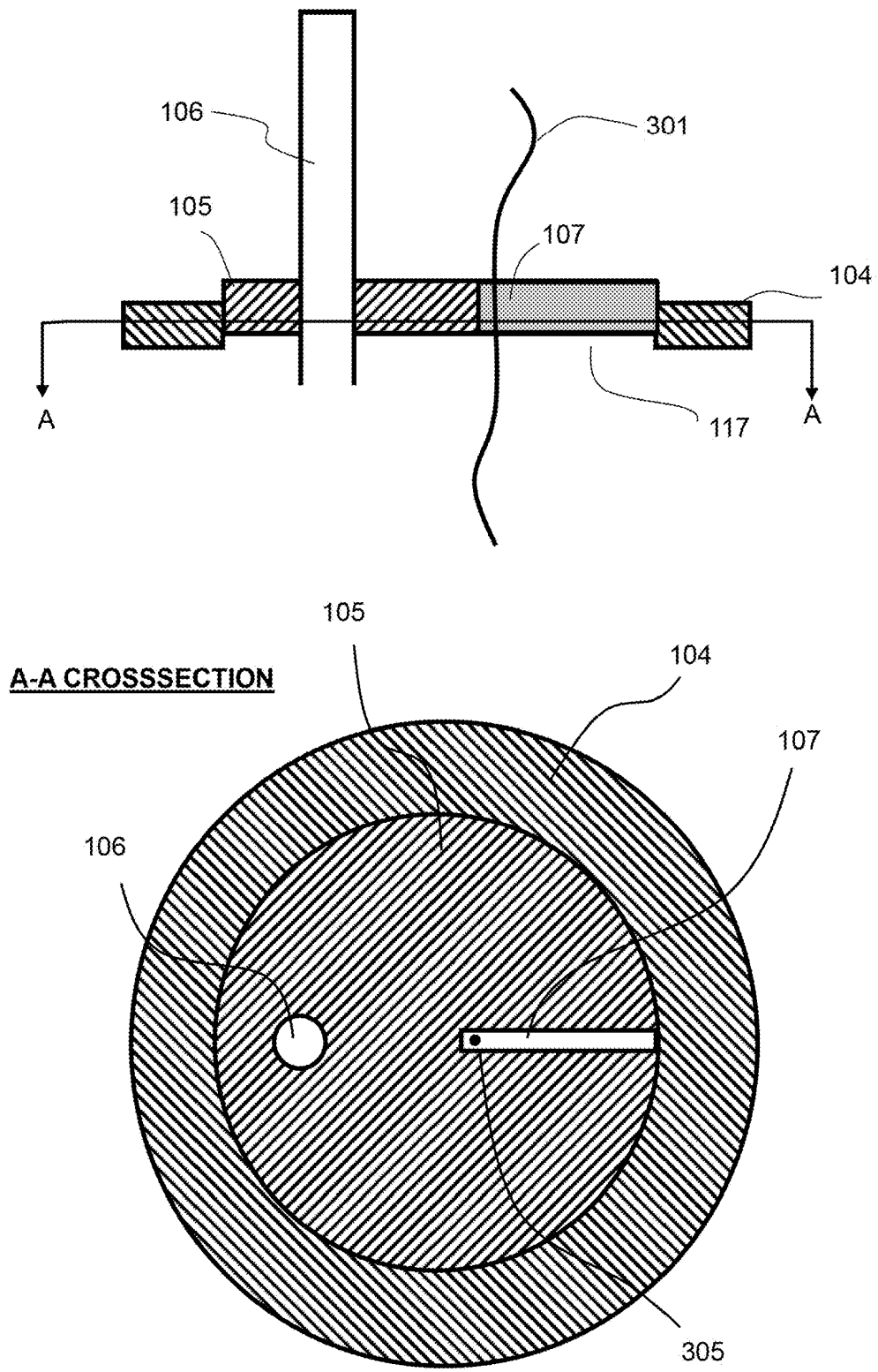

FIG. 4

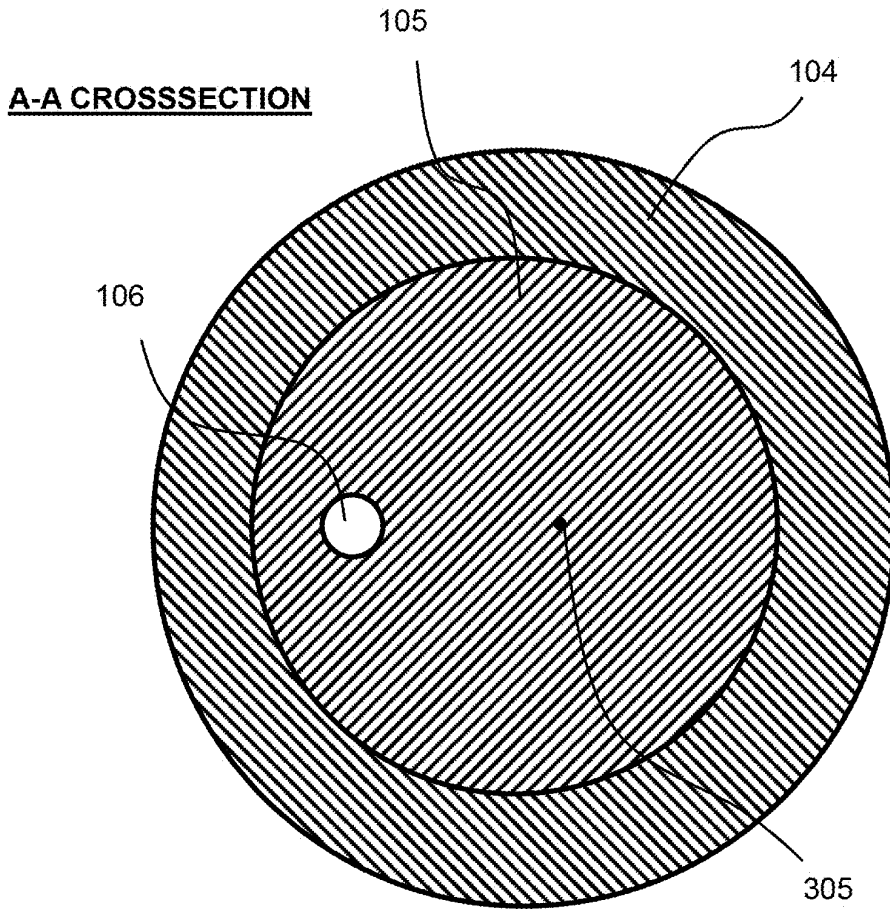
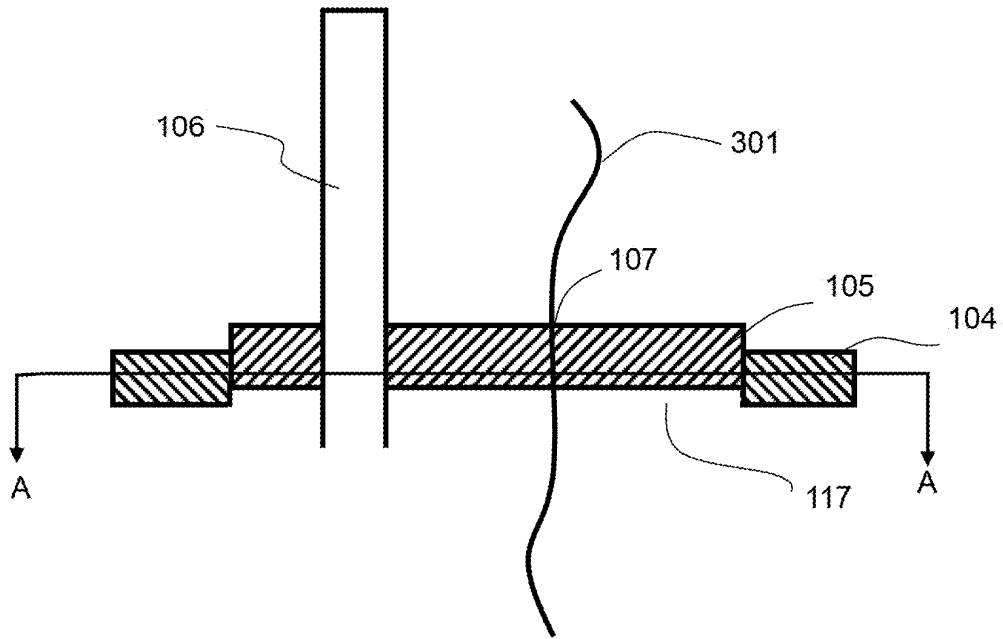
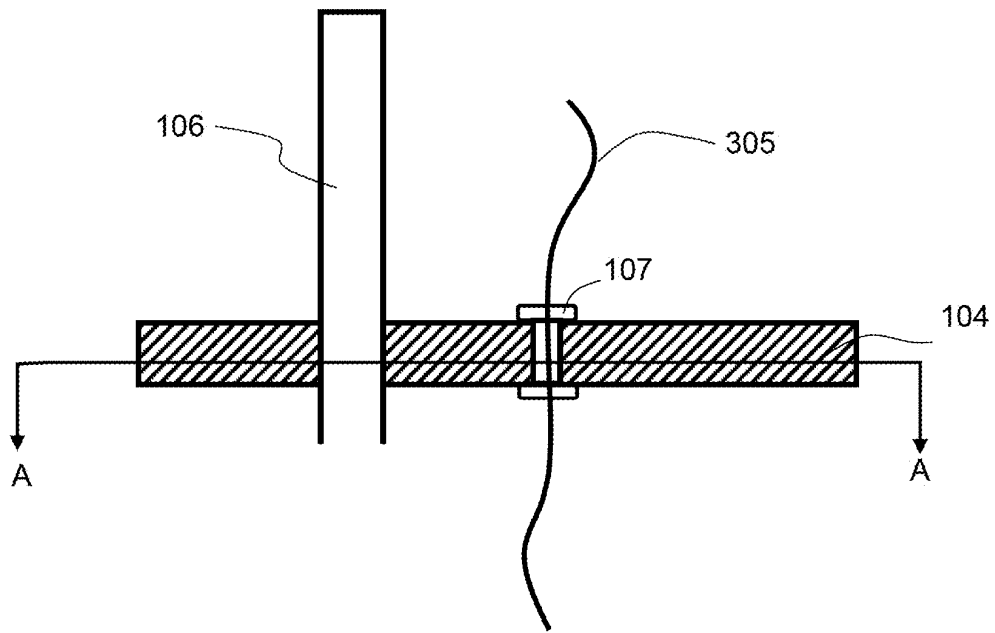

FIG. 5



A-A CROSSSECTION

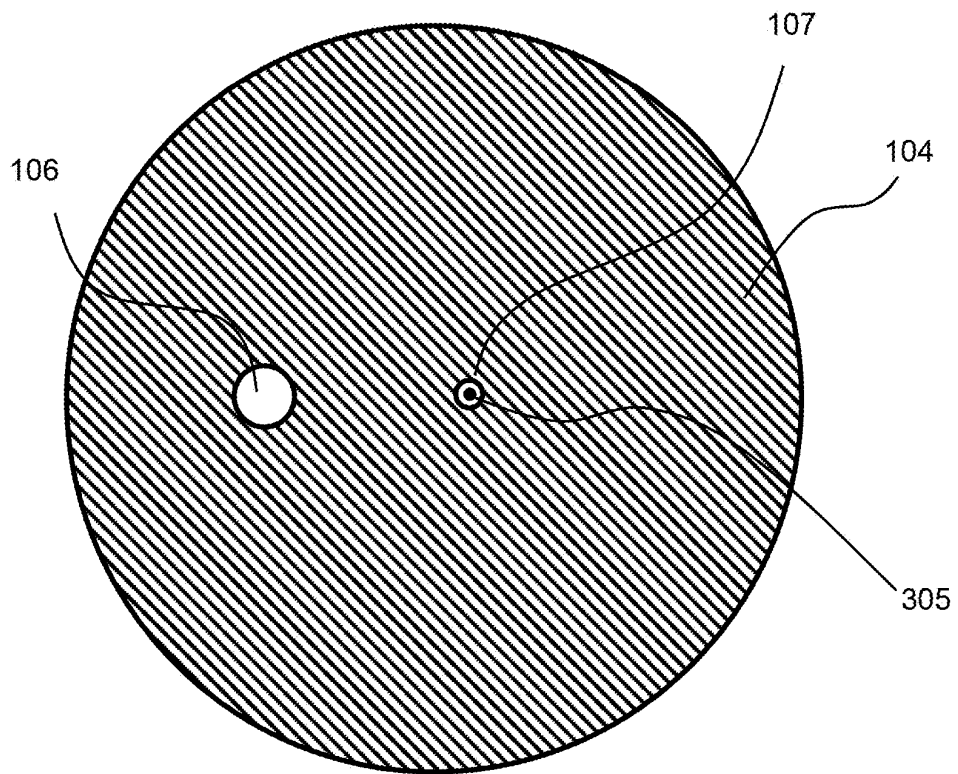
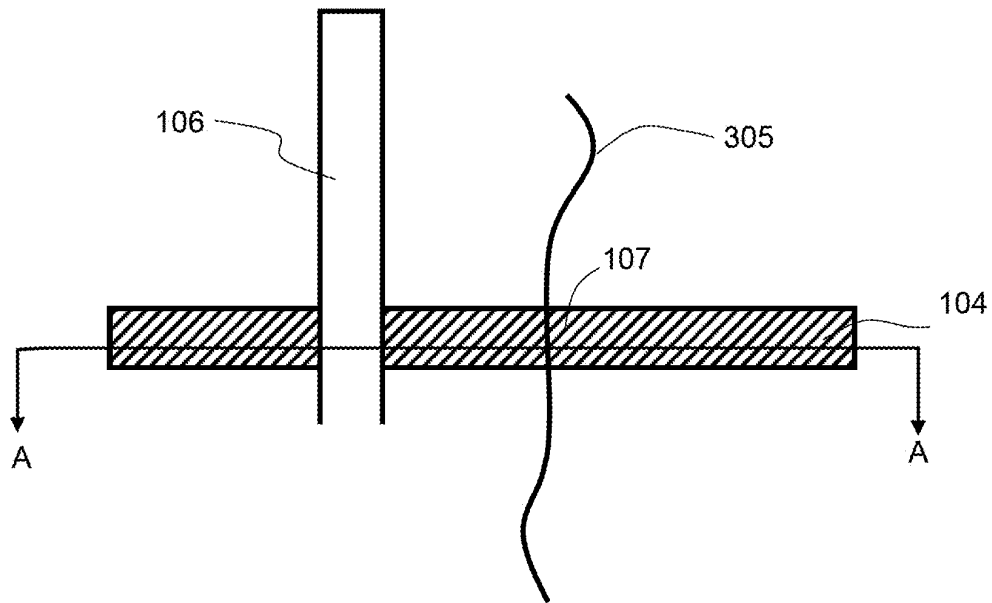

FIG. 6



A-A CROSSSECTION

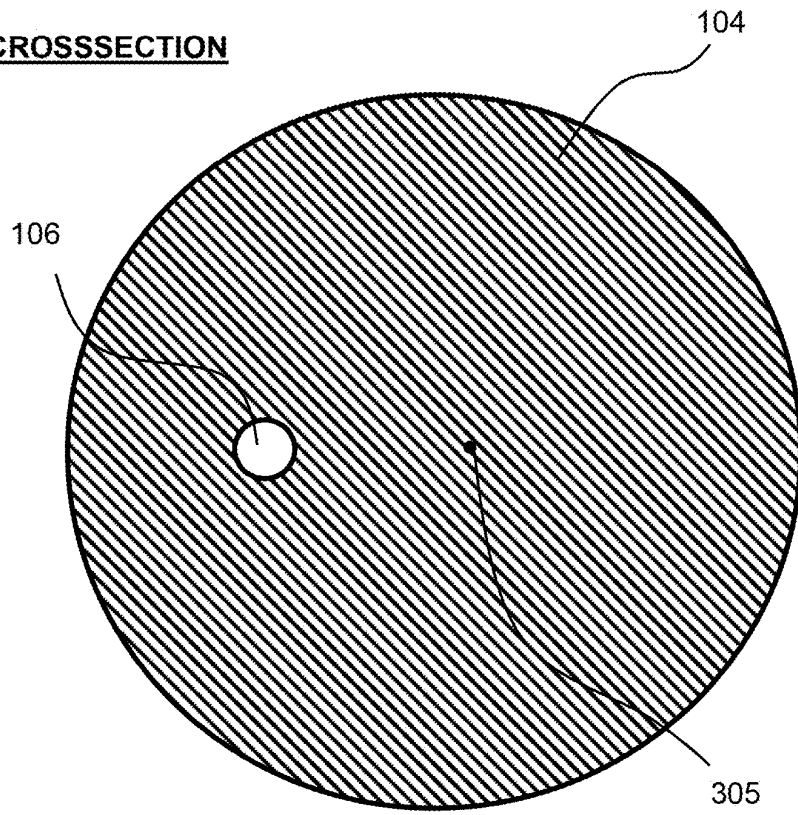

FIG. 7

100

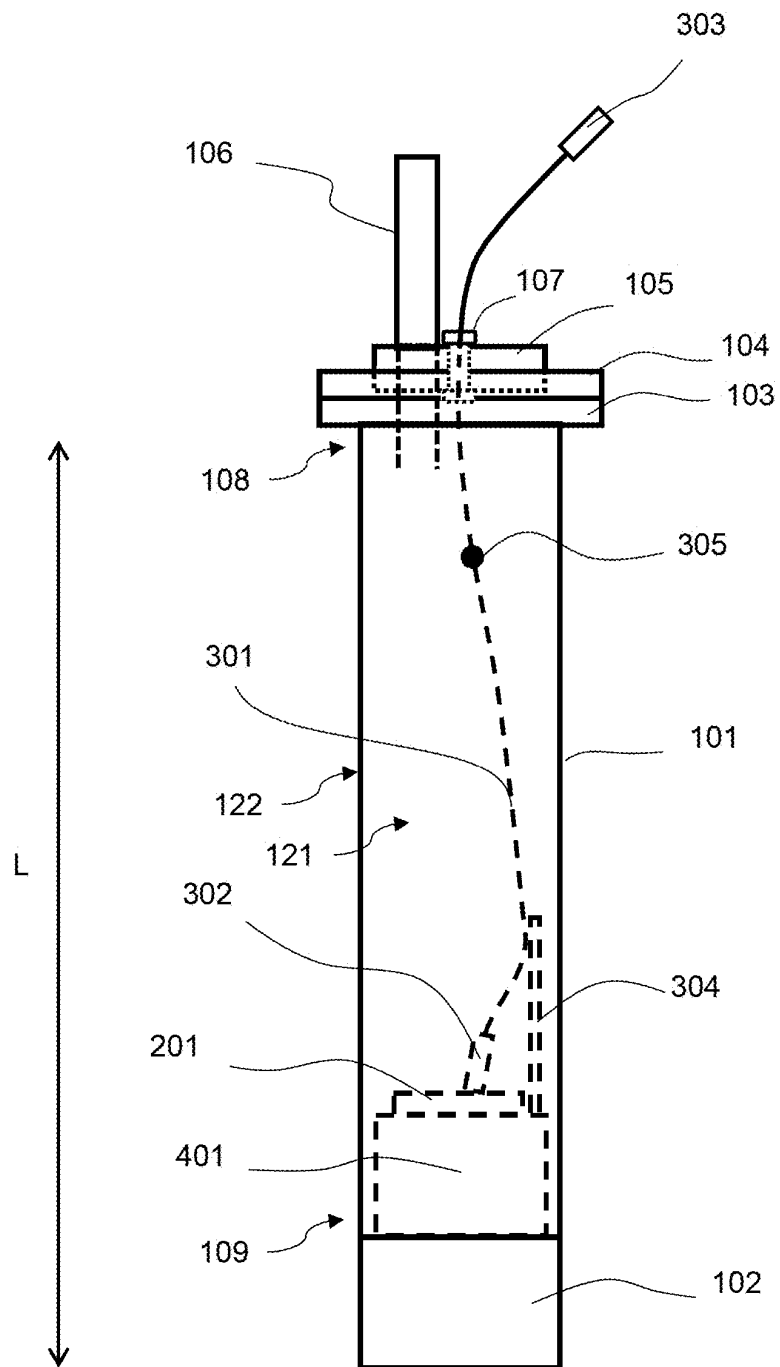

FIG. 8

100

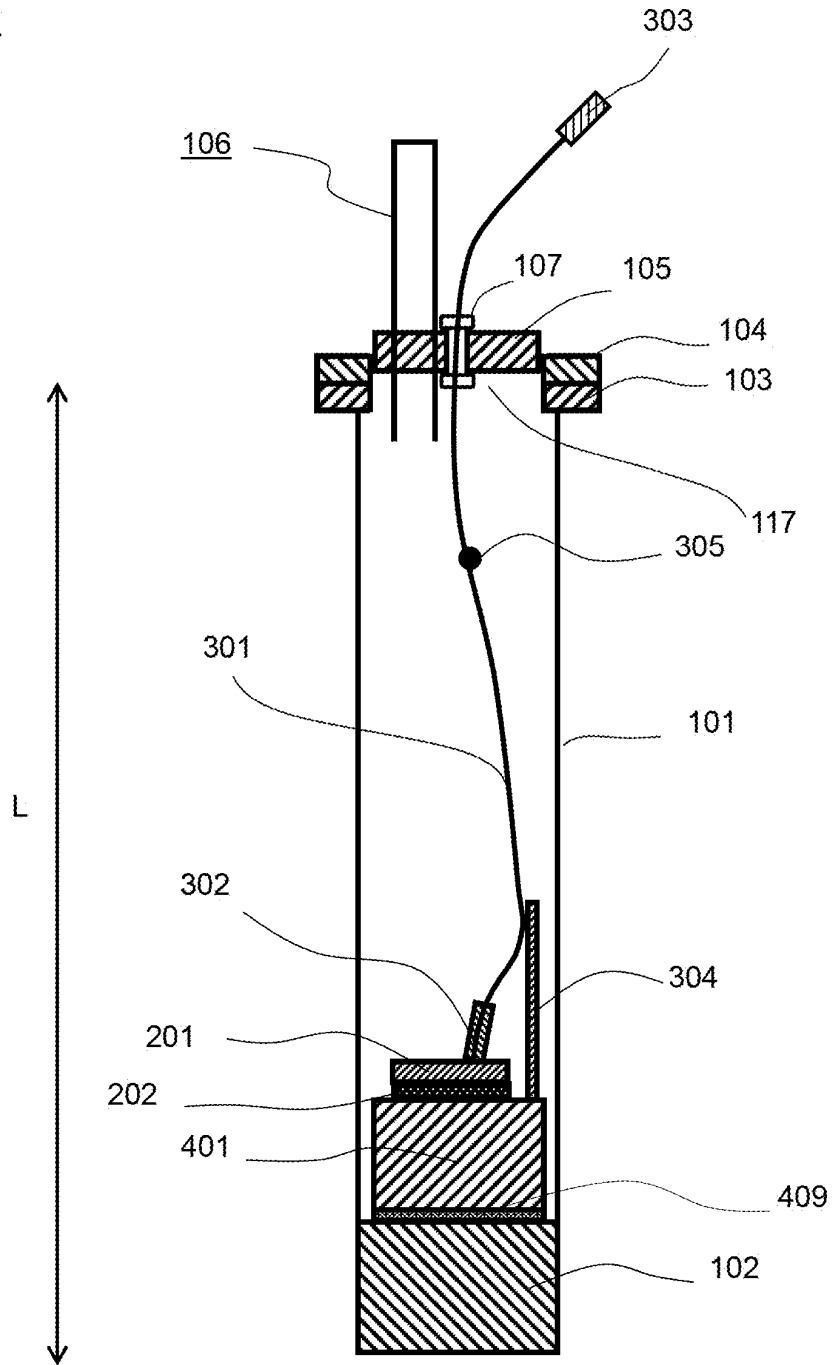

FIG. 9

100

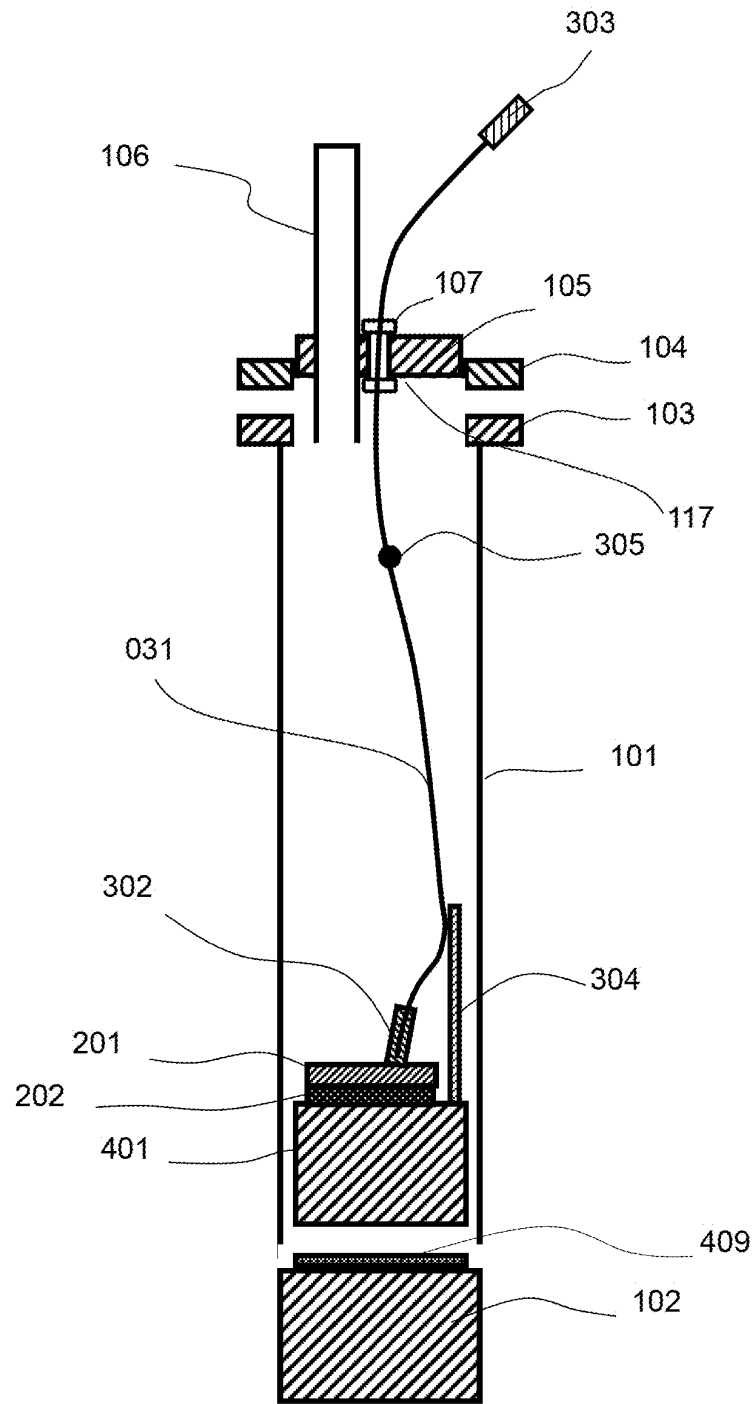

FIG. 10

100

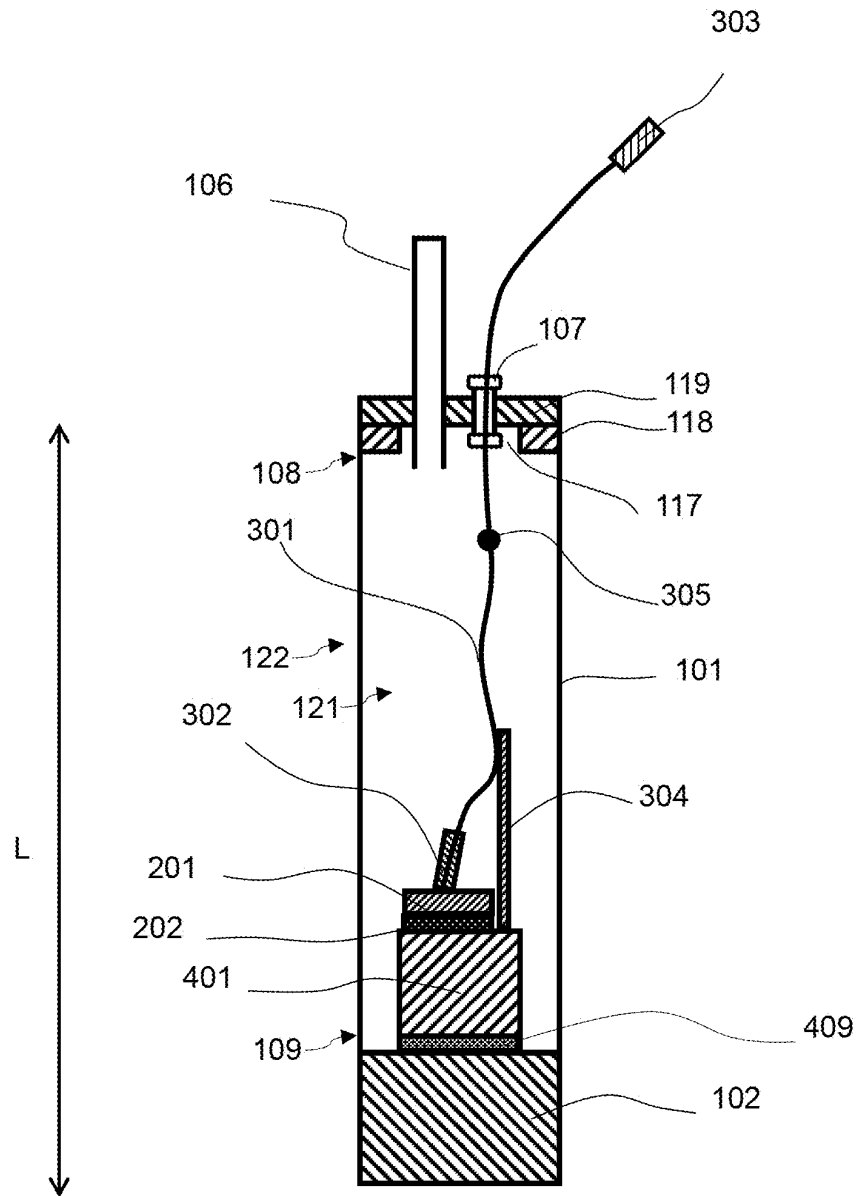

FIG. 11

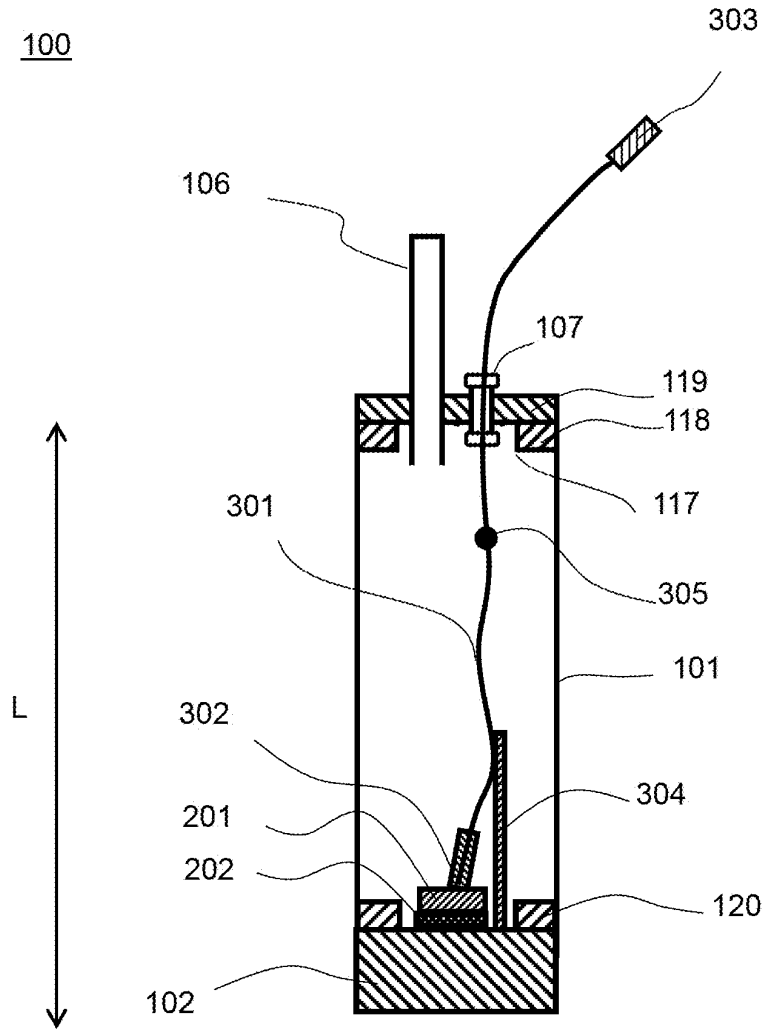

FIG. 12

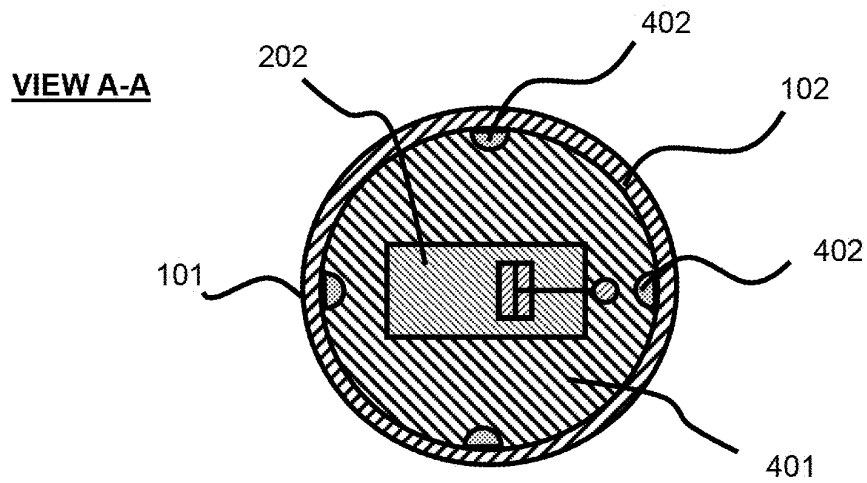
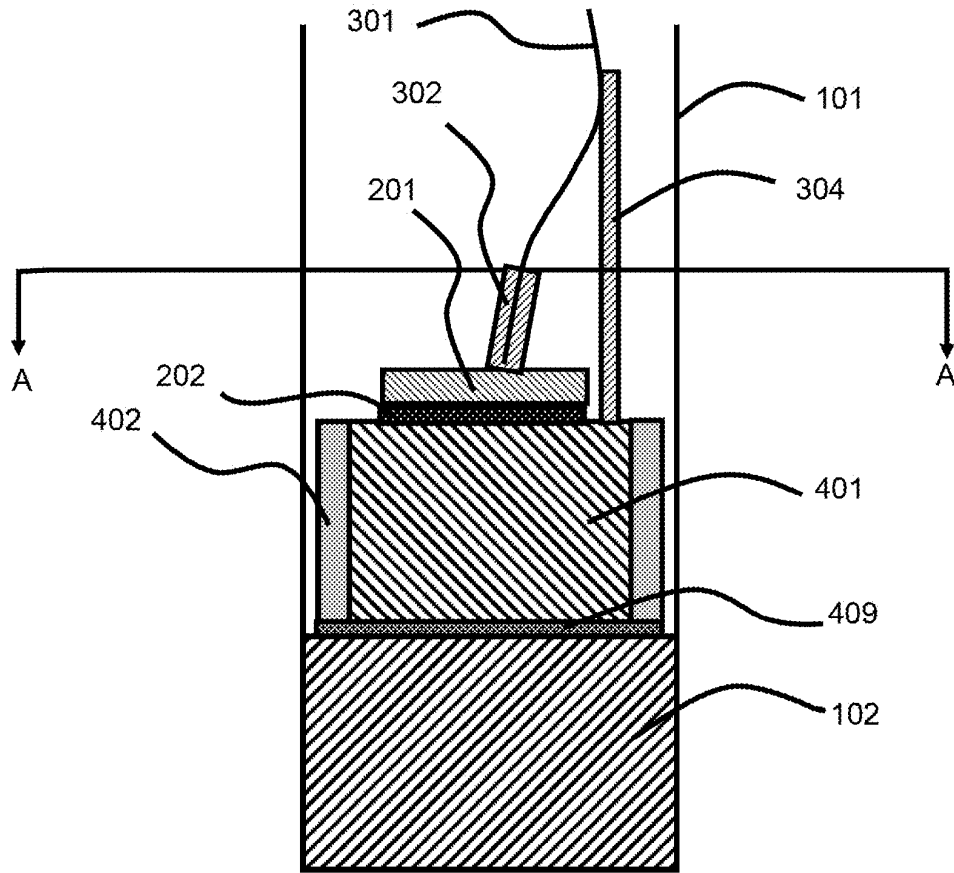

FIG. 13

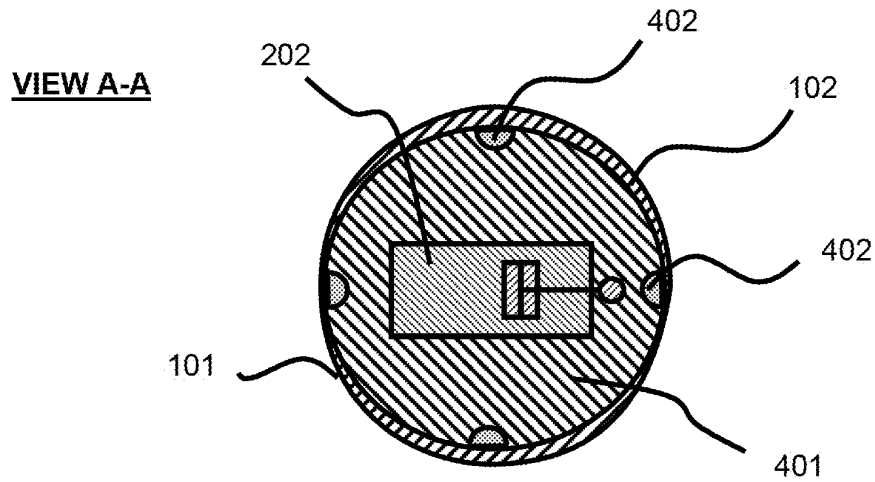
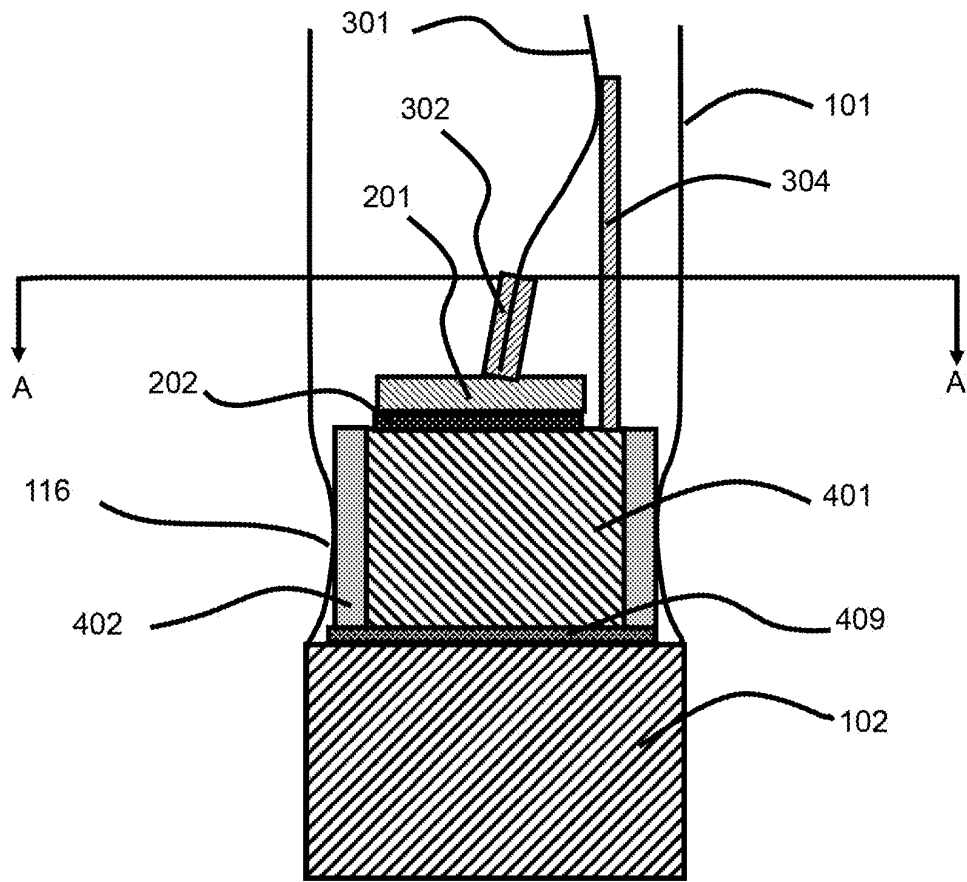

FIG. 14

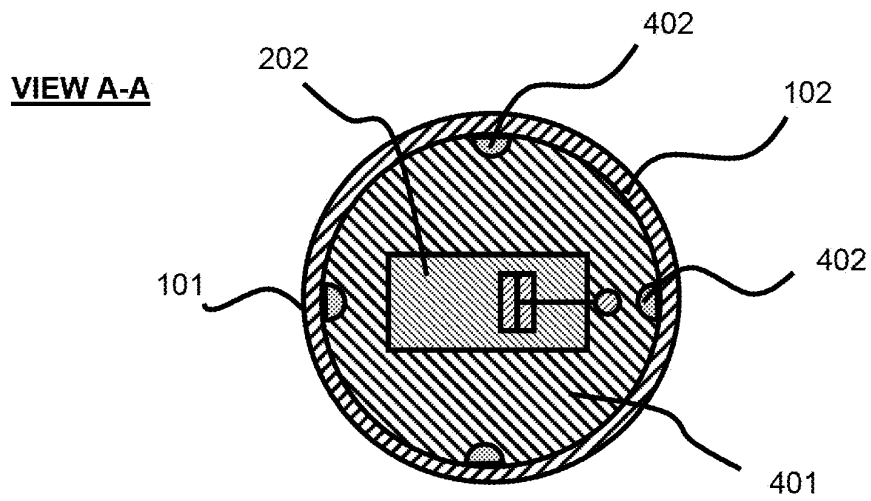
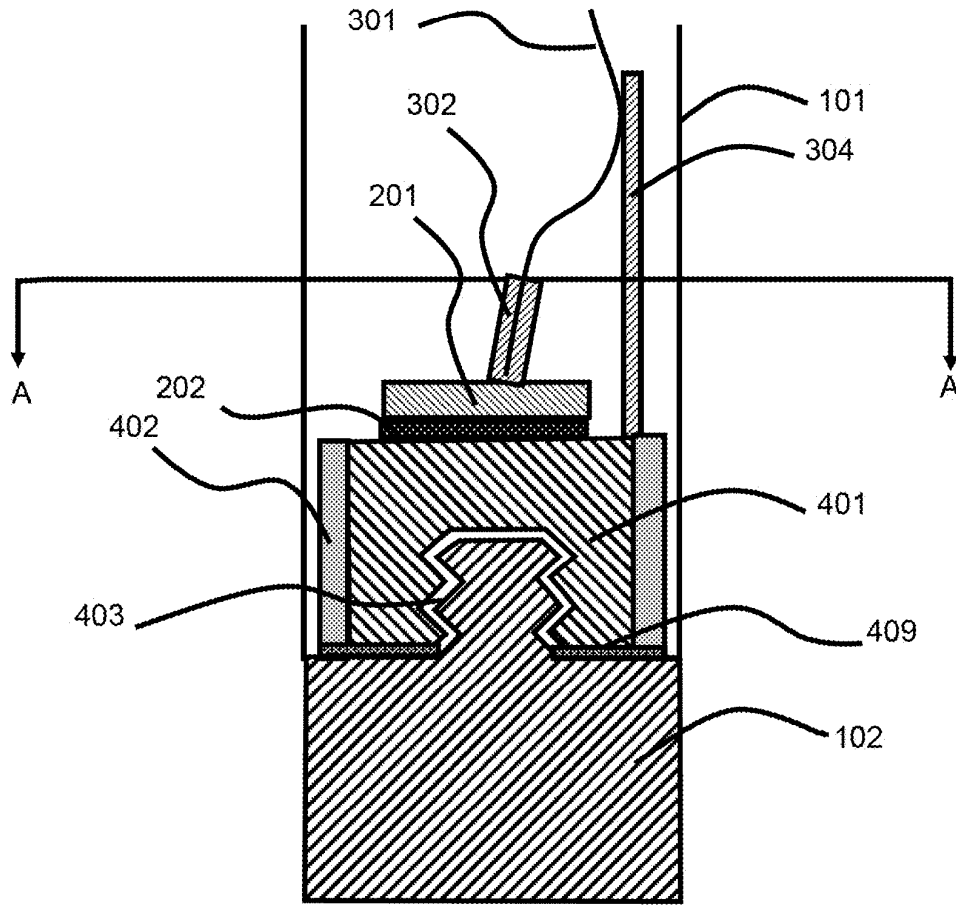

FIG. 15

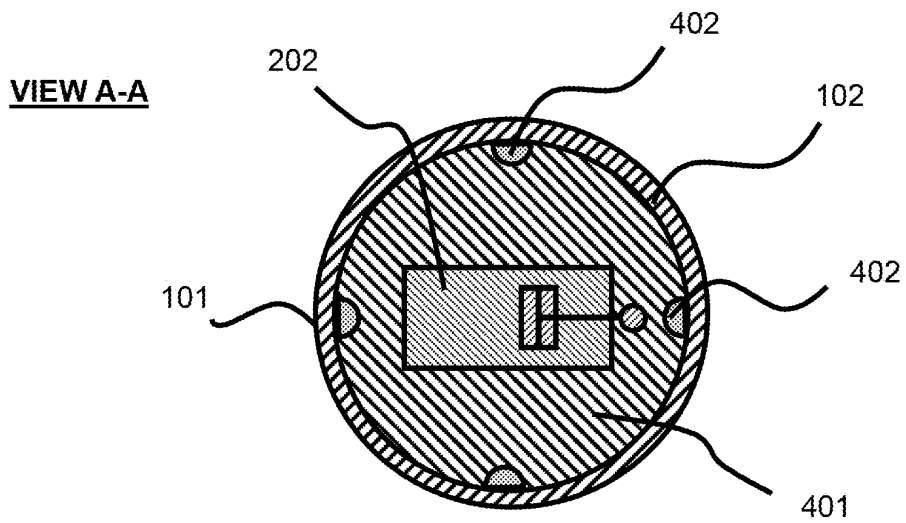
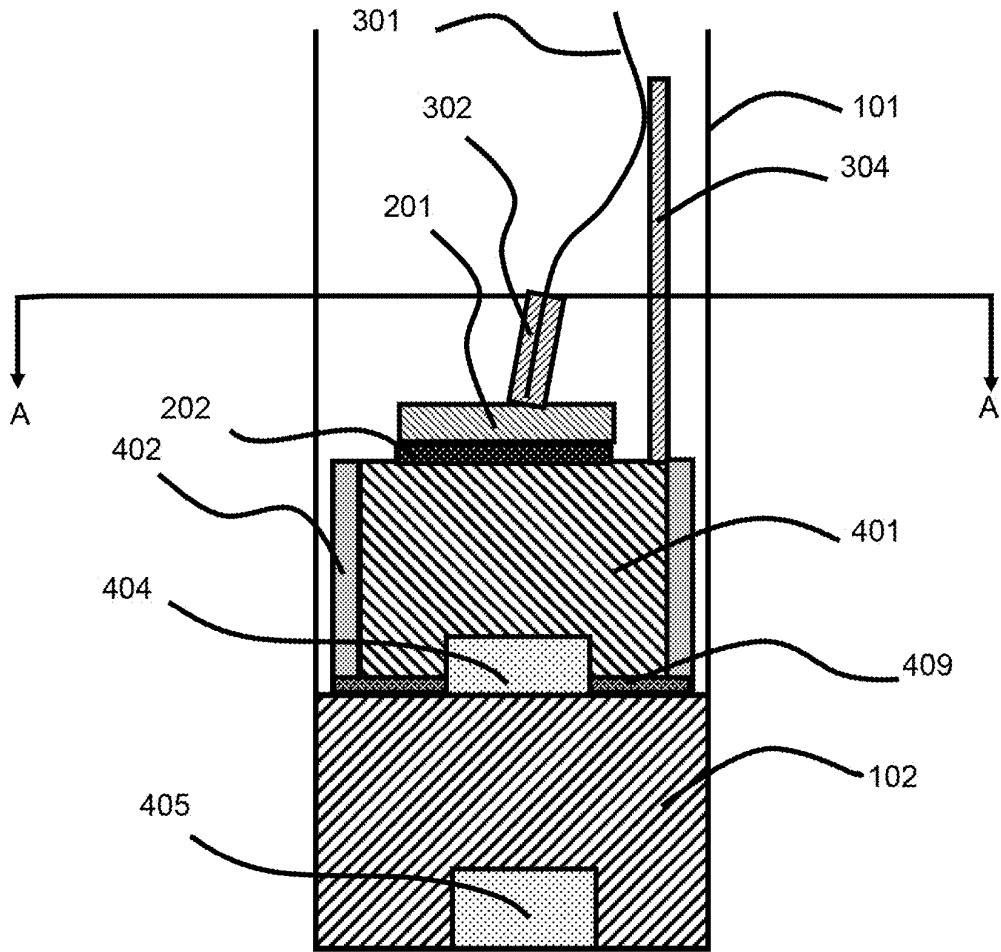

FIG. 16

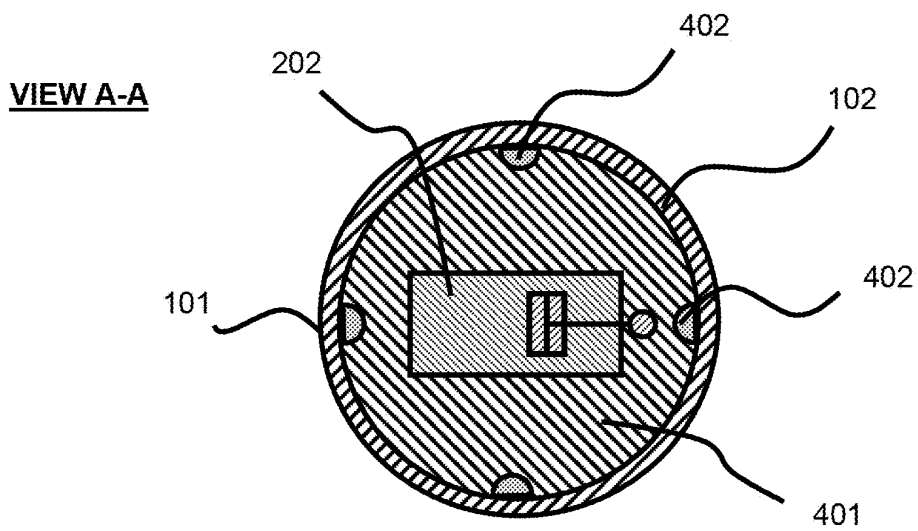
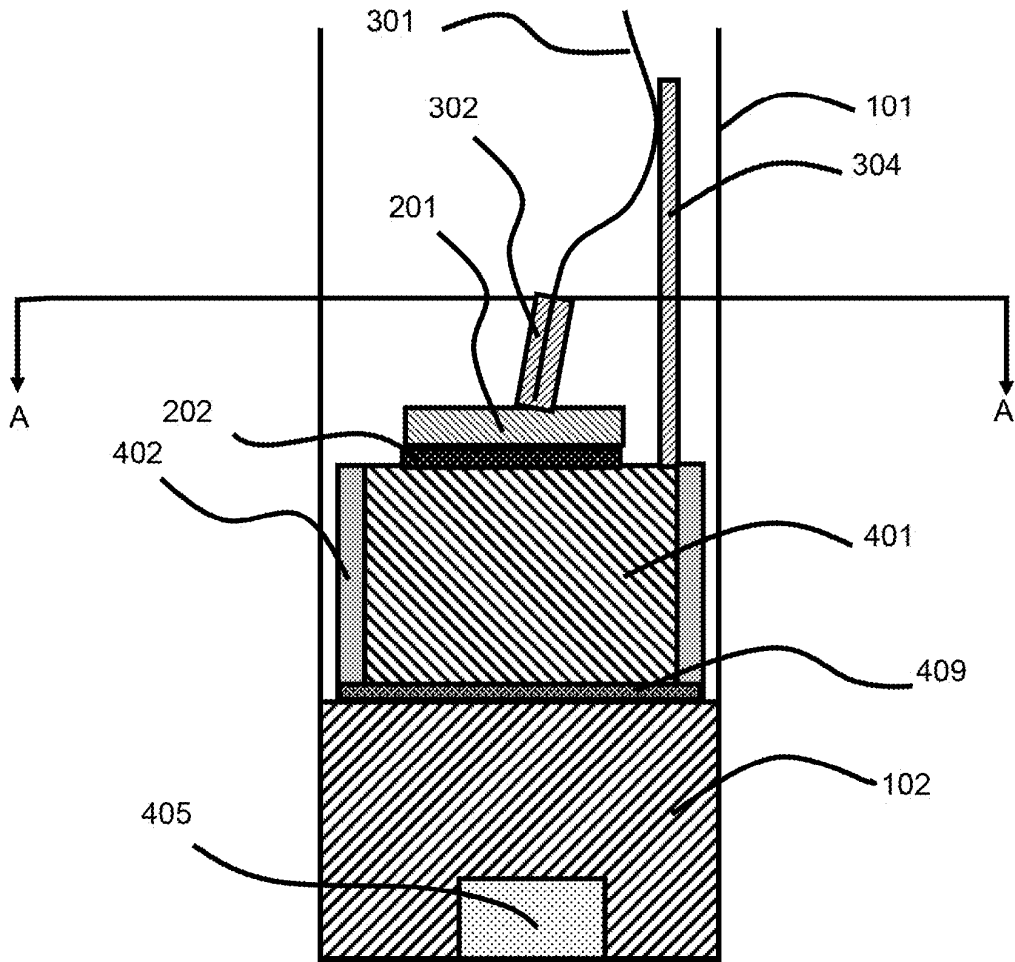

FIG. 17

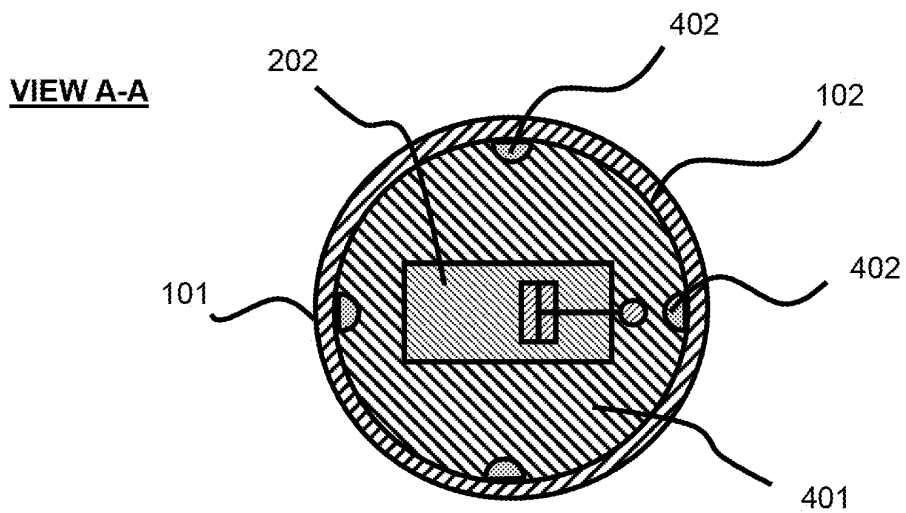
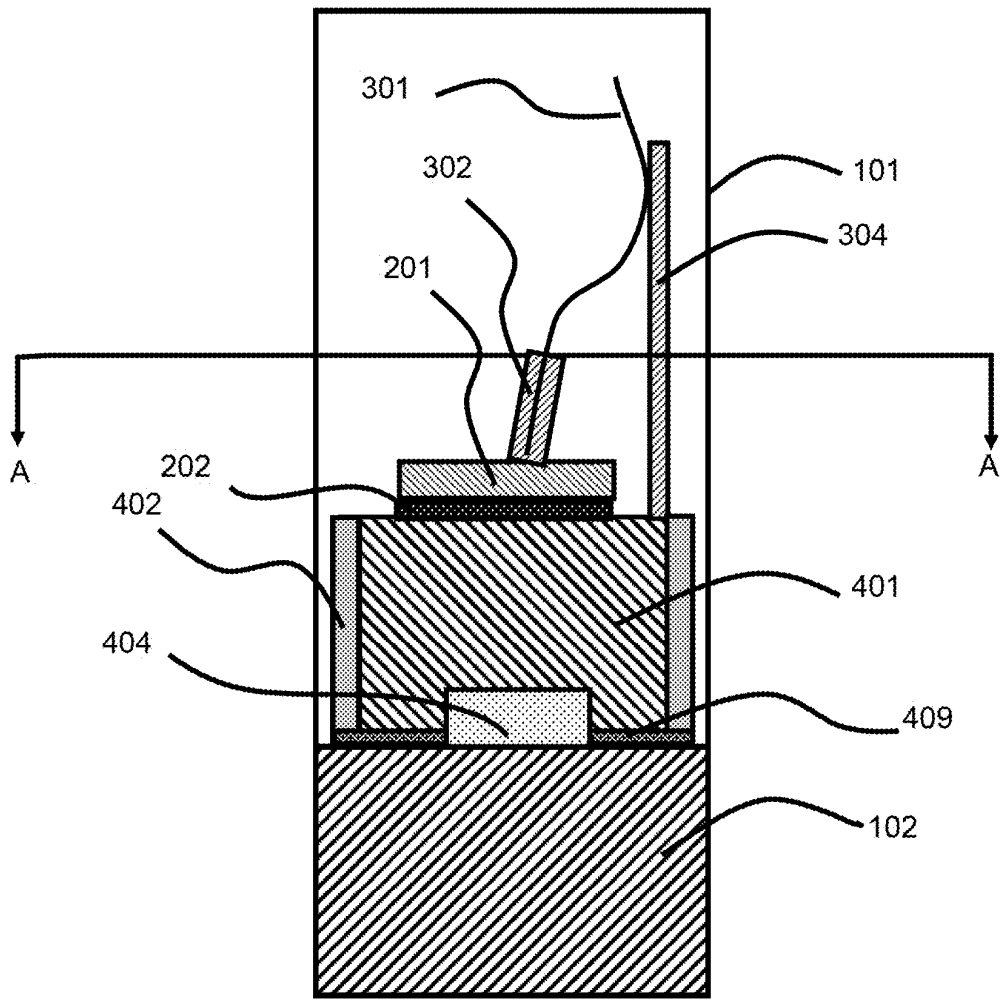

FIG. 18

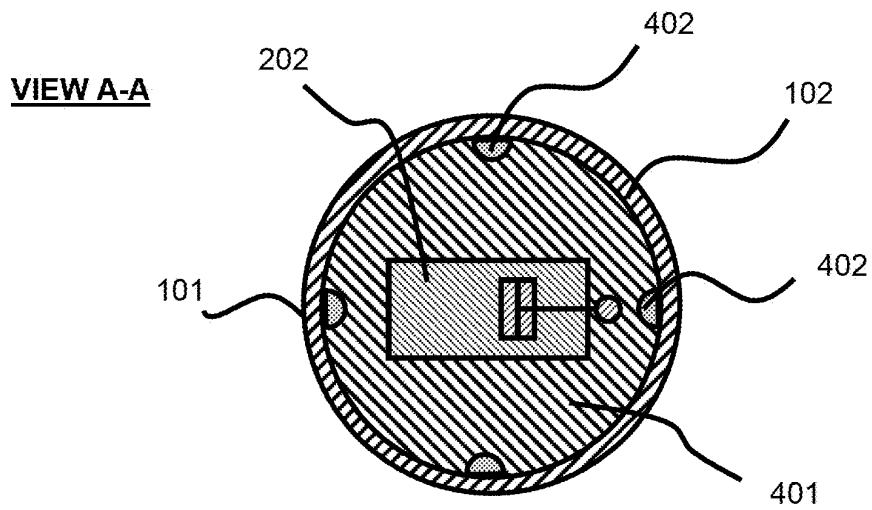
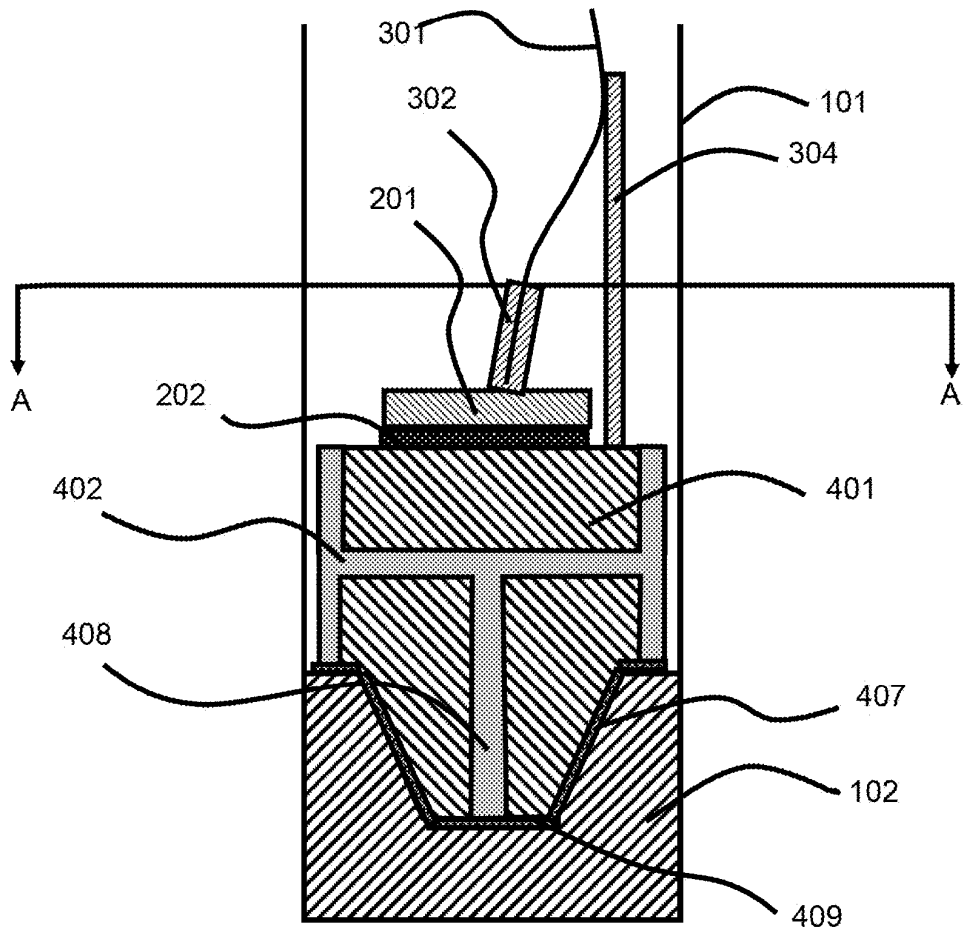

FIG. 19

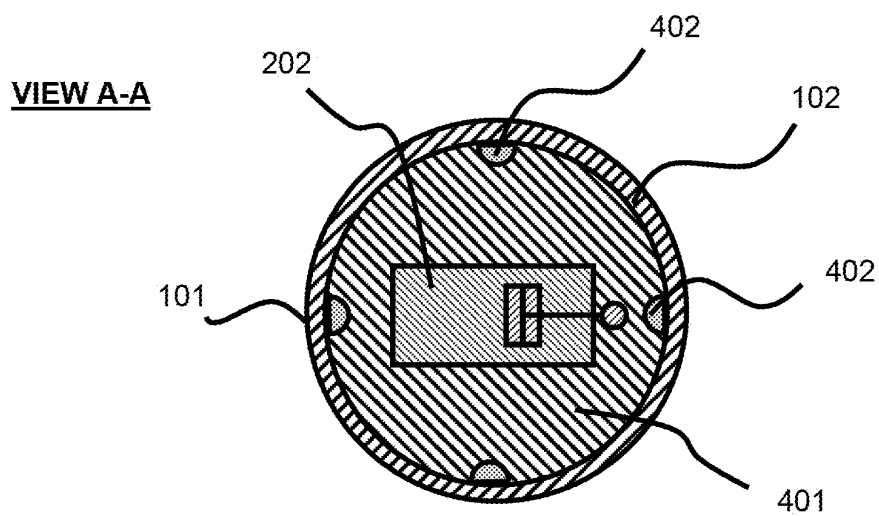
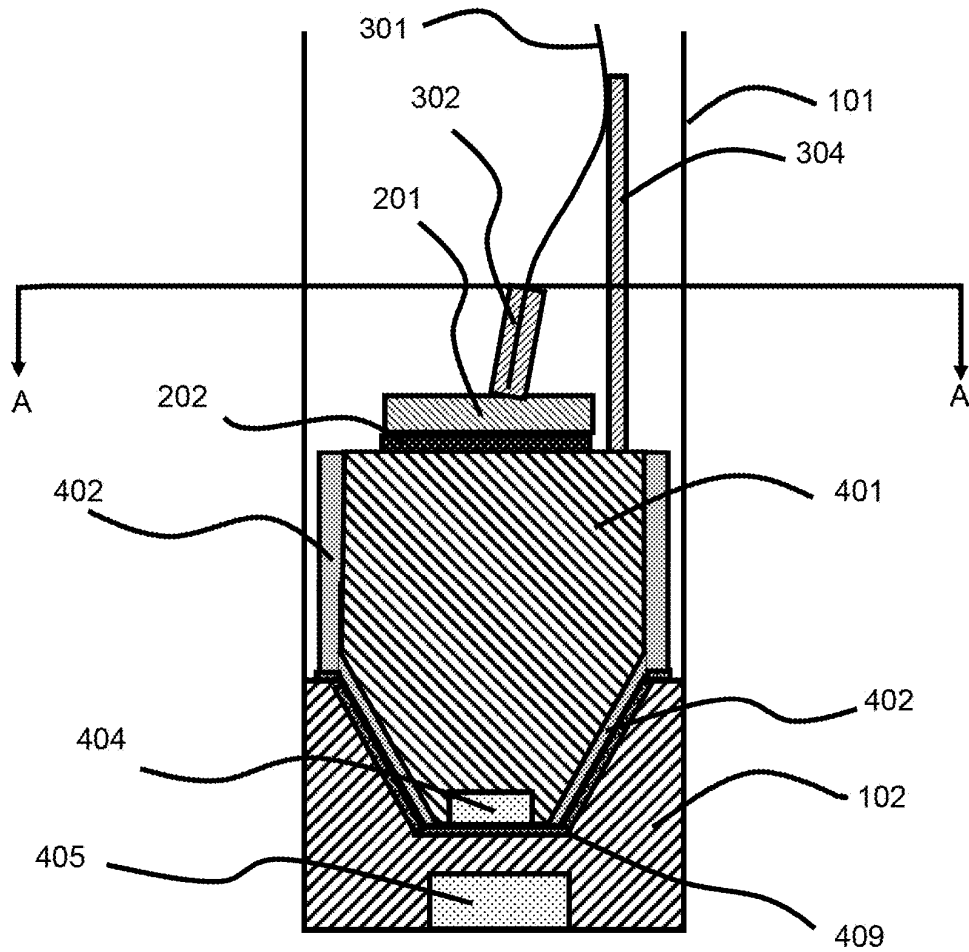

FIG. 20

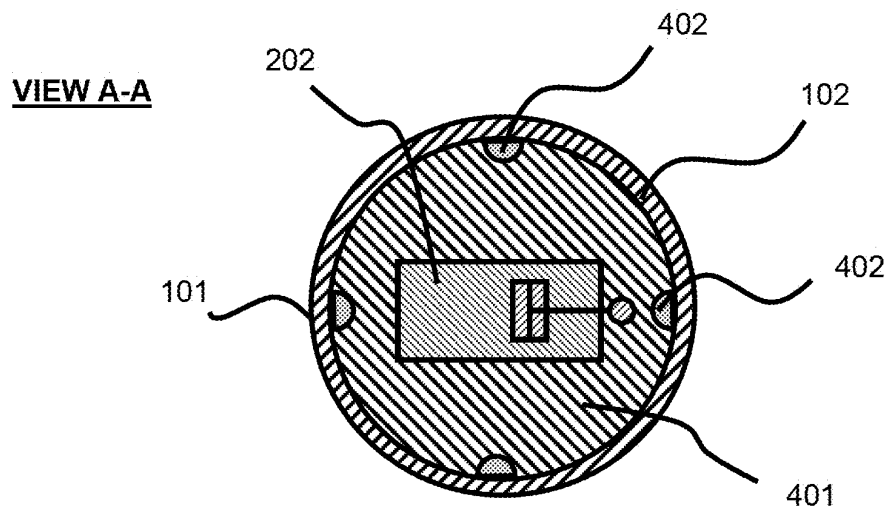
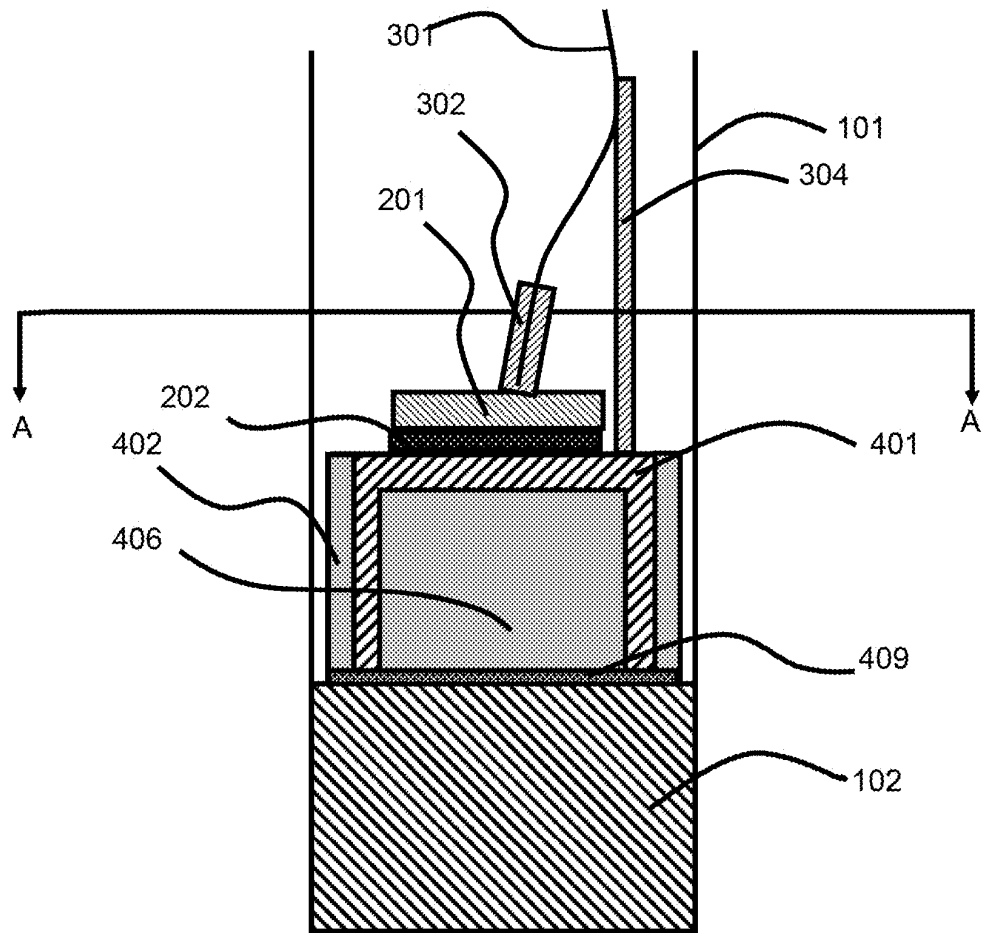

FIG. 21

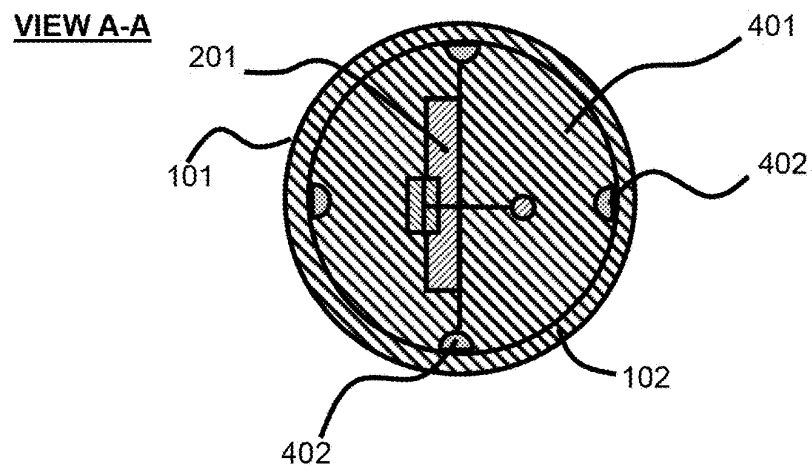
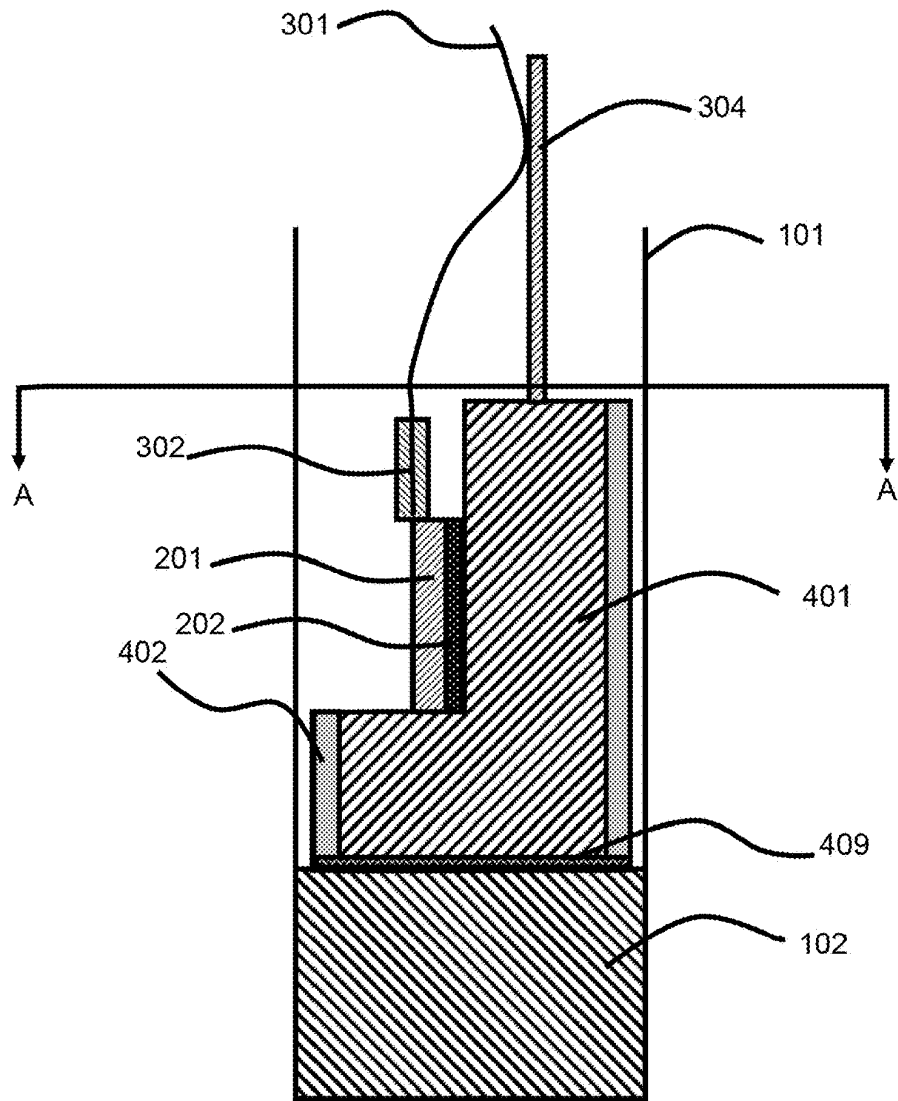
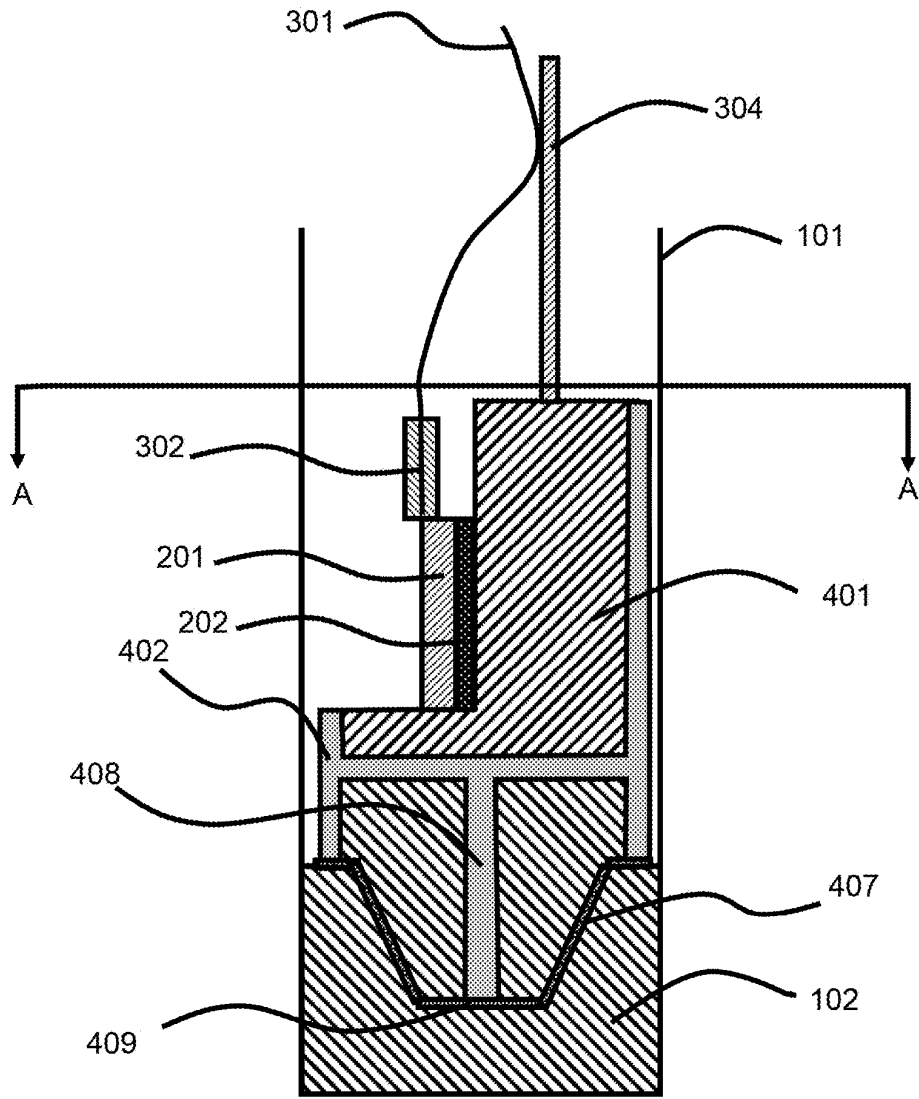

FIG. 22



VIEW A-A

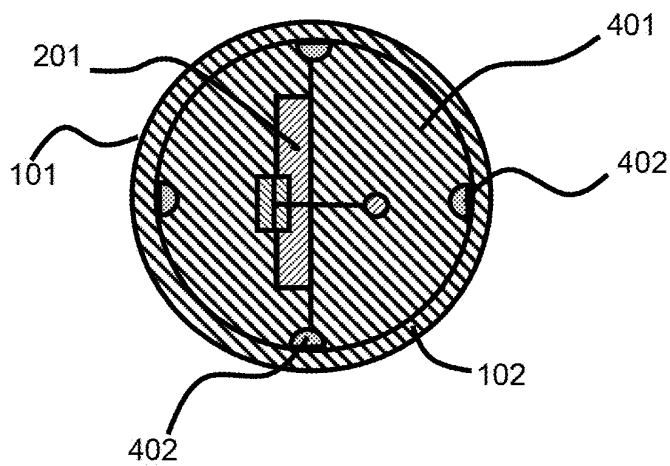
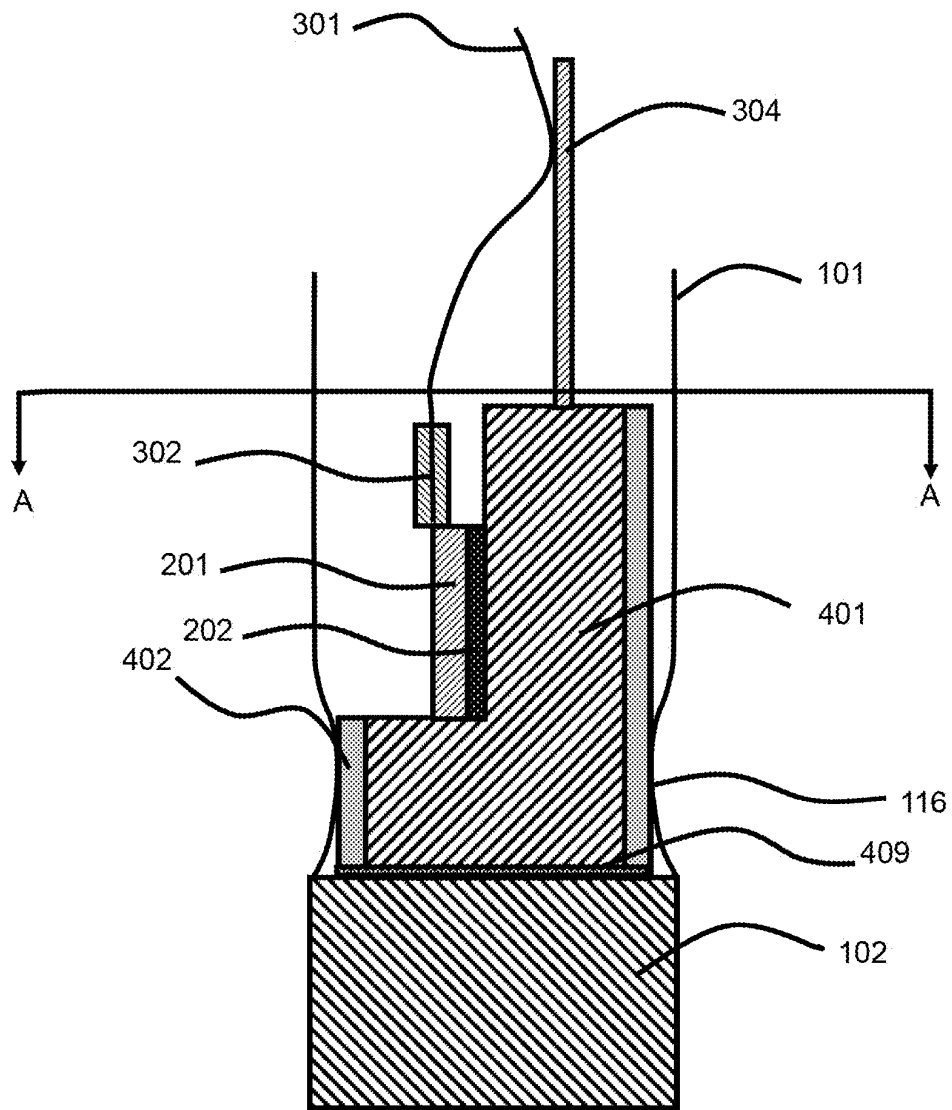

FIG. 23



VIEW A-A

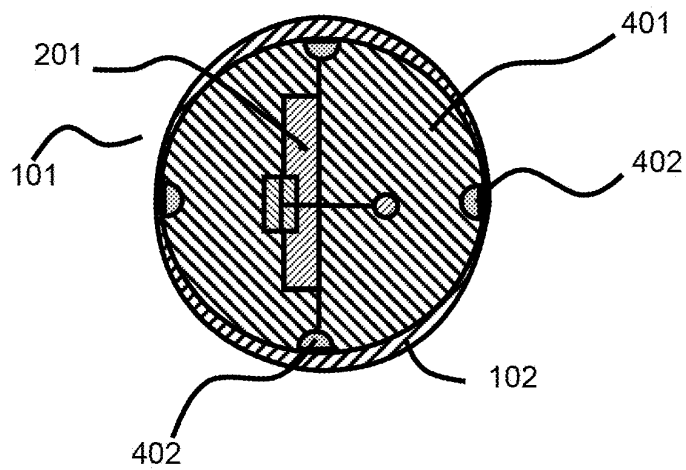
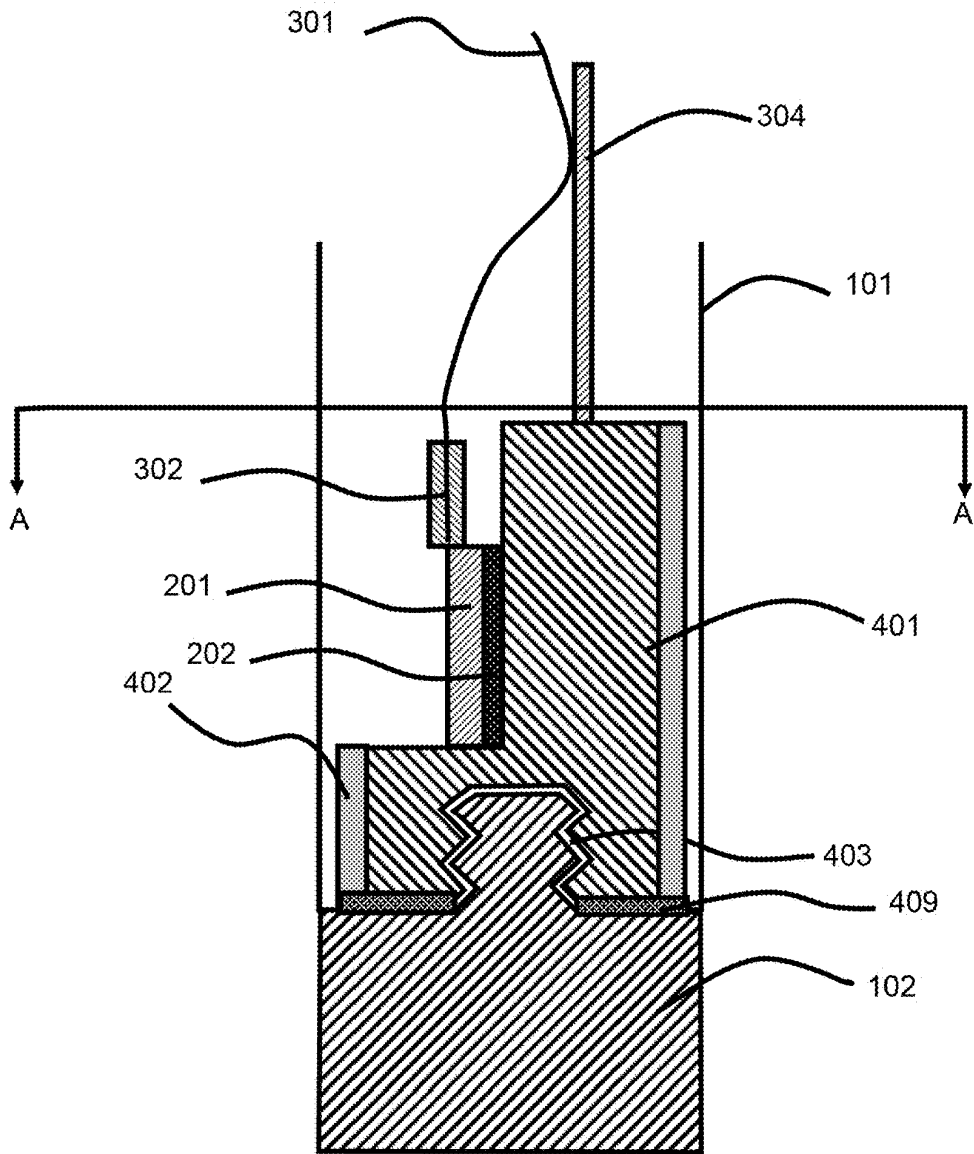

FIG. 24



VIEW A-A

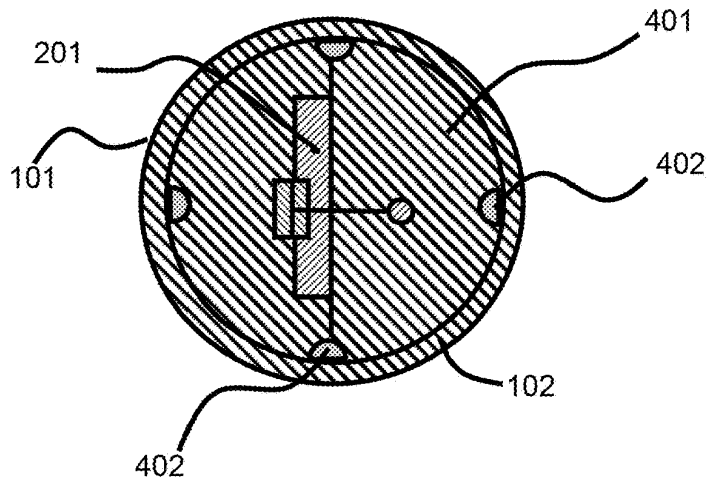
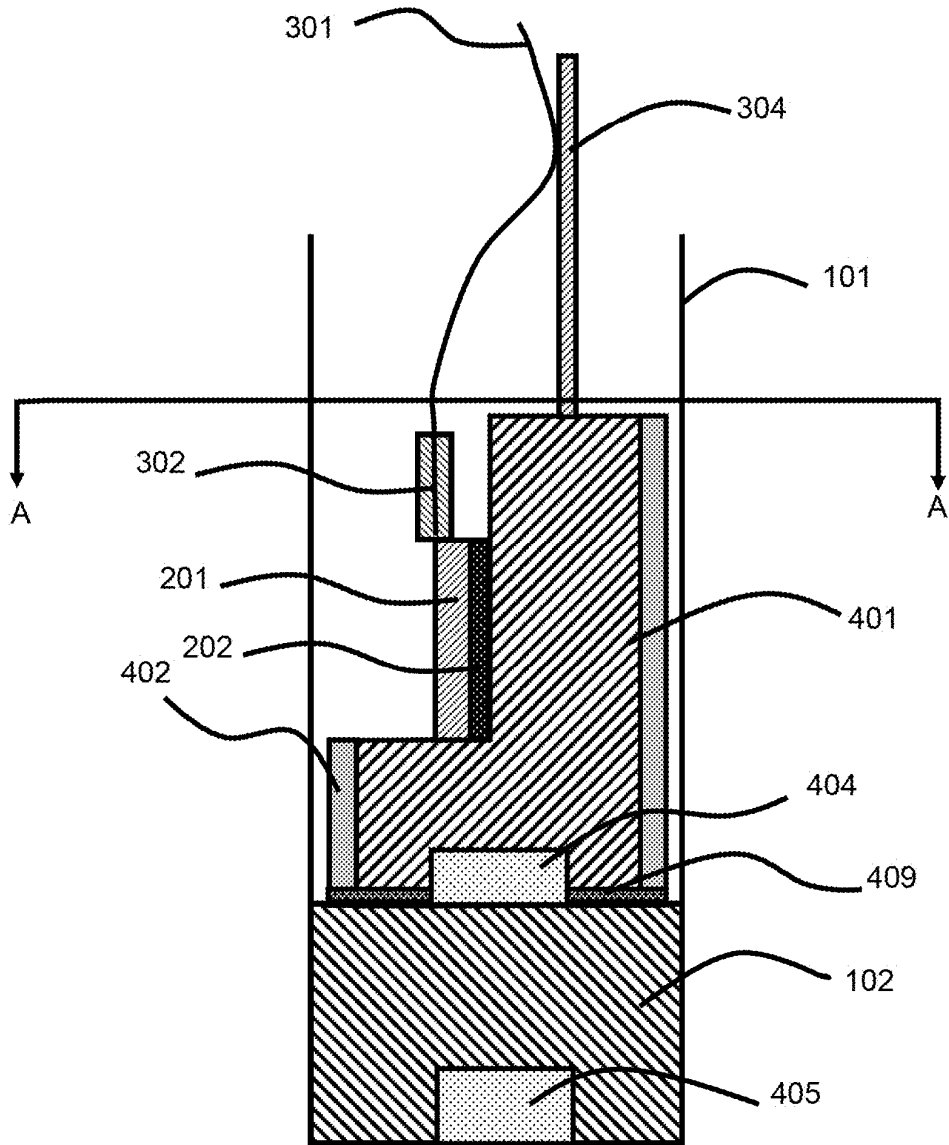

FIG. 25



VIEW A-A

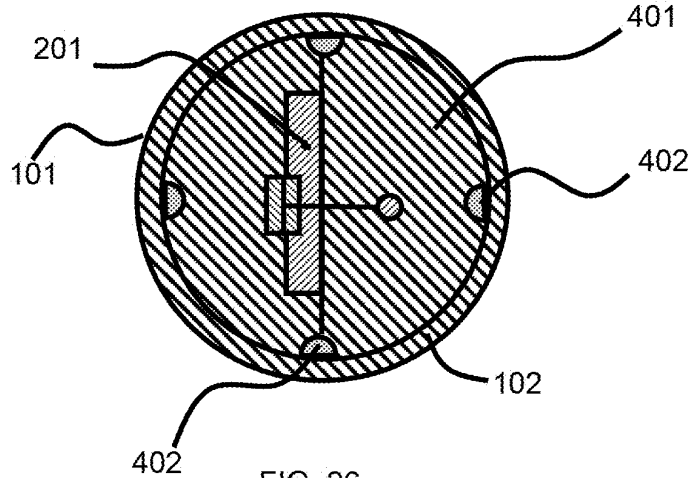

FIG. 26

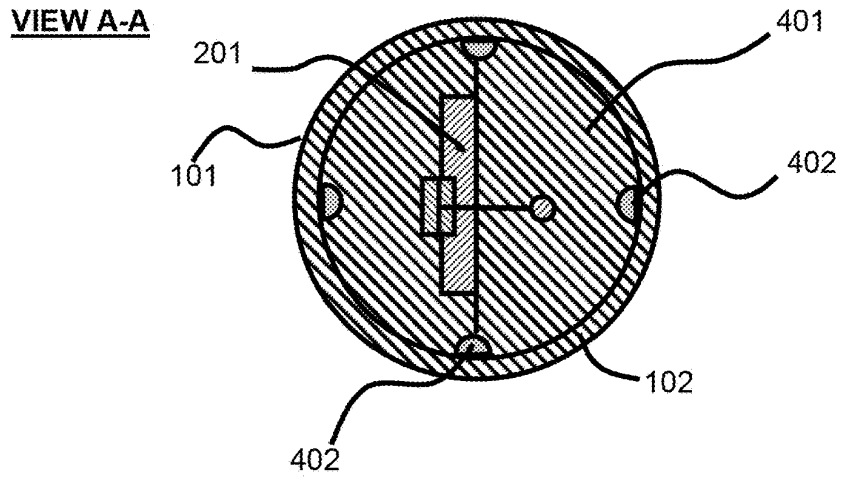
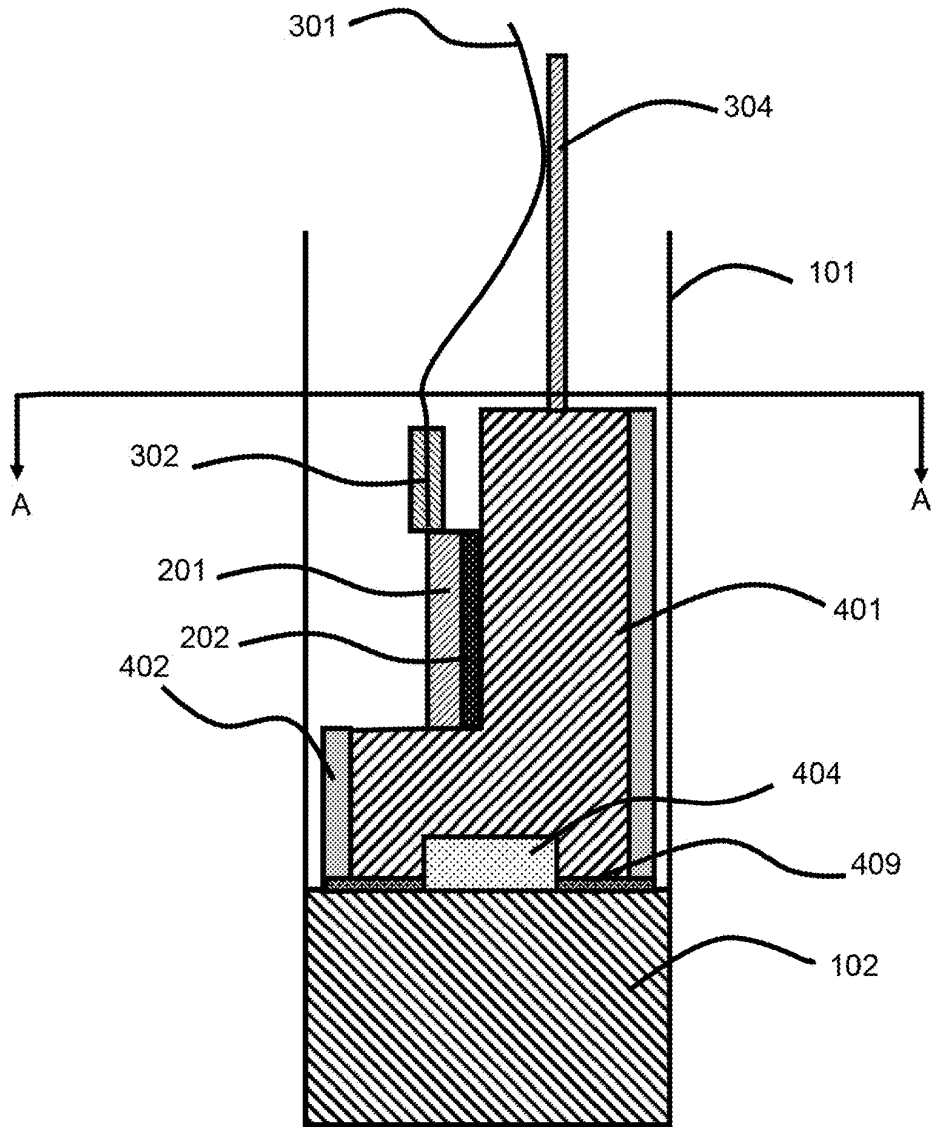
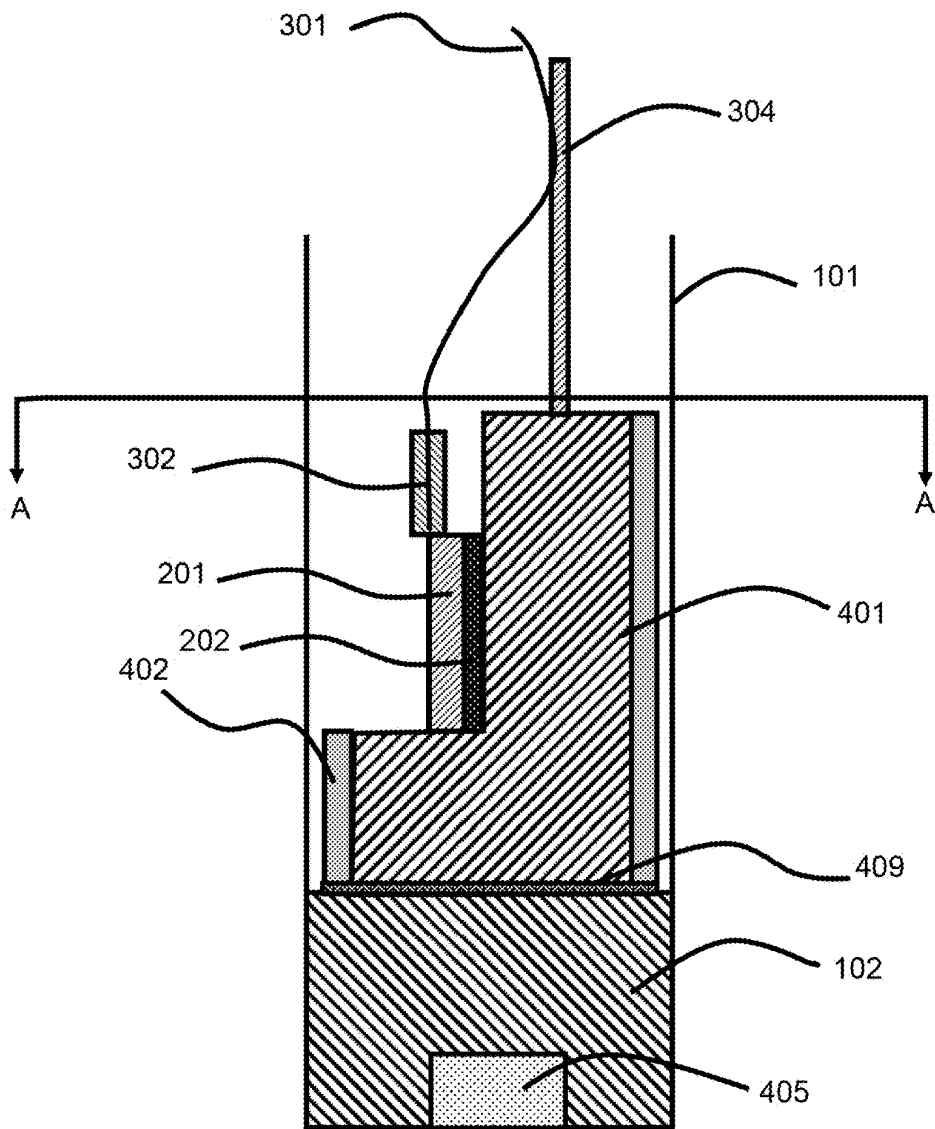

FIG. 27



VIEW A-A

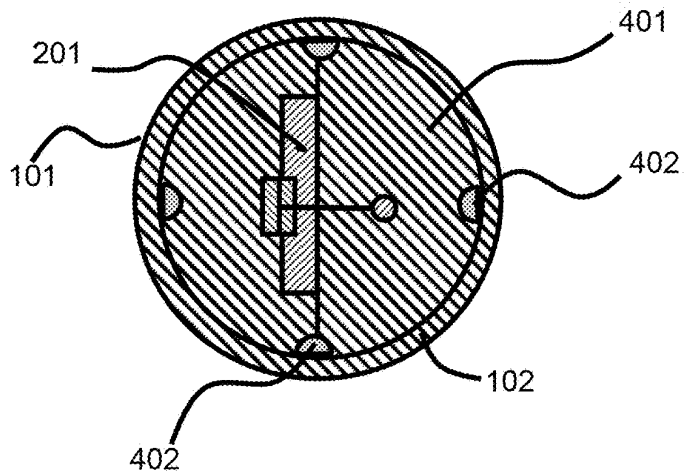
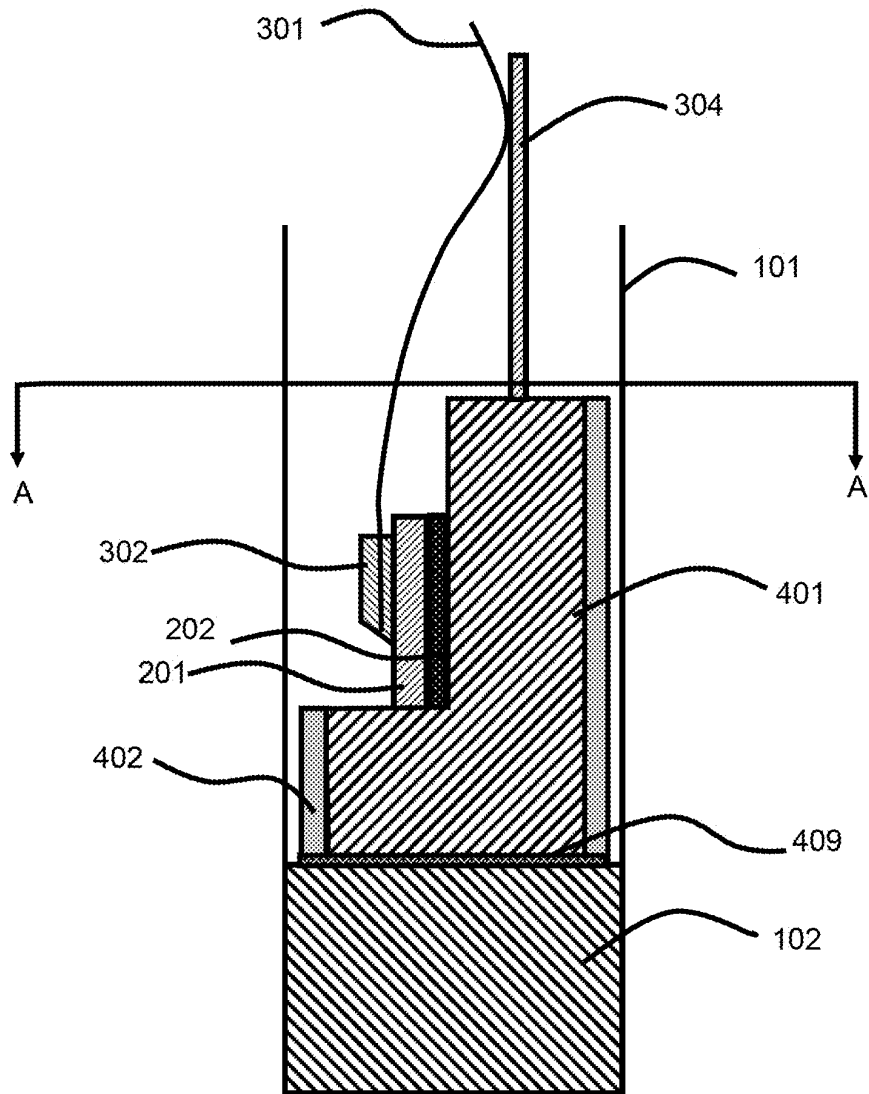

FIG. 28



VIEW A-A

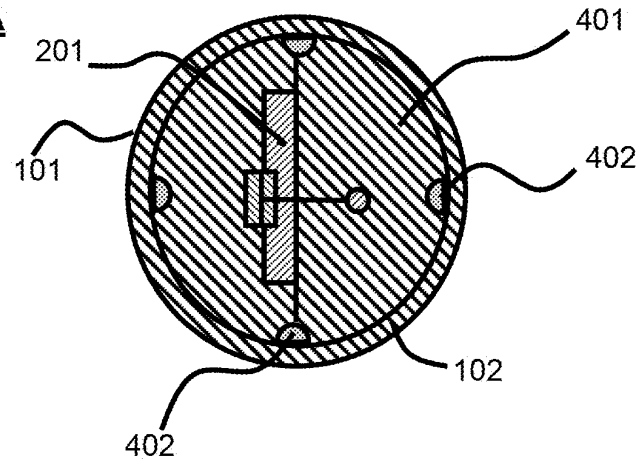
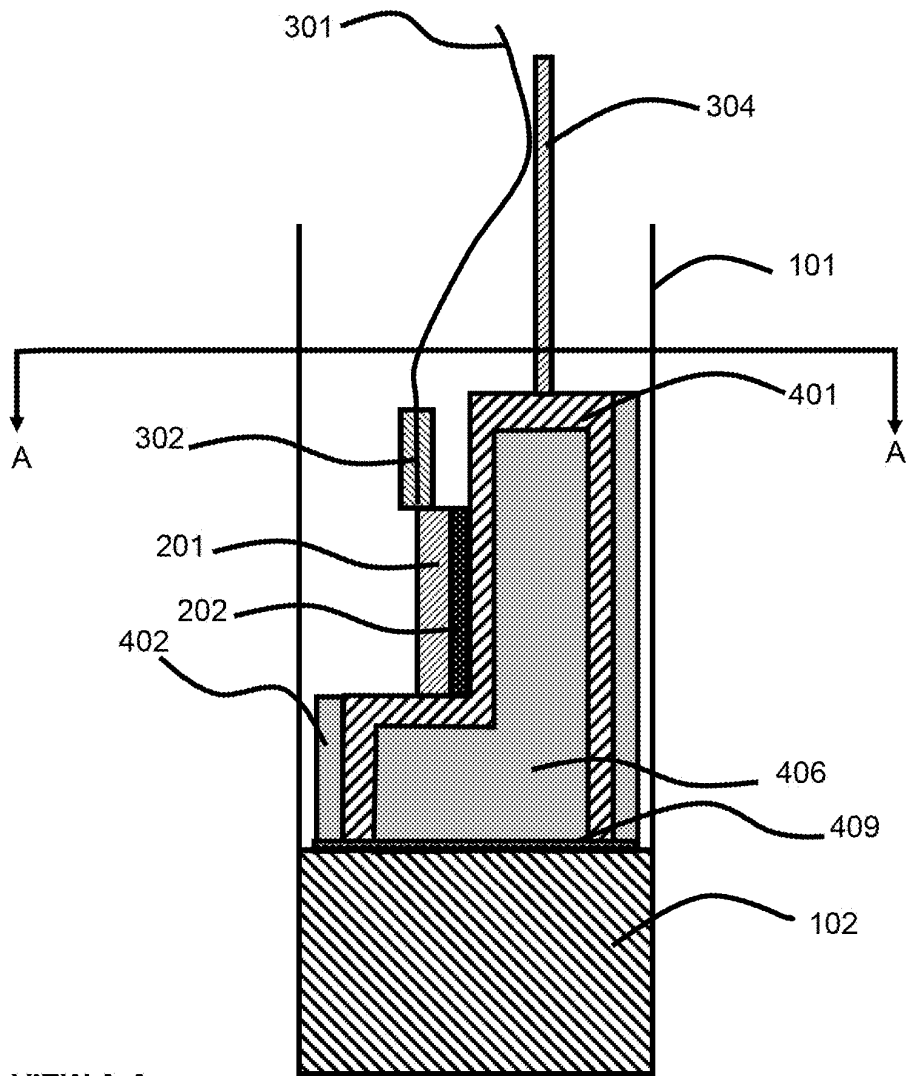

FIG. 29



VIEW A-A

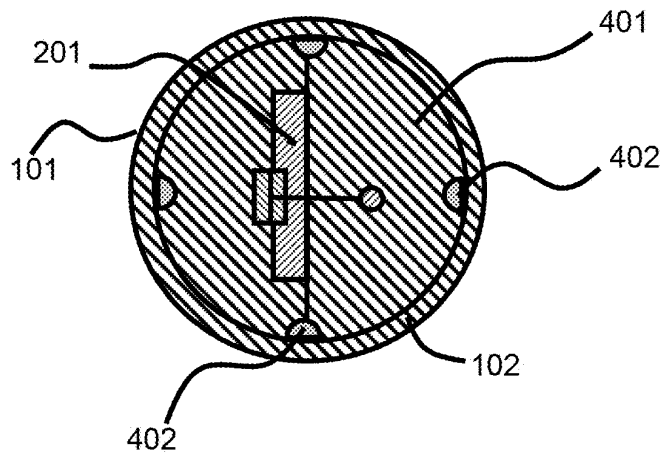
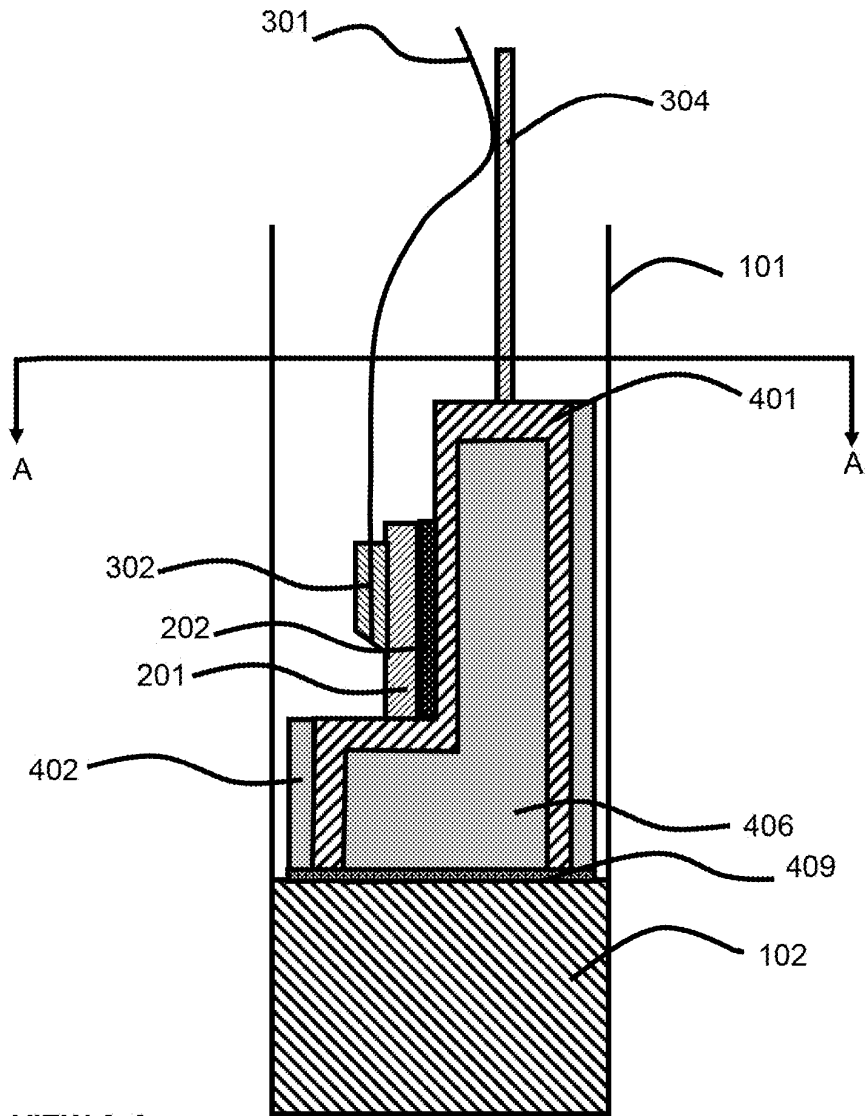

FIG. 30



VIEW A-A

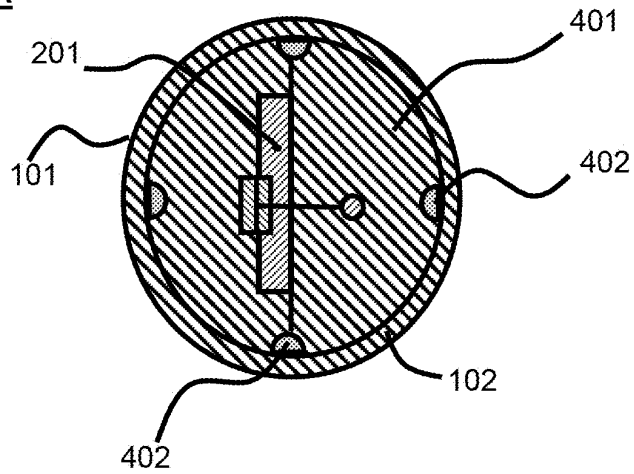

FIG. 31

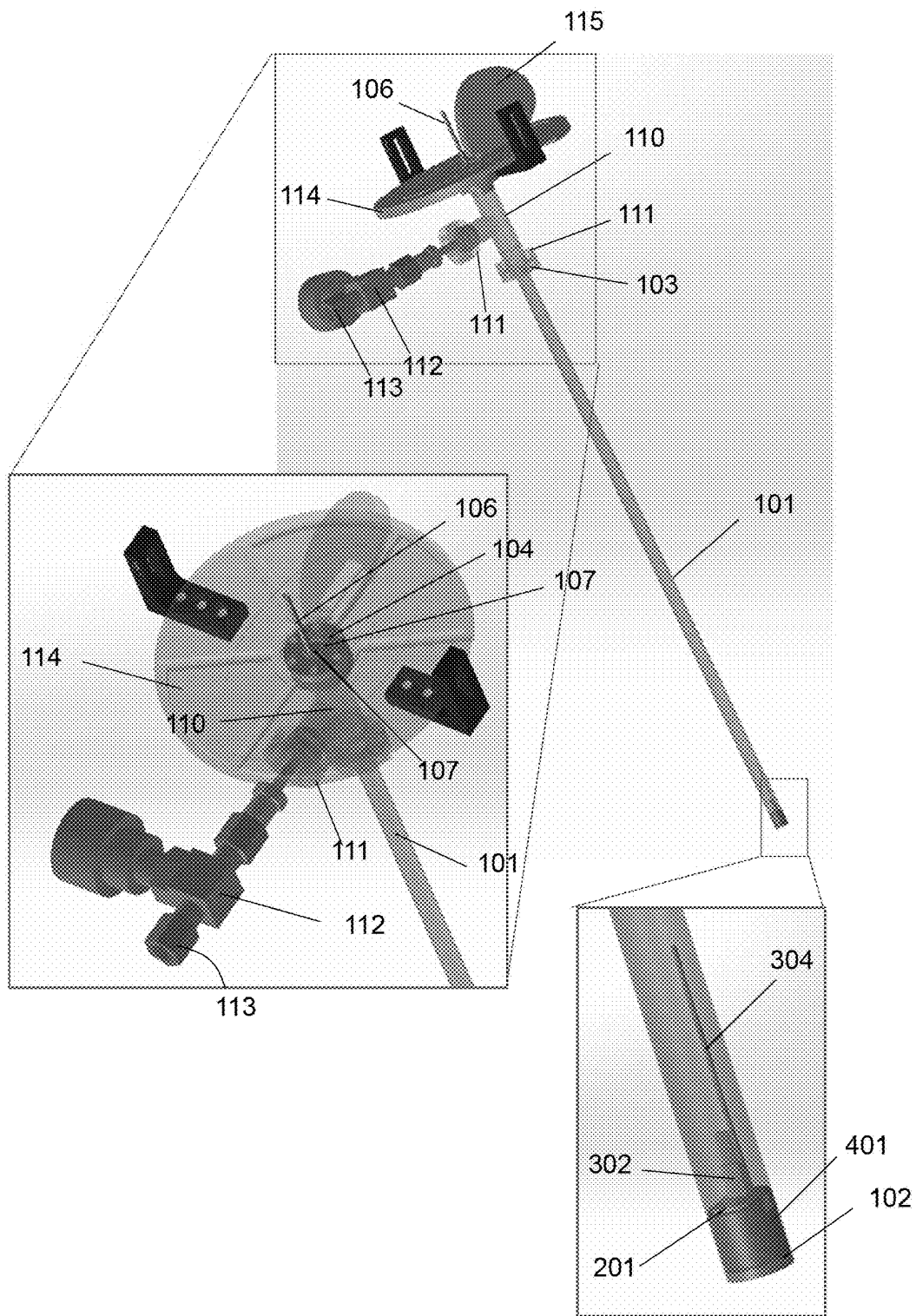

FIG. 32

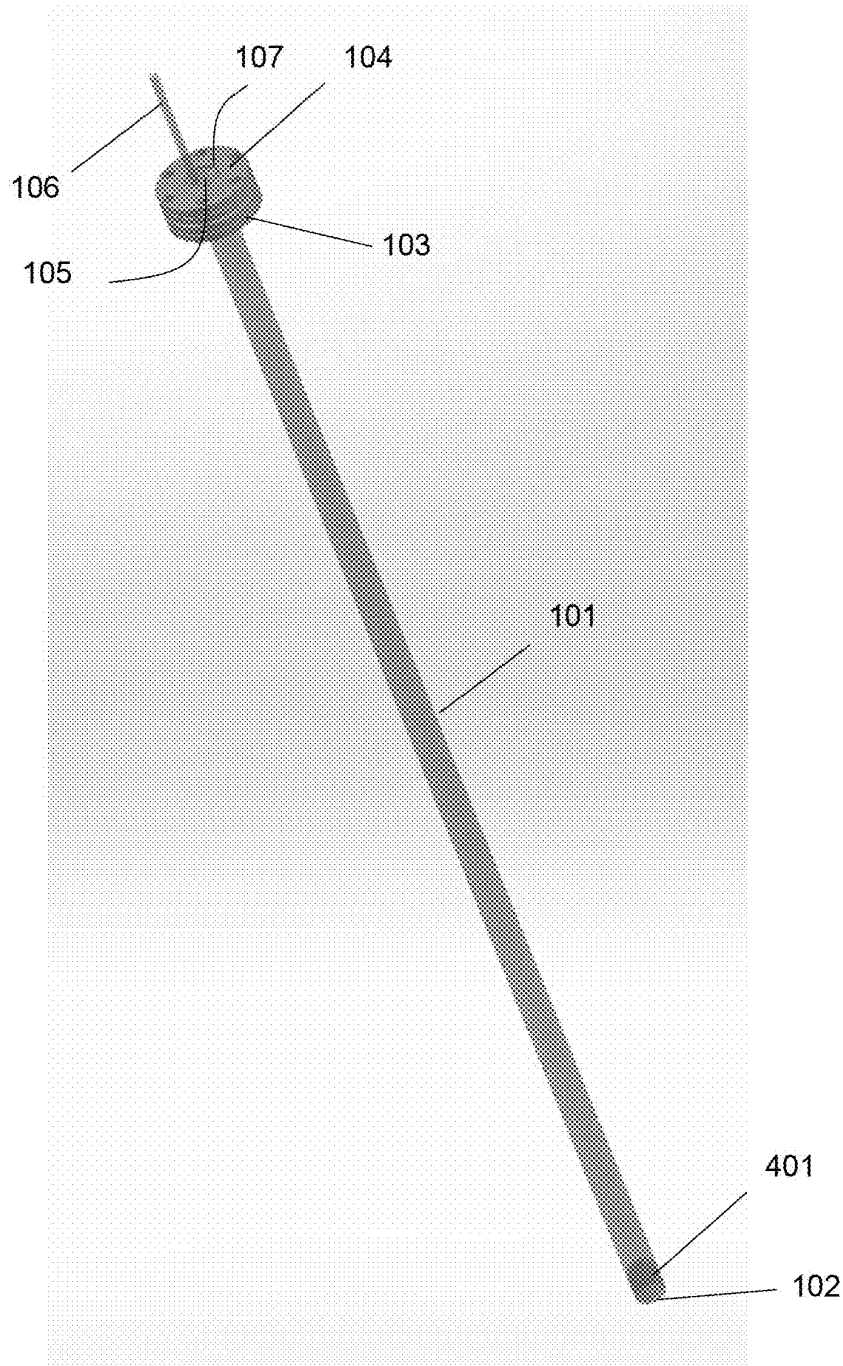

FIG. 33

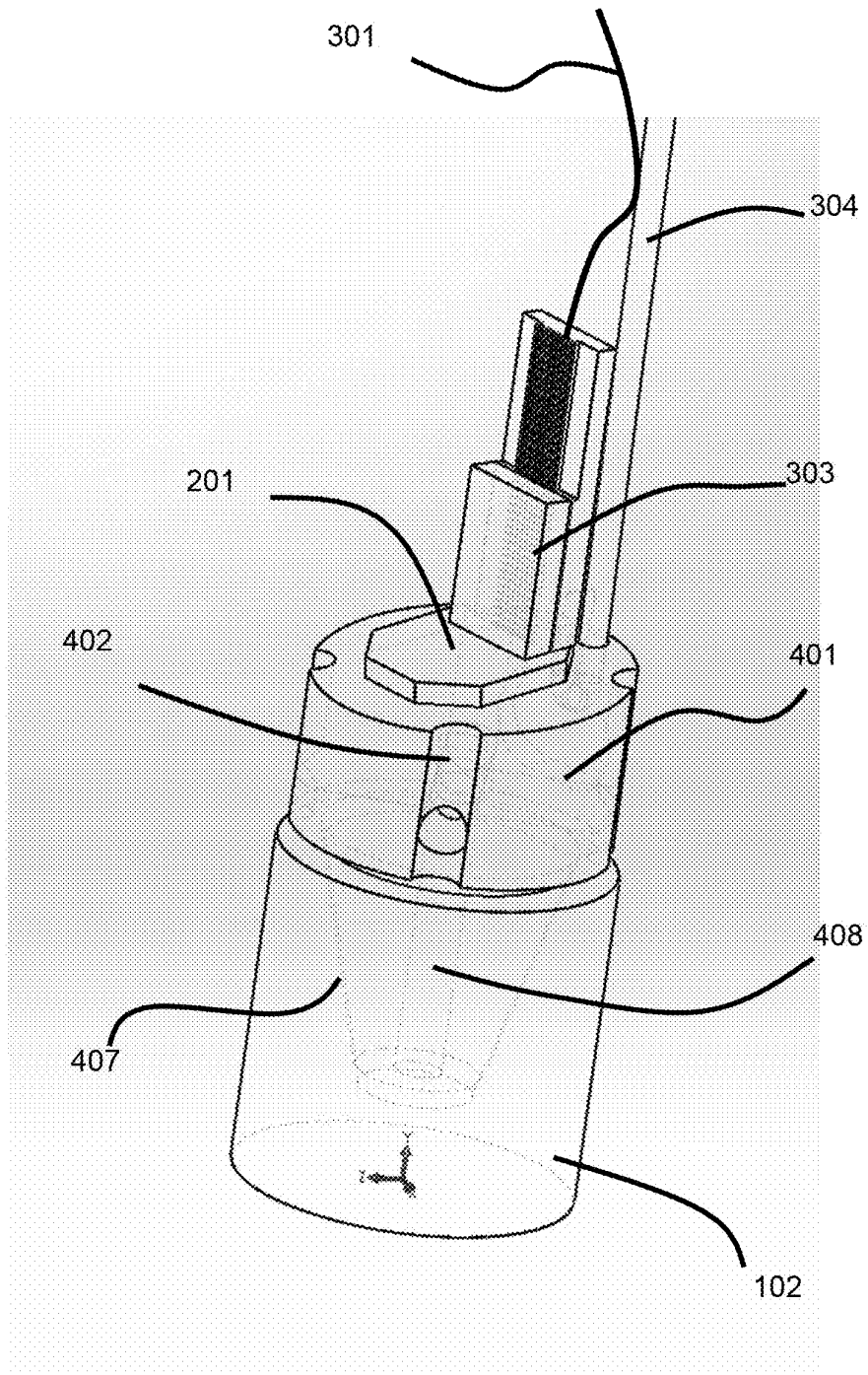

FIG. 34

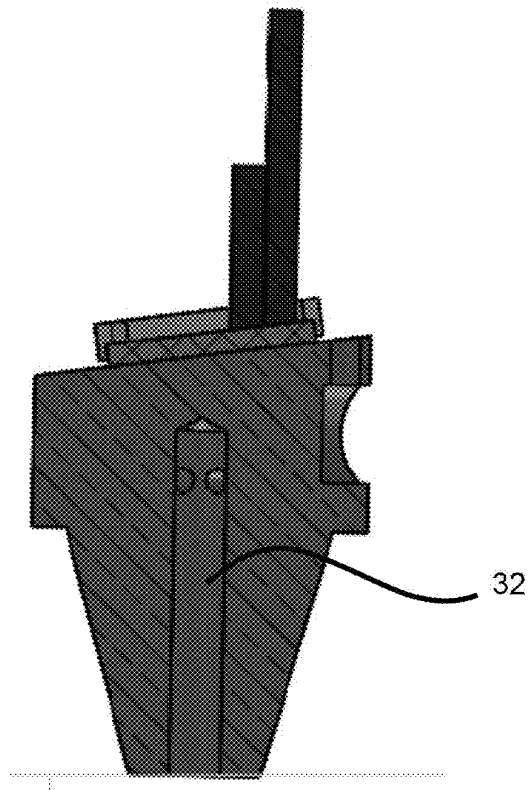
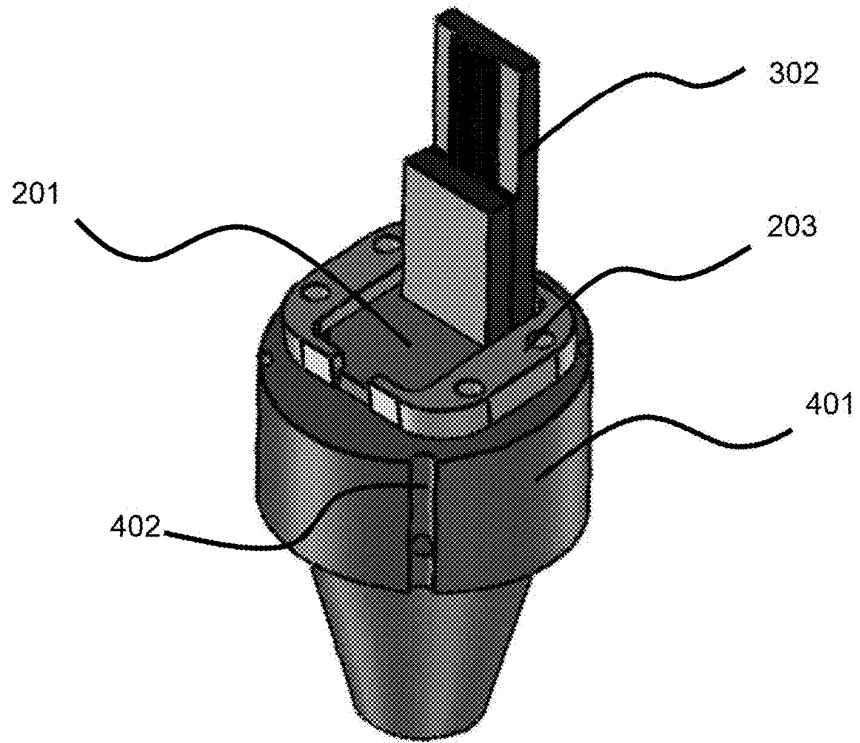

FIG. 35

302

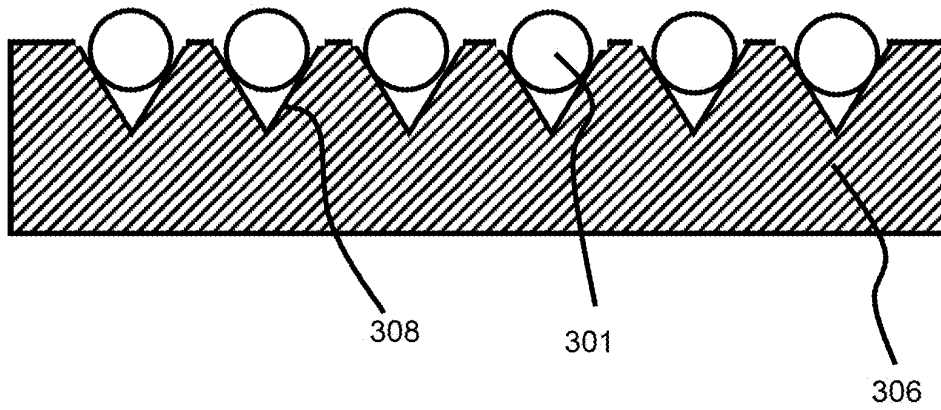

FIG. 36

302

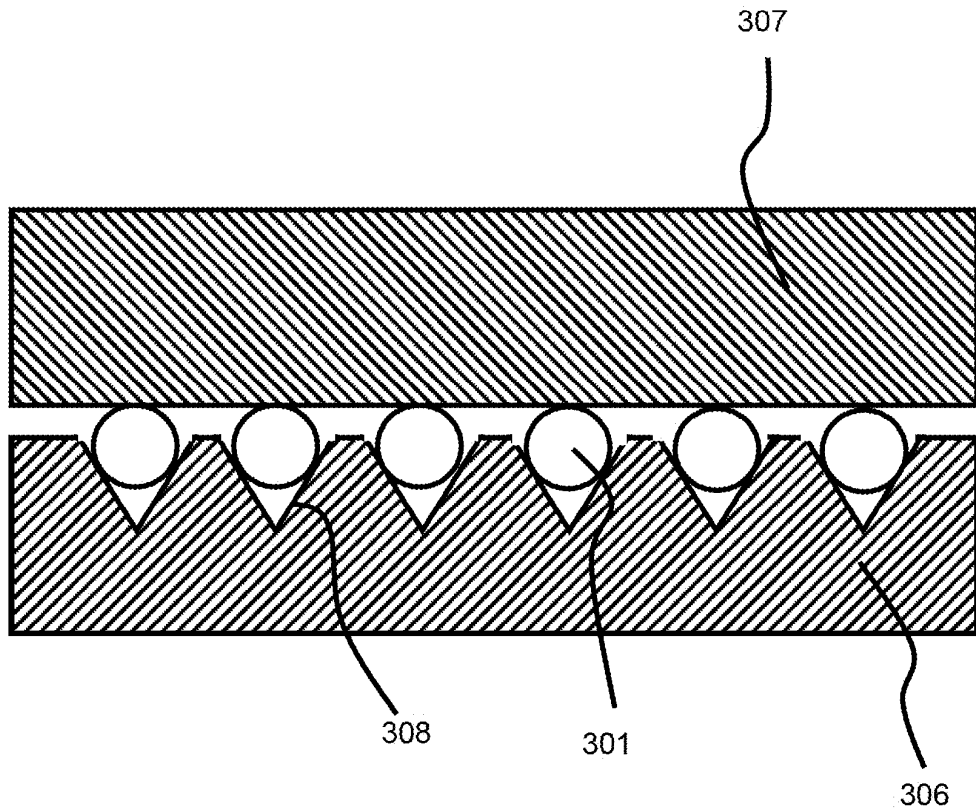

FIG. 37

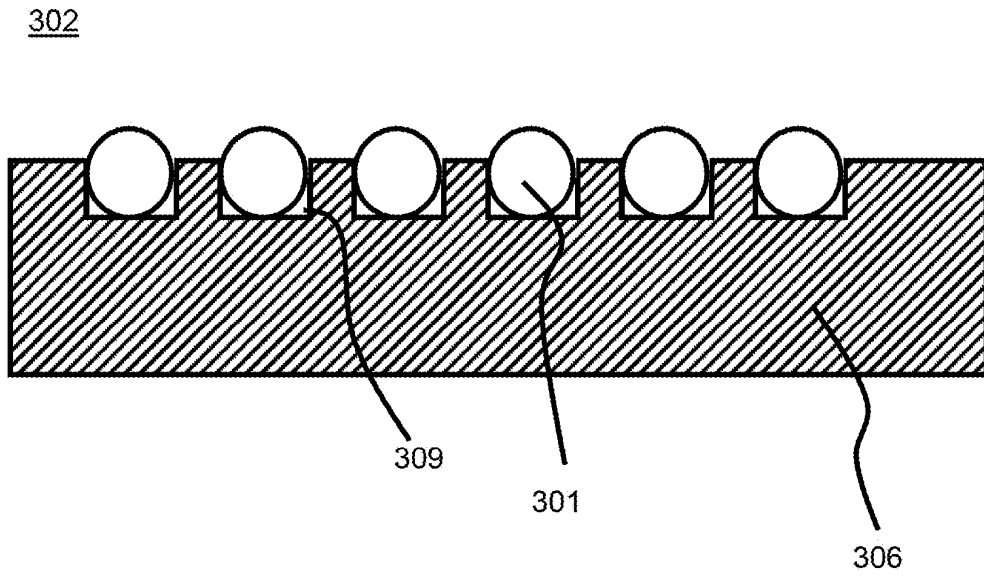

FIG. 38

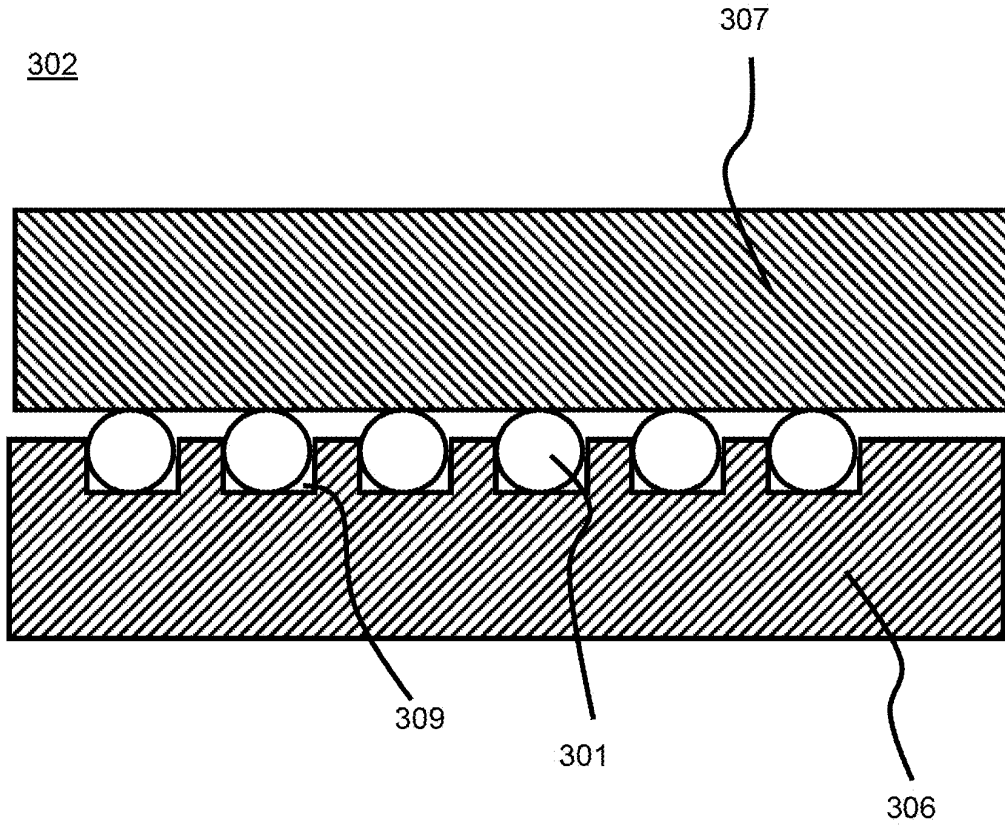

FIG. 39

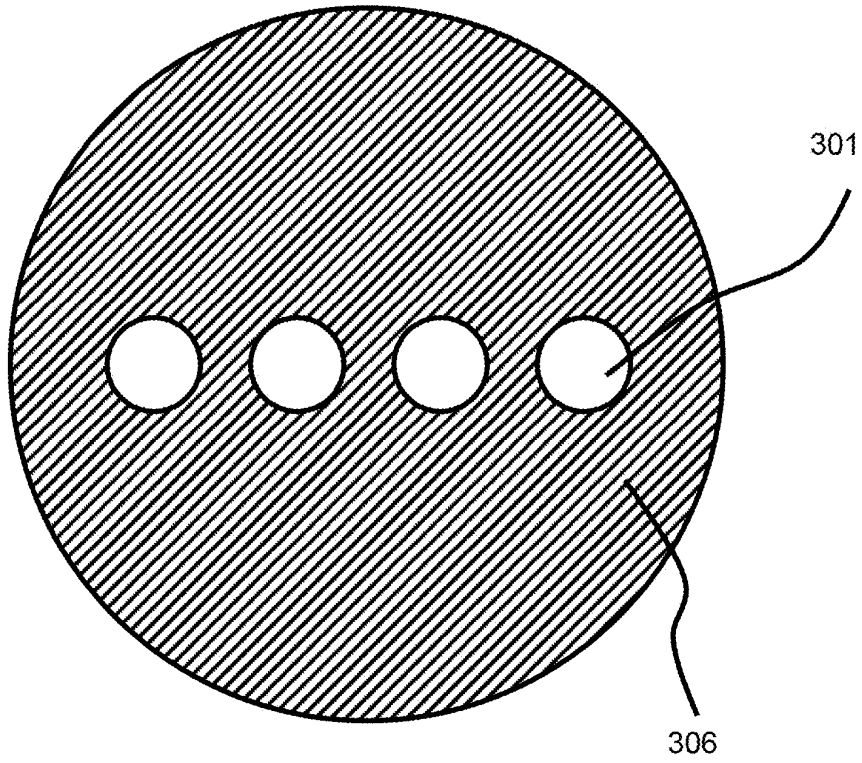

FIG. 40

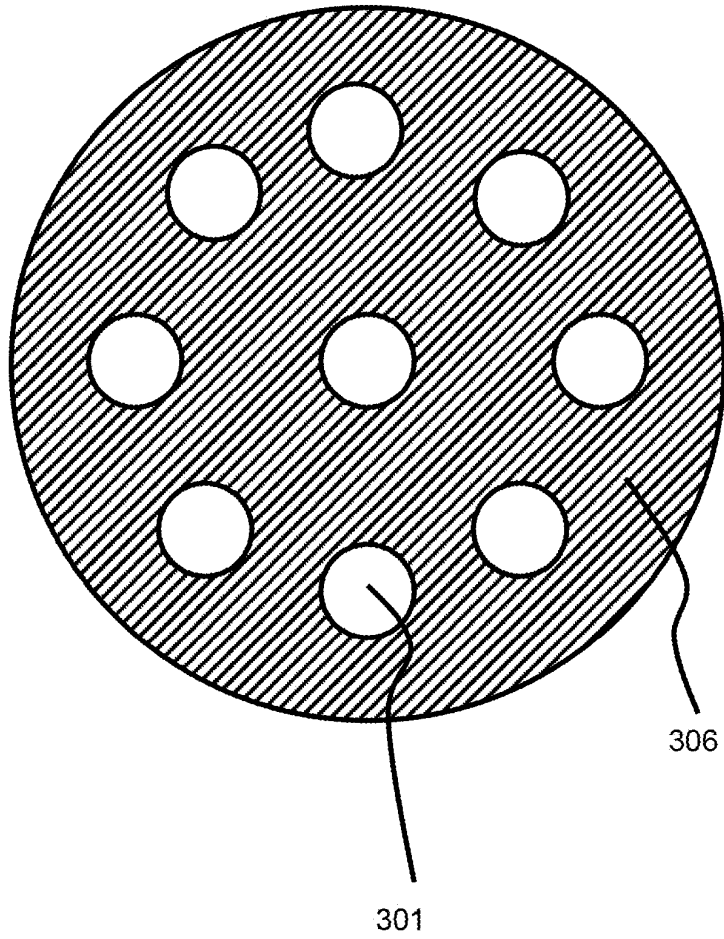

FIG. 41

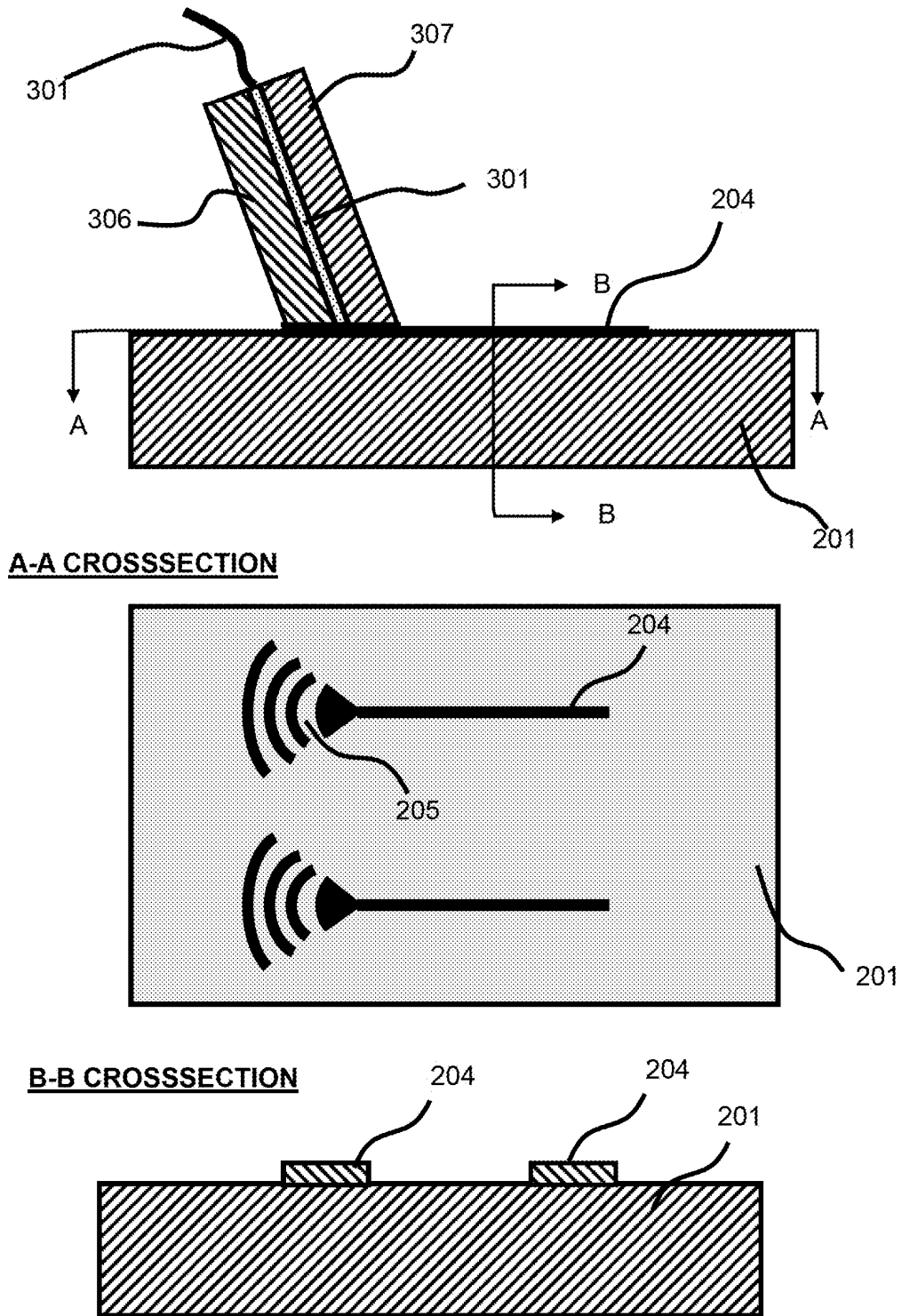

FIG. 42

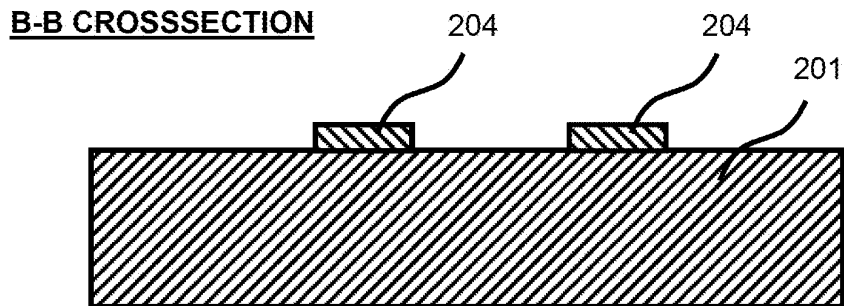
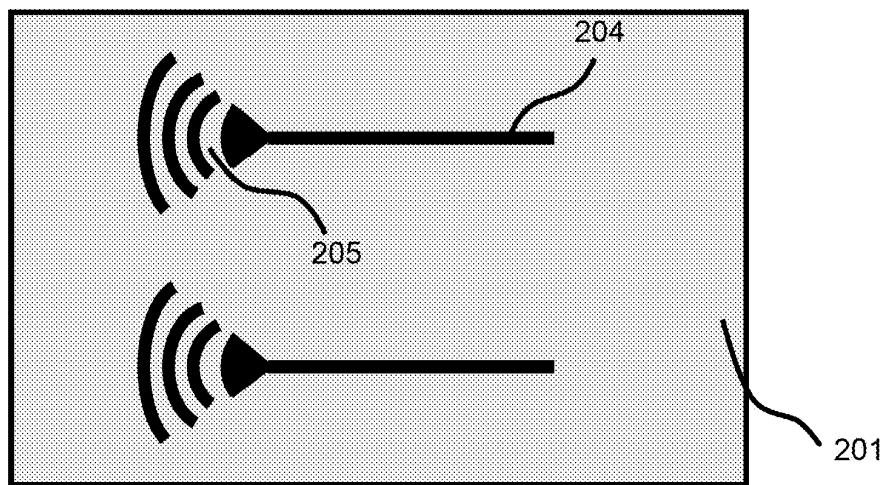
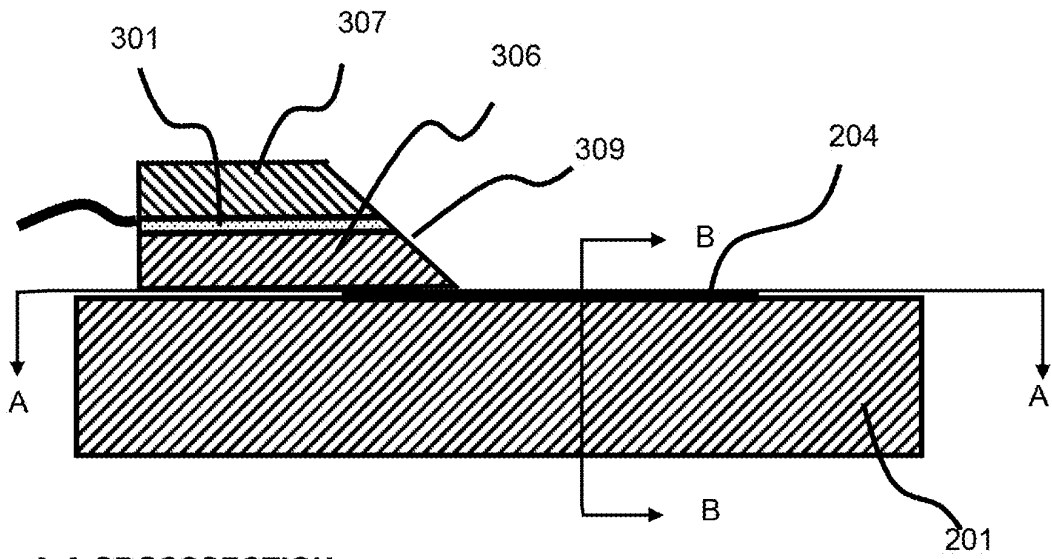
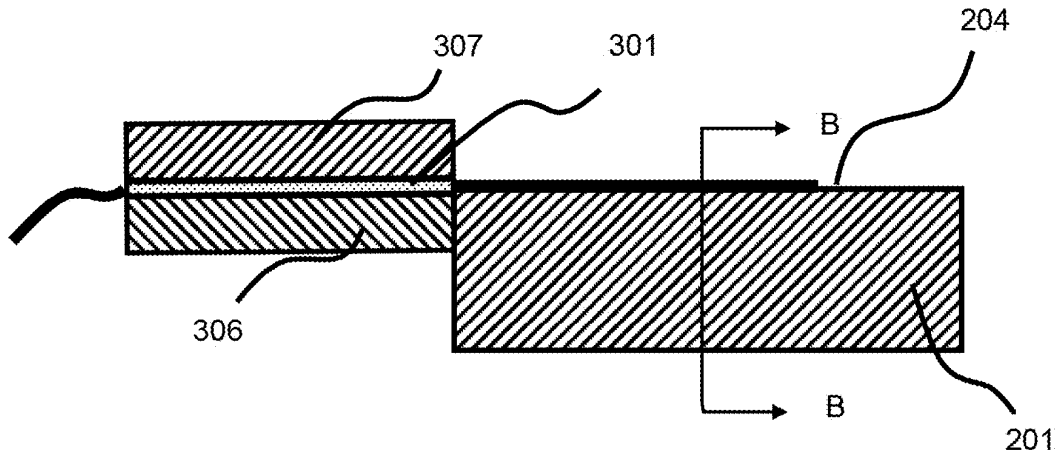

FIG. 43



B-B CROSSSECTION

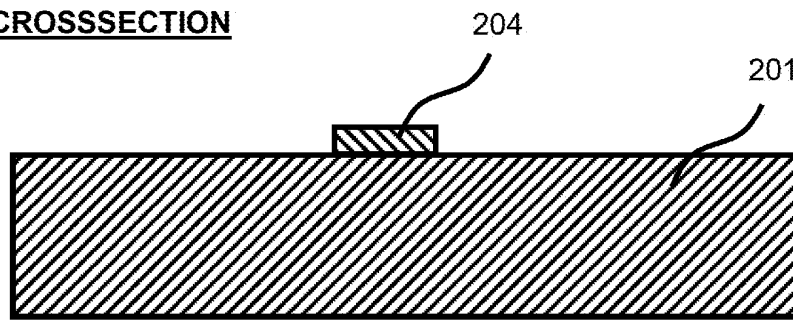

FIG. 44

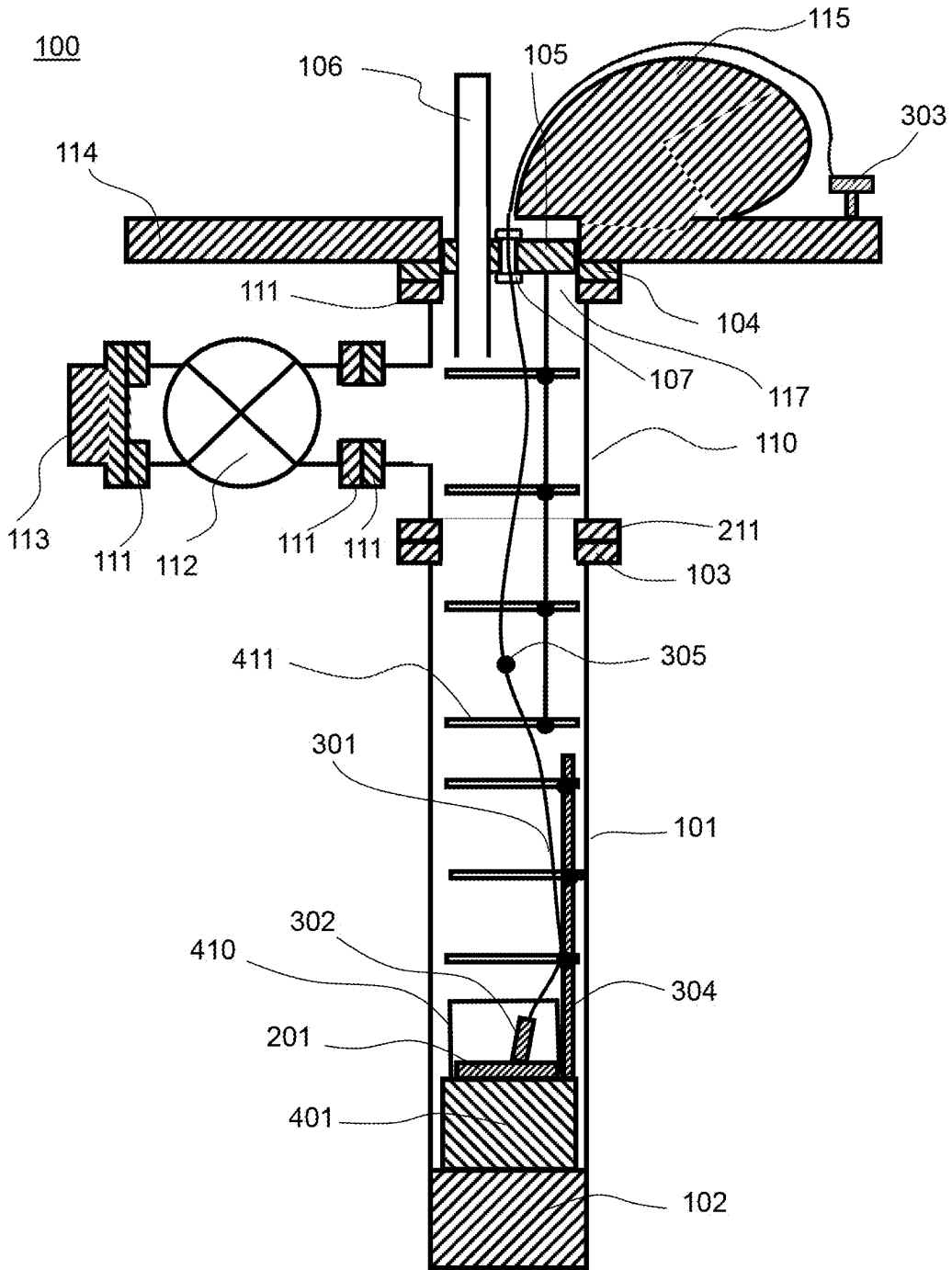

FIG. 45

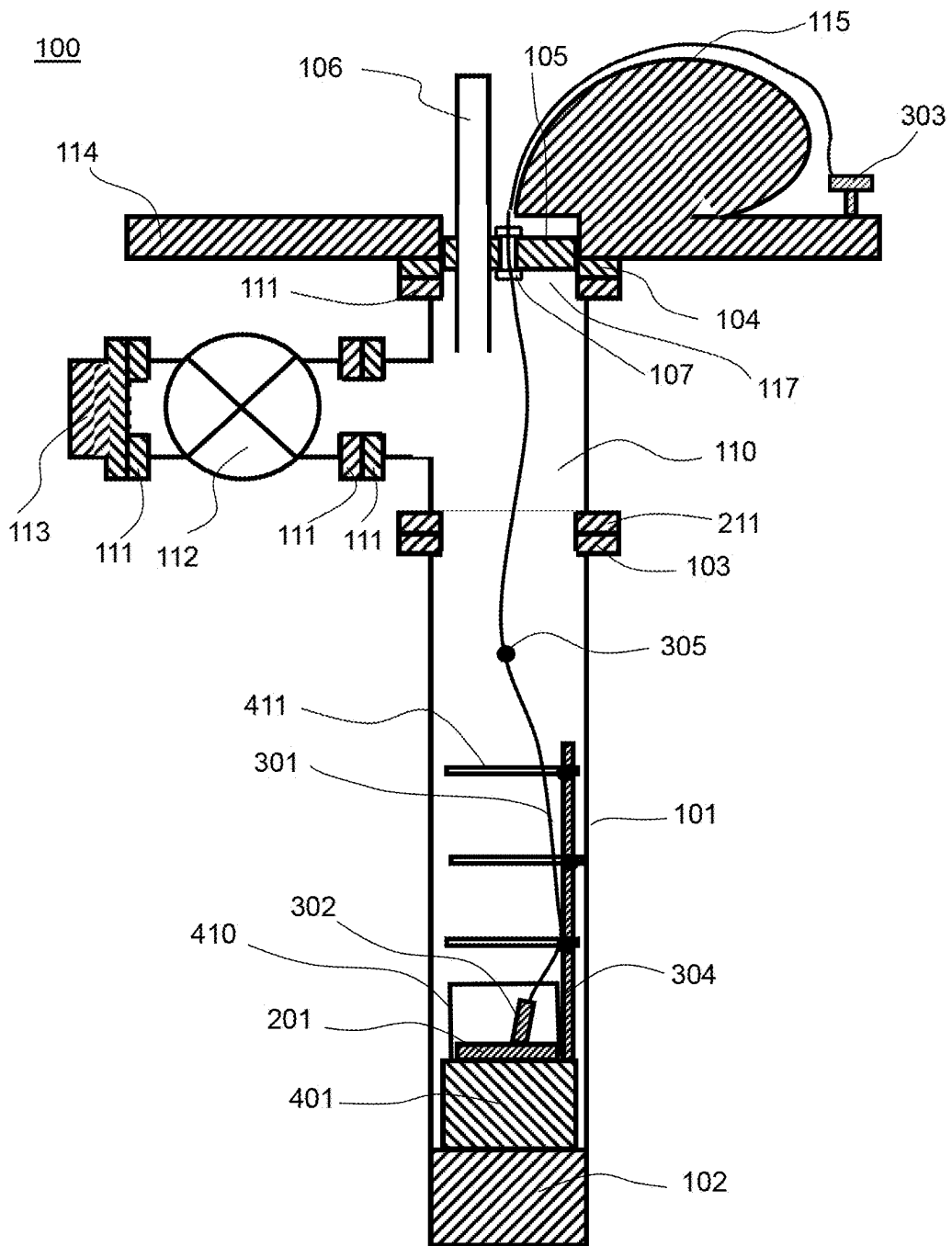

FIG. 46

**PHOTONIC THERMOMETER MODULE
ASSEMBLY AND PERFORMING PHOTONIC
THERMOMETRY**

**CROSS REFERENCE TO RELATED
APPLICATIONS**

[0001] This application claims the benefit of U.S. Provisional Patent Application Ser. No. 63/419,026 (filed Oct. 25, 2022), which is herein incorporated by reference in its entirety.

**STATEMENT REGARDING FEDERALLY
SPONSORED RESEARCH**

[0002] This invention was made with United States Government support from the National Institute of Standards and Technology (NIST), an agency of the United States Department of Commerce. The Government has certain rights in this invention.

BRIEF DESCRIPTION

[0003] Disclosed is a photonic thermometer module assembly for performing photonic thermometry, the photonic thermometer module assembly comprising: a sheath comprising an inner volume, a first end, and a second end disposed at an opposite end of the sheath than the first end; a sheath bottom plug disposed on the sheath at the second end such that the sheath bottom plug hermetically seals the sheath at the second end; a sheath top flange disposed at the first end; a top sealing flange disposed on the sheath top flange at the first end such that the top sealing flange hermetically seals the sheath at the first end; a heat exchanger disposed on the sheath bottom plug such that the heat exchanger is in thermal communication with the sheath bottom plug; a photonic thermometer disposed on the heat exchanger such that: the photonic thermometer is in thermal communication with the sheath bottom plug through the heat exchanger; the heat exchanger is interposed between the photonic thermometer and the photonic thermometer, and the photonic thermometer determines a temperature of the sheath; and an optical fiber array in optical communication with the photonic thermometer and that optically couples the photonic thermometer to an exterior environment of the photonic thermometer module assembly, wherein the photonic thermometer module assembly is compatible with International Temperature Scale of (ITS-90) fixed-point cell infrastructure and conventional drywell and oil-bath calibrations, and the photonic thermometer module assembly provides temperature measurements from -200° C. to $+700^{\circ}$ C.

[0004] Disclosed is a photonic thermometer module assembly for performing photonic thermometry, the photonic thermometer module assembly comprising: a sheath comprising an inner volume, a first end, and a second end disposed at an opposite end of the sheath than the first end; a sheath bottom plug disposed on the sheath at the second end such that the sheath bottom plug hermetically seals the sheath at the second end; a top inner-wall-mount flange disposed at the first end; a top seal plug disposed on the top inner-wall-mount flange at the first end such that the top seal plug hermetically seals the sheath at the first end; a heat exchanger disposed on the sheath bottom plug such that the heat exchanger is in thermal communication with the sheath bottom plug; a photonic thermometer disposed on the heat

exchanger such that: the photonic thermometer is in thermal communication with the sheath bottom plug through the heat exchanger; the heat exchanger is interposed between the photonic thermometer and the photonic thermometer, and the photonic thermometer determines a temperature of the sheath; and an optical fiber array in optical communication with the photonic thermometer and that optically couples the photonic thermometer to an exterior environment of the photonic thermometer module assembly, wherein the photonic thermometer module assembly is compatible with International Temperature Scale of 0 (ITS-90) fixed-point cell infrastructure and conventional drywell and oil-bath calibrations, and the photonic thermometer module assembly provides temperature measurements from -200° C. to $+700^{\circ}$ C.

BRIEF DESCRIPTION OF THE DRAWINGS

[0005] The following description cannot be considered limiting in any way. Various objectives, features, and advantages of the disclosed subject matter can be more fully appreciated with reference to the following detailed description of the disclosed subject matter when considered in connection with the following drawings, in which like reference numerals identify like elements.

[0006] FIG. 1 shows a photonic thermometer module assembly, according to some embodiments.

[0007] FIG. 2 shows an exploded view of photonic thermometer module assembly, according to some embodiments.

[0008] FIG. 3 shows features for a photonic thermometer module assembly such as optical fiber feedthrough disposed on top flange plug, according to some embodiments.

[0009] FIG. 4 shows features for a photonic thermometer module assembly such as optical fiber feedthrough disposed on top flange plug, according to some embodiments.

[0010] FIG. 5 shows features for a photonic thermometer module assembly such as optical fiber feedthrough disposed on top flange plug, according to some embodiments.

[0011] FIG. 6 shows features for a photonic thermometer module assembly such as optical fiber feedthrough disposed on top sealing flange, according to some embodiments.

[0012] FIG. 7 shows features for a photonic thermometer module assembly such as optical fiber feedthrough disposed on top sealing flange, according to some embodiments.

[0013] FIG. 8 shows a photonic thermometer module assembly, according to some embodiments.

[0014] FIG. 9 shows a photonic thermometer module assembly, according to some embodiments.

[0015] FIG. 10 shows an exploded view of a photonic thermometer module assembly, according to some embodiments.

[0016] FIG. 11 shows a photonic thermometer module assembly, according to some embodiments.

[0017] FIG. 12 shows a photonic thermometer module assembly, according to some embodiments.

[0018] FIG. 13 shows features for a photonic thermometer module assembly, according to some embodiments.

[0019] FIG. 14 shows features for a photonic thermometer module assembly, according to some embodiments.

[0020] FIG. 15 shows features for a photonic thermometer module assembly, according to some embodiments.

[0021] FIG. 16 shows features for a photonic thermometer module assembly, according to some embodiments.

[0022] FIG. 17 shows features for a photonic thermometer module assembly, according to some embodiments.

[0023] FIG. 18 shows features for a photonic thermometer module assembly, according to some embodiments.

[0024] FIG. 19 shows features for a photonic thermometer module assembly, according to some embodiments.

[0025] FIG. 20 shows features for a photonic thermometer module assembly, according to some embodiments.

[0026] FIG. 21 shows features for a photonic thermometer module assembly, according to some embodiments.

[0027] FIG. 22 shows features for a photonic thermometer module assembly, according to some embodiments.

[0028] FIG. 23 shows features for a photonic thermometer module assembly, according to some embodiments.

[0029] FIG. 24 shows features for a photonic thermometer module assembly, according to some embodiments.

[0030] FIG. 25 shows features for a photonic thermometer module assembly, according to some embodiments.

[0031] FIG. 26 shows features for a photonic thermometer module assembly, according to some embodiments.

[0032] FIG. 27 shows features for a photonic thermometer module assembly, according to some embodiments.

[0033] FIG. 28 shows features for a photonic thermometer module assembly, according to some embodiments.

[0034] FIG. 29 shows features for a photonic thermometer module assembly, according to some embodiments.

[0035] FIG. 30 shows features for a photonic thermometer module assembly, according to some embodiments.

[0036] FIG. 31 shows features for a photonic thermometer module assembly, according to some embodiments.

[0037] FIG. 32 shows a photonic thermometer module assembly, according to some embodiments.

[0038] FIG. 33 shows a photonic thermometer module assembly, according to some embodiments.

[0039] FIG. 34 shows features for a photonic thermometer module assembly, according to some embodiments.

[0040] FIG. 35 shows features for a photonic thermometer module assembly, according to some embodiments.

[0041] FIG. 36 shows an optical fiber expander, according to some embodiments.

[0042] FIG. 37 shows an optical fiber expander, according to some embodiments.

[0043] FIG. 38 shows an optical fiber expander, according to some embodiments.

[0044] FIG. 39 shows an optical fiber expander, according to some embodiments.

[0045] FIG. 40 shows an optical fiber array disposed on a fiber expander base for a photonic thermometer module assembly, according to some embodiments.

[0046] FIG. 41 shows an optical fiber array disposed on a fiber expander base for a photonic thermometer module assembly, according to some embodiments.

[0047] FIG. 42 shows an optical fiber array disposed on a photonic thermometer for a photonic thermometer module assembly, according to some embodiments.

[0048] FIG. 43 shows an optical fiber array disposed on a photonic thermometer for a photonic thermometer module assembly, according to some embodiments.

[0049] FIG. 44 shows an optical fiber array disposed on a photonic thermometer for a photonic thermometer module assembly, according to some embodiments.

[0050] FIG. 45 shows a photonic thermometer module assembly, according to some embodiments.

[0051] FIG. 46 shows a photonic thermometer module assembly, according to some embodiments.

DETAILED DESCRIPTION

[0052] A detailed description of one or more embodiments is presented herein by way of exemplification and not limitation.

[0053] It has been discovered that photonic thermometer module assembly 100 is a mechanically robust, modular design packaging solution for a fiber-coupled photonic temperature sensor. The modularized assembly of photonic thermometer module assembly 100 provides fast swapping of components. Beneficially, photonic thermometer module assembly 100 provides for temperature measurements with a fiber-coupled photonic thermometer over a broad temperature range, e.g., from -200°C . to $+700^{\circ}\text{C}$. is compatible with International Temperature Scale of 1990 (ITS-90) fixed-point cell infrastructure and conventional drywell and oil-bath calibrations. Advantageously, photonic thermometer module assembly 100 can be reused with different photonic thermometers disposed therein. Fiber-coupled chips (photonic thermometers) can be easily swapped (plugged-in-place) in photonic thermometer module assembly 100. Photonic thermometer module assembly 100 has reconfigurable modular design, wherein independent modules are reusable, interchangeable, or swappable, or reconfigurable. It is contemplated that various components are swappable so that such component can be replaced by another component of its kind (e.g., a flange replaced by another type of flange). In some embodiments, a photonic thermometer is interchangeable in that the photonic thermometer can be replaced with a different photonic thermometer, wherein the replacement photonic thermometer behaving very similarly to replaced photonic thermometer. Photonic thermometer module assembly 100 can be opened for replacement of the photonic thermometer while reusing various other components. Photonic thermometer module assembly 100 can have one of various configurations when all or selected modules are simultaneously present. In an embodiment, photonic thermometer module assembly 100 includes a minimal base set of modules that minimizes a weight and size of photonic thermometer module assembly 100.

[0054] In an embodiment, photonic thermometer module assembly 100 has a form-factor or size similar to the dimensions of a standard platinum resistance thermometer (SPRT) and can be used in fixed-point cells with phase-transition temperatures defined within the International Temperature Scale of 1990 (ITS-90). Accordingly, photonic thermometer module assembly 100 can be used as a photonic thermometer for photonic thermometry in ITS-90 fixed-point cells, standard temperature calibrators, or oil baths.

[0055] In an embodiment, with reference to FIG. 1, FIG. 2, and the like, photonic thermometer module assembly 100 includes sheath 101 including first end 108 and second end 109 at an opposite end of sheath 101, sheath bottom plug 102 disposed on sheath 101 at second end 109, sheath top flange 103 disposed on sheath 101 at first end 108, photonic thermometer 201 disposed in inner volume 121 of sheath 101, optical fiber array 301 connected to and in optical communication with photonic thermometer 201 via optical fiber expander 302, and heat exchanger 401 in thermal communication with photonic thermometer 201, such that

photonic thermometer 201 is disposed on heat exchanger 401; and optionally thermally conductive layer 202 interposed between photonic thermometer 201 and heat exchanger 401 and that provides thermal communication among photonic thermometer 201 and heat exchanger 401.

[0056] In an embodiment, photonic thermometer module assembly 100 includes flanged tee-coupler 110 disposed on sheath 101 proximate to first end 108. Flanged tee-coupler 110 can include a plurality of coupling flange 111, e.g., three coupling flanges 111, wherein one of coupling flange 111 is disposed on sheath top flange 103 of sheath 101. In an embodiment, photonic thermometer module assembly 100 includes vacuum valve 112 in fluid communication with inner volume 121 of sheath 101. Vacuum valve 112 can be disposed on flanged tee-coupler 110. An inlet port of vacuum valve 112 can be covered with vacuum valve plug 113.

[0057] In an embodiment, photonic thermometer module assembly 100 includes top sealing flange 104 disposed on sheath top flange 103. According to an embodiment, flanged tee-coupler 110 is interposed between top sealing flange 104 and sheath top flange 103. Various features can be disposed on top sealing flange 104 such as top flange plug 105, exchange gas evacuation/filling tube 106, optical fiber feedthrough 107, optical fiber support collar 114, or optical fiber support fin 115. Exchange gas evacuation/filling tube 106 is in fluid communication with inner volume 121 and provide evacuation of gas from inner volume 121 or introduction of gas into inner volume 121. Optical fiber feedthrough 107 provides a path through which optical fiber array 301 can be coupled from exterior 122 to inner volume 121. To alleviate strain on optical fiber connected to optical fiber feedthrough 107, optical fiber support fin 115 provides strain relief by disposing the optical fiber thereon for a non-abrupt physical transition out of inner volume 121. It should be appreciated that the optical fiber array can be in optical communication with the photonic thermometer and configured to optically couple the photonic thermometer to an exterior environment so that a light source can provide light to the optical fiber and photonic chip. Wherein the light communicates from the light to the photonic via the optical fiber.

[0058] In an embodiment, photonic thermometer module assembly 100 includes optical fiber array 301 disposed in sheath 101. Optical fiber array 301 is guided via optical fiber feedthrough 107 into inner volume 121 through top sealing flange 104 or top flange plug 105. The optical fiber of optical fiber array 301 can include one optical fiber, an optical fiber bundle that includes a plurality of individual optical fibers, or an optical fiber ribbon that includes conjoined optical fibers. One end of optical fiber array 301 is connected to photonic thermometer 201 proximate to second end 109 directly or via optical fiber expander 302. The other end of optical fiber array 301 can be terminated with fiber connector 303. Optical fiber array 301 can be connected to fiber strain relief post 304 that is attached to heat exchanger 401. Optical fiber array 301 can include fiber splice joint 305 to optically interconnect a pigtail of optical fiber array 301 from optical fiber expander 302 with a portion of optical fiber disposed in optical fiber feedthrough 107 from exterior 122 of photonic thermometer module assembly 100.

[0059] In an embodiment, photonic thermometer module assembly 100 includes heat exchanger 401 disposed in inner volume 121 at second end 109 and in thermal communication with photonic thermometer 201, wherein there can be direct contact or indirect contact (via thermally conductive

layer 202) between heat exchanger 401 and photonic thermometer 201. In an embodiment, heat exchanger 401 includes heat exchanger cavity 406, air escape trench 402, or a combination thereof. In an embodiment, heat exchanger 401 is in thermal communication with sheath bottom plug 102 directly or via bottom plug thermally conductive layer 409. In an embodiment, heat exchanger 401 is disposed on sheath bottom plug 102 via bottom plug thermally conductive layer 409, heat exchanger-to-bottom plug threaded lock joint 403, a magnetic force generated by heat exchanger magnet 404 and/or bottom plug magnet 405, or a combination thereof. In an embodiment, heat exchanger 401 is connected to sheath bottom plug 102 by conical self-aligning heat exchanger-to-bottom plug joint. In an embodiment, heat exchanger 401 includes heat exchanger cavity 406, air escape trench 402, air escape inner channel 408, or a combination thereof. Thermally conductive layer 409 can have an adhesive property (e.g., it can be thermally conductive epoxy) to adhere heat exchanger 401 to sheath bottom plug 102. Threaded lock joint 403 and magnets 404/405 can be used in combination or separately (so that either 403 or 404/405 is absent). If heat exchanger 401 or sheath bottom plug 102 is magnetic, one magnet (405 or 404) need be used.

[0060] In an embodiment, sheath bottom plug 102 is a heat exchanger when photonic thermometer 201 is disposed directly on sheath bottom plug 102 with bottom plug thermally conductive layer 409 optionally interposed between photonic thermometer 201 and sheath bottom plug 102. In an embodiment, sheath bottom plug 102 can be reversibly attached or permanently attached to sheath 101 or bottom inner-wall-mount flange 120.

[0061] In an embodiment, with reference to FIG. 46, photonic thermometer module assembly 100 includes thermal shield 410 disposed on photonic thermometer 201 so that photonic thermometer 201 is sensitive to the temperature of heat exchanger 401 and blocked from temperature gradients and temperature fluctuations in inner volume 121.

[0062] In an embodiment, with reference to FIG. 45 and FIG. 46, photonic thermometer module assembly 100 includes baffle disk 411 disposed in inner volume 121 of sheath 101. The number of baffle disks 411 can be selected to reduce thermal convection in inner volume 121. A stack of baffle disk 411 sheath 101 can be supported by fiber strain relief post 304 proximate to second end 109 or can be suspended from top sealing flange 104 at first end 108.

[0063] Photonic thermometer module assembly 100 can be made of various elements and components that are modularly assembled together. Elements of photonic thermometer module assembly 100 can be various sizes. It is contemplated that the size of the elements can be selected based on an environment or context in which photonic thermometer module assembly 100 is used. Elements of photonic thermometer module assembly 100 can be made of a material that is physically or chemically resilient in an environment in which photonic thermometer module assembly 100 is disposed. Exemplary materials include a metal, ceramic, thermoplastic, glass, semiconductor, and the like. The elements of photonic thermometer module assembly 100 can be made of the same or different material and can be monolithic in a single physical body or can be separate members that are physically joined.

[0064] In an embodiment, photonic thermometer module assembly 100 includes sheath 101. Sheath 101 have a transverse cross-section that is circular. An inner diameter of

sheath **101** can be from 1 mm to 20 mm. Sheath length **L** can be from 1 cm to 60 cm (e.g., as shown in FIG. 1, FIG. 8, FIG. 9, FIG. 11, FIG. 12). It is contemplated that inner volume **121** is large enough to accommodate photonic thermometer **201**.

[0065] In an embodiment, sheath bottom plug **102** is connected to sheath **101** at second end **109** either directly (FIG. 1, FIG. 2, FIG. 8, FIG. 9, FIG. 10, FIG. 11) or via bottom inner-wall-mount flange **120** (FIG. 12). Bottom inner-wall-mount flange **120** can be attached in various mechanical ways such as being glued, welded, soldered, fused, or crimped to sheath **101**. Sheath bottom plug **102** can be attached in various mechanical ways such as being glued, welded, soldered, fused, or crimped. Sheath bottom plug **102** can be absent from photonic thermometer module assembly **100** when sheath **101** includes a seal on its bottom end (e.g., a spherical shape weld) at second end **109**.

[0066] In an embodiment, sheath top flange **103** is disposed on sheath **101** at first end **108** and opposes sheath bottom plug **102**. Sheath top flange **103** can be attached in various mechanical ways such as being glued, welded, soldered, fused, or crimped to sheath **101**. In photonic thermometer module assembly **100**, sheath top flange **103** provides quick connecting or disconnecting of components of photonic thermometer module assembly **100** and provides high vacuum (HV) or ultra-high vacuum (UHV) level seal for sheath **101**. Moreover, sheath top flange **103** can be sealed to maintain a selected pressure or gas composition in inner volume **121**.

[0067] In an embodiment, flanged tee-coupler **110** includes a plurality of vacuum ports, e.g., three vacuum ports, each of which can be terminated with coupling flange **111**. Flanged tee-coupler **110** is disposed on sheath top flange **103** to provide an HV or UHV level vacuum seal.

[0068] In an embodiment, vacuum valve **112** can be disposed on flanged tee-coupler **110**, wherein an inlet or outlet port of vacuum valve **112** can include an HV or UHV connector interface. An outlet of vacuum valve **112** is disposed on coupling flange **111** of flanged tee-coupler **110**. Vacuum valve **112** is used to evacuate inner volume **121** of sheath **101** or to fill inner volume **121** with a gas (e.g., an inert gas) to minimize an effect of environmental factors such as oxygen, humidity, or moisture on photonic thermometer **201**. The inlet port of vacuum valve **112** can be blanked with vacuum valve plug **113** when vacuum valve **112** is left at a closed position for a period of time.

[0069] In certain embodiments, flanged tee-coupler **110**, vacuum valve **112**, or vacuum valve plug **113** is optional and can be absent in photonic thermometer module assembly **100**, e.g., as shown in FIG. 8, FIG. 9, FIG. 10, FIG. 11, or FIG. 12.

[0070] In an embodiment, photonic thermometer module assembly **100** includes top sealing flange **104** disposed on sheath top flange **103** or coupling flange **111** of flanged tee-coupler **110**. Top sealing flange **104** can have a circular through-flange top sealing flange aperture **117** located at a center of top sealing flange **104**. Top sealing flange aperture **117** transfers photonic thermometer **201** with heat exchanger **401** into sheath **101**.

[0071] In an embodiment, top flange plug **105** seals top sealing flange aperture **117** of top sealing flange **104** after photonic thermometer **201** disposed on heat exchanger **401** are disposed in sheath **101**. The seal between top flange plug **105** and top sealing flange **104** can be a result of gluing,

soldering, brazing, or a interposing a gasket (e.g., made of rubber, metal, or a composite) therebetween.

[0072] In an embodiment, exchange gas evacuation/filling tube **106** is disposed on top flange plug **105**. Exchange gas evacuation/filling tube **106** can be attached to top sealing flange **104** such attachment can be a result of be gluing, welding, soldering, brazing, or fusing exchange gas evacuation/filling tube **106** to plug top sealing flange **104**. Exchange gas evacuation/filling tube **106** is in fluid communication with inner volume **121** to evacuate sheath **101** or to fill sheath **101** with gas (e.g., an inert gas) to minimize the effect of environmental factors such as oxygen, humidity, or moisture on photonic thermometer **201**. After evacuating inner volume **121** of sheath **101** or filling sheath **101** with gas, exchange gas evacuation/filling tube **106** is sealed, e.g., by splicing, cold fusion, crimping, soldering, welding, and the like. Exchange gas evacuation/filling tube **106** can be made from a metal such as copper, nickel, stainless steel, metal alloy, and the like.

[0073] In an embodiment, top flange plug **105** includes optical fiber feedthrough **107** to communicate optical fibers, e.g., optical fiber array **301**, through top flange plug **105** from exterior **122** into inner volume **121**. Optical fiber feedthrough **107** can be disposed in top flange plug **105** (FIG. 3) such that optical fiber array **301** is communicated through optical fiber feedthrough **107**. In an embodiment, optical fiber array **301** is disposed in top flange plug **105** such that optical fiber array **301** is in direct contact with top flange plug **105** (FIG. 5). As shown in FIG. 5, optical fiber array **301** can be communicated to inner volume **121** via a fiber slit in top flange plug **105** (FIG. 4).

[0074] In an embodiment, top flange plug **105** is optionally absent when top sealing flange **104**, in place of aperture top sealing flange aperture **117**, includes exchange gas evacuation/filling tube **106** and optical fiber feedthrough **107** (FIG. 6, FIG. 7).

[0075] In an embodiment, various flanged elements, e.g., sheath top flange **103**, top sealing flange **104**, coupling flange **111**, or vacuum valve plug **113**, in combination together form an HV or UHV level vacuum seal using a gasket that include a metal, metal alloy, elastomer (e.g., rubber), plastic, composite material, and the like.

[0076] In an embodiment, photonic thermometer module assembly **100** includes optical fiber support collar **114** disposed on top sealing flange **104**, wherein optical fiber support collar **114** mechanically supports optical fiber array **301** proximate to optical fiber feedthrough **107**. Optical fiber support collar **114** can include optical fiber support fin **115** that supports optical fiber array **301** and minimizes sharp bending of optical fiber array **301**. If optical fiber array **301** is terminated with fiber connector **303**, fiber connector **303** can be disposed on optical fiber support collar **114**. Optical fiber support collar **114** can be made from a plastic, polymeric, composite material, and the like.

[0077] In an embodiment, with reference to FIG. 8, FIG. 9, FIG. 10, FIG. 11, FIG. 12, and FIG. 33, photonic thermometer module assembly **100** includes a configuration of elements, wherein certain element are absent such as flanged tee-coupler **110**, vacuum valve **112**, vacuum valve plug **113**, or optical fiber support collar **114**. The embodiments of photonic thermometer module assembly **100** shown in FIG. 8, FIG. 9, FIG. 10, FIG. 11, FIG. 12, and FIG.

33 can be a minimum configuration for performing photonic thermometry with photonic thermometer module assembly 100.

[0078] In an embodiment, sheath bottom plug 102 is permanently attached to sheath 101 (e.g., as shown in FIG. 1, FIG. 9, or FIG. 11). Attachment can be made via gluing, soldering, welding, brazing, and the like. In an embodiment, sheath bottom plug 102 is detachably fastened to sheath 101 such that fastening can occur by a joint such as a flange-type joint that provides detachment and reattachment, wherein sheath bottom plug 102 is removable from sheath 101 (FIG. 12).

[0079] In an embodiment, photonic thermometer module assembly 100 has minimalistic dimensions, wherein first end 108 of sheath 101 is sealed with top seal plug 119 (FIG. 11, FIG. 12). Top seal plug 119 can be attached to top inner-wall-mount flange 118, wherein top inner-wall-mount flange 118 can be glued, welded, soldered, brazed, and the like to sheath 101. Top seal plug 119 can be permanently attached to sheath 101 directly or indirectly via top inner-wall-mount flange 118, e.g., by welding, soldering, gluing, brazing, and the like, or can be removably attached via a flange-type joint with a sealing gasket interposed between top seal plug 119 and top inner-wall-mount flange 118.

[0080] In an embodiment, with reference to FIG. 12, to reduce size L of photonic thermometer module assembly 100, photonic thermometer 201 is disposed directly on sheath bottom plug 102. It is contemplated that thermally conductive layer 202 can be interposed between photonic thermometer 201 and sheath bottom plug 102. Directly disposing photonic thermometer 201 on sheath bottom plug 102 can provide better thermal coupling of photonic thermometer 201 and external environment in which photonic thermometer module assembly 100 is disposed.

[0081] In an embodiment, sheath bottom plug 102 is disposed on bottom inner-wall-mount flange 120. Bottom inner-wall-mount flange 120 can be attached to bottom inner-wall-mount flange 120 as a result of being glued, welded, soldered, brazed, and the like to sheath 101. Sheath bottom plug 102 can be permanently attached to sheath 101 directly or to bottom inner-wall-mount flange 120 via welding, soldering, gluing, brazing, and the like or can be removably connected via a flange-type joint with a sealing gasket interposed between sheath bottom plug 102 and bottom inner-wall-mount flange 120.

[0082] In an embodiment, photonic thermometer module assembly 100 includes optical fiber array 301 disposed in inner volume 121 of sheath 101. Optical fiber array 301 is guided via optical fiber feedthrough 107. Optical fiber array 301 can include one optical fiber, an optical fiber bundle that includes a plurality of individual optical fibers, or an optical fiber ribbon that includes joined together optical fibers. One end of optical fiber array 301 can be connected to photonic thermometer 201 directly or via optical fiber expander 302. The other end of optical fiber array 301 can be terminated with fiber connector 303.

[0083] In an embodiment, optical fiber expander 302 can include V-shaped grooves or U-shaped grooves such as V-shape fiber groove 308 or U-shape fiber groove 309 that can be micromachined or etched in fiber expander base 306. The one-dimensional (1D) array of optical fiber array 301 can be positioned along these V-shape fiber groove 308 or U-shape fiber groove 309 as shown in FIG. 36, FIG. 37, FIG. 38, or FIG. 39. Optical fiber array 301 can be secured in

place with fiber expander cap 307, which can be attached (e.g., glued, bonded, or fused) to fiber expander base 306 (FIG. 37, FIG. 39).

[0084] In an embodiment, optical fiber expander 302 can be a multicore fiber, wherein light guiding core channels form a one-dimensional or two-dimensional array, as shown in FIG. 40 or FIG. 41. Here, optical fibers in optical fiber array 301 are arranged in fiber expander base 306. In an embodiment, optical fiber expander 302 can be in the form of a single optical fiber that is cleaved or tapered. A lens can be disposed at its terminus. In an embodiment, optical fiber expander 302 is connected to the top surface of photonic thermometer 201 (FIG. 13, FIG. 14, FIG. 15, FIG. 16, FIG. 17, FIG. 18, FIG. 19, FIG. 20, FIG. 21, or FIG. 42) via a surface grating coupler 205, e.g., light-guiding waveguide 204, that couples light from optical fiber array 301 into the on-chip integrated light-guiding waveguide 204 (FIG. 42, FIG. 43). Optical fiber expander 302 can be connected orthogonal or nearly orthogonal to the surface of photonic thermometer 201 (FIG. 42) or planar to the surface of photonic thermometer 201 (FIG. 29, FIG. 43). For the latter case, optical fiber expander 302 can have light reflecting/focusing surface 310 that reflects the light from optical fiber array 301 at an angle close to normal to the surface of photonic thermometer 201.

[0085] In an embodiment, planar coupling (FIG. 29, FIG. 43) or edge coupling (FIG. 23, FIG. 24, FIG. 25, FIG. 26, FIG. 27, FIG. 28, FIG. 44) provides a size of photonic thermometer 201 that can be accommodated in sheath bottom plug 102 that has a small diameter.

[0086] In an embodiment, optical fiber expander 302 can be connected to the polished facet of photonic thermometer 201 (FIG. 22, FIG. 23, FIG. 24, FIG. 25, FIG. 26, FIG. 27, FIG. 28), where light from optical fiber array 301 is coupled into the on-chip integrated light-guiding waveguide 204 (FIG. 44).

[0087] In an embodiment, optical fiber array 301 can be attached to photonic thermometer 201 via bonding, glass soldering, fusion, gluing with adhesives, and the like. In an embodiment, optical fiber array 301 can be connected to fiber strain relief post 304 that is disposed on heat exchanger 401 (FIG. 2, FIG. 9, FIG. 11) or on sheath bottom plug 102 (FIG. 12). Connecting optical fiber array 301 to fiber strain relief post 304 can minimize motion of optical fiber array 301 and resultingly minimize induced polarization noise, phase noise, and mode noise in photonic thermometer 201.

[0088] In an embodiment, optical fiber array 301 includes fiber splice joint 305 such that optical fiber array 301 is connected to isolated fibers embedded in top flange plug 105 (FIG. 5) or top sealing flange 104 (FIG. 7).

[0089] In an embodiment, photonic thermometer module assembly 100 includes heat exchanger 401 that is in thermal communication with photonic thermometer 201, wherein heat exchanger 401 maximizes thermal contact and thermal exchange between photonic thermometer 201 and sheath 101. Heat exchanger 401 can be made of thermally conductive materials, including metals such as copper, aluminum, metal alloys, and the like. Photonic thermometer 201 can be in direct contact with heat exchanger 401, or thermally conductive layer 202 can be interposed between photonic thermometer 201 and heat exchanger 401 (e.g., as shown in FIG. 13 to FIG. 31). Thermally conductive layer 202 increases thermal contact between photonic thermometer 201 and heat exchanger 401. Thermally conductive layer

202 can be a thermal grease, thermally conductive epoxy, polymeric material with high thermal conductivity, and the like. Thermally conductive layer **202** can be an adhesive medium (e.g., it can be a thermally conductive epoxy) that secures photonic thermometer **201** to heat exchanger **401** or sheath bottom plug **102**.

[0090] In an embodiment, photonic thermometer **201** can be attached to heat exchanger **401** via chip clamp **203** (FIG. 35). Chip clamp **203** can be fastened to heat exchanger **401** via a fastener such as screws and the like.

[0091] In an embodiment, heat exchanger **401** includes heat exchanger cavity **406** or air escape trench **402**. The number of heat exchanger cavity **406** or air escape trench **402** can be selected based on size constraints or use case. Air escape trench **402** provides a path for air to escape from sheath **101** when heat exchanger **401** and photonic thermometer **201** are disposed in sheath **101**, which is sealed at second end **109** with sheath bottom plug **102**. Additionally, air escape trench **402** increases the rate of gas evacuation of inner volume **121** of sheath **101** when photonic thermometer **201** is loaded into inner volume **121**.

[0092] In an embodiment, heat exchanger **401** is in thermal communication with sheath bottom plug **102** directly or via bottom plug thermally conductive layer **409** (e.g., as shown in FIG. 13 to FIG. 31). Bottom plug thermally conductive layer **409** increases thermal contact between heat exchanger **401** and sheath bottom plug **102**. Bottom plug thermally conductive layer **409** can be a thermal grease, thermally conductive epoxy, polymeric material with high thermal conductivity, and the like. Bottom plug thermally conductive layer **409** can be an adhesive medium (e.g., a thermally conductive epoxy) that secures heat exchanger **401** to sheath bottom plug **102**.

[0093] In an embodiment, heat exchanger **401** is disposed on sheath bottom plug **102** via bottom plug thermally conductive layer **409** (FIG. 12, FIG. 14, FIG. 17, FIG. 18, FIG. 19, FIG. 21, FIG. 22, FIG. 23, FIG. 24, FIG. 29, FIG. 30, FIG. 31), heat exchanger-to-bottom plug threaded lock joint **403** (FIG. 15, FIG. 25), magnetic force generated by permanent heat exchanger magnet **404** and bottom plug magnet **405** (FIG. 16, FIG. 17, FIG. 18, FIG. 26, FIG. 27, FIG. 28). Permanent magnets (heat exchanger magnet **404** and bottom plug magnet **405**) can be embedded in heat exchanger **401** and sheath bottom plug **102**, respectively. If heat exchanger **401** or sheath bottom plug **102** is made out of magnetic material such as stainless steel, only one magnet can be used, e.g., heat exchanger magnet **404** (FIG. 18, FIG. 27) or bottom plug magnet **405** (FIG. 17, FIG. 28). Furthermore, one magnet (heat exchanger magnet **404** or bottom plug magnet **405**) can be used when heat exchanger **401** or sheath bottom plug **102** are non-magnetic but include an embedded magnetic material.

[0094] In an embodiment, heat exchanger **401** is connected to sheath bottom plug **102** via conical self-aligning heat exchanger-to-bottom plug joint **407** (FIG. 19, FIG. 20, FIG. 23). Conical self-aligning heat exchanger-to-bottom plug joint **407** aligns heat exchanger **401** and sheath bottom plug **102** to provide a larger contact area between heat exchanger **401** and conical self-aligning heat exchanger-to-bottom plug joint **407** to increase heat transfer between heat exchanger **401** and sheath bottom plug **102**. When heat exchanger **401** has conical self-aligning heat exchanger-to-bottom plug joint **407**, heat exchanger **401** can include air escape inner channel **408** (FIG. 19, FIG. 20). Air escape

inner channel **408** allows air between heat exchanger **401** and sheath bottom plug **102** to escape from therebetween while disposing heat exchanger **401** in sheath **101**. Air escape inner channel **408** increases the rate at inner volume **121** can be evacuated while heat exchanger **401** and photonic thermometer **201** are disposed therein.

[0095] In an embodiment, heat exchanger **401** can be mechanically engaged by inner wall of sheath **101** via sheath crimp indentation **116** (FIG. 14, FIG. 24).

[0096] In an embodiment, heat exchanger **401** includes heat exchanger cavity **406** (FIG. 21, FIG. 30, FIG. 31), wherein heat exchanger cavity **406** reduces the thermal mass of heat exchanger **401** and provides a faster response time of photonic thermometer **201** to temperature variations.

[0097] In an embodiment, photonic thermometer module assembly **100** includes thermal shield **410** to shield photonic thermometer **201**. Thermal shield **410** can be made from thermally conductive materials, such as a metal or metal alloy. Thermal shield **410** can be mounted directly over photonic thermometer **201** and surrounds photonic thermometer **201** to block undesired radiation from heating or cooling photonic thermometer **201**. It should be appreciated that while thermal shield **410** blocks radiation from being received by photonic thermometer **201** from its surfaces that would (if not for thermal shield **410**) otherwise be exposed to top sealing flange **104** or inner wall of sheath **101**, thermal shield **410** does not interfere with thermal communication between photonic thermometer **201** and heat exchanger **401**.

[0098] In an embodiment, photonic thermometer module assembly **100** includes a set of baffles as baffle disk **411** disposed in sheath **101**. The baffles **411** can be supported by fiber strain relief post **304** or can be suspended from top sealing flange **104** to reduce thermal convection in inner volume **121** of sheath **101**. Baffles **411** can be disks with diameters slightly less than the inner diameter of sheath **101**. Baffles **411** can have a slot or thru-hole to allow optical fiber array **301** to extend from first end **108** of sheath **101** to photonic thermometer **201** at second end **109** of sheath **101**. Baffles **411** can be made of a material with low thermal conductivity such as glass. Baffles **411** reduce thermal convection in inner volume **121**, e.g., in an axial direction of sheath **101** along length **L**.

[0099] In an embodiment, fiber strain relief post **304** and baffles **411** decrease movement of optical fiber array **301** disposed in sheath **101** and decrease strain induced polarization, phase, or mode noise sensed by photonic thermometer **201**.

[0100] An exemplary photonic thermometer **201** is that of a high-resolution photonic thermometer article, its operation and fabrication, as well as performing high-resolution thermometry U.S. Pat. No. 10,955,617 as described in U.S. Pat. No. 10,955,617, which is incorporated herein by reference in its entirety. In particular, in U.S. Pat. No. 10,955,617, FIGS. 17-19 show a high-resolution photonic thermometer article; FIG. 18 shows a zoomed view of the high-resolution photonic thermometer article shown in FIG. 17; and FIG. 19 shows a zoomed view of the high-resolution photonic thermometer article shown in FIG. 17. A process for performing high-resolution thermometry is shown in U.S. Pat. No. 10,955,617, e.g., in FIG. 22 and FIG. 23 and corresponding detailed description.

[0101] An inert gas can be disposed in inner volume **121** of sheath **101** and can include He, Ar, Ne, Xe, Kr, Rn, and

the like. Moreover, the inert gas acts as a heat conductive media between photonic thermometer 201 and heat exchanger 401.

[0102] Photonic thermometer module assembly 100 can be made in various ways. It should be appreciated that photonic thermometer module assembly 100 includes a number of optical, electrical, or mechanical components, wherein such components can be interconnected and placed in communication (e.g., optical communication, electrical communication, mechanical communication, and the like) by physical, chemical, optical, or free-space interconnects. The components can be disposed on mounts that can be disposed on a bulkhead for alignment or physical compartmentalization. As a result, photonic thermometer module assembly 100 can be disposed in a terrestrial environment or space environment. According to an embodiment, the elements of photonic thermometer module assembly 100 are formed by additive or subtractive manufacturing.

[0103] In an embodiment, a process for making photonic thermometer module assembly 100 includes: attaching sheath bottom plug 102 to sheath 101 (e.g., by welding, brazing, soldering, gluing, and the like); attaching sheath top flange 103 to sheath 101 (e.g., by welding, brazing, soldering, gluing, and the like); attaching flanged tee-coupler 110 to sheath top flange 103 (e.g., by a vacuum-compatible sealing gasket, clamp, bolt, and the like); attaching vacuum valve 112 to flanged tee-coupler 110 (e.g., by a vacuum-compatible sealing gasket, clamp, bolt, and the like); attaching top sealing flange 104 to flanged tee-coupler 110 (e.g., by a vacuum-compatible sealing gasket, clamp, bolt, and the like). If flanged tee-coupler 110 or vacuum valve 112 are absent from photonic thermometer module assembly 100, top sealing flange 104 can be attached directly to sheath top flange 103. The process for making photonic thermometer module assembly 100 can include aligning optical fiber array 301 terminated with optical fiber expander 302 relative to photonic thermometer 201 so that light is coupled from optical fiber array 301 into light-guiding waveguide 204 on photonic thermometer 201. The process for making photonic thermometer module assembly 100 can include attaching optical fiber expander 302 relative to photonic thermometer 201 (e.g., by bonding, fusing, gluing, glass soldering, and the like); attaching fiber strain relief post 304 to heat exchanger 401 (e.g., by soldering, welding, brazing, bonding, gluing, mechanical threading, and the like). The process for making photonic thermometer module assembly 100 can include attaching baffles 411 to fiber strain relief post 304 (e.g., by crimping, bonding, gluing, and the like). The process for making photonic thermometer module assembly 100 can include disposing photonic thermometer 201 on heat exchanger 401 so that photonic thermometer 201 and heat exchanger 401 are in thermal communication; and optionally interposing thermally conductive layer 202 between photonic thermometer 201 and heat exchanger 401. The process for making photonic thermometer module assembly 100 can include fastening photonic thermometer 201 to heat exchanger 401 by chip clamp 203 or other ways such as by glue, solder, fusion, bonding, and the like. The process for making photonic thermometer module assembly 100 can include attaching optical fiber array 301 to fiber strain relief post 304 (e.g., by via bonding, gluing, fusing, soldering, and the like). To include baffles 411, the process for making photonic thermometer module assembly 100 can include guiding optical fiber array 301 via baffles 411.

[0104] The process for making photonic thermometer module assembly 100 can include moving the combination of photonic thermometer 201 and heat exchanger 401 through top sealing flange aperture 117, top sealing flange 104, flanged tee-coupler 110, and sheath top flange 103 at first end 108 of sheath 101 second end 109 of sheath 101 to sheath bottom plug 102 so that heat exchanger 401 contacts sheath bottom plug 102. The process can include inserting baffles 411 into sheath 101. The process for making photonic thermometer module assembly 100 can include attaching the combination of photonic thermometer 201 and heat exchanger 401 to sheath bottom plug 102 via heat exchanger-to-bottom plug threaded lock joint 403 (e.g., by matching machine threads, permanent magnets such as heat exchanger magnet 404 or bottom plug magnet 405, conical self-aligning heat exchanger-to-bottom plug joint 407, sheath crimp indentation 116, glue, and the like). A thermally conductive layer such as bottom plug thermally conductive layer 409 can be placed between heat exchanger 401 and sheath bottom plug 102. Bottom plug thermally conductive layer 409 can be an adhesive medium that adheres heat exchanger 401 and sheath bottom plug 102.

[0105] The process for making photonic thermometer module assembly 100 can include disposing an end of optical fiber array 301 through optical fiber feedthrough 107 in top flange plug 105 or in top sealing flange 104. Loose connecting ends of optical fiber array 301 can be spliced together at fiber splice joint 305.

[0106] The process for making photonic thermometer module assembly 100 can include disposing top flange plug 105 on top sealing flange aperture 117; and sealing gaps between top flange plug 105 and top sealing flange 104. If top sealing flange 104 is used without including top sealing flange aperture 117, the process can include attaching top sealing flange 104 to flanged tee-coupler 110 or to sheath top flange 103 (if flanged tee-coupler 110 is omitted from photonic thermometer module assembly 100), wherein top sealing flange 104 can be attached with a vacuum-compatible gasket, clamp, bolts, and the like. The process can include attaching optical fiber support collar 114 to top sealing flange 104; positioning optical fiber array 301 along optical fiber support fin 115 to avoid fiber bending that could result in damage to optical fibers; evacuating inner volume 121 of sheath 101 by exchange gas evacuation/filling tube 106 or vacuum valve 112; optionally filling inner volume 121 of sheath 101 with an inert gas to a selected, e.g., from 1 Pa to 100 kPa; sealing exchange gas evacuation/filling tube 106 (e.g., by soldering, gluing, welding, crimping, cold fusion, and the like), closing vacuum valve 112; sealing vacuum valve 112 with vacuum valve plug 113.

[0107] In an embodiment, a process for making photonic thermometer module assembly 100 with a capsular format, e.g., as shown in FIG. 12, having minimal length L of sheath 101 includes: attaching bottom inner-wall-mount flange 120 to sheath 101 (e.g., by welding, brazing, soldering, gluing, and the like); attaching top inner-wall-mount flange 118 to sheath 101 (e.g., by welding, brazing, soldering, gluing, and the like); attaching top seal plug 119 to sheath 101 (e.g., directly by via welding, brazing, soldering, gluing, and the like or indirectly via top inner-wall-mount flange 118), wherein the connection between top seal plug 119 and top inner-wall-mount flange 118 can be made by gluing, soldering, welding, brazing, or a sealing gasket interposed between top seal plug 119 and top inner-wall-mount flange

118. Top seal plug **119** can be configured with exchange gas evacuation/filling tube **106**, optical fiber feedthrough **107**, and optical fiber array **301** that is guided through optical fiber feedthrough **107**. Optical fiber array **301** can have a bare terminus or can be terminated with optical fiber expander **302**. The process can include: aligning optical fiber array **301** terminated with optical fiber expander **302** relative to photonic thermometer **201** so that light is coupled from optical fiber array **301** into light-guiding waveguide **204** on photonic thermometer **201**; attaching optical fiber expander **302** to photonic thermometer **201** (e.g., by bonding, fusing, gluing, glass soldering, and the like); attaching photonic thermometer **201** to sheath bottom plug **102**; optionally interposing thermally conductive layer **202** between photonic thermometer **201** and heat exchanger **401**, wherein photonic thermometer **201** is optionally secured relative to sheath bottom plug **102** by chip clamp **203**, glue, solder, fusion, bonding, and the like; attaching optical fiber array **301** to fiber strain relief post **304** (e.g., by bonding, gluing, fusing, soldering, and the like); optionally (if optical fiber feedthrough **107** is disposed in optical fiber feedthrough **107** with a bare terminus) attaching free ends of optical fiber array **301** at fiber splice joint **305** by fusion splicing, and the like; evacuating inner volume **121** of sheath **101** through exchange gas evacuation/filling tube **106**; optionally filling inner volume **121** of sheath **101** with an inert gas to a selected pressure; and sealing exchange gas evacuation/filling tube **106** (e.g., by soldering, gluing, welding, crimping, cold fusion, and the like).

[0108] Photonic thermometer module assembly **100** has numerous advantageous and unexpected benefits and uses. In an embodiment, a process for performing photonic thermometry includes: evacuating inner volume **121** of sheath **101** via vacuum valve **112**, or exchange gas evacuation/filling tube **106** (and sealing exchange gas evacuation/filling tube **106** after its use); flushing inner volume **121** with inert gas by sequential cycles of purging with inert gas followed by evacuating inner volume **121**; optionally heating photonic thermometer module assembly **100** from 40° C. to 150° C. while vacuum pumping to remove water vapor from inner volume **121**; maintaining a vacuum pressure in inner volume **121** or filling inner volume **121** with an inert gas to a selected pressure to thermally stabilize photonic thermometer **201** relative to the external environment at exterior **122**; closing vacuum valve **112**; attaching vacuum valve plug **113**; sealing exchange gas evacuation/filling tube **106** if gas filling occurred via exchange gas evacuation/filling tube **106**; determining temperature with photonic thermometer **201**, e.g., using procedures described in U.S. Pat. No. 10,955,617, which is incorporated by reference herein in its entirety.

[0109] While one or more embodiments have been shown and described, modifications and substitutions may be made thereto without departing from the spirit and scope of the invention. Accordingly, it is to be understood that the present invention has been described by way of illustrations and not limitation. Embodiments herein can be used independently or can be combined.

[0110] All ranges disclosed herein are inclusive of the endpoints, and the endpoints are independently combinable with each other. The ranges are continuous and thus contain every value and subset thereof in the range. Unless otherwise stated or contextually inapplicable, all percentages, when expressing a quantity, are weight percentages. The

suffix (s) as used herein is intended to include both the singular and the plural of the term that it modifies, thereby including at least one of that term (e.g., the colorant(s) includes at least one colorants). Option, optional, or optionally means that the subsequently described event or circumstance can or cannot occur, and that the description includes instances where the event occurs and instances where it does not. As used herein, combination is inclusive of blends, mixtures, alloys, reaction products, collection of elements, and the like.

[0111] As used herein, a combination thereof refers to a combination comprising at least one of the named constituents, components, compounds, or elements, optionally together with one or more of the same class of constituents, components, compounds, or elements.

[0112] All references are incorporated herein by reference.

[0113] The use of the terms “a,” “an,” and “the” and similar referents in the context of describing the invention (especially in the context of the following claims) are to be construed to cover both the singular and the plural, unless otherwise indicated herein or clearly contradicted by context. It can further be noted that the terms first, second, primary, secondary, and the like herein do not denote any order, quantity, or importance, but rather are used to distinguish one element from another. It will also be understood that, although the terms first, second, etc. are, in some instances, used herein to describe various elements, these elements should not be limited by these terms. For example, a first current could be termed a second current, and, similarly, a second current could be termed a first current, without departing from the scope of the various described embodiments. The first current and the second current are both currents, but they are not the same condition unless explicitly stated as such.

[0114] The modifier “about” used in connection with a quantity is inclusive of the stated value and has the meaning dictated by the context (e.g., it includes the degree of error associated with measurement of the particular quantity). The conjunction “or” is used to link objects of a list or alternatives and is not disjunctive; rather the elements can be used separately or can be combined together under appropriate circumstances.

What is claimed is:

1. A photonic thermometer module assembly for performing photonic thermometry, the photonic thermometer module assembly comprising:

- a sheath comprising an inner volume, a first end, and a second end disposed at an opposite end of the sheath than the first end;
- a sheath bottom plug disposed on the sheath at the second end such that the sheath bottom plug hermetically seals the sheath at the second end;
- a sheath top flange disposed at the first end;
- a top sealing flange disposed on the sheath top flange at the first end such that the top sealing flange hermetically seals the sheath at the first end;
- a heat exchanger disposed on the sheath bottom plug such that the heat exchanger is in thermal communication with the sheath bottom plug;
- a photonic thermometer disposed on the heat exchanger such that: the photonic thermometer is in thermal communication with the sheath bottom plug through the heat exchanger; the heat exchanger is interposed between the photonic thermometer and the photonic

- thermometer, and the photonic thermometer determines a temperature of the sheath; and
- an optical fiber array in optical communication with the photonic thermometer and that optically couples the photonic thermometer to an exterior environment of the photonic thermometer module assembly,
- wherein the photonic thermometer module assembly is compatible with International Temperature Scale of 1990 (ITS-90) fixed-point cell infrastructure and conventional drywell and oil-bath calibrations, and the photonic thermometer module assembly provides temperature measurements from -200° C. to $+700^{\circ}$ C.
2. The photonic thermometer module assembly of claim 1, wherein wherein the heat exchanger and the photonic thermometer are individual modules that are mechanically robust and reconfigurable, and provide independent and separate replacement of the heat exchanger or the photonic thermometer.
 3. The photonic thermometer module assembly of claim 1, further comprising a flanged tee-coupler interposed between the sheath top flange and the top sealing flange.
 4. The photonic thermometer module assembly of claim 3, further comprising a vacuum valve disposed on the flanged tee-coupler.
 5. The photonic thermometer module assembly of claim 4, further comprising a vacuum valve plug disposed on the vacuum valve, such that the vacuum valve is interposed between the flanged tee-coupler and the vacuum valve plug.
 6. The photonic thermometer module assembly of claim 1, further comprising an optical fiber feedthrough disposed on the top sealing flange such that the optical fiber array is communicated through the optical fiber feedthrough from the inner volume of the sheath to the exterior environment of the photonic thermometer module assembly.
 7. The photonic thermometer module assembly of claim 1, further comprising an exchange gas evacuation/filling tube disposed on the top sealing flange such that the exchange gas evacuation/filling tube is in fluid communication with the inner volume of the sheath and provides fluid evacuation or fluid introduction to the inner volume.
 8. The photonic thermometer module assembly of claim 1, further comprising a top flange plug disposed on the top sealing flange such that top sealing flange is interposed between the sheath and the top flange plug, and the sheath top flange, the top sealing flange, and the top flange plug hermetically seal the photonic thermometer module assembly at the first end of the second end.
 9. The photonic thermometer module assembly of claim 8, further comprising an optical fiber feedthrough disposed on the top flange plug such that the optical fiber array is communicated through the optical fiber feedthrough from the inner volume of the sheath to the exterior environment of the photonic thermometer module assembly.
 10. The photonic thermometer module assembly of claim 8, further comprising an exchange gas evacuation/filling tube disposed on the top flange plug such that the exchange gas evacuation/filling tube is in fluid communication with the inner volume of the sheath and provides fluid evacuation or fluid introduction to the inner volume.
 11. The photonic thermometer module assembly of claim 1, further comprising an optical fiber support collar disposed on the top sealing flange; and an optical fiber support fin disposed on the optical fiber support collar such that the

optical fiber array is mechanically supported by the optical fiber support fin to avoid strain on the optical fiber array.

12. The photonic thermometer module assembly of claim 1, further comprising a fiber strain relief post disposed on the heat exchanger such that the optical fiber array is mechanically supported by the fiber strain relief post to avoid strain on the optical fiber array.
13. The photonic thermometer module assembly of claim 1, further comprising a thermally conductive layer interposed between the sheath bottom plug and the photonic thermometer to provide thermal communication from the sheath bottom plug to the photonic thermometer.
14. The photonic thermometer assembly of claim 1, further comprising bottom plug thermally conductive layer to provide thermal communication from the heat exchanger to the sheath bottom plug.
15. The photonic thermometer module assembly of claim 1, further comprising an optical fiber expander optically interposed between the optical fiber array and the photonic thermometer to provide optical communication from the optical fiber array to the photonic thermometer.
16. The photonic thermometer module assembly of claim 1, further comprising a baffle disposed in the inner volume of the sheath such that the baffle is interposed between the top sealing flange and the photonic thermometer, and the baffle reduces thermal convection in the inner volume.
17. The photonic thermometer module assembly of claim 1, further comprising a thermal shield disposed in the inner volume and disposed on the photonic thermometer such that the thermal shield blocks photonic thermometer from temperature gradients and temperature fluctuations in the inner volume and maintains sensitivity of the photonic thermometer to the temperature of the heat exchanger.
18. The photonic thermometer module assembly of claim 1, wherein a length L of the sheath from the first end to the distal-most surface of the sheath bottom plug is from 1 cm to 60 cm.
19. A photonic thermometer module assembly for performing photonic thermometry, the photonic thermometer module assembly comprising:
 - a sheath comprising an inner volume, a first end, and a second end disposed at an opposite end of the sheath than the first end;
 - a sheath bottom plug disposed on the sheath at the second end such that the sheath bottom plug hermetically seals the sheath at the second end;
 - a top inner-wall-mount flange disposed at the first end;
 - a top seal plug disposed on the top inner-wall-mount flange at the first end such that the top seal plug hermetically seals the sheath at the first end;
 - a heat exchanger disposed on the sheath bottom plug such that the heat exchanger is in thermal communication with the sheath bottom plug;
 - a photonic thermometer disposed on the heat exchanger such that: the photonic thermometer is in thermal communication with the sheath bottom plug through the heat exchanger; the heat exchanger is interposed between the photonic thermometer and the photonic thermometer, and the photonic thermometer determines a temperature of the sheath; and
 - an optical fiber array in optical communication with the photonic thermometer and that optically couples the photonic thermometer to an exterior environment of the photonic thermometer module assembly,

wherein the photonic thermometer module assembly is compatible with International Temperature Scale of 1990 (ITS-90) fixed-point cell infrastructure and conventional drywell and oil-bath calibrations, and the photonic thermometer module assembly provides temperature measurements from -200°C . to $+700^{\circ}\text{C}$.

20. The photonic thermometer module assembly of claim **19**, further comprising an optical fiber feedthrough disposed on the top seal plug such that the optical fiber array is communicated through the optical fiber feedthrough from the inner volume of the sheath to the exterior environment of the photonic thermometer module assembly.

21. The photonic thermometer module assembly of claim **19**, further comprising an exchange gas evacuation/filling tube disposed on the top seal plug such that the exchange gas evacuation/filling tube is in fluid communication with the inner volume of the sheath and provides fluid evacuation or fluid introduction to the inner volume.

22. The photonic thermometer module assembly of claim **19**, further comprising a fiber strain relief post disposed on the heat exchanger such that the optical fiber array is mechanically supported by the fiber strain relief post to avoid strain on the optical fiber array.

23. The photonic thermometer module assembly of claim **19**, further comprising a thermally conductive layer interposed between the sheath bottom plug and the photonic thermometer to provide thermal communication from the sheath bottom plug to the photonic thermometer.

24. The photonic thermometer module assembly of claim **19**, further comprising an optical fiber expander optically interposed between the optical fiber array and the photonic thermometer to provide optical communication from the optical fiber array to the photonic thermometer.

25. The photonic thermometer module assembly of claim **1**, wherein a length L of the sheath from the first end to the distal-most surface of the sheath bottom plug is from 1 cm to 60 cm.

* * * * *