

Table of Contents

Teaching and Learning The Metric System	
Unit 1	1
- Suggested Teaching Sequence	1
- Objectives	1
- Rules of Notation	1
- Metric Units, Symbols, and Referents	2
- Metric Prefixes	2
- Linear Measurement Activities	3
- Area Measurement Activities	5
- Volume Measurement Activities	7
- Mass (Weight) Measurement Activities	9
- Temperature Measurement Activities	11
Unit 2	12
- Objectives	12
- Suggested Teaching Sequence	12
- Metrics in this Occupation	12
- Metric Units For Plumbing and Pipefitting	13
- Trying Out Metric Units	14
- Plumbing and Fitting With Metrics	15
- Metric Piping Dimensions	16
Unit 3	17
- Objective	17
- Suggested Teaching Sequence	17
- Metric-Metric Equivalents	17
- Changing Units at Work	19
Unit 4	20
- Objective	20
- Suggested Teaching Sequence	20
- Selecting and Using Metric Instruments, Tools and Devices	20
- Which Tools for the Job?	21
- Measuring Up in Pipe Fitting	21
Unit 5	22
- Objective	22
- Suggested Teaching Sequence	22
- Metric-Customary Equivalents	22
- Conversion Tables	23
- Any Way You Want It	24
Testing Metric Abilities	25
Answers to Exercises and Test	27
Tools and Devices List	
References	

metrics for metrics for
for metrics for metrics
metrics for metrics for
for metrics for metrics
metrics for metrics for
for metrics for metrics
metrics for metrics for
for metrics for metrics
metrics for metrics for
for metrics **metrics for**
plumbing , pipefitting
for metrics for metrics
metrics for metrics for



TEACHING AND LEARNING THE METRIC SYSTEM

This metric instructional package was designed to meet job-related metric measurement needs of students. To use this package students should already know the occupational terminology, measurement terms, and tools currently in use. These materials were prepared with the help of experienced vocational teachers, reviewed by experts, tested in classrooms in different parts of the United States, and revised before distribution.

Each of the five units of instruction contains performance objectives, learning activities, and supporting information in the form of text, exercises, and tables. In addition, suggested teaching techniques are included. At the back of this package are objective-based evaluation items, a page of answers to the exercises and tests, a list of metric materials needed for the activities, references, and a list of suppliers.

Classroom experiences with this instructional package suggest the following teaching-learning strategies:

1. Let the first experiences be informal to make learning the metric system fun.
2. Students learn better when metric units are compared to familiar objects. Everyone should learn to "think metric." Comparing metric units to customary units can be confusing.
3. Students will learn quickly to estimate and measure in metric units by "doing."
4. Students should have experience with measuring activities before getting too much information.
5. Move through the units in an order which emphasizes the simplicity of the metric system (e.g., length to area to volume).
6. Teach one concept at a time to avoid overwhelming students with too much material.

Unit 1 is a general introduction to the metric system of measurement which provides informal, hands-on experiences for the students. This unit enables students to become familiar with the basic metric units, their symbols, and measurement instruments; and to develop a set of mental references for metric values. The metric system of notation also is explained.

Unit 2 provides the metric terms which are used in this occupation and gives experience with occupational measurement tasks.

Unit 3 focuses on job-related metric equivalents and their relationships.

Unit 4 provides experience with recognizing and using metric instruments and tools in occupational measurement tasks. It also provides experience in comparing metric and customary measurement instruments.

Unit 5 is designed to give students practice in converting customary and metric measurements. Students should learn to "think metric" and avoid comparing customary and metric units. However, skill with conversion tables will be useful during the transition to metric in each occupation.

Using These Instructional Materials

This package was designed to help students learn a core of knowledge about the metric system which they will use on the job. The exercises facilitate experiences with measurement instruments, tools, and devices used in this occupation and job-related tasks of estimating and measuring.

This instructional package also was designed to accommodate a variety of individual teaching and learning styles. Teachers are encouraged to adapt these materials to their own classes. For example, the information sheets may be given to students for self-study. References may be used as supplemental resources. Exercises may be used in independent study, small groups, or whole-class activities. All of the materials can be expanded by the teacher.

Gloria S. Cooper
Joel H. Magisos
Editors

This publication was developed pursuant to contract No. OEC-0-74-9335 with the Bureau of Occupational and Adult Education, U.S. Department of Health, Education and Welfare. However, the opinions expressed herein do not necessarily reflect the position or policy of the U.S. Office of Education and no official endorsement by the U.S. Office of Education should be inferred.

UNIT 1

SUGGESTED TEACHING SEQUENCE

1. These introductory exercises may require two or three teaching periods for all five areas of measurement.
2. Exercises should be followed in the order given to best show the relationship between length, area, and volume.
3. Assemble the metric measuring devices (rules, tapes, scales, thermometers, and measuring containers) and objects to be measured.*
4. Set up the equipment at work stations for use by the whole class or as individualized resource activities.
5. Have the students estimate, measure, and record using Exercises 1 through 5.
6. Present information on notation and make Table 1 available.
7. Follow up with group discussion of activities.

*Other school departments may have devices which can be used. Metric suppliers are listed in the reference section.

OBJECTIVES

The student will demonstrate these skills for the Linear, Area, Volume or Capacity, Mass, and Temperature Exercises, using the metric terms and measurement devices listed here.

SKILLS	EXERCISES				
	Linear (pp. 3 - 4)	Area (pp. 5 - 6)	Volume or Capacity (pp. 7 - 8)	Mass (pp. 9 - 10)	Temperature (p. 11)
1. Recognize and use the unit and its symbol for:	millimetre (mm)	square centimetre (cm ²)	cubic centimetre (cm ³)	gram (g)	degree Celsius (°C)
2. Select, use, and read the appropriate measuring instruments for:	centimetre (cm)	square metre (m ²)	cubic metre (m ³)	kilogram (kg)	
3. State or show a physical reference for:	metre (m)		litre (l)		
			millilitre (ml)		
4. Estimate within 25% of the actual measure	height, width, or length of objects	the area of a given surface	capacity of containers	the mass of objects in grams and kilograms	the temperature of the air or a liquid
5. Read correctly	metre stick, metric tape measure, and metric rulers		measurements on graduated volume measuring devices	a kilogram scale and a gram scale	A Celsius thermometer

RULES OF NOTATION

1. Symbols are not capitalized unless the unit is a proper name (mm *not* MM).
2. Symbols are not followed by periods (m *not* m.).
3. Symbols are not followed by an s for plurals (25 g *not* 25 gs).
4. A space separates the numerals from the unit symbols (4 l *not* 4l).
5. Spaces, not commas, are used to separate large numbers into groups of three digits (45 271 km *not* 45,271 km).
6. A zero precedes the decimal point if the number is less than one (0.52 g *not* .52 g).
7. Litre and metre can be spelled either with an -re or -er ending.

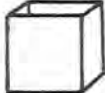

METRIC UNITS, SYMBOLS, AND REFERENTS

Quantity	Metric Unit	Symbol	Useful Referents
Length	millimetre	mm	Thickness of dime or paper clip wire
	centimetre	cm	Width of paper clip
	metre	m	Height of door about 2 m
	kilometre	km	12-minute walking distance
Area	square centimetre	cm ²	Area of this space 
	square metre	m ²	Area of card table top
	hectare	ha	Football field including sidelines and end zones
Volume and Capacity	millilitre	ml	Teaspoon is 5 ml
	litre	l	A little more than 1 quart
	cubic centimetre	cm ³	Volume of this container 
	cubic metre	m ³	A little more than a cubic yard
Mass	milligram	mg	Apple seed about 10 mg, grain of salt, 1 mg
	gram	g	Nickel about 5 g
	kilogram	kg	Webster's Collegiate Dictionary
	metric ton (1 000 kilograms)	t	Volkswagen Beetle

METRIC PREFIXES

Multiples and Submultiples	Prefixes	Symbols
1 000 000 = 10 ⁶	mega (měg'á)	M
1 000 = 10 ³	kilo (kíl'ō)	k
100 = 10 ²	hecto (hěk'tō)	h
10 = 10 ¹	deka (děk'á)	da
Base Unit 1 = 10 ⁰		
0.1 = 10 ⁻¹	deci (děš'í)	d
0.01 = 10 ⁻²	centi (sěň'tí)	c
0.001 = 10 ⁻³	milli (míl'í)	m
0.000 001 = 10 ⁻⁶	micro (mí'krō)	μ

Table 1-b

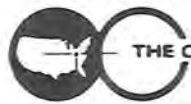

LINEAR MEASUREMENT ACTIVITIES

Metre, Centimetre, Millimetre

I. THE METRE (m)

A. DEVELOP A FEELING FOR THE SIZE OF A METRE

1. Pick up one of the metre sticks and stand it up on the floor. Hold it in place with one hand. Walk around the stick. Now stand next to the stick. With your other hand, touch yourself where the top of the metre stick comes on you.



THAT IS HOW HIGH A METRE IS!

2. Hold one arm out straight at shoulder height. Put the metre stick along this arm until the end hits the end of your fingers. Where is the other end of the metre stick? Touch yourself at that end.



THAT IS HOW LONG A METRE IS!

3. Choose a partner to stand at your side. Move apart so that you can put one end of a metre stick on your partner's shoulder and the other end on your shoulder. Look at the space between you.

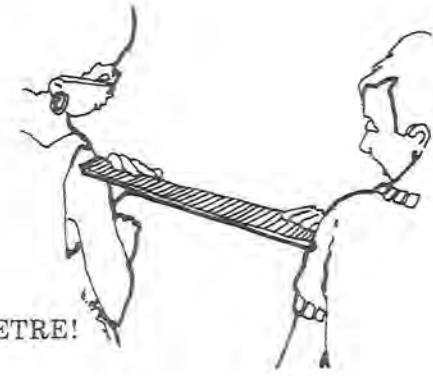

THAT IS THE WIDTH OF A METRE!

B. DEVELOP YOUR ABILITY TO ESTIMATE IN METRES

Now you will improve your ability to estimate in metres. Remember where the length and height of a metre was on your body.

For each of the following items:

Estimate the size of the items and write your estimate in the ESTIMATE column. Measure the size with your metre stick and write the answer in the MEASUREMENT column.

Decide how close your estimate was to the actual measure. If your estimate was within 25% of the actual measure you are a "Metric Marvel."

	Estimate (m)	Measurement (m)	How Close Were You?
1. Height of door knob from floor.	_____	_____	_____
2. Height of door.	_____	_____	_____
3. Length of table.	_____	_____	_____
4. Width of table.	_____	_____	_____
5. Length of wall of this room.	_____	_____	_____
6. Distance from you to wall.	_____	_____	_____

II. THE CENTIMETRE (cm)

There are 100 centimetres in one metre. If there are 4 metres and 3 centimetres, you write 403 cm [(4 x 100 cm) + 3 cm = 400 cm + 3 cm].

A. DEVELOP A FEELING FOR THE SIZE OF A CENTIMETRE

1. Hold the metric ruler against the width of your thumbnail. How wide is it? _____ cm
2. Measure your thumb from the first joint to the end. _____ cm
3. Use the metric ruler to find the width of your palm. _____ cm
4. Measure your index or pointing finger. How long is it? _____ cm
5. Measure your wrist with a tape measure. What is the distance around it? _____ cm
6. Use the tape measure to find your waist size. _____ cm

B. DEVELOP YOUR ABILITY TO ESTIMATE IN CENTIMETRES

You are now ready to estimate in centimetres. For each of the following items, follow the procedures used for estimating in metres.

	Estimate (cm)	Measurement (cm)	How Close Were You?
1. Length of a paper clip.	_____	_____	_____
2. Diameter (width) of a coin.	_____	_____	_____
3. Width of a postage stamp.	_____	_____	_____
4. Length of a pencil.	_____	_____	_____
5. Width of a sheet of paper.	_____	_____	_____

III. THE MILLIMETRE (mm)

There are 10 millimetres in one centimetre. When a measurement is 2 centimetres and 5 millimetres, you write 25 mm [(2 x 10 mm) + 5 mm = 20 mm + 5 mm]. There are 1 000 mm in 1 m.

A. DEVELOP A FEELING FOR THE SIZE OF A MILLIMETRE

Using a ruler marked in millimetres, measure:

1. Thickness of a paper clip wire. _____ mm
2. Thickness of your fingernail. _____ mm
3. Width of your fingernail. _____ mm
4. Diameter (width) of a coin. _____ mm
5. Diameter (thickness) of your pencil. _____ mm
6. Width of a postage stamp. _____ mm

B. DEVELOP YOUR ABILITY TO ESTIMATE IN MILLIMETRES

You are now ready to estimate in millimetres. For each of the following items, follow the procedures used for estimating in metres.

	Estimate (mm)	Measurement (mm)	How Close Were You?
1. Thickness of a nickel.	_____	_____	_____
2. Diameter (thickness) of a bolt.	_____	_____	_____
3. Length of a bolt.	_____	_____	_____
4. Width of a sheet of paper.	_____	_____	_____
5. Thickness of a board or desk top.	_____	_____	_____
6. Thickness of a button.	_____	_____	_____



AREA MEASUREMENT ACTIVITIES

Square Centimetre, Square Metre

WHEN YOU DESCRIBE THE AREA OF SOMETHING, YOU ARE SAYING HOW MANY SQUARES OF A GIVEN SIZE IT TAKES TO COVER THE SURFACE.

I. THE SQUARE CENTIMETRE (cm²)

A. DEVELOP A FEELING FOR A SQUARE CENTIMETRE

1. Take a clear plastic grid, or use the grid on page 6.
2. Measure the length and width of one of these small squares with a centimetre ruler.

THAT IS ONE SQUARE CENTIMETRE!

3. Place your fingernail over the grid. About how many squares does it take to cover your fingernail?
_____cm²
4. Place a coin over the grid. About how many squares does it take to cover the coin? _____cm²
5. Place a postage stamp over the grid. About how many squares does it take to cover the postage stamp?
_____cm²
6. Place an envelope over the grid. About how many squares does it take to cover the envelope?
_____cm²
7. Measure the length and width of the envelope in centimetres. Length _____ cm; width _____ cm. Multiply to find the area in square centimetres.
_____cm x _____cm = _____cm². How close are the answers you have in 6. and in 7.?

B. DEVELOP YOUR ABILITY TO ESTIMATE IN SQUARE CENTIMETRES

You are now ready to develop your ability to estimate in square centimetres.

Remember the size of a square centimetre. For each of the following items, follow the procedures used for estimating in metres.

	Estimate (cm ²)	Measurement (cm ²)	How Close Were You?
1. Index card.	_____	_____	_____
2. Book cover.	_____	_____	_____
3. Photograph.	_____	_____	_____
4. Window pane or desk top.	_____	_____	_____

II. THE SQUARE METRE (m²)

A. DEVELOP A FEELING FOR A SQUARE METRE

1. Tape four metre sticks together to make a square which is one metre long and one metre wide.
2. Hold the square up with one side on the floor to see how big it is.
3. Place the square on the floor in a corner. Step back and look. See how much floor space it covers.
4. Place the square over a table top or desk to see how much space it covers.
5. Place the square against the bottom of a door. See how much of the door it covers. How many squares would it take to cover the door? _____m²

THIS IS HOW BIG A SQUARE METRE IS!

B. DEVELOP YOUR ABILITY TO ESTIMATE IN SQUARE METRES

You are now ready to estimate in square metres. Follow the procedures used for estimating in metres.

	Estimate (m ²)	Measurement (m ²)	How Close Were You?
1. Door.	_____	_____	_____
2. Full sheet of newspaper.	_____	_____	_____
3. Chalkboard or bulletin board.	_____	_____	_____
4. Floor.	_____	_____	_____
5. Wall.	_____	_____	_____
6. Wall chart or poster.	_____	_____	_____
7. Side of file cabinet.	_____	_____	_____

CENTIMETRE GRID

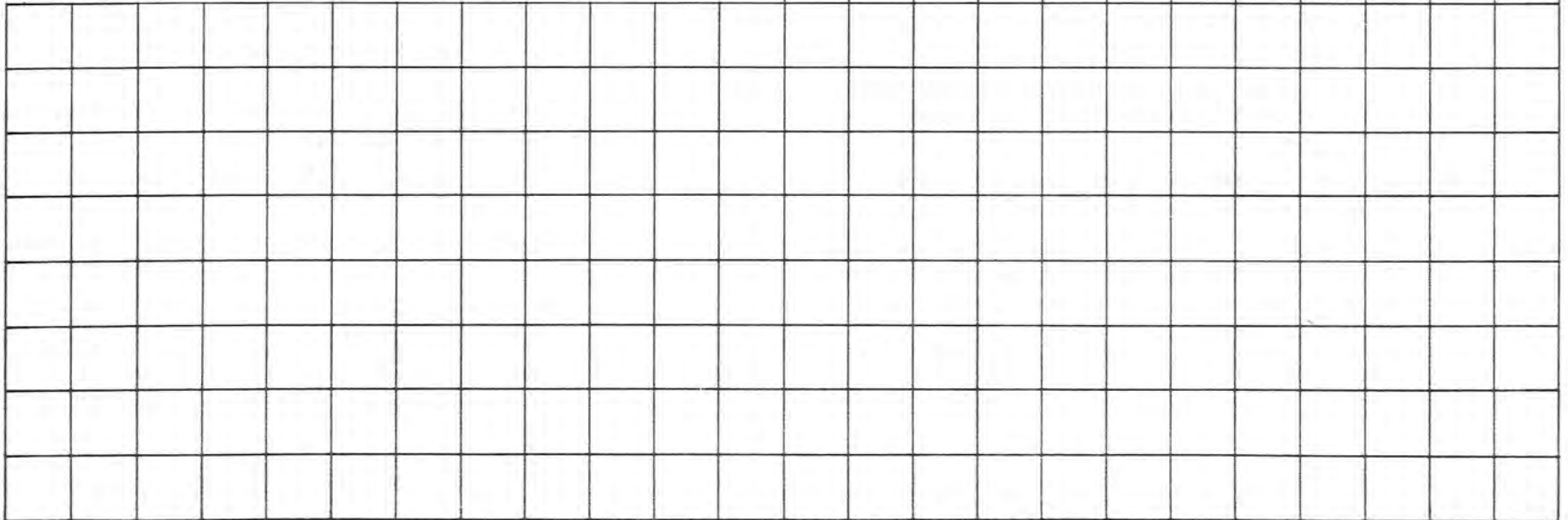
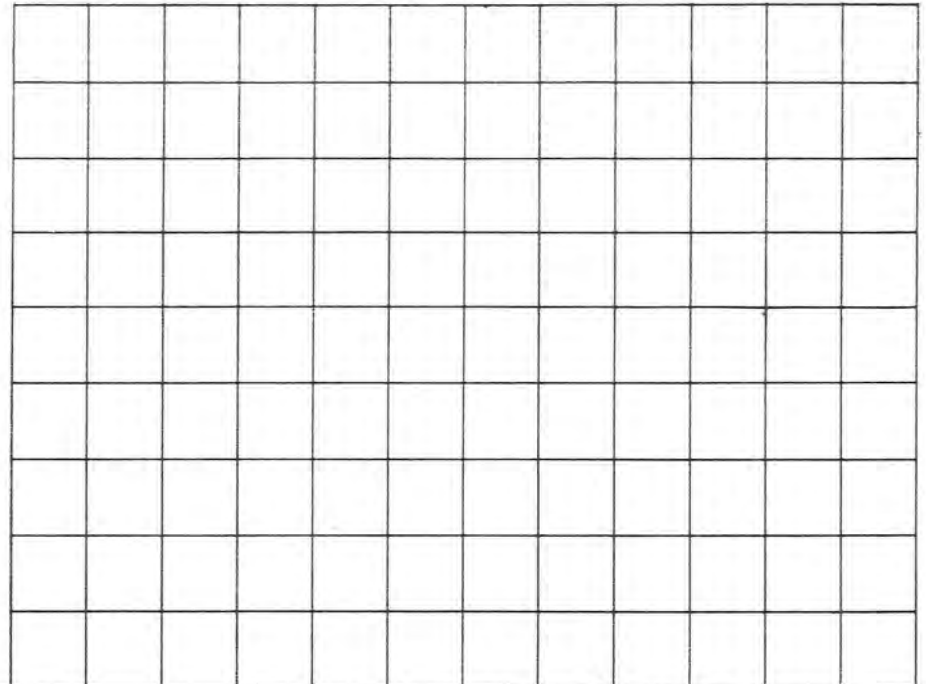

VOLUME MEASUREMENT ACTIVITIES

Cubic Centimetre, Litre, Millilitre, Cubic Metre

I. THE CUBIC CENTIMETRE (cm³)

A. DEVELOP A FEELING FOR THE CUBIC CENTIMETRE

- Pick up a colored plastic cube. Measure its length, height, and width in centimetres.

THAT IS ONE CUBIC CENTIMETRE!

- Find the volume of a plastic litre box.

- Place a ROW of cubes against the bottom of one side of the box. How many cubes fit in the row? _____

- Place another ROW of cubes against an adjoining side of the box. How many rows fit inside the box to make one layer of cubes? _____

How many cubes in each row? _____

How many cubes in the layer in the bottom of the box? _____

- Stand a ROW of cubes up against the side of the box. How many LAYERS would fit in the box? _____

How many cubes in each layer? _____

How many cubes fit in the box altogether? _____

THE VOLUME OF THE BOX IS _____ CUBIC CENTIMETRES.

- Measure the length, width, and height of the box in centimetres. Length _____ cm; width _____ cm; height _____ cm. Multiply these numbers to find the volume in cubic centimetres.

_____ cm x _____ cm x _____ cm = _____ cm³.

Are the answers the same in c. and d.?

B. DEVELOP YOUR ABILITY TO ESTIMATE IN CUBIC CENTIMETRES

You are now ready to develop your ability to estimate in cubic centimetres.

Remember the size of a cubic centimetre. For each of the following items, use the procedures for estimating in metres.

	Estimate (cm ³)	Measurement (cm ³)	How Close Were You?
1. Index card file box.	_____	_____	_____
2. Freezer container.	_____	_____	_____
3. Paper clip box.	_____	_____	_____
4. Box of staples.	_____	_____	_____

II. THE LITRE (l)

A. DEVELOP A FEELING FOR A LITRE

- Take a one litre beaker and fill it with water.
- Pour the water into paper cups, filling each as full as you usually do. How many cups do you fill?

THAT IS HOW MUCH IS IN ONE LITRE!

- Fill the litre container with rice.

THAT IS HOW MUCH IT TAKES TO FILL A ONE LITRE CONTAINER!



B. DEVELOP YOUR ABILITY TO ESTIMATE IN LITRES

You are now ready to develop your ability to estimate in litres. To write two and one-half litres, you write 2.5 l, or 2.5 litres. To write one-half litre, you write 0.5 l, or 0.5 litre. To write two and three-fourths litres, you write 2.75 l, or 2.75 litres.

For each of the following items, use the procedures for estimating in metres.

	Estimate (l)	Measurement (l)	How Close Were You?
1. Medium-size freezer container.	_____	_____	_____
2. Large freezer container.	_____	_____	_____
3. Small freezer container.	_____	_____	_____
4. Bottle or jug.	_____	_____	_____

III. THE MILLILITRE (ml)

There are 1 000 millilitres in one litre. 1 000 ml = 1 litre. Half a litre is 500 millilitres, or 0.5 litre = 500 ml.

A. DEVELOP A FEELING FOR A MILLILITRE

1. Examine a centimetre cube. Anything which holds 1 cm³ holds 1 ml.
2. Fill a 1 millilitre measuring spoon with rice. Empty the spoon into your hand. Carefully pour the rice into a small pile on a sheet of paper.

THAT IS HOW MUCH ONE MILLILITRE IS!

3. Fill the 5 ml spoon with rice. Pour the rice into another pile on the sheet of paper.

THAT IS 5 MILLILITRES, OR ONE TEASPOON!

4. Fill the 15 ml spoon with rice. Pour the rice into a third pile on the paper.

THAT IS 15 MILLILITRES, OR ONE TABLESPOON!

B. DEVELOP YOUR ABILITY TO ESTIMATE IN MILLILITRES

You are now ready to estimate in millilitres. Follow the procedures used for estimating metres.

	Estimate (ml)	Measurement (ml)	How Close Were You?
1. Small juice can.	_____	_____	_____
2. Paper cup or tea cup.	_____	_____	_____
3. Soft drink can.	_____	_____	_____
4. Bottle.	_____	_____	_____

IV. THE CUBIC METRE (m³)

A. DEVELOP A FEELING FOR A CUBIC METRE

1. Place a one metre square on the floor next to the wall.
2. Measure a metre UP the wall.
3. Picture a box that would fit into that space.
THAT IS THE VOLUME OF ONE CUBIC METRE!

B. DEVELOP YOUR ABILITY TO ESTIMATE IN CUBIC METRES

For each of the following items, follow the estimating procedures used before.

	Estimate (m ³)	Measurement (m ³)	How Close Were You?
1. Office desk.	_____	_____	_____
2. File cabinet.	_____	_____	_____
3. Small room.	_____	_____	_____

MASS (WEIGHT) MEASUREMENT ACTIVITIES

Kilogram, Gram

The mass of an object is a measure of the amount of matter in the object. This amount is always the same unless you add or subtract some matter from the object. Weight is the term that most people use when they mean mass. The weight of an object is affected by gravity; the mass of an object is not. For example, the weight of a person on earth might be 120 pounds; that same person's weight on the moon would be 20 pounds. This difference is because the pull of gravity on the moon is less than the pull of gravity on earth. A person's mass on the earth and on the moon would be the same. The metric system does not measure weight--it measures mass. We will use the term mass here.

The symbol for gram is g.

The symbol for kilogram is kg.

There are 1 000 grams in one kilogram, or $1\ 000\text{ g} = 1\text{ kg}$.

Half a kilogram can be written as 500 g, or 0.5 kg.

A quarter of a kilogram can be written as 250 g, or 0.25 kg.

Two and three-fourths kilograms is written as 2.75 kg.

I. THE KILOGRAM (kg)

DEVELOP A FEELING FOR THE MASS OF A KILOGRAM

Using a balance or scale, find the mass of the items on the table. Before you find the mass, notice how heavy the object "feels" and compare it to the reading on the scale or balance.

Mass
(kg)

- | | | |
|----|-------------------|-------|
| 1. | 1 kilogram box. | _____ |
| 2. | Textbook. | _____ |
| 3. | Bag of sugar. | _____ |
| 4. | Package of paper. | _____ |
| 5. | Your own mass. | _____ |

B. DEVELOP YOUR ABILITY TO ESTIMATE IN KILOGRAMS

For the following items ESTIMATE the mass of the object in kilograms, then use the scale or balance to find the exact mass of the object. Write the exact mass in the MEASUREMENT column. Determine how close your estimate is:

	Estimate (kg)	Measurement (kg)	How Close Were You?
1.	_____	_____	_____
2.	_____	_____	_____
3.	_____	_____	_____
4.	_____	_____	_____
5.	_____	_____	_____



II. THE GRAM (g)

A. DEVELOP A FEELING FOR A GRAM

1. Take a colored plastic cube. Hold it in your hand. Shake the cube in your palm as if shaking dice. Feel the pressure on your hand when the cube is in motion, then when it is not in motion.

THAT IS HOW HEAVY A GRAM IS!

2. Take a second cube and attach it to the first. Shake the cubes in first one hand and then the other hand; rest the cubes near the tips of your fingers, moving your hand up and down.

THAT IS THE MASS OF TWO GRAMS!

3. Take five cubes in one hand and shake them around.

THAT IS THE MASS OF FIVE GRAMS!

B. DEVELOP YOUR ABILITY TO ESTIMATE IN GRAMS

You are now ready to improve your ability to estimate in grams. Remember how heavy the 1 gram cube is, how heavy the two gram cubes are, and how heavy the five gram cubes are. For each of the following items, follow the procedures used for estimating in kilograms.

	Estimate (g)	Measurement (g)	How Close Were You?
1. Two thumbtacks.	_____	_____	_____
2. Pencil.	_____	_____	_____
3. Two-page letter and envelope.	_____	_____	_____
4. Nickel.	_____	_____	_____
5. Apple.	_____	_____	_____
6. Package of margarine.	_____	_____	_____



TEMPERATURE MEASUREMENT ACTIVITIES

Degree Celsius

I. DEGREE CELSIUS (°C)

Degree Celsius (°C) is the metric measure for temperature.

A. DEVELOP A FEELING FOR DEGREE CELSIUS

Take a Celsius thermometer. Look at the marks on it.

1. Find 0 degrees.

WATER FREEZES AT ZERO DEGREES CELSIUS (0°C)

WATER BOILS AT 100 DEGREES CELSIUS (100°C)

2. Find the temperature of the room. _____ °C. Is the room cool, warm, or about right?
3. Put some hot water from the faucet into a container. Find the temperature. _____ °C. Dip your finger quickly in and out of the water. Is the water very hot, hot, or just warm?
4. Put some cold water in a container with a thermometer. Find the temperature. _____ °C. Dip your finger into the water. Is it cool, cold, or very cold?
5. Bend your arm with the inside of your elbow around the bottom of the thermometer. After about three minutes find the temperature. _____ °C. Your skin temperature is not as high as your body temperature.

NORMAL BODY TEMPERATURE IS 37 DEGREES CELSIUS (37°C).

A FEVER IS 39°C.

A VERY HIGH FEVER IS 40°C.

B. DEVELOP YOUR ABILITY TO ESTIMATE IN DEGREES CELSIUS

For each item, ESTIMATE and write down how many degrees Celsius you think it is. Then measure and write the MEASUREMENT. See how close your estimates and actual measurements are.

	Estimate (°C)	Measurement (°C)	How Close Were You?
1. Mix some hot and cold water in a container. Dip your finger into the water.	_____	_____	_____
2. Pour out some of the water. Add some hot water. Dip your finger <u>quickly</u> into the water.	_____	_____	_____
3. Outdoor temperature.	_____	_____	_____
4. Sunny window sill.	_____	_____	_____
5. Mix of ice and water.	_____	_____	_____
6. Temperature at floor.	_____	_____	_____
7. Temperature at ceiling.	_____	_____	_____

UNIT 2

OBJECTIVES

The student will recognize and use the metric terms, units, and symbols used in this occupation.

- Given a metric unit, state its use in this occupation.
- Given a measurement task in this occupation, select the appropriate metric unit and measurement tool.

SUGGESTED TEACHING SEQUENCE

1. Assemble metric measurement tools (rules, tapes, scales, thermometers, etc.) and objects related to this occupation.
2. Discuss with students how to read the tools.
3. Present and have students discuss Information Sheet 2 and Table 2.
4. Have students learn occupationally-related metric measurements by completing Exercises 6 and 7.
5. Test performance by using Section A of "Testing Metric Abilities."

METRICS IN THIS OCCUPATION

Changeover to the metric system is under way. Large corporations are already using metric measurement to compete in the world market. The metric system has been used in various parts of industrial and scientific communities for years. Legislation, passed in 1975, authorizes an orderly transition to use of the metric system. As businesses and industries make this metric changeover, employees will need to use metric measurement in job-related tasks.

Table 2 lists those metric terms which are most commonly used in this occupation. These terms are replacing the measurement units used currently. What kinds of job-related tasks use measurement? Think of the many different kinds of measurements you now make and use Table 2 to discuss the metric terms which replace them. See if you can add to the list of uses beside each metric term.

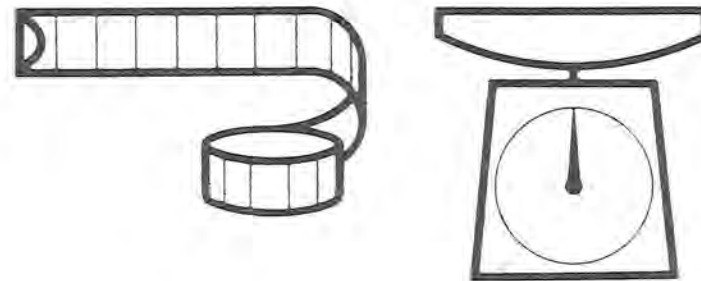

METRIC UNITS FOR PLUMBING AND PIPEFITTING

Quantity	Unit	Symbol	Use
Linear dimensions	millimetre	mm	size of pipe and fittings
	centimetre	cm	lengths of pipe, fixtures
	metre	m	
Surface and space dimensions	square centimetre	cm ²	safe pan area, pipe chase areas, wall sleeve space, fixtures
	square metre	m ²	roof drains, floor drains, interceptors
Mass	gram	g	chemicals
	kilogram	kg	fixtures, pipe, fittings, chemicals
	metric ton	t	boilers, solar panels
Excavation	cubic metre	m ³	trench construction, septic tank
Capacity	millilitre	ml	chemicals and solvents, pressure tanks, expansion tanks
	litre	l	water storage tanks, chemicals
Flow rates	millilitres per second	ml/s	pipe sizes for systems, circulating pumps, automatic gas valves
	litres per second	l/s	
Velocity of flow	millilitres per second	ml/s	frictional loss in pipe, fittings, equipment, softener backwash requirements
	litres per second	l/s	
Pressure	kilopascal	kPa	main and service pressure, hot water heating, water system design, calculating pump sizes (400 kPa about the "force" of water from a faucet)
	kilopascals per second	kPa/s	pressure drops in systems
Heat energy	kilojoule	kJ	amount of heat necessary to produce hot water and steam
Temperature	degree Celsius	°C	solar panels, hot water heating, hot water heaters, boilers, steam



TRYING OUT METRIC UNITS

To give you practice with metric units, first estimate the measurements of the items below. Write down your best guess next to the item. Then actually measure the item and write down your answers using the correct metric symbols. The more you practice, the easier it will be.

	Estimate	Actual
Length		
1. Palm width		
2. Hand span		
3. Ceiling height of this room		
4. Width of paper clip		
5. Thickness of nickel		
6. Width of this room		
7. Diameter of small pipe		
8. Length of full joint of pipe		
9. Length of pipe wrench		
Area		
10. Desk top		
11. Classroom floor		
12. Workbench		
13. Sheet of paper		
14. Parking lot		
Volume/Capacity		
15. Small bottle		
	Estimate	Actual
16. Measuring cup (metric)		
17. Milk container		
18. Bucket		
19. Small box		
20. Tool box		
21. Toilet tank		
22. Hot water tank		
Mass		
23. Textbook		
24. Yourself		
25. Cold chisel		
26. A litre of water (net)		
27. Roll of 50/50 solder		
28. Bar of caulking lead		
Temperature		
29. Melting point of tin		
30. Room		
31. Outside		
32. Hot tap water		
33. Cold tap water		



PLUMBING AND FITTING WITH METRICS

It is important to know what metric measurement to use. Show what measurement to use in the following situations.		15. Amount of water in a water closet tank	
1. Capacity of a boiler expansion tank		16. Flow rate for a drinking fountain or water cooler	
2. Proper spacing for horizontal pipe supports		17. Temperature of hot water	
3. Center-to-center distance of assembled pipe		18. Automatic gas valve flow rate	
4. End-to-center distance of assembled pipe		19. Amount of heat required for steam production	
5. End-to-back distance of assembled pipe		20. Area of floor drain	
6. Air-pressure test assembled pipe		21. Mass of a fixture	
7. Volume of water heater		22. Natural gas pressure	
8. Flow rate for a supply-return fitting		23. Flueliner size	
9. Amount of concrete for boiler setting pad		24. Coverage of fire sprinkler head	
10. Amount of insulation for sectional boiler			
11. Capacity of propane cylinder			
12. Volume of lead pot			
13. Rough-in height of wall hung lavatory			
14. Proper spacing for domestic hot and cold water lines			

METRIC PIPING DIMENSIONS

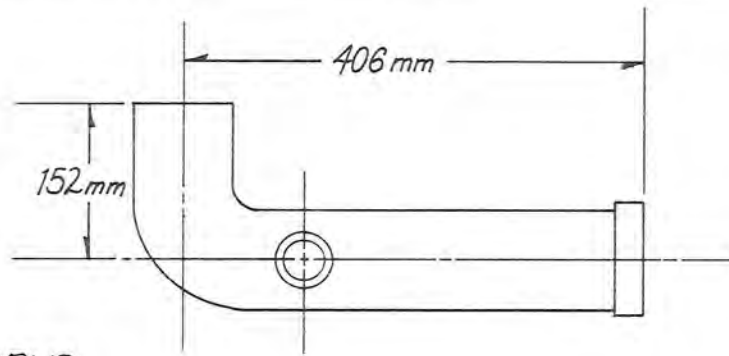

CLOSET BEND

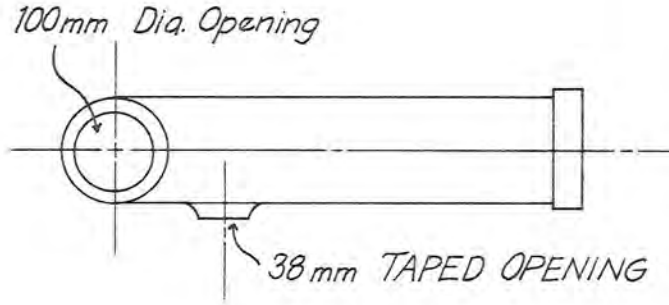

PIPE MEASUREMENT CENTER TO CENTER (C-C)

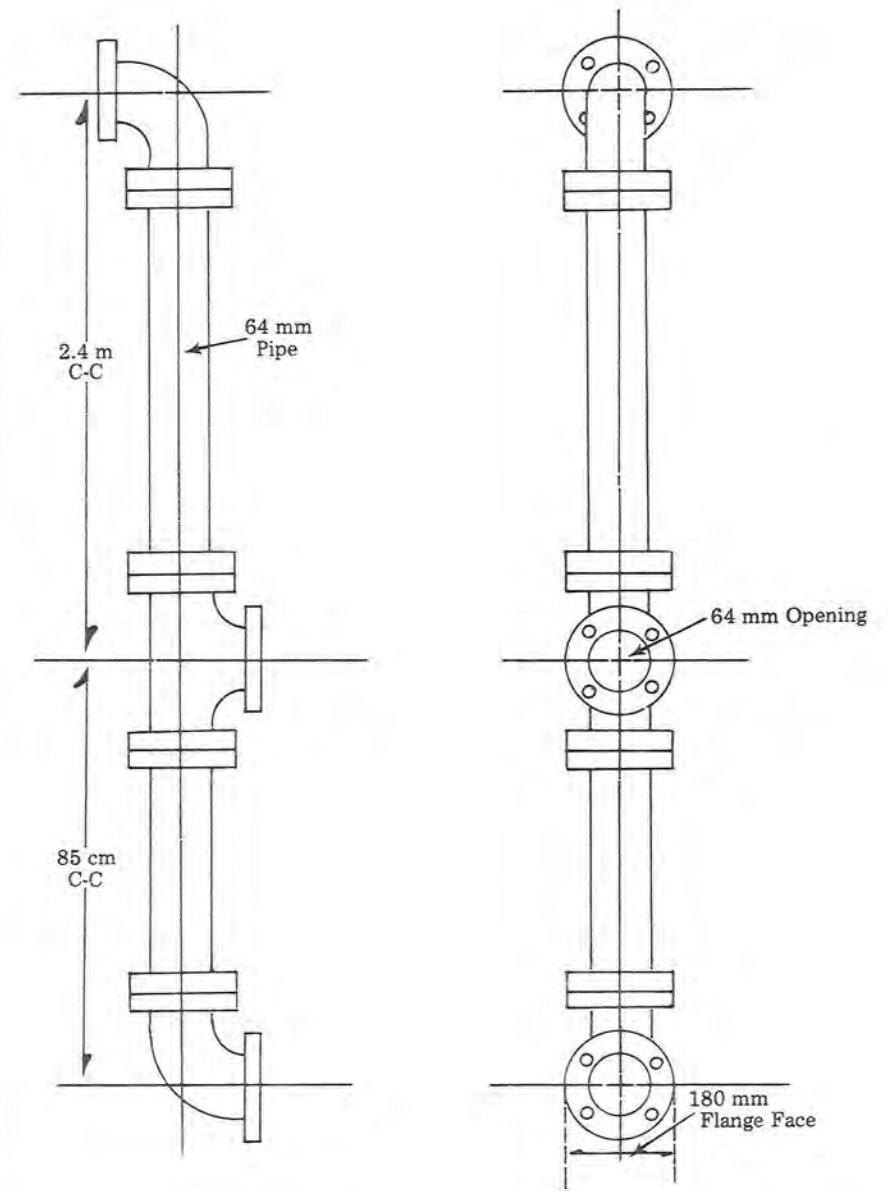
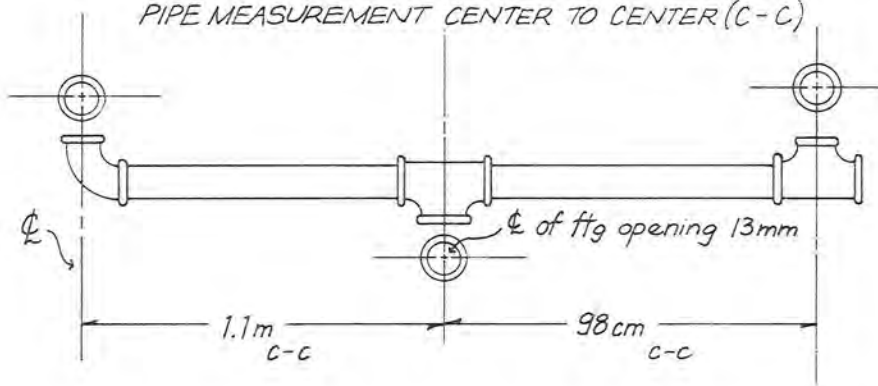

UNIT 3

OBJECTIVE

The student will recognize and use metric equivalents.

- Given a metric unit, state an equivalent in a larger or smaller metric unit.

SUGGESTED TEACHING SEQUENCE

- Make available the Information Sheets (3 - 8) and the associated Exercises (8 - 14), one at a time.
- As soon as you have presented the Information, have the students complete each Exercise.
- Check their answers on the page titled ANSWERS TO EXERCISES AND TEST.
- Test performance by using Section B of "Testing Metric Abilities."

METRIC-METRIC EQUIVALENTS

Centimetres and Millimetres

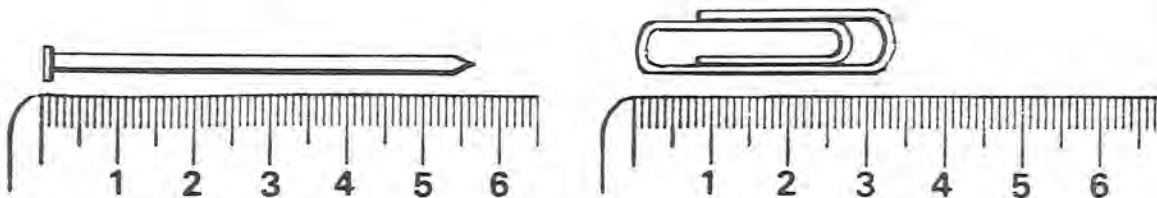

Look at the picture of the nail next to the ruler. The nail is 57 mm long. This is 5 cm + 7 mm. There are 10 mm in each cm, so 1 mm = 0.1 cm (one-tenth of a centimetre). This means that 7 mm = 0.7 cm, so 57 mm = 5 cm + 7 mm
 = 5 cm + 0.7 cm
 = 5.7 cm. Therefore 57 mm is the same as 5.7 cm.

Now measure the paper clip. It is 34 mm. This is the same as 3 cm + _____ mm. Since each millimetre is 0.1 cm (one-tenth of a centimetre), 4 mm = _____ cm. So, the paper clip is 34 mm = 3 cm + 4 mm
 = 3 cm + 0.4 cm
 = 3.4 cm. This means that 34 mm is the same as 3.4 cm.

Information Sheet 3

Now you try some.

- | | |
|-----------------------|-------------------------|
| a) 26 mm = _____ cm | e) 132 mm = _____ cm |
| b) 583 mm = _____ cm | f) 802 mm = _____ cm |
| c) 94 mm = _____ cm | g) 1 400 mm = _____ cm |
| d) 680 mm = _____ cm | h) 2 307 mm = _____ cm |

Exercise 8

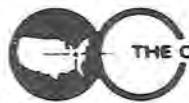

Metres, Centimetres, and Millimetres

There are 100 centimetres in one metre. Thus,

$$\begin{aligned} 2 \text{ m} &= 2 \times 100 \text{ cm} = 200 \text{ cm}, \\ 3 \text{ m} &= 3 \times 100 \text{ cm} = 300 \text{ cm}, \\ 8 \text{ m} &= 8 \times 100 \text{ cm} = 800 \text{ cm}, \\ 36 \text{ m} &= 36 \times 100 \text{ cm} = 3\,600 \text{ cm}. \end{aligned}$$

There are 1 000 millimetres in one metre, so

$$\begin{aligned} 2 \text{ m} &= 2 \times 1\,000 \text{ mm} = 2\,000 \text{ mm}, \\ 3 \text{ m} &= 3 \times 1\,000 \text{ mm} = 3\,000 \text{ mm}, \\ 6 \text{ m} &= 6 \times 1\,000 \text{ mm} = 6\,000 \text{ mm}, \\ 24 \text{ m} &= 24 \times 1\,000 \text{ mm} = 24\,000 \text{ mm}. \end{aligned}$$

From your work with decimals you should know that

one-half of a metre can be written 0.5 m (five-tenths of a metre),
one-fourth of a centimetre can be written 0.25 cm
(twenty-five hundredths of a centimetre).

This means that if you want to change three-fourths of a metre to millimetres, you would multiply by 1 000. So

$$\begin{aligned} 0.75 \text{ m} &= 0.75 \times 1\,000 \text{ mm} \\ &= \frac{75}{100} \times 1\,000 \text{ mm} \\ &= 75 \times \frac{1\,000}{100} \text{ mm} \\ &= 75 \times 10 \text{ mm} \\ &= 750 \text{ mm}. \text{ This means that } 0.75 \text{ m} = 750 \text{ mm}. \end{aligned}$$

Information Sheet 4

Fill in the following chart.

metre m	centimetre cm	millimetre mm
1	100	1 000
2	200	
3		
9		
		5 000
74		
0.8	80	
0.6		600
	2.5	25
		148
	639	

Exercise 9

Millilitres to Litres

There are 1 000 millilitres in one litre. This means that

$$\begin{aligned} 2\,000 \text{ millilitres} &\text{ is the same as } 2 \text{ litres}, \\ 3\,000 \text{ ml} &\text{ is the same as } 3 \text{ litres}, \\ 4\,000 \text{ ml} &\text{ is the same as } 4 \text{ litres}, \\ 12\,000 \text{ ml} &\text{ is the same as } 12 \text{ litres}. \end{aligned}$$

Since there are 1 000 millilitres in each litre, one way to change millilitres to litres is to divide by 1 000. For example,

$$\begin{aligned} \text{Or } 1\,000 \text{ ml} &= \frac{1\,000}{1\,000} \text{ litre} = 1 \text{ litre}. \\ 2\,000 \text{ ml} &= \frac{2\,000}{1\,000} \text{ litres} = 2 \text{ litres}. \end{aligned}$$

And, as a final example,

$$28\,000 \text{ ml} = \frac{28\,000}{1\,000} \text{ litres} = 28 \text{ litres}.$$

What if something holds 500 ml? How many litres is this? This is worked the same way.

$$500 \text{ ml} = \frac{500}{1\,000} \text{ litre} = 0.5 \text{ litre (five-tenths of a litre)}. \text{ So } 500 \text{ ml} \text{ is the same as one-half (0.5) of a litre.}$$

Change 57 millilitres to litres.

$$57 \text{ ml} = \frac{57}{1\,000} \text{ litre} = 0.057 \text{ litre (fifty-seven thousandths of a litre).}$$

Information Sheet 5

Now you try some. Complete the following chart.

millilitres (ml)	litres (l)
3 000	3
6 000	
	8
14 000	
	23
300	0.3
700	
	0.9
250	
	0.47
275	

Exercise 10



Litres to Millilitres

What do you do if you need to change litres to millilitres? Remember, there are 1 000 millilitres in one litre, or 1 litre = 1 000 ml.

So,

$$\begin{aligned} 2 \text{ litres} &= 2 \times 1\,000 \text{ ml} = 2\,000 \text{ ml}, \\ 7 \text{ litres} &= 7 \times 1\,000 \text{ ml} = 7\,000 \text{ ml}, \\ 13 \text{ litres} &= 13 \times 1\,000 \text{ ml} = 13\,000 \text{ ml}, \\ 0.65 \text{ litre} &= 0.65 \times 1\,000 \text{ ml} = 650 \text{ ml}. \end{aligned}$$

Information Sheet 6

Now you try some. Complete the following chart.

litres l	millilitres ml
8	8 000
5	
46	
	32 000
0.4	
0.53	
	480

Exercise 11

Grams to Kilograms

There are 1 000 grams in one kilogram. This means that

2 000 grams is the same as 2 kilograms,

5 000 g is the same as 5 kg,

700 g is the same as 0.7 kg, and so on.

To change from grams to kilograms, you use the same procedure for changing from millilitres to litres.

Information Sheet 7

Try the following ones.

grams g	kilograms kg
4 000	4
9 000	
23 000	
	8
300	
275	

Exercise 12

Kilograms to Grams

To change kilograms to grams, you multiply by 1 000.

$$\begin{aligned} 4 \text{ kg} &= 4 \times 1\,000 \text{ g} = 4\,000 \text{ g}, \\ 23 \text{ kg} &= 23 \times 1\,000 \text{ g} = 23\,000 \text{ g}, \\ 0.75 \text{ kg} &= 0.75 \times 1\,000 \text{ g} = 750 \text{ g}. \end{aligned}$$

Information Sheet 8

Complete the following chart.

kilograms kg	grams g
7	7 000
11	
	25 000
0.4	
0.63	
	175

Exercise 13

Changing Units at Work

Some of the things you use in this occupation may be measured in different metric units. Practice changing each of the following to metric equivalents by completing these statements.

- 500 cm of rope is _____ m
- 250 ml of solution is _____ l
- 5 cm diameter pipe is _____ mm
- 2 500 g of lead is _____ kg
- 120 mm pipe is _____ cm
- 0.25 litre of cutting oil is _____ ml
- 2 000 kg of sand is _____ t
- 0.5 litre of concentrate is _____ ml
- 2 m board is _____ mm
- 500 g of solder is _____ kg
- 500 ml pipe compound is _____ l
- 0.5 t of cement is _____ kg
- 10 m of wire is _____ cm
- 2.5 cm diameter pipe is _____ mm
- 2 400 mm wall panel length is _____ cm
- 2 500 g of asbestos is _____ kg

Exercise 14



UNIT 4

OBJECTIVE

The student will recognize and use instruments, tools, and devices for measurement tasks in this occupation.

- Given metric and Customary tools, instruments, or devices, differentiate between metric and Customary.
- Given a measurement task, select and use an appropriate tool, instrument or device.
- Given a metric measurement task, judge the metric quantity within 20% and measure within 2% accuracy.

SUGGESTED TEACHING SEQUENCE

1. Assemble metric and Customary measuring tools and devices (rules, scales, $^{\circ}\text{C}$ thermometer, drill bits, wrenches, micrometer, vernier calipers, feeler gages) and display in separate groups at learning stations.
2. Have students examine metric tools and instruments for distinguishing characteristics and compare them with Customary tools and instruments.
3. Have students verbally describe characteristics.
4. Present or make available Information Sheet 9.
5. Mix metric and Customary tools or equipment at learning station. Give students Exercises 15 and 16.
6. Test performance by using Section C of "Testing Metric Abilities."

SELECTING AND USING METRIC INSTRUMENTS , TOOLS AND DEVICES

Selecting an improper tool or misreading a scale can result in an improper sales form, damaged materials, or injury to self or fellow workers. For example, putting 207 pounds per square inch of pressure (psi) in a boiler designed for 207 kilopascals (about 30 psi) could cause a fatal accident. Here are some suggestions:

1. Find out in advance whether Customary or metric units, tools, instruments, or products are needed for a given task.
2. Examine the tool or instrument before using it.
3. The metric system is a decimal system. Look for units marked off in whole numbers, tens or tenths, hundreds or hundredths.
4. Look for metric symbols on the tools or gages such as m, mm, kg, g, kPa, etc.
5. Look for decimal fractions (0.25) or decimal mixed fractions (2.50) rather than common fractions ($\frac{3}{8}$) on drill bits, feeler gages, etc.
6. Some products may have a special metric symbol such as a block M to show they are metric.
7. Don't force bolts, wrenches, or other devices which are not fitting properly.
8. Practice selecting and using tools, instruments, and devices.

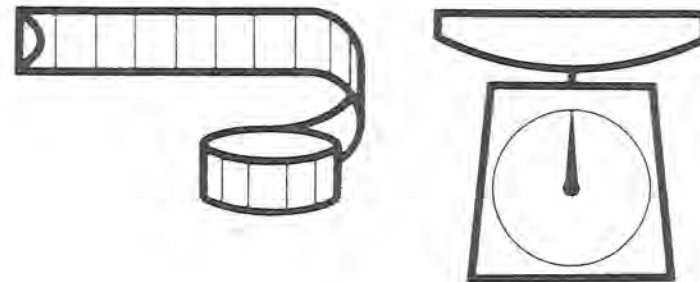

WHICH TOOLS FOR THE JOB?

Practice and prepare to demonstrate your ability to *identify, select, and use* metric-scaled tools and instruments for the tasks given below. You should be able to use the measurement tools to the appropriate precision of the tool, instrument, or task.

Select and demonstrate or describe use of tools, instruments, or devices to:

1. Order pre-mixed concrete for a sidewalk as long as your classroom and 1 m wide and 10 cm thick.
2. From a piece of steel pipe 2 m in length, cut, thread, and assemble a piece of pipe and two 90° elbows to a fitted length of 1.2 m.
3. Unbolt an assembled pair of standard companion flanges.
4. Cut a new gasket for an assembled pair of standard companion flanges and re-assemble.
5. Describe the difference between a Customary and a metric pipe wrench.
6. Measure the normal water pressure of your building.
7. Measure the Normal Water Pressure of your building.
8. Unbolt an assembled pair of standard companion flanges.
9. Hang a lavatory the correct height.
10. Measure correct amount of solder to use in soldering a 2.54 cm joint.

MEASURING UP IN PIPE FITTING

For the tasks below, estimate the metric measurement to within 20% of actual measurement, and verify the estimation by measuring to within 2% of actual measurement.

	Estimate	Verify
1. Work space or bench large enough for pipe assembly.		
2. Volume of a tool box.		
3. Volume of a gang box.		
4. Amount of cast iron soil pipe necessary to extend 1 m beyond both sides of classroom.		
5. Pipe covering for assembled pipe		
6. Construct two parallel lines of pipe and connect together with 45° offset.		
7. Insulation for fittings on assembled pipe		
8. Amount of radiation necessary for this room		
9. Find the largest available entry into classroom		
10. Volume of a 680 kg pressure tank		



UNIT 5

OBJECTIVE

The student will recognize and use metric and Customary units interchangeably in ordering, selling, and using products and supplies in this occupation.

- Given a Customary (or metric) measurement, find the metric (or Customary) equivalent on a conversion table.
- Given a Customary unit, state the replacement unit.

SUGGESTED TEACHING SEQUENCE

- Assemble packages and containers of materials.
- Present or make available Information Sheet 10 and Table 3.
- Have students find approximate metric-Customary equivalents by using Exercise 17.
- Test performance by using Section D of "Testing Metric Abilities."

METRIC-CUSTOMARY EQUIVALENTS

During the transition period there will be a need for finding equivalents between systems. Conversion tables list calculated equivalents between the two systems. When a close equivalent is needed, a conversion table can be used to find it. Follow these steps:

- Determine which conversion table is needed.
- Look up the known number in the appropriate column; if not listed, find numbers you can add together to make the total of the known number.
- Read the equivalent(s) from the next column.

Table 3 on the next page gives an example of a metric-Customary conversion table which you can use for practice in finding approximate equivalents. Table 3 can be used with Exercise 17, Part 2 and Part 3.

Below is a table of metric-Customary equivalents which tells you what the metric replacements for Customary units are.* This table can be used with Exercise 17, Part 1 and Part 3. The symbol \approx means "nearly equal to."

1 cm \approx 0.39 inch	1 inch \approx 2.54 cm	1 ml \approx 0.2 tsp	1 tsp \approx 5 ml
1 m \approx 3.28 feet	1 foot \approx 0.305 m	1 ml \approx 0.07 tbsp	1 tbsp \approx 15 ml
1 m \approx 1.09 yards	1 yard \approx 0.91 m	1 l \approx 33.8 fl oz	1 fl oz \approx 29.6 ml
1 km \approx 0.62 mile	1 mile \approx 1.61 km	1 l \approx 4.2 cups	1 cup \approx 237 ml
1 cm ² \approx 0.16 sq in	1 sq in \approx 6.5 cm ²	1 l \approx 2.1 pts	1 pt \approx 0.47 l
1 m ² \approx 10.8 sq ft	1 sq ft \approx 0.09 m ²	1 l \approx 1.06 qt	1 qt \approx 0.95 l
1 m ² \approx 1.2 sq yd	1 sq yd \approx 0.8 m ²	1 l \approx 0.26 gal	1 gal \approx 3.79 l
1 hectare \approx 2.5 acres	1 acre \approx 0.4 hectare	1 gram \approx 0.035 oz	1 oz \approx 28.3 g
1 cm ³ \approx 0.06 cu in	1 cu in \approx 16.4 cm ³	1 kg \approx 2.2 lb	1 lb \approx 0.45 kg
1 m ³ \approx 35.3 cu ft	1 cu ft \approx 0.03 m ³	1 metric ton \approx 2205 lb	1 ton \approx 907.2 kg
1 m ³ \approx 1.3 cu yd	1 cu yd \approx 0.8 m ³	1 kPa \approx 0.145 psi	1 psi \approx 6.895 kPa

*Adapted from *Let's Measure Metric. A Teacher's Introduction to Metric Measurement*. Division of Educational Redesign and Renewal, Ohio Department of Education, 65 S. Front Street, Columbus, OH 43215. 1975.



CONVERSION TABLES

MILLIMETRES TO CENTIMETRES TO INCHES									INCHES TO CENTIMETRES TO MILLIMETRES					
mm	cm	in.	mm	cm	in.	mm	cm	in.	in.	cm	mm	in.	cm	mm
100	10	3.93	10	1	0.39	1	0.1	0.04	1	2.54	25.4	1/8	0.32	3.2
200	20	7.87	20	2	0.79	2	0.2	0.08	2	5.08	50.8	1/4	0.64	6.4
300	30	11.81	30	3	1.18	3	0.3	0.12	3	7.62	76.2	1/2	1.27	12.7
400	40	15.74	40	4	1.57	4	0.4	0.16	4	10.16	101.6	3/4	1.91	19.1
500	50	19.68	50	5	1.97	5	0.5	0.20	5	12.70	127.0			
600	60	23.62	60	6	2.36	6	0.6	0.24	6	15.24	152.4			
700	70	27.56	70	7	2.76	7	0.7	0.28	7	17.78	177.8			
800	80	31.50	80	8	3.15	8	0.8	0.31	8	20.32	203.2			
900	90	35.43	90	9	3.54	9	0.9	0.35	9	22.86	228.6			
									10	25.40	254.0			
1000 mm or 1 metre = 39.37 inches									12 in. or 1 ft. = 30.48 cm or 304.8 mm					

METRES TO FEET						FEET TO METRES					
m	ft.	m	ft.	m	ft.	ft.	m	ft.	m	ft.	m
100	328.08	10	32.81	1	3.28	100	30.48	10	3.05	1	0.30
200	656.17	20	65.62	2	6.56	200	60.96	20	6.10	2	0.61
300	984.25	30	98.43	3	9.84	300	91.44	30	9.14	3	0.91
400	1312.34	40	131.23	4	13.12	400	121.92	40	12.19	4	1.22
500	1640.42	50	164.04	5	16.40	500	152.40	50	15.24	5	1.52
600	1968.50	60	196.85	6	19.69	600	182.88	60	18.29	6	1.83
700	2296.59	70	229.66	7	22.97	700	213.36	70	21.34	7	2.13
800	2624.67	80	262.47	8	26.25	800	243.84	80	24.38	8	2.44
900	2952.76	90	295.28	9	29.53	900	274.32	90	27.43	9	2.74
1000	3280.84					1000	304.80				



ANY WAY YOU WANT IT

1. You are working in a shop or on a job site. With the change to metric measurement some of the things you order, sell or use are marked only in metric units. You will need to be familiar with appropriate Customary equivalents in order to communicate with customers and suppliers who use Customary units. To develop your skill use the Table on Information Sheet 10 and give the approximate metric quantity (both number and unit) for each of the following Customary quantities.

Customary Quantity	Metric Quantity
a) 2 lb. caulking lead	
b) 4 qts. cutting oil	
c) 3/4 in. diameter pipe	
d) 10 sq. ft. of floor area	
e) 100 lb. cement	
f) 18 in. pipe	
g) 2 gallon can	
h) 1 pt. of penetrating oil	
i) 6 fl. oz. of spray paint	
j) 1 qt. lubricating oil	
k) 3 miles	
l) 30 psi pressure gage	
m) 25 lb. of lead	

2. Use the conversion tables from Table 3 to convert the following:

a) 12 ft. =	m	f) 90 ft. =	m
b) 3 1/4 in. =	mm	g) 16 in. =	cm
c) 50 ft. =	m	h) 100 m =	ft.
d) 2 m =	ft.	i) 30.9 cm =	in.
e) 180 mm =	in.	j) 620 m =	ft.

3. Complete the Requisition Form using the items listed. Convert the Customary quantities to metric before filling out the form. Complete all the information (Date, For, Job No., etc.).

Requisition one of each of the following:

- a) 5 lb. can of caulking lead
- b) gallon of cutting oil
- c) 12 ft. of 3/4 in. copper tubing
- d) 1 lb. roll of 50/50 solder
- e) 60 lb. bag of pre-mixed concrete
- f) roll of 2 in. boiler tape

REQUISITION		
		Date _____
For _____		
Job No. _____		Date Wanted _____
Deliver to _____		
QTY	UNIT	ITEM
Requested by _____		
Approved by _____		



SECTION A

1. One kilogram is about the mass of a:
 - [A] nickel
 - [B] apple seed
 - [C] basketball
 - [D] Volkswagen "Beetle"
2. A square metre is about the area of:
 - [A] this sheet of paper
 - [B] a card table top
 - [C] a bedspread
 - [D] a postage stamp
3. The length of pipe would be measured in:
 - [A] cubic centimetres
 - [B] litres
 - [C] grams per square metre
 - [D] centimetres
4. The diameter of pipe would be measured in:
 - [A] millimetres
 - [B] millilitres
 - [C] kilograms
 - [D] kilometres
5. A standard length of steel pipe is measured in:
 - [A] cubic centimetres
 - [B] metres
 - [C] litres
 - [D] millimetres

6. The correct way to write twenty grams is:
 - [A] 20 gms
 - [B] 20 Gm.
 - [C] 20 g.
 - [D] 20 g
7. The correct way to write twelve thousand millimetres is:
 - [A] 12,000 mm.
 - [B] 12.000 mm
 - [C] 12 000mm
 - [D] 12 000 mm

SECTION B

8. A pipe 100 millimetres in diameter also has a diameter of:
 - [A] 0.1 centimetre
 - [B] 100 centimetres
 - [C] 1 000 centimetres
 - [D] 10 centimetres
9. A steel boiler having a mass of approximately 1 000 kilograms would also have a mass of:
 - [A] 1 metric ton
 - [B] 100 milligrams
 - [C] 10 grams
 - [D] 1 000 litres
10. A pipe 20 centimetres long also has a length of:
 - [A] 2 millimetres
 - [B] 0.2 millimetre
 - [C] 200 millimetres
 - [D] 2 000 millimetres



SECTION C

11. For measuring centimetres and millimetres you would use a:

[A] scale
 [B] ruler
 [C] pressure gage
 [D] container

12. For measuring kilopascals you would use a:

[A] pressure gage
 [B] scale
 [C] ruler
 [D] container

13. Estimate the length of the line segment below:



[A] 23 grams
 [B] 6 centimetres
 [C] 40 millimetres
 [D] 14 pascals

14. Estimate the length of the line segment below:



[A] 10 millimetres
 [B] 4 centimetres
 [C] 4 pascals
 [D] 23 milligrams

SECTION D

15. The metric unit for liquid measure which replaces the fluid ounce is:

[A] litre
 [B] cubic metre
 [C] gram
 [D] millilitre

16. The metric unit for pressure which replaces pounds per square inch (psi) is:

[A] gram
 [B] kilopascal
 [C] cubic centimetre
 [D] millilitre

Use this conversion table to answer questions 17 and 18.

m^2	$ft.^2$	$ft.^2$	m^2
1	10.76	1	0.09
2	21.53	2	0.18
3	32.29	3	0.28
4	43.06	4	0.37
5	53.81	5	0.46
6	64.58	6	0.56
7	75.35	7	0.65
8	86.11	8	0.74
9	96.87	9	0.84
10	107.64	10	0.93

17. The equivalent of $14 ft.^2$ is:

[A] $37.16 m^2$
 [B] $0.93 m^2$
 [C] $2.6 m^2$
 [D] $1.3 m^2$

18. The equivalent of $15 m^2$ is:

[A] $161.45 ft.^2$
 [B] $973.06 ft.^2$
 [C] $8.73 ft.^2$
 [D] $97.33 ft.^2$

TESTING METRIC ABILITIES



ANSWERS TO EXERCISES AND TEST

EXERCISES 1 THRU 6

The answers depend on the items used for the activities.

EXERCISE 7

Currently accepted metric units of measurement for each question are shown in Table 2. Standards in each occupation are being established now, so answers may vary.

EXERCISE 8

- | | |
|------------|-------------|
| a) 2.6 cm | e) 13.2 cm |
| b) 58.3 cm | f) 80.2 cm |
| c) 9.4 cm | g) 140.0 cm |
| d) 68.0 cm | h) 230.7 cm |

EXERCISES 9 THRU 13

Tables are reproduced in total. Answers are in parentheses.

Exercise 9

metre m	centimetre cm	millimetre mm
1	100	1 000
2	200	(2 000)
3	(300)	(3 000)
9	(900)	(9 000)
(5)	(500)	5 000
74	(7 400)	(74 000)
0.8	80	(800)
0.6	(60)	600
(0.025)	2.5	25
(0.148)	(14.8)	148
(6.39)	639	(6 390)

Exercise 10

millilitres ml	litres l
3 000	3
6 000	(6)
(8 000)	8
(14 000)	(14)
(23 000)	23
300	0.3
700	(0.7)
(900)	0.9
250	(0.25)
(470)	0.47
275	(0.275)

Exercise 11

litres l	millilitres ml
8	8 000
5	(5 000)
46	(46 000)
(32)	32 000
0.4	(400)
0.53	(530)
(0.48)	480

Exercise 12

grams g	kilograms kg
4 000	4
9 000	(9)
23 000	(23)
(8 000)	8
300	(0.3)
275	(0.275)

Exercise 13

kilograms kg	grams g
7	7 000
11	(11 000)
(25)	25 000
0.4	(400)
0.63	(630)
(0.175)	175

Exercise 14

- | | |
|------------|--------------|
| a) 5 m | i) 2 000 mm |
| b) 0.25 ml | j) 0.5 kg |
| c) 50 mm | k) 0.5 litre |
| d) 2.5 kg | l) 500 kg |
| e) 12 cm | m) 1 000 cm |
| f) 250 ml | n) 25 mm |
| g) 2 t | o) 240 cm |
| h) 500 ml | p) 2.5 kg |

EXERCISES 15 AND 16

The answers depend on the items used for the activities.

EXERCISE 17

Part 1.

- | | |
|-----------------------|---------------|
| a) 0.90 kg | h) 0.47 litre |
| b) 3.8 litres | i) 177.6 ml |
| c) 1.905 cm | j) 0.95 litre |
| d) 0.9 m ² | k) 4.83 km |
| e) 45 kg | l) 206.85 kPa |
| f) 45.72 cm | m) 11.25 kg |
| g) 7.58 litres | |

Part 2.

- 3.66 m
- 82.6 mm
- 15.24 m
- 6.56 ft.
- 7.08 in.
- 27.43 m
- 40.64 cm
- 328.08 ft.
- 12.16 in.
- 2,034.12 ft.

Part 3.

- 2.25 kg
- 3.79 litres
- 3.66m, 1.905 cm
- 0.45 kg
- 27 kg
- 5.08 cm

TESTING METRIC ABILITIES

- | | |
|------|-------|
| 1. C | 10. C |
| 2. B | 11. B |
| 3. D | 12. A |
| 4. A | 13. B |
| 5. B | 14. A |
| 6. D | 15. D |
| 7. D | 16. B |
| 8. D | 17. D |
| 9. A | 18. A |



**SUGGESTED METRIC TOOLS AND DEVICES
NEEDED TO COMPLETE MEASUREMENT TASKS
IN EXERCISES 1 THROUGH 5**

(* Optional)

LINEAR

Metre Sticks
Rules, 30 cm
Measuring Tapes, 150 cm
*Height Measure
*Metre Tape, 10 m
*Trundle Wheel
*Area Measuring Grid

MASS

Bathroom Scale
*Kilogram Scale
*Platform Spring Scale
5 kg Capacity
10 kg Capacity
Balance Scale with 8-piece
mass set
*Spring Scale, 6 kg Capacity

VOLUME/CAPACITY

*Nesting Measures, set of 5,
50 ml - 1 000 ml
Economy Beaker, set of 6,
50 ml - 1 000 ml
Metric Spoon, set of 5,
1 ml - 25 ml
Dry Measure, set of 3,
50, 125, 250 ml
Plastic Litre Box
Centimetre Cubes

TEMPERATURE

Celsius Thermometer

**SUGGESTED METRIC TOOLS AND DEVICES
NEEDED TO COMPLETE OCCUPATIONAL
MEASUREMENT TASKS**

In this occupation the tools needed to complete Exercises 6, 15, and 16 are indicated by “*.”

- * A. Assorted Metric Hardware—Hex nuts, washers, screws, cotter pins, etc.
- B. Drill Bits—Individual bits or sets, 1 mm to 13 mm range
- C. Vernier Caliper—Pocket slide type, 120 mm range
- D. Micrometer—Outside micrometer caliper, 0 mm to 25 mm range
- E. Feeler Gage—13 blades, 0.05 mm to 1 mm range
- * F. Metre Tape—50 or 100 m tape
- G. Thermometers—Special purpose types such as a clinical thermometer
- H. ¹ Temperature Devices—Indicators used for ovens, freezing/cooling systems, etc.
- * I. Tools—Metric open end or box wrench sets, socket sets, hex key sets
- J. Weather Devices—Rain gage, barometer, humidity, wind velocity indicators
- * K. ¹ Pressure Gages—Tire pressure, air, oxygen, hydraulic, fuel, etc.
- L. ¹ Velocity—Direct reading or vane type meter
- M. Road Map—State and city road maps
- N. Containers—Buckets, plastic containers, etc., for mixing and storing liquids
- O. Containers—Boxes, buckets, cans, etc., for mixing and storing dry ingredients

Most of the above items may be obtained from local industrial, hardware, and school suppliers. Also, check with your school district's math and science departments and/or local industries for loan of their metric measurement devices.

¹ Measuring devices currently are not available. Substitute devices (i.e., thermometer) may be used to complete the measurement task.



THE CENTER FOR VOCATIONAL EDUCATION

The Ohio State University • 1960 Kenny Road • Columbus Ohio 43210

REFERENCES

Implementing Metric Measurement Units in Career Education Programs.

Pokorney, Joseph L. Engineering Technology, Inc., 503 East Main Street, Mahomet, IL 61853, 1975, kit; ruler (20 cm); measuring tape (150 cm); Celsius thermometer; \$6.50; paper.

Instructional package with exercise sheets, transparency masters, and metric measuring devices. Approximately half of exercises are activity-based. "Think metric" strategy. Section on metric educational aids and sources. Includes worksheets and brief sections on farm operations, secretarial and clerical, transportation, nursing and health, drafting, shop practices, building trades, and home economics.

Let's Measure Metric. A Teacher's Introduction to Metric Measurement. Division of Educational Redesign and Renewal, Ohio Department of Education, 65 S. Front Street, Columbus, OH 43215, 1975, 80 pages; \$1.50, must include check to state treasurer.

Activity-oriented introduction to the metric system designed for independent or group inservice education study. Introductory information about metric measurement; reproducible exercises apply metric concepts to common measurement situations; laboratory activities for individuals or groups. Templates for making metre tape, litre box, square centimetre grid.

Measuring with Meters, or, How to Weigh a Gold Brick with a Meter-Stick. Metrication Institute of America, P.O. Box 236, Northfield, IL 60093, 1974, 23 min., 16 mm, sound, color; \$310.00 purchase, \$31.00 rental.

Film presents units for length, area, volume and mass, relating each unit to many common objects. Screen overprints show correct use of metric symbols and ease of metric calculations. Relationships among metric measures of length, area, volume, and mass are illustrated in interesting and unforgettable ways.

Metric Education, An Annotated Bibliography for Vocational, Technical and Adult Education. Product Utilization, The Center for Vocational Education, The Ohio State University, Columbus, OH 43210, 1974, 149 pages; \$10.00.

Comprehensive bibliography of instructional materials, reference materials and resource list for secondary, post-secondary, teacher education, and adult basic education. Instructional materials indexed by 15 occupational clusters, types of materials, and educational level.

Metric Education, A Position Paper for Vocational, Technical and Adult Education. Product Utilization, The Center for Vocational Education, The Ohio State University, Columbus, OH 43210, 1975, 46 pages; \$3.00.

Paper for teachers, curriculum developers, and administrators in vocational, technical and adult education. Covers issues in metric education, the metric system, the impact of metrication on vocational and technical education, implications of metric instruction for adult basic education, and curriculum and instructional strategies.

Metrics in Career Education. Lindbeck, John R., Charles A. Bennett Company, Inc., 809 W. Detweiller Drive, Peoria, IL 61614, 1975, 103 pages, \$3.60, paper; \$2.70 quantity school purchase.

Presents metric units and notation in a well-illustrated manner. Individual chapters on metrics in drafting, metalworking, woodworking, power and energy, graphic arts, and home economics. Chapters followed by several learning activities for student use. Appendix includes conversion tables and charts.

Metric Practice Guide ASTM E 380-72e. American Society for Testing and Materials, 1916 Race Street, Philadelphia, PA 19103, 1972, 34 p., \$1.50, paper.

Detailed presentation on SI units and symbols, style and usage, rules for conversion and rounding. Appendices on terminology, development of SI units, and conversion factors. Includes current base and derived SI units, and approved deviation from SI.

METRIC SUPPLIERS

Brown & Sharpe Manufacturing Co., Precision Park, North Kingstown, RI 02852

Industrial quality micrometers, steel rules, screw pitch and thickness gages, squares, depth gages, calipers, dial indicators, conversion charts and guides.

Dick Blick Company, P.O. Box 1267, Galesburg, IL 61401

Instructional quality rules, tapes, metre sticks, cubes, height measures, trundle wheels, measuring cups and spoons, personal scales, gram/kilogram scales, feeler and depth gages, beakers, thermometers, kits and other aids.

Millimeter Industrial Supply Corp., 162 Central Avenue, Farmingdale, L. I., NY 11735

Industrial fasteners, taps, dies, reamers, drills, wrenches, rings, bushings, calipers, steel rules and tapes, feeler gages.

Stanley Tools, 600 Myrtle Street, New Britain, CT 06050

Metric tapes and rules.

INFORMATION SOURCES

American National Metric Council, 1625 Massachusetts Avenue, N.W., Washington, D C 20036

Charts, posters, reports and pamphlets, *Metric Reporter* newsletter. National metric coordinating council representing industry, government, education, professional and trade organizations.

National Bureau of Standards, Office of Information Activities, U.S. Department of Commerce, Washington, D C 20234.

Free and inexpensive metric charts and publications, also lends films and displays.