

Federal Building and Fire Safety Investigation
of the World Trade Center Disaster

Fire Resistance Testing of WTC Floor System
Part 2

August 25, 2004

John L. Gross, Ph.D., P.E.
Research Structural Engineer

Building and Fire Research Laboratory
National Institute of Standards and Technology
U.S. Department of Commerce

- ❑ History of ASTM E119 testing
- ❑ Criteria used to determine fire resistance ratings
- ❑ Design and fabrication of test specimens
- ❑ Set-up of the UL fire tests
- ❑ Preliminary observations from completed tests
- ❑ Observing today's test

History of ASTM E119 testing

(Extremely) Brief History of Fire Endurance Testing

Harry Shoub, in a paper titled, “Early History of Fire Endurance Testing in the United States”¹ notes

- ❑ “...early knowledge of the requirements for fire protection resulted from a study of the behavior of structures in fire and from examination of fire damaged buildings,” and
- ❑ “...the development of skeleton-type construction made the necessity for fire endurance testing apparent.”
- ❑ “It can be noted here that of all the structural elements that comprise a building, floors have received the earliest, and for a considerable time, the most attention.”

¹ Presented to ASTM Committee E-5, February 1, 1961

(Extremely) Brief History of Fire Endurance Testing

Fire Endurance Testing of Floors

- ❑ The first tests of floors in the United States appear to have been conducted in Denver in 1890 for the Denver Equitable Building Company.
- ❑ In 1899, the New York City Building Code incorporated a fire test for constructions offered as equally “fireproof” as those listed in an earlier statute prescribing the materials to be used in the floor arches of buildings over a certain height.
- ❑ This fire test was apparently the first specified by law.

(Extremely) Brief History of Fire Endurance Testing

The Beginnings of ASTM E 119

- ❑ Committee P was organized by ASTM in 1905 largely as a result of the Baltimore fire of the year before. (Shoub)
- ❑ By 1906, ASTM Committee P (which would later become C-5 and eventually E-5) proposed a standard specification for testing floors.
- ❑ In 1917, Committee C-5 prepared a standard which was adopted in 1918 as a specification for “Fire Tests of Materials and Construction.”
 - Covered only floors and partitions.
 - Included a requirement of a maximum of 300 deg temperature rise on unexposed surface of partitions.
 - Established the time-temperature curve for conducting tests.
 - Was notable for the provision that structures be classified by their attained fire resistance.

(Extremely) Brief History of Fire Endurance Testing

The Beginnings of ASTM E 119

- ❑ In 1896, the Tariff Assoc. of New York, the Architectural League of New York and ASME, conducted tests of five columns and found failures to occur at temperatures less than 1500 deg. (Shoub)
- ❑ A series of tests conducted at Underwriters Laboratories with cooperation of the Associated Factory Mutual Companies and the National Bureau of Standards were underway in 1917 to 1918.
- ❑ The specification for Fire Tests of Building Construction and Materials, proposed in 1926 and adopted in 1933.
 - Provided for tests of columns.
 - Included a requirement of a maximum of 250 deg temperature rise on unexposed surface of partitions and floors based on NBS tests.

Criteria used to determine fire resistance ratings

ASTM E 119 - Standard Test Methods for Fire Tests of Building Construction and Materials

The ASTM E 119 Standard prescribes...

- Fire exposure (furnace time-temperature relationship)
- Measurement of furnace temperatures and specimen temperatures
- Size and construction of test specimens
- Protection and conditioning of test specimens
- Loading of test specimens
- Conduct of the test
- Conditions of Acceptance

Standard Methods of Fire Tests of Building Construction and Materials - ASTM Designation: E 119 – 61

- ❑ The ASTM E 119 - 61 conditions of acceptance address the following:
 - Resistance to passage of flame
 - Resistance to the transmission of heat through the floor
 - Structural soundness of the construction

Standard Methods of Fire Tests of Building Construction and Materials - ASTM Designation: E 119 – 61

Conduct of Fire Tests

- ❑ The fire endurance test on the specimen with its applied load, if any, shall be continued until failure occurs or until the specimen has withstood test conditions for a period equal to that herein specified in the conditions of acceptance for the given type of construction.

Conditions of Acceptance (Tests of Floors and Roofs)

- ❑ The test shall be regarded as successful if the following conditions are met:
 - The construction shall have sustained the applied load during the fire endurance test without passage of flame or gasses hot enough to ignite cotton waste, for a period equal to that for which classification is desired.
 - Transmission of heat through the construction during the fire endurance test shall not have been such as to raise the temperature on its unexposed surface more than 250 °F (139 °C) above its initial temperature.

Standard Methods of Fire Tests of Building Construction and Materials - ASTM Designation: E 119 – 00

Conduct of Fire Tests

- ❑ Continue the fire endurance test on the specimen with its applied load, if any, until failure occurs, or until the specimen has withstood the test conditions for a period equal to that herein specified in the conditions of acceptance for the given type of construction.

Tests of Floors and Roofs

- ❑ Two fire endurance classifications shall be developed from tests of assemblies restrained against thermal expansion;
 - Restrained assembly classification
 - Unrestrained assembly classification
- ❑ One fire endurance classification shall be developed from tests of assemblies not restrained against thermal expansion.

Standard Methods of Fire Tests of Building Construction and Materials - ASTM Designation: E 119 – 00

Conditions of Acceptance - Restrained Assembly Test

- ❑ In obtaining a restrained assembly classification, the following conditions shall be met:
 - The specimen shall have sustained the applied load during the classification period without developing unexposed surface conditions which will ignite cotton waste.
 - Transmission of heat through the specimen during the classification period shall not have been such as to raise the average temperature on its unexposed surface more than 250 °F (139 °C) above its initial temperature.

Standard Methods of Fire Tests of Building Construction and Materials - ASTM Designation: E 119 – 00

Conditions of Acceptance – Restrained Assembly Test

- ❑ In obtaining an unrestrained assembly classification, the following conditions shall be met:
 - For specimens employing steel structural members (beams, open-web steel joists, etc.) spaced more than 4 ft on centers, the temperature of the steel shall not have exceeded 1300°F (704°C) at any location during the classification period
 - nor shall the average temperature recorded by four thermocouples at any section have exceeded 1100°F (593°C) during the classification period.

Standard Methods of Fire Tests of Building Construction and Materials - ASTM Designation: E 119 – 00

Conditions of Acceptance - Unrestrained Assembly Test

- ❑ In obtaining an unrestrained assembly classification, the following conditions shall be met:
 - The specimen shall have sustained the applied load during the classification period without developing unexposed surface conditions which will ignite cotton waste.
 - Transmission of heat through the specimen during the classification period shall not have been such as to raise the average temperature on its unexposed surface more than 250 °F (139 °C) above its initial temperature.

Design and fabrication of test specimens

Design and fabrication of test specimens

Scaling of full-scale tests

- ❑ Aspects that cannot be scaled easily
 - Time
 - Temperature
 - Thermal properties of steel, concrete and fire-resistant material
 - Mechanical properties of steel, concrete
- ❑ Aspects that can be scaled
 - Size of members (e.g., cross-sectional area, thickness)
 - Geometry
 - Loading

Design and fabrication of test specimens

Test conditions of acceptance

- ❑ Temperature on unexposed surface of assembly
 - Thermal properties of concrete
 - Thickness of concrete
- ❑ Temperature of the steel (unrestrained rating)
 - Thermal properties of steel and fireproofing
 - Size of steel sections, thickness of fireproofing
- ❑ Sustain applied load
 - Mechanical properties of steel and concrete
 - Size of steel sections and thickness of concrete
 - Geometry of assembly
 - Loading

Design and fabrication of test specimens

Goal is to obtain same stresses in full- and half-scale tests

- ❑ Truss web members (diagonal bars) carry shear force
 - Stress in web members is a function of shear force and size of member
 - Shear force is a function of load and span
(Shear force \sim Load \times Span)
- ❑ Half-scale test assembly (span is one half that of full scale)
 - Span is one half
 - Members are full-size
 - Applied load is double

Design and fabrication of test specimens

Goal is to obtain same stresses in full- and half-scale tests

- ❑ Truss chord members and concrete slab carry bending moment
 - Stress in chord members and concrete is a function of bending moment and section modulus
(Stress \sim Bending Moment / Section Modulus)
 - Bending moment is a function of load and span squared
(Bending moment \sim Load \times Span²)
 - Section modulus is a function of size of members and geometry
- ❑ Half-scale test assembly...
 - Truss depth of one half leads to section modulus approximately one half of that in full-scale assembly

Design and fabrication of test specimens

Duplication of original conditions

- Geometry (including camber)
- Steel ASTM A242
- Welding
- Metal deck
- Primer paint
- Lightweight concrete
- Welded wire fabric
- SFRM material – Cafco DC/F

Design and fabrication of test specimens

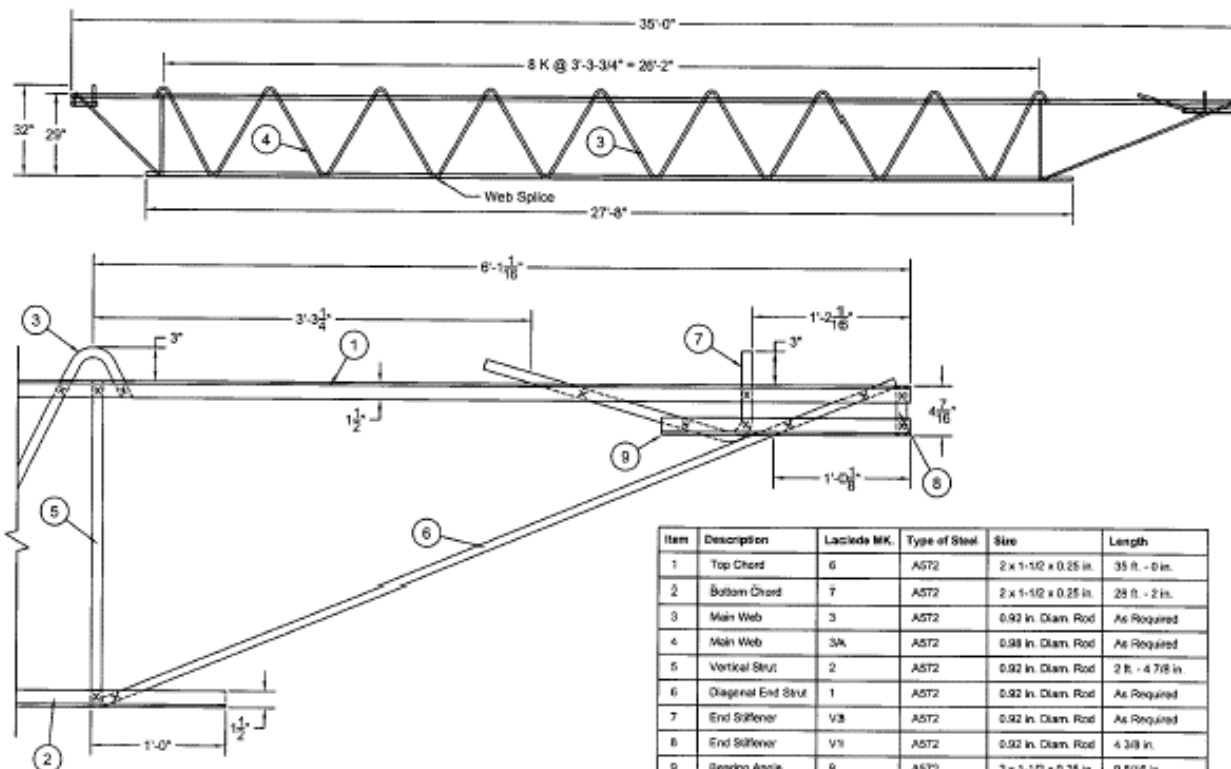

Item	Description	Lacida MK.	Type of Steel	Size	Length
1	Top Chord	6	A572	2 x 1-1/2 x 0.25 in.	35 ft. - 0 in.
2	Bottom Chord	7	A572	2 x 1-1/2 x 0.25 in.	28 ft. - 0 in.
3	Main Web	3	A572	0.92 in. Diam. Rod	As Required
4	Main Web	3A	A572	0.98 in. Diam. Rod	As Required
5	Vertical Strut	2	A572	0.92 in. Diam. Rod	2 ft. - 4 7/8 in.
6	Diagonal End Strut	1	A572	0.92 in. Diam. Rod	As Required
7	End Stiffener	V8	A572	0.92 in. Diam. Rod	As Required
8	End Stiffener	V1	A572	0.92 in. Diam. Rod	4 3/8 in.
9	Bearing Angle	9	A572	2 x 1-1/2 x 0.25 in.	9 5/16 in.
10	Vertical Strut Core Side	5	A572	0.98 in. Diam. Rod	As Required
11	Diagonal Strut	10	A572	0.98 in. Diam. Rod	As Required
12	End Stiffener	V2	A572	0.98 in. Diam. Rod	7 3/8 in.
13	End Stiffener	V1	A572	0.98 in. Diam. Rod	As Required

35'-0" Main Truss Column End Detail

CONFIDENTIAL-
DRAWN FROM INFORMATION
PROVIDED BY NIST

REVISED
SEP 25 2003
UNDERWRITERS
LABORATORIES INC.

MAINTRUSS35MLSHOP.DWG

On-site Monitoring and Inspection

NIST has overseen all aspects of the test program...

- Design and fabrication of test specimens

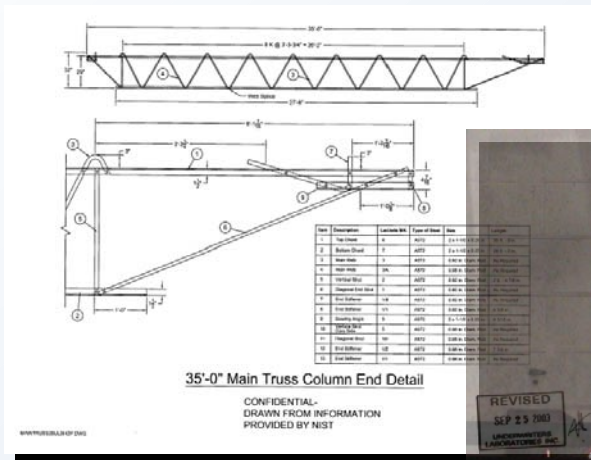

On-site Monitoring and Inspection

- Assembly of main and bridging trusses



On-site Monitoring and Inspection

- ❑ Casting of concrete slab and test cylinders, and curing and drying of concrete



On-site Monitoring and Inspection

- ❑ Primer Paint and Installation of Instrumentation



On-site Monitoring and Inspection

- Application of fireproofing



On-site Monitoring and Inspection

- ❑ Specimen loading



On-site Monitoring and Inspection

- ❑ Conduct of tests



Set-up of the UL fire tests

Set-Up of the UL Tests – Plan View

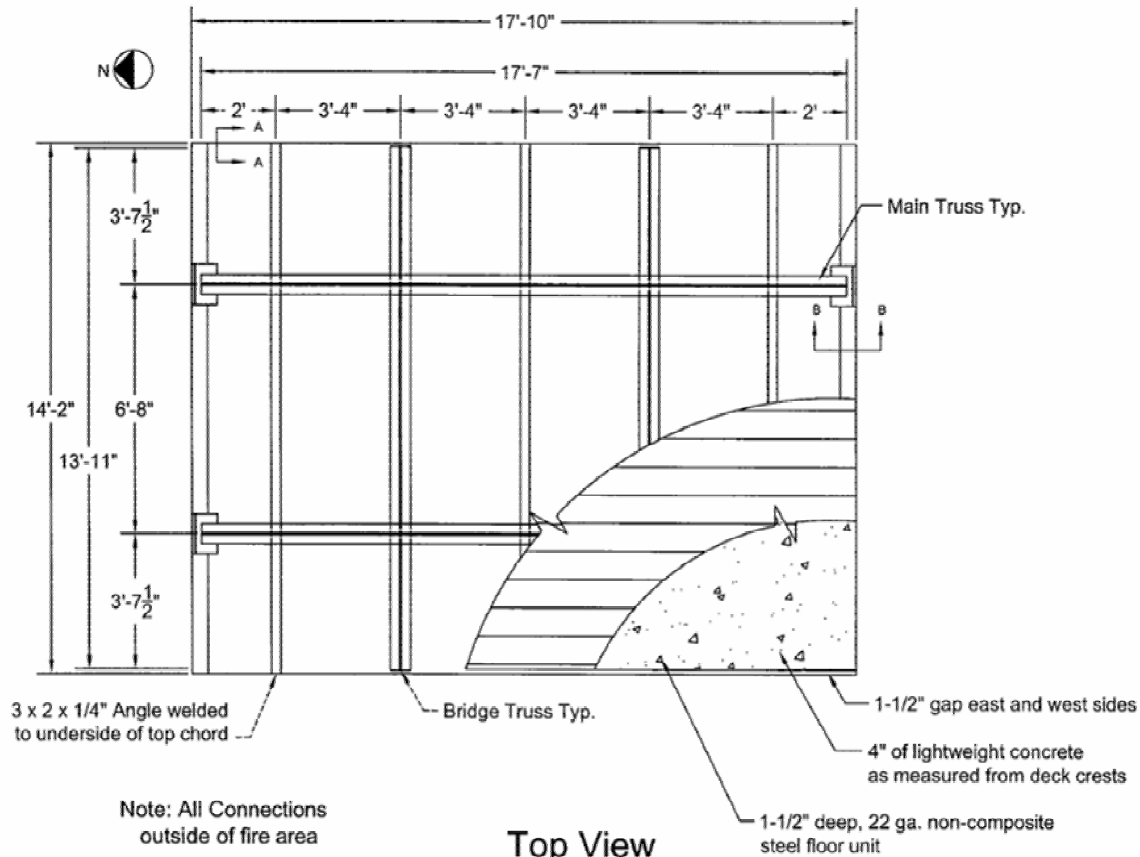

Top View Construction Details

CONFIDENTIAL-
DRAWN FROM INFORMATION
PROVIDED BY NIST

REVISED
JAN 05 2004
UNDERWRITERS
LABORATORIES INC.

UL CONSTR01.DWG

ILL. 9

Set-Up of the UL Tests - Loading



Set-Up of the UL Tests - Instrumentation

- ❑ **Temperature Measurements**
 - Steel trusses, top of concrete slab, underside of concrete slab (metal deck)
 - Exceed ASTM E119 requirements
- ❑ **Deflections**
 - Not required by ASTM E119
 - Top of slab and bottom chord of trusses
- ❑ **Gas Temperatures**
 - Exceed ASTM E119 requirements
- ❑ **Heat Flux**
 - Not required by ASTM E119

Preliminary observations from completed tests

Preliminary observations from completed tests

35 ft, restrained test

- ❑ Metal deck deflected downward (bulged) early in the test and continued to do so throughout the test.
- ❑ Deck deflection was generally accompanied by load “popping” sound
- ❑ Metal deck deflections likely due to concrete spalling



Preliminary observations from completed tests

35 ft, restrained test

- ❑ Bridging trusses buckled and distorted early in the test
- ❑ Post-test examination revealed buckling of compression diagonals
- ❑ Test assembly did not fail upon buckling of compression diagonals



Preliminary observations from completed tests (Cont'd)

35 ft, restrained test

- ❑ Failure to support load occurred when concrete failed suddenly, deflections increased suddenly, hot gasses escaped from furnace.
- ❑ Corners of slab did not deflect suggesting wedging action due to thermal expansion of slab prevented movement.
- ❑ Maximum deflection reached was approximately 14 in (3.3 % of span)

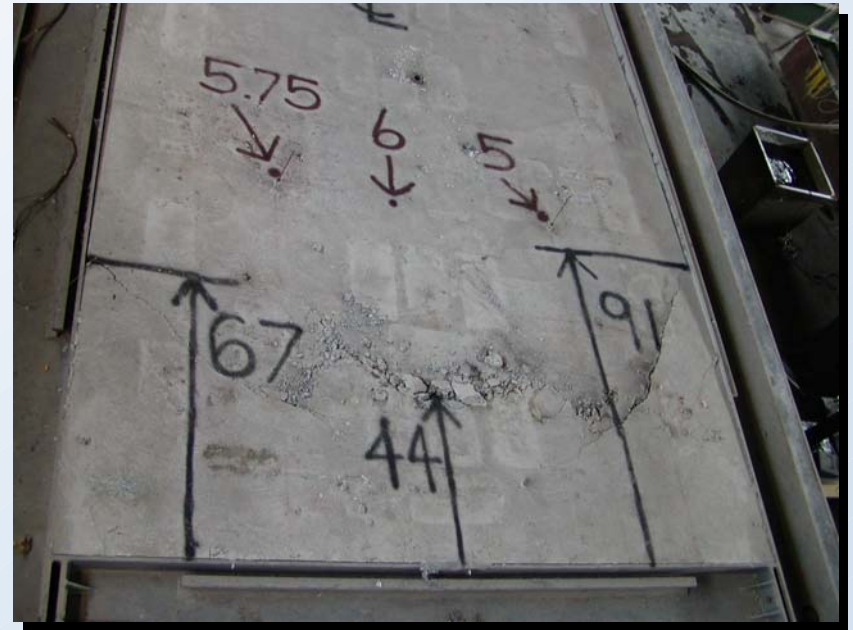

Preliminary observations from completed tests (Cont'd)

35 ft, unrestrained test

- ❑ Post-test examination revealed buckling of compression diagonals
- ❑ Bridging trusses buckled and distorted early in the test



Preliminary observations from completed tests (Cont'd)

35 ft, unrestrained test

- ❑ Vertical deflections occurred along entire span
- ❑ Minor cracking occurred in slab near corners
- ❑ Maximum deflection reached was approximately 13.5 in (3.2 % of span)



Laboratory Tour and Observing the Test

Video Cameras

- Furnace
- Top of test assembly

Data Display

- Temperatures
 - Top of slab (unexposed surface of floor)
 - Bottom of slab
 - Steel trusses (individual readings and average)
- Deflections
 - Top of slab
 - Bottom chord of steel trusses

Review of Code Provisions

Construction Classes – Unsprinklered

- ❑ Class 1A and 1B: NYC 68, NYS 64, BOCA 65 (Unlimited height)
- ❑ Class 1A,1B, 1C, 1D: NYC 01 (Height limited to 75 ft. unless sprinklered)
- ❑ Class 1A only: Chicago 67 (Unlimited height)

Fire Resistance Rating (all codes, except NYC 01)

❑ Class 1A

Columns: 4 hours (supporting more than one floor)

Beams : 3 hours (floor construction)

❑ Class 1B

Columns: 3 hours (supporting more than one floor)

Beams : 2 hours (floor construction)

❑ Class 1C

Columns: 2 hours (supporting more than one floor)

Beams : 1-1/2 hours (floor construction)

Mitigation of Potential Conflicts of Interest

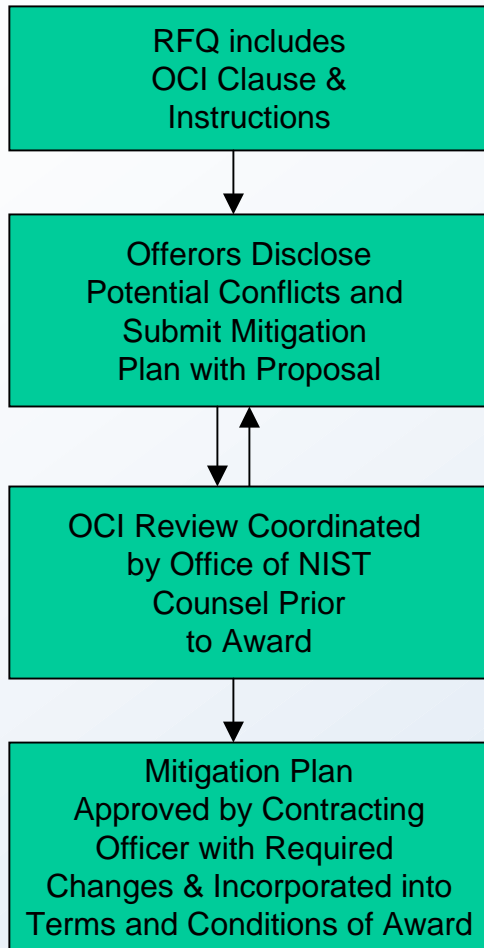

Organizational Conflicts of Interest

Requirement: Offerors must identify all business relationships in which they will provide data, research services or advice concerning the WTC disaster, including any involvement in related litigation. If any such relationship would constitute a real or apparent conflict of interest, they must provide a plan for mitigation of the conflict. Third party reviews of such plans may be required to assure that contract deliverables will be completely objective. These reviews may include, but are not limited to, other government agencies, non-profits, academia, or an independent contractor.

No contractor deliverables shall include findings, conclusions or recommendations.

Results (Ratings) of Tests to Date Using ASTM E119-2000

Conventional scale (17 ft span) - restrained

- Restrained Rating: 2 hours
- Unrestrained Rating: 1 hour

Full scale (35 ft span) - restrained

- Restrained Rating: 1 ½ hours
- Unrestrained Rating: 1 hour

Full scale (35 ft span) - unrestrained

- Unrestrained Rating: 2 hours

(Extremely) Brief History of Fire Endurance Testing

The Great Baltimore Fire

- ❑ On February 7, 1904, a fire broke out in the John E. Hurst wholesale dry goods house in the heart of Baltimore's business district. It moved rapidly through the building, and quickly spread to other buildings. (Washington Post Article, 2001)
- ❑ Fire departments from New York, Philadelphia and Washington, DC responded immediately to a desperate telegram sent by George W. Horton, chief engineer of the city's fire department.
- ❑ When the hoses would not fit Baltimore hydrants, the reinforcements were forced to watch helplessly as the flames spread, destroying approximately 1,500 buildings and burning for more than 30 hours.

Some Specific Questions

- ❑ How and why did WTC 1 stand nearly **twice** as long as WTC 2 before collapsing (103 min. vs. 56 min.) though they were hit by virtually identical aircraft?
- ❑ What factors related to **normal** building and fire safety considerations not unique to the terrorist attacks of September 11, 2001, if any, could have delayed or prevented the collapse of the WTC towers?
- ❑ Would the undamaged WTC towers have remained standing in a **normal** major building fire?
- ❑ What factors related to **normal** building and fire safety considerations, if any, could have saved additional WTC occupant lives or could have minimized the loss of life among the ranks of first responders?
- ❑ How well did the procedures and practices used in the design, construction, operation, and maintenance of the WTC buildings **conform** to accepted national practices, standards, and codes?