

FIRE SUPPRESSION IN **HUMAN-CREW** SPACECRAFT

Robert Friedman
National Aeronautics and Space Administration
NASA Lewis Research Center
Cleveland, Ohio 44135

Daniel L. Uietrich
Sverdrup Technology Inc.
Lewis Research Center Group
Brook Park, Ohio 44142

SUMMARY

Since fire prevention in spacecraft is never assured (minor fire incidents have, in fact, occurred), a second-line defense of fire extinguishment is essential. Early spacecraft were equipped with water and foam for extinguishing agents. The present Shuttle carries Halon 1301, despite its well known environmental and reaction-product problems. If an extinguisher were discharged during a Shuttle flight, the spacecraft would immediately be returned to Earth for clean-up of the atmosphere and affected surfaces. For the future U.S. Space Station Freedom, the specified agents are carbon dioxide in the U.S. laboratories and nitrogen in the **hyperbaric** (decompression) chamber. The major challenge to spacecraft fire extinguishment design and operations is from the low-gravity (microgravity) environment, which minimizes buoyant, **natural**-convective flows and profoundly influences extinguishment agent effectiveness, dispersal and post-fire cleanup. The paper discusses the experience and knowledge of extinguishment in microgravity, the fire-suppression **problems** anticipated in future spacecraft, and research needs and opportunities.

INTRODUCTION

A spacecraft in low-earth orbit, such as the U.S. Shuttle, experiences a free-fall condition, an environment popularly called zero gravity, but more correctly termed microgravity because slight residual accelerations or disturbances are always present. The strong, upward buoyant flow of hot combustion products observed in normal gravity is greatly reduced in **low**-gravity fires, thus affecting the mass and energy transport to the flame zone and the resulting fire characteristics (ref. 1). Microgravity fires in still air thus tend to be cooler and sootier than those in normal gravity and tend to spread slowly. On the other hand, microgravity fires under low-speed convective flow (ventilation, for example) have been observed in paper-fuel tests to have greater flammability limits and flame-spread rates than those in corresponding normal gravity (ref. 2). Furthermore, other studies suggest that smoldering materials in low gravity may readily transition to flaming combustion, due to reduced heat losses (ref. 3).

Several problems arise in preventive fire suppression **or** in extinguishment of established fires in spacecraft. Probable fire scenarios include fire situations that are difficult to access and penetrate (smoldering fires in waste containers, for example). The flame-cooling and oxygen-dilution effectiveness of agents may be reduced by the negligible natural convection and reduced mass and **energy** transport rates. The same changes in transport rates plus the strict mass, volume, and energy limitations can also present formidable problems in the design of effective agent storage and **de**livery systems. Finally, complete post-fire cleanup after extinguishment is critical in space, to prevent both immediate and long-term toxic and corrosive hazards.

The scope of this paper is the review of spacecraft fire-suppression concepts and practices, covering past and present spacecraft techniques, applicable findings in systems analyses and microgravity combustion science, proposed systems for the primary human-crew space mission of the future, the U.S. Space Station Freedom, and research needs and opportunities.

BACKGROUND

While materials for spacecraft should meet defined standards of low flammability, many common flammable materials, such as cotton toweling, paper products, films, sealants, and Velcro tabs, have no effective substitutes. Their use is permitted in spacecraft through waivers specifying inventory control and fire-protected storage. Furthermore, while obvious ignition sources are precluded, breakdowns of common equipment, such as heaters, electrical components, and friction devices, can provide potential ignition energy (refs. 1 and 4). Thus, the occurrence of minor fire incidents must be considered, and the second-line protection of fire detection and extinguishment is essential for spacecraft fire safety (refs. 1 and 5).

While experience has shown that present protection on the Shuttle is adequate, there is growing attention to the improvement of fire safety through research and technology. First, analyses and experiments on microgravity combustion science have strengthened the understanding and potential applications of this field (ref. 6). Second, changes in fire-safety practices outside the space field also influence the technology of space (the phasing out of Halon 1301 use is a good example, ref. 7). Finally, and perhaps most importantly, the approaching era of the extended duration missions of the Shuttle and Space Station Freedom demands improvements and innovations in fire safety, due to the complex nature of the anticipated designs and operations (ref. 8).

The earliest U.S. human-crew spacecraft had no dedicated systems for fire extinguishing. In the 100 percent-oxygen atmosphere of the Apollo spacecraft, the water-metering dispenser used for drinking and freeze-dried food reconstitution served as an emergency fire extinguisher (fig. 1). This water gun was never needed for fire extinguishment in space; this may be fortunate because the later Skylab tests of Kimzey demonstrated the difficulty of controlling and directing water sprays in space (ref. 9). The Apollo program also developed a foam extinguisher, which was included in the protection system of the original U.S. space station project, Skylab (fig. 2). This extinguisher generated a mixed-phase agent propelled by Freon and nitrogen gases. The fluid-flow behavior of the extinguisher was demonstrated in space but not its fire-fighting capabilities.

In the current U.S. Shuttle and its inhabited laboratory payloads (Spacelab and the future Microgravity Laboratories), a Halon 1301 system is provided. The Shuttle system consists of portable extinguishers plus fixed fire extinguishers installed in each of three electronic bays (fig. 3). Ports in the instrument panels permit the insertion of extinguisher nozzles for access to internal fires. The extinguishers have been discharged in space only for demonstration purposes.

The Halon 1301 fire-extinguishing system design on the Shuttle is an adaptation of systems used effectively in the cargo bays and other locations of aircraft. While external environmental contamination is immaterial in orbiting spacecraft, the use of Halon extinguishment creates long-term problems of toxic contamination and corrosion from the hydrogen halide reaction products, which are not easily removable by the spacecraft environmental-control system. Immediately after the discharge of an extinguisher on the Shuttle, however, a mission must be terminated and returned to earth within a few orbits. Thus, no substitute agent is under consideration for the Shuttle, because post-fire cleanup can be accomplished on the ground. For Space Station *Freedom* in a permanent orbit, the long-term atmospheric contamination and component corrosion problems from the reaction products cannot be ignored.

The review by Bluth (ref. 10) noted that there is a fire-extinguishing system in the only current operational space station, the Soviet Mir. A recent NASA inspection-trip report (Loftus,

J.P., et al., unpublished, December 1989) identifies the agent as a foam, perhaps similar to the agent used in the U.S. Skylab. A fire on the earlier Salyut 7 required both the discharge of an extinguisher and venting of the cabin atmosphere. The atmosphere of the uninhabited space station was replenished by a subsequent supply flight. Two minor incidents that occurred in the U.S. Shuttle missions were both the result of short circuits that caused overheating of wire insulation and brief smoldering. In each incident, the abnormal conditions were immediately observed by the crew, and the incipient fire was suppressed by deenergizing the appropriate circuits. The fire detectors did not actuate, nor was a fire extinguisher discharged.

SELECTION OF EXTINGUISHING AGENTS FOR SPACE

For spacecraft use, extinguishing agents must meet a strict set of physical requirements in addition to the effectiveness of fire suppression. There have been several system analyses or tradeoff studies to evaluate candidate extinguishing agents for spacecraft use, based on assessments of qualifications.

For the preliminary design of Freedom, a trade-off study (Opfell, J.: Fire Detection and Fire Suppression Trade Study, Allied-Signal Aerospace Co. report, unpublished, September 1985) ranked four candidate agents, carbon dioxide, Halon 1301, water, and nitrogen, on their response to a range of typical fire situations (NFPA Class A, B, and C, for example). The study assigned weights to 19 attributes for agent evaluation. As examples, the highest-weight attributes were risk (from use of the agent), reliability, accommodation to Freedom, developmental cost, initial cost, and crew usage. The selected agent, carbon dioxide, was on the basis of a slight numerical superiority, perhaps because the use of many attributes diluted the sensitivity of the analysis. A generic system study, based on a 1987 thesis by Sheridan (ref. 11), examined requirements for two spacecraft scenarios, extinguishment of a localized fire (NFPA Class A, B, or C) and suppression or explosion prevention of a large hydrogen fire (possibly from environmental-control system leakage). For the localized fire, the study ranked CO_2 , N_2 , dry chemicals, foam, Halon 1301, and deionized water for effectiveness, toxicity, system cost and mass, and technical readiness. For the large fire, the study limited the candidates to CO_2 , N_2 , and Halon 1301 and substituted module pressure buildup for toxicity. The results of the Sheridan analysis were the selection of CO_2 for the localized fire and Halon 1301 for the large fire. A recent analysis by Reuther (ref. 12) evaluated candidate agents of water, nitrogen, Halon 1301, carbon dioxide, and foam for a localized spacecraft fire scenario of smoldering, with respect to seven critical requirements, as well as flame-zone radiation effects. The preferred agent was again CO_2 . The study also selected N_2 for a scenario of atmospheric inerting to prevent explosion of a major hydrogen leak and fire, although this choice was a hypothesis because there were insufficient data for an effective analysis.

Table 1 is a summary of relevant selection factors for the three principal extinguishants, Halon 1301, CO_2 , and N_2 . Gaseous agents such as these have obvious advantages for delivery under space conditions. In the past, as noted, liquid water and mixed-phase agents have been specified for, if not actually used in, early spacecraft; and research proponents continue to urge research on nongaseous agents, such as water and mixed-phase foams (ref. 8).

EXPERIMENTAL STUDIES ON FIRE SUPPRESSION IN LOW GRAVITY

Early Tests

The original concern of studies of fire suppression for spacecraft was primarily for fire control in enriched-oxygen atmospheres and not necessarily for low-gravity control. Neustein

et al. (ref. 13) developed a nozzle design in 1968 that generated a hollow cone of nitrogen (or helium) to exclude oxygen from a fire zone for extinguishment in an enriched-oxygen, microgravity atmosphere. While some flammability tests were conducted in low-gravity, parabolic airplane flights, extinguishment tests on burning cloth samples were conducted only under normal-gravity conditions. Kimzey (ref. 9) conducted an extensive set of fire experiments in a combustion chamber with a 60 percent O_2 atmosphere on the U.S. space station Skylab in 1974. Until recently, these tests were the only combustion-related study conducted in a spacecraft. In the course of this study, Kimzey attempted to terminate some tests through two means of extinguishment, venting to vacuum and water sprays, with discouraging results. The vacuum venting intensified the fire through forced convection before extinguishing it. The water spray broke up into isolated droplets. Only a few droplets struck the burning material, and they tended to scatter the flaming material rather than extinguish the flame.

Studies with Halon 1301

With the introduction of Halon 1301 as the extinguishing agent in the Shuttle, small-scale tests were conducted on the effectiveness of this agent at the NASA Lewis Research Center (Haggard, J.B.: unpublished data, May 1975). Figure 4 shows the experimental results of extinguishment-limit boundaries for cellulose fuels at normal gravity. The test conditions encompassed the two Shuttle conditions: a normal atmosphere of 21 percent O_2 in N_2 (air), and a prebreathing atmosphere prior to an extravehicular activity of 40 percent O_2 (currently 30 percent) in N_2 at a reduced total pressure. An air flow of 11-cm/s velocity opposed to the flame spread represented the nominal flow of Shuttle ventilation. Naturally occurring buoyant air flows probably augmented the forced flow. The extinguishment limits are very sensitive to the imposed air velocity even at normal gravity. Figure 5 indicates that extinguishment boundaries reach maxima around 20 cm/s air velocity, where the greatest concentration of agent is required. There is an interesting comparison of these boundaries to recent microgravity results showing that flammability limits and flame-spread rates also reach maxima over a range of 8 to 20 cm/s opposed-flow velocities (ref. 2). The microgravity counterpart to figure 5, that is, the map of extinguishment maxima influenced by low-velocity opposed flows, has yet to be developed.

The cited studies also included still-air microgravity extinguishment limits obtained in free-fall, drop-tower experiments. Table 2 is a comparison of results from a series of tests. It shows that, for normal-pressure atmospheric air, only about half the quantity of agent is required for extinguishment in microgravity compared to that in normal gravity. At the low-total-pressure, enriched-oxygen condition, more agent is required for extinguishment, and the microgravity quantity is only slightly less than that in normal gravity. In contrast to these solid-fuel findings, Ronney (ref. 14) found little difference in Halon 1301 extinguishment limits between quiescent microgravity and normal-gravity, upward-burning cases, for the combustion of premixed methane-air mixtures.

Studies with Other Gaseous Extinguishants

Microgravity tests under air-dilution atmospheres serve to estimate nitrogen extinguishment requirements. Olson (ref. 15) reported an ignition limit of 16 mol % O_2 for downward burning of thin-paper fuels in normal gravity. This is equivalent to N_2 suppression by the addition of 31 mole percent N_2 to the original air atmosphere. The same test series showed an ignition limit of 21 percent O_2 in microgravity. Hence, only a trivial addition of nitrogen to air would suppress the paper flame in low gravity.

Figure 6 shows experimental results on the effect of several diluent atmospheres on microgravity flame-spread rates and flame-extinction limits, providing an estimate of the effectiveness of the diluents as extinguishing agents (ref. 16, with recent additions by Dietrich). The results shown are for tests under atmospheres with fixed O_2 partial pressures of 21 kPa (the air value) diluted with inert gas to reach the stated O_2 concentrations. Although the extinction limits shown are at differing total pressures (which may have only secondary effects on results), they are reasonable indicators of agent effectiveness. For example, roughly half the molar quantity of carbon dioxide (dilution to 33 percent O_2) accomplishes extinguishment compared to the quantity of N_2 (dilution to 21 percent O_2).

FIRE-EXTINGUISHMENT PROPOSALS FOR THE SPACE STATION *FREEDOM*

The focus of the U.S. space program is on the development of the Space Station Freedom, a multi-purpose community to be placed in a permanent low-Earth orbit for scientific, earth-observation, vehicle-tending, and commercial activities. A major objective of Freedom is to provide the environment for scientific and commercial research and developmental operations at a relatively large scale under microgravity. The need for greatly improved approaches to fire safety in Freedom is evident, due to the complexity of the spacecraft and its operations, the varied human and unattended activities proposed, and its long-term mission demanding fire control in place (refs. 4 and 8).

While many of the features of Freedom are still subject to change, the preliminary design of the fire-suppression system is generally established. The fire detection and suppression subsystem in Freedom falls under the Environmental Control and Life Support system (ECLSS). For the laboratory, habitation, and logistics modules under the responsibility of the United States, the preferred extinguishing agent is carbon dioxide, supplied from common storage or from portable extinguishers. Figure 7 is a representation of the laboratory module, which will be composed of four rack arrays around a central corridor. The extinguishing agent is stored in two redundant tanks in separate rack locations, interconnected to deliver CO_2 to any of the racks, the general arrays, or the corridor. Figure 8 shows the proposed agent delivery arrangement in a typical rack. The CO_2 agent is dispensed from a perforated tube to flood the rack upon actuation, through either a remotely controlled or a manual valve. A port in the fire detection and suppression panel permits insertion of a portable extinguisher nozzle, if necessary.

An obvious and often suggested technique to control major fires in space is through venting to the surrounding atmosphere. The small-scale tests of Kimzey (ref. 9) have already demonstrated that venting provides sufficient forced convection to increase the fire burning rate, a process that may continue for several minutes before the overall oxygen content is reduced. The gaseous supplies of Freedom are limited to slightly more than the quantity needed to support one evacuation and subsequent resupply cycle. Thus, venting to the environment is likely to be considered only as a last resort for an uncontrollable fire.

Fire safety, including fire-suppression provisions, on Freedom is also influenced by some of its unusual design features (Heitzman, J.; and Overmyer, C.: Space Station Freedom Contingency Operations Scenarios, McDonnell Douglas Astronautics unpublished report, April 1990). Freedom is an international program, and two of the laboratory modules are the responsibilities of the European Space Agency (ESA) and Japan. Table 3 lists the fire-suppression proposals for the three laboratories. In contrast to the centralized CO_2 system for the U.S. modules, the ESA laboratory specifies a Halon 1301 system, with individual supply bottles at each rack. The Japanese laboratory specifies a CO_2 system, also with individual bottles. Each international partner is

proceeding independently in its share of the design, but eventually some commonality of the fire-suppression systems must be devised. All of the modules will be interconnected through the data management system for alarm and reaction. The degree of automation and the tradeoffs between automated and manual decisions for extinguisher actuation are yet to be determined. Clearly, automatic agent release upon a false alarm or trivial incident may be as disastrous as a delayed manual response to an alarm. Furthermore, a fire may damage the automated data management system, forcing the dependence on manual response.

An additional design issue in Freedom is the hyperbaric chamber, located in an air lock, used to condition crew members for an extravehicular activity or to treat possible decompression sickness following such an activity. Because of the high pressure of several atmospheres and the human occupation of the chamber, the preferred agent for this chamber is nitrogen to be dispensed by flooding, to avoid toxic effects of carbon dioxide in large quantities.

CONCERNS AND RESEARCH NEEDS IN SPACECRAFT FIRE EXTINGUISHMENT

Carbon Dioxide Selection

As already noted, NASA and its prime contractor, Boeing Aerospace, prefer carbon dioxide for the Freedom internal module fire-extinguishing agent. While an unpublished 1985 trade-off study concluded that CO_2 showed a slight superiority, other qualitative factors promote its selection convincingly. Carbon dioxide extinguishing systems can use proven technology. The agent is removable from the atmosphere by the existing Environmental Control and Life Support System (ECLSS). Competing systems with N_2 , water, and Halons all suffer disadvantages of mass penalties, electrical conductivity, difficulty of dispersion, or toxic byproducts, as applicable. Carbon dioxide systems do require a larger storage mass than Halon 1301 due to the lower agent efficiency, but a CO_2 system may have a lower overall cost.

Two drawbacks to CO_2 usage are noted. First, local concentrations of CO_2 in a fire zone may approach 20 mol %, which is by far a toxic concentration especially in combination with a low concentration of carbon monoxide. Careful control of the discharge into racks can prevent excessive leakage of agent into the general volume of the module. For this reason, as mentioned, nitrogen is preferred for protection of the inhabited hyperbaric chamber. The second drawback is that, in the unlikely event of a major fire, stores of CO_2 may be insufficient. This may be a factor in the selection of Halon 1301 in the Sheridan analysis for the scenario of a large hydrogen fire (ref. 11). The probability of a combustible gas accumulation in Freedom from a leak in ECLSS processing, releasing hydrogen or methane byproducts, is small, however, for it requires multiple failures of containment, gas sensors, and ECLSS performance monitors.

Microgravity Extinguishment Research

Practical considerations of agent storage, dispersion, and post-fire cleanup in low gravity are selection factors as important as extinguishing effectiveness. The prototype CO_2 system for Freedom is to be qualified in prior ground tests for both effectiveness and reliability. Unfortunately, the correlation of the normal-gravity qualification to the eventual low-gravity performance is unknown, and appropriate experiments are critically needed.

Reuther (ref. 12) and Youngblood and Seiser (ref. 17) both propose experiments in a combustion chamber where a small-scale fire is initiated and then extinguished with candidate agents to measure the efficiency, delay time, effects of fuel type, likelihood to reignite, and reaction products for low-gravity extinguishment. Reuther suggests a flow system with multiple canisters of smoldering carbon for the experiment. Youngblood and Seiser suggest a sample-exchange system

for solid fuels in a quiescent or a flowing atmosphere. Either experiment proposal is designed to investigate a variety of gaseous or liquid-spray (water) agents. These studies can be initiated in sounding rocket or airplane free-fall facilities, prior to space flight experiments.

Youngblood and Vedha-Nayagam (ref. 18) also identify further applied research and technology development in the field of space extinguishment. Suggested projects include specific research on extinguisher performance in inhabited hyperbaric chambers, applied technology on high-capacity environmental clean-up units for post-fire applications, and development of innovative space fire protection, such as fire blankets.

CONCLUDING REMARKS

This paper is a review of past, present, and proposed techniques for fire suppression in spacecraft. While fire events may be of low probability, present human-crew spacecraft are provided with fire protection including extinguishers. The low-gravity environment in orbiting spacecraft influences combustion, heat transport, and mass transport, greatly affecting extinguishment agent effectiveness, storage, dispersion, and clean-up system performance. The increasing complexity anticipated with the advent of the U.S. Space Station Freedom also complicates the issues of spacecraft fire extinguishment. The current application of Halon 1301 agent in the Shuttle is justified by the nature of the short-term missions, but alternative agents are essential for Freedom. Clearly, continued research and technology activities should be directed toward securing knowledge of the unusual features of fires in space for application to practical, effective, and conservative spacecraft fire suppression systems.

REFERENCES

1. Friedman, R.; and Sacksteder, K.R.: Science and Technology Issues in Spacecraft Fire Safety. AIAA Paper 87-0467, Jan. 1987. (Also, NASA TM-88933).
2. Olson, S.L.; Ferkul, P.V.; and T'ien, J.S.: Near-Limit Flame Spread Over a Thin Solid Fuel in Microgravity. Twenty Second Symposium (International) on Combustion, The Combustion Inst., Pittsburgh, 1988, pp. 1213-1222.
3. Cantwell, E.R.; and Fernandez-Pello, A.C.: Smoldering Combustion Under Low Gravity Conditions. AIAA Paper 90-0648, Jan. 1990.
4. Friedman, R.; and Sacksteder, K.R.: Fire Behavior and Risk Analysis in Spacecraft. NASA TM-100944, 1988.
5. Rodney, G.A.: Critical Safety Assurance Factors for Manned Spacecraft: A Fire Safety Perspective. IAF Paper 90-555, Oct. 1990.
6. Law, C.K.: Combustion in Microgravity: Opportunities, Challenges and Progress. AIAA Paper 90-0120, Jan. 1990.
7. Friedman, R.; and Olson, S.L.: Fire Safety Applications for Spacecraft. "Aircraft Fire Safety, AGARD CP-467. AGARO, Nevilly-Sur-Seine, France, 1989, pp. 15-1 to 15-15. (Also, NASA TN-101463).

8. Margle, J.M., ed.: Spacecraft Fire Safety. NASA CP-2476, 1986.
9. Kimzey, J.H.: Skylab Experiment M479 Zero Gravity Flammability. Skylab Results, Proceedings of the Third Space Processing Symposium, Vol. 1, NASA TMX-70252, June 1974, pp. 115-130.
10. Bluth, B.J.; and Helppie, M.: Soviet Space Stations as Analogs, 2nd edition. NASA-CR 180920, 1987.
11. Kramer, S.; and Sheridan, J.: Preliminary Analysis of Fire Suppression Methods for the Space Station. Engineering, Construction, and Operations in Space, SW. Johnson and J.P. Wetzel, eds., ASCE, New York, 1988, pp. 809-819.
12. Reuther, J.J.: Definition of Experiments to Investigate Fire Suppressants in Microgravity. NASA CR-185295, 1990.
13. Neustein, R.A.; Mader, P.P.; Columbo, G.V.; and Richardson, D.E.: The Effect of Atmospheric Selection and Gravity on Burning Rate and Ignition Temperature. McDonnell Douglas Astronautics Co., Report DAC-62431. NASA CR-106652, Oct. 1968.
14. Ronney, P.D.: Effect of Gravity on Halocarbon Flame Retardant Effectiveness. Acta Astronautica, vol. 12, no. 11, 1985, pp. 915-921.
15. Olson, S.L.: The Effect of Microgravity on Flame Spread Over a Thin Fuel. NASA TM 100195, 1987.
16. Olson, S.L.; Stouffer, S.C.; and Grady, T.: Diluent Effects on Quiescent Microgravity Flame Spread Over a Thin Solid Fuel. Paper 70, Fall Tech. Mtg., Eastern States Sec., The Combustion Inst., Nov. 1989.
17. Youngblood, W.W.; and Seiser, K.M.: Experiments to Ensure Space Station Fire Safety - A Challenge. AIAA Paper 88-0540, Jan. 1988.
18. Youngblood, W.W.; and Vedha-Nayagam, M.: Advanced Spacecraft Fire Safety: Proposed Projects and Program Plan. (WYLE-60300-1, Wyle Labs; NASA Contract NAS3-25367) NASA CR-185147, 1989.

TABLE 1. - CANDIDATE EXTINGUISHING AGENTS FOR SPACECRAFT

	Status	Advantages	Disadvantages
Halon 1301	Current use on Shuttle, Spacelab	Very effective in small quantities; nontoxic, non-corrosive in unreactive form	May not be available in future (environmental concerns); toxic and corrosive products
Carbon dioxide	Proposed for S ₄ Freedom modules	Excess easily removable by current environmental controls; nontoxic products; state-of-the-art systems	Relatively ineffective; agent toxic in large concentrations
Nitrogen	Proposed for hyperbaric chamber	Already available in large quantities; nontoxic products; compatible with current life-support systems	Very ineffective (large quantities required); use may require venting to avoid overpressures

TABLE 2. - COMPARISON OF HALON EXTINGUISHMENT REQUIREMENTS FOR 0.037-mm-THICK PAPER

Total pressure, kPa	Oxygen mole fraction	Gravity level	Range of Halon 1301 mole fraction for extinguishment
101	0.21	Normal	0.09-0.10
101	.21	Microgravity	.05-.06
55	.39	Normal	.18-.20
55	.39	Microgravity	.12-.15

TABLE 3. - COMPARISON OF FIRE-SUPPRESSION SYSTEMS FOR FREEDOM INTERNATIONAL MODULES

	II C	ESA	Japan
Suppression agent	Carbon dioxide	Halon 1301	Carbon dioxide
Distribution agent	Centralized carbon dioxide tanks	Distribution bottles	Distribution bottles

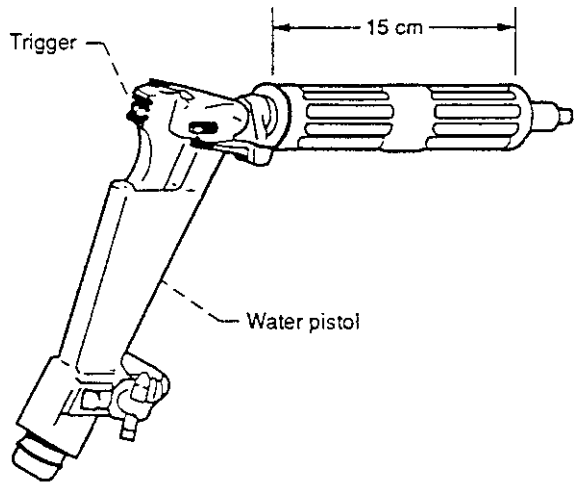

Figure 1.—Apollo water-dispenser fire extinguisher.

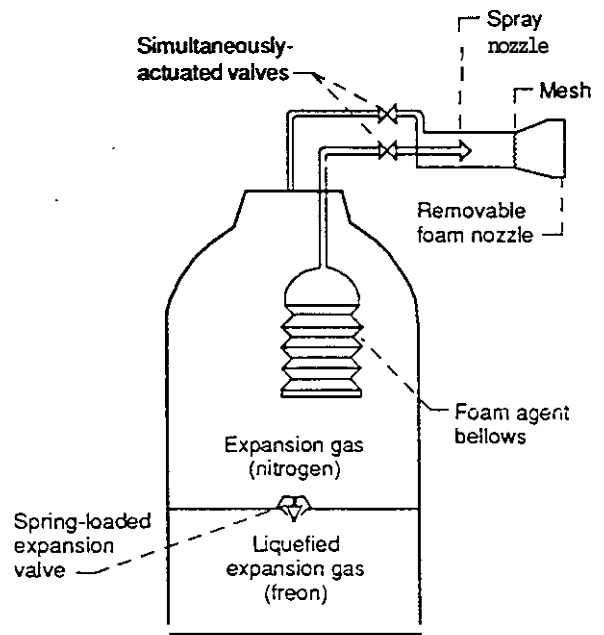
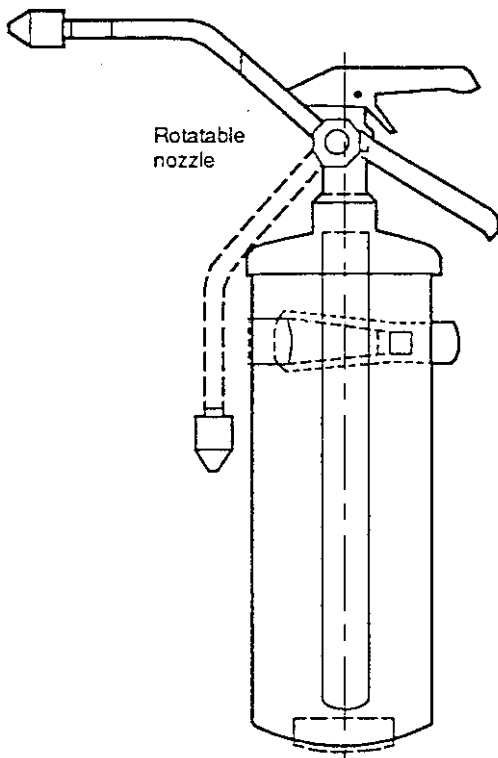
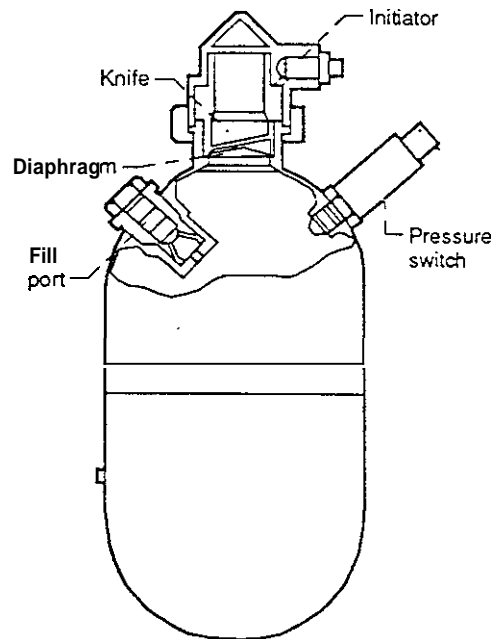

Figure 2.—Apollo Skylab foam fire extinguisher.



Portable:
Halon charge 3 kg;
discharge time 30 sec



fixed:
Halon charge 1.7 kg;
discharge time 1 sec

Figure 3.—Shuttle Halon 1301 fire extinguishers.

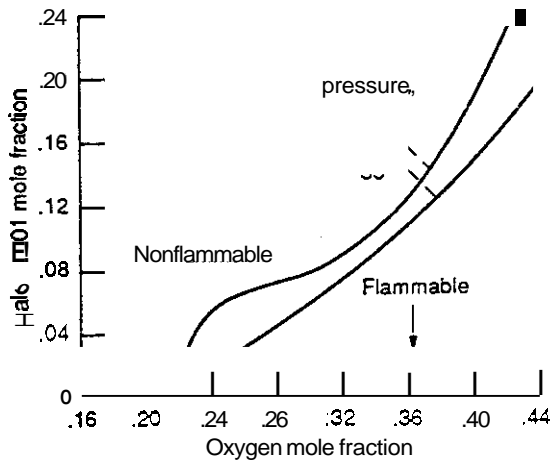

Figure 4.—Experimental extinguishment boundaries for 0.21 mm thick cellulose in Halon 1301-oxygen-nitrogen atmospheres. Normal-gravity conditions with 11 cm/s opposed atmospheric flow (from J.B. Haggard, unpublished data, 1975).

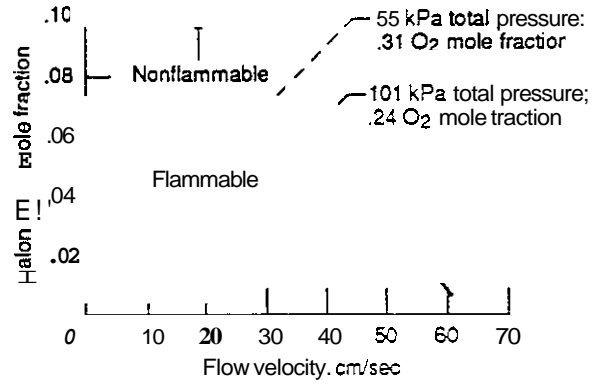

Figure 5.—Experimental effects of opposed atmospheric flow velocities on extinguishment boundaries for 0.21 mm thick cellulose. Normal-gravity conditions (from J.B. Haggard, unpublished data, 1975).

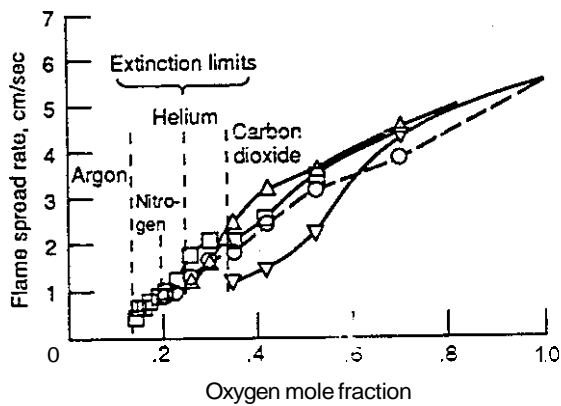

Figure 6.—Experimental flame spread rates for 0.076 mm thick paper under different oxygen-diluent atmospheres. Quantities are microgravity conditions with oxygen quantity fixed at 21 kPa partial pressure (air value).

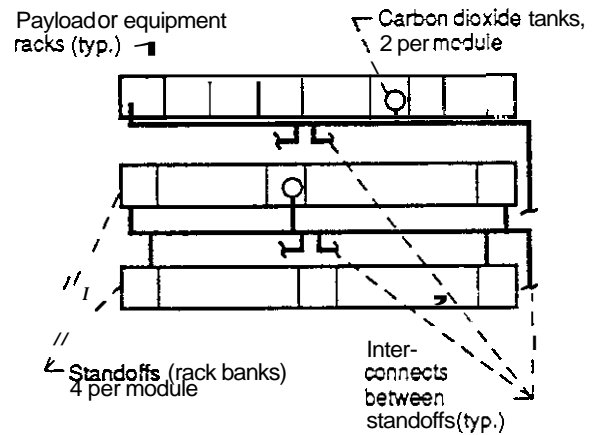

Figure 7.—Schematic representation of centralized carbon dioxide extinguishing system in U.S. modules for Space Station Freedom.

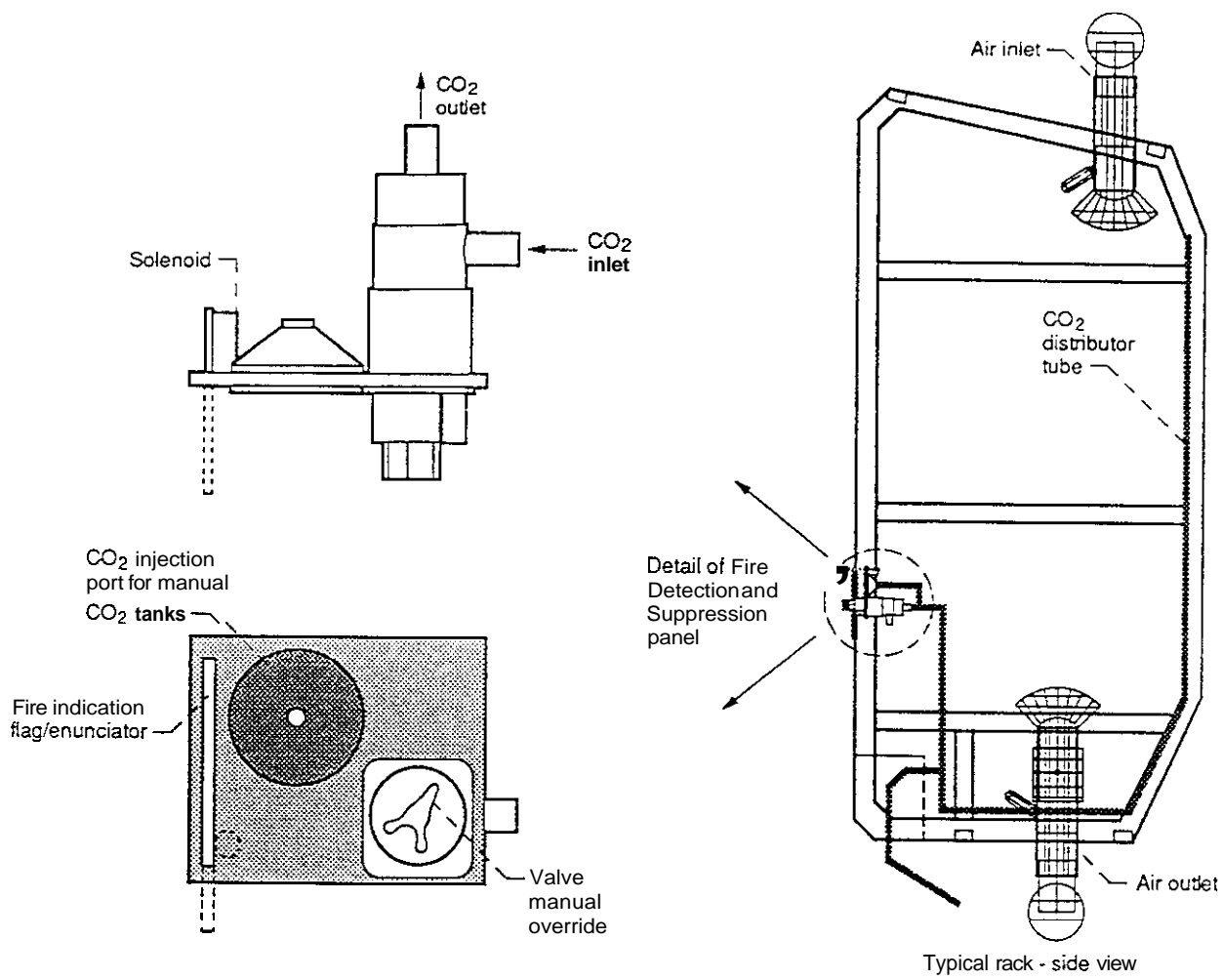

Figure 8.—Proposal for carbon dioxide control and distribution within a module rack for Space Station Freedom (Boeing Aerospace design).

Fire Suppression in Human-Crew Spacecraft

**Robert Friedman
NASA Lewis Research Center**

and

**Daniel L. Dietrich
Sverdrup Technology Inc.**

**Halon Alternatives Technical Working Conference
Albuquerque, New Mexico**

April 30 - May 1, 1991

Fire Suppression in Human-Crew Spacecraft

Outline

Background and brief history

Selection of extinguishing agents for space

- **Systems analyses**
- **Experimental studies**

Proposals for future spacecraft - Space Station Freedom

Concerns and research needs

CD-01-52417

Fires in Space

- **ON EARTH AND IN AIRCRAFT, FIRE SPREAD IS SUPPORTED THROUGH BUOYANT FLOWS, DRIVEN BY NORMAL-GRAVITY FORCES**
- **IN ORBIT, SPACECRAFT EXPERIENCE NEGLIGIBLE GRAVITY FORCES AND BUOYANT FLOWS**
- **IN THE ABSENCE OF BUOYANT FLOWS, OTHER HEAT AND MASS TRANSFER MECHANISMS DOMINATE; HENCE IGNITION, FIRE SPREAD, AND FLAME CHARACTERISTICS ARE DIFFERENT IN SPACE**

SOLID-MATERIAL FLAMES IN SPACE

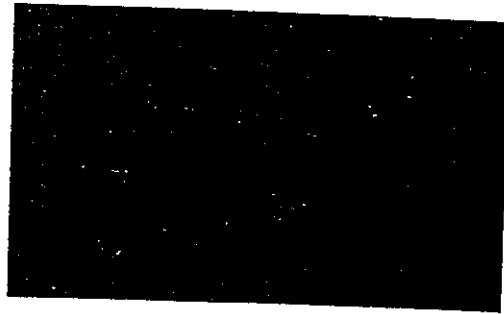

LOW GRAVITY, QUIESCENT



LOW GRAVITY,
VENTILATION-ASSISTED

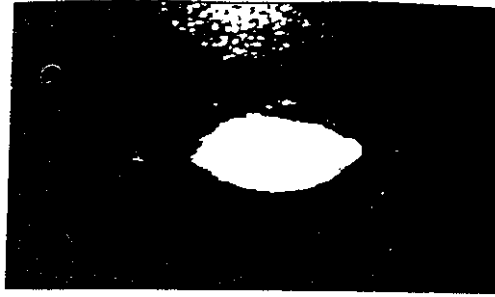

NORMAL GRAVITY
REFERENCE

Factors Influencing Future Spacecraft Fire Safety

- LONG-DURATION MISSIONS INCREASE PROBABILITY OF FIRE EVENTS IN SPACE
- LACK OF OUTSIDE RESCUE COMPLETES FIRE FIGHTING AND RECOVERY
- COMPLEX AND VARIED ACTIVITIES ON THE SPACE STATION FREEDOM MAY MAKE FIRE PREVENTION AND CONTROL MORE DIFFICULT (LARGER VOLUMES TO PROTECT, PERIODS OF UNATTENDED OPERATION, ETC.)

SPACE STATION FREEDOM MODULE PATTERN

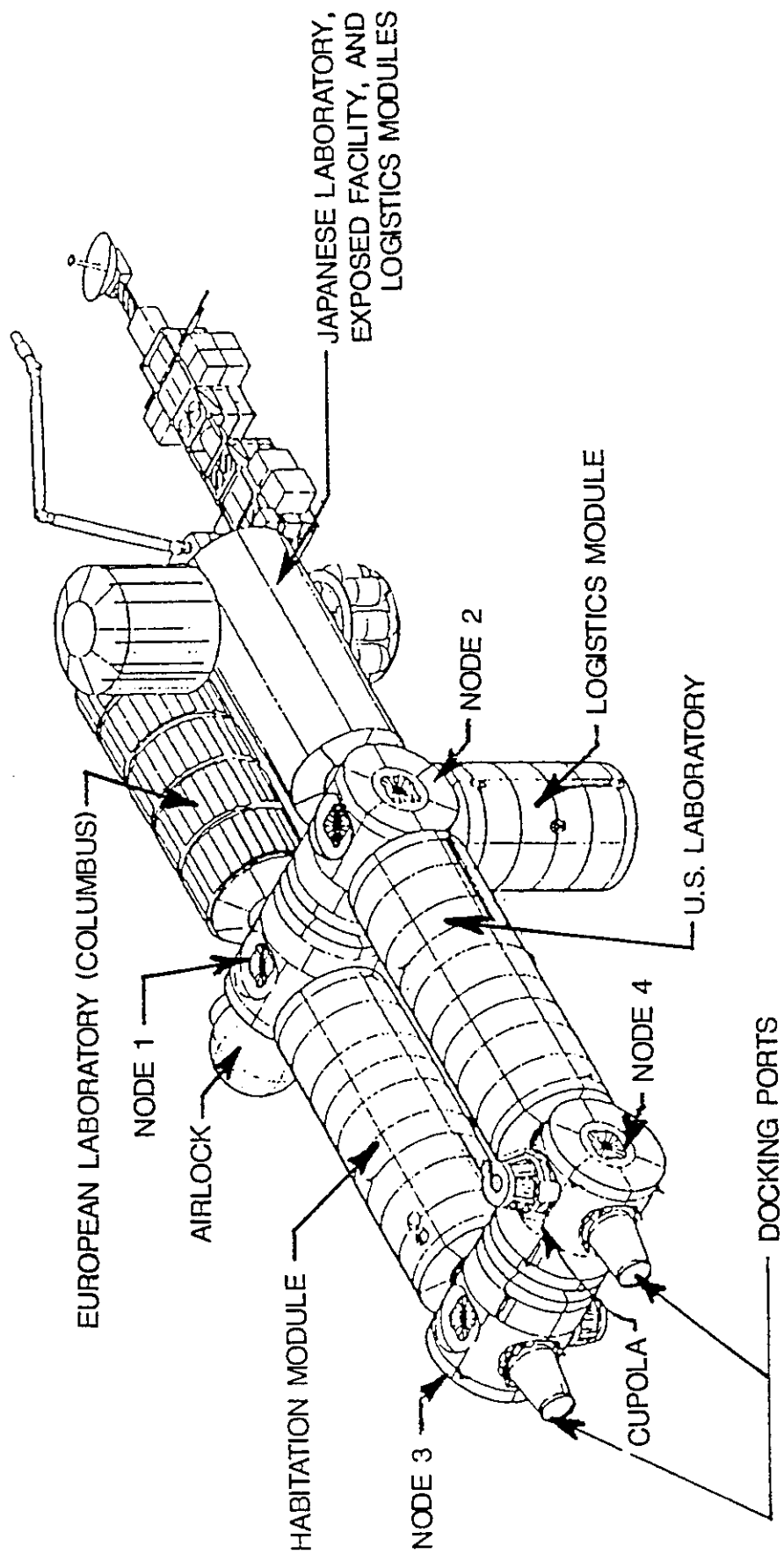

**SPACE STATION FREEDOM
FIRE PROTECTION MONITORING**

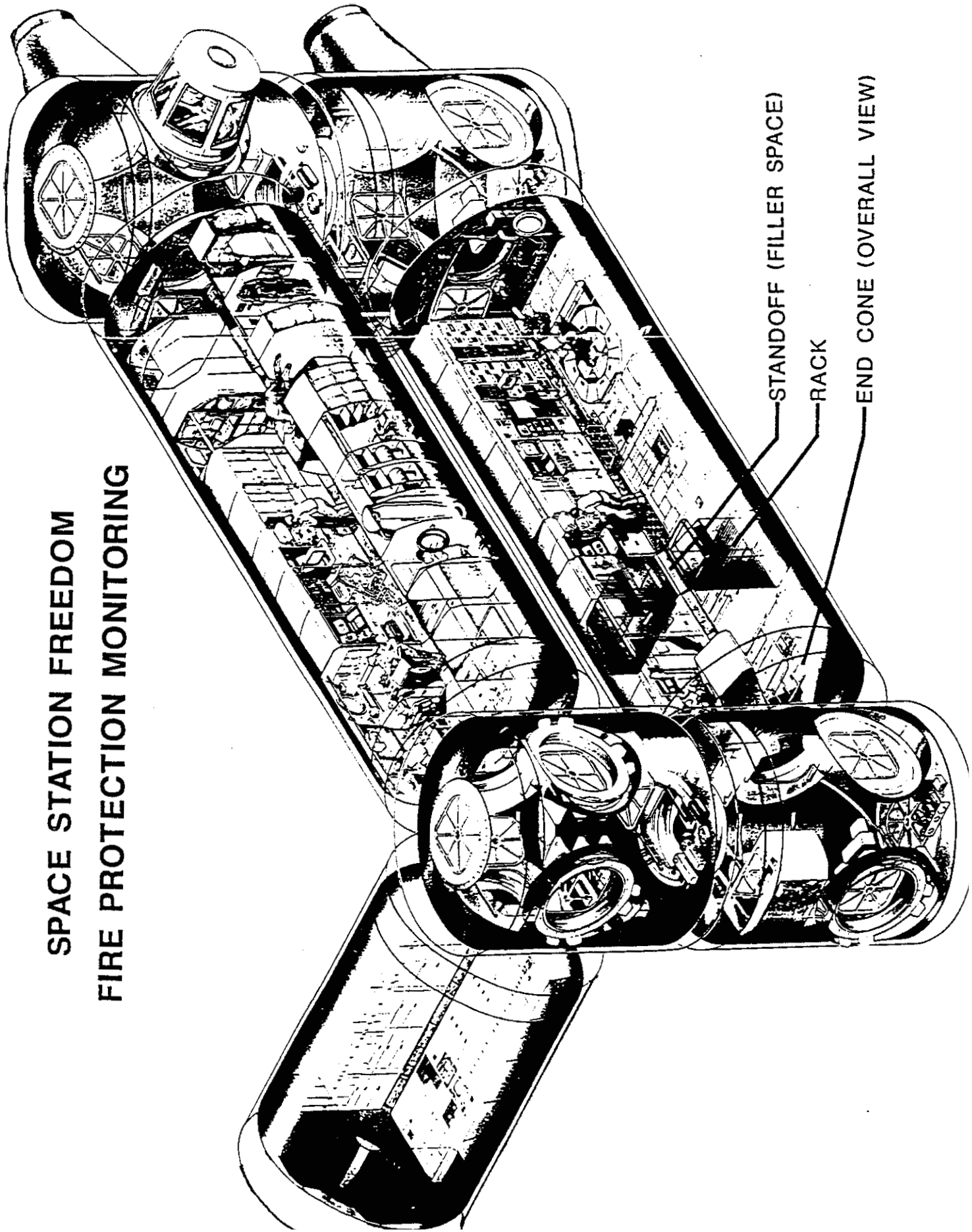

Research and Applications Concerns for Fire Extinguishment in Future Spacecraft

Limited understanding of potential fire scenarios and microgravity fire processes

Compromises necessity in selection of agents

Non-commonality in system designs among Freedom international partners

Major fire control: venting and atmospheric replenishment

Physical management of agents: storage and dispersal

Post-fire cleanup of atmosphere and surfaces

Fire Suppression in Human-Crew Spacecraft Concluding Remarks

While first line of defense is fire prevention, fire-extinguishing systems are essential for spacecraft

Alternates to Halon 1301 are necessary on spacecraft to reduce operational problems, rather than for external environmental protection

The microgravity environment in orbiting spacecraft profoundly affects combustion and extinguishment processes

In addition, microgravity affects the physical management of extinguishing agent storage, dispersal, and post-fire cleanup

Continued research and technology are necessary to improve understanding and to direct applications to practical, effective, and conservative systems for space

FIRE EXTINGUISHMENT IN THE SHUTTLE

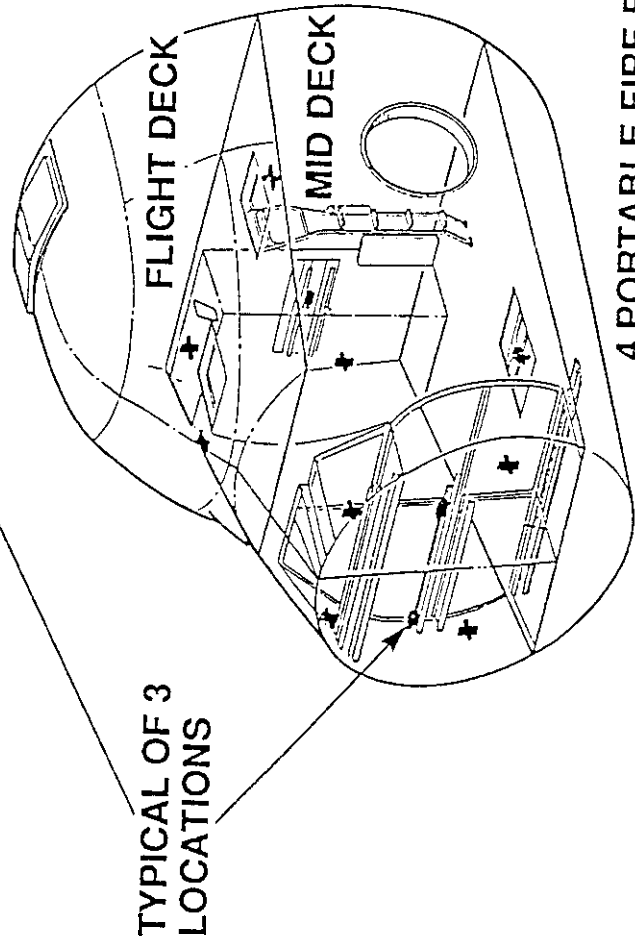
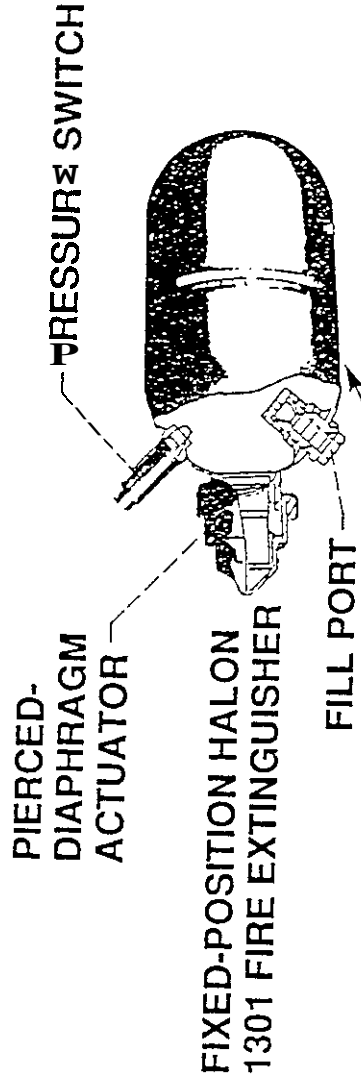

4 PORTABLE FIRE EXTINGUISHERS NOT SHOWN

CD-89-39709