

# The problem of the value of the Newtonian constant of gravitation, $G$

Terry Quinn

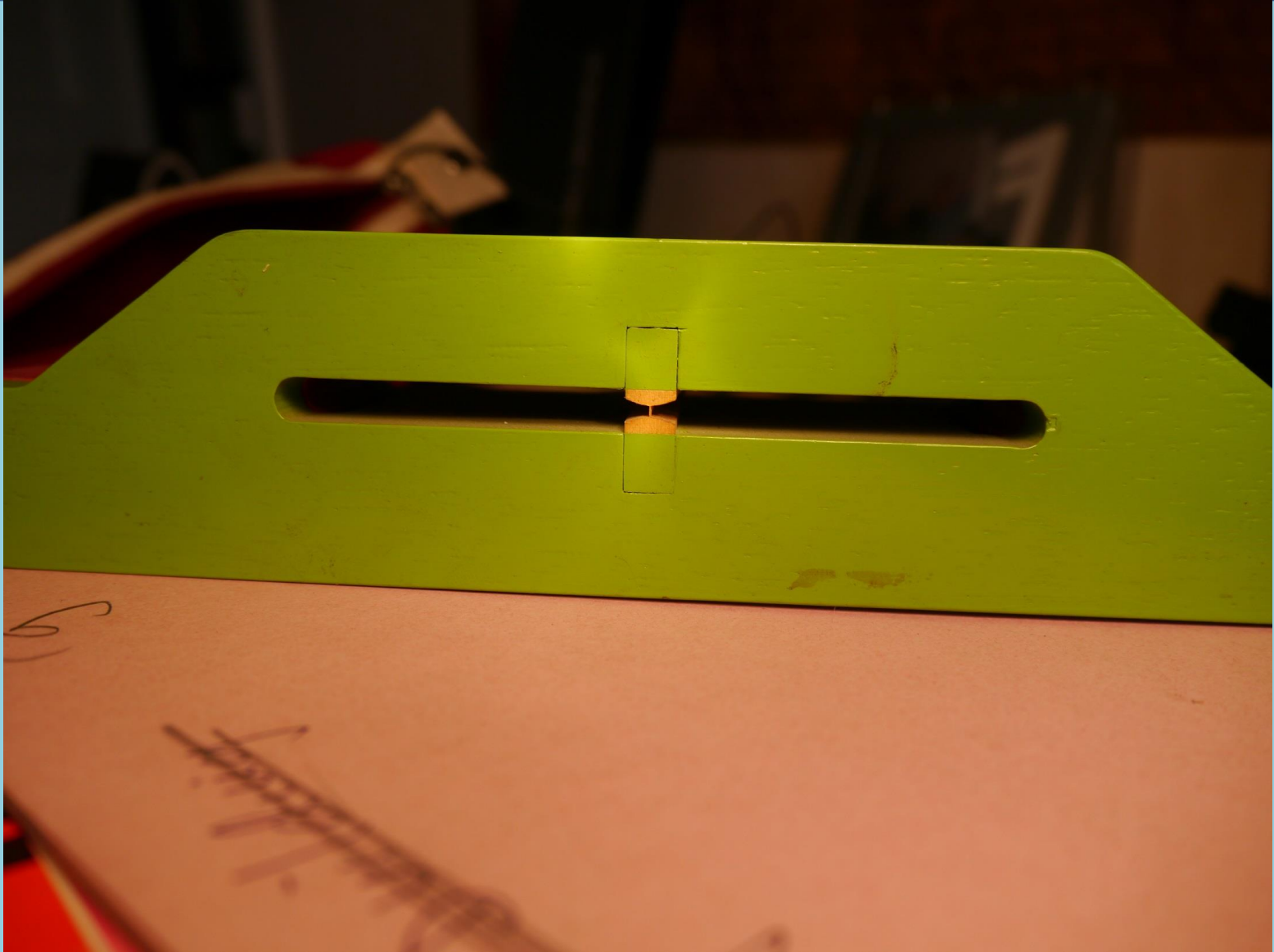

Wood model of a flexure-strip balance designed to be cut from the solid, NPL 1975



View showing one end of the the flexure

View showing flexures attached A to the base and B to the beam (these flexures are actually broken)

Similar sets of flexures were designed to be cut into the beam at its ends.

On moving to the BIPM in 1977, attempts to make a complete beam like this failed and I was told it was impossible!

Today, with 3D printing it might be different.

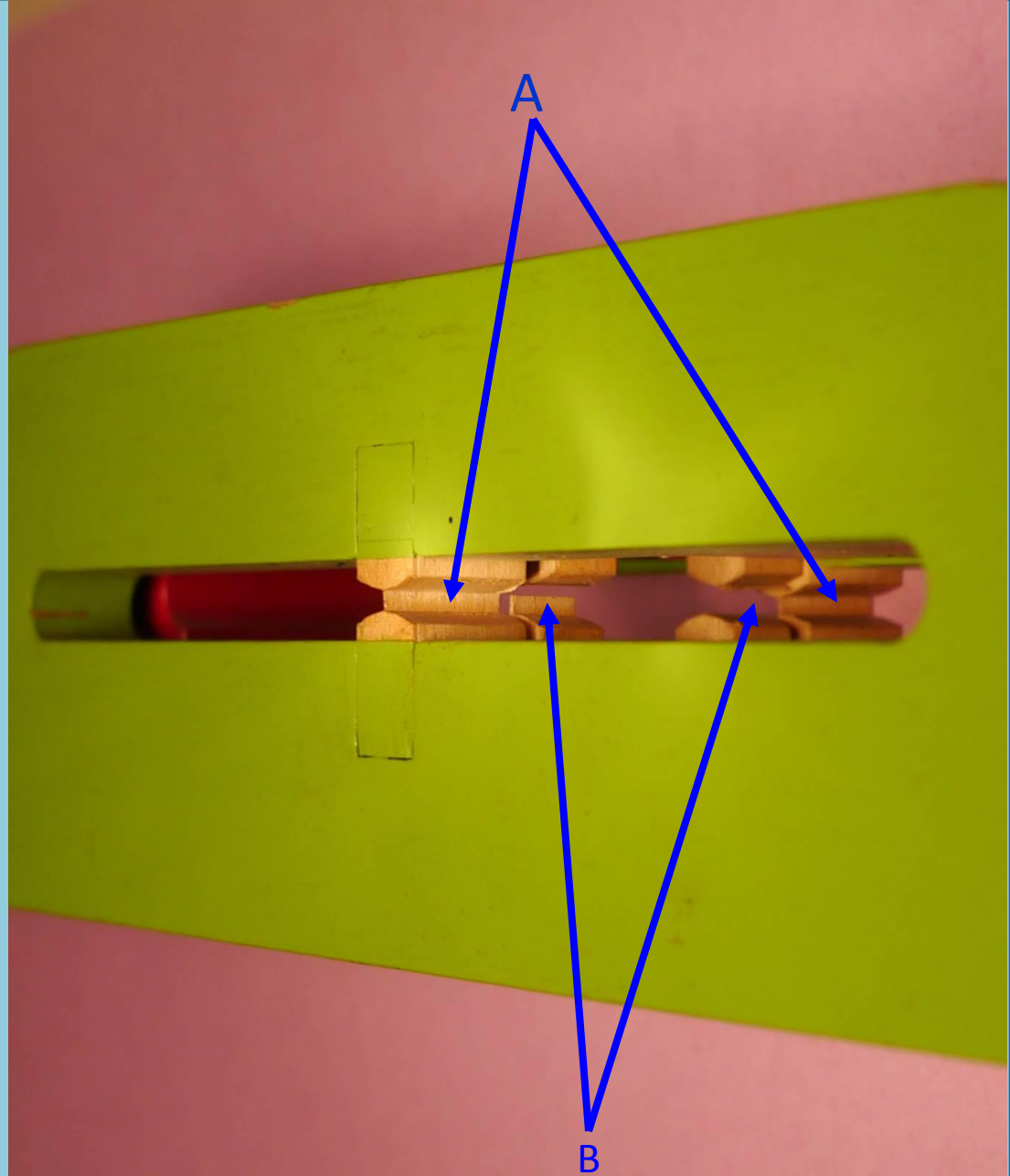

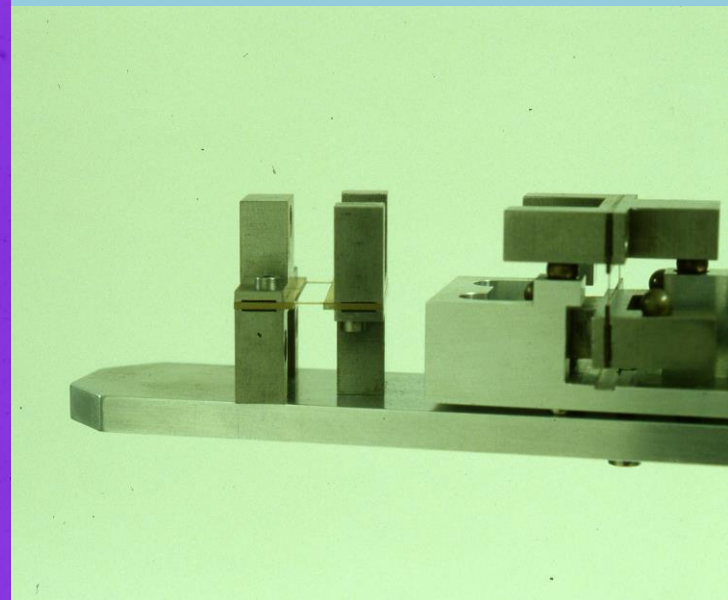
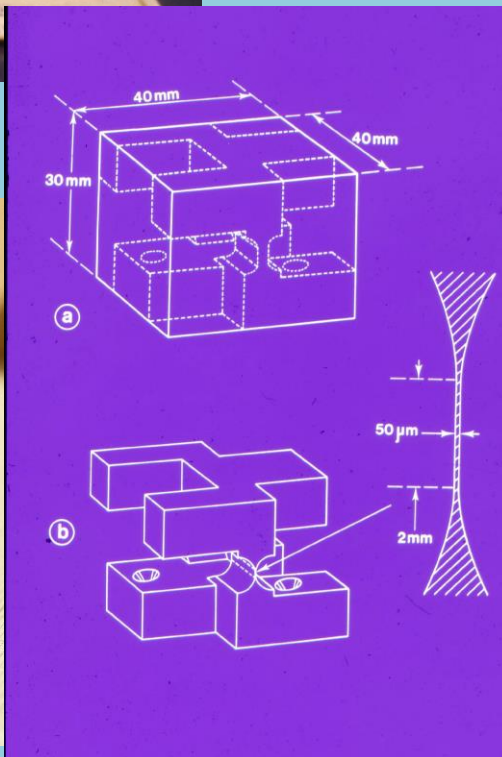
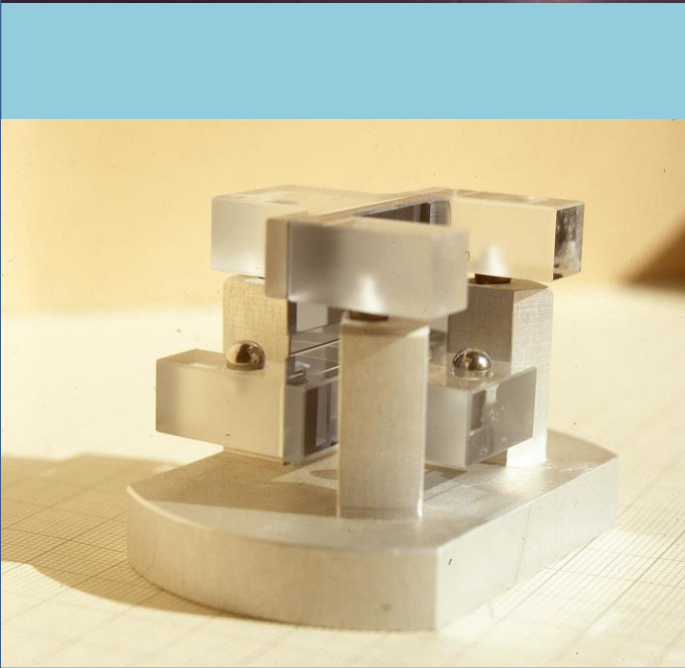
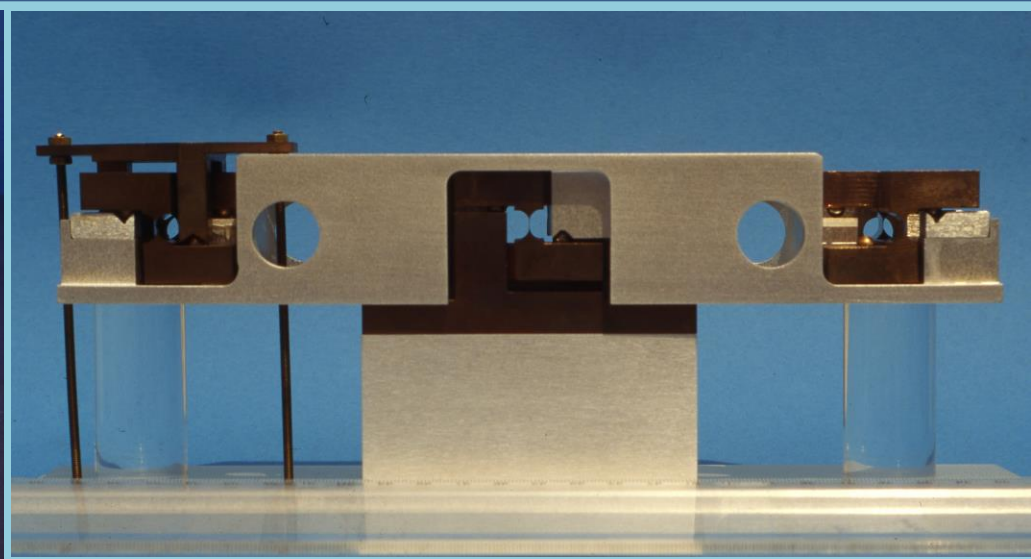
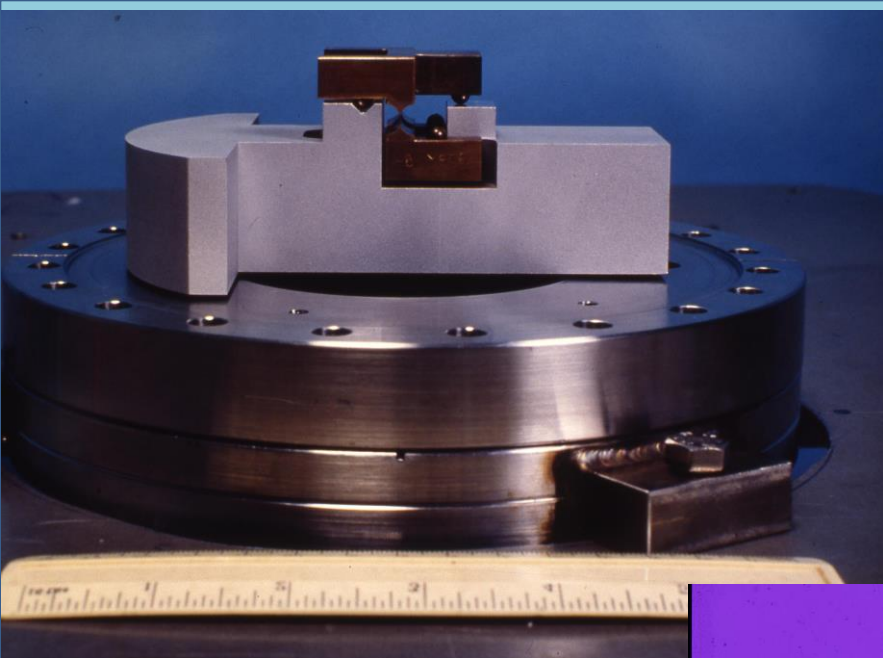

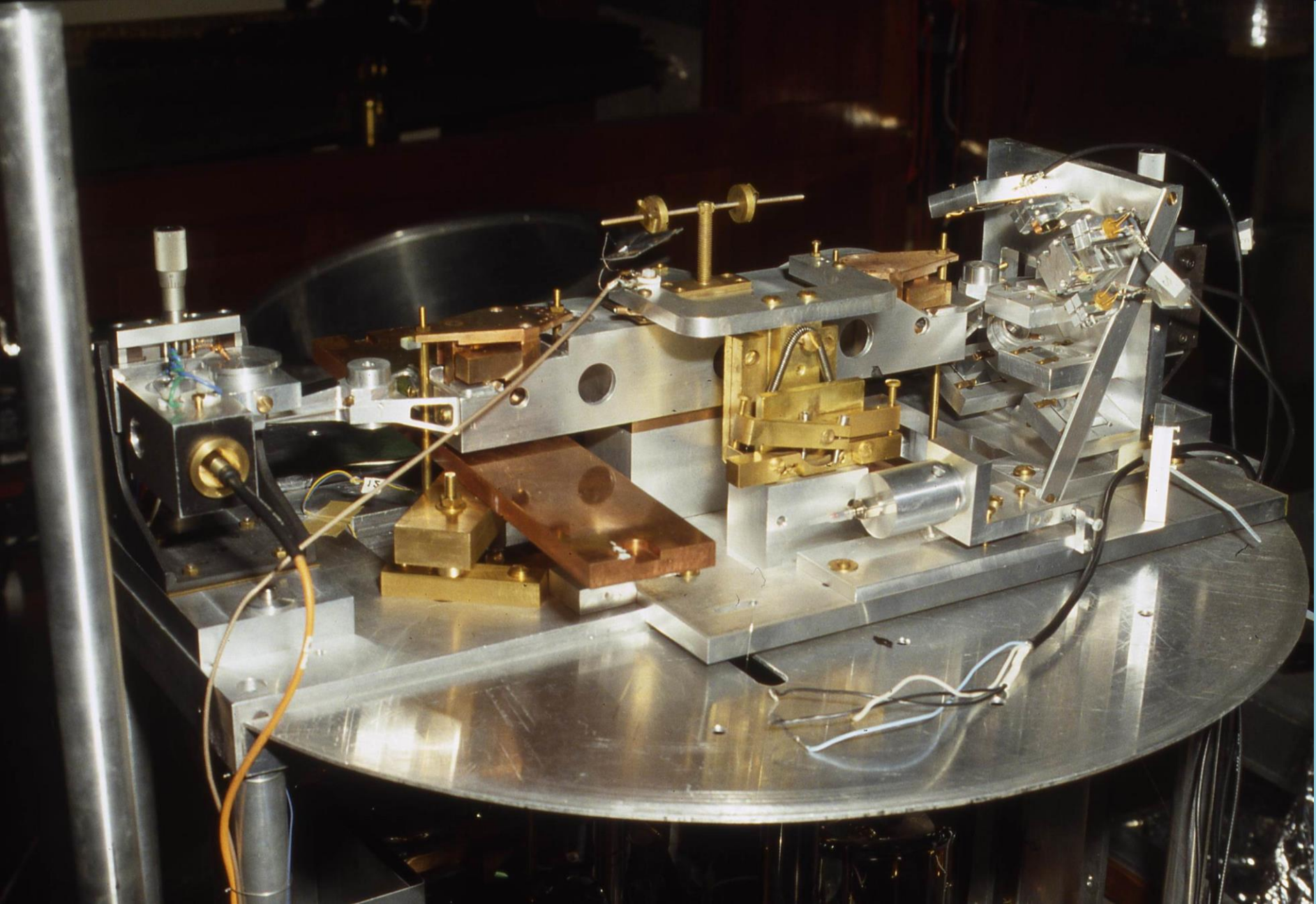

The beam of the first BIPM flexure-strip balance, 1988

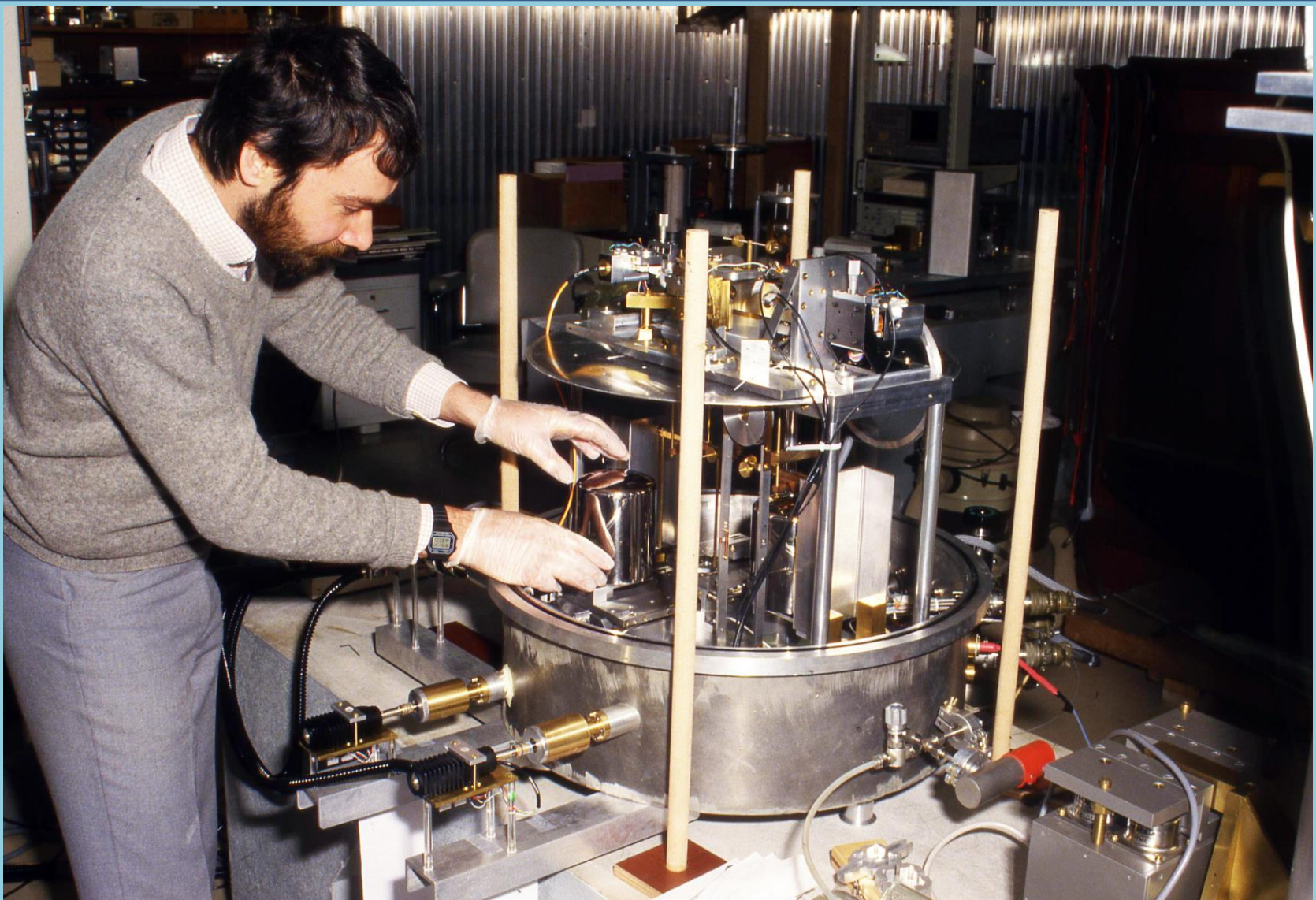

Clive Speake with the flexure-strip balance in the 5<sup>th</sup> force experiment in which we weighed 2 kg objects over a period of 2 months with a st. dev. of 6 nanograms, i.e., a relative st. dev. of 3 parts in  $10^{12}$

## Stress-dependent damping in Cu–Be torsion and flexure suspensions at stresses up to 1.1 GPa

T.J. Quinn<sup>a</sup>, C.C. Speake<sup>b</sup>, R.S. Davis<sup>a</sup>, W. Tew<sup>c</sup>

<sup>a</sup> Bureau International des Poids et Mesures, Sèvres, France

<sup>b</sup> School of Physics and Space Research, University of Birmingham, Birmingham, UK

<sup>c</sup> National Institute of Standards and Technology, Gaithersburg, MD, USA

Received 20 October 1994; revised manuscript received 9 November 1994; accepted for publication 9 November 1994

Communicated by P.R. Holland

### Abstract

Stress-dependent damping in Cu–Be torsion and flexure suspensions has been measured at stresses up to 1.1 GPa, 95% of the yield stress. The modulus defects of Cu–Be increases from  $4.3 \times 10^{-3}$  to only  $6 \times 10^{-6}$  in this range. A much larger additional damping, originating at the clamping interface between the suspension and its support, was identified and eliminated.

### 1. Introduction

In an earlier paper [1] we reported observations of frequency-dependent damping of a long-period pendulum supported on a copper–2% beryllium (Cu–Be) flexure strip in tension. In that study we presented measurements of the inelastic after-effect and logarithmic decrement of free oscillations of the pendulum, which indicate that the modulus defect (the difference between the stressed and unstressed modulus of elasticity) of Cu–Be is independent of frequency over a broad range of frequencies. We showed that the data observed may be modelled by a distribution of dislocation relaxation processes of equal strength, with relaxation times from less than a few seconds to greater than a few thousand seconds and a population varying inversely with the relaxation time. We also noted, as had been previously pointed out [2], that this damping would give rise to a spectrum of perturbing noise torques in a weak force detector whose spectral density would vary as  $1/f$ . Fur-

ther, the microscopic theory we developed predicted that as the stress,  $\sigma$ , approached the yield stress,  $\hat{\sigma}$ , we should observe

$$\frac{\Delta E}{E} \propto \frac{\sigma/\hat{\sigma}}{1-\sigma/\hat{\sigma}}. \quad (1)$$

For precipitation hardened Cu–Be, the yield stress is about 1 GPa, which corresponds to a strain of about 0.6%. Our paper [1] was principally concerned with the frequency dependence of the modulus defect and no systematic study was made of its stress dependence, all measurements being made at about 5% of yield stress. We did report, however, a proportional increase in damping when the flexure was thinned by some 20% to remove surface damage. We took this as an indication that the modulus defect increases with stress in a manner consistent with Eq. (1).

We now report the results of a more systematic study of the stress-dependent damping in the same Cu–Be alloy measured in both flexure and torsion. These new results are not consistent with the predictions of Eq. (1). Accurate measurements of stress-



## 1. Introduction

In an earlier paper [1] we reported observations of frequency-dependent damping of a long-period pendulum supported on a copper-2% beryllium (Cu-Be) flexure strip in tension. In that study we presented measurements of the inelastic after-effect and logarithmic decrement of free oscillations of the pendulum, which indicate that the modulus defect (the difference between the stressed and unstressed modulus of elasticity) of Cu-Be is independent of frequency over a broad range of frequencies. We showed that the data observed may be modelled by a distribution of dislocation relaxation processes of equal strength, with relaxation times from less than a few seconds to greater than a few thousand seconds and a population varying inversely with the relaxation time. We also noted, as had been previously pointed out [2], that this damping would give rise to a spectrum of perturbing noise torques in a weak force detector whose spectral density would vary as  $1/f$ . Fur-

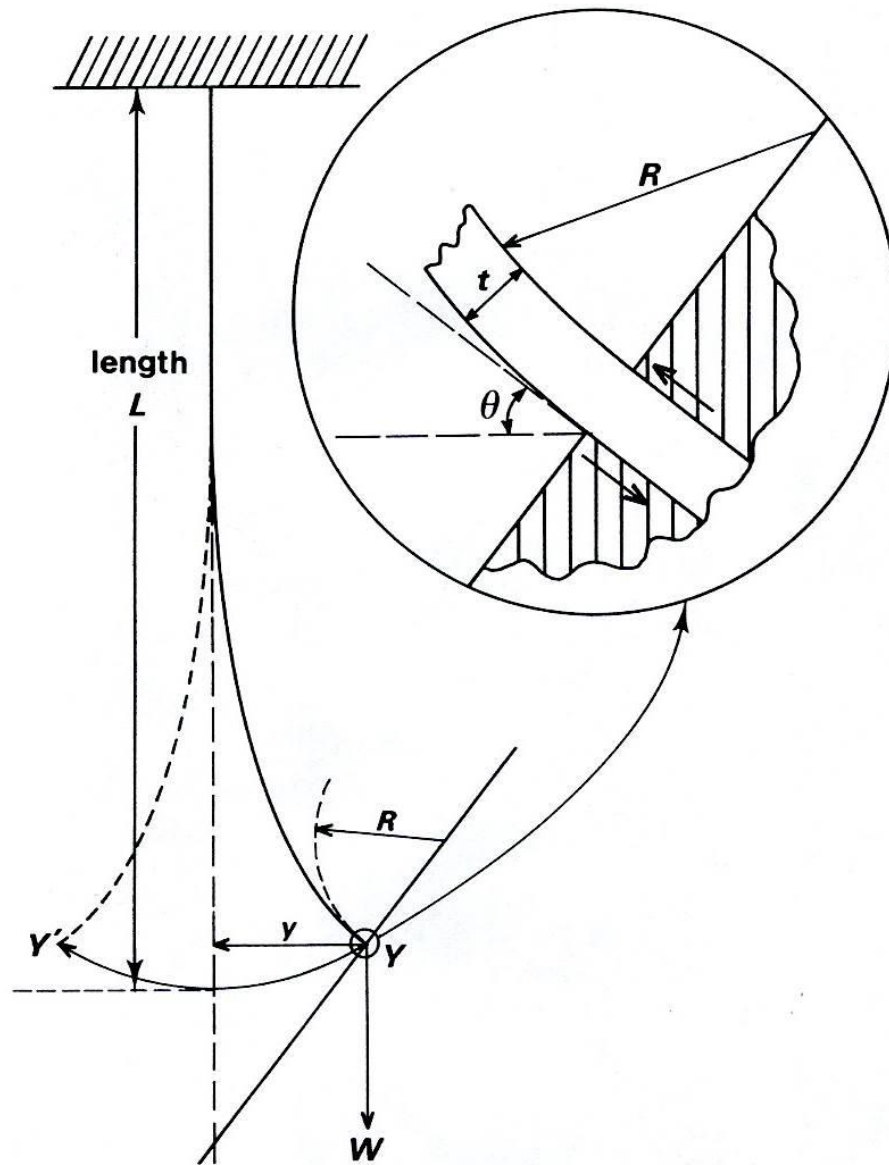

**Fig. 1.** The shape of a flexure strip under a load  $W$  applied at the lower end of the flexure. Inset illustrates the shear stresses acting at the interfaces between the strip and the clamping blocks.

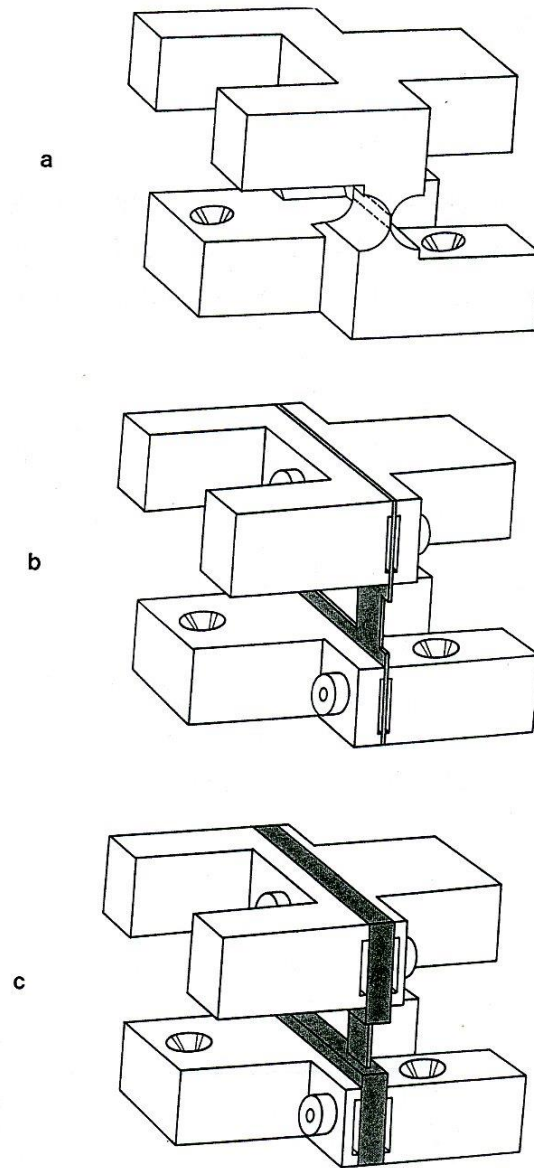

Fig. 3. Cu-Be flexure strip assemblies. (a) Flexure cut from solid block of Cu-Be. (b) Composite flexure made from an  $80\ \mu\text{m}$  Cu-Be sheet clamped between steel blocks. (c) Composite flexure made from  $1.4\ \text{mm}$  thick Cu-Be sheet with a  $90\ \mu\text{m}$  thick flexure cut in it and steel clamping blocks.

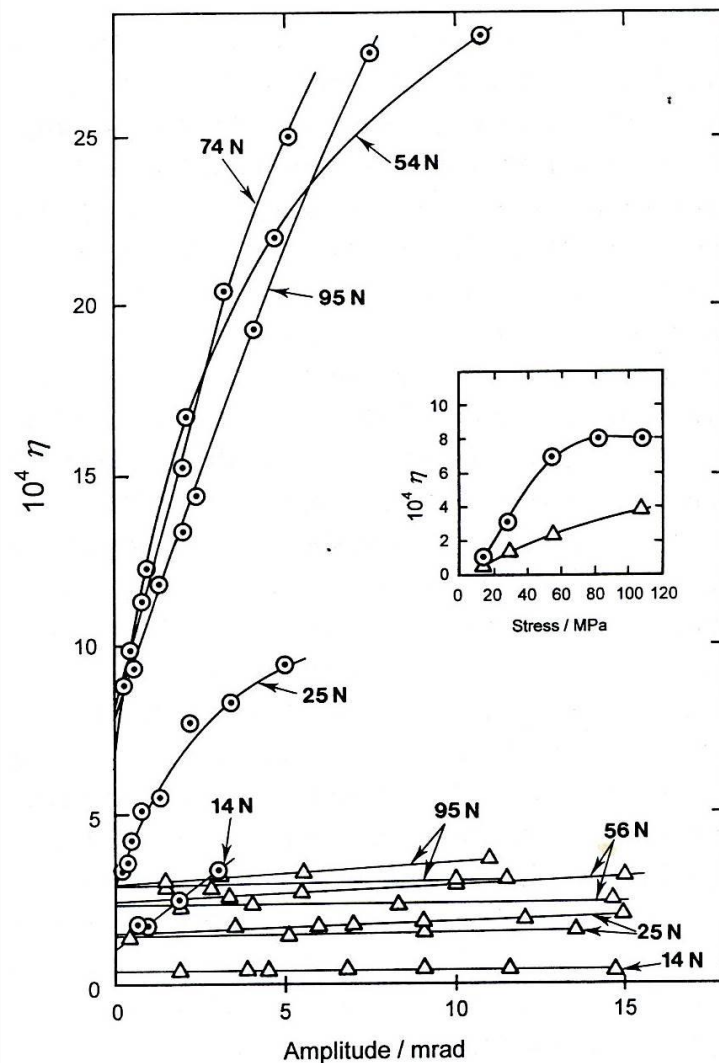

Fig. 5. Measured values of logarithmic decrement,  $\eta$ , as a function of the amplitude of the pendulum oscillation for a range of pendulum loads: flexure made from an 80  $\mu\text{m}$  thick sheet directly clamped between steel blocks (Fig. 3b);  $\Delta$  flexure made from a 1.4 mm thick sheet having an integral 90  $\mu\text{m}$  thick flexure (Fig. 3c). Inset: values of  $\eta$  obtained by extrapolating these curves to zero amplitude plotted as a function of stress.

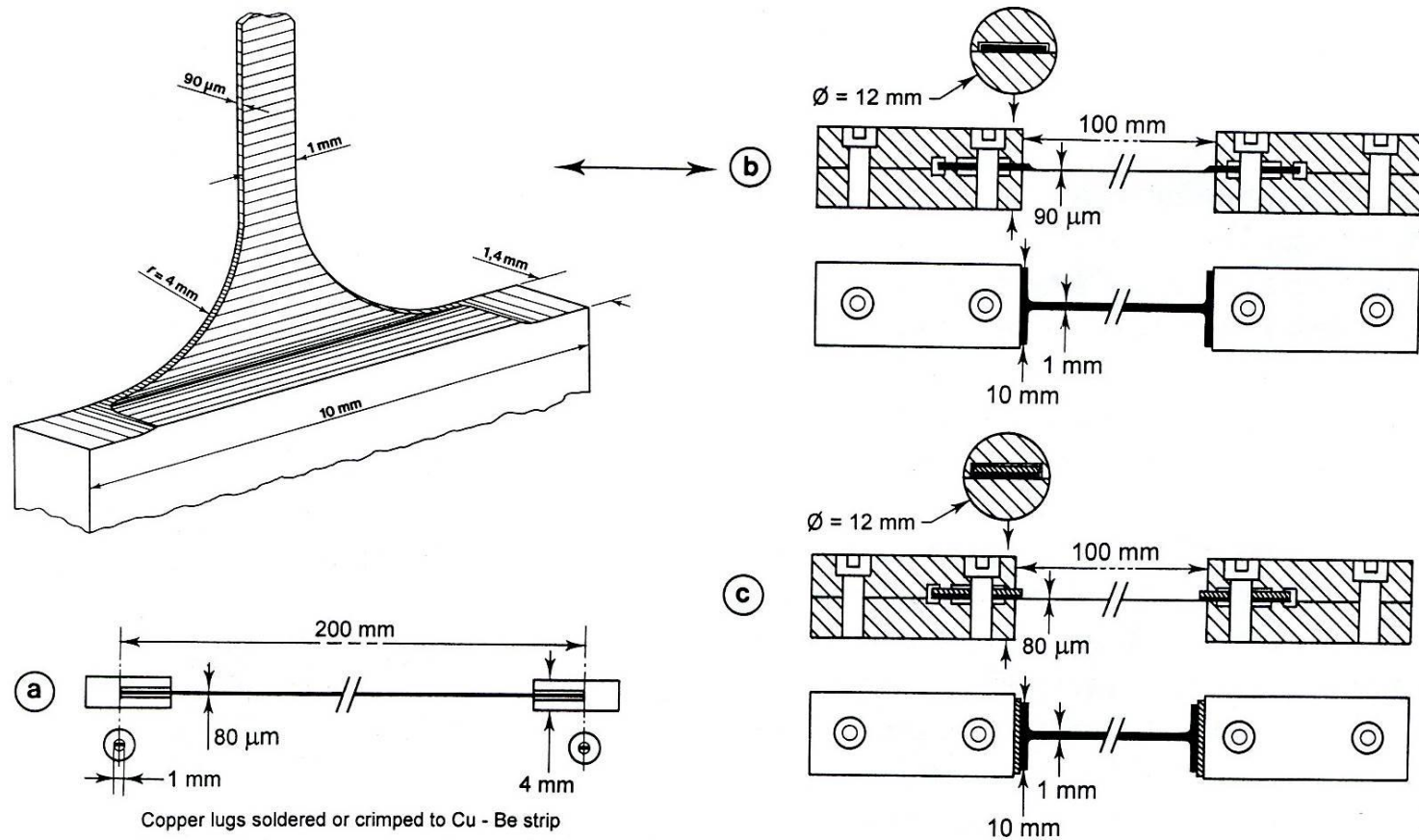

Fig. 4. Cu-Be torsion strip assemblies. (a) 200 mm long strip cut from an 80  $\mu\text{m}$  thick sheet and either soldered or crimped into copper end lugs. (b) 100 mm long strip, 90  $\mu\text{m}$  thick and 1 mm wide cut from a 1.4 mm thick sheet to give integral 10 mm wide end plates for clamping in steel blocks. (c) 100 mm long strip, cut from an 80  $\mu\text{m}$  thick sheet having 10 mm wide ends for clamping between steel blocks.

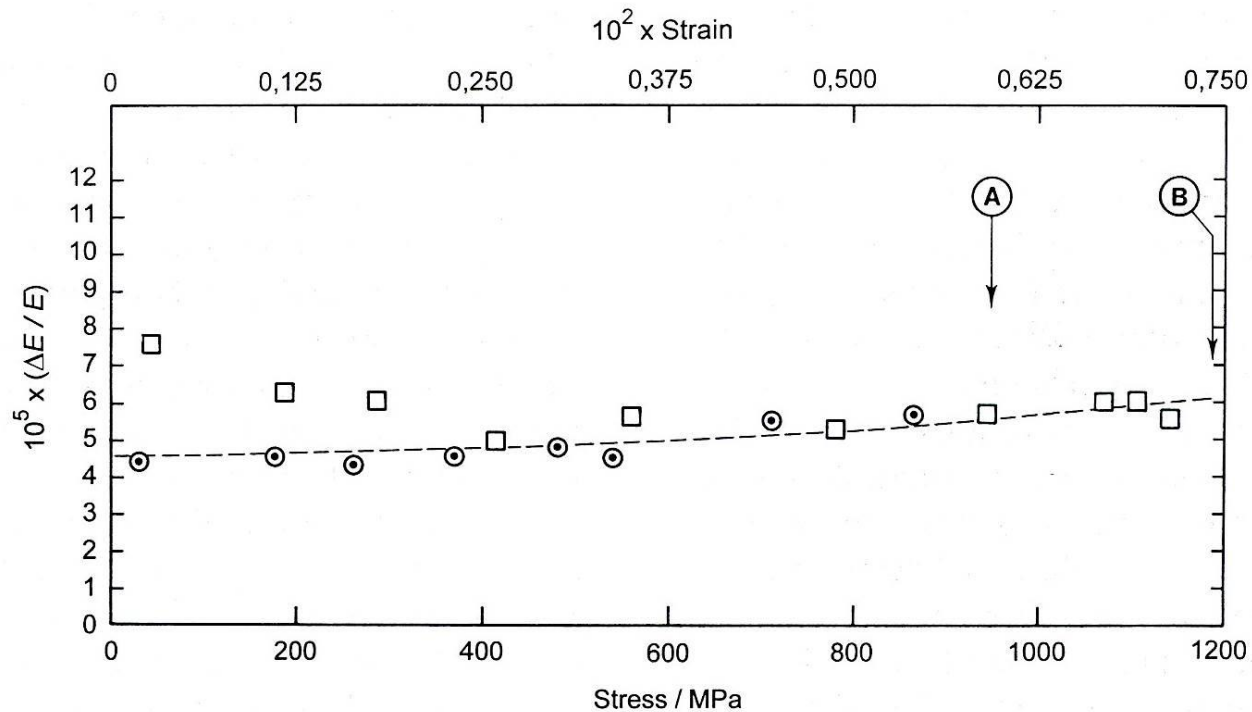
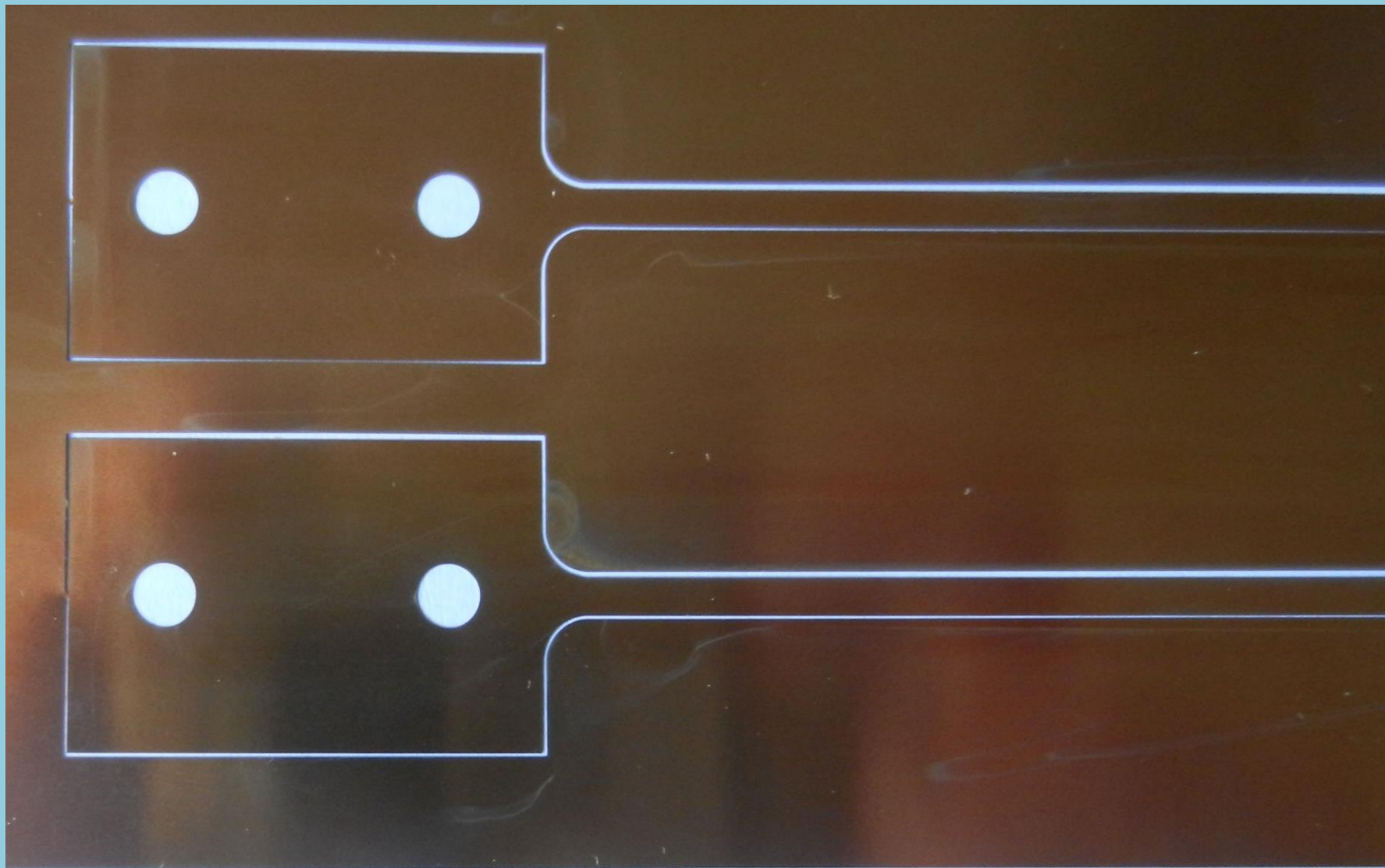

Fig. 6. The modulus defect,  $\Delta E/E$ , for two Cu-Be strips measured as a function of stress up to the breaking points using a torsion pendulum having periods from 28 to 73 s. The first strip (○) was 90  $\mu\text{m}$  thick, 1 mm wide and 100 mm long and cut from a 1.4 mm Cu-Be sheet (see Fig. 4b); it failed as a load of 950 MPa was being applied; the second (□) was 80  $\mu\text{m}$  thick and cut from an 80  $\mu\text{m}$  thick sheet (see Fig. 4a); it failed a few minutes after a load of 1150 MPa had been applied.

Recently, Cagnoli et al. [7] have shown that the  $\omega^{-2}$  dependence of  $\eta$ , which implies a frequency-independent modulus defect, observed in this and in our earlier work, can be explained on the basis of a stick/slip mechanism in the dynamics of dislocation movement. The arguments they use to reach this conclusion invoke the ideas of self-organized criticality. They assume that in the presence of a high stress, the

dislocation network arranges itself at or close to a critical state. A small perturbation stress will unlock a self-adjusting cascade of events over a wide range of length and time scales. Such a sequence of events is not dissimilar to the locking and unlocking of a highly stressed interface such as that where our strips are clamped. It exhibits the same frequency independence as the dislocation damping.





The Cu-Be torsion strip used in the BIPM G measurements:  
30 $\mu$ m thick  
2.5 mm wide  
160 mm long  
with ends expanded to a width of 20 mm.

With a load of 6 kg and a torsion balance with a moment of inertia of about 0.07 kg m<sup>2</sup>, this gave a period of 120 s and a  $Q > 10^5$

The effects of anelasticity in the material and stick/slip at the mounting were at the level of a few ppm.



$$c = bt^3 F/3L$$

$$c = I \omega^2 = I 4\pi^2/T^2 \approx 16Mr^2 \pi^2/T^2$$

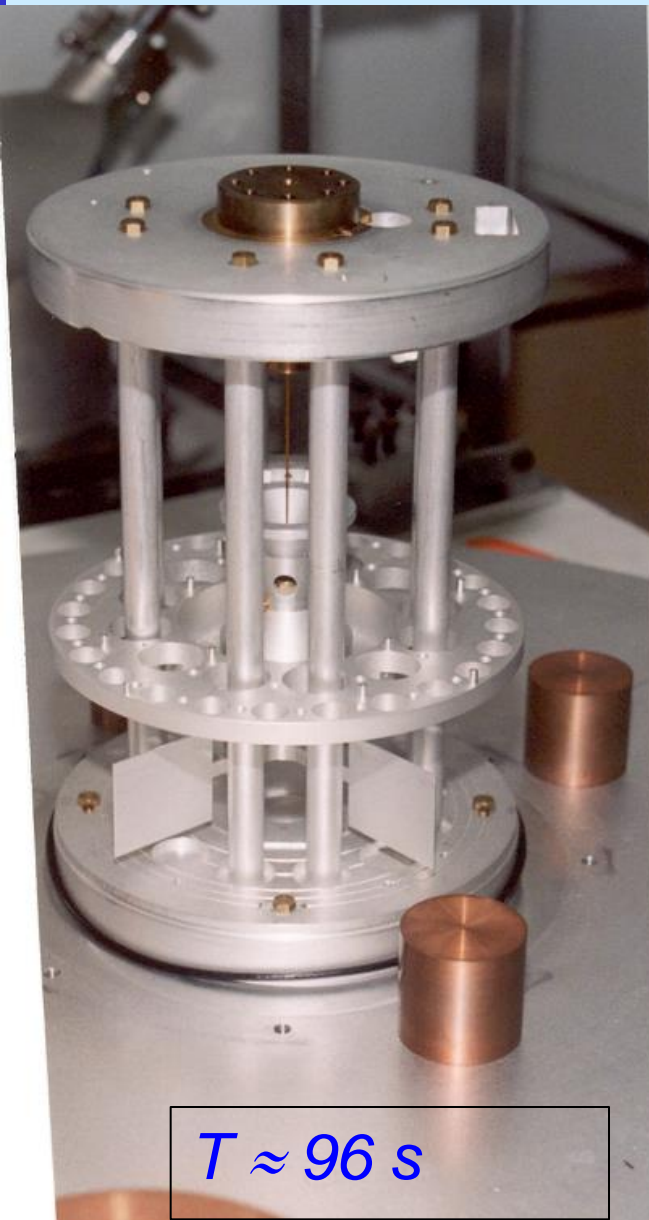

$T \approx 96 \text{ s}$

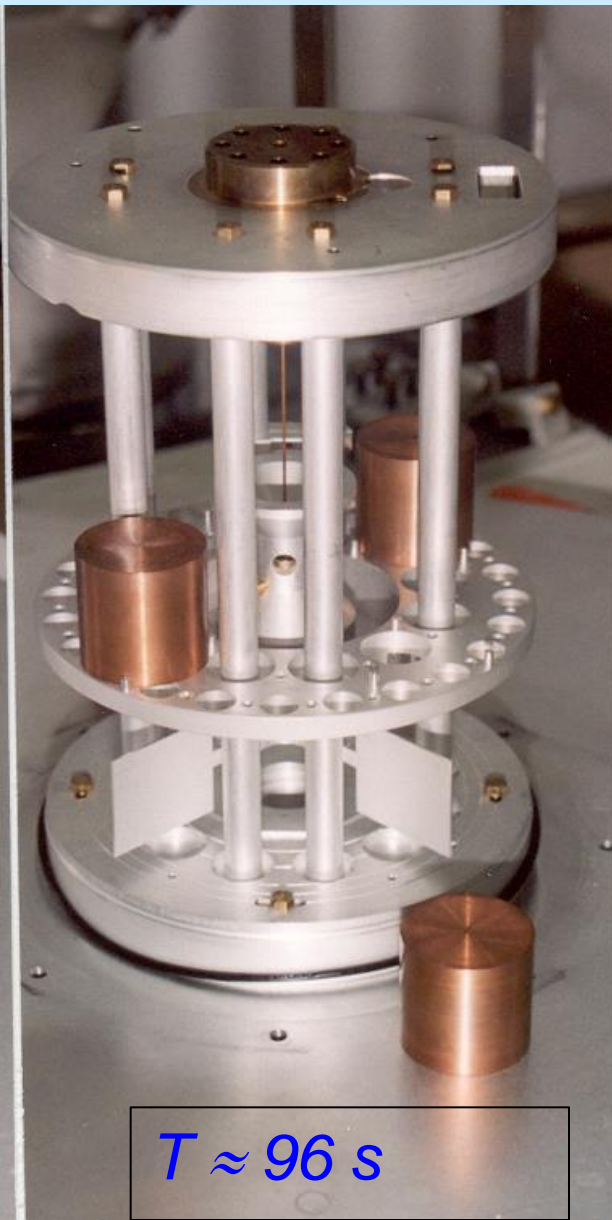

$T \approx 96 \text{ s}$

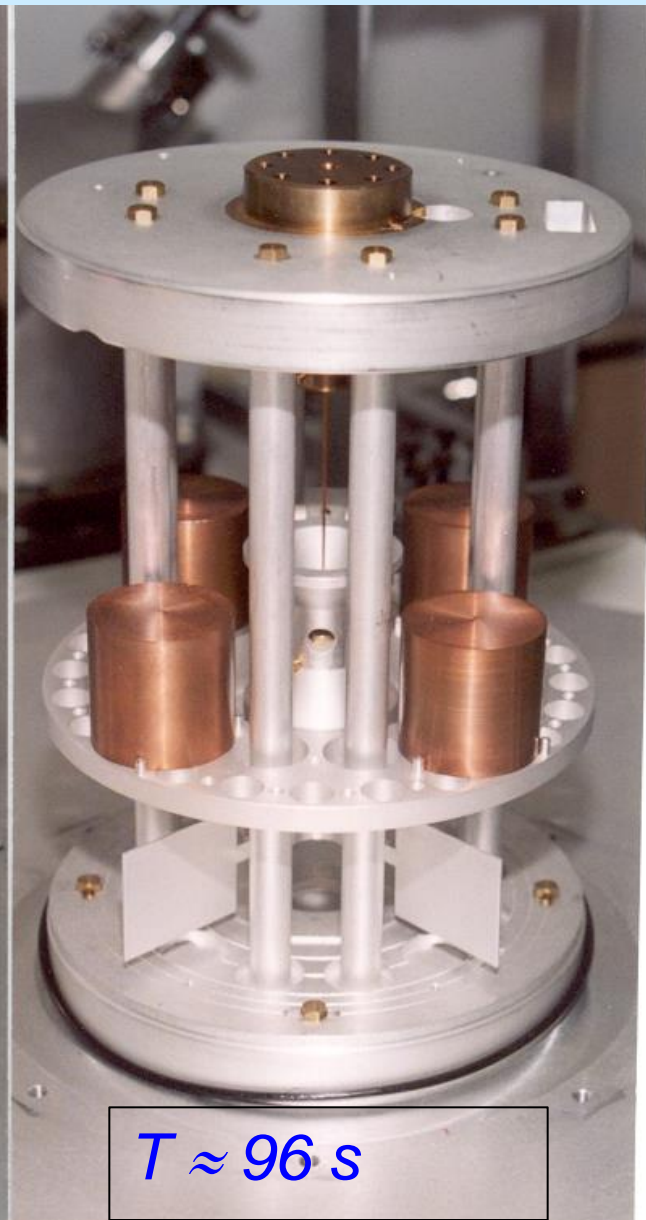

$T \approx 96 \text{ s}$

$$c = bt^3 F/3L + Mgb^2/12L, \text{ where } bt^3 F/3L \ll Mgb^2/12L \text{ (97\%)}$$

$$c = I \omega^2 = I 4\pi^2/T^2 \approx 16Mr^2 \pi^2/T^2 \approx Mgb^2/12L$$

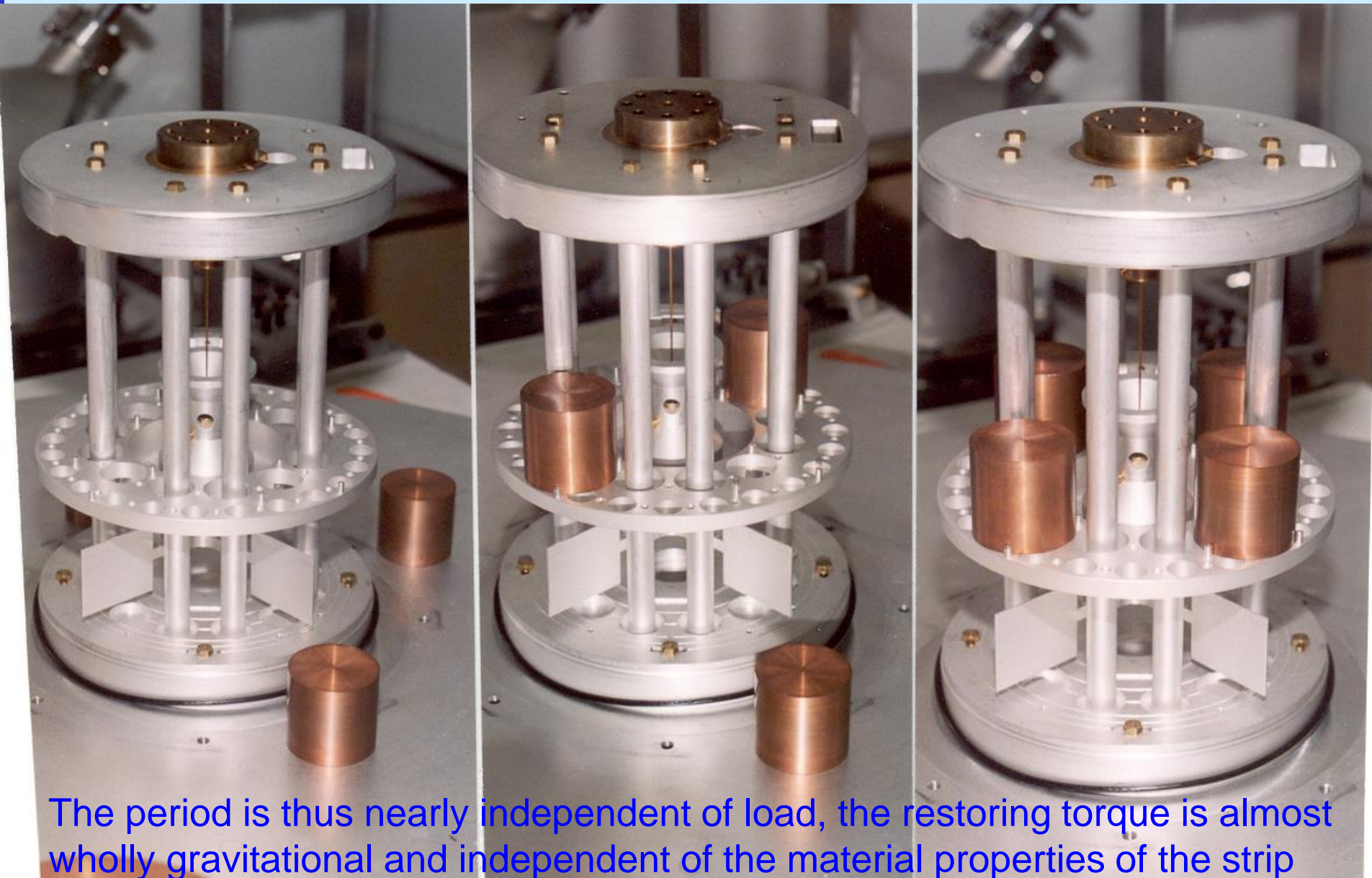

The wide heavily loaded torsion strip designed in this way is thus free from the effects of stick/slip at the points of attachment and free from effects of anelasticity in the material because the restoring torque is about 97% gravitational and thus lossless. Measured  $Q_s$  were greater than  $10^5$  with a period of 120 s

Now back to the value of  $G$ !

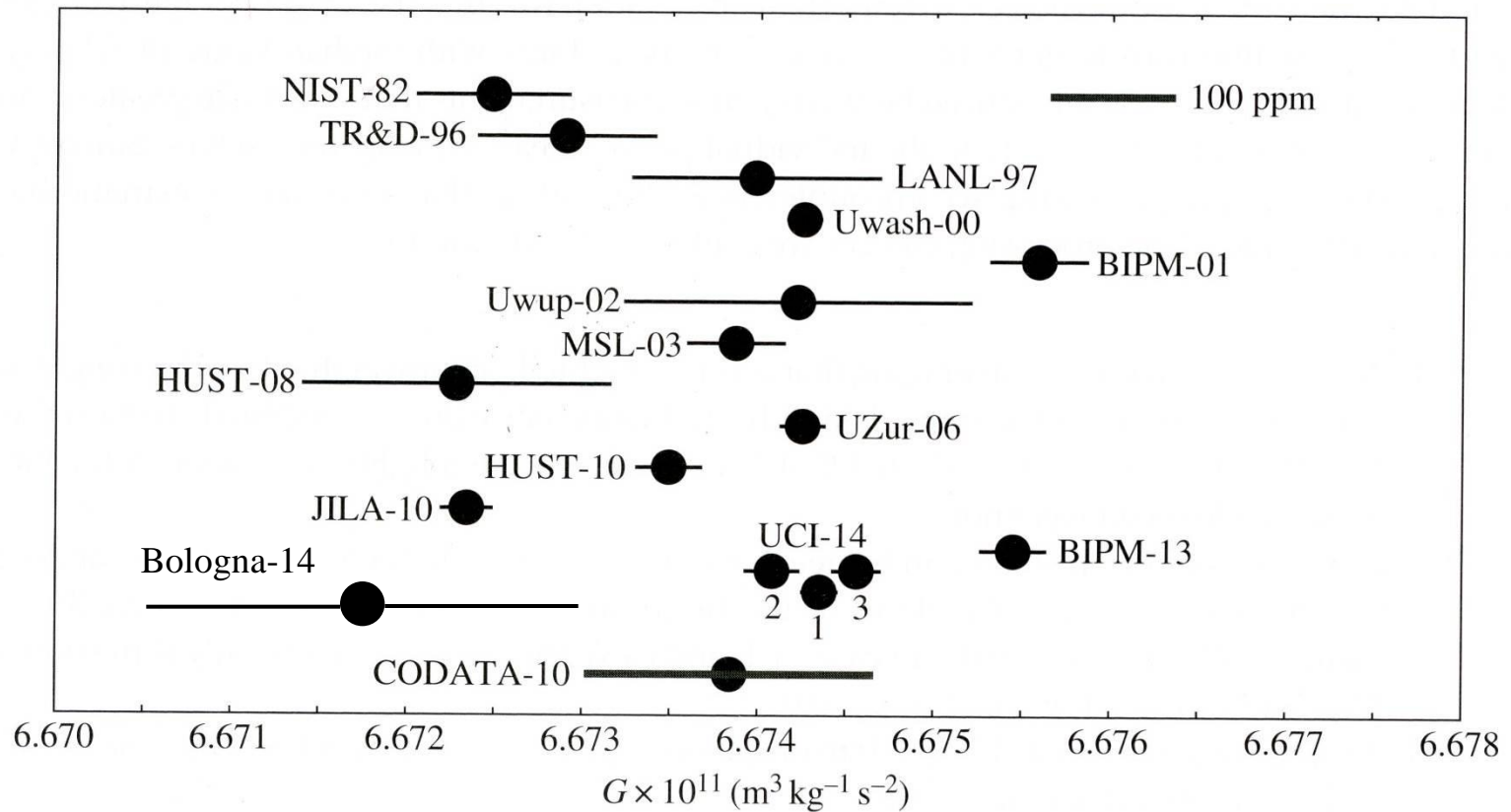

**Figure 6.**  $G$  measurements reported in recent years. The designations and  $G$ -values correspond to those recorded in the 2010 CODATA report [8] with the exception of BIPM-13 [9] and the results reported in this paper, denoted here as UCI-14. The fibres used in obtaining the three UCI values are indicated below their position in the plot. Fibre 1 was as-drawn CuBe, fibre 2 was heat-treated CuBe, and fibre 3 was as-drawn Al5056. (Online version in colour.)

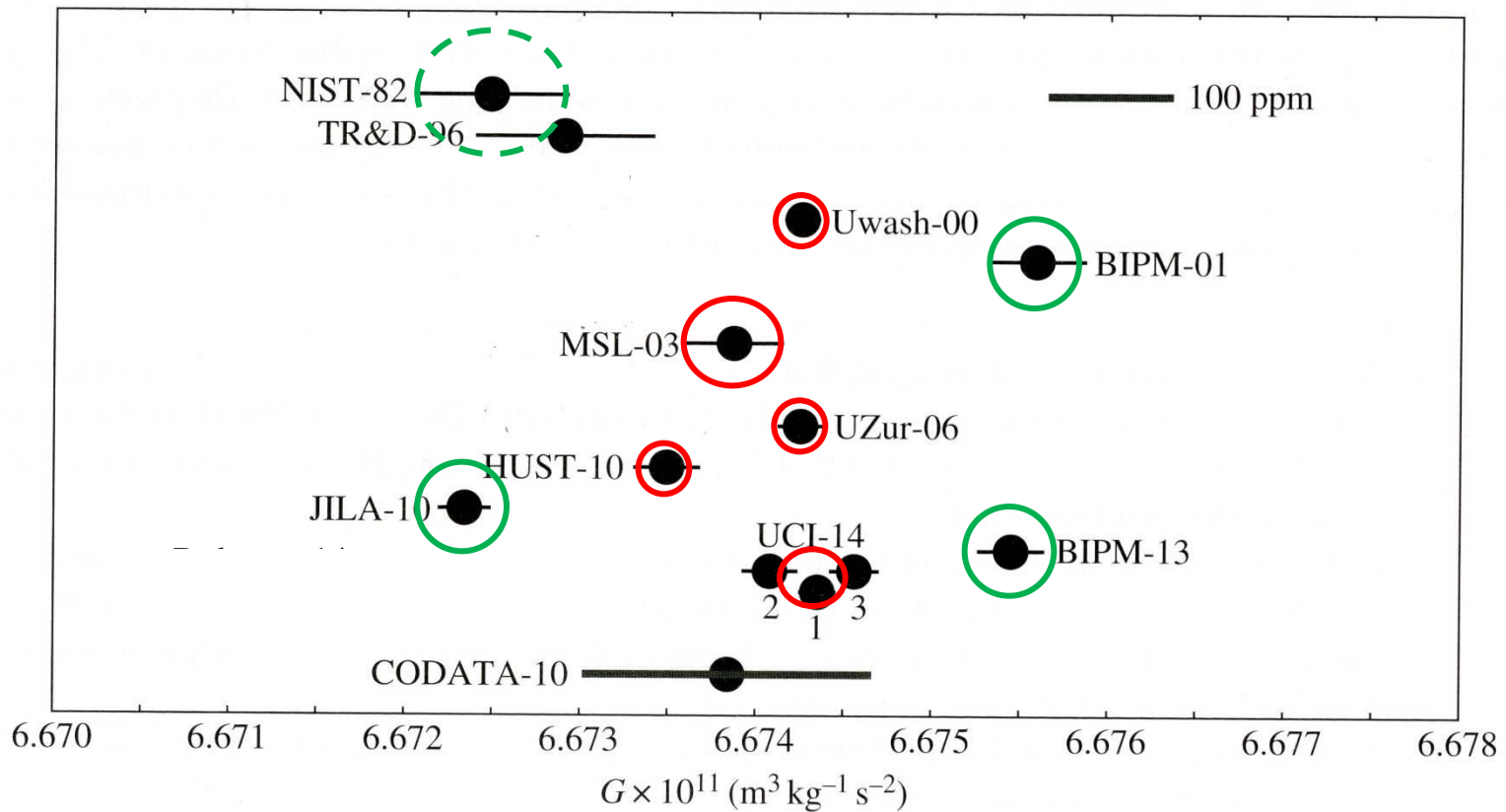

**Figure 6.**  $G$  measurements reported in recent years. The designations and  $G$ -values correspond to those recorded in the 2010 CODATA report [8] with the exception of BIPM-13 [9] and the results reported in this paper, denoted here as UCI-14. The fibres used in obtaining the three UCI values are indicated below their position in the plot. Fibre 1 was as-drawn CuBe, fibre 2 was heat-treated CuBe, and fibre 3 was as-drawn Al5056. (Online version in colour.)

### Another view of the ensemble of current results

The red circles indicate the set of results from which one could deduce a value for  $G$  with an uncertainty below 30 ppm based on three very different methods. Under this scenario the outliers are the BIPM and JILA results. Thus these are the ones that need to be checked.





