

Testing the Electrical Conductivity of Solid Electrolytes

By: Jake Gurowitz
Gaithersburg High School





Introduction

- This is a group project involving
 - 3 SHIP students
 - 4 mentors
 - A SURF intern
- The overall project goal is:
 - to develop an efficient solid-state electrolyte
 - test the impedance and conductivity of this electrolyte
- My contribution to the project
 - Design a test cell adapter

Materials other than Lithium

- Lithium is less abundant and extremely dangerous when used as an electrolyte.
- There are other types materials to be used as solid electrolytes. Such as these salts:
 - Sodium
 - Calcium
- These materials are safer, cheaper and abundant.



Demonstration of Sample Well

- To the right is the sample stick, and the cryostat where the cell will be going inside of.
- The cell needs to fit inside the well while attached to the end of the sample stick.

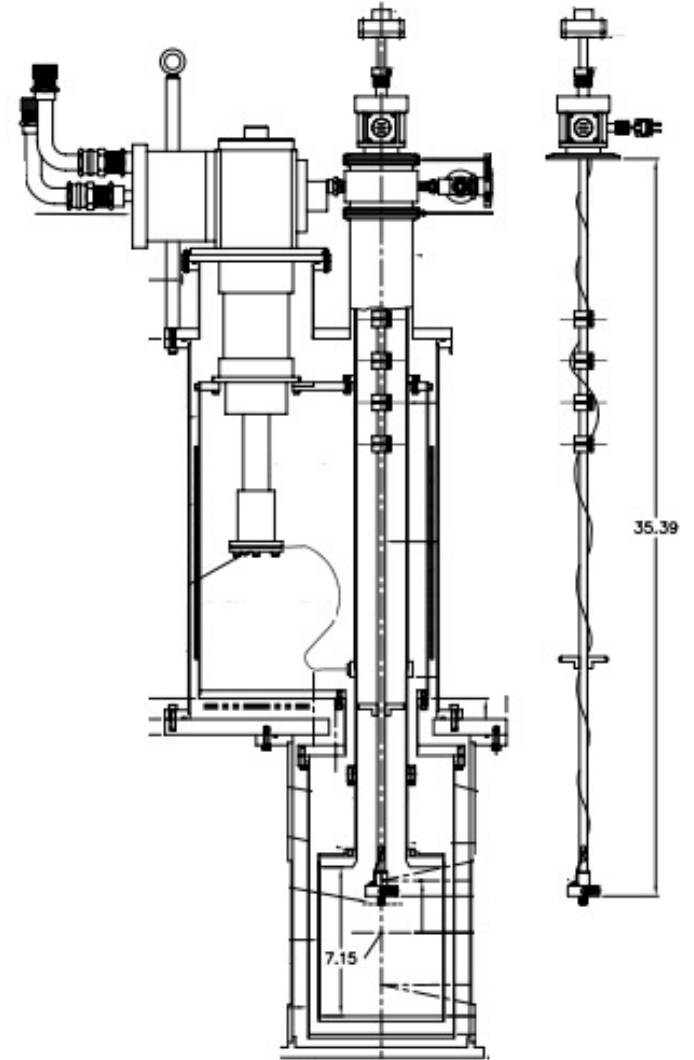

Modification of commercially available impedance cell

- The cell needs to fit down a sample well of a cryostat.
- We needed to modify the cell in order for it to fit down the well.

Before Cuts:

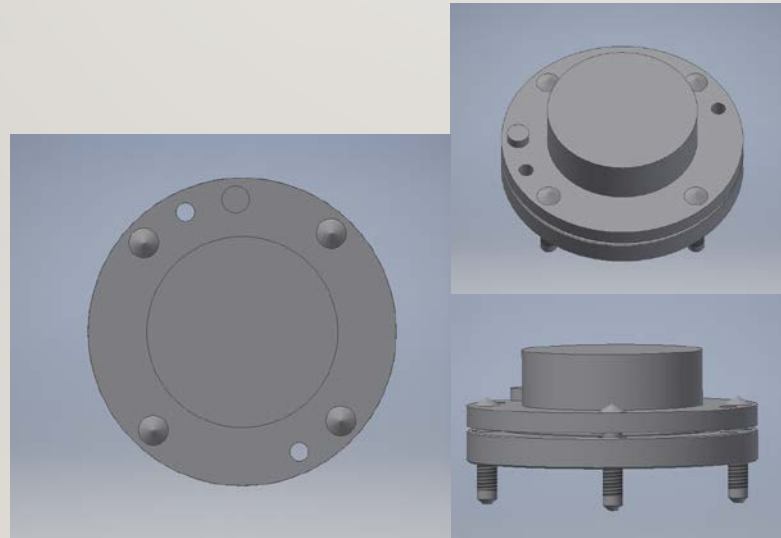

After Cuts:



Designing Thermal Adapter for Electrolyte Cell

- Thermal adapter needed to connect sample stick to cell.
- Design and construct an adapter that will conduct heat throughout the cell without conducting electricity.

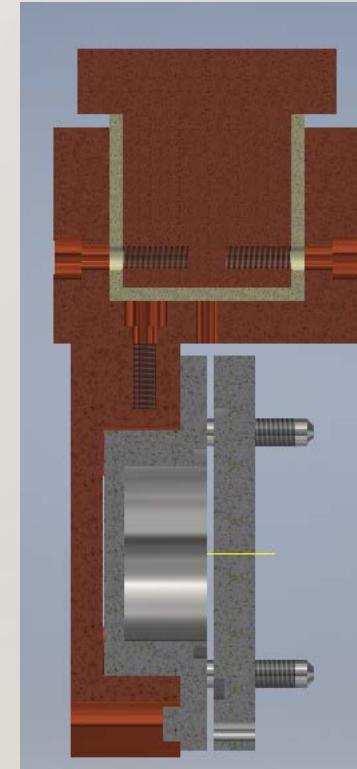

The Thermal Adapter

1. Must conduct heat throughout the cell
2. Must not conduct electricity through cell
3. Thermal conductivity:
 - a) $\text{Al}_2\text{O}_3 \sim 40.0 \text{ W/m-K}$
 - b) SS $\sim 16.2 \text{ W/m-K}$
 - c) Copper $\sim 400 \text{ W/m-K}$
4. The adapter will use both, copper and Alumina. Copper for the inner and outer layers, while Alumina for the middle layer. This will insulate both sides of the electrolyte pellet from the sample stick.



Modifying the Alumina Piece

- Used a diamond saw to cut an alumina crucible to size

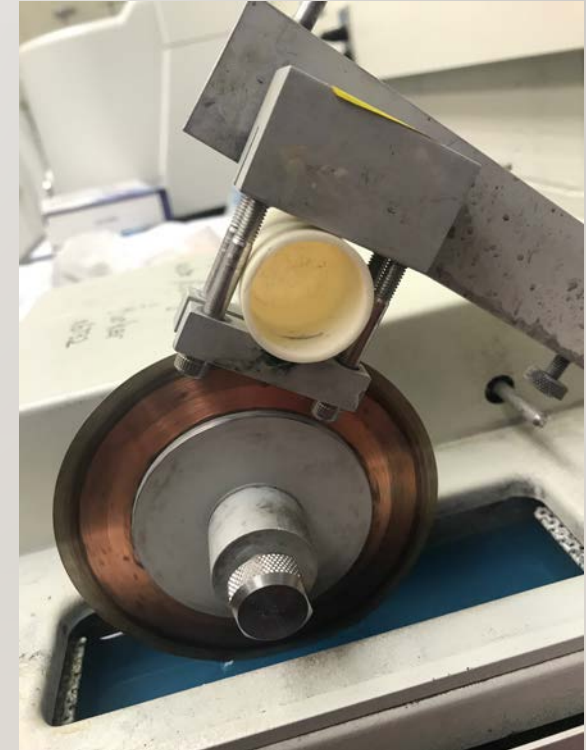

Assembly of the Thermal Adapter

- The assembly for the Thermal Adapter includes:

1. The inner copper
2. The Alumina
3. The outer copper
4. The thermal contact interface (copper)

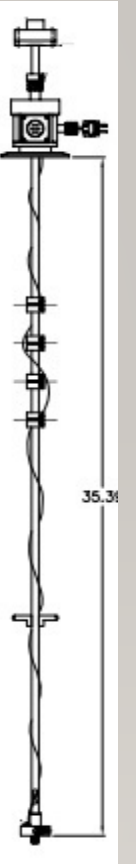
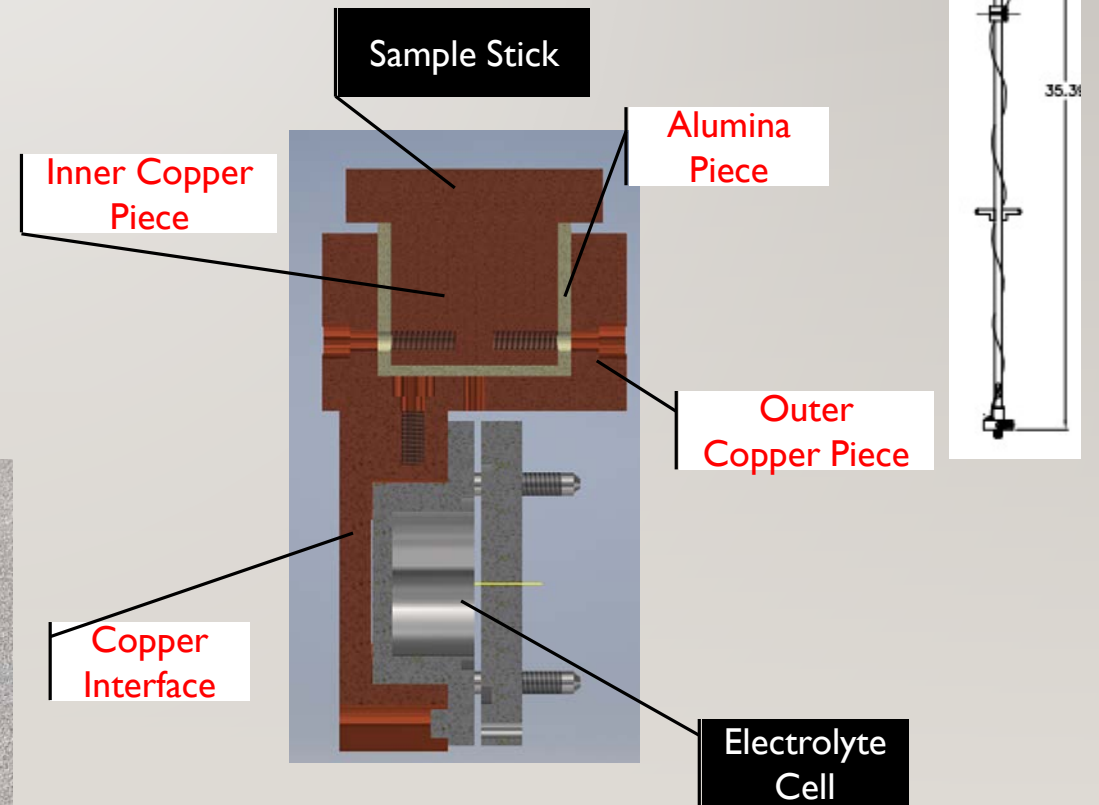

Results

- Here are the results of testing one of the samples. As the temperature increases you can see the conductivity also rises.

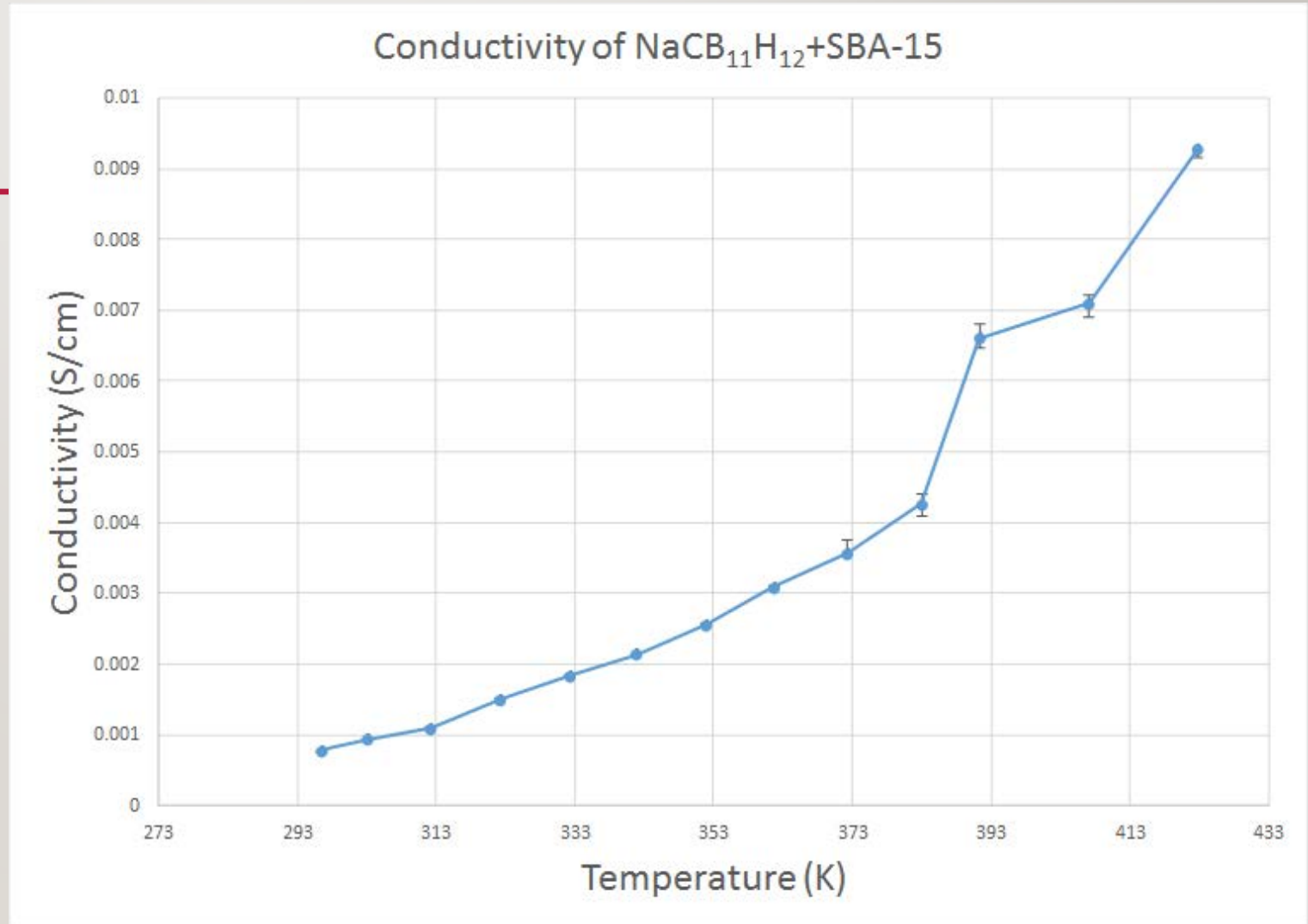



Next Steps

- Measure the sample with the neutron beam.
- The nucleus' cross-section of an atom will determine the probability a neutron can hit it.
- Stainless steel has a bad cross-section, therefore the cell needs to be redesigned.

Aluminum Total Neutron Cross
Section: 0.232 barns

VS.

Iron Total Neutron Cross
Section: 2.56 barns



A Big Thanks!!



Mentors:

- Terrence Udovic
- Wan Si Tang
- Juscelino Leao
- Mirjana Dimitrievska
- Paul Neves (SURF Intern)
- Patrick Connelly

Co-Interns:

- Malgorzata Psurek
- Erin Huang

SHIP Directors:

- Dan Neumann
- Yamali Hernandez
- Julie Borchers

NIST Organizations and Affiliations:

- NIST Summer High School Intern Program (SHIP)
- NIST Center for Neutron Research (NCNR)
- National Institute of Standards and Technology (NIST)
- Center for High Resolution Neutron Scattering (CHRNS)