

Understanding Meaningful Use with a Focus on Testing the HL7 V2 Messaging Standards
Robert Snelick, National Institute of Standards and Technology (NIST)
Sheryl Taylor, Booz-Allen Hamilton (BAH)

Use of electronic health records (EHRs), especially systems with clinical decision support capabilities, has been shown to enable quality improvement in healthcare as well as to help reduce the cost of that care when used regularly in the practice of medicine. These facts contributed to the impetus for Congress to enact the Health Information Technology for Economic and Clinical Health (HITECH) Act, a component of the American Recovery and Reinvestment Act (ARRA) of 2009, and which provides funding for incentive payments to physicians and hospitals that adopt health information technology (HIT). Initially focusing on adoption of EHRs, approximately \$17 billion in the Center of Medicare and Medicaid Services (CMS) incentive payments are available through CMS's HITECH-based EHR Meaningful Use (MU) Program, to be paid to providers that attest to or demonstrate "meaningful use" of "certified" EHR technology (CEHRT). In response to this mandate for use of CEHRT, the Office of the National Coordinator (ONC) established a certification program and published EHR certification criteria. The National Institute of Standards and Technology (NIST) developed test procedures and conformance test tools based on the ONC's EHR certification criteria. This article briefly explains the history and purpose of the ONC certification program, and provides insight into the test procedures and testing process for the Health Level 7 (HL7) Version 2 (V2) messaging standards. It also presents an overview of the test tools that are used by testing laboratories to ensure that vendors' EHR technologies meet the requirements of CEHRT.

Adoption and use of CEHRT are required for eligible professionals (EPs) and eligible hospitals (EHs) to become "meaningful users" and to receive payments from the CMS EHR Incentive Program. On January 3, 2011, the ONC released the Final Rule to establish a permanent program for certification of Health IT. This "ONC HIT Certification Program" was launched on October 4, 2012, replacing the previous temporary program.

As shown in Figure 1, the ONC HIT Certification Program correlates directly to the CMS MU Final Rule as well as the ONC Health IT Standards, Implementation Specifications and Certification Criteria Final Rule (ONC Final Rule). CMS MU requirements are behavioral in scope, specifying how the EPs and EHs must use the CEHRT in order to receive the incentive payments. Based on the MU requirements, ONC defines the technical criteria CEHRT must meet and manages the development and implementation of certification testing procedures.

Thus far, CMS and ONC have published two sets of requirements for MU and for EHR certification known as Stage 1 or 2011 Edition and Stage 2 or 2014 Edition. Included in the ONC criteria are interoperability standards, such as HL7 V2 implementation guides and vocabulary standards. ONC CEHRT requirements do not represent a comprehensive list of all EHR capabilities that a physician's office or a hospital might want or need, but they are a baseline of capabilities that CEHRT must support. Additional MU Stages are planned, and the requirements are anticipated to become more challenging, demanding more capabilities.

Figure 1: Correlation of CMS MU Final Rule, ONC Final Rule, and ONC HIT Certification Program

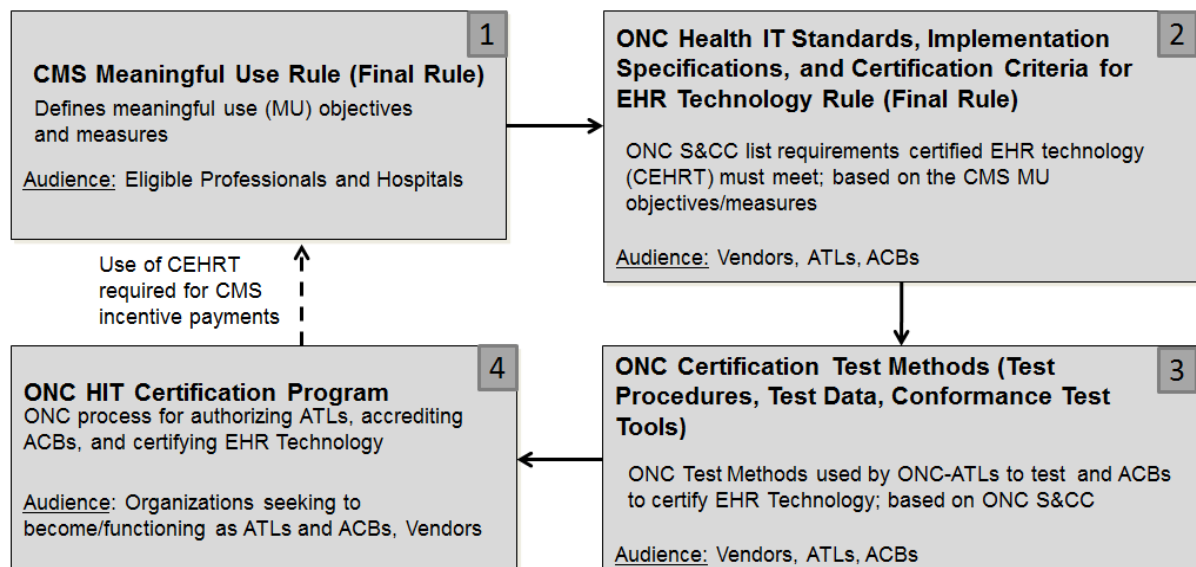

The ONC HIT Certification Program manages the testing and certification of EHR technologies by Accredited Testing Laboratories (ATLS) and Authorized Certification Bodies (ACBs). “Testing” is the process used by an ATLS to determine the degree to which the EHR technology meets the specific certification criteria. “Certification” is the assessment and affirmation made by an ACB once it has analyzed the quantitative results produced by the testing and determined that the EHR technology has met all of the applicable certification criteria. ONC reviews the product certification provided by the ACB, and then posts it to the online Certified HIT Product List (CHPL), thereby designating the product as a CEHRT.

In order to verify that EHR technologies meet the ONC certification criteria, a test method was developed for use by the ATLS. The ONC test method is composed of test procedures, test data, and (where applicable) conformance test tools. Test procedure documents provide a standard structure for the content related to the certification testing steps; the test data work in conjunction with the test procedures to further indicate the intent of the ONC policies behind the certification criteria; and the conformance test tools work with the test procedures and test data to enable *automated* and *semi-automated* validation of the EHR technologies’ conformance to the certification criteria and the named interoperability standards.

Conformance Test Tools

The 2014 Edition/Stage 2 ONC EHR certification standards and criteria specify four HL7 V2 implementation guides that apply to five certification criteria; (1) transmission to immunization registries, (2) syndromic surveillance to public health agencies, (3) transmission of reportable lab results to public health agencies, (4) transmission of electronic lab results to ambulatory providers, and (5) incorporation of lab tests and results. NIST has developed the test procedure and conformance test tool for each of these criteria. The links to these test tools are provided along with standards they target:

- Immunization: <http://hl7v2-iz-testing.nist.gov/mu-immunization/>
 - HL7 2.5.1 Implementation Guide for Immunization Messaging, Release 1.4
 - HL7 Standard Code Set CVX -- Vaccines Administered
- Syndromic Surveillance: <http://hl7v2-ss-testing.nist.gov/mu-syndromic/>
 - HL7 2.5.1 PHIN Messaging Guide for Syndromic Surveillance
- Reportable Laboratory Results (ELR): <http://hl7v2-elr-testing.nist.gov/mu-elr/>
 - HL7 Version 2.5.1 Electronic Laboratory Reporting to Public Health, Release 1
 - SNOMED CT® and Logical Observation Identifiers Names and Codes (LOINC®)
- Laboratory Results Interface (LRI): <http://hl7v2-lab-testing.nist.gov/mu-lab/>
 - HL7 Version 2.5.1 Implementation Guide: S&I Framework Lab Results Interface
 - Logical Observation Identifiers Names and Codes (LOINC®)
 - Note the LRI test tool covers both the transmission of laboratory results criteria and the incorporation of laboratory results criteria

Central to certification is conformance testing of the technical requirements and capabilities of the EHR technology. Testing is facilitated with the use of specific test cases and data. Through consultation and collaboration with subject matter experts from the ONC Standards and Interoperability (S&I) Framework, the Centers for Disease Control (CDC), the Association of Public Health Laboratories (APHL), and the International Society for Disease Surveillance (ISDS), NIST developed test cases that targeted the most important use cases and capabilities specified in the referenced standards.

The test data is provided to assist the Tester in verifying that the vendors' EHR technologies are capable of supporting the required functions; verifying the ability to support the specific test data content is a secondary aspect to testing. Testing and verification related to specific content usually is more appropriate for local installations of the EHR technologies; however, for certain aspects of a certification test case, examining exact content is necessary to verify that a capability exists in the EHR technology. An added benefit of providing realistic test data for common use cases is that it reinforces the expected interpretation and use of the referenced standards.

Testing the EHR for Transmitting a Message

When testing the ability to transmit HL7 V2 messages, the focus of the conformance testing strictly centers on validating the message produced by the EHR system (the sender). The System Under test (SUT), the EHR, is treated as a "black box"—how the message is created or transformed is not in scope. If we consider a Laboratory Information System (LIS) or Laboratory module as part of the EHR (hereafter lab component), testing is not concerned with the detailed architecture of the lab component, but rather what it produces (a message) based on a given set of inputs (i.e., the test case). The "black box" can be a self-contained lab component or be composed of multiple modules with a data flow between them, for example, a lab component and an integration engine; however, the "black box" must contain a lab component, and test case data must be entered into and originate from the lab component.

Figure 2: Context-free Validation Test Flow

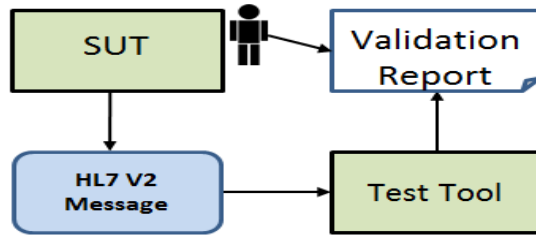

The NIST HL7 V2 conformance test tools for validating sending systems have two operational modes:

- Context-free
- Context-based

The context-free mode validates any message created by the SUT. It is not dependent on any use case, test case, or specific test data content. Figure 2 illustrates the context-free test flow.

Figure 3: Context-based Validation Test Flow

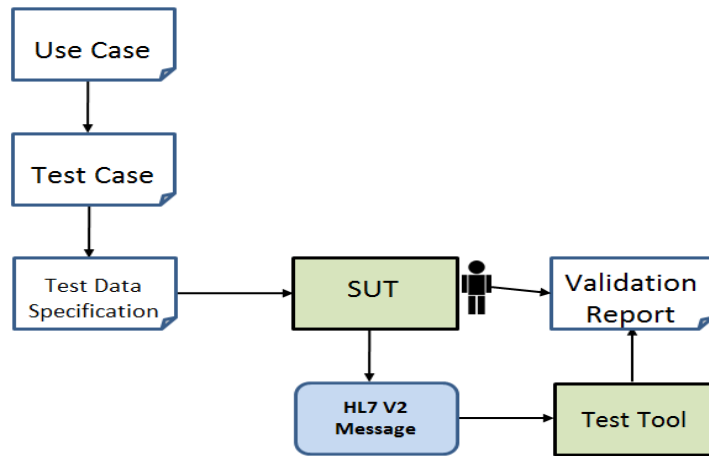

The context-based mode validates messages that are associated with a given use case and test case that includes specific test data that are to be entered into the SUT. The SUT creates a message that corresponds to the test data provided in the test case. Testing assesses the technical requirements and content-specific requirements specified in the test case. Context-based validation expands the test space, enabling more comprehensive testing (e.g., conformance usage constructs such as conditional elements and required, but may be empty elements). Figure 3 shows the context-based test flow.

Although the NIST conformance test tools support both modes of validation, MU EHR certification testing is context-based. However, the context-free validation functionality provided in the test tool can be used to assist certification testing in certain circumstances and provides a useful tool for local installation testing.

Testing the EHR for Incorporation of a Message

Testing the incorporation of laboratory results presents a set of challenges, since there is no output artifact that can be assessed directly. For this criterion the EHR, as the receiving system, is being examined for the *incorporation* of laboratory results and seven display requirements (adopted from CLIA, the Clinical Laboratory Improvement Amendments which are regulatory US standards for clinical laboratory testing). The MU criterion specifies the Laboratory Results Interface (LRI) implementation guide for import of the laboratory results. Conformance testing employs the use of a juror document (inspection check list) and a human inspector. The content of the juror document is derived from the test case and test message. Figure 4 illustrates the test flow of the NIST conformance test tool for the incorporation of laboratory results test procedure.

Figure 4: Test Flow for Testing EHR Receiving Transmission of Lab Results

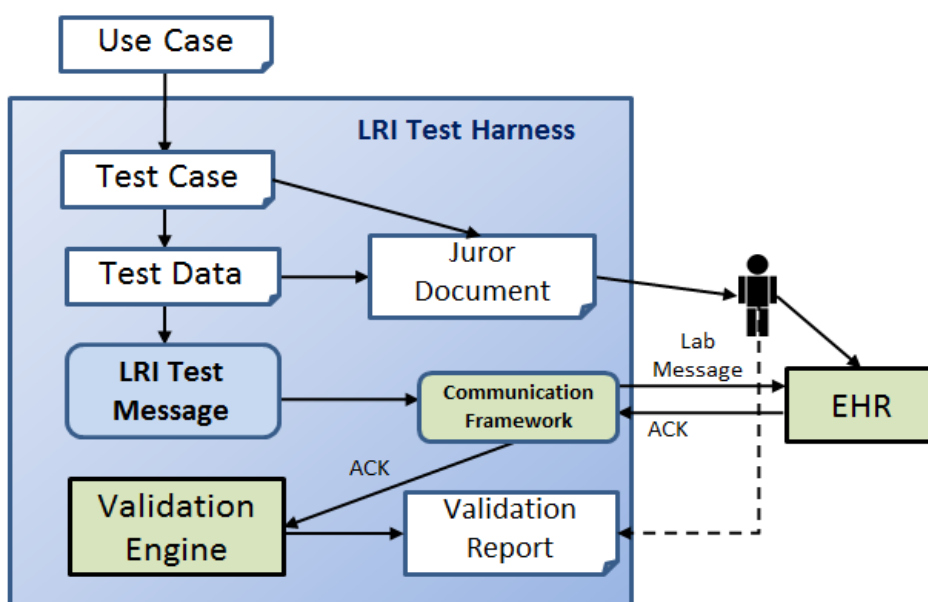

The test tool provides a test harness that interacts with the EHR system, simulating the functionality of an LIS. Test cases are developed for the various use cases described in the LRI implementation guide, and for each test case its respective test data are created. Based on the test case and test data, a test message and juror document is automatically generated by the test tool. The test message is sent to the EHR for incorporation. The ATL Tester uses the juror document to examine the EHR system. The juror document is the test case-specific checklist the Tester uses to document the presence or absence of the data in the EHR for data elements transmitted to the EHR from the LRI Test Harness. The data elements are categorized by how they are verified. For example, some elements are required to be displayed to the clinical user on the EHR screen and stored, while other data elements are required to be stored or derivable. Not all data elements are subject to *incorporation* testing since they are not relevant to the incorporation of laboratory results (e.g., message processing elements).

Certification Testing: What does it mean?

Certification of EHR technology is a critical step towards achieving interoperability for exchanging healthcare information, but it is not the end-all. ONC certification testing for meaningful use focuses on

assessing the capabilities of the EHR product for a given set of requirements. It is not directed at site-specific installations. Purchasing a certified EHR system provides a degree of certainty that the buyer has obtained a product that meets a level of capabilities established by the ONC. End users of certified EHR products will need to configure their products according to their local requirements. Although the ONC HIT Certification Program by design does not extend to installation bases, it provides the foundation and a shorter pathway to achieving site-specific interoperability. Incremental progress in terms of the EHR capabilities and interoperability is the intent as advancement is made through the MU stages.

It is also important to recognize that the ONC certification program targets the EHR technologies and not the systems that interact with them. For example, the transmission to immunization registries certification criterion and associated tests assesses whether the EHR product can create HL7 V2 messages in accordance with the requirements given in the referenced standard. It does not, however, place any requirements on the receiving system, in this case the immunization information systems (IIS) used by the registries. In order to achieve interoperability the receiving systems must implement the corresponding requirements. The Meaningful Use program envisions that these systems will, over time, acquire such capabilities due to market forces and the benefits gained (e.g., the public health agencies will want to take advantage of the standardized interfaces).

One of NIST's roles in developing the test tools is to strictly interpret the requirements as written in the standards and the ONC EHR certification criteria, and then develop test cases to test to those requirements accordingly. This process has led to the discovery of underspecified and ambiguous requirements in the standards and gaps in the certification criteria. These discoveries have necessitated the collective efforts of numerous clinical subject matter experts and NIST to resolve, making the MU program a useful endeavor in perhaps unexpected ways. The findings have been recorded in clarification documents that supplement the HL7 V2 implementation guides. NIST, the ONC S&I Framework, the CDC, the AHPL, the ISDS, and the HL7 Conformance and Guidance for Implementation and Testing (CGIT) Working Group have begun efforts to establish and apply more concise rules for specifying conformance and best practices for writing HL7 V2 implementation guides. The result of these efforts will improve the HL7 V2 referenced standards for future MU editions.

In summary, meaningful use of EHRs is a key element in improving both quality and cost of healthcare. Two stages of the CMS MU and ONC HIT Certification Programs have been initiated, each stage representing incremental progress in the improvement of EHR systems' interoperability and capabilities based on the named standards in the ONC certification criteria. NIST develops the HL7 V2 conformance test tools in accordance with implementation guide requirements and vocabulary standards mandated by the ONC. Knowing that unambiguous, "testable" requirements are critical to development of robust certification testing tools, NIST as a neutral participant devotes time and resources to the collaborative process of creating the HL7 V2 implementation guides, reconciling the ballot comments for the draft versions, and determining content for the various clarification supplements. The ONC-ATLs use the NIST test tools to perform automated and semi-automated validation in a consistent manner for certification of EHRs based on requirements included in the standards. It cannot be over emphasized that the effectiveness of a certification program is dependent upon a combination of the quality of the underlying standards and the thoroughness of the test tools based on those standards.

Certification of EHR technologies is a critical step in achieving interoperability for exchanging healthcare information, as it provides a foundation that can be built upon. Much progress has been made and significant knowledge has been gained in the first two MU stages. MU Stage 3 promises to build further upon this foundation.